

# Mazda 323

1988  
Workshop Manual

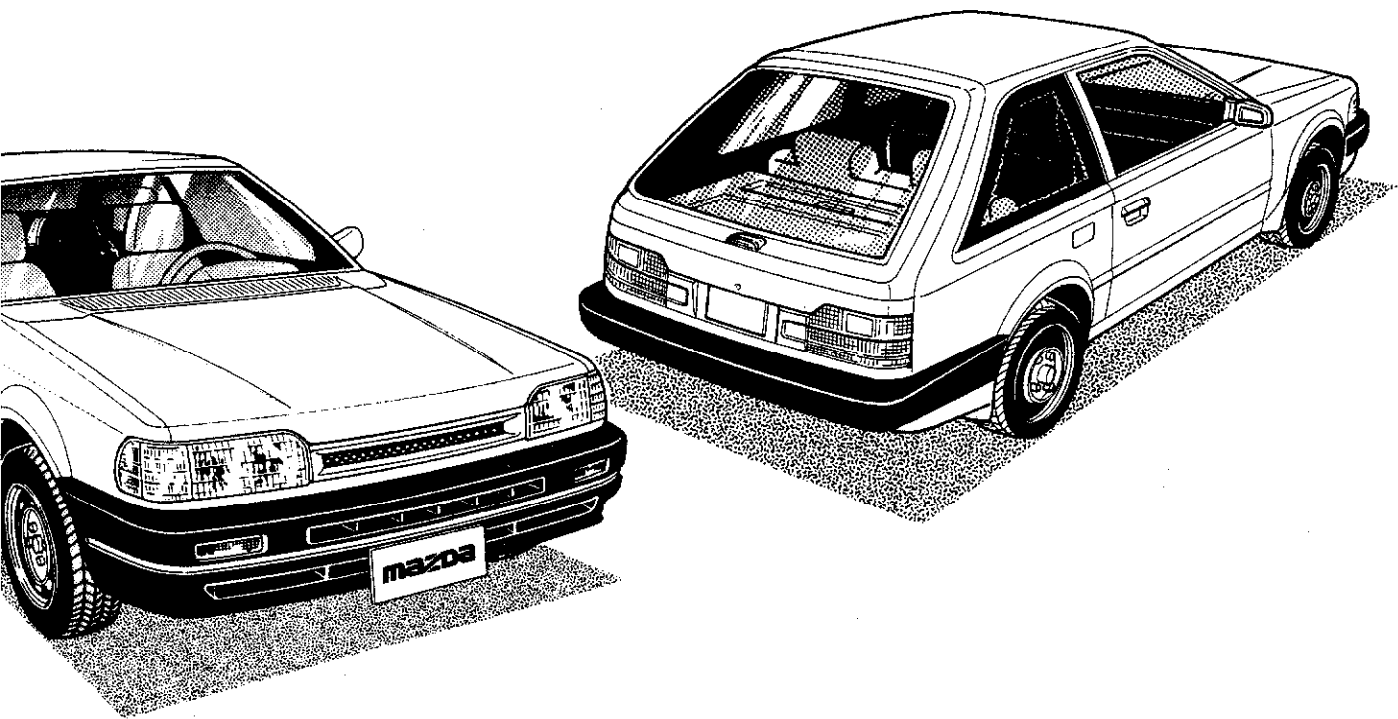

**mazda**

# 1988 Mazda 323 Workshop Manual

## FOREWORD

This workshop manual is intended for use by service technicians of authorized Mazda dealers to help them service Mazda vehicles. This manual can be also useful for Mazda owners in diagnosing certain problems and performing some repair and maintenance on Mazda vehicles.

For proper repair and maintenance, it is important to be thoroughly familiarized with this manual. It is recommended that this manual always be kept in a handy place for quick and easy reference.

All the contents of this manual, including photographs, drawings, and specifications, are the latest available at the time of printing. As modifications affecting repair or maintenance occur, relevant information supplementary to this volume will be made available at Mazda dealers. This manual should be kept up-to-date.

Mazda Motor Corporation reserves the right to alter the specifications and contents of this manual without obligation or advance notice.

All rights reserved. No part of this book may be reproduced or utilized in any form or by any means, electronic or mechanical, including photocopying, recording, or by any information storage and retrieval system, without permission in writing.

**Mazda Motor Corporation  
HIROSHIMA JAPAN**

## CONTENTS

Title		Section
General Information		G
Pre-Delivery Inspection and Scheduled Maintenance		0
Engine	B6 EGI	1A
	B6 DOHC	1B
Lubrication System	B6 EGI	2A
	B6 DOHC	2B
Cooling System	B6 EGI	3A
	B6 DOHC	3B
Fuel and Emission Control System	EGI	4A
	EGI Turbo	4B
Engine Electrical System		5
Clutch		6
Transaxle	Manual	7A
	Automatic	7B
	Manual 4WD	7C
Propeller Shaft		8
Front and Rear Axle		9
Steering System		10
Braking System		11
Wheels and Tires		12
Suspension		13
Body		14
Body Electrical System		15
Technical Data		30
Special Tools		40
Wiring Diagram		50

© 1987 Mazda Motor Corporation  
PRINTED IN JAPAN, MAY, '87 ©  
1165-10-87E



# GENERAL INFORMATION

IMPORTANT INFORMATION .....	G— 2
FUNDAMENTAL PROCEDURES.....	G— 2
JACK AND SAFETY STAND (RIGID RACK) POSITIONS .....	G— 6
VEHICLE LIFT (2-SUPPORT TYPE) POSITIONS .....	G— 6
TOWING .....	G— 7
MAINTENANCE NOTES (4WD MODEL) .....	G— 8
CHASSIS NUMBER LOCATION .....	G— 8
ENGINE MODEL AND NUMBER LOCATION .....	G— 8
ABBREVIATIONS .....	G— 9
UNITS.....	G— 9

83U0GX-001

## IMPORTANT INFORMATION

### BASIC ASSUMPTIONS

This workshop manual assumes that you have and know how to properly use certain special tools which are necessary for the safe and efficient performance of service operations on Mazda vehicles. The manual also assumes that you are generally familiar with automobile systems and basic service and repair procedures. You should not attempt to use this manual unless these assumptions are correct and you understand the consequences described below.

### SAFETY RISK

This manual contains certain notes, warnings, etc., which you should carefully read and follow in order to eliminate the risk of personal injury to yourself or others and the risk of improper service which may damage the vehicle or render it unsafe. The fact that there are not such notes, etc., with respect to any specific service method does not mean that there is no possibility that personal safety or vehicle safety will be jeopardized by the use of incorrect methods or tools.

### POSSIBLE LOSS OF WARRANTY

The manufacturer's warranty on Mazda vehicles and engines can be voided if improper service or repairs are performed by persons other than an authorized Mazda dealer.

## FUNDAMENTAL PROCEDURES

As you read through the procedure, you will come across NOTES, CAUTIONS, and WARNINGS. Each one is there for a specific purpose. **NOTES** give you **added information** that will help you to complete a particular procedure. **CAUTIONS** are given to prevent you from making an error that could **damage the vehicle**. **WARNINGS** remind you to be especially careful in those areas where carelessness can cause **personal injury**. The following list contains some general WARNINGS that you should follow when you work on a vehicle.

### PROTECTION OF THE VEHICLE

Always be sure to cover fenders, seats, and floor areas before starting work.

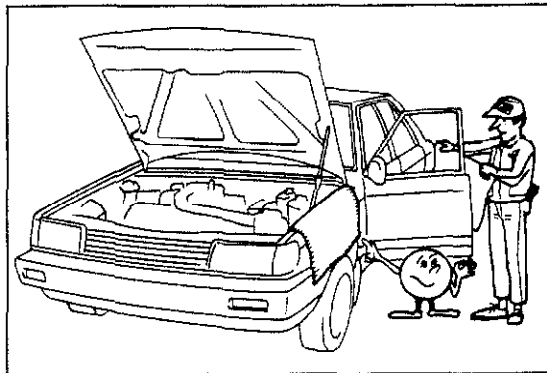

47U0GX-002

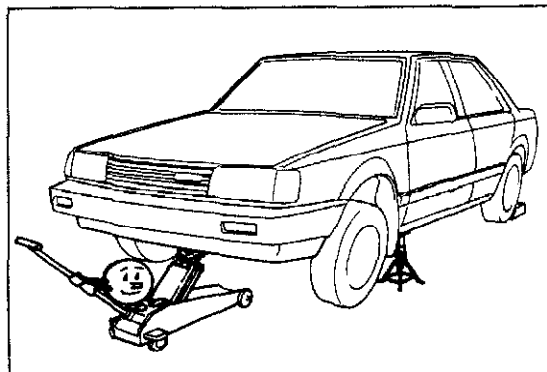

47U0GX-003

### A WORD ABOUT SAFETY

The following precautions must be followed when jacking up the vehicle.

1. Block wheels.
2. Use only specified jacking positions.
3. Support vehicle with safety stands (rigid racks).

Start the engine only after making certain the engine compartment is clear of tools and people.

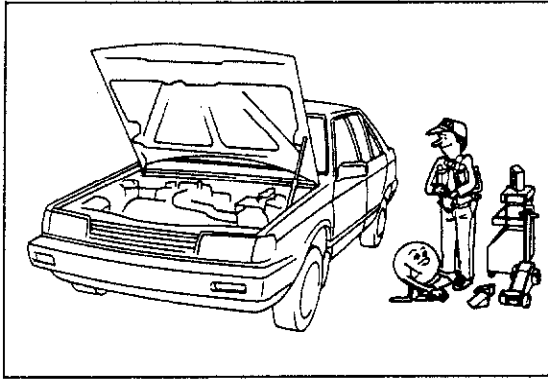

47U0GX-004

**PREPARATION OF TOOLS AND MEASURING EQUIPMENT**

Be sure that all necessary tools and measuring equipment are available before starting work activity.

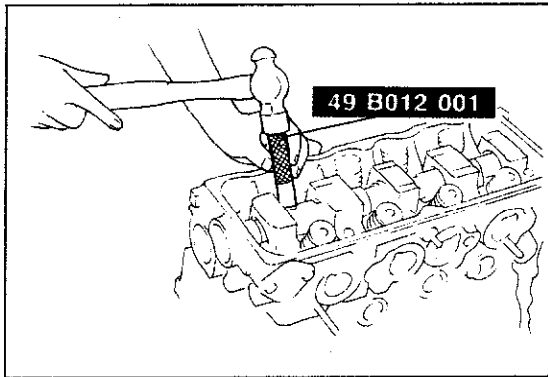

47G0GX-005

**SPECIAL TOOLS**

Use special tools when they are required.

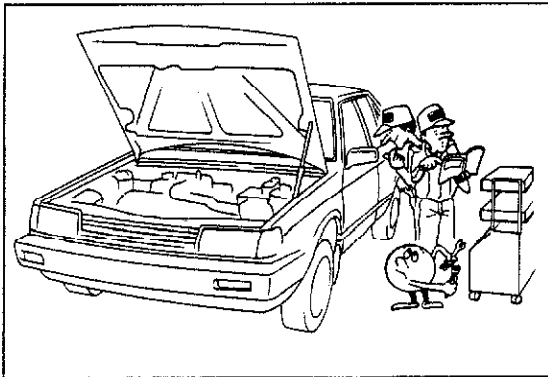

47G0GX-006

**REMOVAL OF PARTS**

While correcting a problem, try also to determine the cause. Begin work only after first learning which parts and subassemblies must be removed and disassembled for replacement or repair.

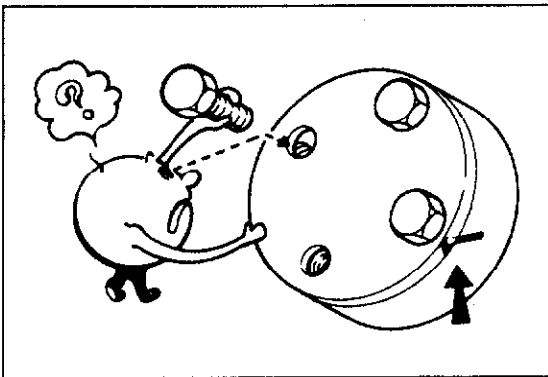

47G0GX-007

**DISASSEMBLY**

If the disassembly procedure is complex, requiring many parts to be disassembled, all parts should be disassembled in a way that will not affect their performance or external appearance and can be identified so that reassembly can be performed efficiently.

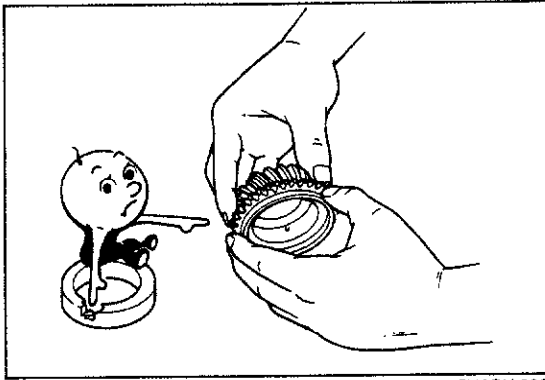

47U0GX-008

## DISASSEMBLY

### 1. Inspection of parts

Each part when removed should be carefully inspected for malfunctioning, deformation, damage or other problems.

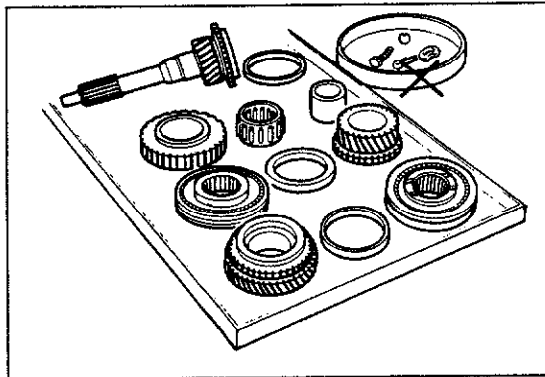

47U0GX-009

### 2. Arrangement of parts

All disassembled parts should be carefully arranged for reassembly.

Be sure to separate or otherwise identify the parts to be replaced from those that will be reused.

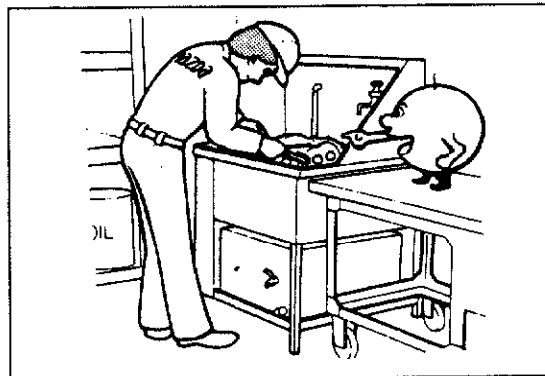

47U0GX-010

### 3. Cleaning parts for reuse

All parts to be reused should be carefully and thoroughly cleaned by the appropriate method.

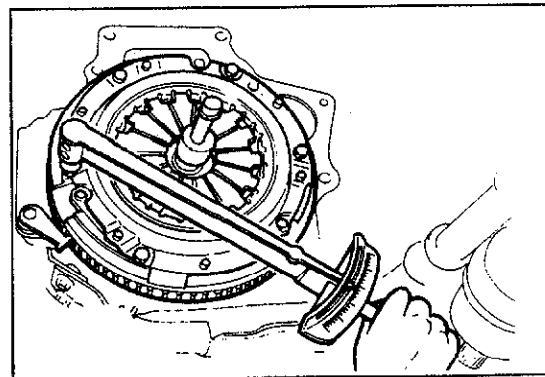

47U0GX-011

## REASSEMBLY

Standard values, such as torques and certain adjustments, must be strictly observed in the reassembly of all parts.

If removed, these parts should be replaced with new ones.

1. Oil seals
2. Gaskets
3. O-rings
4. Lock washers
5. Cotter pins (split pins)
6. Nylon nuts

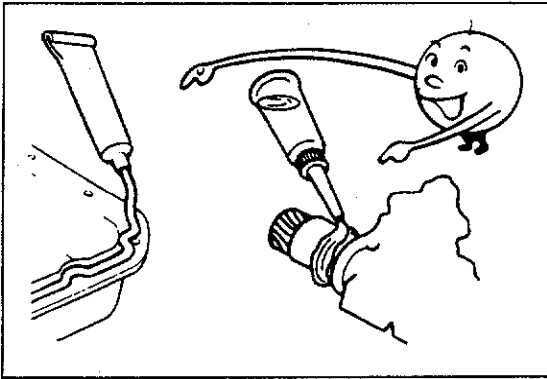

47U0GX-012

- Depending on where they are;
1. Sealant should be applied to gaskets
  2. Oil should be applied to moving components of parts
  3. Specified oil or grease should be applied at the prescribed locations (oil seals, etc.) before assembly.

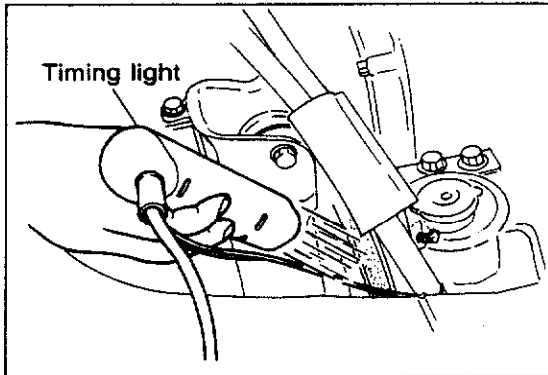

47U0GX-013

**ADJUSTMENTS**

Use gauges and testers to make adjustments to standard values.

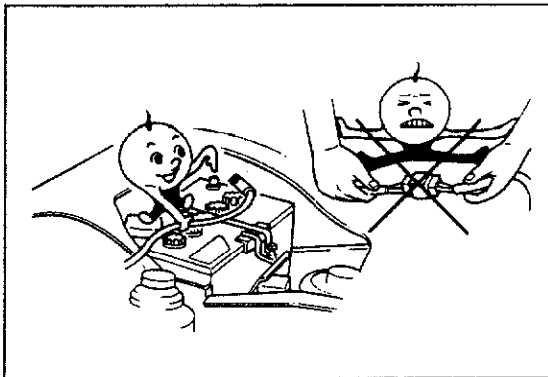

47U0GX-014

**ELECTRICAL SYSTEM**

Be sure to disconnect the battery cable from the negative (-) terminal of the battery.  
 Never pull on the wiring when disconnecting connectors.  
 Locking connectors must be heard to click for the connector to be secure.  
 Handle sensors and relays carefully. Be careful not to drop them or hit them against other parts.

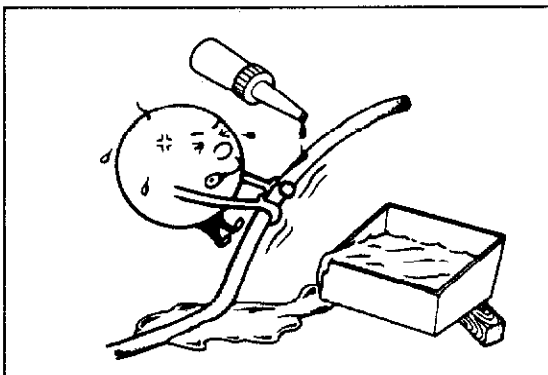

47U0GX-015

**RUBBER PARTS AND TUBING**

Always prevent gasoline or oil from touching rubber parts or tubing.

## JACK AND SAFETY STAND (RIGID RACK) POSITIONS

### FRONT

#### Jack position:

At the front of the engine mount member

#### Safety stand positions:

On both side sills (front)

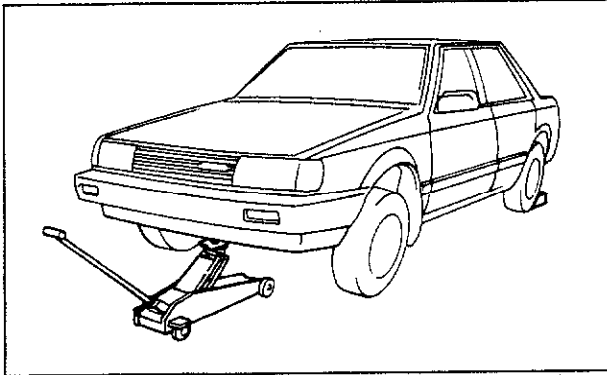

63U0GX-001

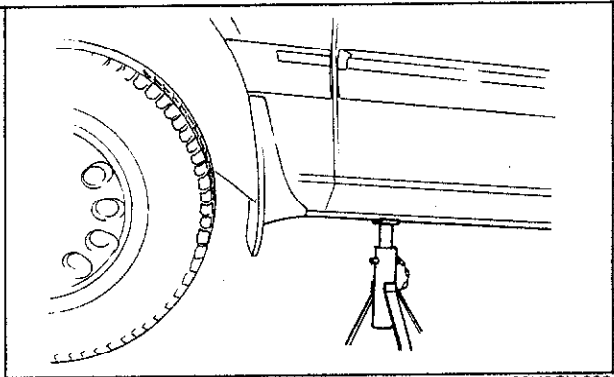

63U0GX-002

### REAR

#### Jack position:

At the center of the rear crossmember (2WD)

At the rear differential (4WD)

#### Safety stand positions:

On both side sills (rear)

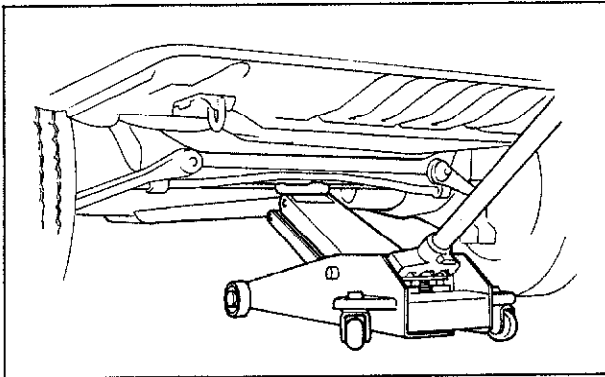

63U0GX-003

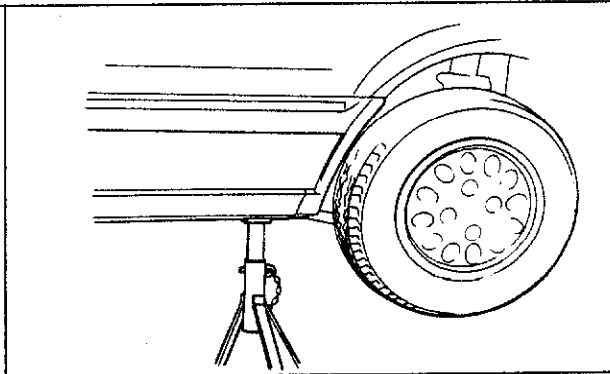

63U0GX-004

## VEHICLE LIFT (2-SUPPORT TYPE) POSITIONS

### Front

On both side sills

### REAR

On both side sills

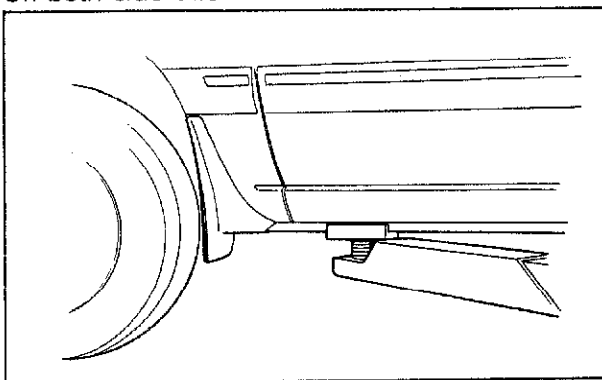

63U0GX-005

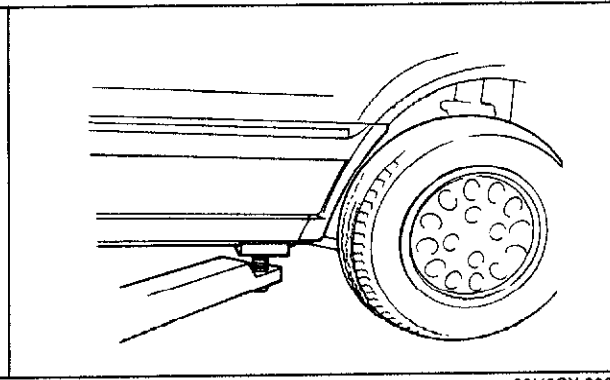

63U0GX-006

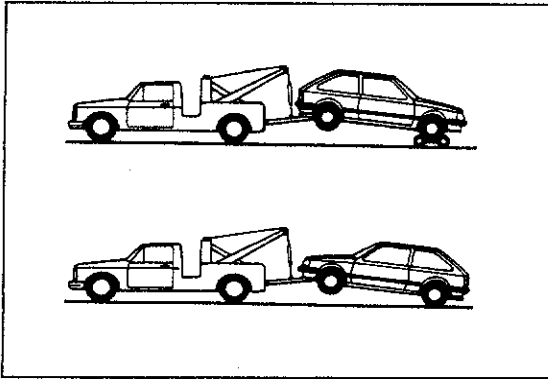

5BU0GX-003

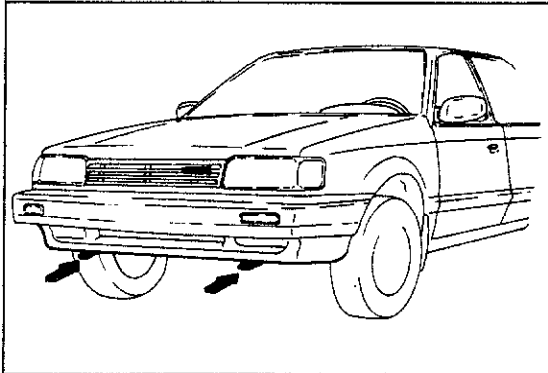

83U0GX-002

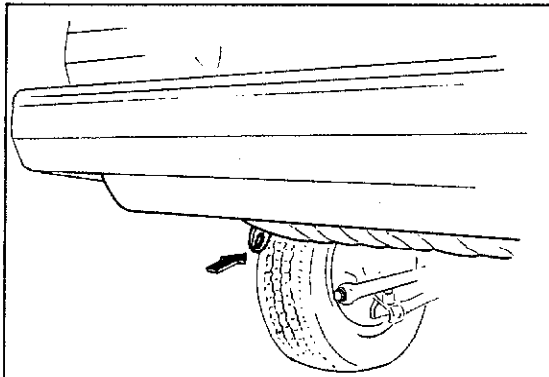

63U0GX-008

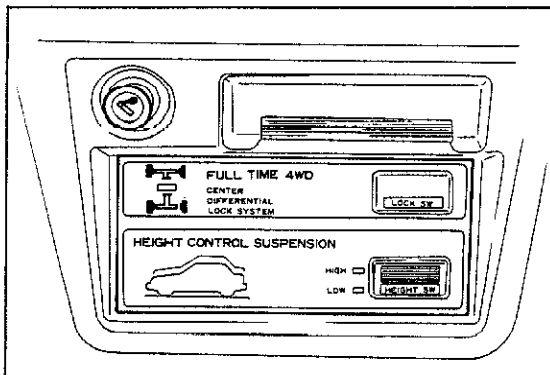

83U0GX-003

## TOWING

Proper towing equipment is necessary to prevent damage to the vehicle during any towing operation. Laws and regulations applicable to vehicles in tow must always be observed.

Release the parking brake, place the shift lever in neutral, and set the ignition key in the "ACC" position. As a rule, towed vehicles should be pulled with the drive wheels off the ground.

If excessive vehicle damage or other conditions prevent towing a vehicle with its drive wheels up, use wheel dollies. With all four wheels on the ground, the vehicle may be towed only forward. In this case, it cannot be towed at a speed exceeding 56 km/h (35 mph) for more than 80 km (50 miles) without danger of damaging the transaxle.

If the towing speed will exceed 56 km/h (35 mph), or if the towing distance will exceed 80 km (50 miles), use either of these two methods:

1. Place the front wheels on dollies.
2. Tow with the front wheels raised.

## CAUTIONS

- a) The power assistance for the brakes and steering will be in-operable while the engine is off.
- b) When either towing hooks or chains are used, always pull the cable or chain straight away from the hook and do not apply any sideways force to it. To further help prevent damage, do not take up slack too quickly in the cable or chain.
- c) The rear towing hook should be used only in an emergency situation, (e.g., to pull the vehicle from a ditch, a snowbank, or mud).

### d) (4WD model)

The center differential must never be in "Lock".

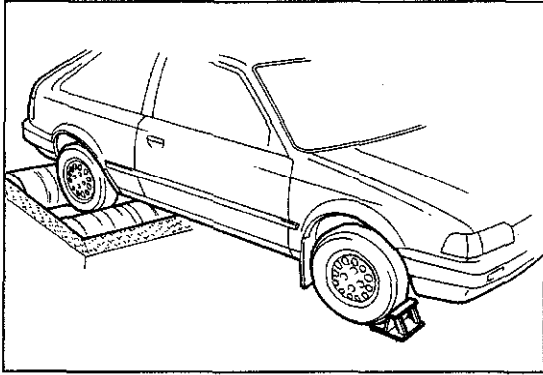

83U0GX-004

## MAINTENANCE NOTES (4WD MODEL)

If a speedometer tester or brake tester is used, **unlock the center differential**, and also note the followings.

### Speedometer Tester

- Place the rear wheels on the rollers
- Be sure to block the front wheels
- Shift to 2nd gear, carefully engage the clutch at low engine rpm, and increase engine speed gradually
- After completing the test, do not brake suddenly.

### Brake Tester

- Place the wheels to be measured on the rollers.
- Shift to neutral

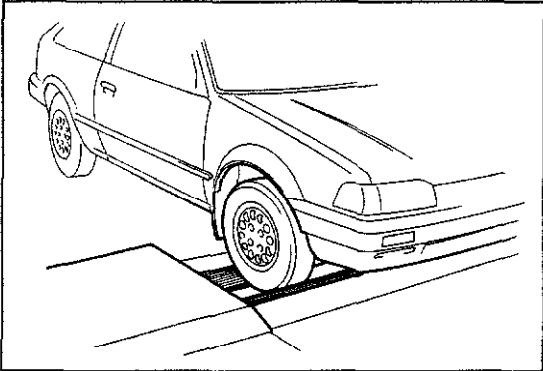

83U0GX-005

## CHASSIS NUMBER LOCATION

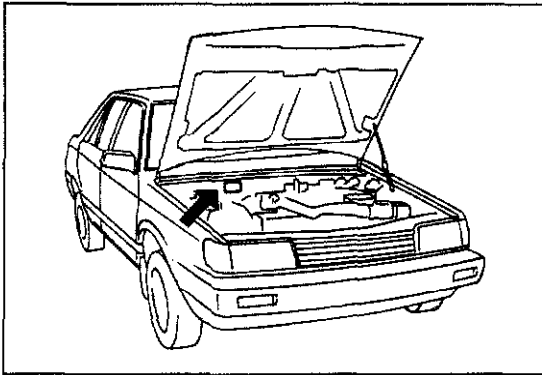

58U0GX-004

## ENGINE MODEL AND NUMBER LOCATION

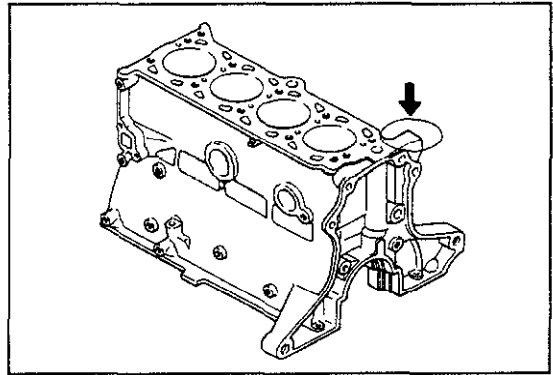



**ABBREVIATIONS**

AAS.....	Air adjust screw
AAV.....	Anti-afterburn valve
ABDC.....	After bottom dead center
ACC.....	Accessories
A/C.....	Air conditioner
ACV.....	Air control valve
ASA.....	Adjustable shock absorber
ASS"Y.....	Assembly
ATDC.....	After top dead center
ATF.....	Automatic transmission fluid
ATX.....	Automatic transaxle
BAC.....	Bypass air control
BBDC.....	Before bottom dead center
BTDC.....	Before top dead center
CPU.....	Central processing unit
CSD.....	Cold start device
DOHC.....	Double overhead camshaft
EGI.....	Electrical gasoline injection
EGR.....	Exhaust gas recirculation
E/L.....	Electrical load
ELR.....	Emergency locking retractor
EX.....	Exhaust
Fig.....	Figure
IC.....	Integrated circuit
IG/IGN.....	Ignition
IN.....	Intake
INT.....	Intermittent
ISC.....	Idle speed control
JB.....	Joint Box
LH.....	Left hand
M.....	Motor
MAS.....	Mixture adjust screw
MIL.....	Malfunction indicator light
M/T.....	Manual transmission
MTX.....	Manual transaxle
O/D.....	Overdrive
OFF.....	Switch off
ON.....	Switch on
PBV.....	Proportioning by-pass valve
PCV Valve.....	Positive crankcase ventilation valve
PS.....	Power steering
PW.....	Power window
QSS.....	Quick start system
RH.....	Right hand
Sec.....	Second(s)
SST.....	Special service tool
ST.....	Start
SW.....	Switch
TDC.....	Top dead center
4WD.....	4-wheel drive

**UNITS**

N-m (m-kg, ft-lb).....	Torque
rpm.....	Revolutions per minute
A.....	Ampere(s)
V.....	Volt(s)
$\Omega$ .....	Ohm(s)(resistance)
KPa (kg/cm <sup>2</sup> , psi)...	Pressure (usually positive)
mm Hg (in Hg).....	Pressure (usually negative)
W.....	Watt

83U0GX-009



# **PRE-DELIVERY INSPECTION AND SCHEDULED MAINTENANCE SERVICES**

**PRE-DELIVERY INSPECTION..... 0— 2**  
**SCHEDULED MAINTENANCE SERVICES .... 0— 3**

63U00X-025

## PRE-DELIVERY INSPECTION TABLE

### EXTERIOR

**INSPECT** and **ADJUST**, if necessary, the following items to specification:

- Glass, exterior bright metal and paint for damage
- Wheel lug bolts/nuts 88—118 N·m (9—12 m·kg, 65—87 ft·lb)
- Tire pressures Front 196 N (2.0 kg/cm<sup>2</sup>, 28 psi)  
Rear 177 N (1.8 kg/cm<sup>2</sup>, 26 psi)
- All weatherstrips for damage or detachment
- Operation of hood release and lock
- Operation of trunk lid, back door and fuel lid opener (if equipped)
- Door operation and alignment
- Headlight aim

**INSTALL** following parts:

- Wheel caps or rings (if equipped)
- Outside mirror (s)

### UNDER HOOD-ENGINE OFF

**INSPECT** and **ADJUST**, if necessary, the following items to specification:

- Fuel, coolant and hydraulic lines, fittings, connections and components for leaks
- Engine oil level
- Power steering fluid level (if equipped)
- Brake master cylinder fluid level
- Clutch master cylinder fluid levels (if equipped)
- Windshield washer reservoir fluid level
- Radiator coolant level and specific gravity

Protection	Specific gravity at 20°C (68°F)
Above -4°C (25°F)	1.028
Above -16°C (3°F)	1.054
Above -26°C (-15°F)	1.066
Above -40°C (-40°F)	1.078

- Tightness of battery terminals
- Manual transaxle oil level
- Drive belt(s) tension...Refer to section 1
- Accelerator cable for free movement

**CLEAN** spark plugs

### INTERIOR

**INSTALL** the following parts:

- Rubber stopper for inside rear view mirror (if equipped)
- Fuse for accessories

**CHECK** the operation of the following items:

- Seat controls (sliding and reclining) and head rest
- Seat belts and warning system
- Ignition switch and steering lock
- Power window (if equipped)
- Inhibitor switch (ATX only)
- All lights including warning and indicator lights
- Ignition key reminder buzzer (if equipped)
- Horn, wipers and washers (front and rear, if equipped)
- Radio and antenna (if equipped)
- Center differential lock switch
- Cigarette lighter and clock (if equipped)
- Remote control outside mirror (S) (if equipped)

- Heater, defroster and air conditioner at various mode selections (if equipped)
- Sunroof (if equipped)

**ADJUST** antenna trimmer on radio (if equipped)

**CHECK** the following items:

- Presence of spare fuse
- Upholstery and interior finish

**CHECK** and **ADJUST**, if necessary, the following items:

- Operation and fit of windows
- Pedal height and free play of brake and clutch pedal

		Pedal height mm (in)	Free play mm (in)
Clutch pedal	2WD	214.5—219.5 (8.44—8.64)	9—15 (0.35—0.59)
	4WD	229—234 (9.02—9.22)	0.6—3.0 (0.02—0.12)
Brake pedal		214—219 (8.43—8.63)	4—7 (0.16—0.28)

- Parking brake  
5—7 notches/98 N (10 kg, 22 lb)

### UNDER HOOD-ENGINE RUNNING AT OPERATING TEMPERATURE

**CHECK** following items:

- Operation of throttle sensor
- Automatic transaxle fluid level
- Initial ignition timing...BTDC 2 ± 1° Non turbo  
BTDC 12° ± 1° Turbo

### ON HOIST

**CHECK** the following items:

- Underside fuel, coolant and hydraulic lines, fittings, connections and components for leaks
- Tires for cuts or bruises
- Steering linkage, suspension, exhaust system and all underside hardware for looseness or damage

**REMOVE** protective cover from brake disc (if equipped)

### ROAD TEST

**CHECK** the following items:

- Brake operation
- Clutch operation (MTX only)
- Steering control
- Operation of meters and gauge
- Squeaks, rattles or unusual noise
- Engine general performance
- Emergency locking retractors
- Cruise control system (if equipped)

### AFTER ROAD TEST

**REMOVE** seat and floor mat protective covers

**CHECK** for necessary owner information materials, tools and spare tire in vehicle

# SCHEDULED MAINTENANCE SERVICES

Follow the Schedule 1 (Normal Driving Condition) if you mainly operate your vehicle where none of the following conditions apply. Contrary follow the Schedule 2 (Unique Driving Condition) if one or more them apply;

- Repeated short distance driving.
- Driving in dusty condition.
- Driving in extended use of brakes.
- Driving in areas using road salt or other corrosive materials.
- Driving on rough and/or muddy road.
- Extended periods of idling and/or low speed operation.
- Driving for a prolonged period in cold temperature and/or extremely humid climates.

## Schedule 1 (Normal Driving Condition)

MAINTENANCE INTERVALS		Number of months or miles (kilometers), whichever comes first								Service data and inspection points	Page													
		Months	7.5	15	22.5	30	37.5	45	52.5			60												
		x 1,000 miles	7.5	15	22.5	30	37.5	45	52.5			60												
MAINTENANCE OPERATION		x 1,000 km	12	24	36	48	60	72	84	96														
Drive belts					I					I	<ul style="list-style-type: none"> <li>• Check for damage</li> <li>• Tension</li> </ul>	1A—6 1B—6												
Engine oil	Non turbo	R	R	R	R	R	R	R	R	R	<ul style="list-style-type: none"> <li>• Oil pan capacity: B6 EGI engine 3.0 liters (3.2 US qt, 2.5 Imp qt)</li> <li>• B6 DOHC engine 3.2 liters (3.4 US qt, 2.8 Imp qt)</li> </ul>	1A—5 1B—5												
	Turbo	Replace every 5,000 miles (8,000 km) or 5 months																						
Oil filter	Non turbo	R	R	R	R	R	R	R	R	R	<ul style="list-style-type: none"> <li>• Oil filter capacity: 0.3 liter (0.32 US qt, 0.26 Imp qt)</li> </ul>	2A—4 2B—4												
	Turbo	Replace every 5,000 miles (8,000 km) or 5 months																						
Engine timing belt *1		Replace the timing belt every 60,000 miles (96,000 km)								—	1A—11 1B—11													
Air cleaner element					R					R	—	1A—5 1B—5												
Spark plugs					R					R	<ul style="list-style-type: none"> <li>• Plug gap: 1.0—1.1 mm (0.039—0.043 in)</li> <li>• Recommended spark plugs</li> </ul> <table border="1"> <tr> <td></td> <td>B6 EGI</td> <td>B6 DOHC</td> </tr> <tr> <td>NGK</td> <td>BPR5ES-11</td> <td>BCPR6E-11</td> </tr> <tr> <td>NIPPON DENSO</td> <td>W16EXR-U11</td> <td>Q20PR-U11</td> </tr> <tr> <td>CHAMPION</td> <td>RN11YC4</td> <td>—</td> </tr> </table>		B6 EGI	B6 DOHC	NGK	BPR5ES-11	BCPR6E-11	NIPPON DENSO	W16EXR-U11	Q20PR-U11	CHAMPION	RN11YC4	—	1A—8 1B—8 5—29
	B6 EGI	B6 DOHC																						
NGK	BPR5ES-11	BCPR6E-11																						
NIPPON DENSO	W16EXR-U11	Q20PR-U11																						
CHAMPION	RN11YC4	—																						
Cooling system			I		I		I			I	<ul style="list-style-type: none"> <li>• Hoses for cracks or wear</li> <li>• Coolant level</li> </ul>	3A—4 3B—4												
Engine coolant					R					R	<ul style="list-style-type: none"> <li>• Coolant capacity: B6 EGI: 5.0 liters (5.3 US qt, 4.4 Imp qt)..MTX 6.0 liters (6.3 US qt, 5.3 Imp qt)..ATX B6 DOHC 6.0 liters (6.3 US qt, 5.3 Imp qt)</li> </ul>	3A—4 3B—4												
Fuel filter										R	—	1A—45 1B—51												

## Schedule 1 (Normal Driving Condition)

MAINTENANCE OPERATION	MAINTENANCE INTERVALS	Number of months or miles (kilometers), whichever comes first								Service data and inspection points	Page	
		Months	7.5	15	22.5	30	37.5	45	52.5			60
		x 1,000 miles	7.5	15	22.5	30	37.5	45	52.5			60
	x 1,000 km	12	24	36	48	60	72	84	96			
Idle speed					A <sup>*2</sup>				A <sup>*2</sup>	• 850 ± 50 rpm...ATX P range ...MTX N range	—	
Fuel lines					1 <sup>*3</sup>				1 <sup>*3</sup>	• Fittings, connections and components for leaks	4A—33 4B—36	
Brake line hoses and connection			I		I		I		I	• Proper attachment and connections	—	
Clutch pedal			I		I		I		I	• Operation • Pedal height: 214.5 ± <sup>5</sup> <sub>0</sub> mm (8.44 ± <sup>0.2</sup> <sub>0</sub> in) 2WD model 229 ± <sup>5</sup> <sub>0</sub> mm (9.02 ± <sup>0.2</sup> <sub>0</sub> in) 4WD model • Free play: 9—15 mm (0.35—0.59 in) 2WD model 0.6—3.0 mm (0.02—0.12 in) 4WD model	6—5 6—9	
Drum brake					I				I	• Wheel cylinder operation and leakage • Lining for wear or damage • Thickness of lining minimum...1.0 mm (0.039 in) • Drum inner diameter maximum...201 mm (7.91 in)	11—38	
Disc brake			I		I		I		I	• Caliper operation • Thickness of disc plate minimum...Front 16 mm (0.63 in) Rear 9 mm (0.35 in) • Thickness of pad minimum...Front 2.0 mm (0.079 in) Rear 1.0 mm (0.039 in)	11—27	
Steering operation and linkage					I				I	• Operation and looseness • Fluid leakage or oozing • Free play...0—30 mm (0—1.18 in)	10—7 10—9	
Front suspension ball joint					I				I	• Damage, looseness and grease leakage	—	
Driveshaft dust boots					I				I	• Cracking and damage	9—7	
Bolts and nuts on chassis and body			T				T			• Retighten all loose nuts and bolts	—	
Exhaust system heat shield					I				I	• Insulation clearance	4A—71 4B—86	
Transfer oil (4WD model)		R			R				R	• Oil capacity...0.5 liter (0.53 US qt, 0.44 imp qt)	7C—7	
Rear axle oil (4WD model)									R	• Oil capacity...0.65 liter (0.69 US qt, 0.57 imp qt)	9—42	

323 Revised 10/87

83U00X-003

**Note**

**I** ...Inspect, and if necessary correct, clean or replace

**A**...Adjust

**R**...Replace or change

**T**...Tighten

**L**...Lubricate

After 60 months or 60,000 miles (96,000 km), continue to follow the described maintenance items and intervals periodically.

As for \* marked items in this maintenance chart, please pay attention to the following points.

- \*1 Replacement of timing belt is required at every 60,000 miles (96,000 km). Failure to replace the timing belt may result in damage to the engine.
- \*2 This maintenance operation is required for all states except California. However we do recommended that this operation be performed on California vehicles as well.
- \*3 This maintenance operation is recommended by Mazda. However, this maintenance is not necessary for emission warranty coverage or manufacturer recall liability.

### Schedule 2 (Unique Driving Condition)

MAINTENANCE INTERVALS		Number of months or miles (kilometers), whichever comes first												Service data and inspection points	Page													
		Months	5	10	15	20	25	30	35	40	45	50	55			60												
		x 1,000 miles	5	10	15	20	25	30	35	40	45	50	55			60												
MAINTENANCE OPERATION		x 1,000 km	8	16	24	32	40	48	56	64	72	80	88	96														
Drive belt								I						I	<ul style="list-style-type: none"> <li>• Check for damage</li> <li>• Tension</li> </ul>	1A-6 1B-6												
Engine oil	Non turbo	R	R	R	R	R	R	R	R	R	R	R	R	R	<ul style="list-style-type: none"> <li>• Oil pan capacity: B6 EGI engine...3.0 liters (3.2 US qt, 2.6 Imp qt)</li> <li>B6 DOHC engine...3.2 liters (3.4 US qt, 2.8 Imp qt)</li> </ul>	1A-5 1B-5												
	Turbo	Replace every 3,000 miles (5,000 km) or 3 months																										
Oil filter	Non turbo	R	R	R	R	R	R	R	R	R	R	R	R	R	<ul style="list-style-type: none"> <li>• Oil filter capacity: 0.3 liter (0.32 US qt, 0.26 Imp qt)</li> </ul>	2A-4 2B-4												
	Turbo	Replace every 3,000 miles (5,000 km) or 3 months																										
Engine timing belt *1		Replace the timing belt every 60,000 miles (96,000 km)												—	1A-11 1B-11													
Air cleaner element				I*2				R				I*2		R		1A-5 1B-5												
Spark plugs								R						R	<ul style="list-style-type: none"> <li>• Plug gap: 1.0—1.1 mm (0.039—0.043 in)</li> <li>• Recommended spark plugs</li> </ul> <table border="1"> <tr> <td></td> <td>B6 EGI</td> <td>B6 DOHC</td> </tr> <tr> <td>NGK</td> <td>BPR5ES-11</td> <td>BCPR6E-11</td> </tr> <tr> <td>NIPPON DENSO</td> <td>W16EXR-U11</td> <td>Q20PR-U11</td> </tr> <tr> <td>CHAMPION</td> <td>RN11YC4</td> <td></td> </tr> </table>		B6 EGI	B6 DOHC	NGK	BPR5ES-11	BCPR6E-11	NIPPON DENSO	W16EXR-U11	Q20PR-U11	CHAMPION	RN11YC4		1A-8 1B-8 5-29
	B6 EGI	B6 DOHC																										
NGK	BPR5ES-11	BCPR6E-11																										
NIPPON DENSO	W16EXR-U11	Q20PR-U11																										
CHAMPION	RN11YC4																											
Cooling system				I				I						I	<ul style="list-style-type: none"> <li>• Hoses for cracks or wear</li> <li>• Coolant level</li> </ul>	3A-4 3B-4												
Engine coolant								R						R	<ul style="list-style-type: none"> <li>• Coolant capacity</li> <li>B6 EGI: 5.0 liters (5.3 US qt, 4.4 Imp qt)...ATX 6.0 liters (6.3 US qt, 5.3 Imp qt)...ATX</li> <li>B6 DOHC 6.0 liters (6.3 US qt, 5.3 Imp qt)</li> </ul>	3A-4 3B-4												
Idle speed								A*2						A*2	<ul style="list-style-type: none"> <li>• 850 ± 50 rpm...ATX P range</li> <li>...MTX N range</li> </ul>	—												
Fuel filter														R	—	1A-45 1B-45												
Fuel lines								I*3						I	<ul style="list-style-type: none"> <li>• Fittings connections and components for leaks</li> </ul>	4A-33 4B-36												
Brake line hoses and connection				I				I						I	<ul style="list-style-type: none"> <li>• Proper attachment and connections</li> </ul>	—												
Brake fluid								R						R	<ul style="list-style-type: none"> <li>• Brake fluid</li> <li>FMVSS116 DOT3 or DOT4 or SAEJ1703a</li> </ul>	11-11												

323 Revised 10/87

**Schedule 2 (Unique Driving Condition)**

MAINTENANCE INTERVALS MAINTENANCE OPERATION	Number of months or miles (kilometers), whichever comes first													Service data and inspection points	Page
	Months	5	10	15	20	25	30	35	40	45	50	55	60		
	x 1,000 miles	5	10	15	20	25	30	35	40	45	50	55	60		
x 1,000 km	8	16	24	32	40	48	56	64	72	80	88	96			
Clutch pedal				I			I			I			I	<ul style="list-style-type: none"> <li>• Operation</li> <li>• Pedal height: 214.5 <math>\pm</math>5 mm (8.44 <math>\pm</math>0.20 in) 2WD model 229 <math>\pm</math>5 mm (9.02 <math>\pm</math>0.20 in) 4WD model</li> <li>• Free play 9—15 mm (0.35—0.59 in) 2WD model 0.6—3.0 mm (0.02—0.12 in) 4WD model</li> </ul>	6—5 6—9
Drum brake							I						I	<ul style="list-style-type: none"> <li>• Wheel cylinder operation and leakage</li> <li>• Lining for wear or damage</li> <li>• Thickness of lining minimum 1.0 mm (0.039 in)</li> <li>• Drum inner diameter maximum 201 mm (7.91 in)</li> </ul>	11—29
Disc brake				I			I			I			I	<ul style="list-style-type: none"> <li>• Caliper operation</li> <li>• Thickness of pad minimum Front...2.0 mm (0.79 in) Rear...1.0 mm (0.039)</li> <li>• Thickness of disc plate minimum Front...16 mm (0.63 in) Rear...9 mm (0.35 in)</li> </ul>	11—27
Steering operation and linkage							I						I	<ul style="list-style-type: none"> <li>• Operation and looseness</li> <li>• Fluid leakage or oozing</li> <li>• Free play...0—30 mm (0—1.18 in)</li> </ul>	10—7 10—9
Front suspension ball joint							I						I	<ul style="list-style-type: none"> <li>• Damage looseness and grease leakage</li> </ul>	—
Front and rear wheel bearing													L	<ul style="list-style-type: none"> <li>• Lubricate with lithium grease (NLGI No. 2)</li> <li>• All friction surfaces</li> </ul>	9—28 9—33
Drive shaft dust boots							I						I	<ul style="list-style-type: none"> <li>• Cracking and damage</li> </ul>	9—7
Bolts and nuts on chassis and body				T			T			T			T	<ul style="list-style-type: none"> <li>• Retighten all loose nuts and bolts</li> </ul>	—
Exhaust system heat shield							I						I	<ul style="list-style-type: none"> <li>• Insulator clearance</li> </ul>	4A—71 4B—86
Transfer oil (4WD model)	R						R						R	<ul style="list-style-type: none"> <li>• Oil capacity...0.5 liter (0.53 US qt, 0.44 imp qt)</li> </ul>	7C—7
Rear axle oil (4WD) model)													R	<ul style="list-style-type: none"> <li>• Oil capacity...0.65 liter (0.69 US qt, 0.57 imp qt)</li> </ul>	9—42

323 Revised 10/87

0—7

83U00X-006



**Note**

**I** ...Inspect, and if necessary correct, clean or replace

**A**...Adjust

**R**...Replace or change

**T**...Tighten

**L**...Lubricate

After 60 months or 60,000 miles (96,000 km), continue to follow the described maintenance items and intervals periodically.

As for \* marked items in this maintenance chart, please pay attention to the following points.

- \*1 Replacement of the timing belt is required at every 60,000 miles (96,000 km). Failure to replace the timing belt may result in damage to the engine.
- \*2 This maintenance operation is required for all states except California. However we do recommend that this operation be performed on California vehicles as well.
- \*3 This maintenance operation is recommended by Mazda. However, this maintenance is not necessary for emission warranty coverage or manufacturer recall liability.

# ENGINE (B6 EGI)

<b>OUTLINE</b> .....	1A— 2
STRUCTURAL VIEW .....	1A— 2
SPECIFICATIONS .....	1A— 3
<b>TROUBLESHOOTING GUIDE</b> .....	1A— 3
<b>TUNE-UP PROCEDURE</b> .....	1A— 5
<b>ON-VEHICLE MAINTENANCE</b> .....	1A—11
TIMING BELT .....	1A—11
CYLINDER HEAD .....	1A—15
VALVE SEAL .....	1A—21
<b>REMOVAL AND INSTALLATION</b> .....	1A—25
<b>DISASSEMBLY</b> .....	1A—28
<b>INSPECTION AND REPAIR</b> .....	1A—37
<b>ASSEMBLY</b> .....	1A—51

83U01A-001

## OUTLINE

### STRUCTURAL VIEW

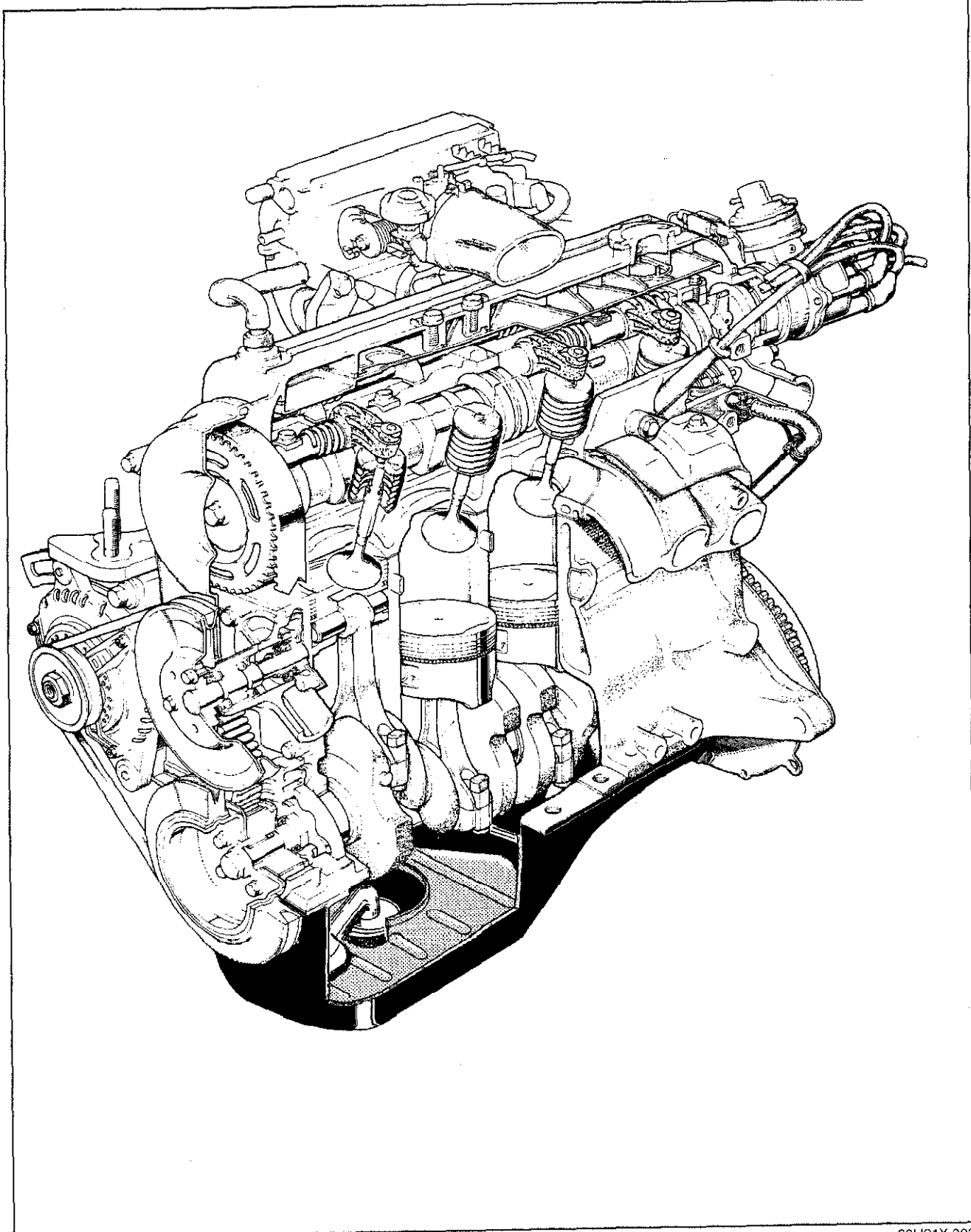

63U01X-002

## SPECIFICATIONS

Item		Engine model	B6
Type			Gasoline, 4-cycle
Cylinder arrangement and number			In line 4-cylinders
Combustion chamber			Multispherical
Valve system			OHC, belt-driven
Displacement		cc (cu in)	1,597 (97.4)
Bore and stroke		mm (in)	78 x 83.6 (3.07 x 3.29)
Compression ratio			9.3 : 1
Compression		kPa (kg/cm <sup>2</sup> , psi)—rpm	1,324 (13.5, 192) — 270
Valve timing	IN	Open BTDC	14°
		Close ABDC	50°
	EX	Open BBDC	52°
		Close ATDC	12°
Valve clearance	mm (in)	IN	0. Maintenance free
		EX	0. Maintenance free
Idle speed (MTX in neutral, ATX in "P" range)		rpm	850 ± 50
Ignition timing		BTDC	2° ± 1°
Firing order			1—3—4—2

83U01A-002

## TROUBLESHOOTING GUIDE

Problem	Possible Cause	Remedy	Page
<b>Difficult starting</b>	<b>Malfunction of engine-related components</b> Burned valve Worn piston, piston ring, or cylinder Failed cylinder head gasket	Replace Replace or repair Replace	1A—38 1A—46 1A—15
	<b>Malfunction of fuel system</b>	Refer to Section 4A	
	<b>Malfunction of electrical system</b>	Refer to Section 5	
<b>Poor idling</b>	<b>Malfunction of engine-related components</b> Malfunction of HLA Poor valve to valve seat contact Failed cylinder head gasket	Replace Repair or replace Replace	1A—61 1A—41
	<b>Malfunction of fuel system</b>	Refer to Section 4A	
<b>Excessive oil consumption</b>	<b>Oil working up</b> Worn piston ring groove or sticking piston ring Worn piston or cylinder	Replace Replace or repair	1A—46 1A—46
	<b>Oil working down</b> Worn valve seal Worn valve stem or guide	Replace Replace	1A—21 1A—38
	<b>Oil leakage</b>	Refer to Section 2A	

83U01A-003

# 1A TROUBLESHOOTING GUIDE

Problem	Possible Cause	Remedy	Page
<b>Insufficient power</b>	<b>Insufficient compression</b> Malfunction of HLA Compression leakage from valve seat Seized valve stem Weak or broken valve spring Failed cylinder head gasket Cracked or distorted cylinder head Sticking, damaged, or worn piston ring Cracked or worn piston	Replace Repair Replace Replace Replace Replace Replace Replace	1A—61 1A—41 1A—38 1A—41 1A—15 1A—37 1A—46 1A—46
	<b>Malfunction of fuel system</b>	Refer to Section 4A	
	<b>Others</b> Slipping clutch Dragging brakes Wrong size tires	Refer to Section 6 Refer to Section 11 Refer to Section 12	
<b>Abnormal combustion</b>	<b>Malfunction of engine-related components</b> Malfunction of HLA Sticking or burned valve Weak or broken valve spring Carbon accumulation in combustion chamber	Replace Replace Replace Eliminate carbon	1A—61 1A—38 1A—41 —
	<b>Malfunction of fuel system</b>	Refer to Section 4A	
<b>Engine noise</b>	<b>Crankshaft or bearing related parts</b> Excessive main bearing oil clearance Main bearing seized or heat-damaged Excessive crankshaft end play Excessive connecting rod bearing oil clearance Connecting rod bearing seized or heat-damaged	Replace or repair Replace Replace or repair Replace or repair Replace	1A—53 1A—53 1A—54 1A—55 1A—55
	<b>Piston related parts</b> Worn cylinder Worn piston or piston pin Seized piston Damaged piston ring Bent connecting rod	Replace or repair Replace Replace Replace Replace	1A—45 1A—47 1A—46 1A—46 1A—48
	<b>Valves or timing related parts</b> Malfunction of HLA * Broken valve spring Excessive valve guide clearance Malfunction of timing belt tensioner Insufficient lubrication of rocker arm	Replace Replace Replace Replace Replace	1A—61 1A—41 1A—38 1A—50 1A—43
	<b>Malfunction of cooling system</b>	Refer to Section 3A	
	<b>Malfunction of fuel system</b>	Refer to Section 4A	
	<b>Others</b> Malfunction of water pump bearing Improper drive-belt tension Malfunction of alternator bearing Exhaust gas leakage	Replace Adjust Replace Repair	— 1A—6 — 1A—37

\* Tapet noise may occur if the engine is not operated for an extended period of time. The noise should disappear after the engine has reached normal operating temperature.

83U01A-004

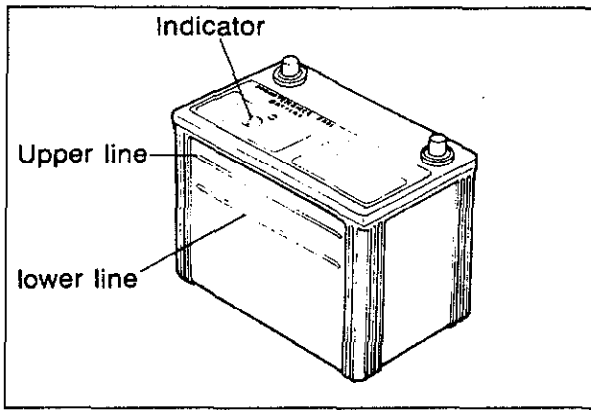

5BU01X-007

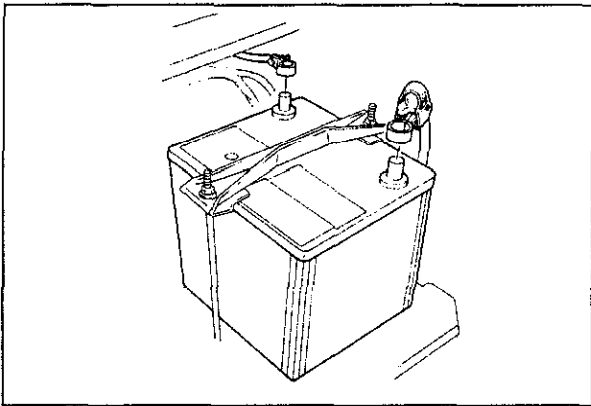

5BU01X-008

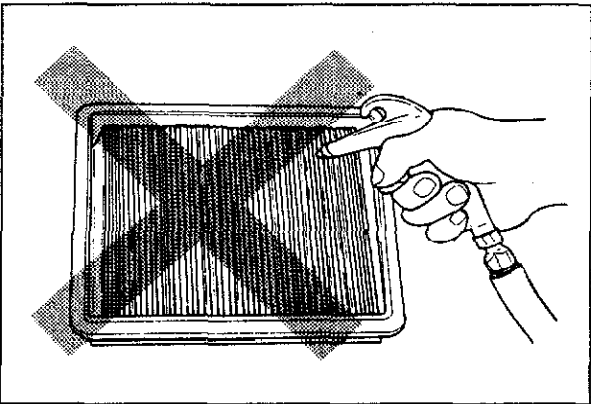

63G01D-306

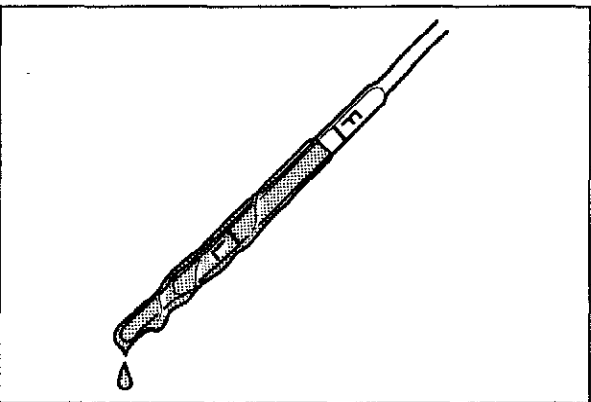

4BG01A-010

## TUNE-UP PROCEDURE

Tune the engine according to the procedures described below.

5BU01X-006

### Battery

1. Check the indicator sign on the top of the battery. If the indicator sign is blue, the battery is normal.
2. If the blue indicator sign is not visible, then the electrolyte level of the battery is low and/or the capacity is insufficient.
3. Add distilled water and/or recharge according to the procedures described in Section 5.
4. Check the tightness of the terminals to ensure good electrical connections. Clean the terminals and coat the terminals with grease.
5. Inspect for corroded or frayed battery cables.
6. Check the rubber protector on the positive terminal for proper coverage.

### Air Cleaner Element

Visually check that the air cleaner element for excessive dirt, damage or oil. Replace if necessary

#### Caution

**Do not clean the air cleaner element with compressed air.**

### Engine Oil

Check the engine oil level and condition with the oil level gauge.

Add oil, or change it, if necessary.

# 1A TUNE-UP PROCEDURE

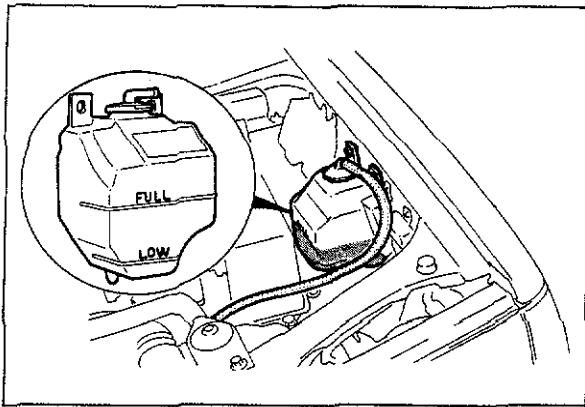

4BG01A-009

## Coolant Level

Check that the coolant level is near the radiator inlet port, and that the level in the reserve tank is between the FULL and LOW marks.

Add coolant if the level is low.

### Warning

**Never remove the radiator cap while the engine is hot.**

**Wrap a thick cloth around the cap and carefully remove the cap.**

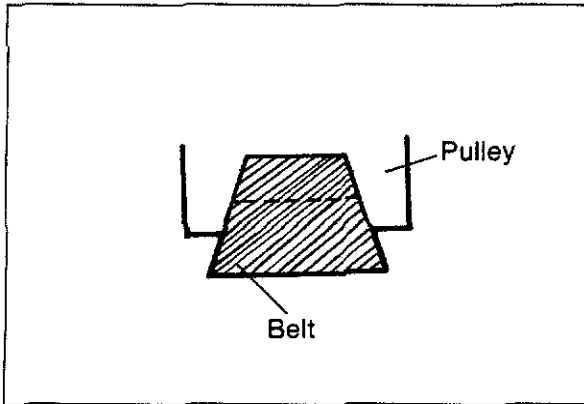

83U01A-005

## Drive Belt

1. Check that the drive belt is positioned in the pulley groove.
2. Check the drive belt for wear, cracks, or fraying.
3. Check the pulley for damage.

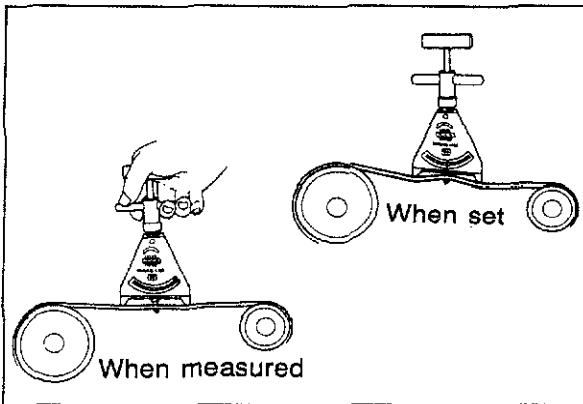

83U01A-006

## Inspection of belt tension

Check the drive belt tension by using the tension gauge.

### Standard tension

**N (kg, lb)**

Belt	New	Used
Alternator	491—589 (50—60, 110—132)	422—491 (43—50, 95—110)
A/C	491—589 (50—60, 110—132)	422—461 (43—50, 95—110)
P/S	491—589 (50—60, 110—132)	422—491 (43—50, 95—110)
A/C and P/S	491—589 (50—60, 110—132)	422—491 (43—50, 95—110)

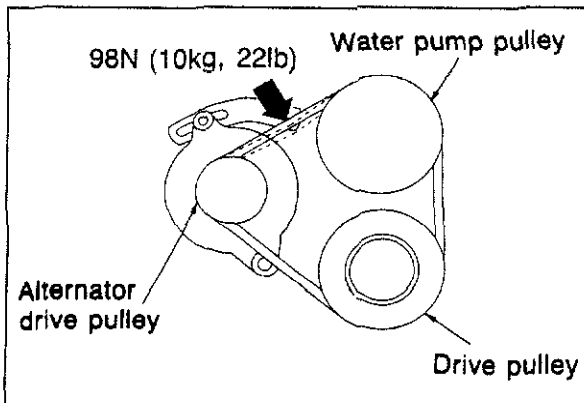

83U01A-007

## Inspection of belt deflection

Check the drive belt deflection by applying moderate pressure (98 N, 10 kg, 22 lb) midway between the pulleys.

### Alternator drive belt

**New: 8—9 mm (0.31—0.35 in)**

**Used: 9—10 mm (0.35—0.39 in)**

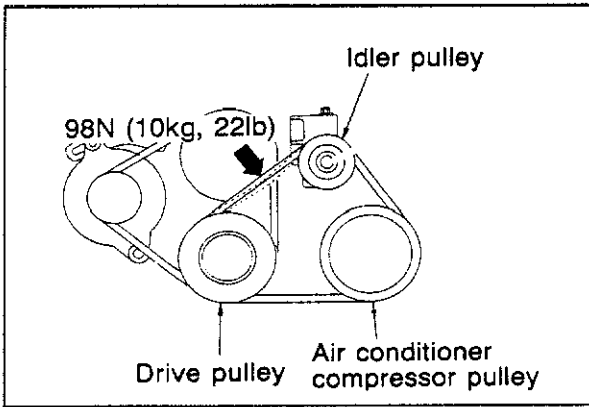

83U01A-008

A/C drive belt

**New: 8—9 mm (0.31—0.35 in)**  
**Used: 9—10 mm (0.35—0.39 in)**

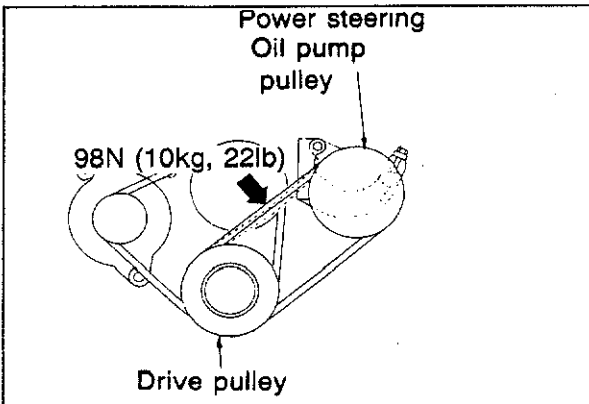

83U01A-009

P/S oil pump drive belt

**New: 8—9 mm (0.31—0.35 in)**  
**Used: 9—10 mm (0.35—0.39 in)**

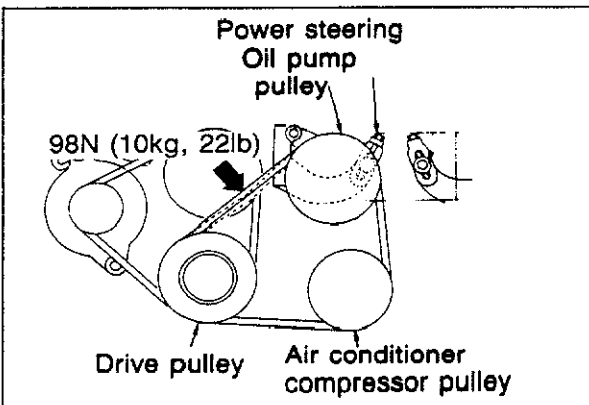

83U01A-010

A/C and P/S oil pump drive belt

**New: 8—9 mm (0.31—0.35 in)**  
**Used: 9—10 mm (0.35—0.39 in)**

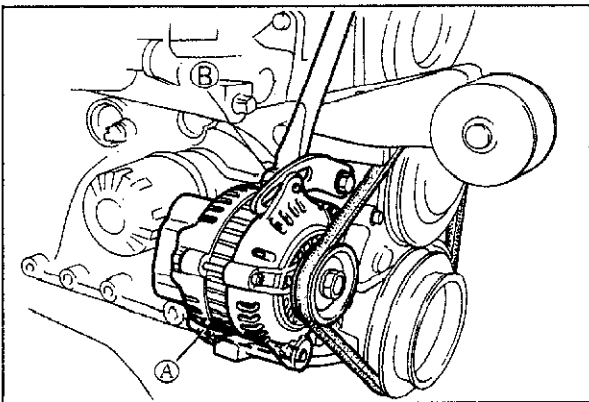

83U01A-011

**Adjustment of belt deflection**

Alternator drive belt

1. Loosen the alternator mounting bolt A and adjusting bolt B.
2. Lever the alternator outward and apply tension to the belt.
3. Tighten the adjusting bolt B.

**Tightening torque:**  
**19—26 N·m (1.9—2.6 m·kg, 14—19 ft·lb)**

4. Tighten the mounting bolt A.

**Tightening torque:**  
**37—52 N·m (3.8—5.3 m·kg, 27—38 ft·lb)**

5. Recheck the belt tension or deflection.



# 1A TUNE-UP PROCEDURE

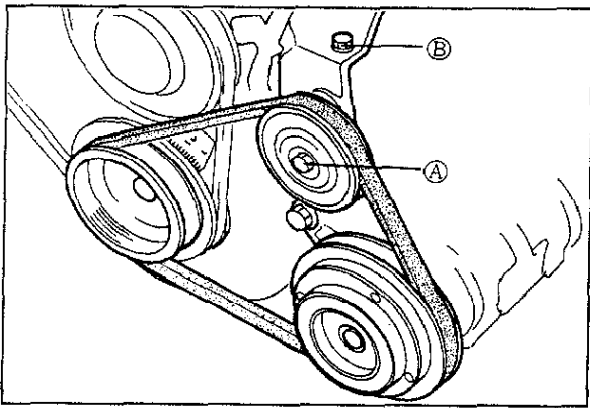

83U01A-012

## A/C drive belt

1. Loosen the idler pulley lock bolt A.
2. Adjust the belt tension and deflection by turning the adjusting bolt B.
3. Tighten the idler pulley lock bolt A.

### Tightening torque:

**31—46 N·m (3.2—4.7 m·kg, 24—34 ft·lb)**

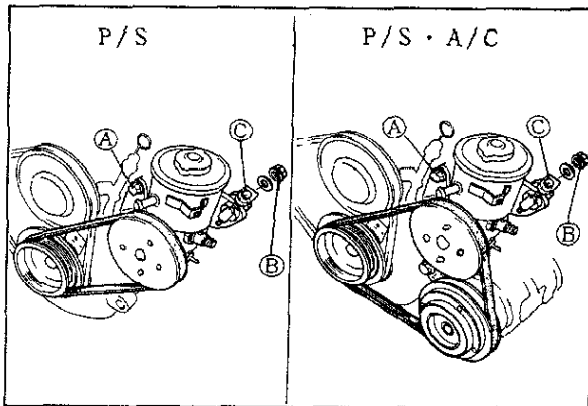

83U01A-013

## P/S oil pump drive belt, A/C and P/S oil pump drive belt

1. Loosen the mounting bolt A and adjusting bolt lock nut B.
2. Adjust the belt tension and deflection by turning the adjusting bolt C.
3. Tighten the adjusting bolt lock nut B and mounting bolt A.

### Tightening torque:

**Bolt A: 31—46 N·m  
(3.2—4.7 m·kg, 24—34 ft·lb)**

**Nut B: 36—54 N·m  
(3.7—5.5 m·kg, 27—40 ft·lb)**

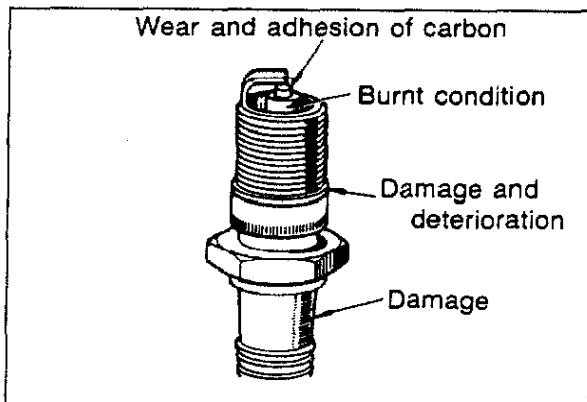

63U01X-010

## Spark Plug

Check the following points, clean or replace if necessary.

1. Damaged insulation
2. Worn electrodes
3. Carbon deposits
4. Damaged gasket
5. Burnt spark insulator
6. Plug gap

### Standard plug gap:

**1.00—1.10 mm (0.039—0.043 in)**

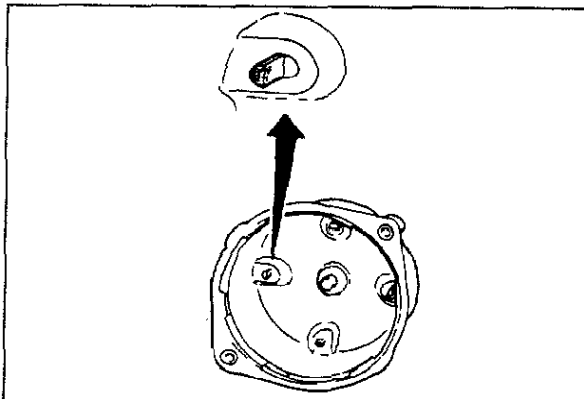

4BG01A-015

## Distributor Cap

Check the following points. If necessary, replace the distributor cap.

1. Cracks, carbon deposits
2. Burnt or corroded terminals
3. Worn distributor center contact

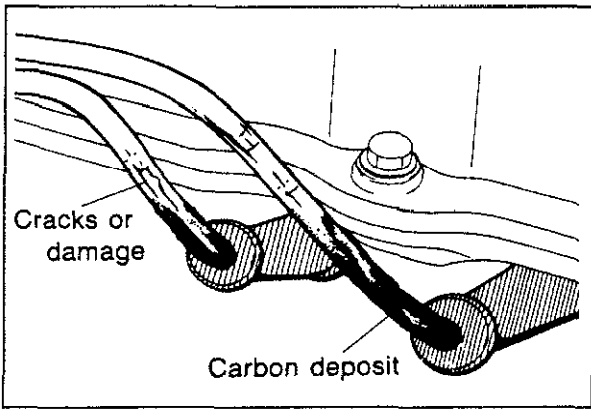

4BG01A-016

## High-tension Lead

Check the following points, if necessary clean or replace.

1. Damaged lead
2. Carbon deposits

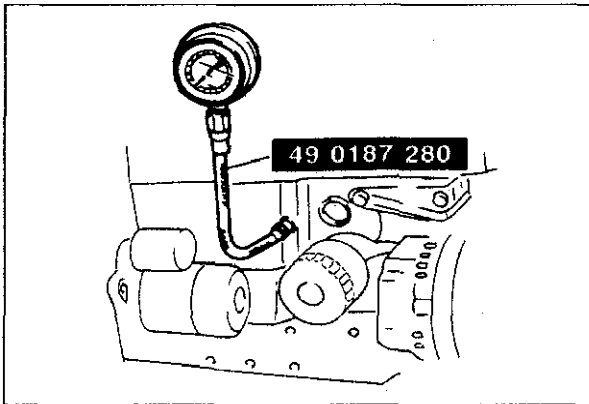

83U01A-014

## Hydraulic Lash Adjuster

### Note

Tapet noise may occur if the engine is not operated for an extended period of time. The noise should disappear after the engine has reached normal operating temperature.

1. Check for tappet noise, if noise exists, check the followings:
  - (1) Engine oil condition and level
  - (2) Engine oil pressure (Refer to section 2A)
2. If the noise does not disappear, check for movement of the HLA by pushing down each rocker arm by hand.
3. If the rocker arm moves down, replace the HLA. (Refer to page 1A—61)

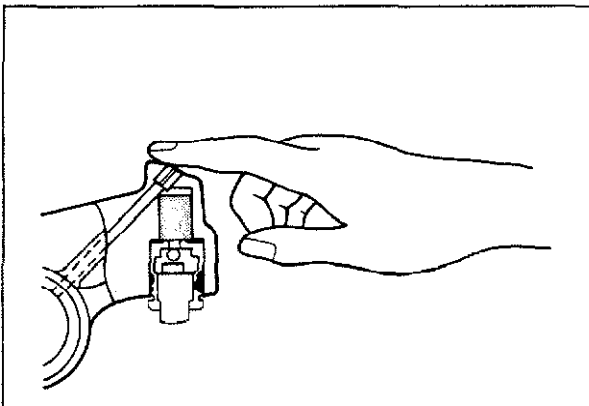

83U01A-015

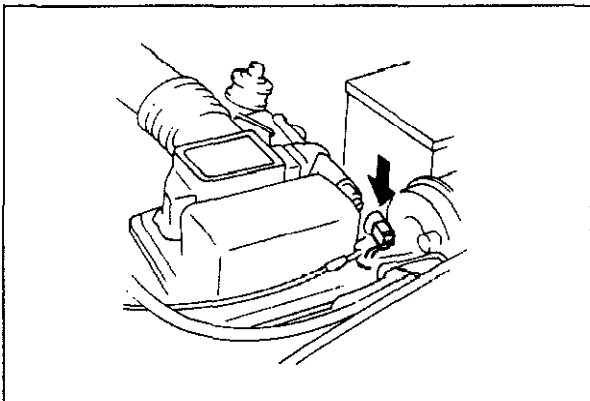

4BG01A-012

## Compression

1. Warm up the engine to operating temperature.
2. Turn it off for about 10 minutes to reduce the exhaust pipe temperature.
3. Remove all spark plugs.
4. Disconnect the primary wire connector from the ignition coil.

# 1A TUNE-UP PROCEDURE

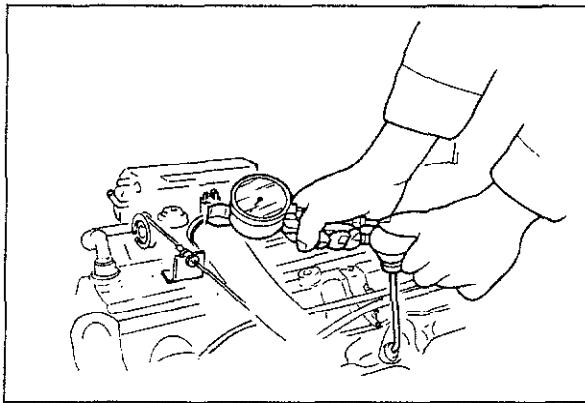

83U01A-016

5. Connect a compression gauge to the No. 1 spark plug hole.
6. Fully depress the accelerator pedal and crank the engine.
7. Check whether the gauge reads within the limits.

### Standard compression:

**1,324 kPa (13.5 kg/cm<sup>2</sup>, 192 psi)**

### Compression limit:

**932 kPa (9.5 kg/cm<sup>2</sup>, 135 psi)**

8. Check each cylinder.
9. Refit the primary wire connector securely to the ignition coil.
10. Install the spark plugs and high-tension leads.

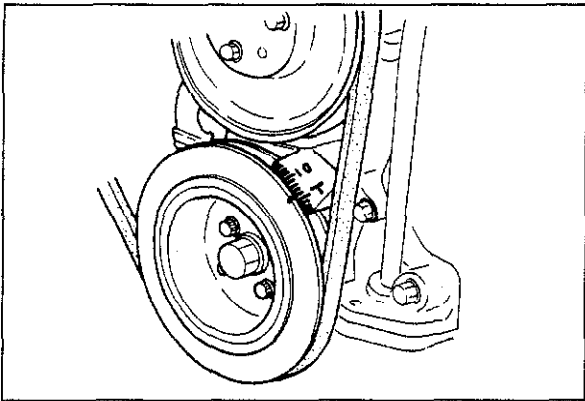

83U01A-017

### Ignition Timing

1. Warm up the engine and run it at idle.
2. Turn all electric loads OFF.
3. Connect a timing light tester.
4. Disconnect the vacuum hose from the vacuum control, and plug the hose.
5. Disconnect the black connector at distributor.
6. Check that the ignition timing mark (yellow) on the crankshaft pulley and the timing mark on the timing belt cover are aligned.

**Ignition timing: 2 ± 1° BTDC**

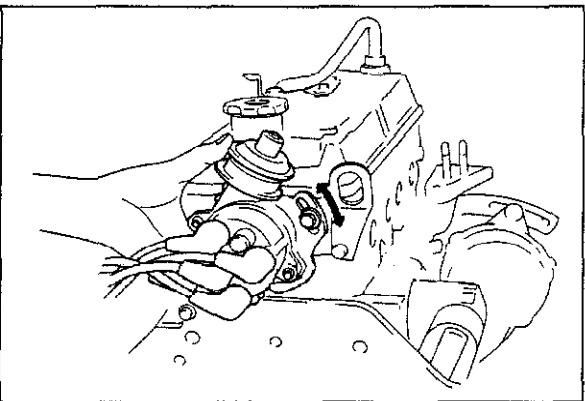

83U01A-018

7. If necessary, adjust the ignition timing by turning the distributor.
8. Reconnect the vacuum hose and the black connector at distributor.

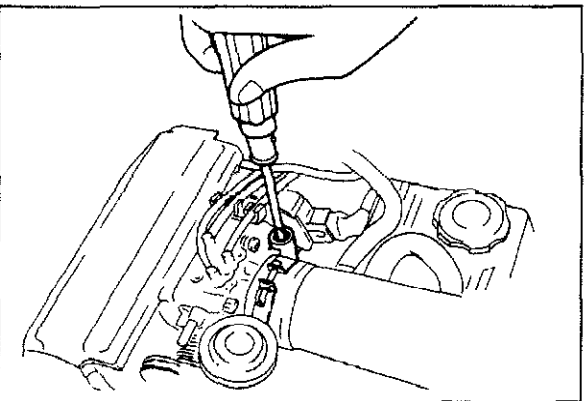

83U01A-019

### Idle Speed

1. Connect a tachometer to the engine.
2. Turn off all lights and other unnecessary electrical loads.
3. Check the idle speed. If necessary, turn the air adjust screw and adjust to specifications.

### Idle speed

**MTX: 850 ± 50 rpm (in neutral)**

**ATX: 850 ± 50 rpm (in "P" range)**

**ON-VEHICLE MAINTENANCE**

**TIMING BELT**

**Removal**

1. Disconnect the battery negative cable.
2. Remove the parts in the numbered sequence shown in the figure.

83U01A-020

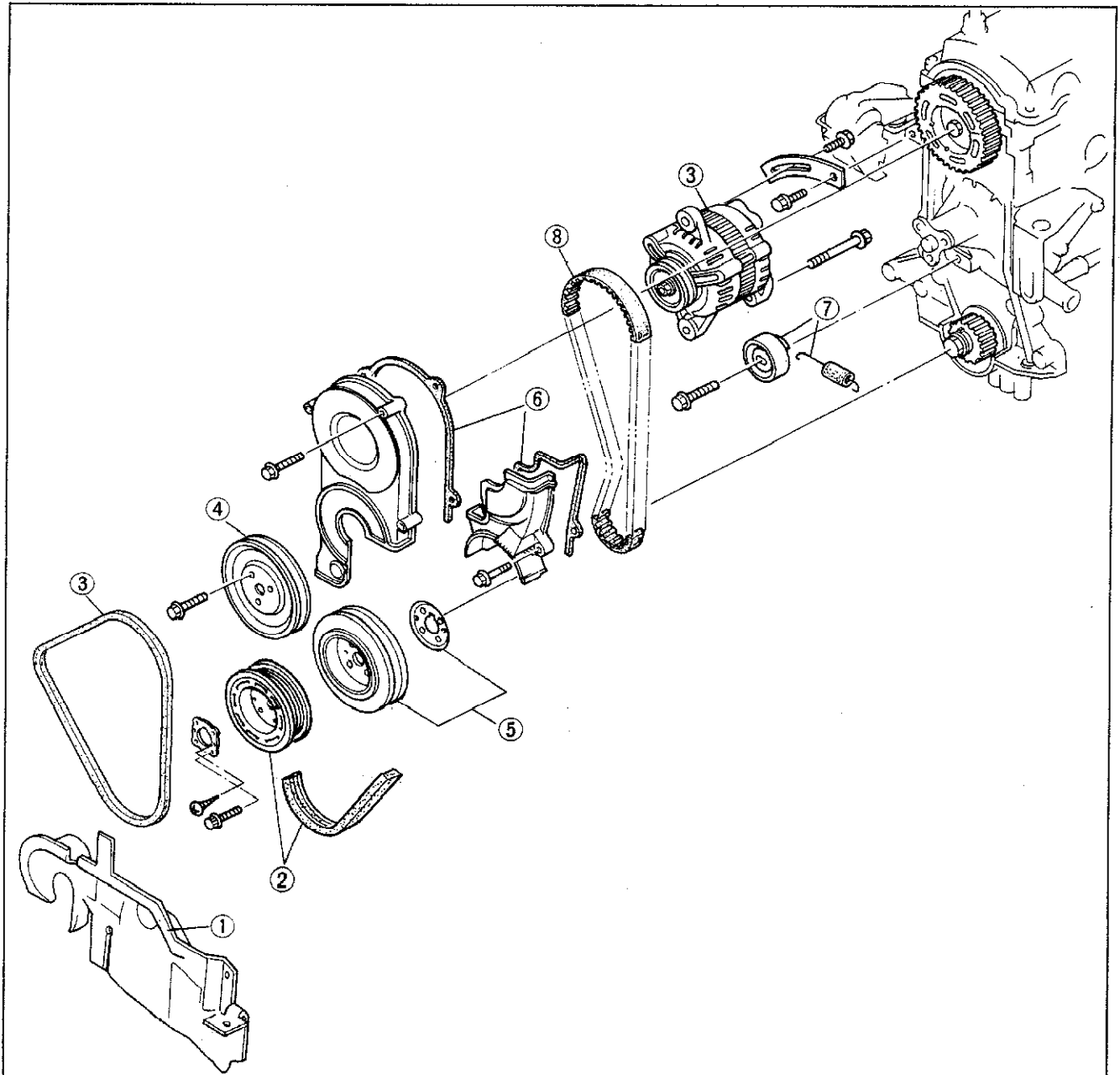

83U01A-021

- |   |  |
|---|--|
| <ol style="list-style-type: none"> <li>1. Engine side cover</li> <li>2. A/C and P/S drive belt and pulley</li> <li>3. Alternator and alternator drive belt</li> <li>4. Water pump pulley</li> </ol> | <ol style="list-style-type: none"> <li>5. Crankshaft pulley and baffle plate</li> <li>6. Upper and lower timing belt cover</li> <li>7. Timing belt tensioner and spring</li> <li>8. Timing belt</li> </ol> |
|---|--|

**Note**

**Remove the No.3 engine mount installation nuts and lower the engine to remove A/C and P/S pulley and the crankshaft pulley.**

# 1A ON-VEHICLE MAINTENANCE (TIMING BELT)

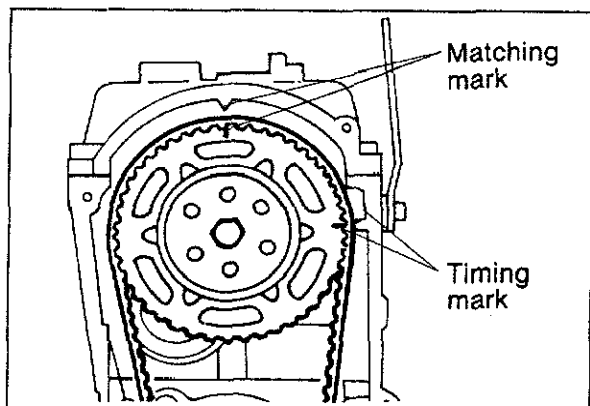

63U01X-018

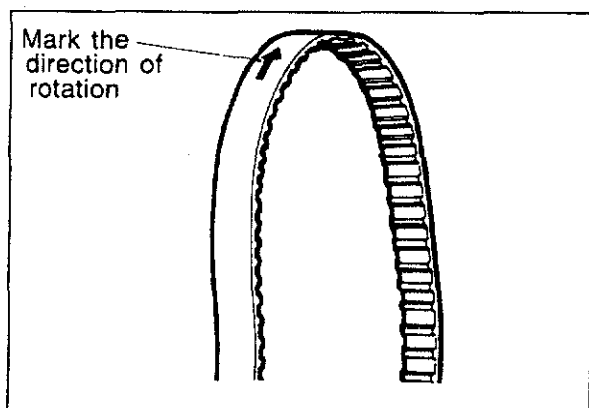

83U01A-131

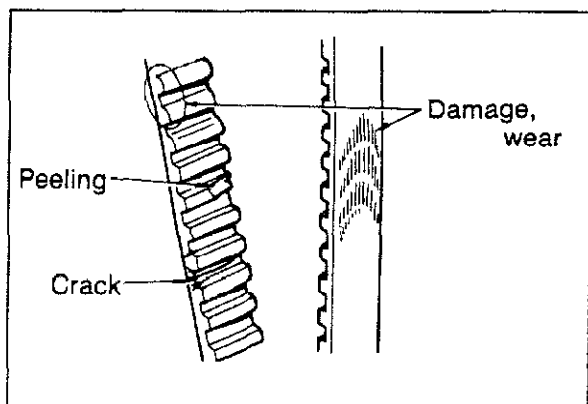

83U01A-022

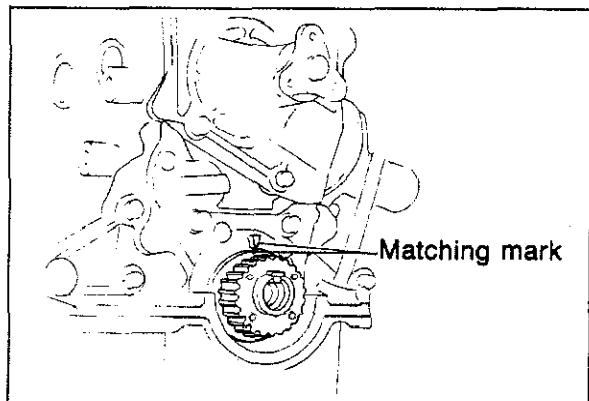

4BG01A-031

Before removing the timing belt, do the following:

1. Turn the crankshaft to align the matching mark of the camshaft pulley with the cylinder head and the cylinder head cover timing mark.

2. Mark the direction of rotation on the timing belt.

### Note

The direction arrow is so the belt can be reinstalled in the same direction.

3. Remove the timing belt.

### Caution

Do not allow any oil or grease on the timing belt.

### Inspection

Referring to page 1A—49, inspect the following parts:

1. Timing belt
2. Timing belt tensioner and spring
3. Timing belt pulley
4. Camshaft pulley

### Installation

1. Be sure that the timing mark on the timing belt pulley is aligned with the matching mark.

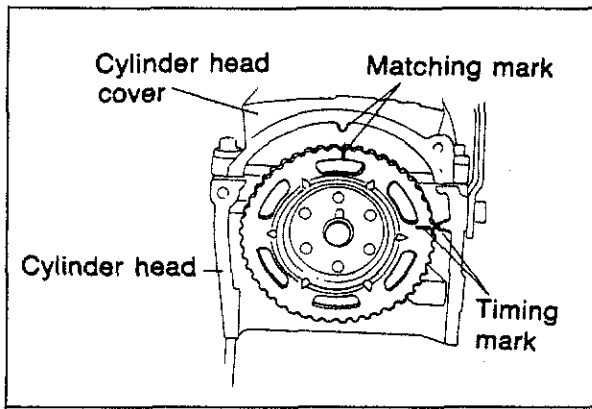

63U01X-021

2. Be sure that the matching mark on the camshaft pulley is aligned with the cylinder head cover matching mark. If it is not aligned, turn the camshaft to align.

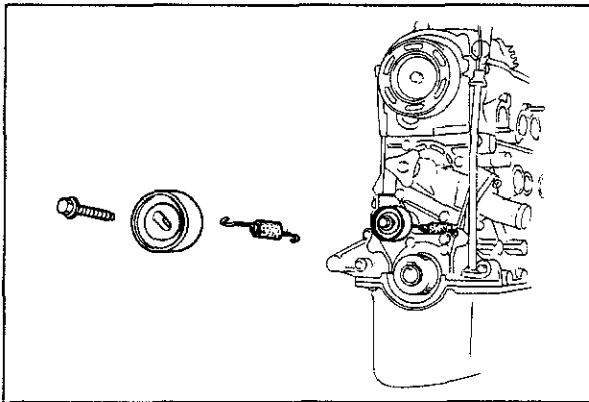

4BG01A-033

3. Install the timing belt tensioner and spring. Temporarily secure it so the spring is fully extended.

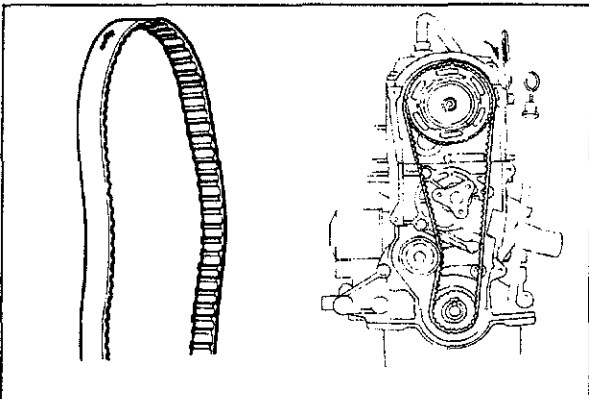

61G01X-100

4. Install the timing belt.

### Caution

- a) The timing belt must be reinstalled in the same direction of previous rotation if it is reused.
- b) Be sure that there is no oil, grease, or dirt on the timing belt.

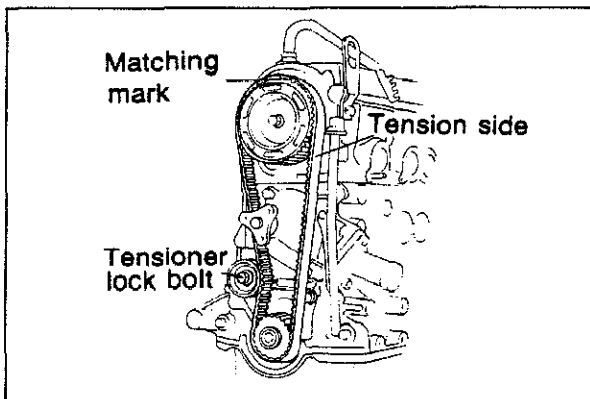

83U01X-137

### Note

**Remove all spark plugs for easier rotation.**

5. Turn the crankshaft twice in the direction of rotation. (Clockwise)
6. Check that the timing marks are correctly aligned. If not repeat the above-mentioned procedure.
7. Loosen the tensioner lock bolt and apply tension to the belt.

# 1A ON-VEHICLE MAINTENANCE (TIMING BELT)

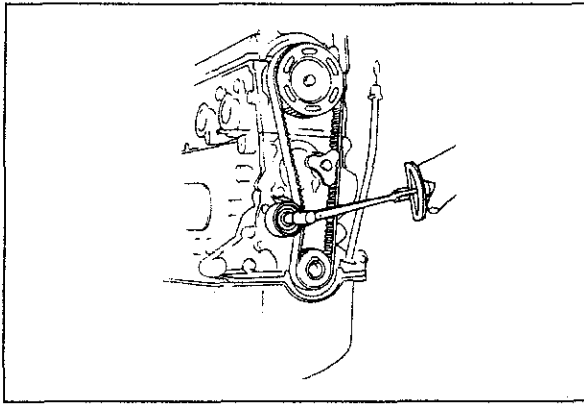

83U01A-129

8. Tighten the timing belt tensioner to specification.

**Tightening torque:**

**19—26 N·m (1.9—2.6 m·kg, 14—19 ft·lb)**

9. Turn the crankshaft twice in the direction of rotation and check the matching marks for alignment.

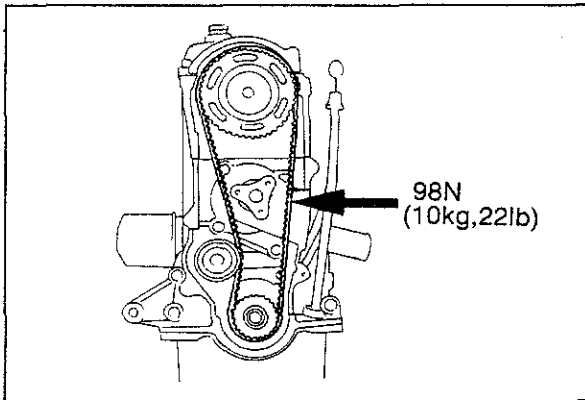

83U01A-023

10. Measure the tension between the crankshaft pulley and the camshaft pulley.

If the timing belt tension is not correct, temporarily secure tensioner lock bolt so the spring is fully extended and repeat steps 5—9 above or replace the tensioner spring.

**Timing belt deflection:**

**12—13 mm (0.47—0.51 in)**

**/ 98 N (10 kg, 22 lb)**

**Caution**

**Be sure not to apply tension other than that of the tensioner spring.**

11. Install the lower and upper timing belt cover.

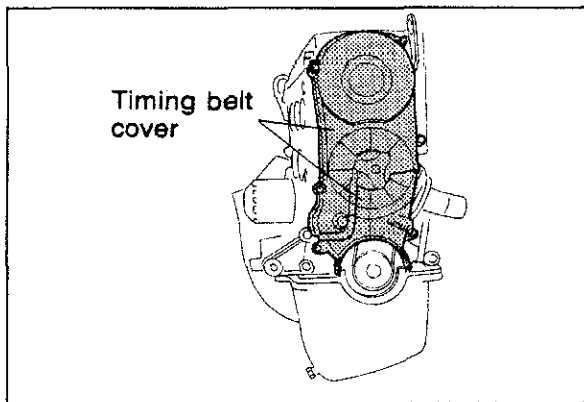

83U01A-130

**Tightening torque:**

**8—11 N·m (0.8—1.1 m·kg, 69—95 in·lb)**

12. Install the spark plugs.

**Tightening torque:**

**15—23 N·m (1.5—2.3 m·kg, 11—17 ft·lb)**

13. Install the baffle plate and the crankshaft pulley.

**Tightening torque: 12—17 N·m**

**(1.25—1.75 m·kg, 109—152 in·lb)**

14. Install the No.3 engine mount bracket.

**Tightening torque:**

**60—85 N·m (6.1—8.7 m·kg, 44—63 ft·lb)**

15. Install the drive belt and adjust the belt tension (refer to page 1A—6).

16. Install the engine side cover.

17. Connect the battery negative cable.

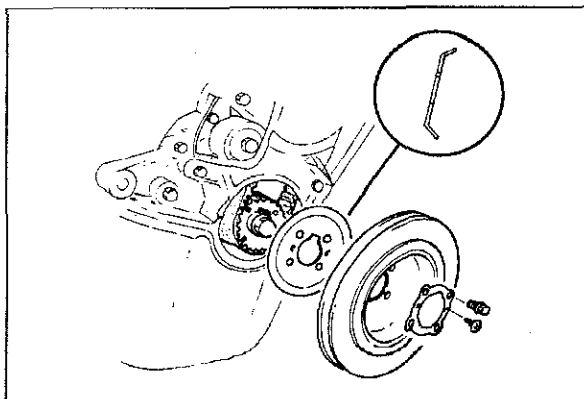

83U01A-024

## CYLINDER HEAD

### Removal

#### Warning

Release the fuel pressure (Refer to FUEL PRESSURE RELEASE of FUEL SYSTEM section).

1. Disconnect the battery negative cable.
2. Drain the coolant.
3. Remove the parts in the numbered sequence shown in the figure.

83U01A-025

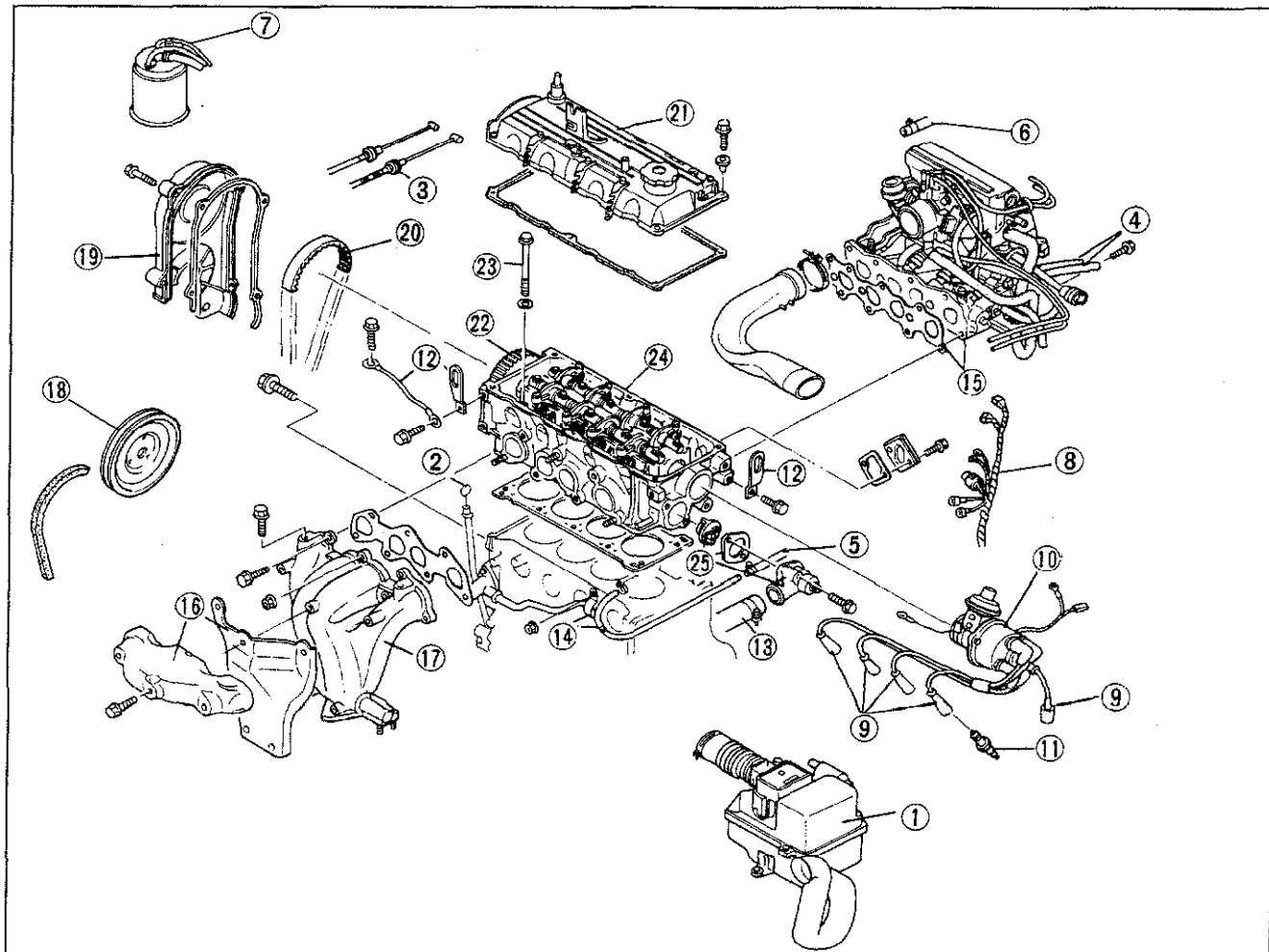

83U01A-026

- |   |                                   |                                |
|---|-----------------------------------|--------------------------------|
| 1. Air cleaner assembly                       | 9. High-tension leads             | 16. Exhaust manifold insulator |
| 2. Oil level gauge                            | 10. Distributor                   | 17. Exhaust manifold           |
| 3. Accelerator cable and cruise control cable | 11. Spark plugs                   | 18. Water pump pulley          |
| 4. Fuel hoses                                 | 12. Engine hanger and ground wire | 19. Upper timing belt cover    |
| 5. Heater hoses                               | 13. Upper radiator hose           | 20. Timing belt                |
| 6. Brake vacuum hose                          | 14. Water bypass hose and bracket | 21. Cylinder head cover        |
| 7. Canister hose                              | 15. Intake manifold assembly      | 22. Camshaft pulley            |
| 8. Engine harness connectors                  |                                   | 23. Cylinder head bolts        |
|   |                                   | 24. Cylinder head              |
|   |                                   | 25. Thermostat assembly        |



# 1A ON-VEHICLE MAINTENANCE (CYLINDER HEAD)

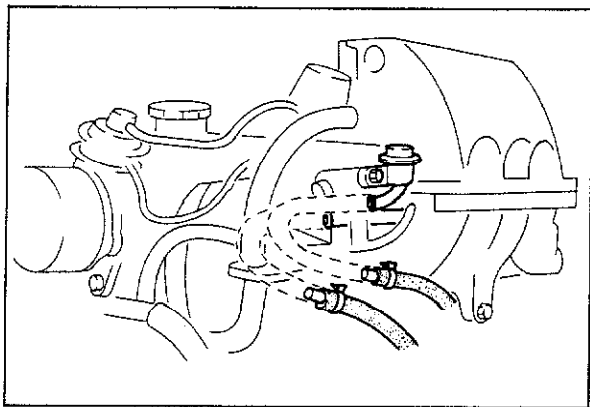

4BG01A-051

## Fuel hose

After disconnecting the inlet and return fuel hoses, plug them.

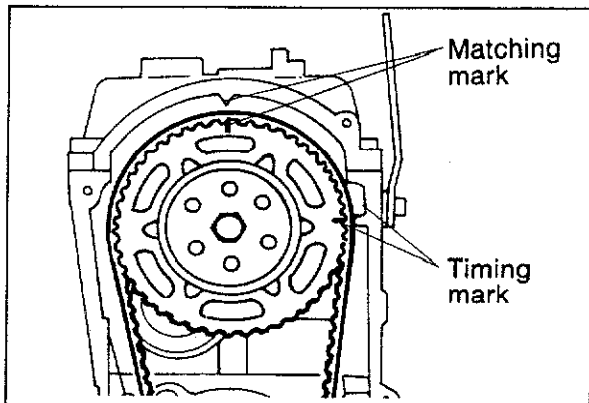

61G01X-009

## Timing belt

1. Before removal of timing belt, turn the crankshaft to align the matching mark on the camshaft pulley with the matching mark on the cylinder head cover.

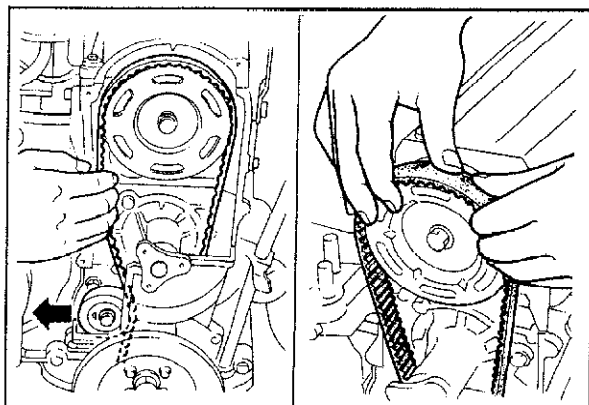

83U01A-133

2. Loosen the timing belt tensioner lock bolt.

3. Pull the tensioner in the direction indicated by arrow and temporarily tighten the lock bolt.

4. Remove the timing belt.

## Caution

**Do not allow any oil or grease on the timing belt.**

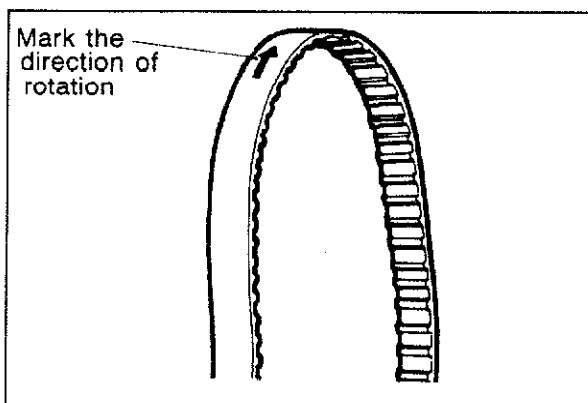

61G01X-011

5. Mark the forward direction arrow on the timing belt.

## Note

**Direction arrow is for reassembling the timing belt in the same direction.**

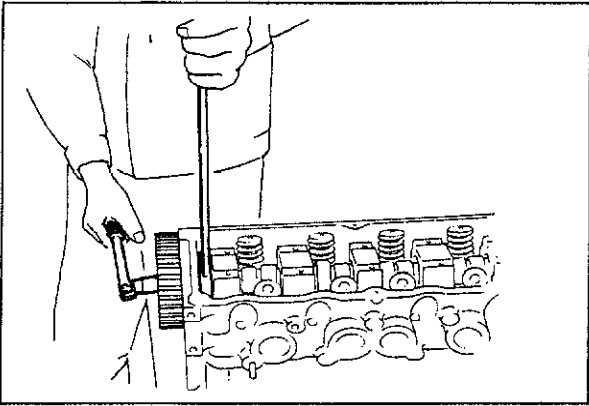

61G01X-108

### Camshaft pulley

1. Remove the cylinder head cover.
2. Hold the camshaft using a suitable wrench on the cast hexagon.
3. Remove the camshaft pulley.

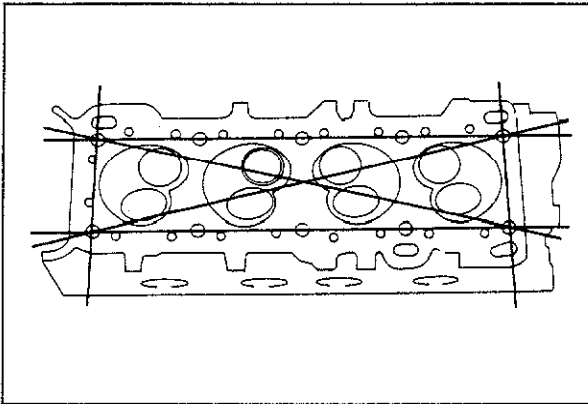

83U01A-027

### Disassembly of Cylinder Head

Refer to page 1A—32

### Inspection

Refer to page 1A—37

### Assembly

Refer to page 1A—59

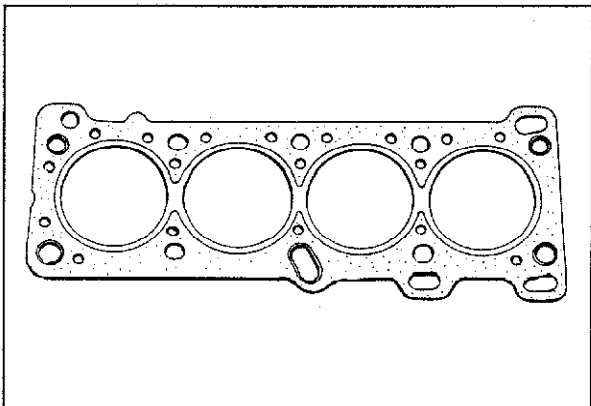

63U01X-033

### Installation

1. Thoroughly remove all dirt and grease from the top of the cylinder block with a rag.
2. Place the new cylinder head gasket in position.

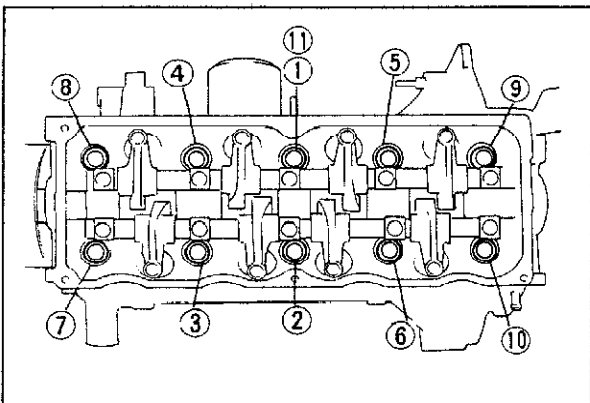

63U01X-034P

3. Install the cylinder head, and tighten the cylinder head bolts gradually in the order shown in the figure.

### Tightening torque:

**75—81 N·m (7.7—8.3 m·kg, 56—60 ft·lb)**

# 1A ON-VEHICLE MAINTENANCE (CYLINDER HEAD)

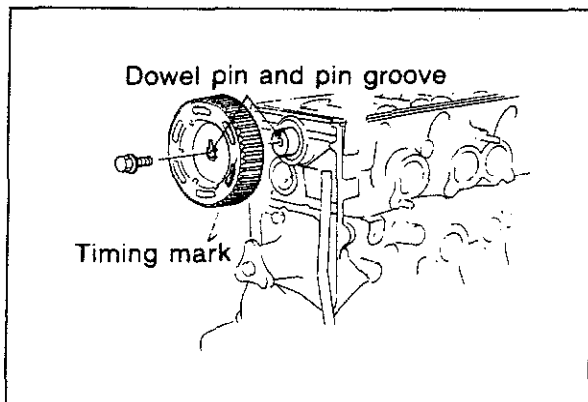

83U01A-028

4. Install the camshaft pulley onto the dowel pin and keyway with the matching mark straight up, so that the timing marks on the camshaft pulley and cylinder head align.

**Tightening torque:**

**49—61 N·m (5.0—6.2 m·kg, 36—45 ft·lb)**

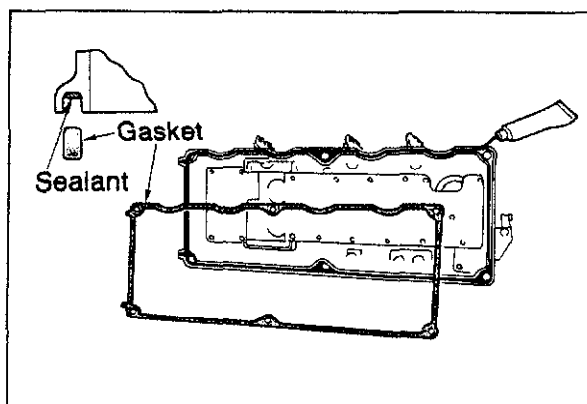

83U01A-029

5. Apply a coat of sealant to the cylinder head cover as shown in the figure.

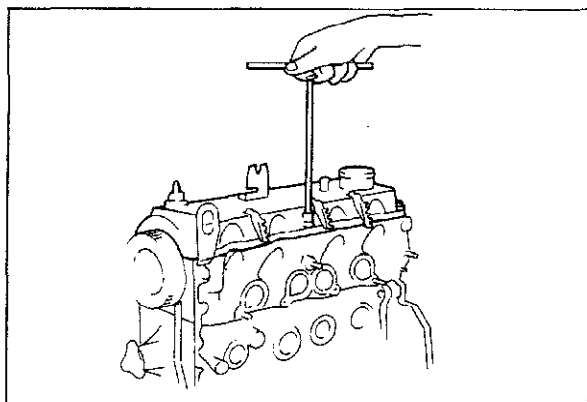

6. Install the cylinder head cover.

**Tightening torque:**

**5—9 N·m (0.5—0.9 m·kg, 43—78 in·lb)**

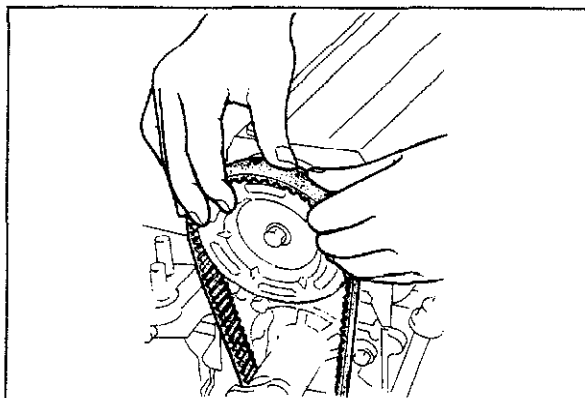

7. Install the timing belt (Refer to page 1A—11).

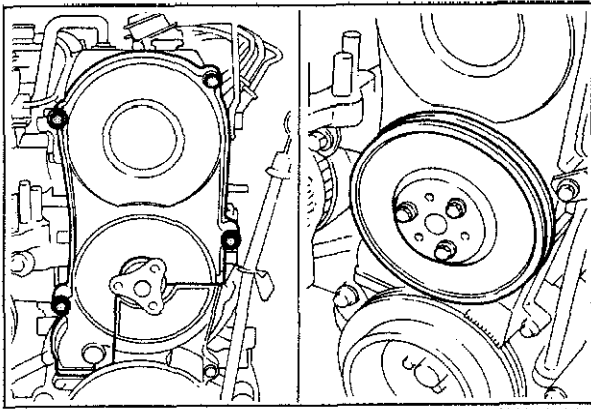

83U01A-032

8. Install the upper timing belt cover.

**Tightening torque:**

**8—11 N·m (0.8—1.1 m·kg, 69—95 in·lb)**

9. Install the water pump pulley.

**Tightening torque:**

**8—11 N·m (0.8—1.1 m·kg, 69—95 in·lb)**

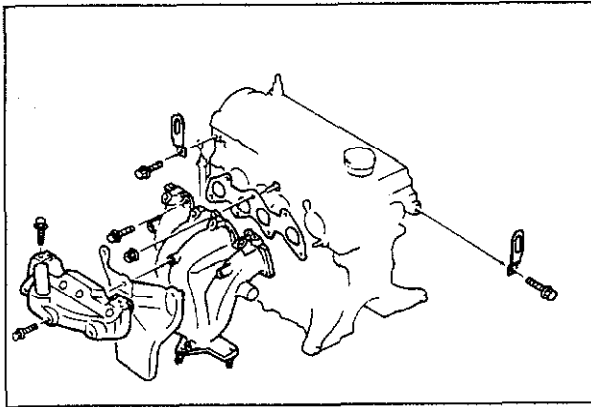

83U01A-033

10. Install engine ground, front and rear engine hanger.

**Tightening torque:**

**Front: 37—63 N·m  
(3.8—6.4 m·kg, 27—46 ft·lb)**

**Rear: 19—30 N·m  
(1.9—3.1 m·kg, 14—22 ft·lb)**

11. Install the exhaust manifold.

**Tightening torque:**

**16—23 N·m (1.6—2.3 m·kg, 12—17 ft·lb)**

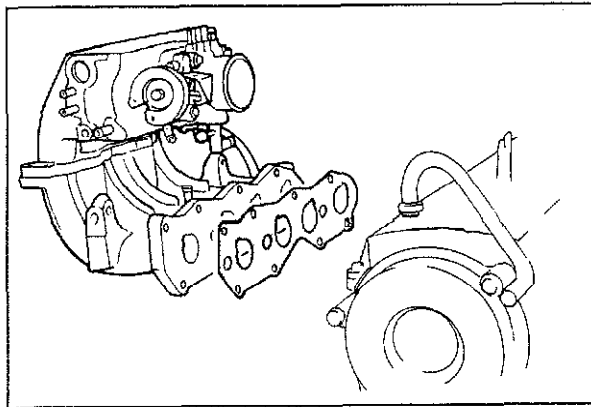

83U01A-034

12. Install the exhaust manifold insulator.

13. Install the water bypass hose bracket.

14. Install the intake manifold assembly.

**Tightening torque:**

**19—26 N·m (1.9—2.6 m·kg, 14—19 ft·lb)**

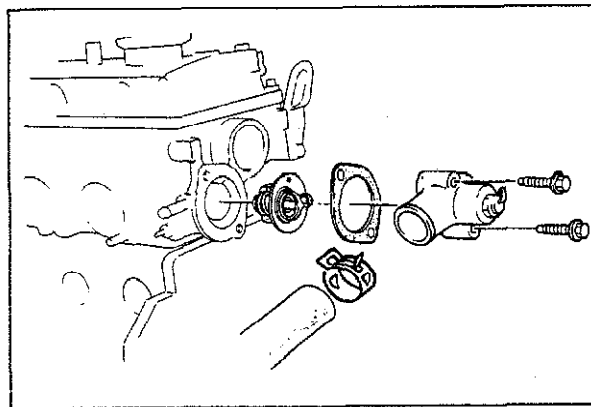

83U01A-035

15. Install the thermostat assembly. (Refer to 1A—66.)

16. Connect the upper radiator hose.

**Note**

**Position the hose clamp in the original location on the hose and squeeze it lightly with large pliers to ensure a good fit.**

# 1A ON-VEHICLE MAINTENANCE (CYLINDER HEAD)

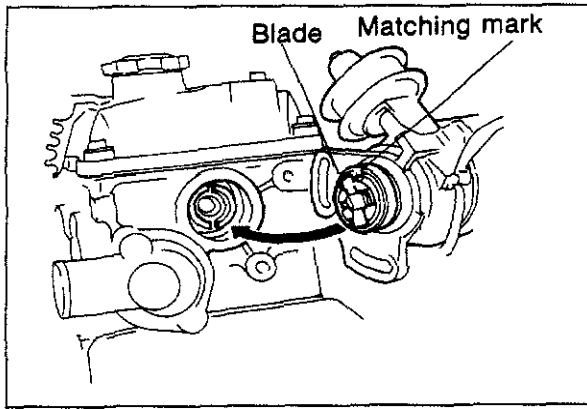

83U01A-036

17. Align the distributor blade with the small oil holes, then install the distributor by referring to Section 5.
18. Install the spark plugs.

### Tightening torque:

**15—23 N·m (1.5—2.3 m·kg, 11—17 ft·lb)**

19. Install the high-tension leads.

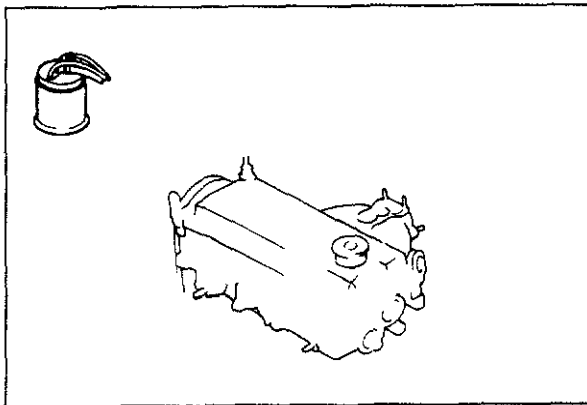

83U01A-037

20. Install the engine harness connectors.
21. Install the canister hoses.
22. Install the vacuum hoses.

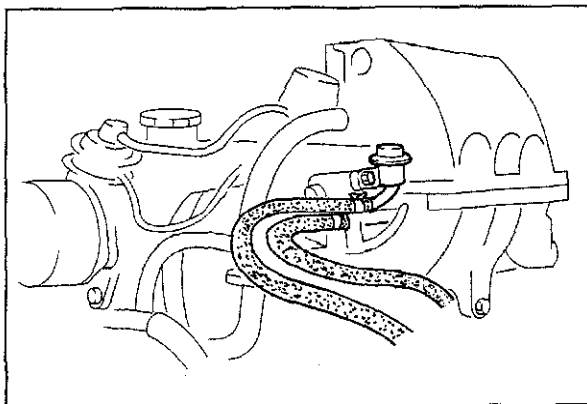

83U01A-038

23. Install the brake vacuum hose.
24. Install the heater hoses.
25. Install the fuel hose.
26. Install the accelerator cable and cruise control cable.

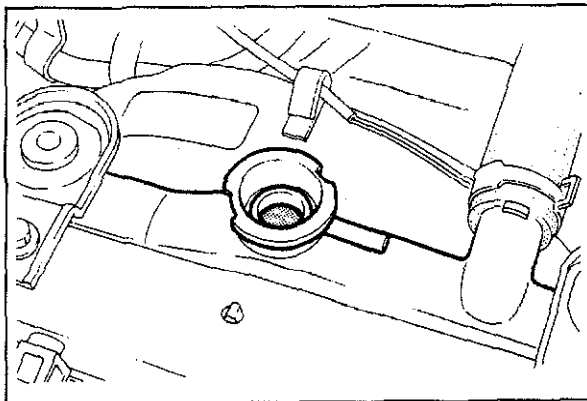

83U01A-039

27. Install the oil level gauge.
28. Install the air cleaner assembly.
29. Fill the radiator with coolant.
30. Perform the necessary engine adjustments referring to TUNE-UP PROCEDURE section.

**VALVE SEAL**

**Removal**

1. Disconnect the battery negative cable.
2. Remove each part in the numbered sequence shown in the figure.

61G01X-025

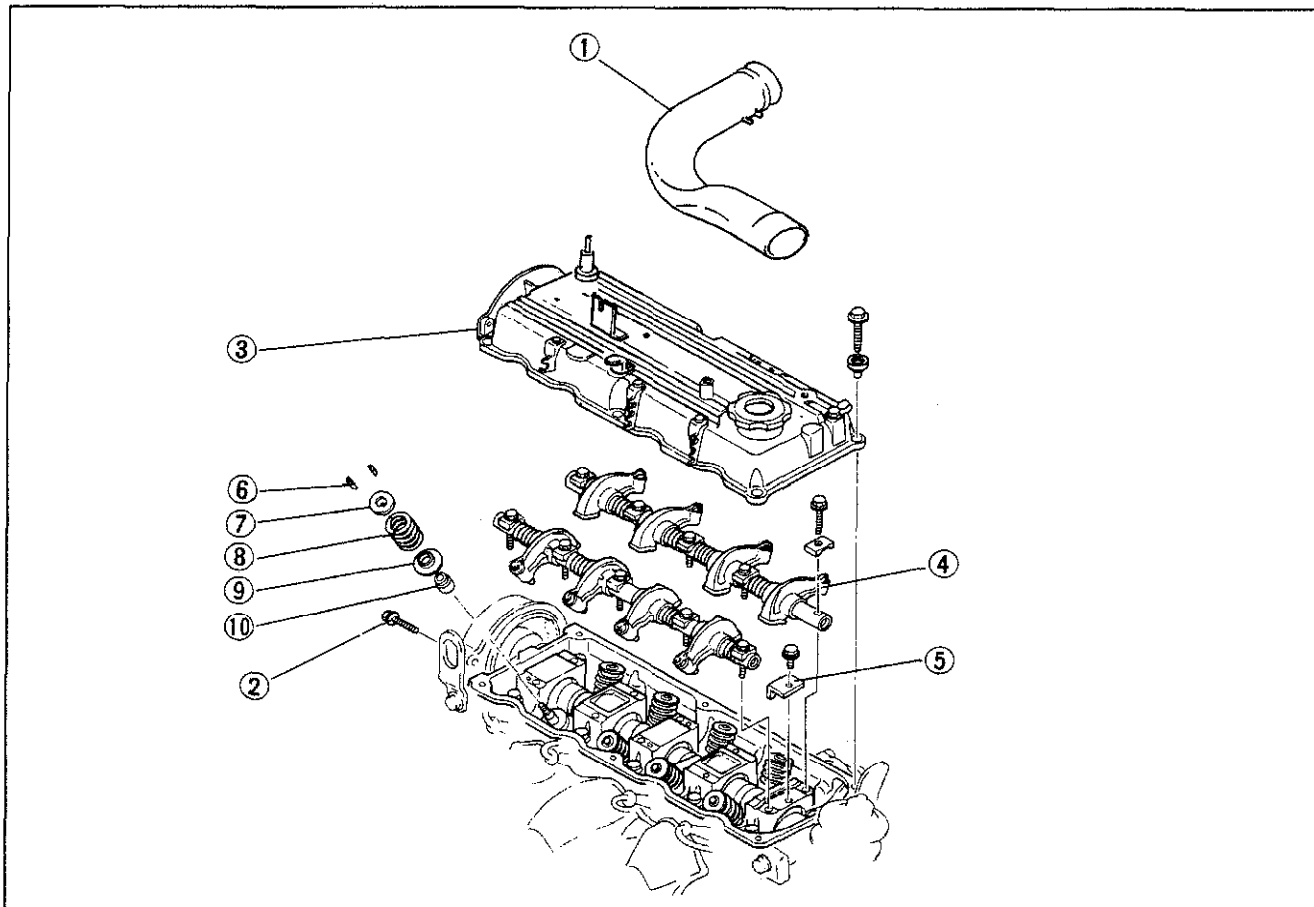

83U01A-040

- |   |                            |
|---|----------------------------|
| 1. Air intake pipe                      | 6. Spring retainer         |
| 2. Upper timing belt cover bolt         | 7. Upper valve spring seat |
| 3. Cylinder head cover                  | 8. Valve spring            |
| 4. Rocker arm and rocker shaft assembly | 9. Lower valve spring seat |
| 5. Thrust plate                         | 10. Valve seal             |

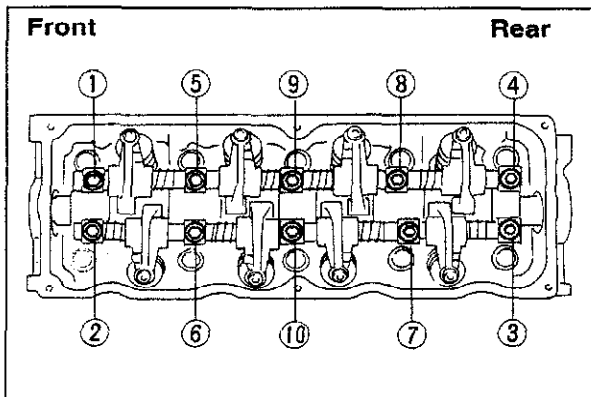

61G01X-027

**Rocker arm and rocker shaft assembly**

1. Remove the rocker arm and rocker shaft assembly by gradually loosening the bolts in the order shown in the figure.
2. Plug the oil drain hole with a rag to prevent the spring retainer from falling into the oil pan.

# 1A ON-VEHICLE MAINTENANCE (VALVE SEAL)

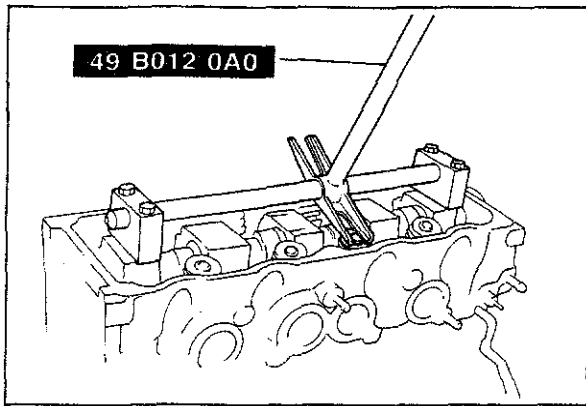

83U01X-138

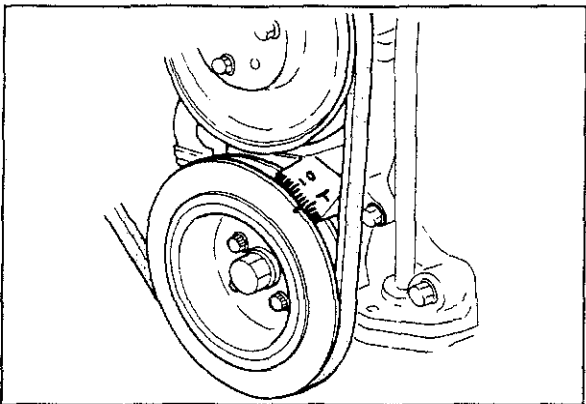

83U01X-139

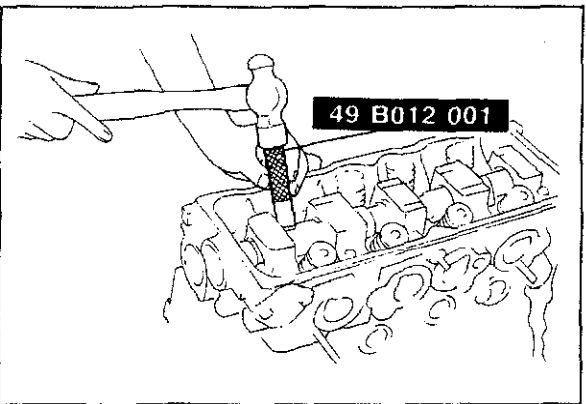

83U01X-140

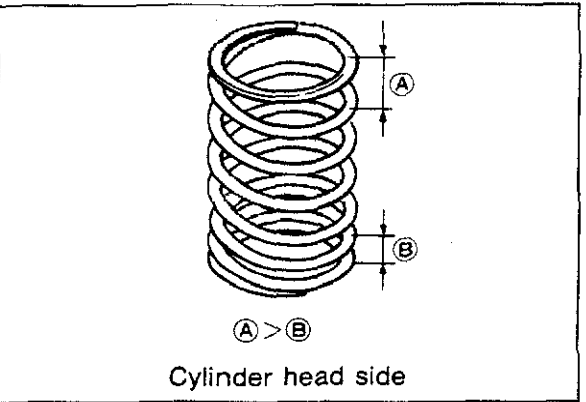

61G01X-030

## Valve seal

1. Remove the thrust plate.
2. Install the **SST** on the rocker arm shaft assembly installation hole.

3. Position the piston of the valve seal to be replaced at top dead center by turning the crankshaft pulley.
4. Remove the spring retainer by pressing down on the **SST**.
5. Remove the valve spring and spring seats (upper and lower).
6. Remove the valve seal from the valve guide with pliers or the **SST** (49 S120 170).

## Installation

1. Apply a coat of engine oil to the inner surface of the new valve seal.
2. Push it on gently, with the **SST**.

3. Install the valve spring.

## Note

**Install the valve spring with its narrow pitch end toward the cylinder head.**

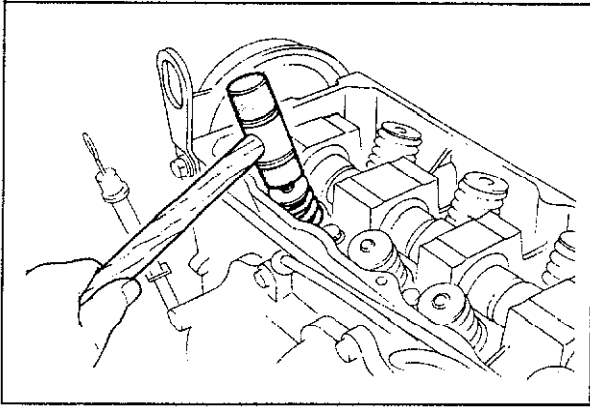

83U01X-141

4. Install the spring retainer with the **SST** (49 B012 0A0), and lightly tap the end to confirm correct assembly.

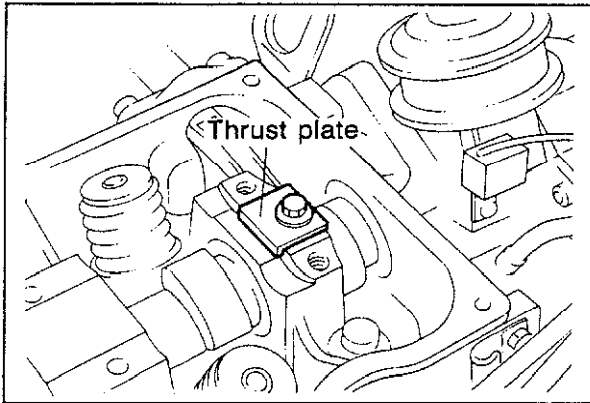

61G01X-032

5. Install the thrust plate.

**Tightening torque:**

**8—11 N·m (0.8—1.1 m·kg, 69—95 in·lb)**

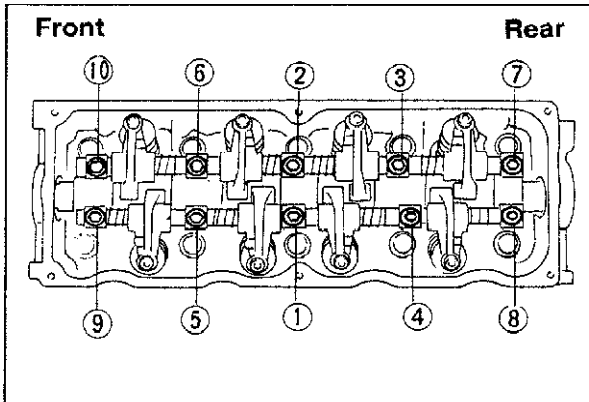

61G01X-033

6. Install the rocker arm and rocker shaft assembly on the cylinder head and tighten it gradually in the order shown in the figure.

**Note**

**Use the installation bolts for alignment when installing.**

**Tightening torque:**

**22—28 N·m (2.2—2.9 m·kg, 16—21 ft·lb)**

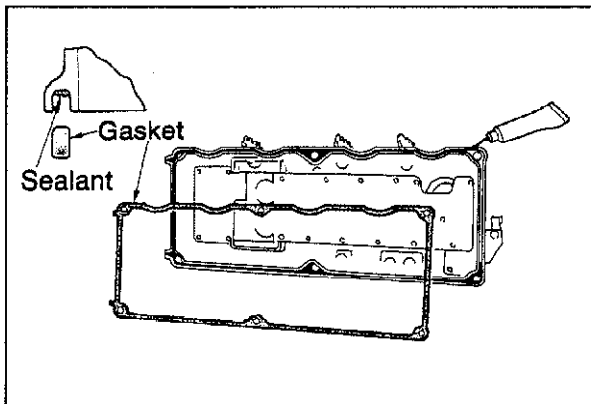

83U01A-041

7. Apply a coat of sealant to the cylinder head cover as shown in the figure.
8. Install the cylinder head cover.

**Tightening torque:**

**5—9 N·m (0.5—0.9 m·kg, 43—78 in·lb)**



# 1A ON-VEHICLE MAINTENANCE (VALVE SEAL)

---

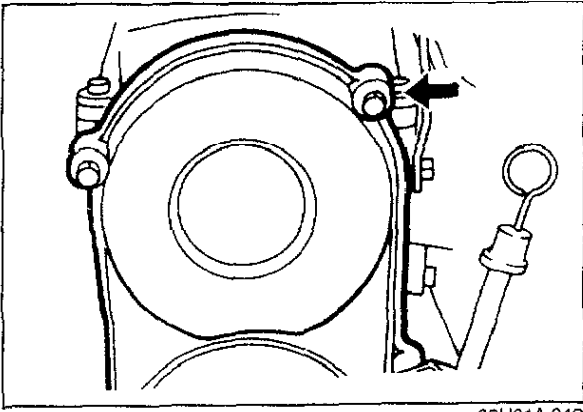

83U01A-042

9. Install the upper timing belt cover bolt.

**Tightening torque:**

**8—11 N·m (0.8—1.1 m·kg, 69—95 in·lb)**

10. Install the air intake pipe.

## REMOVAL AND INSTALLATION

**Warnig**

**Release the fuel pressure (Refer to FUEL PRESSURE RELEASE of FUEL SYSTEM section).**

1. Disconnect the battery negative cable.
2. Drain the engine oil, transaxle oil and coolant.
3. Remove the parts in the numbered sequence shown below.
4. Install in the reverse order of removal.

83U01A-043

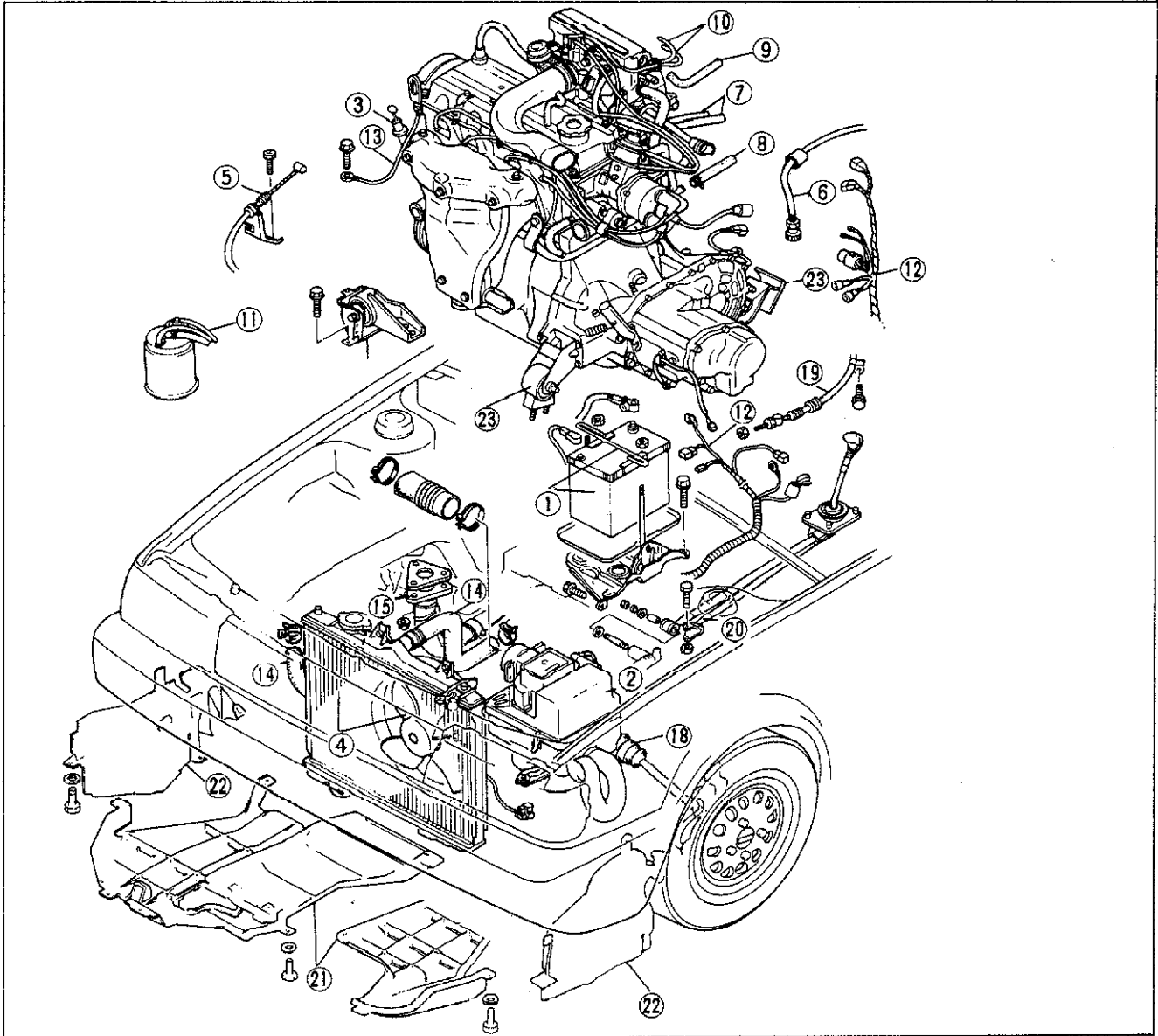

83U01A-044

- |   |                                      |   |
|---|--------------------------------------|---|
| 1. Battery and battery carrier                                    | 7. Fuel hoses                        | 16. A/C compressor<br>(if equipped)                         |
| 2. Air cleaner assembly   | 8. Heater hoses                      | 17. P/S oil pump (if equipped)                              |
| 3. Oil level gauge  | 9. Brake vacuum hose                 | 18. Driveshafts   |
| 4. Cooling fan and radiator<br>assembly                           | 10. 3-way solenoid valve hoses       | 19. Clutch control cable (MTX)                              |
| 5. Accelerator cable and<br>cruise control cable (if<br>equipped) | 11. Canister hose                    | 20. Shift control rod (MTX) or<br>shift control cable (ATX) |
| 6. Speedometer cable  | 12. Engine harness connectors        | 21. Under cover   |
|   | 13. Engine ground                    | 22. Side cover  |
|   | 14. Upper and lower radiator<br>hose | 23. Engine mount  |
|   | 15. Exhaust pipe                     |   |

# 1A REMOVAL AND INSTALLATION

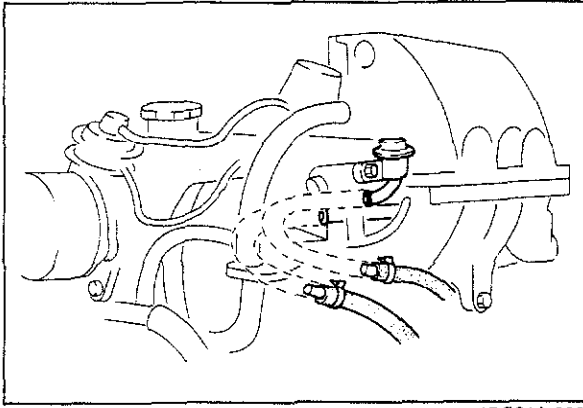

4BG01A-080

## Fuel Hose

After disconnecting the fuel hoses (inlet and return), plug them to avoid fuel leakage.

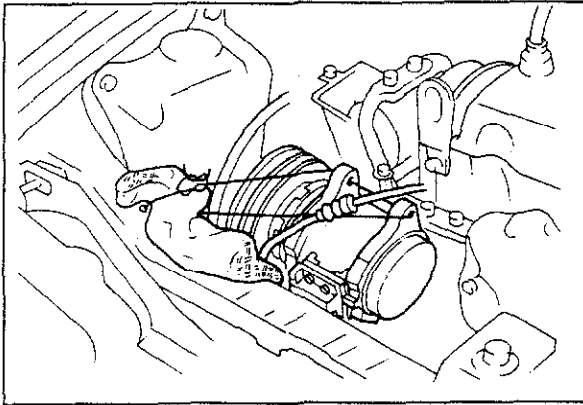

4BG01A-081

## A/C Compressor

Remove the compressor, and then, with the high-pressure and low-pressure hoses still connected to it, secure the compressor as shown in the figure.

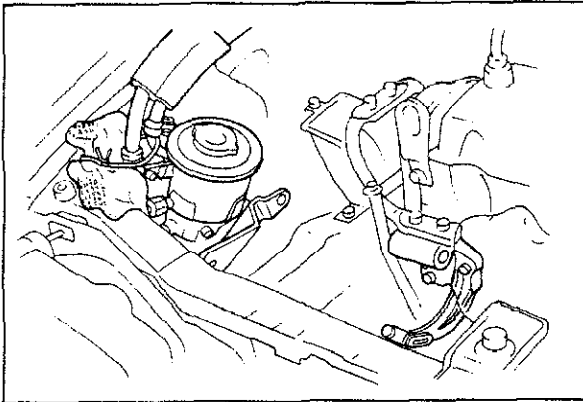

83U01A-045

## P/S Pump

Secure the P/S pump as shown in the figure. Be careful not to damage the pipe when the engine is removed and installed.

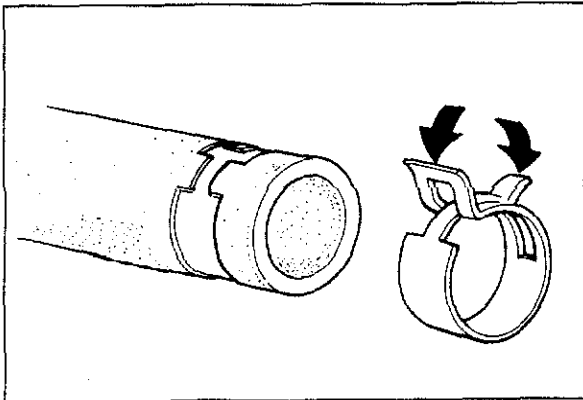

83U01A-046

## Hose Clamp

1. Position the hose clamp in the original location on the hose.
2. Squeeze the clamp lightly with large pliers to ensure a good fit.

**Engine Mount Torque Specification**

After installing the engine into the engine room, tighten the engine mount bolts to the specified torque.

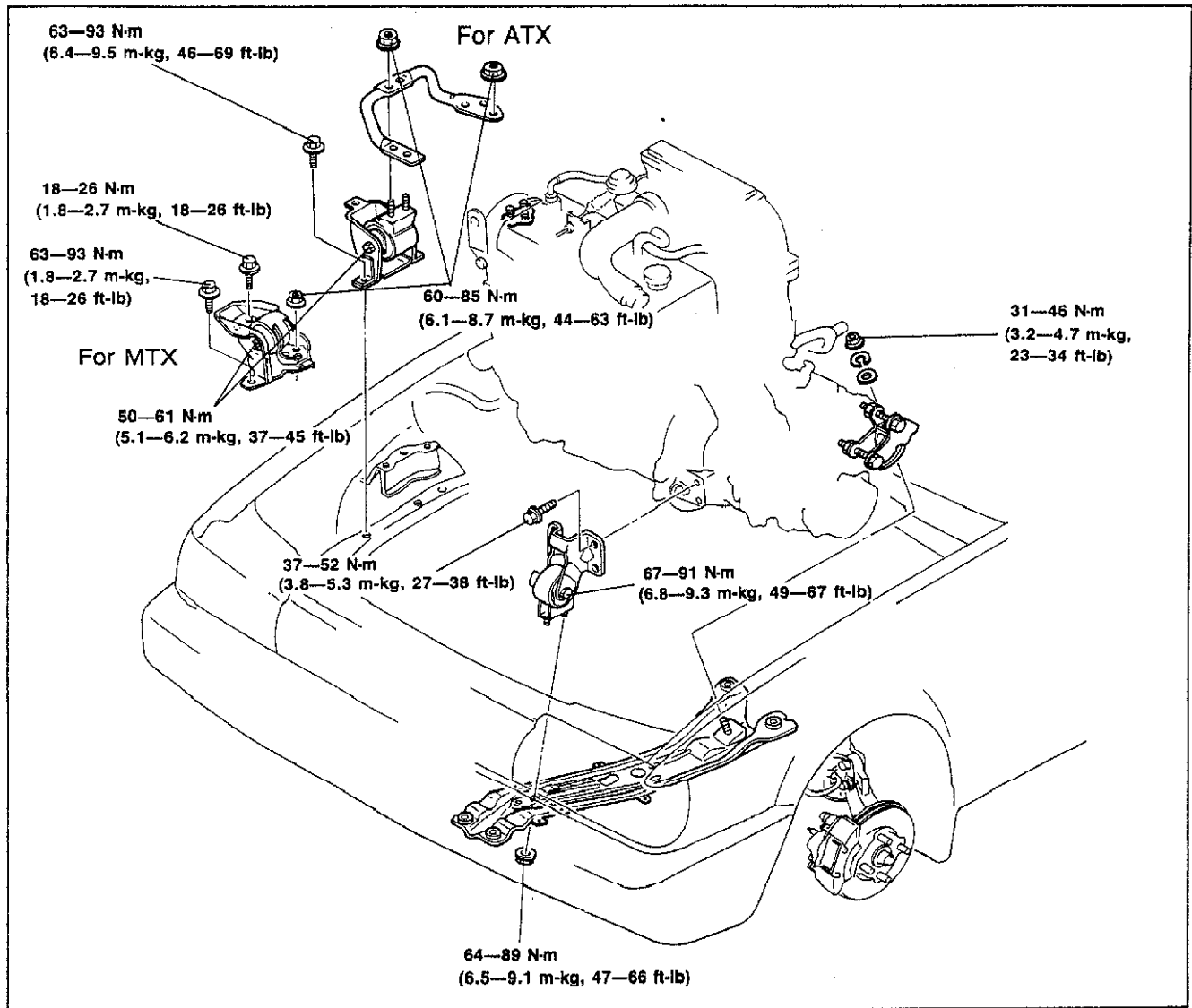

83U01A-047

**Steps After Installation**

1. Adjust the drive belt tension. (Refer to 1A—6)
2. Fill the radiator and sub tank with coolant.
3. Fill the engine with engine oil.
4. Fill the transaxle with transaxle oil.

**Check Engine Condition**

1. Check for leaks.
2. Perform engine adjustment as necessary.
3. Perform a road test.
4. Recheck the oil and coolant levels.

83U01A-048

## DISASSEMBLY

### Disassembly Note

1. Care should be taken during the disassembly of any part or system to study its order of assembly. Any deformation, wear, or damage also should be noted.
2. Code all identical parts (such as pistons, piston rings, connecting rods, and valve springs) so that they can be reinstalled in the position from which they were removed.
3. After steam cleaning the parts, use compressed air to blow off any remaining water.
4. Remove the parts in the order shown in the figure.

### Disassembly of Engine Auxillary Parts

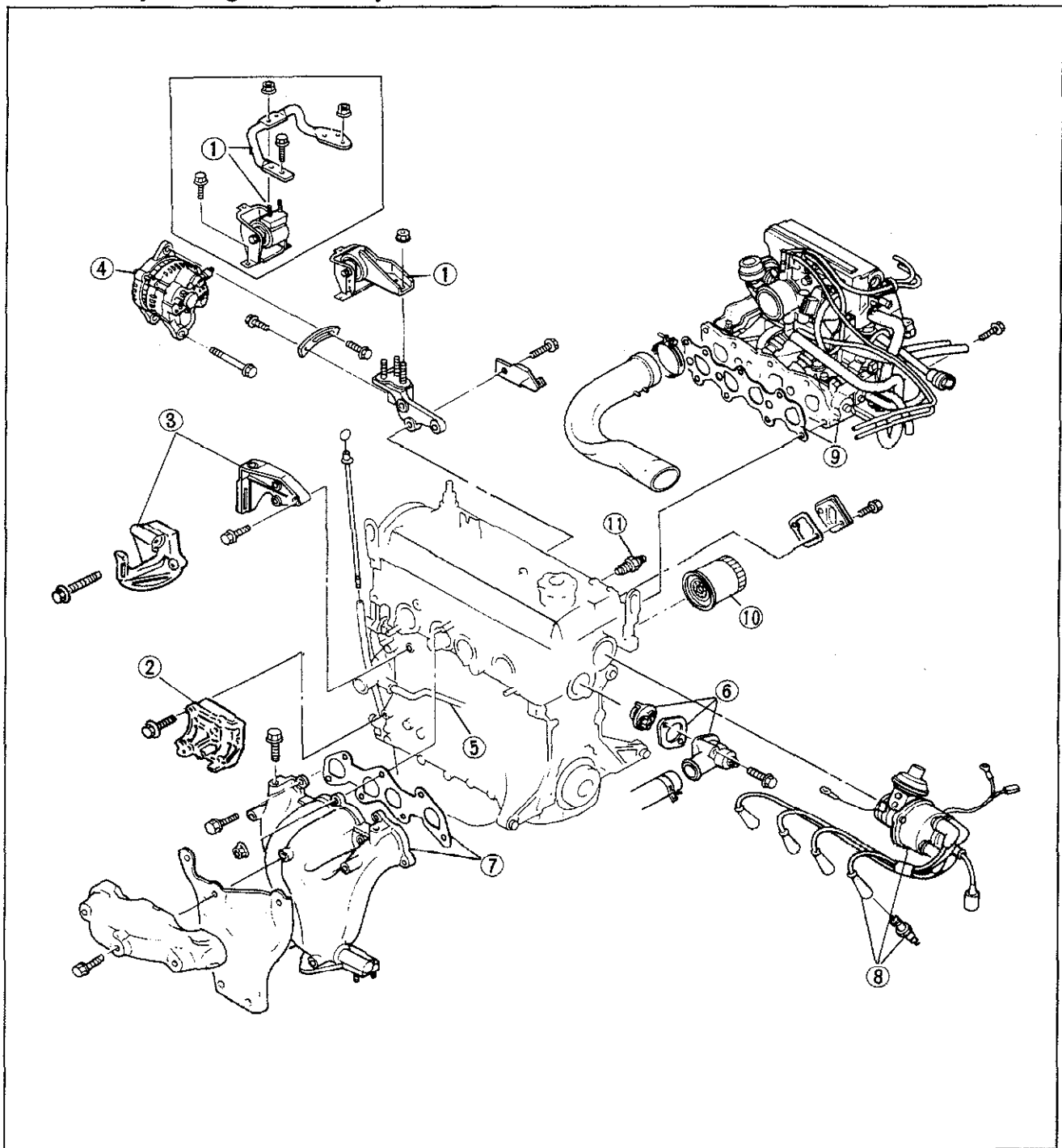

63U01X-056

1. Engine mount and engine bracket
2. A/C compressor bracket
3. P/S pump bracket
4. Alternator
5. Coolant bypass pipe and hose
6. Thermostat cover and thermostat
7. Exhaust manifold and gasket
8. High-tension leads, spark plugs and distributor
9. Intake manifold assembly and gasket
10. Oil filter
11. Oil pressure switch

83U01A-049

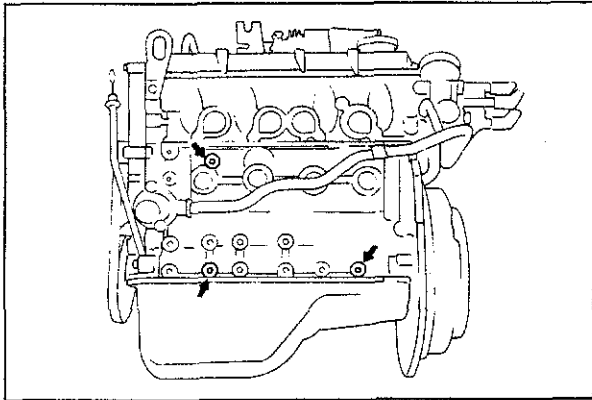

83U01X-142

### Engine hanger

After removing the exhaust manifold, install the engine on the **SST**.

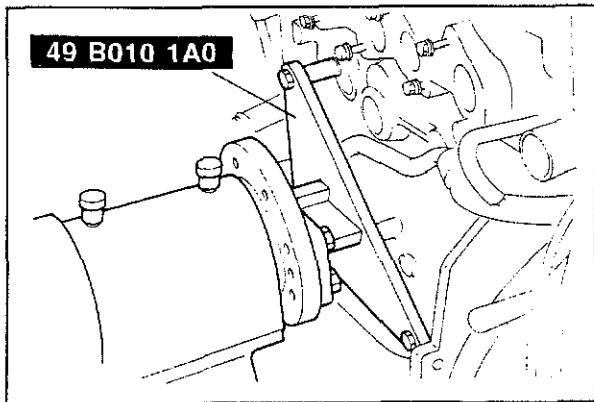

83U01A-050

# 1A DISASSEMBLY

## Disassembly of front of Engine

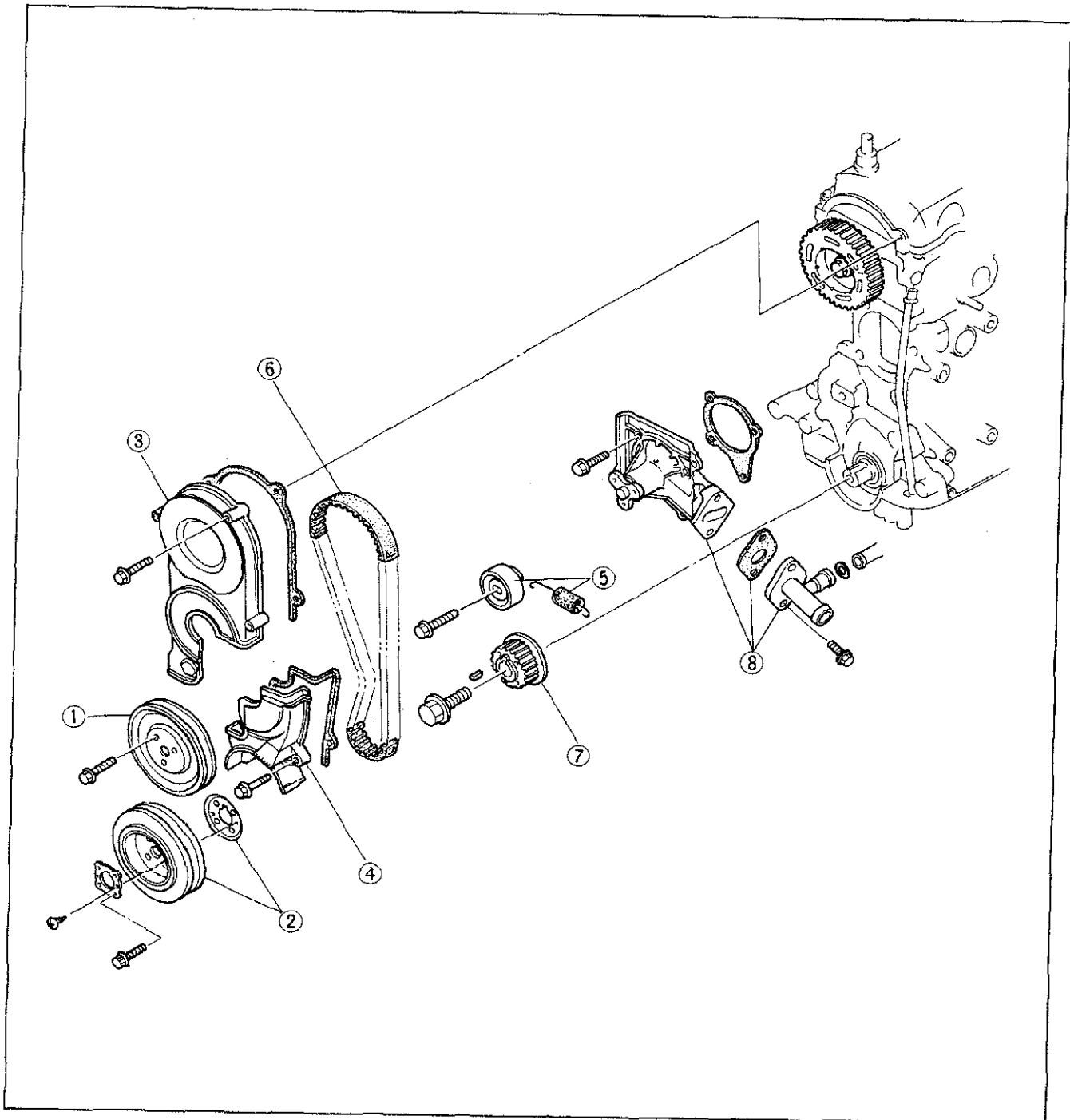

83U01A-051

1. Waterpump pulley
2. Crankshaft pulley and baffle plate
3. Upper timing belt cover
4. Lower timing belt cover

5. Timing belt tensioner and spring
6. Timing belt
7. Timing belt pulley
8. Water pump and coolant inlet pipe

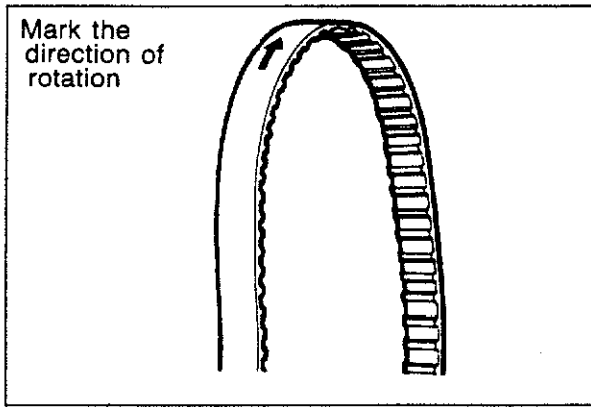
**Timing belt**

1. Remove the tensioner spring after loosening the tensioner lock bolt.
2. Mark the direction of rotation on the timing belt.
3. Remove the timing belt.

**Caution**

**Do not allow any oil or grease on the timing belt.**

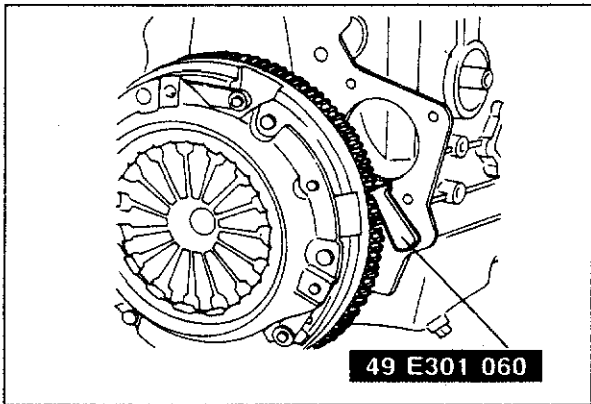
**Crankshaft pulley and timing belt pulley**

Set the **SST** to the flywheel. Remove the crankshaft pulley and the timing belt pulley.



# 1A DISASSEMBLY

## Disassembly Related to Cylinder Head

### Note

During disassembly, inspect the camshaft end play, camshaft bearing oil clearance referring to INSPECTION AND REPAIR section

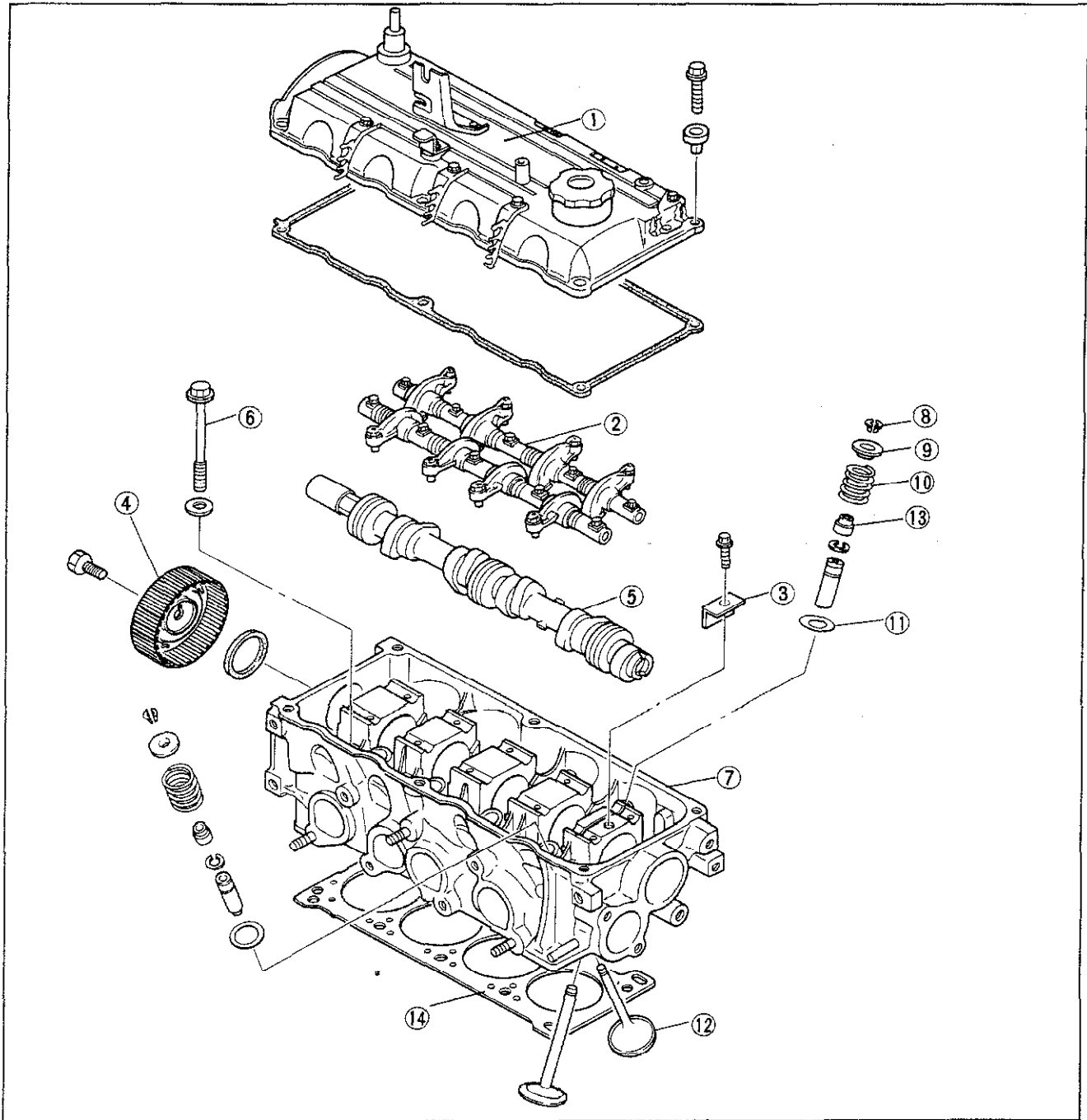

83U01A-052

- |   |                          |
|---|--------------------------|
| 1. Cylinder head cover                  | 8. Spring retainers      |
| 2. Rocker arm and rocker shaft assembly | 9. Upper spring seats    |
| 3. Thrust plate                         | 10. Valve springs        |
| 4. Camshaft pulley                      | 11. Lower spring seats   |
| 5. Camshaft                             | 12. Valves               |
| 6. Cylinder head bolts                  | 13. Valve seals          |
| 7. Cylinder head                        | 14. Cylinder head gasket |

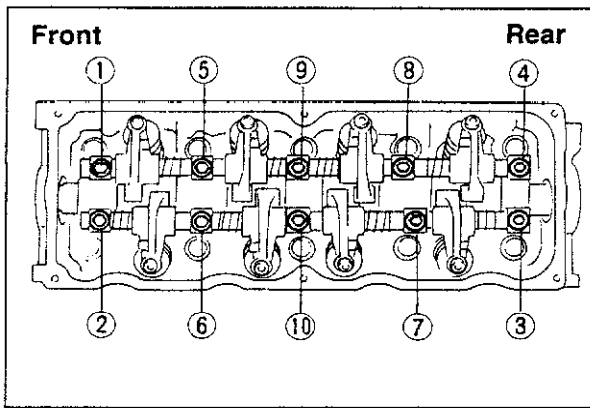

4BG01A-095

### Rocker arm and rocker shaft assembly

1. Loosen the bolts gradually in the sequence shown in the figure.
2. Remove the rocker arm and rocker shaft assembly with bolts.

### Caution

**Do not mix up the various parts of the rocker arm and rocker shaft assembly.**

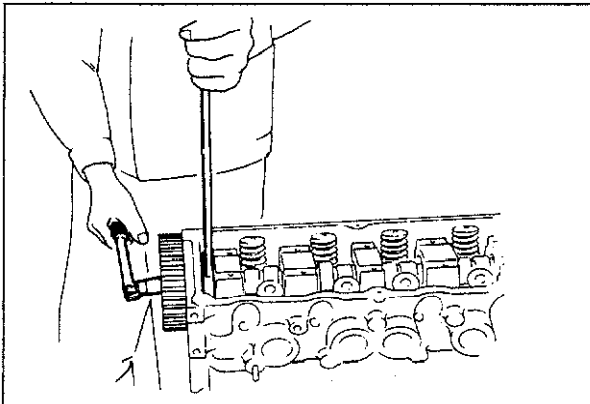

83U01A-053

### Camshaft pulley

1. Hold the camshaft using a suitable wrench on the cast hexagon.
2. Remove the camshaft pulley.

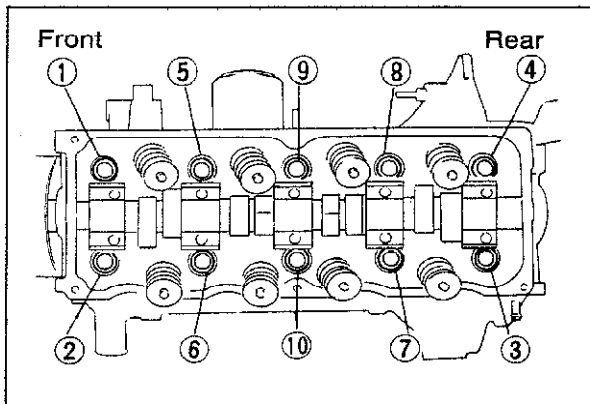

4BG01A-096

### Cylinder head bolt

Remove the cylinder head bolts in the numbered order shown in the figure. Loosen them gradually, in order.

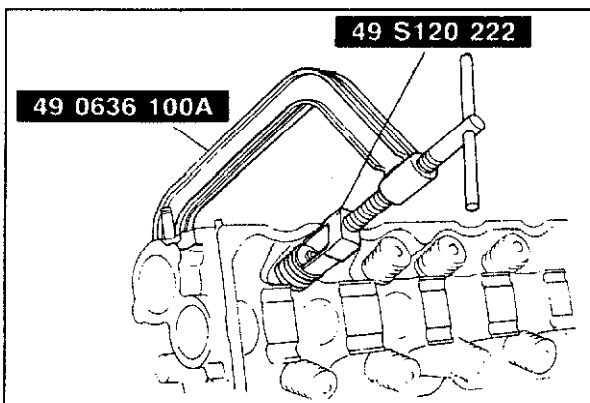

83U01B-042

### Valve

Remove the valves from the cylinder head with the SST.

# 1A DISASSEMBLY

## Disassembly Related to Lubrication System and Flywheel

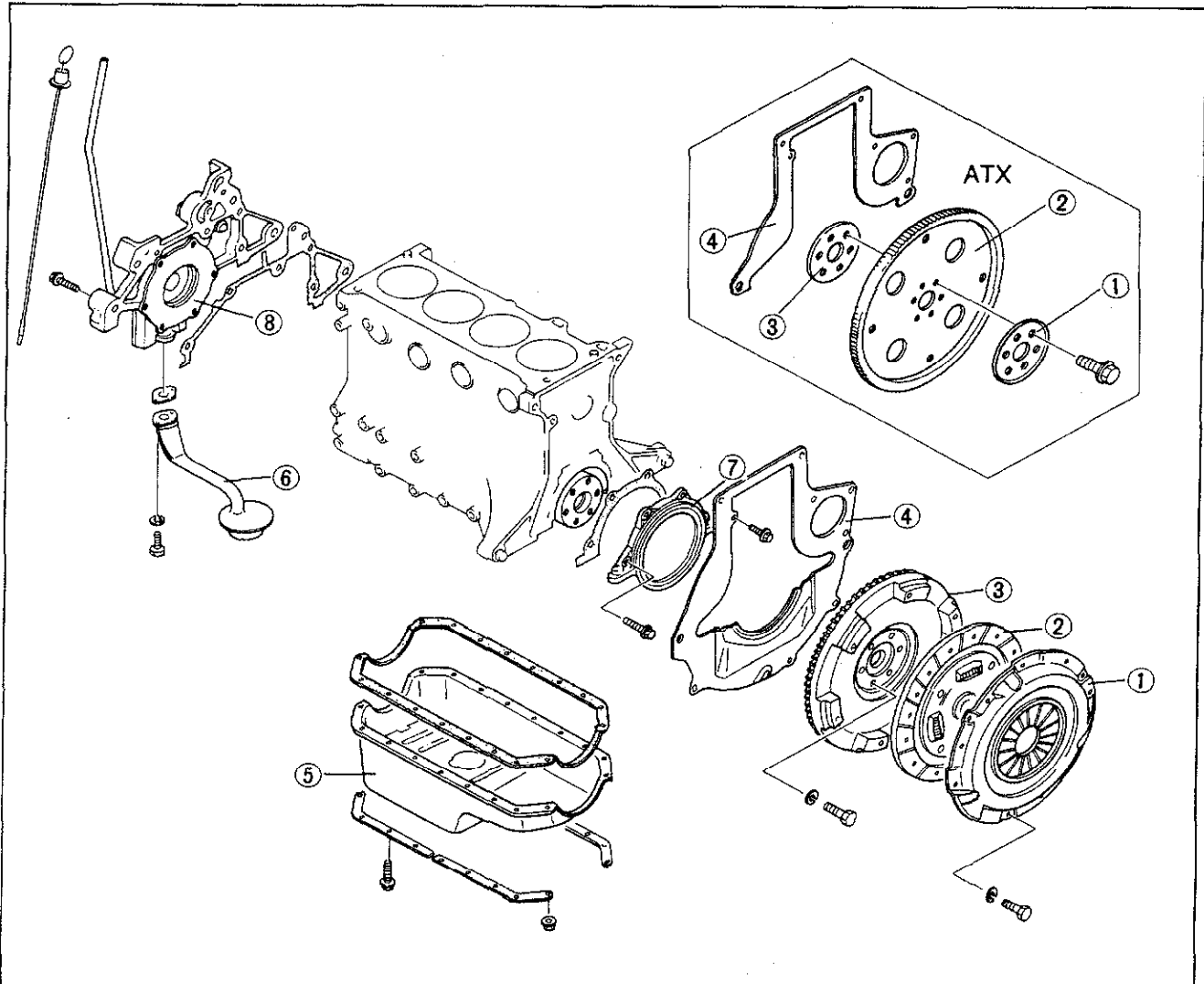

83U01A-054

1. Clutch cover (MTX), Backing plate (ATX)
2. Clutch disc (MTX), Drive plate (ATX)
3. Flywheel (MTX), Adaptor (ATX)
4. End plate

5. Oil pan
6. Oil strainer
7. Rear cover
8. Oil pump

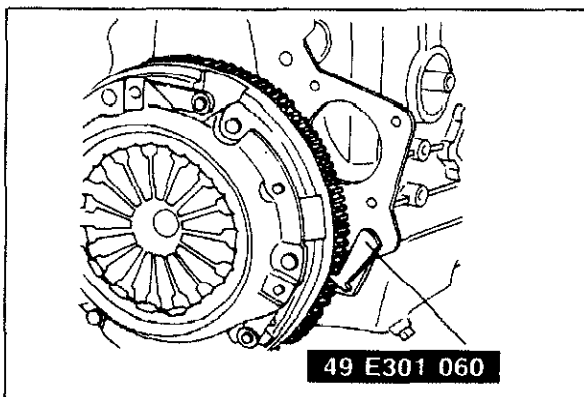

83U01X-144

### Clutch cover and flywheel

Remove the clutch cover and flywheel with the **SST** as shown in the figure.

## Disassembly Related to Crankshaft and Piston

**Note**

During disassembly, inspect the crankshaft end play, main journal bearing oil clearance, connecting rod bearing oil clearance, connecting rod side clearance referring to ASSEMBLY section.

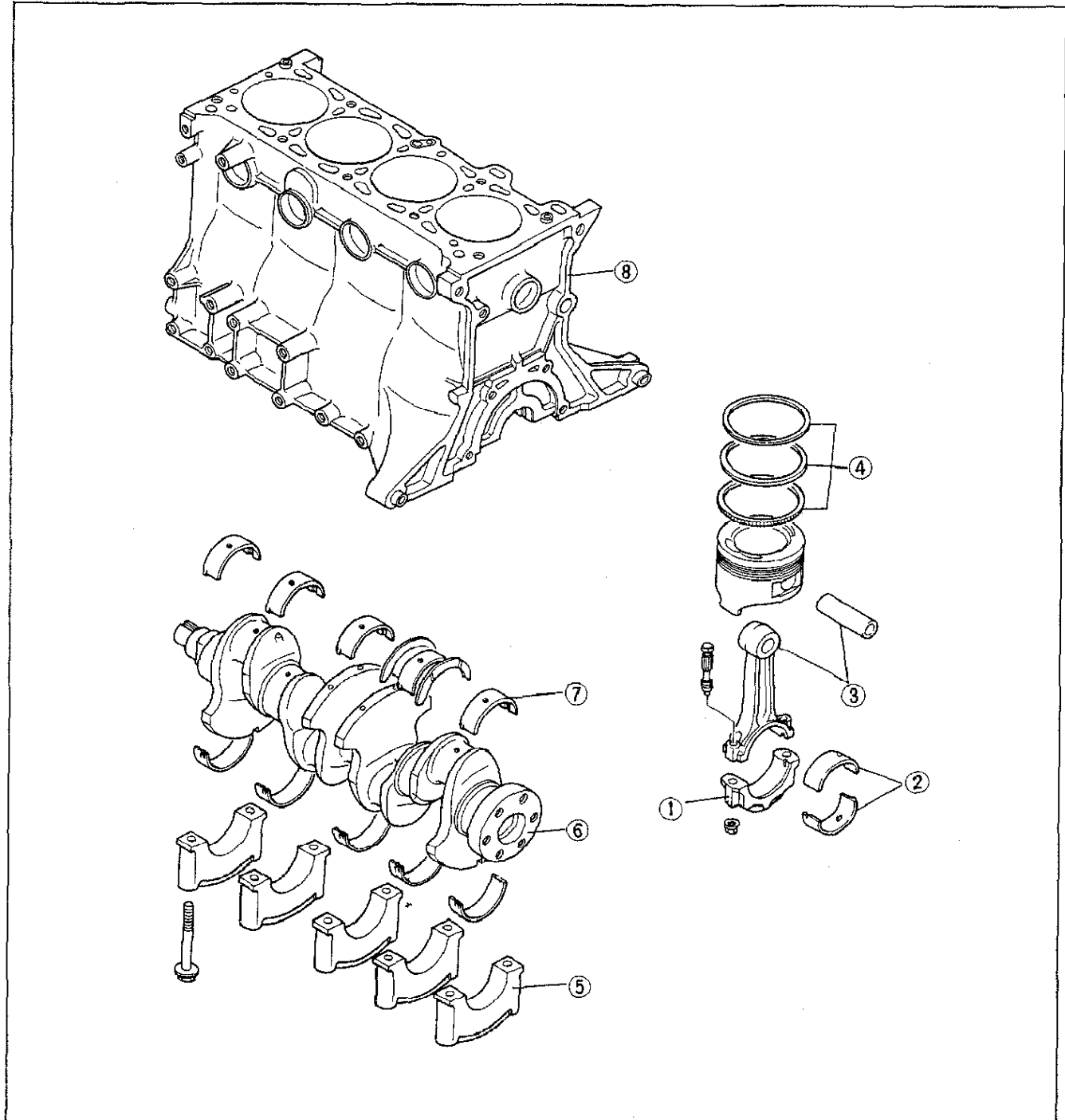

83U01A-055

1. Connecting rod caps
2. Connecting rod bearings
3. Connecting rod and piston pin
4. Piston rings

5. Main bearing caps
6. Crankshaft
7. Main bearings
8. Cylinder block

# 1A DISASSEMBLY

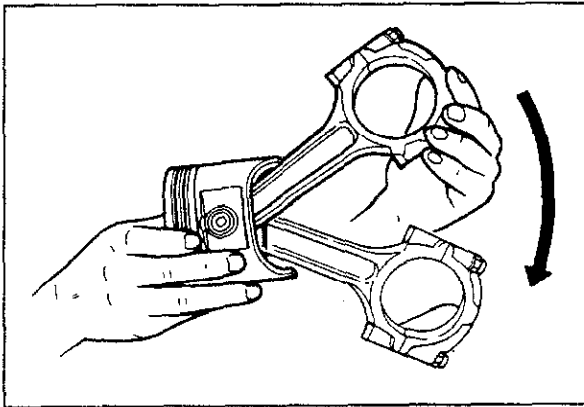

83U01A-056

## Piston and connecting rod

1. Check the oscillation torque of the connecting rod as shown in the figure. If the large end does not drop by its own weight, replace the piston and/or piston pin.

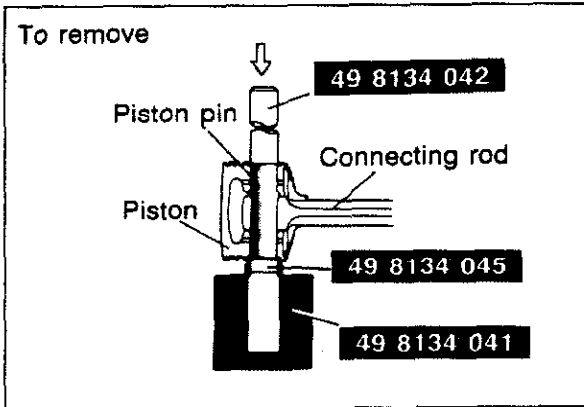

83U01A-057

2. Remove the piston pin with the **SST** as shown.

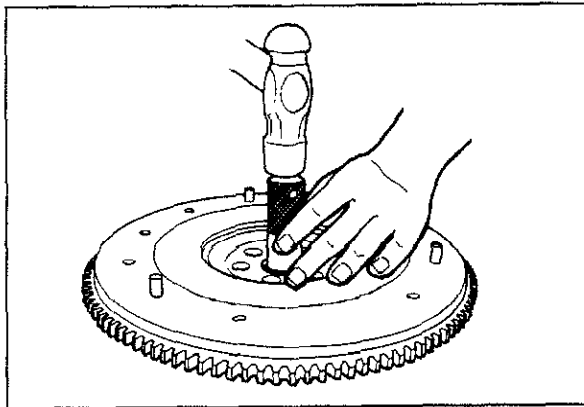

63U01X-065

## Flywheel pilot bearing

Use suitable pipe and punch out to the crankshaft side of the flywheel, as shown in the figure.

**INSPECTION AND REPAIR**

1. Clean all parts, taking care to remove any gasket fragments, dirt, oil or grease, carbon, moisture residue, or other foreign material.
2. Inspect and repair in the order specified.

**Caution**

**Be careful not to damage the joints or friction surfaces of aluminum alloy components such as the cylinder head or pistons.**

83U01A-058

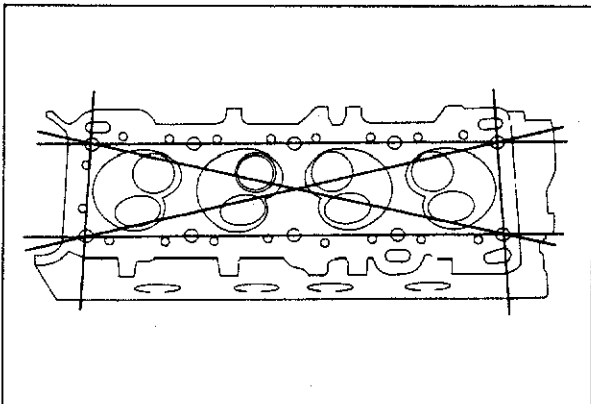

83U01A-059

**Cylinder Head**

1. Inspect the cylinder head for damage, cracks, and leakage of water or oil, replace if necessary.
2. Measure the cylinder head distortion in the six directions shown in the figure.

**Distortion: 0.15 mm (0.006 in) max.**

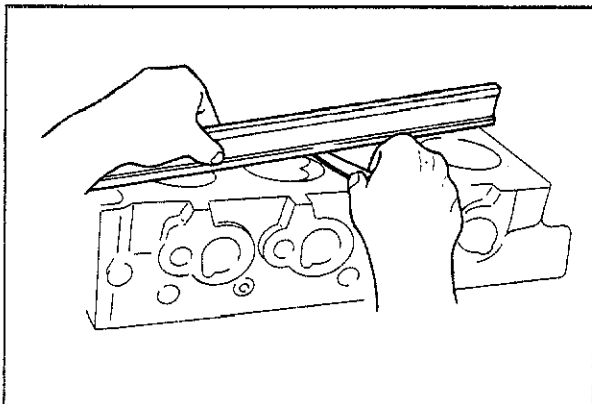

83U01A-060

3. If the cylinder head distortion exceeds specification, grind the cylinder head surface. If the cylinder head height is not within specification, replace it.

**Height:**

**107.4—107.6 mm (4.228—4.236 in)**

**Grinding: 0.20 mm (0.008 in) max.**

**Note**

**Before grinding the cylinder head, first check the following and replace the head if necessary.**

- Sinking of valve seat
- Distortion of manifold contact surface
- Camshaft oil clearance and end play

4. Measure the manifold contact surface distortion in the six directions shown in the figure.

**Distortion: 0.15 mm (0.006 in) max.**

5. If distortion exceeds specification, grind the surface or replace the cylinder head.

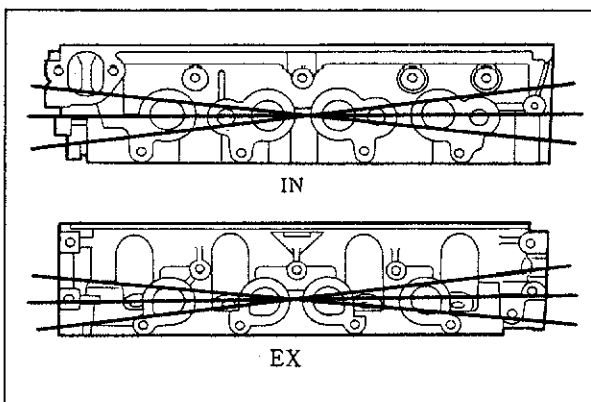

83U01A-061

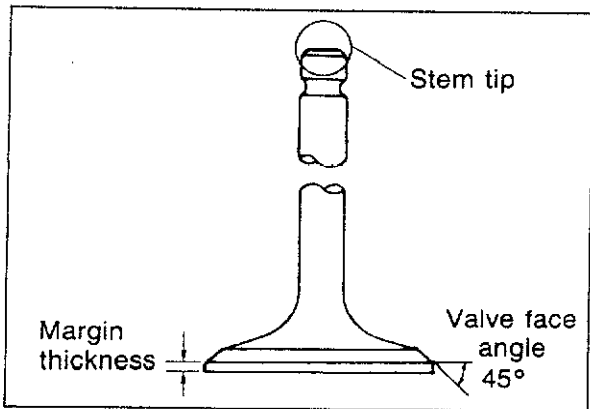

69G01B-090

## Valve and Valve Guide

1. Inspect each valve for the following, replace or resurface as necessary.
  - (1) Damaged or bent stem
  - (2) Roughness or damage to the face
  - (3) Damage or uneven wear of the stem tip
2. Check the valve head margin thickness, replace if necessary

### Margin thickness

IN : 0.5 mm (0.020 in) min.

EX : 1.0 mm (0.039 in) min.

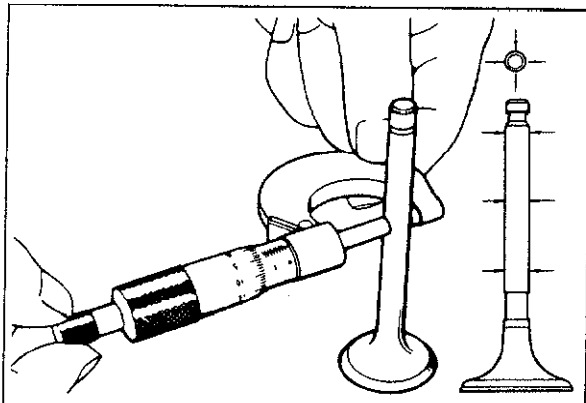

83U01A-062

3. Measure the valve length.

### Length

IN : 103.77 mm (4.0854 in)

EX : 102.67 mm (4.0421 in)

4. Measure the valve stem diameter.

### Diameter

IN : 6.970—6.985 mm (0.2744—0.2750 in)

EX : 6.965—6.980 mm (0.2742—0.2748 in)

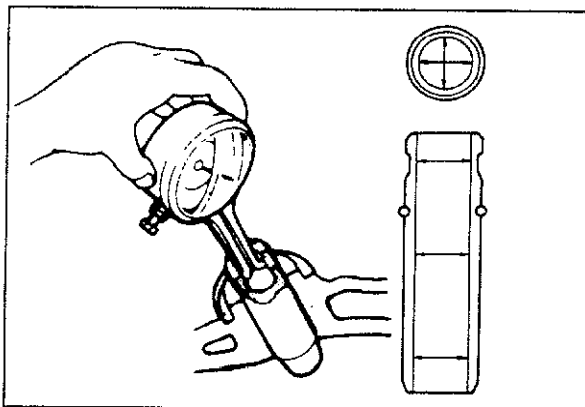

83U01A-063

5. Measure the valve guide inner diameter.

### Inner diameter

IN : 7.01—7.03 mm (0.2760—0.2768 in)

EX : 7.01—7.03 mm (0.2760—0.2768 in)

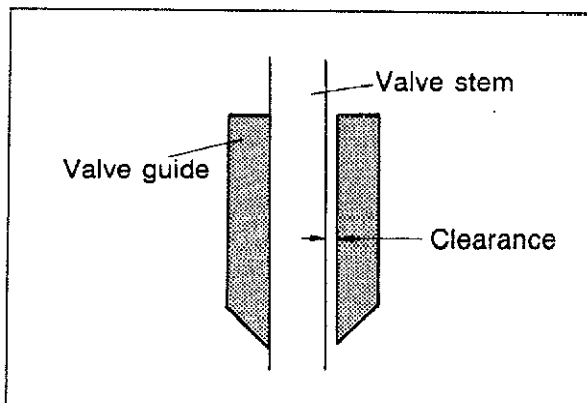

83U01A-064

6. Measure the valve stem to guide clearance.

(1) Method No. 1

Subtract the valve stem measurement from the corresponding valve guide inner diameter measurement.

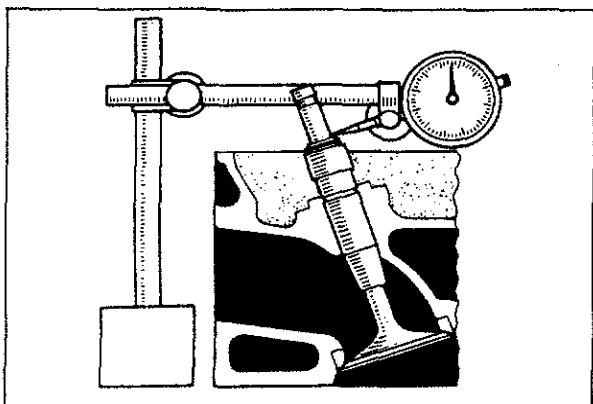

83U01A-065

- (2) Method No. 2  
Measure the valve stem play at a point close to the valve guide with the valve lifted off the valve seat.

### Clearance

**IN : 0.025—0.060 mm (0.0010—0.0024 in)**  
**EX: 0.030—0.065 mm (0.0012—0.0026 in)**  
**Maximum: 0.20 mm (0.0079 in)**

7. If the clearance exceeds the maximum, replace the valve and/or valve guide.

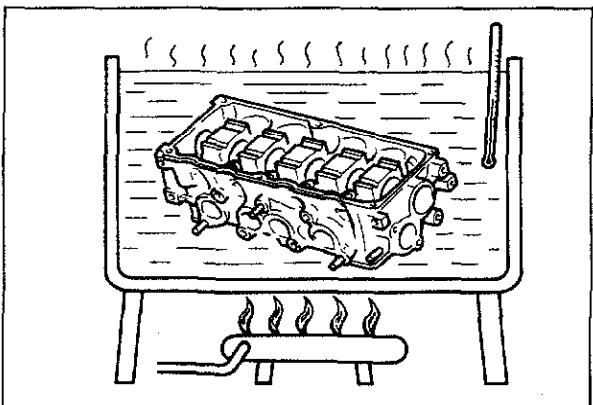

69G01B-093

### Replacement of valve guide

#### Removal

1. Gradually heat the cylinder head in water to approx. **90°C (190°F)**.

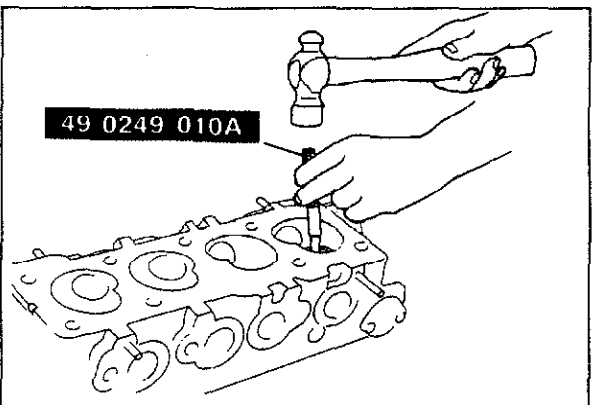

83U01A-066

2. Remove the valve guide from the side opposite the combustion chamber with the **SST**.  
 3. Remove the valve guide clip

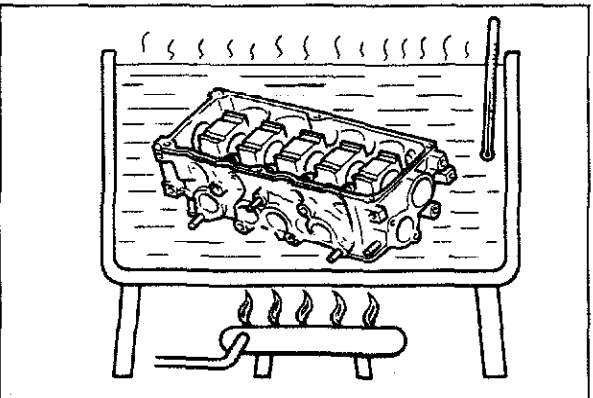

83U01A-135

#### Installation

1. Fit the clip onto the valve guide.  
 2. Gradually heat the cylinder head in water to approx. **90°C (190°F)**.  
 3. Tap the valve guide in from the side opposite the combustion chamber until the clip contacts the cylinder head with the **SST** (49 0249 010A).



# 1A INSPECTION AND REPAIR

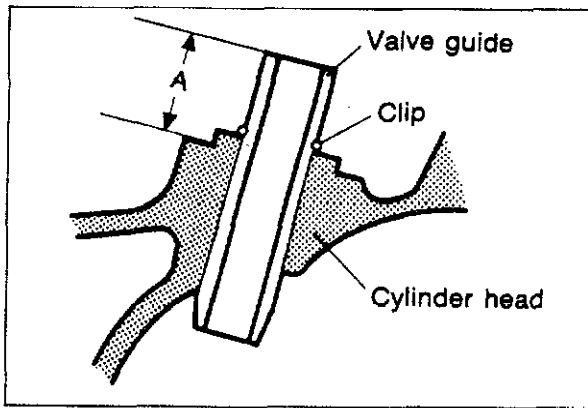

83U01A-067

4. Check that the protrusion height (dimension A in the figure) is within specification.

### Height:

13.2—13.8 mm (0.520—0.543 in)

### Note

Although the shapes of the intake and exhaust valve guides are different, use the exhaust valve guide on both sides as a replacement.

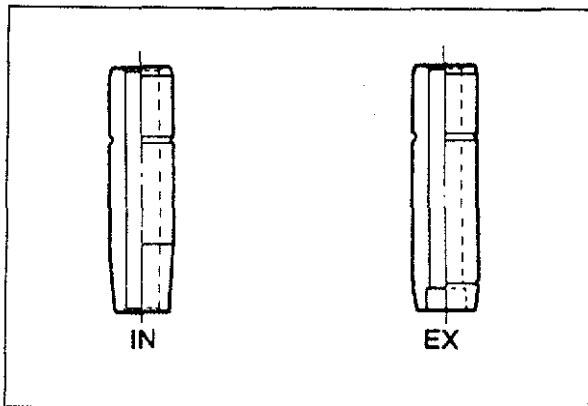

69G01B-098

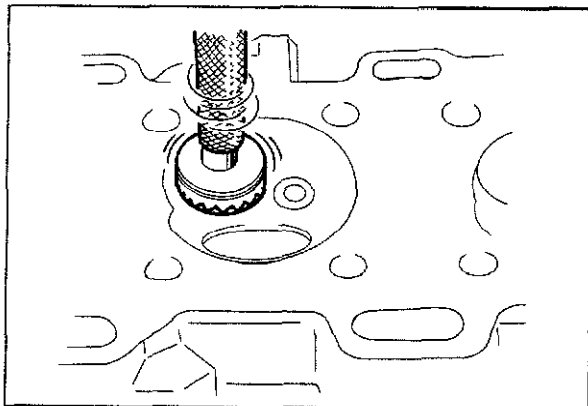

### Valve Seat

1. Inspect the contact surface of the valve seat and valve face.
  - (1) Roughness
  - (2) Damage
2. If necessary, resurface the valve seat using a **45°** valve seat cutter and/or resurface the valve face.

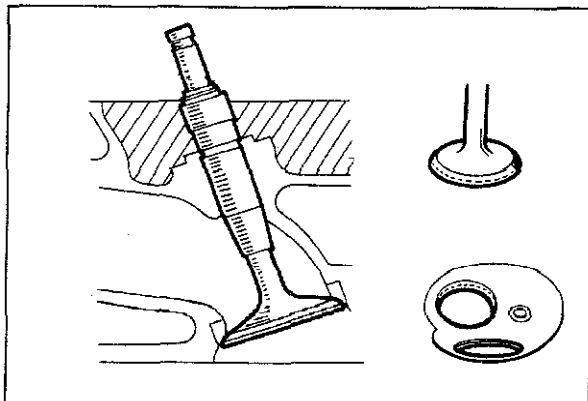

3. Apply a thin coat of prussian blue to the valve face.
4. Check the valve seating by pressing the valve against the seat.
  - (1) If blue does not appear 360° around the valve face, replace the valve.
  - (2) If blue does not appear 360° around the valve seat, resurface the seat.

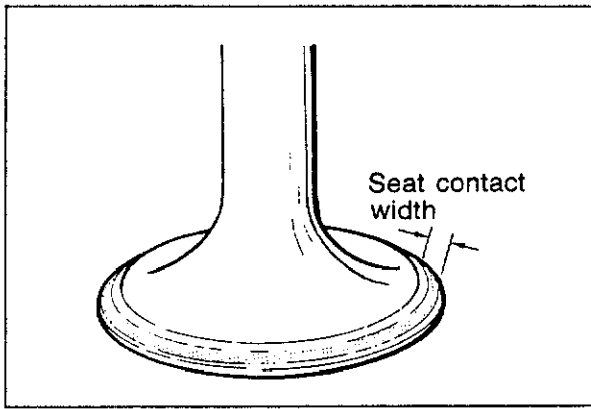

83U01A-069

5. Check the seat contact width and valve seating position on the valve face.

**Width:**

**1.1—1.7 mm (0.043—0.067 in)**

6. Check that the valve seating position is at the center of the valve face.

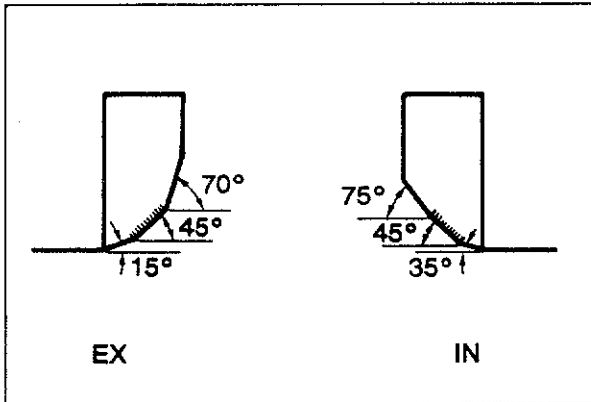

83U01A-070

- (1) If the seating position is too high, correct the valve seat using a **75°** cutter, and a **45°** cutter.
- (2) If the seating position is too low, correct the valve seat using a **35° (IN)** or **15° (EX)**, and a **45°** cutter.

7. Seat the valve to the valve seat using a lapping compound.

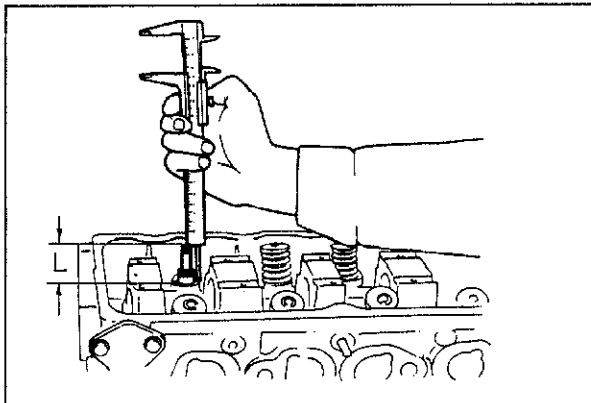

83U01A-071

8. Check the sinking of the valve seat. Measure protruding length (dimension "L") of the valve stem.

**Dimension "L": 39.0 mm (1.535 in)**

- (1) If "L" is as below, it can be used as it is.

**39.0—39.5 mm (1.535—1.555 in)**

- (2) If "L" is as below, insert a spacer between the spring seat and cylinder head so that "L" will be as specified.

**39.5—40.5 mm (1.555—1.594 in)**

- (3) If "L" is more than as below, replace the cylinder head.

**40.5 mm (1.594 in) or more**

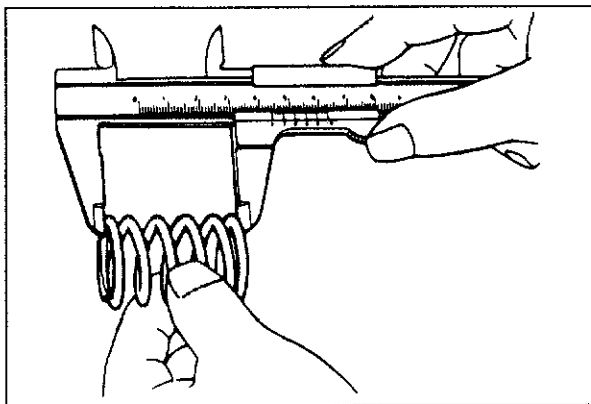

83U01A-072

**Valve Spring**

1. Inspect each valve spring for cracks or damage.
2. Check the free length and angle, replace if necessary.

**Free length**

**Standard: 43.7 mm (1.720 in)**

**Minimum: 42.3 mm (1.665 in)**

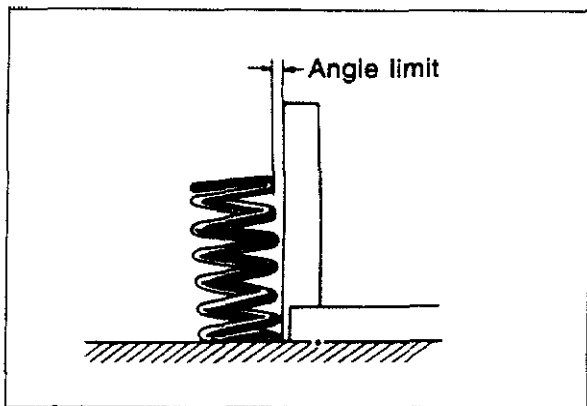

83U01A-073

**Angle: 1.5 mm (0.059 in) max.**

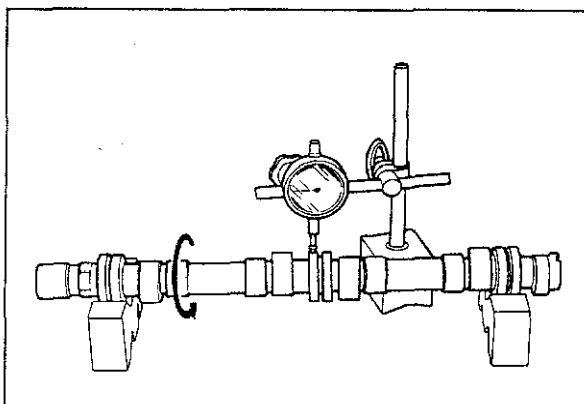

83U01A-074

### Camshaft

1. Set the front and rear journals on V-blocks. Check the camshaft runout, replace if necessary.

**Runout: 0.03 mm (0.0012 in) max.**

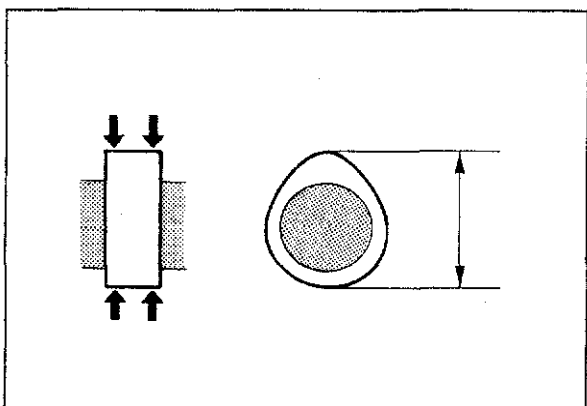

83U01A-075

2. Check the cam for wear or damage, replace if necessary.
3. Check the cam lobe height at the two places as shown.

### Height

**IN : 36.38—36.53 mm (1.432—1.438 in)**

**EX : 36.38—36.53 mm (1.432—1.438 in)**

### Minimum

**IN : 36.23 mm (1.426 in)**

**EX : 36.23 mm (1.426 in)**

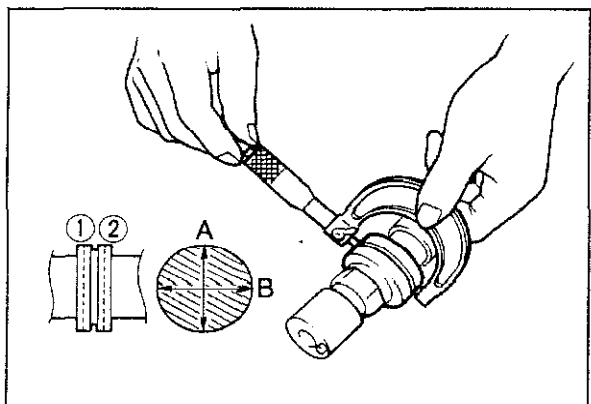

83U01A-076

4. Measure wear of the journals in X and Y directions at the two places shown.

### Diameter

#### Front and rear:

**43.440—43.465 mm (1.7102—1.7112 in)**

#### Center:

**43.410—43.435 mm (1.7091—1.7100 in)**

**Out-of-round: 0.05 mm (0.002 in) max.**

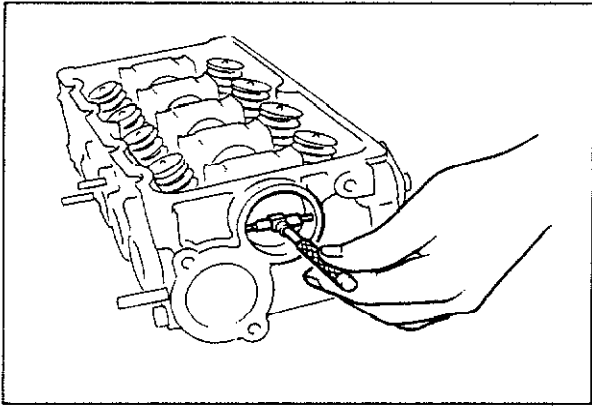

83U01A-077

5. Measure the oil clearances between the camshaft and cylinder head.
  - (1) Remove any oil or dirt from the journals and the camshaft bore.
  - (2) Measure the camshaft bore diameter.

**Diameter:**

**43.500—43.525 mm (1.7126—1.7135 in)**

- (3) Subtract the journal diameter from the bore diameter.

**Oil clearance**

**Front and Rear**

**0.035—0.085 mm (0.0013—0.0033 in)**

**Center:**

**0.065—0.115 mm (0.0026—0.0045 in)**

**Maximum: 0.15 mm (0.0059 in)**

- (4) If the clearance exceeds the maximum, replace the camshaft or cylinder head.

83U01A-078

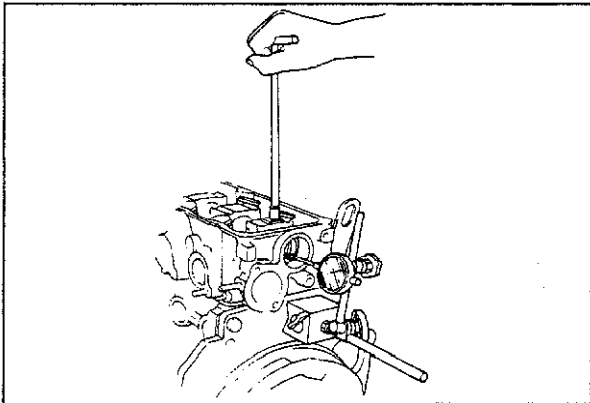

83U01A-079

6. Measure the camshaft end play. If it exceeds the maximum, replace the thrust plate or camshaft.

**End play:**

**0.05—0.18 mm (0.0020—0.0071 in)**

**Maximum: 0.20 mm (0.0079 in)**

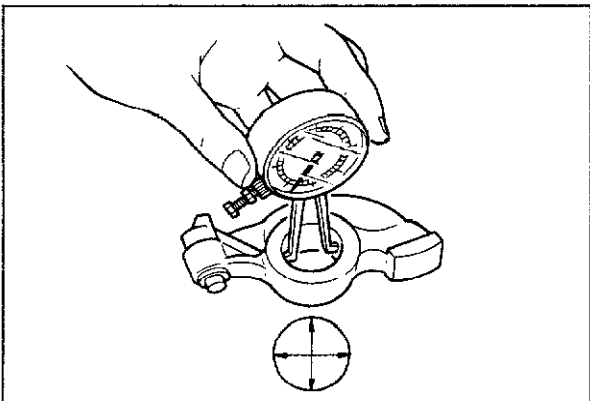

83U01A-080

**Rocker Arm and Rocker Arm Shaft**

1. Check for wear or damage to the contact surface of the rocker arm shaft or the rocker arm. Replace if necessary.
2. Check the oil clearance between the rocker arm and shaft, replace if necessary.
  - (1) Measure the rocker arm inner diameter.

**Diameter:**

**18.000—18.027 mm (0.7087—0.7097 in)**

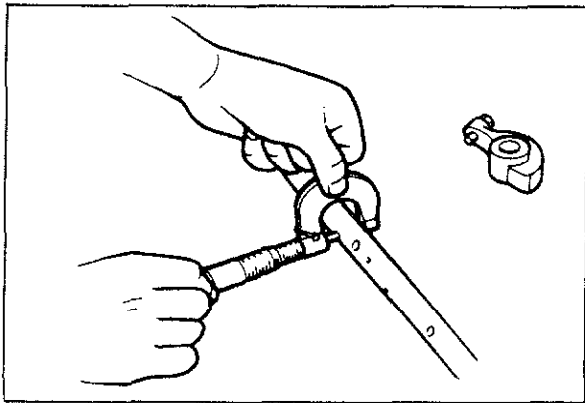

83U01A-081

- (2) Measure the rocker arm shaft diameter.

**Diameter:**

**17.959—17.980 mm (0.7070—0.7078 in)**

- (3) Subtract the shaft diameter from the rocker arm diameter.

**Oil clearance:**

**0.020—0.068 mm (0.0008—0.0027 in)**

**Maximum: 0.10 mm (0.0039 in)**

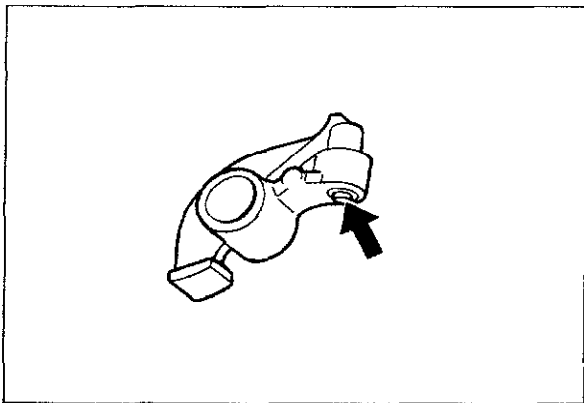

69G01A-116

**Hydraulic Lash Adjuster (HLA)**

Check the HLA face for wear or damage, replace if necessary.

**Caution**

**Do not remove the HLA unless necessary to prevent damage to the "O" ring.**

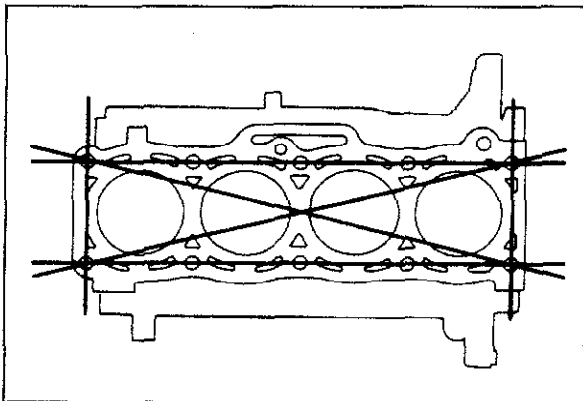

69G01A-117

**Cylinder Block**

1. Check the cylinder block, repair or replace if necessary.
  - (1) Leakage damage
  - (2) Cracks
  - (3) Scoring of wall
2. Measure the distortion of the top surface of the cylinder block in the six directions shown in figure.

**Distortion: 0.15 mm (0.006 in) max.**

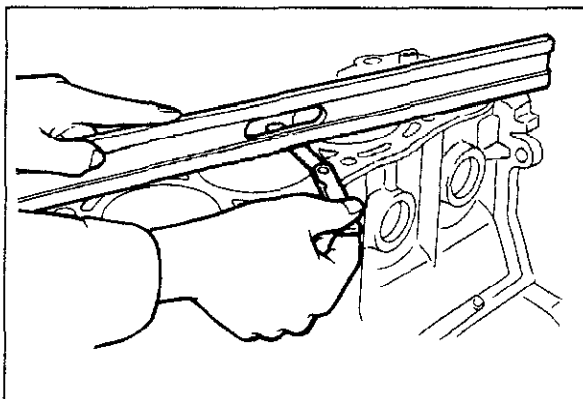

69G01A-118

3. If the distortion exceeds the maximum, repair by grinding, or replace the cylinder block.

**Grinding: 0.20 mm (0.008 in) max.**

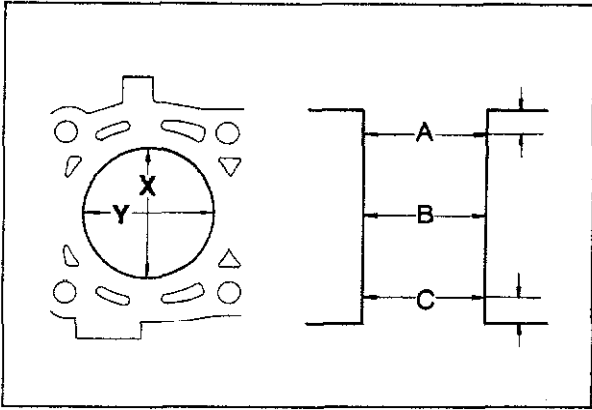

83U01A-082

4. Measure the cylinder bore in directions X and Y at three levels in each cylinder as shown.

**Cylinder bore** mm (in)

Size	Bore
Standard	78.000—78.019 (3.0709—3.0717)
0.25 (0.010) oversize	78.250—78.269 (3.0807—3.0815)
0.50 (0.020) oversize	78.500—78.519 (3.0905—3.0913)

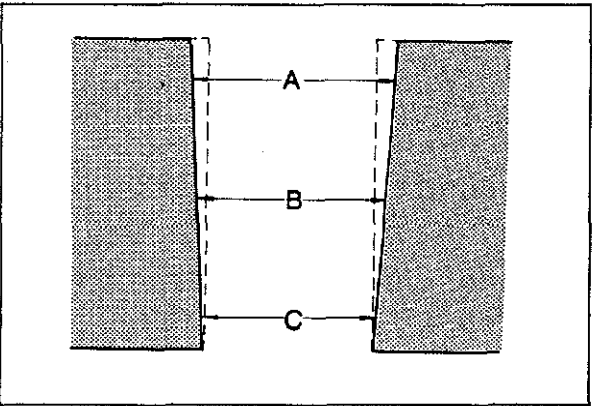

83U01A-083

(1) If the difference between the measurement A and C exceeds the maximum taper, rebore the cylinder to oversize.

**Taper: 0.019 mm (0.0007 in) max.**

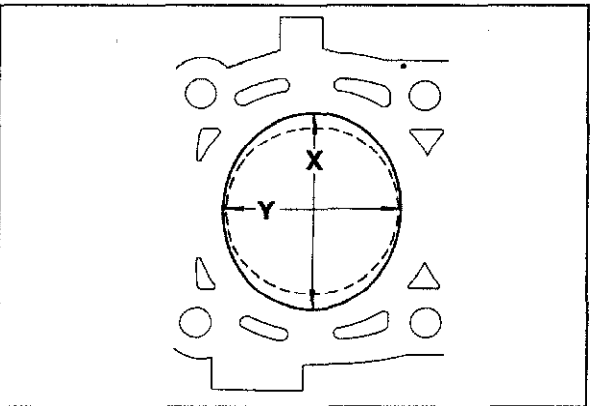

83U01A-084

(2) If the difference between the measurement X and Y exceeds the maximum out-of-round, rebore the cylinder to oversize.

**Out-of-round: 0.019 mm (0.0007 in) max.**

**Caution**  
The boring size should be the same for all cylinders.

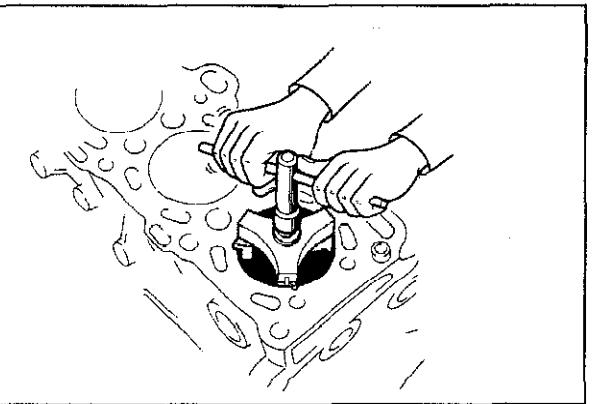

69G01A-122

5. If the upper part of the cylinder wall shows uneven wear, remove the ridge using a ridge reamer.

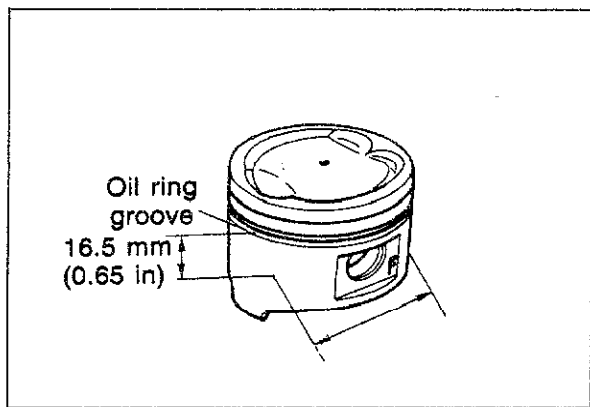

83U01A-085

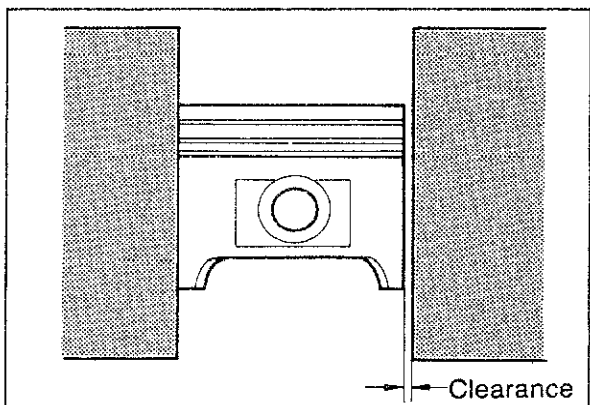

83U01A-086

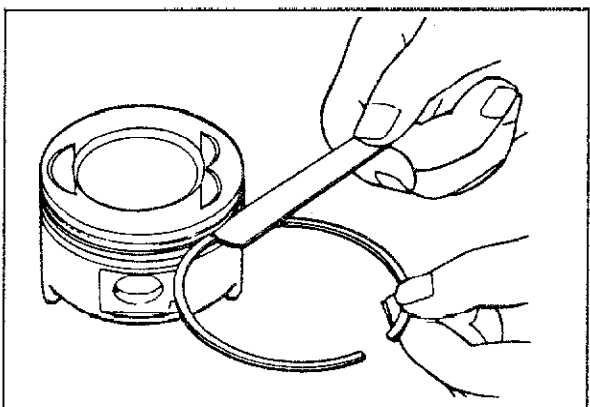

83U01A-087

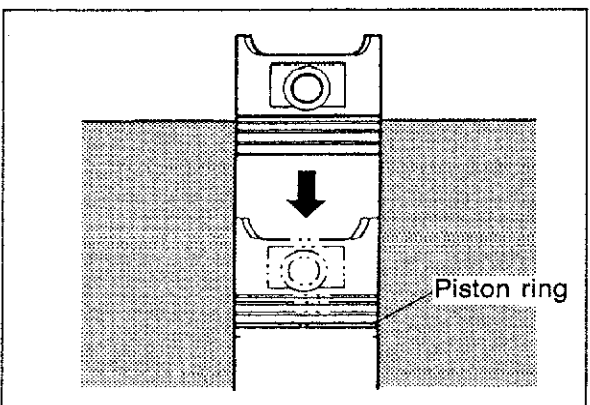

83U01A-088

## Piston

1. Inspect the outer circumferences of all pistons for seizure or scoring, replace if necessary.
2. Measure the outer diameter of each piston at a right angle ( $90^\circ$ ) to the piston pin, **16.5 mm (0.650 in)** below the oil ring land lower edge.

## Piston diameter

mm (in)

Size	Diameter
Standard	77.954—77.974 (3.0690—3.0698)
0.25 (0.010) oversize	78.204—78.224 (3.0789—3.0797)
0.50 (0.020) oversize	78.454—78.474 (3.0887—3.0895)

3. Check the piston to cylinder clearance.

### Clearance:

**0.026—0.065 mm (0.0010—0.0026 in)**

**Maximum: 0.15 mm (0.0059 in)**

4. If the clearance exceeds the maximum, replace the piston or rebore the cylinder to oversize.

### Note

**If the piston is replaced, replace the piston rings also.**

## Piston and Piston Ring

1. Measure the piston ring to ring land clearance around the entire circumference using a new piston ring.

### Clearance (Top and Second):

**0.030—0.065 mm (0.0012—0.0026 in)**

**Maximum: 0.15 mm (0.006 in)**

2. If the clearance exceeds the maximum, replace the piston.

3. Inspect the piston rings for damage, abnormal wear, or breakage, replace if necessary.

4. Insert the piston ring into the cylinder by hand and push it to the bottom of the ring travel in using the piston.

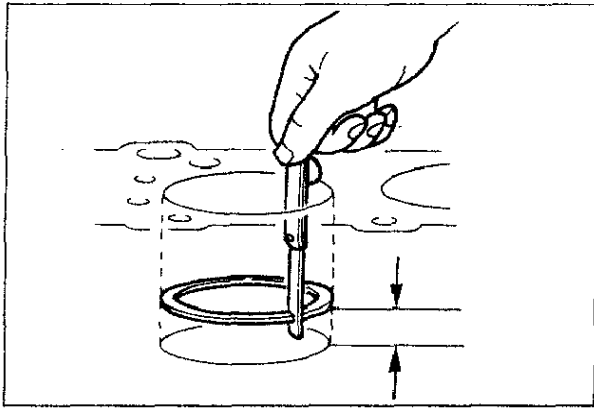

83U01A-089

5. Measure each piston ring end gap using a feeler gauge, replace if necessary.

### End gap

- Top : 0.20—0.40 mm (0.008—0.016 in)
- Second: 0.15—0.30 mm (0.006—0.012 in)
- Oil rail : 0.20—0.70 mm (0.008—0.028 in)
- Maximum: 1.0 mm (0.039 in)

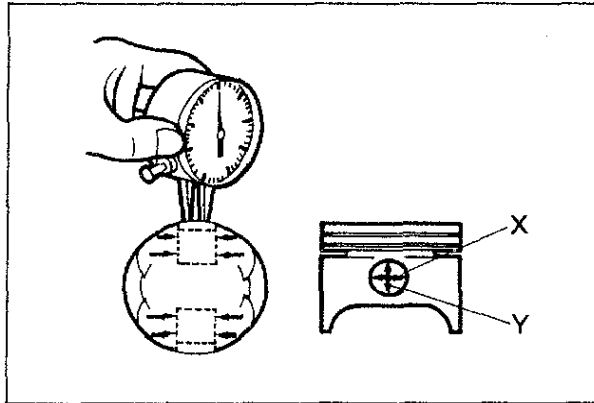

83U01A-090

### Piston and Piston Pin

1. Measure the piston pin hole diameter in X and Y directions at four places.

#### Diameter:

19.988—20.000 mm (0.7869—0.7874 in)

2. Measure the piston pin diameter in the same manner.

#### Diameter:

19.974—19.980 mm (0.7864—0.7866 in)

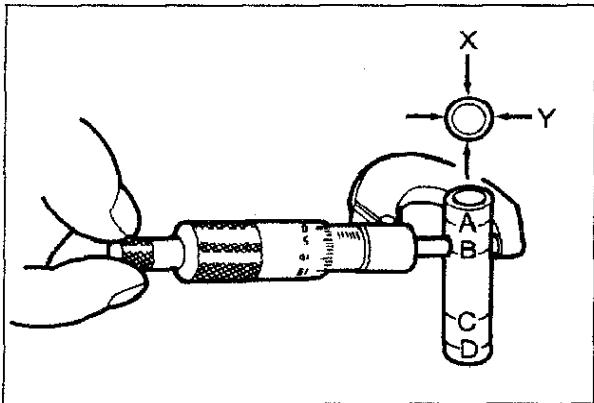

83U01A-091

3. Check the piston pin to piston clearance.

#### Clearance:

0.008—0.026 mm (0.0003—0.0010 in)

4. If the clearance exceeds the maximum, replace the piston and/or piston pin.

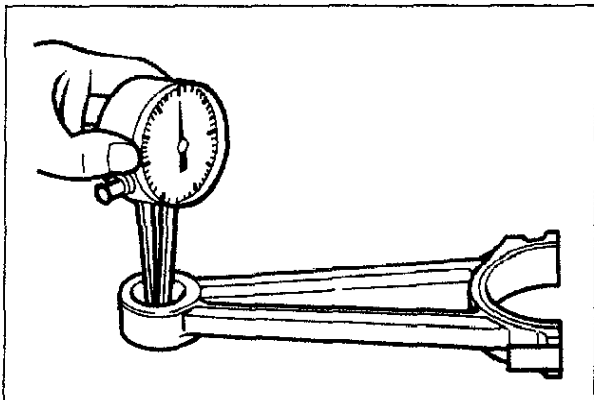

83U01A-092

### Connecting Rod

1. Measure the connecting rod small end bore.

#### Diameter:

19.948—19.961 mm (0.7854—0.7859 in)

2. Check the interference between the small end bore and piston pin.

#### Interference:

0.013—0.032 mm (0.0005—0.0013 in)



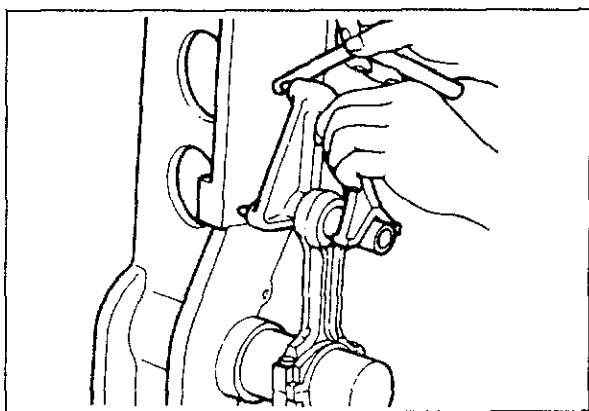

69G01B-115

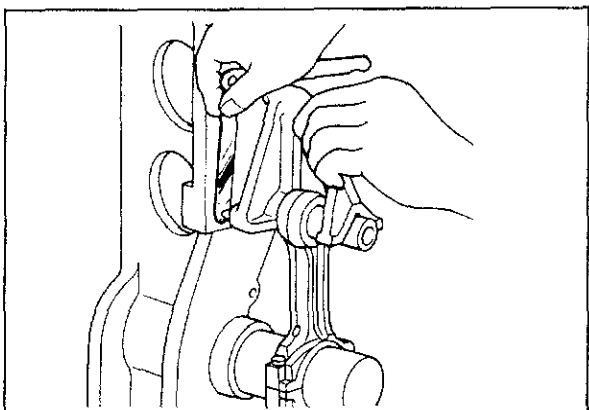

69G01B-116

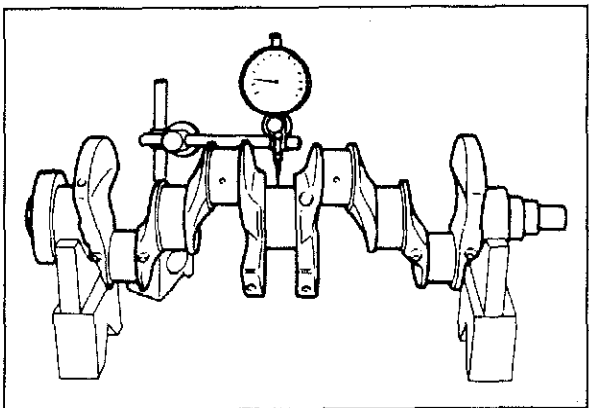

83U01A-093

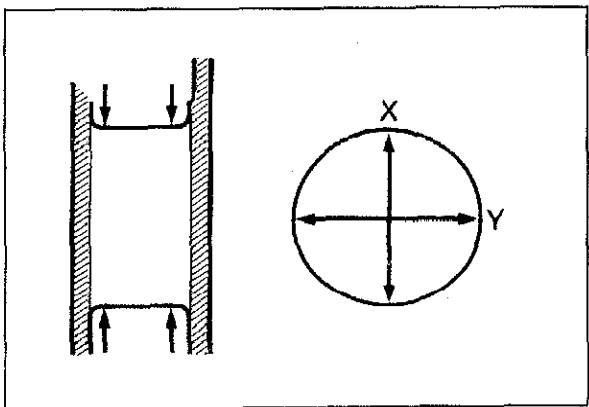

83U01A-094

3. Check each connecting rod for bending or twisting, if necessary replace or repair.

**Bend: 0.04 mm (0.0016 in) max.**

**Twist: 0.04 mm (0.0016 in) max.**

### Crankshaft

1. Check the journals and pins for damage, scoring, or oil hole clogging.
2. Set the crankshaft on V-blocks.
3. Check the crankshaft runout at the center journal, replace if necessary.

**Runout: 0.04 mm (0.0016 in) max.**

4. Measure each journal diameter in X and Y directions at two places.

### Main journal

**Diameter:**

**49.938—49.956 mm (1.9661—1.9668 in)**

**Minimum: 49.89 mm (1.964 in)**

**Out-of-round: 0.05 mm (0.0020 in) max.**

### Crankpin journal

**Diameter:**

**44.940—44.956 mm (1.7693—1.7699 in)**

**Minimum: 44.89 mm (1.7673 in)**

**Out-of-round: 0.05 mm (0.0020 in) max.**

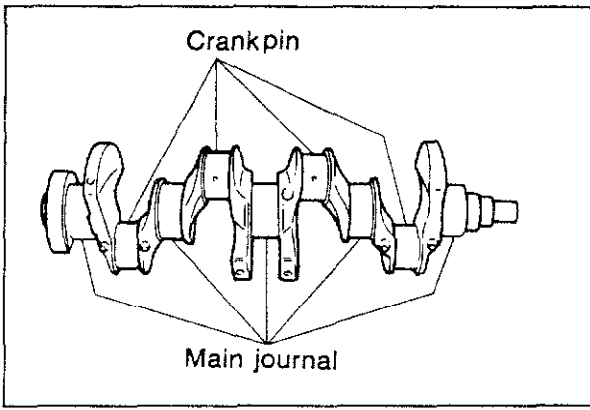

83U01A-095

5. If the diameter is below the minimum, grind the journals to match undersize bearings.

**Undersize bearing:**

**0.25 mm (0.010 in), 0.50 mm (0.020 in)**

**Main journal diameter undersize mm (in)**

Bearing size	Journal diameter
0.25 undersize	49.688—49.706 (1.9562—1.9569)
0.50 undersize	49.438—49.456 (1.9464—1.9471)

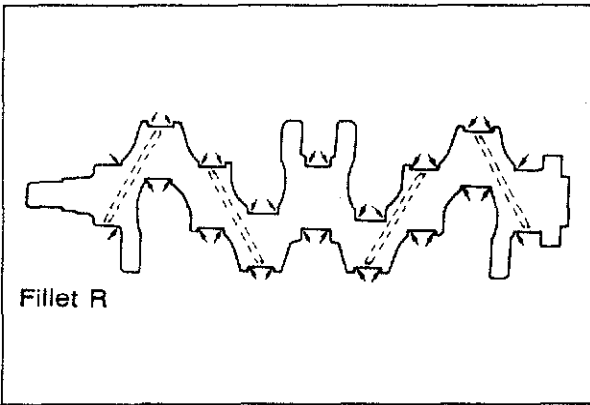

83U01A-096

**Crankpin journal diameter undersize mm (in)**

Bearing size	Journal diameter
0.25 undersize	44.690—44.706 (1.7594—1.7601)
0.50 undersize	44.440—44.456 (1.7496—1.7502)

**Caution**

**Do not grind the fillet roll.**

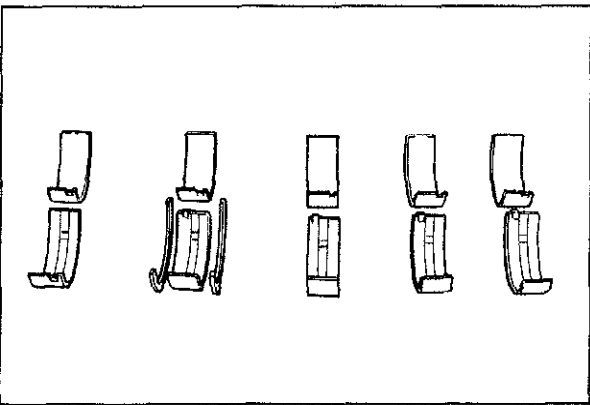

83U01A-097

**Main Bearing and Connecting Rod Bearing**

Check the main bearings and the connecting rod bearings for peeling, scoring, or other damage.

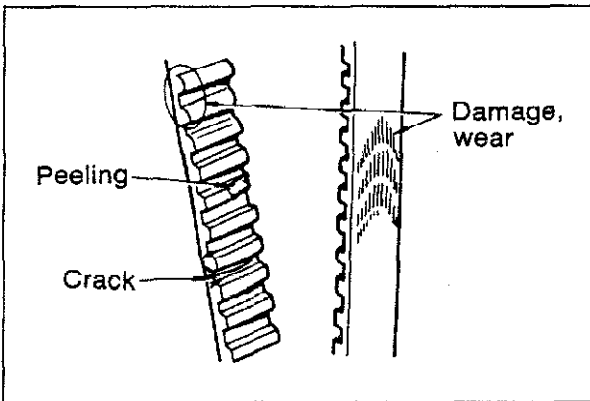

69G01B-121

**Timing Belt**

1. Replace the timing belt if there is any oil or grease on it.
2. Check the timing belt for damage, wear, peeling, cracks, or hardening, replace if necessary.

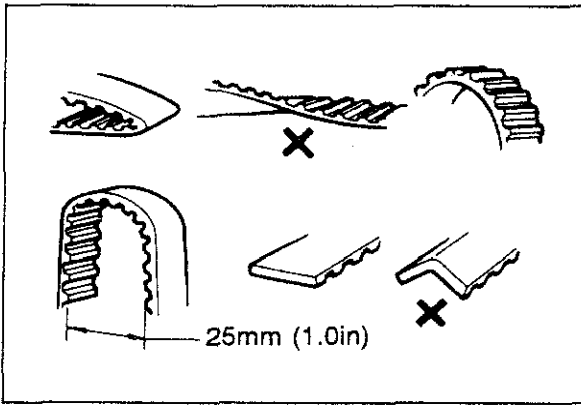

69G01B-122

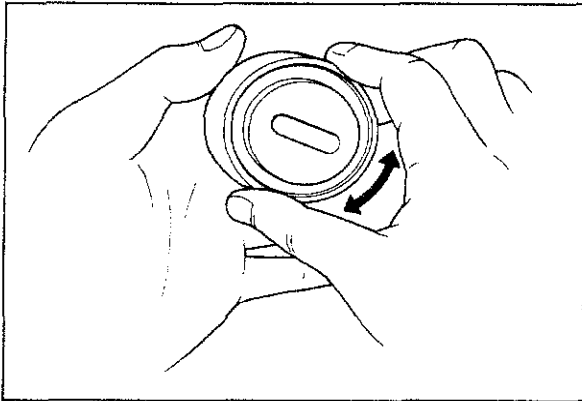

83U01A-098

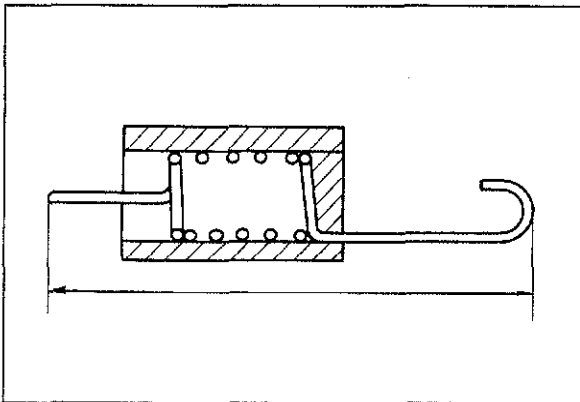

83U01A-099

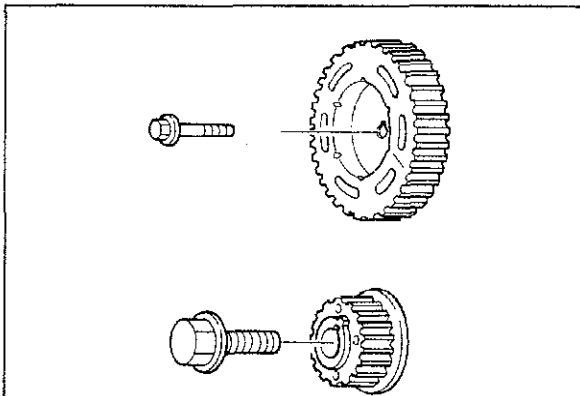

69G01B-125

### Caution

- a) Never forcefully twist the timing belt. Do not turn it inside out or bend it.
- b) Be careful not to allow oil or grease on the belt.

### Timing Belt Tensioner and Idler Pulley

Check the timing belt tensioner and idler pulley for smooth rotation or abnormal noise, replace if necessary.

### Caution

Do not clean the tensioner with cleaning fluids. If necessary, use a soft rag to wipe it clean, and avoid scratching it.

### Timing Belt Tensioner Spring

Check the free length of the tensioner spring, replace if necessary.

### Free length:

64.0 mm (2.520 in)

### Timing Belt Pulley and Camshaft Pulley

Inspect the pulley teeth for wear, deformation, or other damage, replace the pulley if necessary.

### Caution

Do not clean the pulley with cleaning fluids. If necessary, use a rag to wipe it clean.

### Timing Belt Cover (lower and upper)

Inspect the timing belt covers for deformation or cracks, replace if necessary.

## ASSEMBLY

### Assembly Note

1. Be sure all parts are clean before reinstallation.
2. Apply new engine oil to all sliding and rotating parts.
3. Do not reuse gaskets or oil seals.
4. During assembly, inspect all critical clearances, end plays and oil clearances.
5. Tighten bolts to the specified torques.
6. Replace bearings if they are peeling, burned, or otherwise damaged.

4BG01A-136

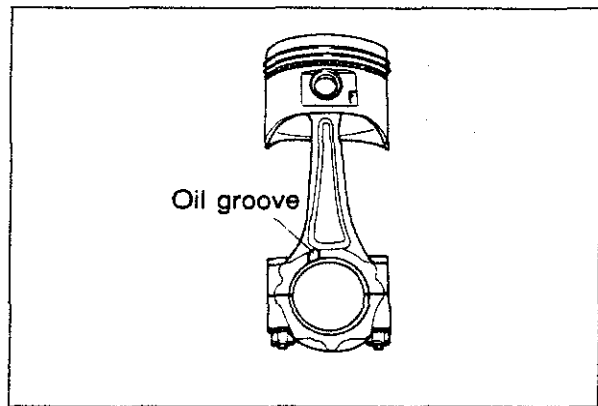

63U01X-093

### Connecting Rod

1. Align the oil groove in the large end of the connecting rod opposite the "F" mark on the piston.
2. Apply a coat of engine oil to the circumference of each piston pin and to the small end of each connecting rod.

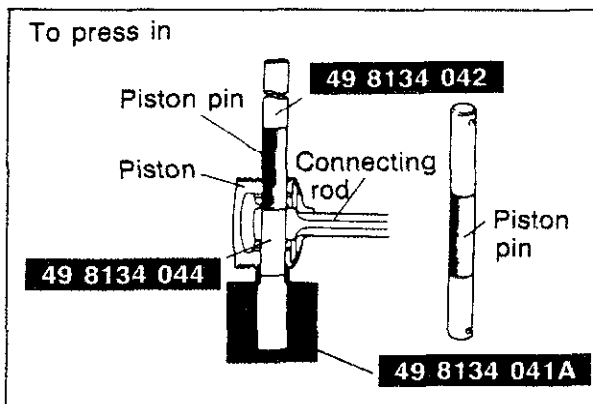

83U01A-100

3. Set the **SST** in position as shown in the figure.
4. Insert the piston pin from the direction of the "F" mark on the piston.
5. Press the upper part of the **SST** (49 8134 042) with a press to force in the piston pin.
6. The piston pin should go in until the lower end of the **SST** (49 8134 044) meets the bottom of the **SST** (49 8134 041A).

**Pressure force: 4.9—14.7 kN**  
(500—1,500 kg, 1,100—3,300 lb)

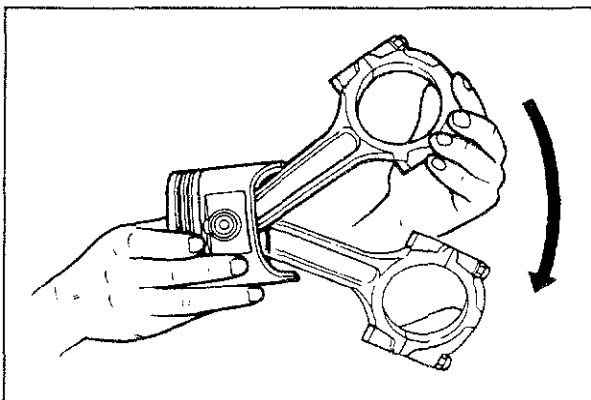

4BG01A-142

7. If the piston pin cannot be pressed in within the specified pressures, replace the piston pin or the connecting rod.
8. Check the oscillation torque of the connecting rod as shown in the figure. If the large end does not drop by its own weight, replace the piston and piston pin.

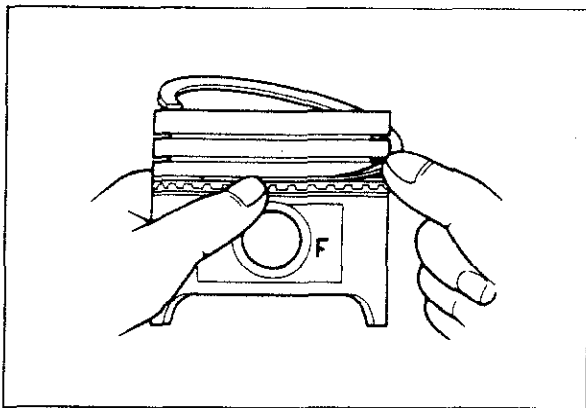

4BG01A-143

## Piston Ring

1. Install the three-piece oil rings on the pistons.
  - (1) Apply engine oil to the oil ring spacer and rails.
  - (2) Install the oil ring spacer.
  - (3) Install the upper rail and lower rail.

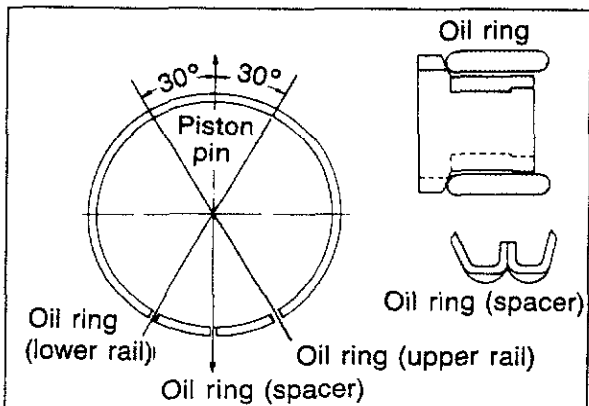

4BG01A-144

## Caution

- a) After installation of the upper and lower side rails, make certain they turn smoothly in both directions.
- b) Do not align the end gaps, stagger them.

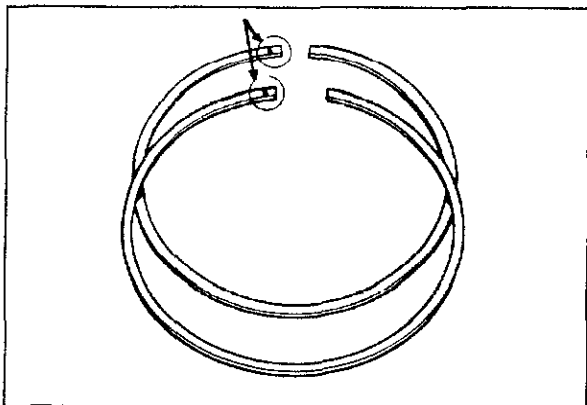

4BG01A-145

2. Install the second and top ring.
  - (1) Apply a liberal coat of engine oil to the piston rings.
  - (2) Install the second ring to the piston first, then the top one, using a piston ring insertion tool, (commercially available).

## Caution

The rings must be installed so the "R" marks face upward.

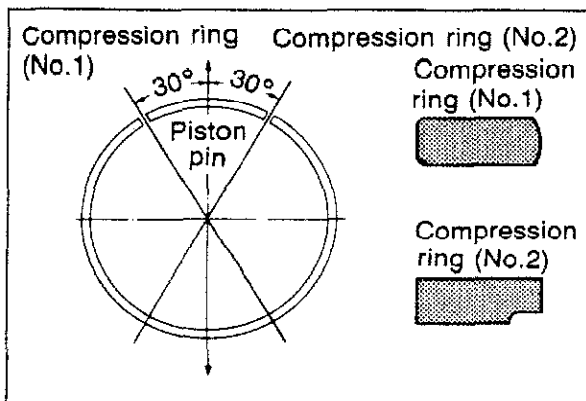

5BU01X-208

- (3) Position the opening of each ring as shown in the figure.

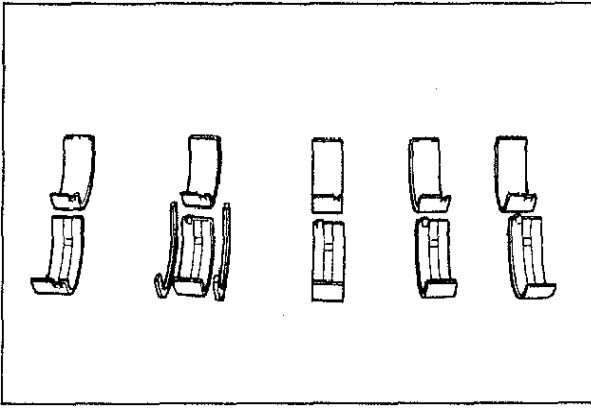

73U01X-004

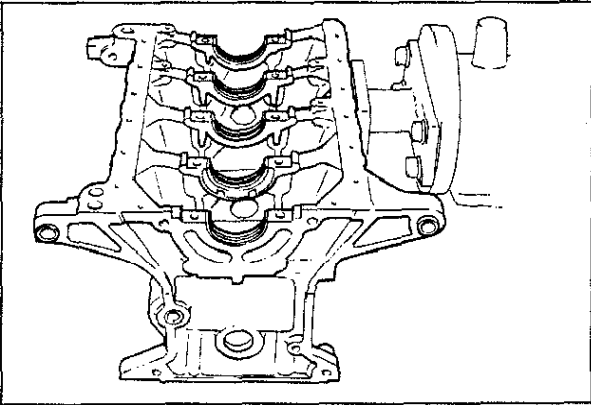

4BG01A-147

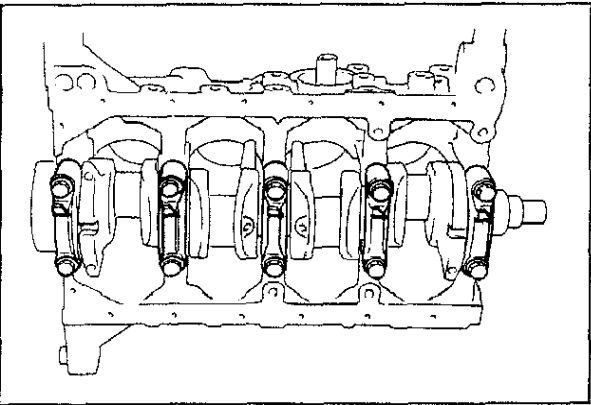

63U01X-096

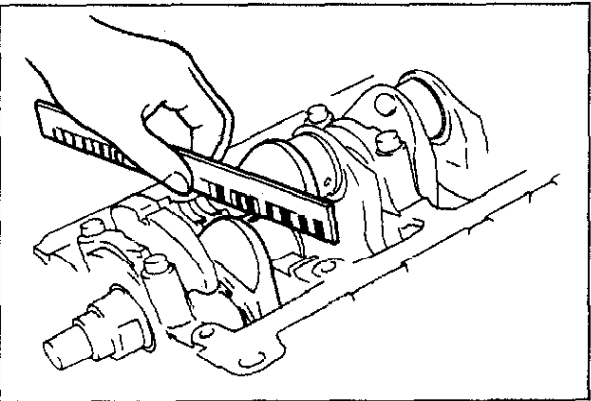

63U01A-101

## Crankshaft

1. Inspect the oil clearances of the crankshaft and main bearings.

### Caution

The main bearing with the oil grooves must be installed in the cylinder block.

- (1) Remove any foreign material and oil from the journal and bearing.
- (2) Install the main bearings and the crankshaft.
- (3) Position the plasti-gauge on top of each journal (in the journal axial direction), away from the oil hole.

- (4) Set the main bearing caps according to the cap number and  mark, and tighten it.

### Note

Do not rotate the crankshaft when measuring the oil clearances.

### Tightening torque:

54—59 N·m (5.5—6.0 m·kg, 40—43 ft·lb)

- (5) Remove the main bearing cap, and measure the plasti-gauge at each journal at the widest point for the smallest clearance, and at the narrowest point for the largest clearance.

### Oil clearance:

0.024—0.042 mm (0.0009—0.0017 in)

### Maximum:

0.10 mm (0.0039 in)

- (6) If the oil clearance exceeds the limit, grind the crankshaft and use undersize main bearings.

### Undersize main bearings:

0.25 mm (0.010 in), 0.50 mm (0.020 in)

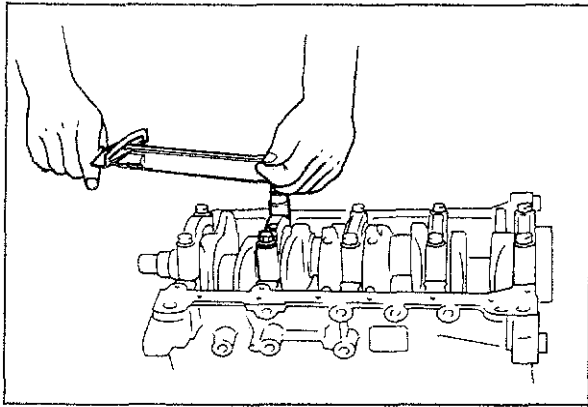

63U01X-098

2. Apply engine oil to the main bearings and main journals.
3. Install the thrust bearings to the cylinder block side.
4. Install the crankshaft, and install the main bearing caps according to the cap number and  mark.

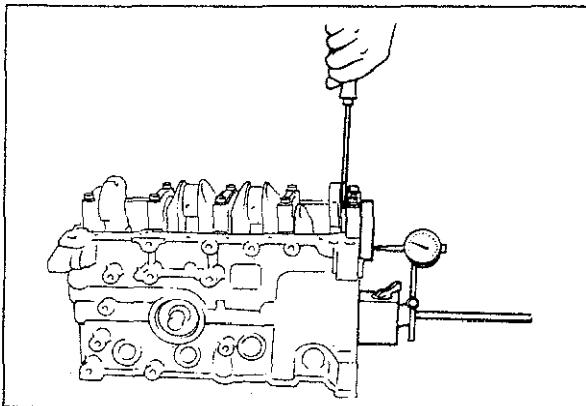

63U01X-099

5. Inspect crankshaft end play.

**End play:**  
0.08—0.282 mm (0.0031—0.0111 in)  
**Maximum:**  
0.30 mm (0.012 in)

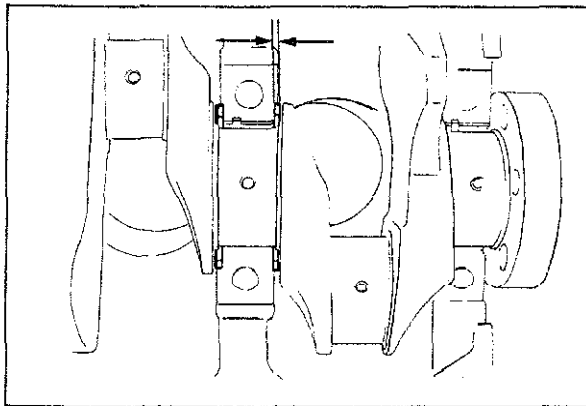

83U01A-102

If end play exceeds the limit, adjust the end play with thrust bearings.

**Standard thickness:**  
2.50—2.55 mm (0.0984—0.1004 in)  
**Undersize width:**  
0.25 mm (0.010 in):  
2.625—2.675 mm (0.1033—0.1053 in)  
0.50 mm (0.020 in):  
2.750—2.800 mm (0.1083—0.1102 in)

**Note**  
Oil groove of the thrust bearing must face the crankshaft.

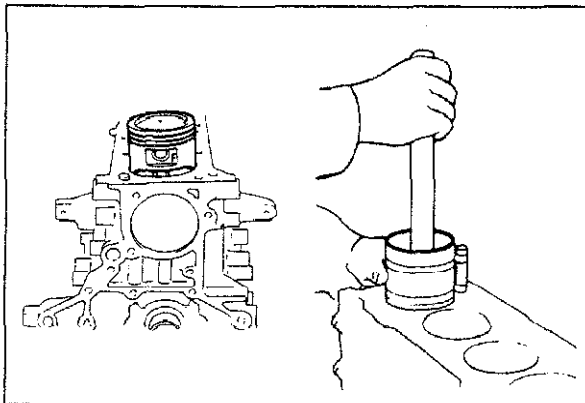

4BG01A-154

### Piston and Connecting Rod Assembly

1. Apply engine oil to the cylinder walls, piston circumference, and rings.
2. Insert each piston and connecting rod into the cylinder block by using a piston insertion tool, (commercially available).

**Caution**  
The pistons must be inserted so that the "F" marks face the front of the cylinder block.

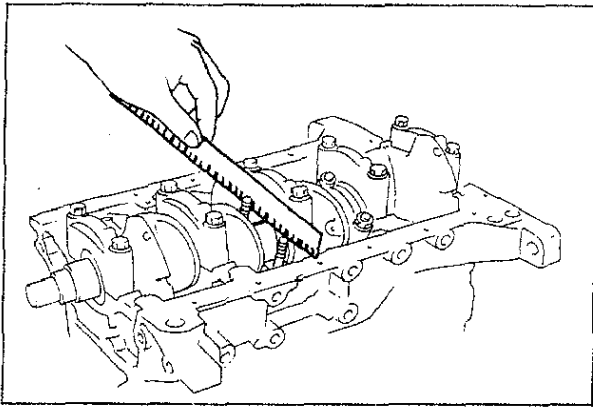

83U01A-103

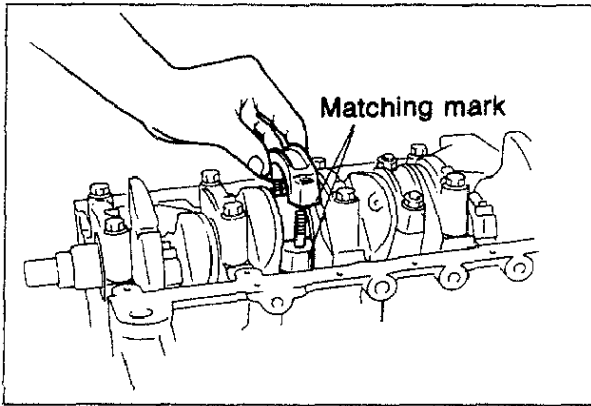

4BG01A-156

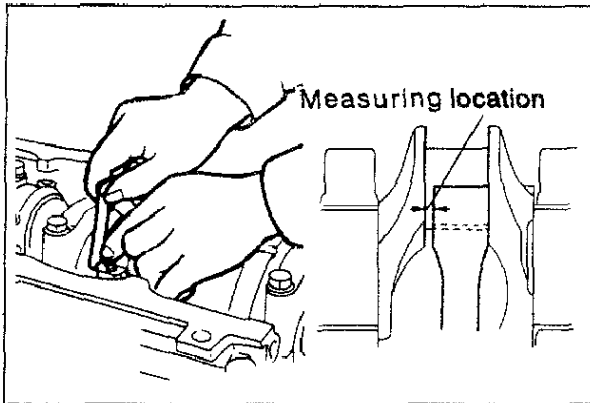

4BG01A-157

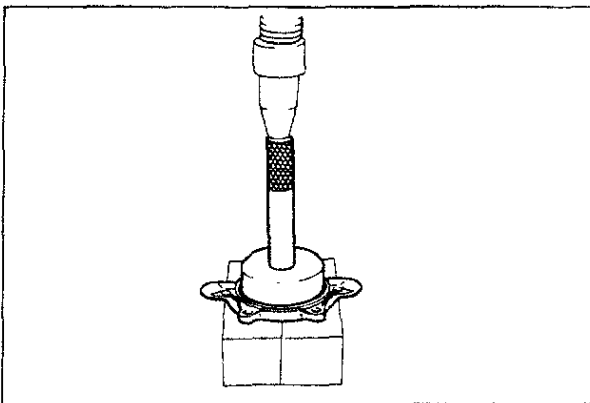

63U01X-102

## Connecting Rod Cap

1. Inspect and adjust the connecting rod bearing and crankshaft pin journal oil clearance by the same procedure used for the crankshaft and main bearing oil clearance.

### Connecting rod cap tightening torque:

47—52 N·m (4.8—5.3 m·kg, 35—38 ft·lb)

### Oil clearance:

0.028—0.068 mm (0.0011—0.0027 in)

### Maximum:

0.10 mm (0.0039 in)

### Undersize connecting rod bearing:

0.25 mm (0.010 in), 0.50 mm (0.020 in)

### Caution

Be sure to align the matching marks on the cap and on the connecting rod when installing the connecting rod cap.

2. Check the side clearance of the connecting rod.

**Clearance: 0.30 mm (0.012 in) max.**

### Caution

The connecting rod side clearance must be measured before installation.

3. Apply engine oil to the crankpin journal and connecting rod bearing.
4. Install the connecting rod cap to align the matching mark and tighten it.

### Tightening torque:

47—52 N·m (4.8—5.3 m·kg, 35—38 ft·lb)

## Rear Cover

1. Apply engine oil to the rear cover, oil seal and oil seal lip.
2. Press the oil seal into the rear cover.



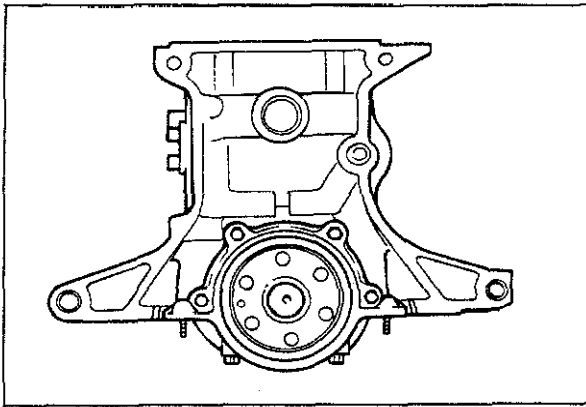

63U01X-103

3. Install the rear cover along with a new gasket.

**Tightening torque:**

**8—11 N·m (0.8—1.1 m·kg, 69—95 in·lb)**

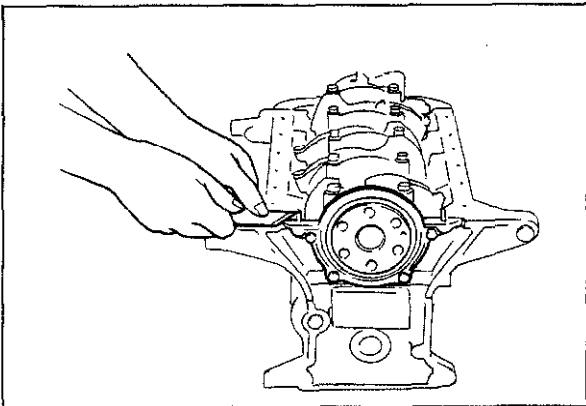

4EG01A-166

4. Cut away the part of the gasket that projects out from the rear cover assembly.

**Caution**

**Do not scratch the rear cover assembly.**

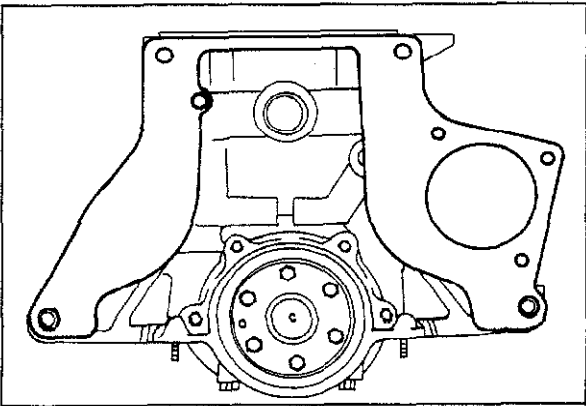

63U01X-104

**End Plate**

Install the end plate.

**Tightening torque:**

**8—11 N·m (0.8—1.1 m·kg, 69—95 in·lb)**

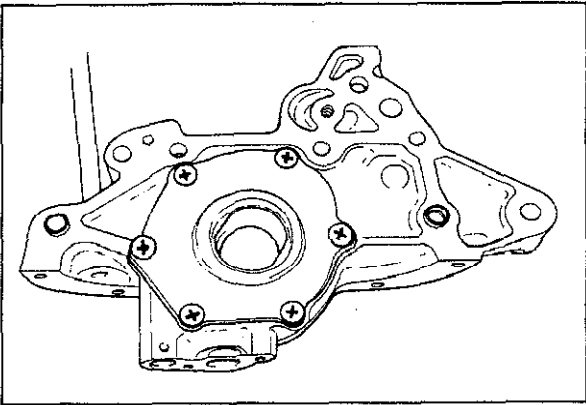

63U01X-105

**Oil Pump**

1. Remove any dirt or grease from the contact surfaces of the cylinder block and oil pump with a rag.
2. Apply engine oil to the oil seal lip.
3. Install new gasket.

**Caution**

**Do not allow any sealant in the oil hole.**

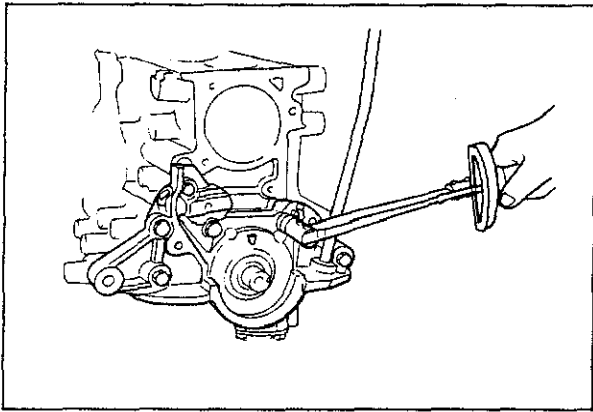

83U01A-104

4. Install the oil pump.

**Tightening torque:**

**19—26 N·m (1.9—2.6 m·kg, 14—19 ft·lb)**

5. Remove any sealant which is squeezed out.

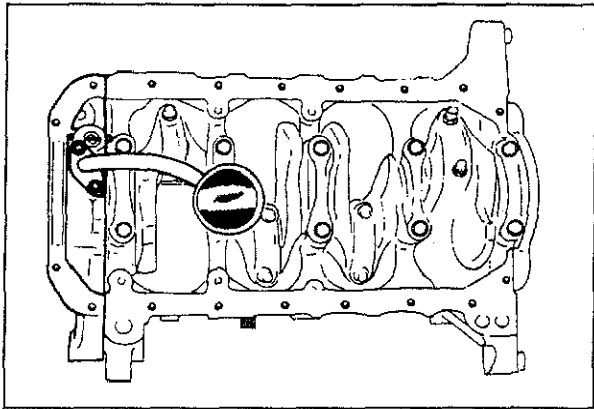

63U01X-107

**Oil Strainer**

Install the oil strainer along with a new gasket.

**Tightening torque:**

**8—11 N·m (0.8—1.1 m·kg, 69—95 in·lb)**

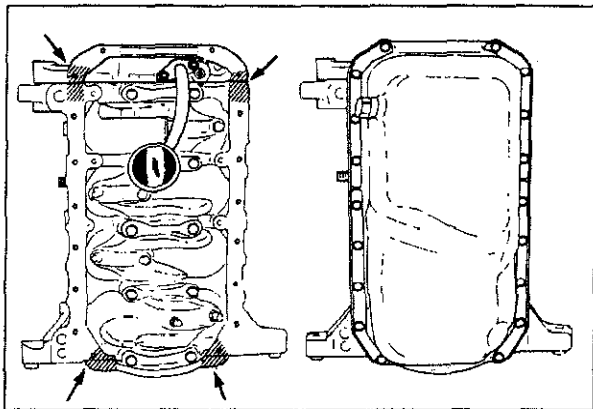

83U01A-105

**Oil Pan**

1. Apply sealant to the shaded areas as in the figure.
2. Install the oil pan along with the gasket and stiffener.

**Tightening torque:**

**6—9 N·m (0.6—0.9 m·kg, 52—78 in·lb)**

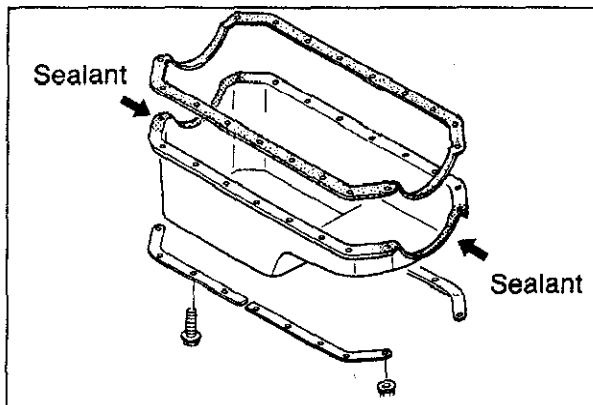

83U01A-106

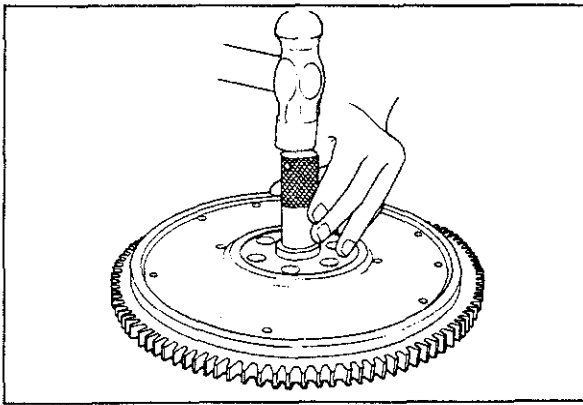

83U01A-107

## Flywheel (MTX)

1. Tap the pilot bearing in with a suitable pipe and hammer.
2. Apply sealant to the flywheel bolts.

### Caution

If reinstalling flywheel bolts, clean threads to remove old sealant, apply new sealant and tighten to specification.

If old sealant can not be removed, replace bolts.

3. Install the flywheel, with the **SST** while tightening.

### Tightening torque:

96—103 N·m (9.8—10.5 m·kg, 71—76 ft·lb)

## Drive Plate (ATX)

Install the drive plate along with the adapter and backing plate with the **SST**.

### Tightening torque:

96—103 N·m (9.8—10.5 m·kg, 71—76 ft·lb)

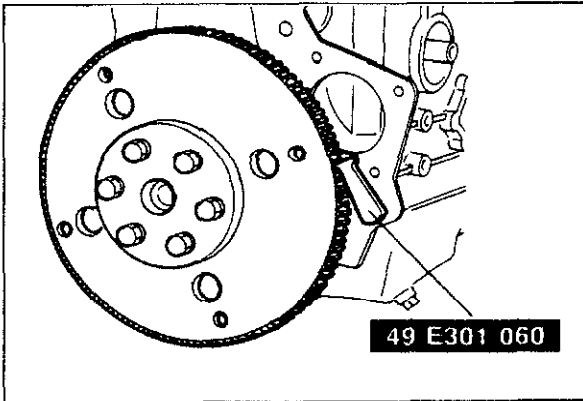

83U01A-108

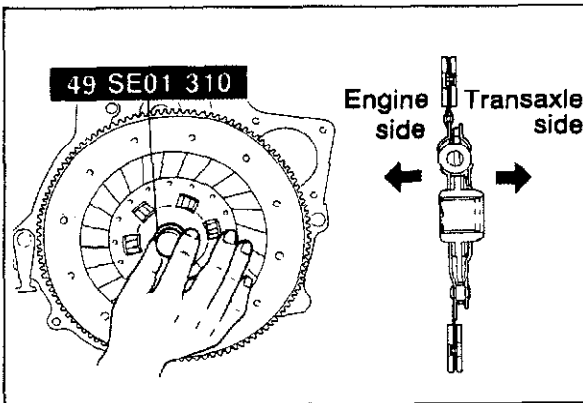

83U01A-109

## Clutch Disc and Clutch Cover

Install the clutch disc and clutch cover with the **SST**, and tighten the clutch cover.

### Tightening torque:

18—26 N·m (1.8—2.7 m·kg, 13—20 ft·lb)

### Note

Follow the clutch disc installation directions exactly (See Section 6).

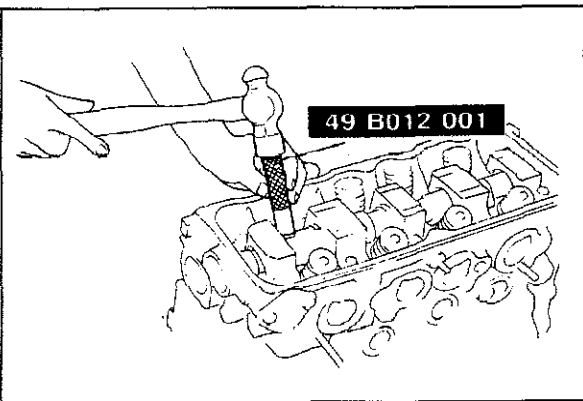

83U01X-145

## Valve Seal

1. Apply engine oil to the inner surface of the new valve seal.
2. Install the valve seal onto the valve guide with the **SST**.

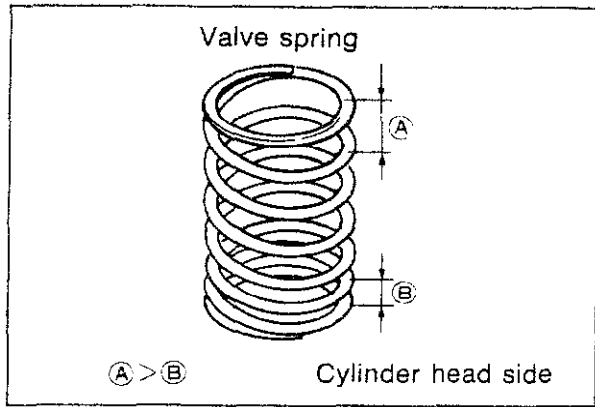

63U01X-091

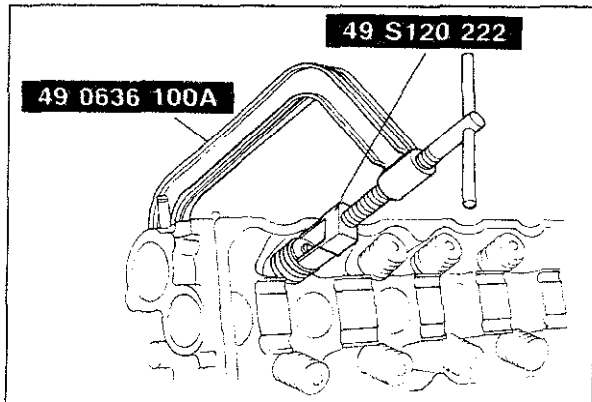

63U01X-092

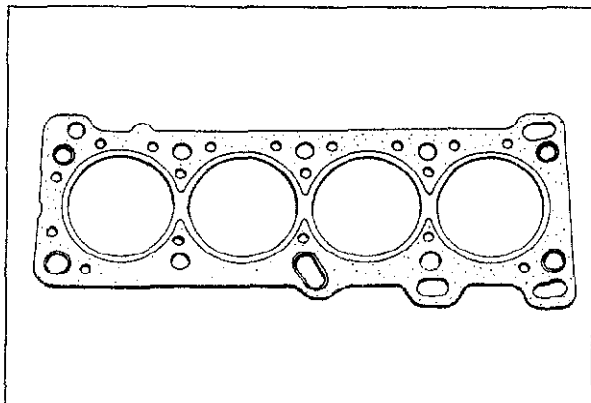

4BG01A-170

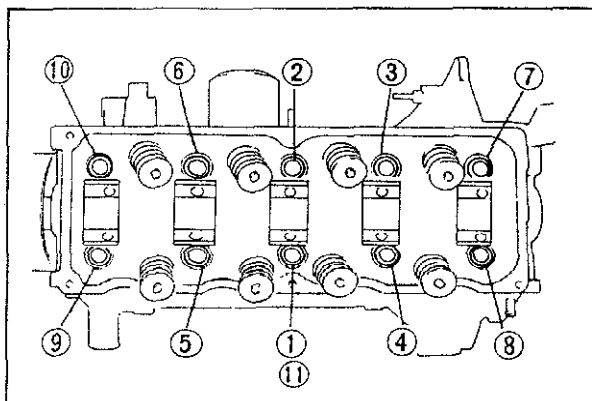

83U01A-110

## Valve and Valve Spring

1. Install the lower spring seat.
2. Install the valve.
3. Install the valve spring and the upper spring seat.

### Note

Install the spring with its narrow pitch end toward the cylinder head.

4. Install the spring retainer after compressing the valve spring with the **SST**.

## Cylinder Head

1. Thoroughly remove all dirt and grease from the top of the cylinder block with a rag.
2. Place the new cylinder head gasket in position.

3. Install the cylinder head.

### Tightening torque:

76—81 N·m (7.7—8.3 m·kg, 56—60 ft·lb)

### Caution

Tightening the bolts must be done gradually and in the order shown in the figure.

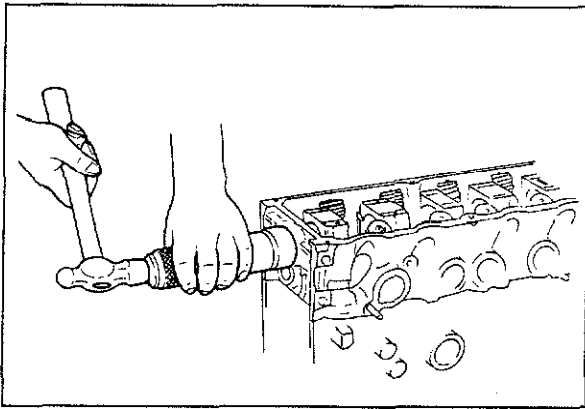

63U01X-118

## Camshaft Oil Seal

1. Apply a thin coat of engine oil to the camshaft oil seal and cylinder head.
2. Tap the camshaft oil seal into the cylinder head.

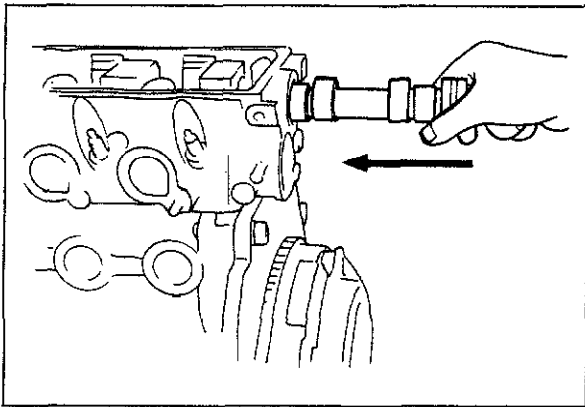

83U01A-111

## Camshaft

Apply engine oil to the journals and bearings, then insert the camshaft in position with the thrust plate.

### Tightening torque:

**8—11 N·m (0.8—1.1 m·kg, 69—95 in·lb)**

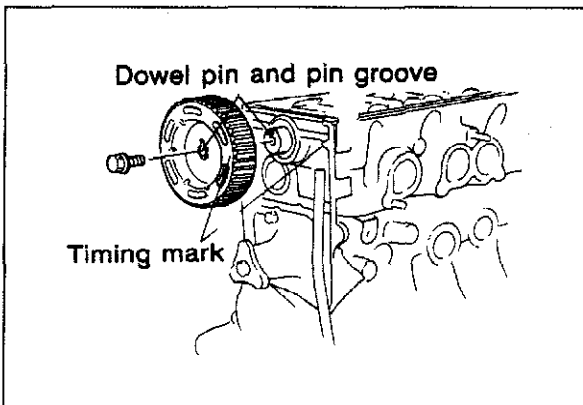

63U01X-121

## Camshaft Pulley

1. Install the camshaft pulley onto the dowel pin with the pin groove facing straight upward.

### Note

**Be certain that the dowel pin of the camshaft also faces straight upward.**

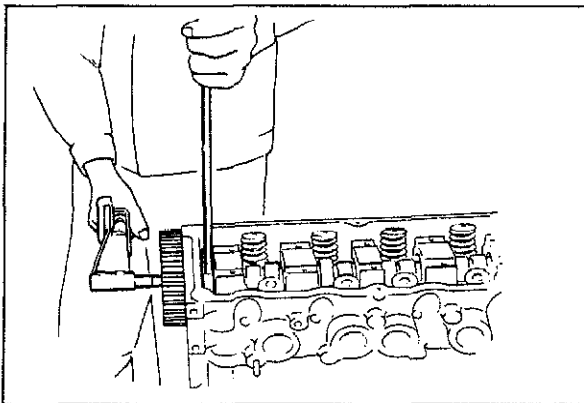

63U01X-122

2. Tighten the camshaft pulley bolt. Hold the camshaft using a suitable wrench on the cast hexagon, as shown.

### Tightening torque:

**49—61 N·m (5.0—6.2 m·kg, 36—45 ft·lb)**

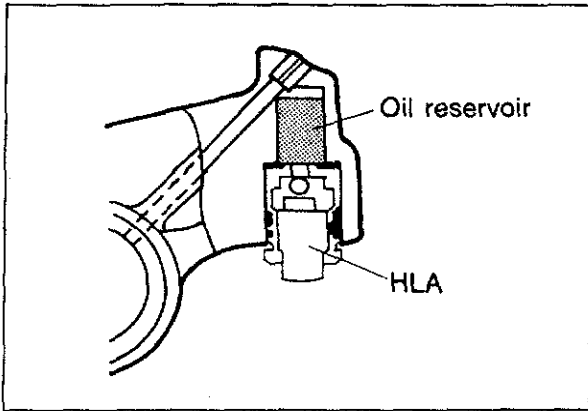

73G01A-076

### Hydraulic Lash Adjuster (HLA)

1. Pour engine oil into the oil reservoir in the rocker arm.
2. Apply engine oil to the new HLA.
3. Install the HLA in the rocker arm.

### Caution

- a) Do not remove the HLA from the rocker arm unless necessary.
- b) Be careful not to damage the O-ring when installing.

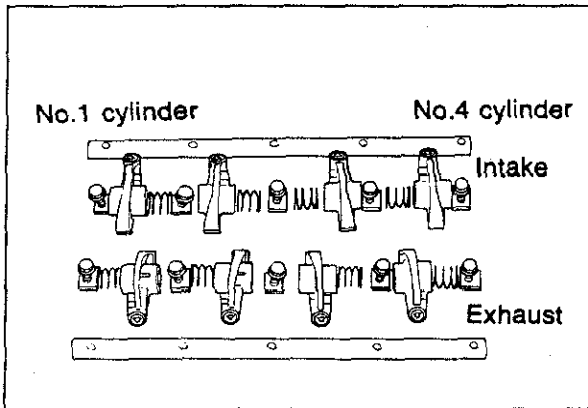

63U01X-114

### Rocker Arm and Rocker Shaft Assembly

1. Assemble the rocker arm and rocker shaft assembly as shown in the figure.

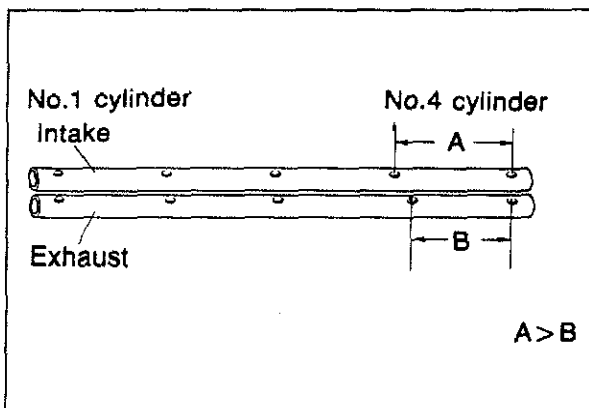

63U01X-115

### Caution

- a) Be sure both rocker arm shaft oil holes face downward.
- b) The installation bolt holes are different for the exhaust and intake sides as shown in the figure.

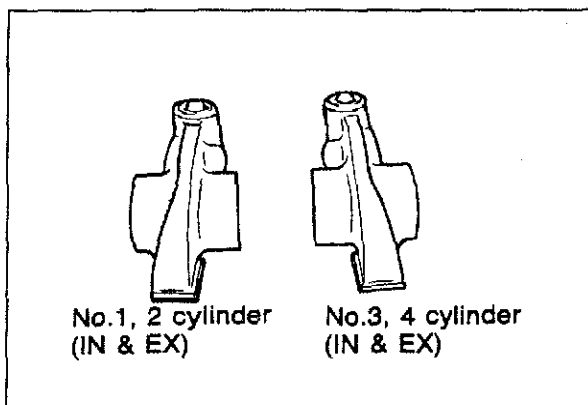

63U01X-116

### Note

There are two types of rocker arms with different offsets. The rocker arms used for No. 1 and No. 2 cylinder are the same for exhaust and intake. No. 3 and No. 4 also use the same rockers.

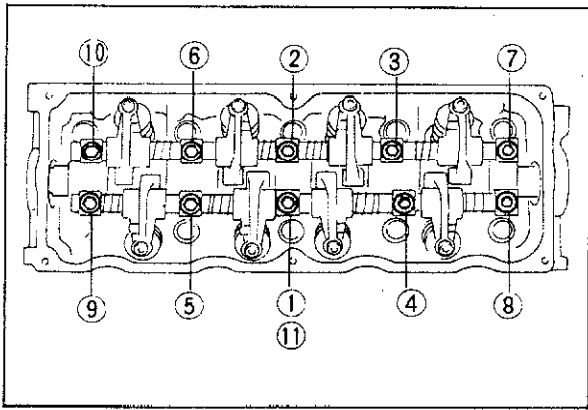

63U01X-117P

2. Install the rocker arm and rocker shaft assembly.

**Caution**

The bolts must be tightened evenly and in the order shown in the figure.

**Tightening torque:**

22—28 N·m (2.2—2.9 m·kg, 16—21 ft·lb)

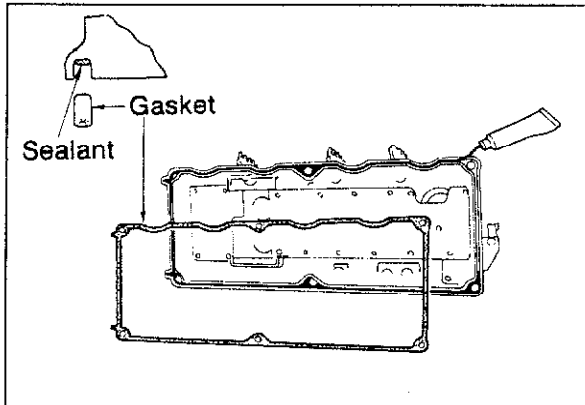

63U01X-131

**Cylinder Head Cover**

1. Apply a coat of sealant in the groove as shown.
2. Place the gasket in position.

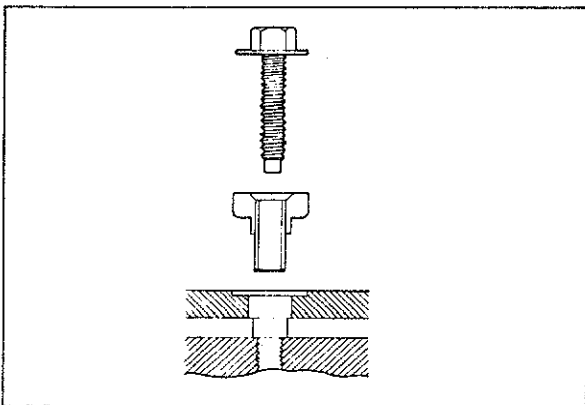

83U01A-112

3. Install the cylinder head cover with new seal washers.

**Tightening torque:**

5—9 N·m (0.5—0.9 m·kg, 43—78 in·lb)

4. Install the filler cap and the ventilation hose.

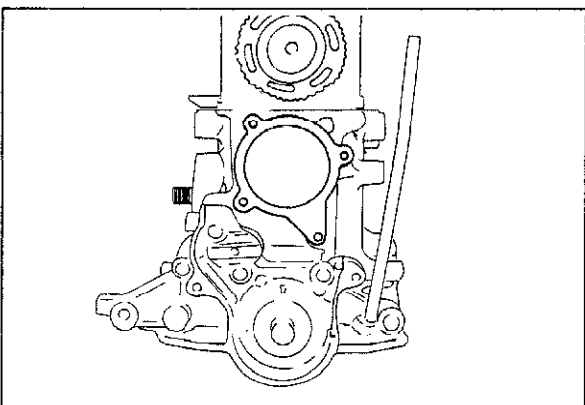

4BG01A-168

**Water Pump**

1. Remove any dirt or old gasket from the water pump mounting surface.
2. Place a new water pump gasket in position.

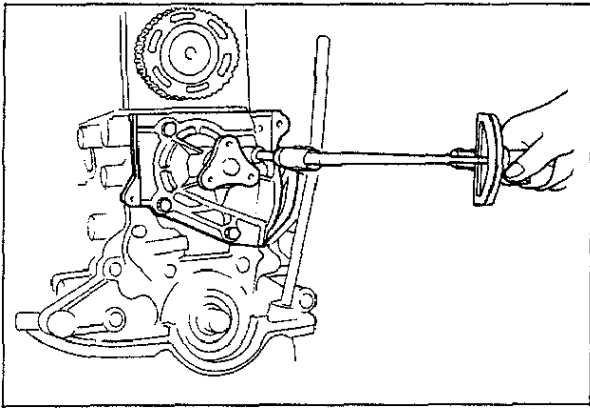

4BG01A-169P

3. Install the water pump.

**Tightening torque:**

**19—26 N·m (1.9—2.6 m·kg, 14—19 ft·lb)**

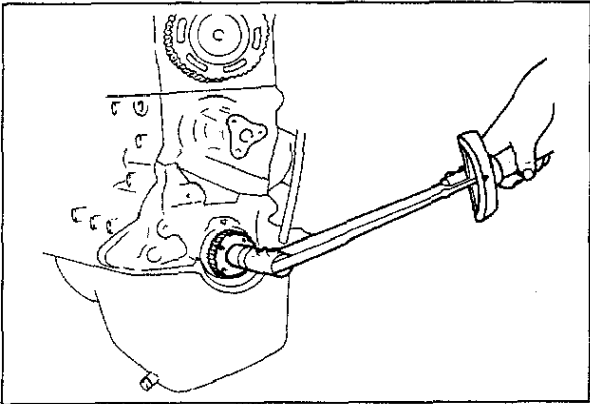

83U01A-113

**Timing Belt Pulley**

1. Reverse the direction of the (49 E301 060).
2. Install the timing belt pulley and key.
3. Apply sealant to the timing belt pulley bolt then tighten it.

**Tightening torque:**

**108—128 N·m (11.0—13.0 m·kg, 80—94 ft·lb)**

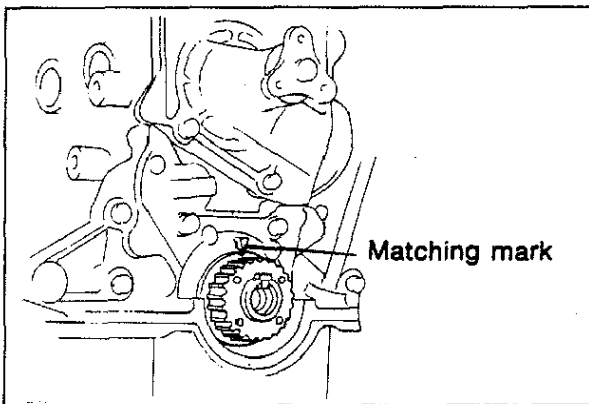

83U01X-147

4. Release the **SST** (49 E301 060).
5. Turn the crankshaft so that the timing mark on the oil pump body is aligned with the groove.

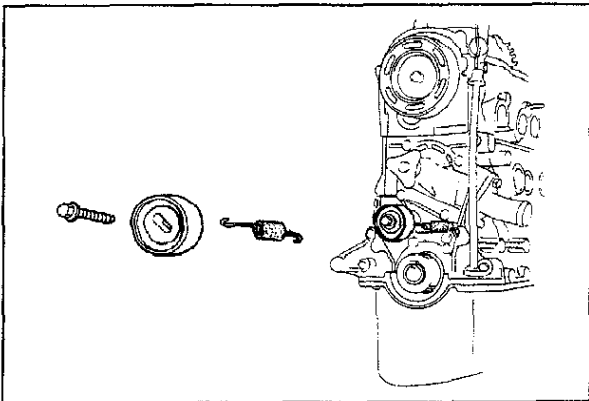

4BG01A-183

**Timing Belt Tensioner**

1. Install the timing belt tensioner.
2. Install the tensioner spring.
3. Temporarily secure the tensioner so the spring is fully extended.



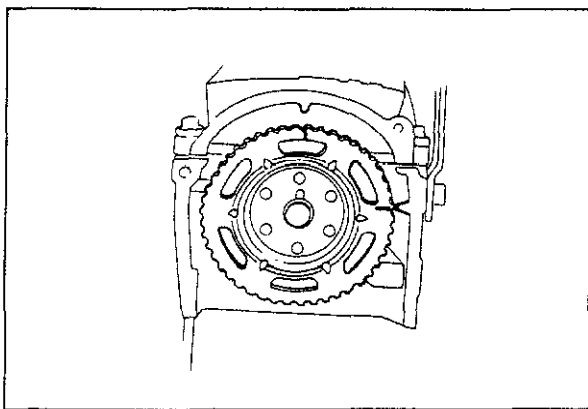

83U01A-114

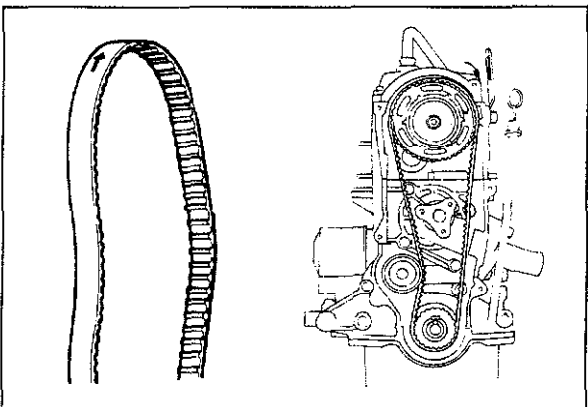

83U01A-115

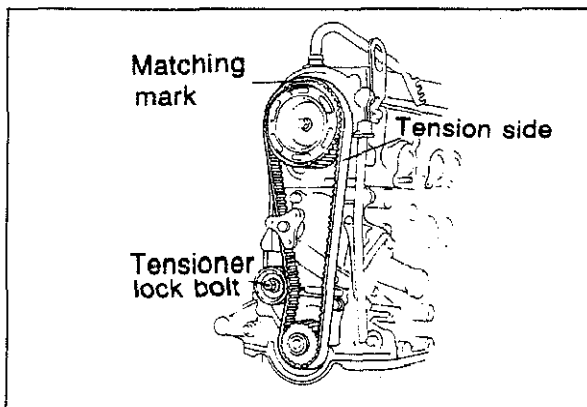

83U01A-116

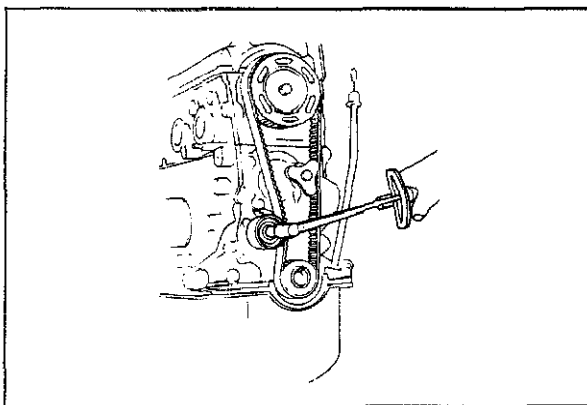

83U01A-117

## Timing Belt

1. Be sure that the timing mark on the cylinder head and the timing mark on the camshaft pulley are aligned.

2. Install the timing belt.

### Caution

- a) The timing belt must be reinstalled in the direction of previous rotation if it is reused.
- b) Be sure that there is no oil, grease, or dirt on the timing belt.

3. Turn the crankshaft twice in the direction of rotation. (Clockwise)
4. Check that the timing marks are correctly aligned. If not repeat the above-mentioned procedure.
5. Loosen the tensioner lock bolt and apply tension to the belt.

6. Tighten the timing belt tensioner to specification.

### Tightening torque:

19—26 N·m (1.9—2.6 m·kg, 14—19 ft·lb)

7. Turn the crankshaft twice in the direction of rotation and check the matching marks for alignment.

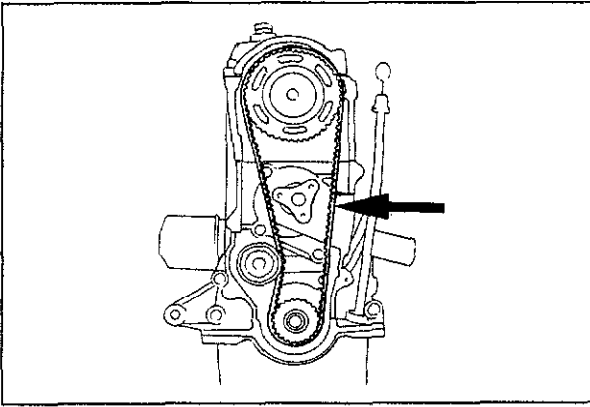

83U01A-118

8. Measure the tension between the crankshaft pulley and the camshaft pulley. If the timing belt tension is not correct, temporarily secure tensioner lock bolt so the spring is fully extended and repeat steps 3—7 above or replace the tensioner spring.

**Timing belt deflection: 12—13 mm  
(0.47—0.51 in)/98 N (10 kg, 22 lb)**

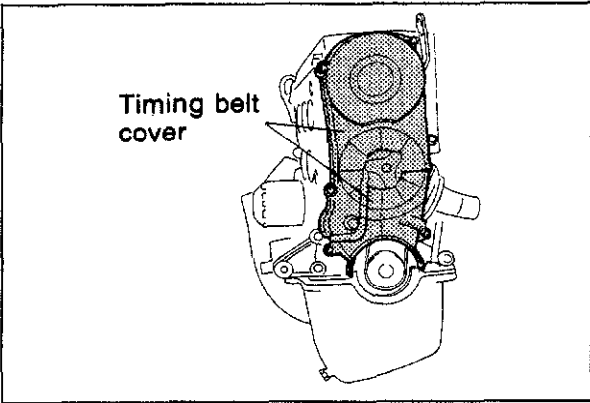

Timing belt cover

83U01A-119

### Timing Belt Cover

Install the lower and upper timing belt covers and new gaskets.

**Tightening torque:  
8—11 N·m (0.8—1.1 m·kg, 69—95 in·lb)**

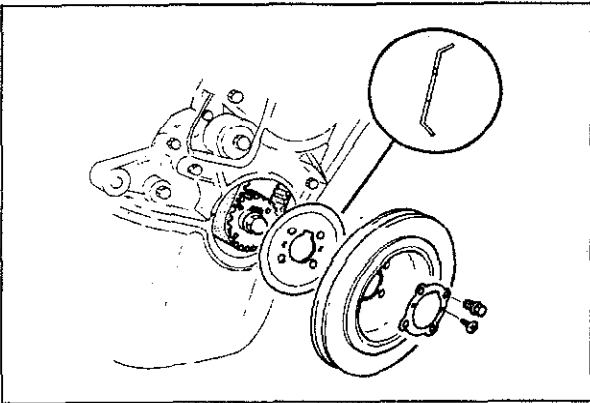

83U01A-120

### Crankshaft Pulley

Install the crankshaft pulley and baffle plate.

**Tightening torque: 12—17 N·m  
(1.25—1.75 m·kg, 109—152 in·lb)**

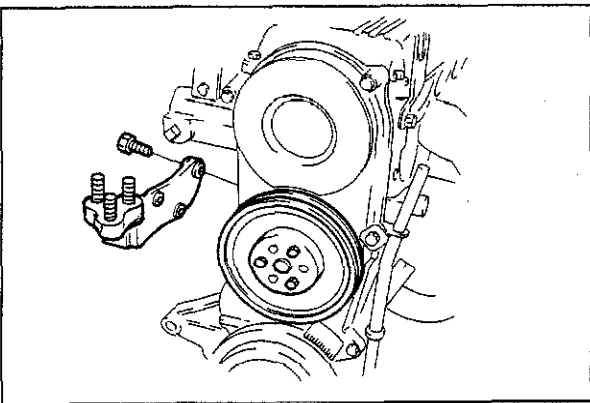

63U01X-138

### Water Pump Pulley

Install the water pump pulley.

**Tightening torque:  
8—11 N·m (0.8—1.1 m·kg, 69—95 in·lb)**

### Engine Bracket

Install the engine bracket.

**Tightening torque:  
93—113 N·m (9.5—11.5 m·kg, 69—83 ft·lb)**

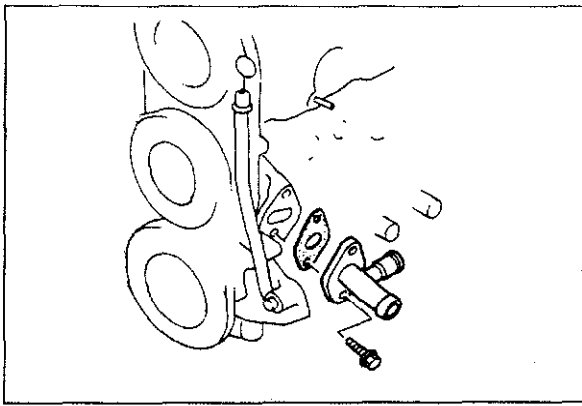

4BG01A-203

### Coolant Inlet Pipe

Install the coolant inlet pipe and a new gasket.

#### Tightening torque:

19—26 N·m (1.9—2.6 m·kg, 14—19 ft·lb)

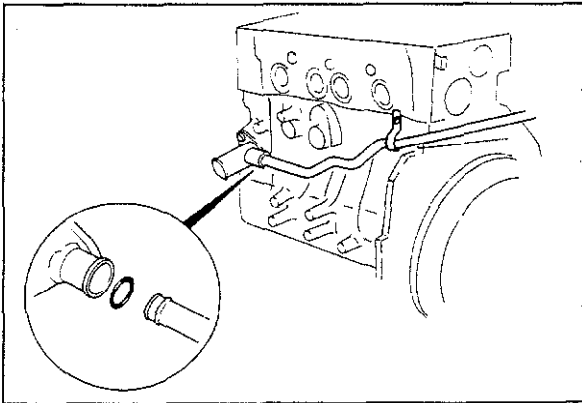

83U01A-121

### Coolant Bypass Hose

1. Apply a coat of vegetable oil to the "O" ring.
2. Install the coolant bypass hose.

#### Tightening torque:

16—23 N·m (1.6—2.3 m·kg, 12—17 ft·lb)

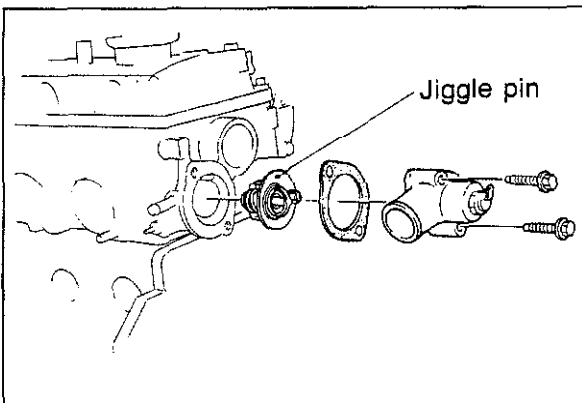

83U01A-122

### Thermostat and Thermostat Cover

1. Install the thermostat with the jiggle pin facing upward.
2. Install the thermostat cover and gasket.

#### Tightening torque:

19—26 N·m (1.9—2.6 m·kg, 14—19 ft·lb)

#### Caution

The printed side of the gasket must face the thermostat.

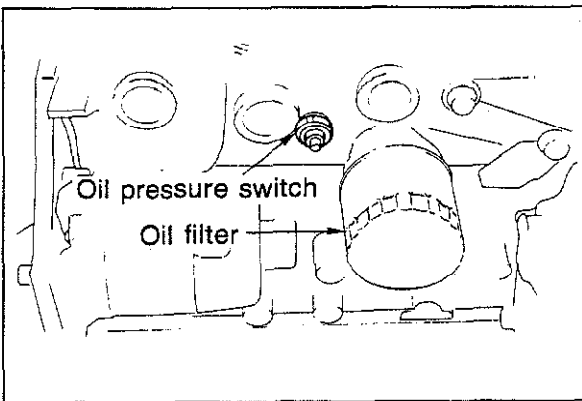

83U01A-148

### Oil Pressure Switch

Install the oil pressure switch.

#### Tightening torque:

12—18 N·m

(1.2—1.8 m·kg, 8.7—13.0 ft·lb)

### Oil Filter

Apply engine oil to the oil filter "O" ring and install the filter, tightening thoroughly by hand.

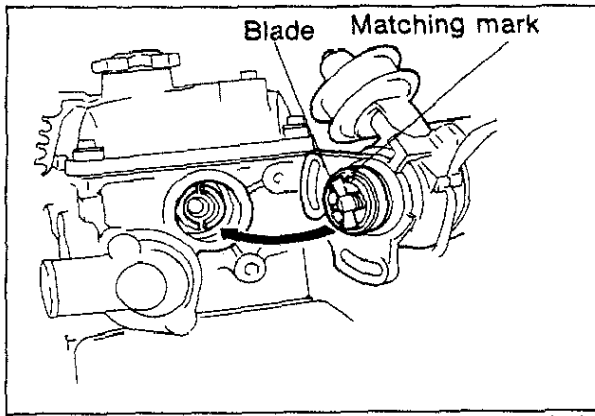

83U01A-123

### Distributor

1. Apply engine oil to the "O" ring, and position it on the distributor.
2. Apply engine oil to the drive gear.
3. Install the distributor with the blade into the camshaft groove.
4. Temporarily, loosely tighten the distributor installing bolt.

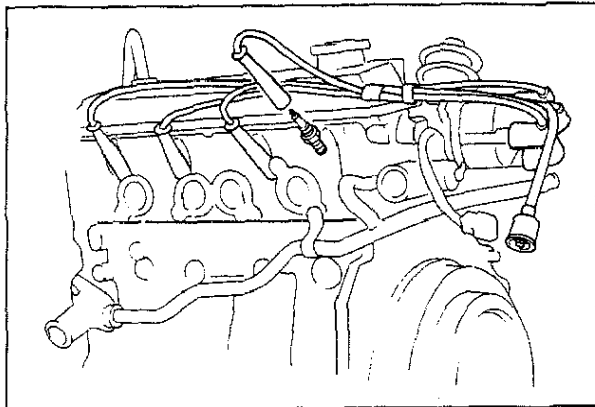

4BG01A-200

### Spark Plug and High Tension Lead

1. Install the spark plugs.

#### Tightening torque:

**15—23 N·m (1.5—2.3 m·kg, 11—17 ft·lb)**

2. Connect the high tension leads.

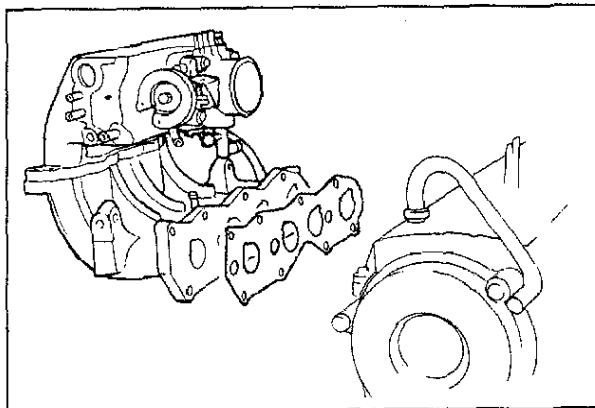

83U01X-136

### Intake Manifold Assembly

1. Install the intake manifold assembly and new gasket.

#### Tightening torque:

**19—26 N·m (1.9—2.6 m·kg, 14—19 ft·lb)**

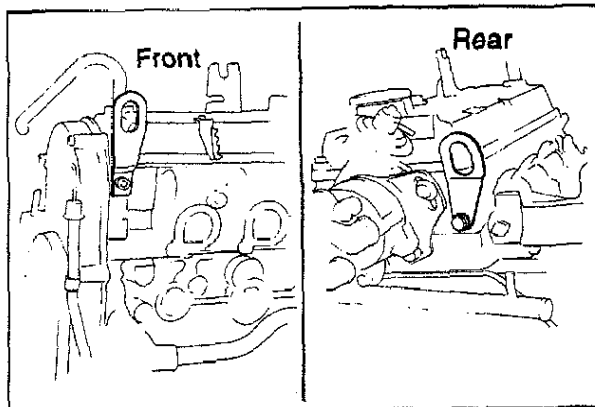

83U01A-124

### Engine Hanger

Install the front and rear engine hangers.

#### Tightening torque:

**Front: 37—63 N·m  
(3.8—6.4 m·kg, 27—46 ft·lb)**

**Rear: 19—30 N·m  
(1.9—3.1 m·kg, 14—22 ft·lb)**

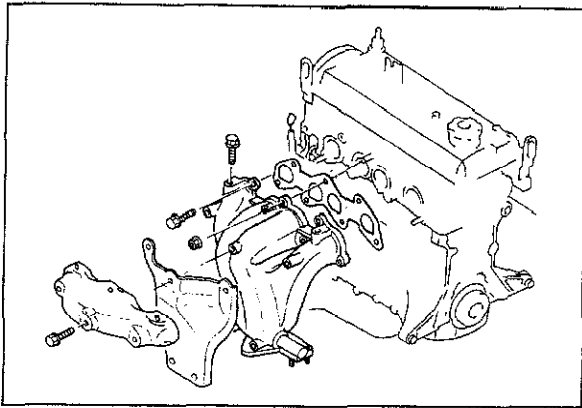

83U01A-125

## Exhaust Manifold

1. Remove the engine from the engine hanger and engine stand.
2. Install the exhaust manifold and gasket.

### Tightening torque:

**16—23 N·m (1.6—2.3 m·kg, 12—17 ft·lb)**

3. Install the exhaust manifold insulator.

### Tightening torque:

**8—11 N·m (0.8—1.1 m·kg, 69—95 in·lb)**

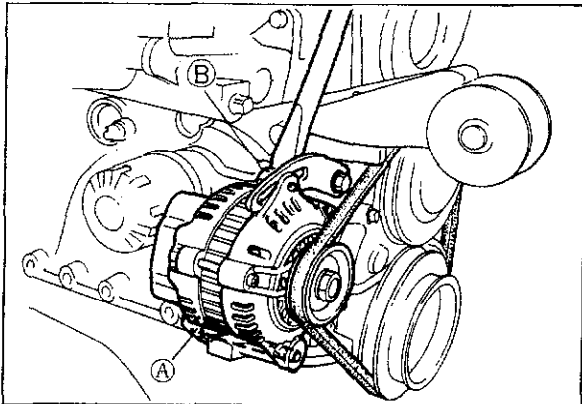

83U01A-126

## Alternator

1. Install the alternator strap.

### Tightening torque:

**37—52 N·m (3.8—5.3 m·kg, 27—38 ft·lb)**

2. Install the alternator and alternator drive belt. Loosely tighten the alternator installation bolt.
3. Adjust the drive belt deflection by referring to page 1A—6.

### Tightening torque:

**Alternator installation bolt:**

**37—52 N·m (3.8—5.3 m·kg, 27—38 ft·lb)**

**Belt adjusting bolt:**

**19—26 N·m (1.9—2.6 m·kg, 14—19 ft·lb)**

## Power Steering Pump Bracket

Install the power steering pump bracket.

### Tightening torque:

**47—66 N·m (4.8—6.7 m·kg, 35—48 ft·lb)**

## Air Conditioner Compressor Bracket

Install the air conditioner compressor bracket.

### Tightening torque:

**37—52 N·m (3.8—5.3 m·kg, 27—38 ft·lb)**

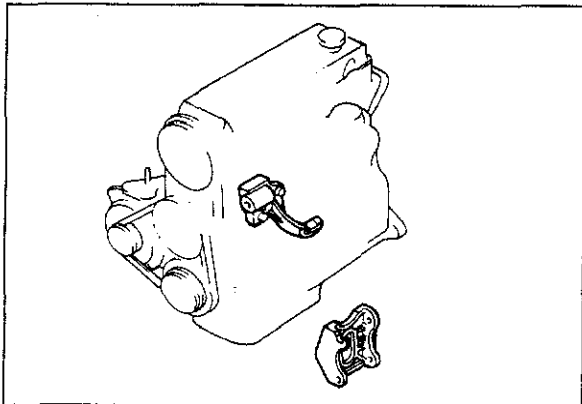

83U01A-127

# ENGINE (B6 DOHC)

<b>OUTLINE</b> .....	<b>1B— 2</b>
STRUCTURAL VIEW.....	<b>1B— 2</b>
SPECIFICATIONS.....	<b>1B— 3</b>
<b>TROUBLESHOOTING GUIDE</b> .....	<b>1B— 3</b>
<b>TUNE-UP PROCEDURE</b> .....	<b>1B— 5</b>
<b>ON-VEHICLE MAINTENANCE</b> .....	<b>1B—11</b>
TIMING BELT.....	<b>1B—11</b>
CYLINDER HEAD .....	<b>1B—15</b>
<b>REMOVAL AND INSTALLATION</b> .....	<b>1B—22</b>
<b>DISASSEMBLY</b> .....	<b>1B—26</b>
<b>INSPECTION AND REPAIR</b> .....	<b>1B—36</b>
<b>ASSEMBLY</b> .....	<b>1B—51</b>

83U01B-001

OUTLINE

STRUCTURAL VIEW

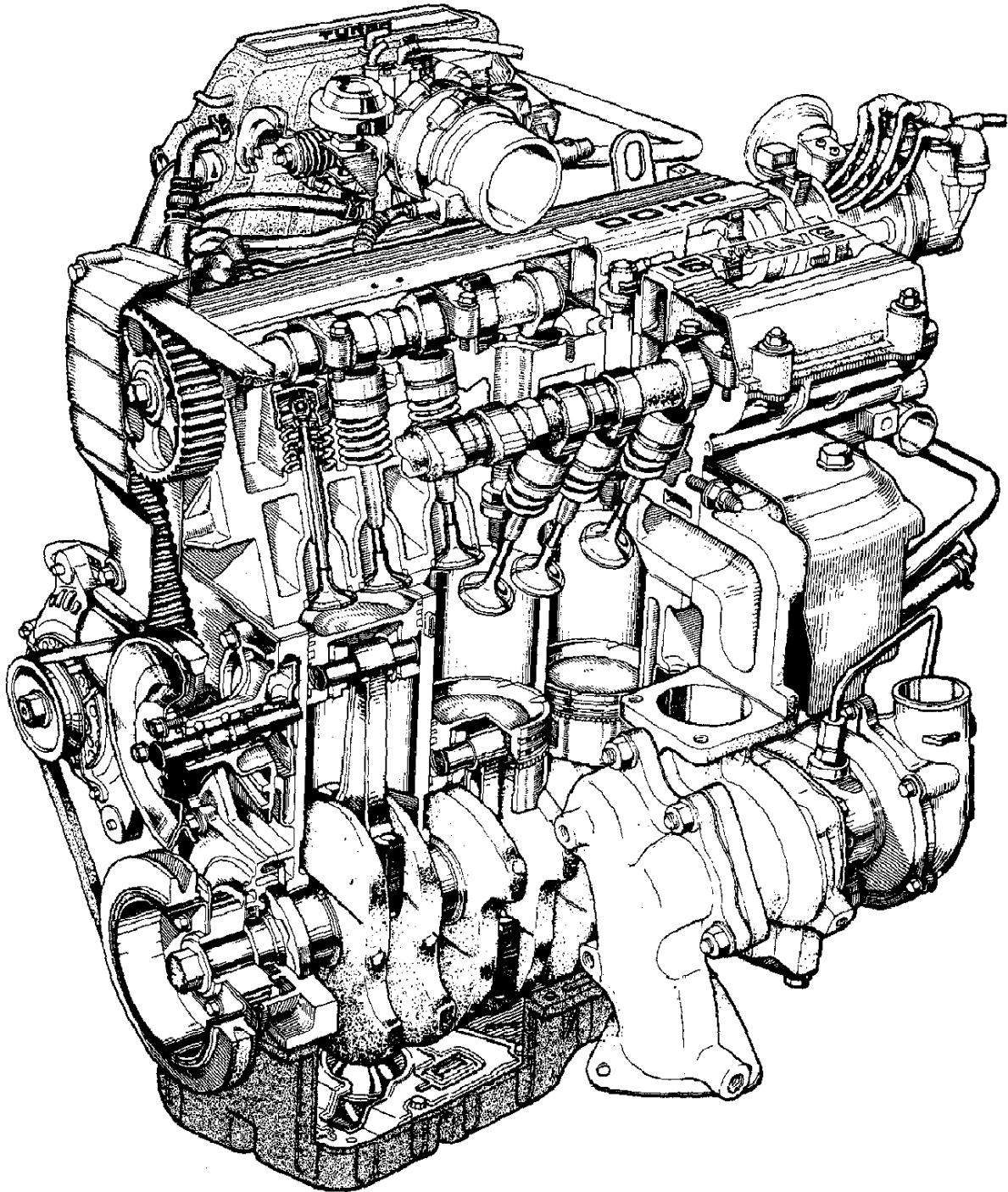

## SPECIFICATIONS

Item		Engine model	B6 DOHC
Type			Gasoline, 4-cycle
Cylinder arrangement and number			In-line 4-cylinders
Combustion chamber			Pent-roof
Valve system			OHC, belt-driven
Displacement	cc (cu in)		1,597 (97.4)
Bore and stroke	mm (in)		78 x 83.6 (3.07 x 3.29)
Compression ratio			7.9
Compression		kPa (kg/cm <sup>2</sup> , psi)—rpm	1,079 (11.0, 156) — 300
Valve timing	IN	Open BTDC	5°
		Close ABDC	51°
	EX	Open BBDC	69°
		Close BTDC	1°
Valve clearance	mm (in)	IN	0. maintenance-free
		EX	0. maintenance-free
Idle speed (MTX in neutral)	rpm		850 ± 50
Ignition timing	BTDC		12° ± 1°
Firing order			1—3—4—2

83U01B-002

## TROUBLESHOOTING GUIDE

Problem	Possible Cause	Remedy	Page
<b>Difficult starting</b>	<b>Malfunction of engine-related components</b> Burned valve Worn piston, piston ring, or cylinder Failed cylinder head gasket	Replace Replace or repair Replace	1B—37 1B—45 1B—15
	<b>Malfunction of fuel system</b>	Refer to Section 4B	
	<b>Malfunction of electrical system</b>	Refer to Section 5	
<b>Poor idling</b>	<b>Malfunction of engine-related components</b> Malfunction of HLA Poor valve to valve seat contact Failed cylinder head gasket	Replace Repair or replace Replace	1B—60 1B—39
	<b>Malfunction of fuel system</b>	Refer to Section 4B	
<b>Excessive oil consumption</b>	<b>Oil working up</b> Worn piston ring groove or sticking piston ring Worn piston or cylinder	Replace Replace or repair	1B—45 1B—45
	<b>Oil working down</b> Worn valve seal Worn valve stem or guide	Replace Replace	1B—59 1B—37
	<b>Oil leakage</b>	Refer to Section 2B	

83U01B-003



# 1B TROUBLESHOOTING GUIDE

Problem	Possible Cause	Remedy	Page
<b>Insufficient power</b>	<b>Insufficient compression</b> Malfunction of HLA Compression leakage from valve seat Seized valve stem Weak or broken valve spring Failed cylinder head gasket Cracked or distorted cylinder head Sticking, damaged, or worn piston ring Cracked or worn piston	Replace Repair Replace Replace Replace Replace Replace Replace	1B—60 1B—39 1B—37 1B—40 1B—15 1B—36 1B—46 1B—46
	<b>Malfunction of fuel system</b>	Refer to Section 4B	
	<b>Others</b> Slipping clutch Dragging brakes Wrong size tires	Refer to Section 6 Refer to Section 11 Refer to Section 12	
<b>Abnormal combustion</b>	<b>Malfunction of engine-related components</b> Malfunction of HLA Sticking or burned valve Weak or broken valve spring Carbon accumulation in combustion chamber	Replace Replace Replace Eliminate carbon	1B—60 1B—37 1B—40 —
	<b>Malfunction of fuel system</b>	Refer to Section 4B	
<b>Engine noise</b>	<b>Crankshaft or bearing related parts</b> Excessive main bearing oil clearance Main bearing seized or heat-damaged Excessive crankshaft end play Excessive connecting rod bearing oil clearance Connecting rod bearing seized or heat-damaged	Replace or repair Replace Replace or repair Replace or repair Replace	1B—54 1B—53 1B—54 1B—55 1B—55
	<b>Piston related parts</b> Worn cylinder Worn piston or piston pin Seized piston Damaged piston ring Bent connecting rod	Replace or repair Replace Replace Replace Replace	1B—44 1B—45, 46 1B—45 1B—46 1B—47
	<b>Valves or timing related parts</b> Malfunction of HLA* Broken valve spring Excessive valve guide clearance Malfunction of timing belt tensioner	Replace Replace Replace Replace	1B—60 1B—40 1B—37 1B—49
	<b>Malfunction of cooling system</b>	Refer to Section 3B	
	<b>Malfunction of fuel system</b>	Refer to Section 4B	
	<b>Others</b> Malfunction of water pump bearing Improper drive-belt tension Malfunction of alternator bearing Exhaust gas leakage	Replace Adjust Replace Repair	— 1B—6 — 1B—36

\* Tappet noise may occur if the engine is not operated for an extended period of time. The noise should disappear after the engine has reached normal operating temperature.

83U01B-004

## TUNE-UP PROCEDURE

Tune the engine according to the procedures described below.

5BU01X-006

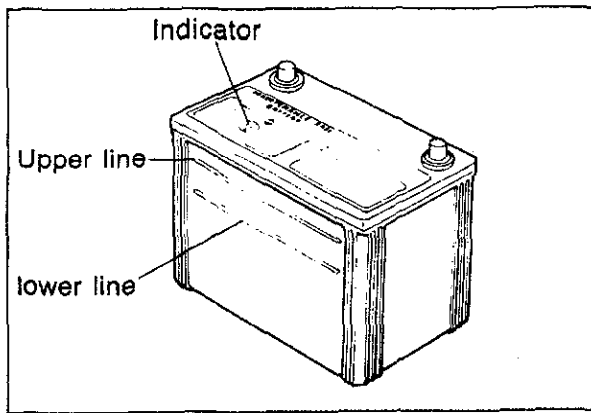

5BU01X-007

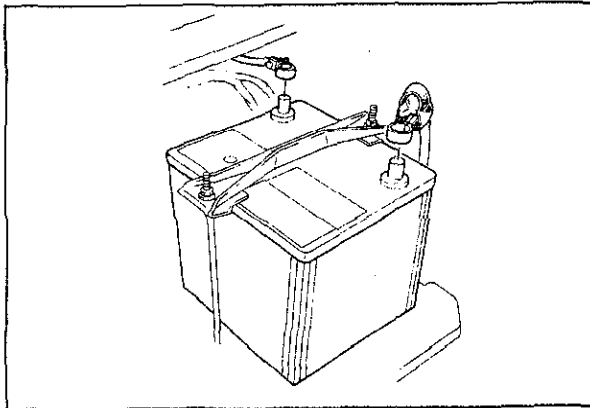

5BU01X-008

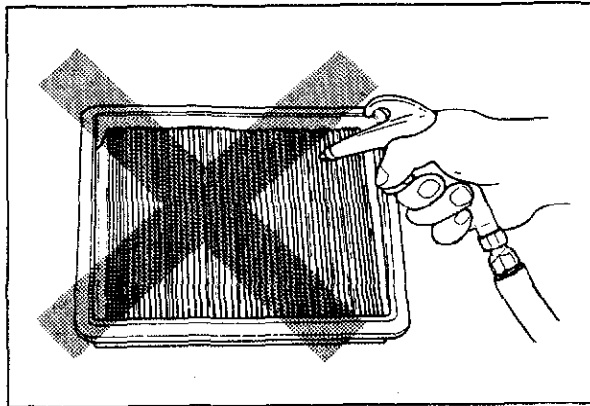

63G01D-306

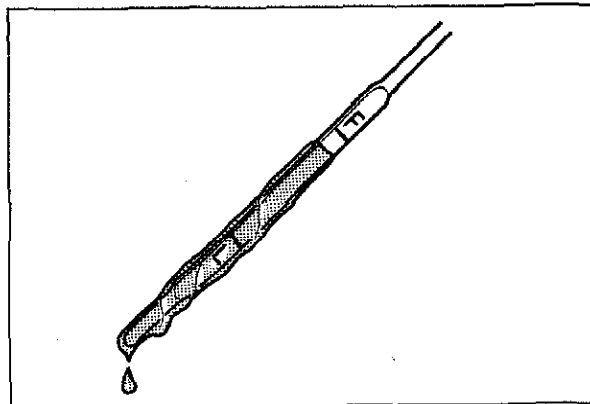

4BG01A-010

### Battery

1. Check the indicator sign on the top of the battery. If the indicator sign is blue, the battery is normal.
2. If the blue indicator sign is not visible, then the electrolyte level of the battery is low and/or the capacity is insufficient.
3. Add distilled water and/or recharge according to the procedures described in Section 5.
4. Check the tightness of the terminals to ensure good electrical connections. Clean the terminals and coat the terminals with grease.
5. Inspect for corroded or frayed battery cables.
6. Check the rubber protector on the positive terminal for proper coverage.

### Air Cleaner Element

Visually check that the air cleaner element for excessive dirt, damage or oil. Replace if necessary

### Caution

**Do not clean the air cleaner element with compressed air.**

### Engine Oil

Check the engine oil level and condition with the oil level gauge. Add oil, or change it, if necessary.

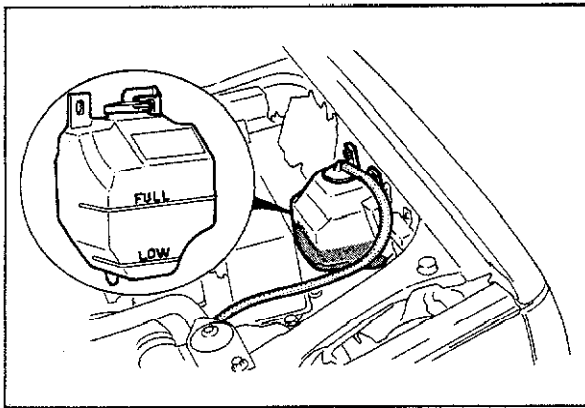

4BG01A-009

## Coolant Level

Check that the coolant level is near the radiator inlet port, and that the level in the reserve tank is between the FULL and LOW marks. Add coolant if the level is low.

### Warning

**Never remove the radiator cap while the engine is hot.**  
**Wrap a thick cloth around the cap and carefully remove the cap.**

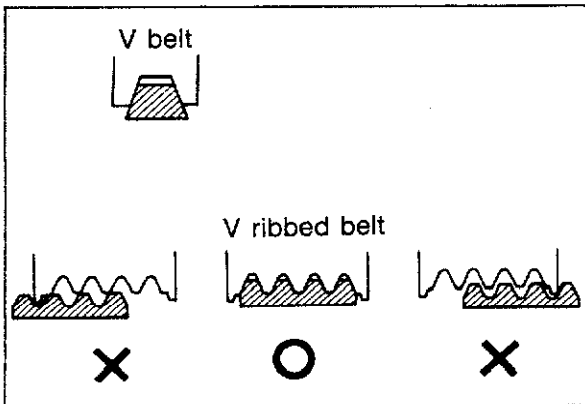

83U01A-005

## Drive Belt

1. Check that the drive belt is positioned in the pulley groove.
2. Check the drive belt for wear, cracks, or fraying.
3. Check the pulley for damage.

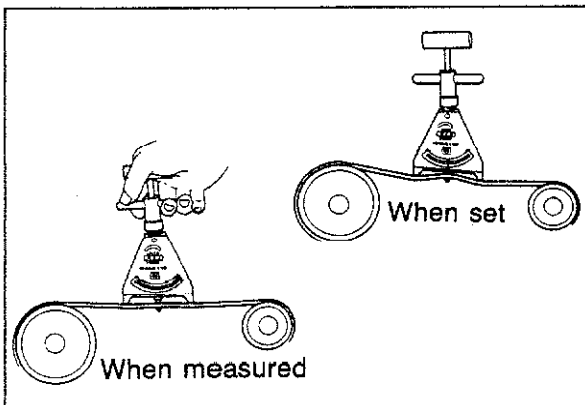

83U01A-006

## Inspection of belt tension

Check the drive belt tension by using the tension gauge.

### Standard tension

Belt	N (kg, lb)	
	New	Used
Alternator	491—589 (50—60, 110—132)	422—491 (43—50, 95—110)
A/C	491—589 (50—60, 110—132)	422—491 (43—50, 95—110)
P/S	491—589 (50—60, 110—132)	422—491 (43—50, 95—110)
A/C and P/S	491—589 (50—60, 110—132)	422—491 (43—50, 95—110)

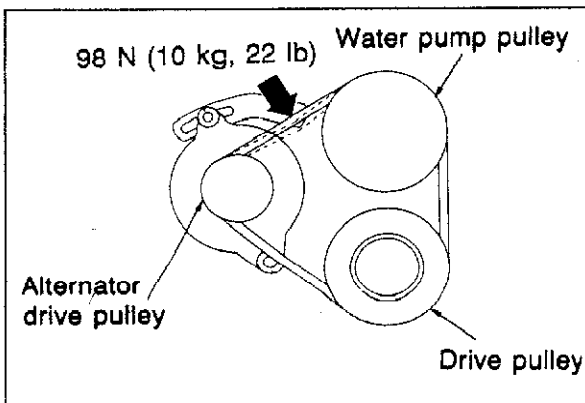

83U01A-007

## Inspection of belt deflection

Check the drive belt deflection by applying moderate pressure (98 N, 10 kg, 22 lb) midway between the pulleys.

### Alternator drive belt

**New: 8—9 mm (0.31—0.35 in)**  
**Used: 9—10 mm (0.35—0.39 in)**

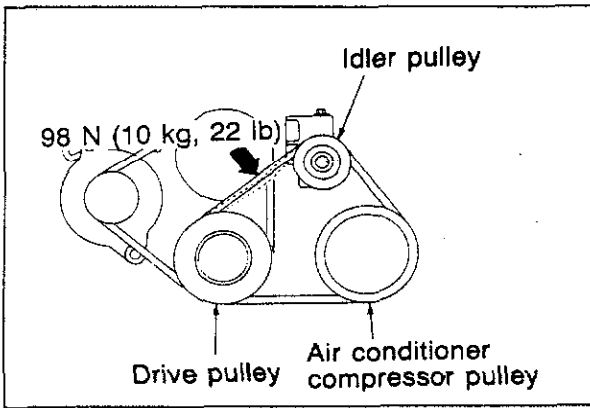

83U01A-008

A/C drive belt

**New: 8—9 mm (0.31—0.35 in)**  
**Used: 9—10 mm (0.35—0.39 in)**

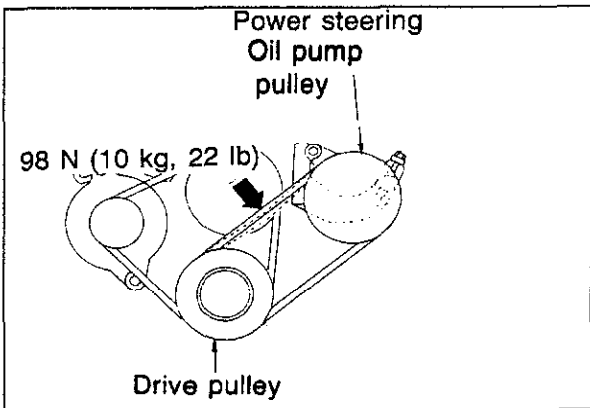

83U01A-009

P/S oil pump drive belt

**New: 8—9 mm (0.31—0.35 in)**  
**Used: 9—10 mm (0.35—0.39 in)**

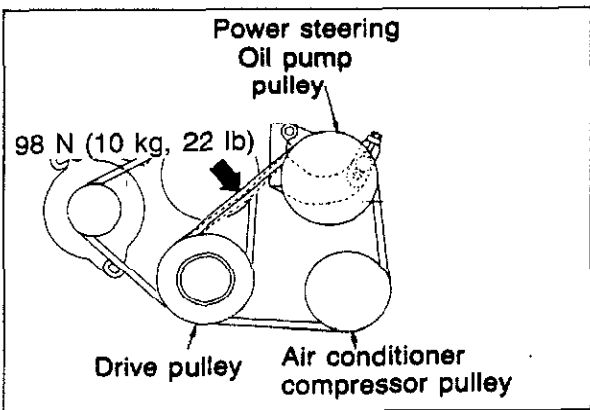

83U01A-010

A/C and P/S oil pump drive belt

**New: 8—9 mm (0.31—0.35 in)**  
**Used: 9—10 mm (0.35—0.39 in)**

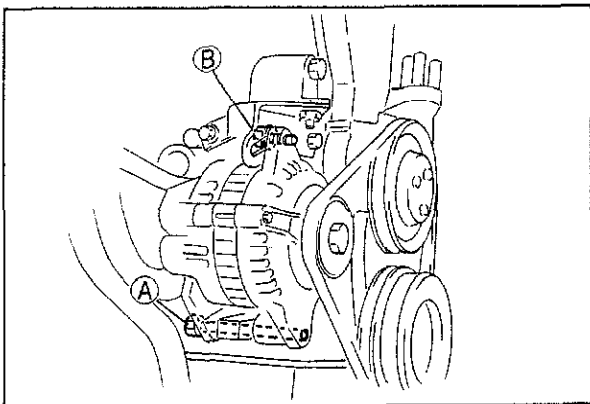

83U01A-011

### Adjustment of belt deflection

Alternator drive belt

1. Loosen the alternator mounting bolt A and adjusting bolt B.
2. Lever the alternator outward and apply tension to the belt.
3. Tighten the adjusting bolt B.

#### Tightening torque:

**19—26 N·m (1.9—2.6 m·kg, 14—19 ft·lb)**

4. Tighten the mounting bolt A.

#### Tightening torque:

**37—52 N·m (3.8—5.3 m·kg, 27—38 ft·lb)**

5. Recheck the belt tension or deflection.

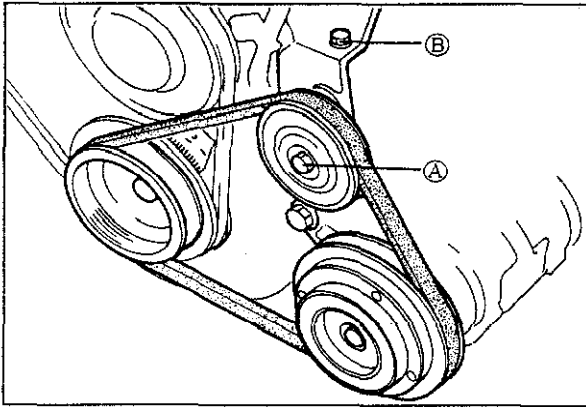

83U01A-012

### A/C drive belt

1. Loosen the idler pulley lock bolt A.
2. Adjust the belt tension and deflection by turning the adjusting bolt B.
3. Tighten the idler pulley lock bolt A.

### Tightening torque:

**31—46 N·m (3.2—4.7 m·kg, 24—34 ft·lb)**

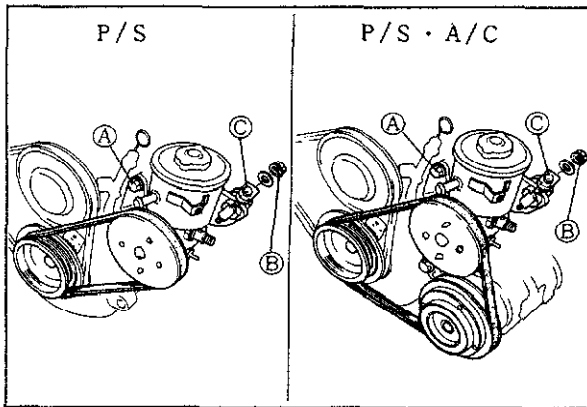

83U01A-013

### P/S oil pump drive belt, A/C and P/S oil pump drive belt

1. Loosen the mounting bolt A and adjusting bolt lock nut B.
2. Adjust the belt tension and deflection by turning the adjusting bolt C.
3. Tighten the adjusting bolt lock nut B and mounting bolt A.

### Tightening torque:

**Bolt A: 31—46 N·m**

**(3.2—4.7 m·kg, 24—34 ft·lb)**

**Nut B: 36—54 N·m**

**(3.7—5.5 m·kg, 27—40 ft·lb)**

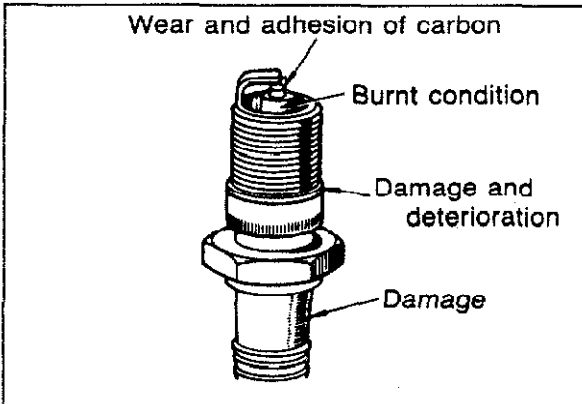

63U01X-010

### Spark Plug

Check the following points, clean or replace if necessary.

1. Damaged insulation
2. Worn electrodes
3. Carbon deposits
4. Damaged gasket
5. Burnt spark insulator
6. Plug gap

### Standard plug gap:

**1.00—1.10 mm (0.039—0.043 in)**

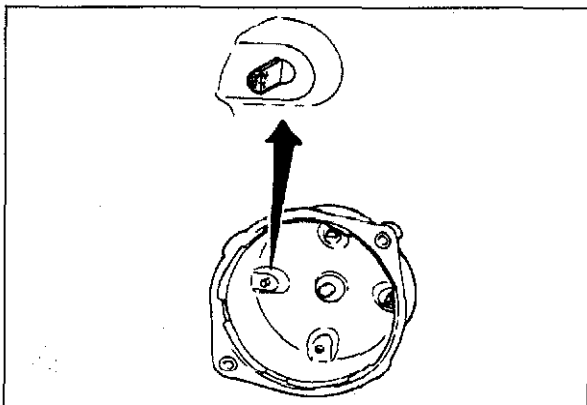

4BG01A-075

### Distributor Cap

Check the following points. If necessary, replace the distributor cap.

1. Cracks, carbon deposits
2. Burnt or corroded terminals
3. Worn distributor center contact

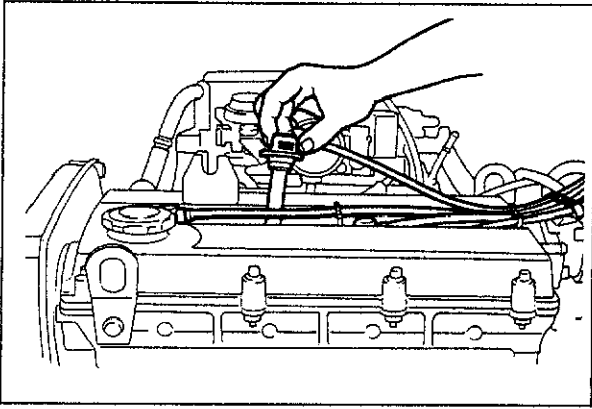

4BG01A-016

## High-tension Lead

Check the following points, if necessary clean or replace.

1. Damaged lead
2. Carbon deposits

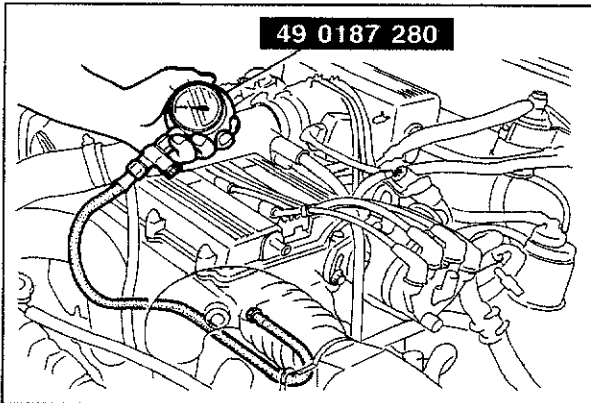

83U01B-005

## Hydraulic Lash Adjuster

### Note

**Tapet noise may occur if the engine is not operated for an extended period of time. The noise should disappear after the engine has reached normal operating temperature.**

1. Check for tappet noise, if noise exists, check the followings:
  - (1) Engine oil condition and level
  - (2) Cylinder head oil pressure (Refer to section 2B)

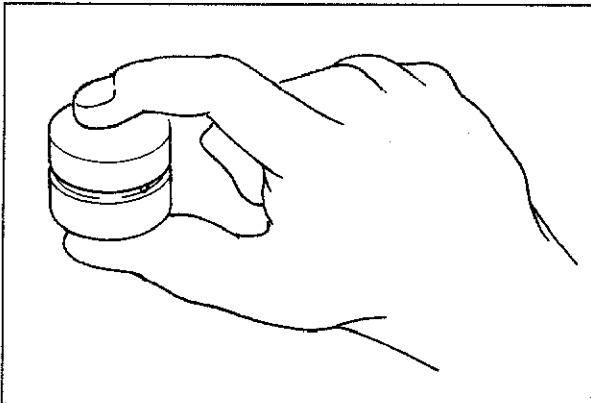

83U01B-006

2. If the noise does not disappear, check for movement of the HLA by pushing it during disassembly.
3. If the HLA moves, replace the HLA.

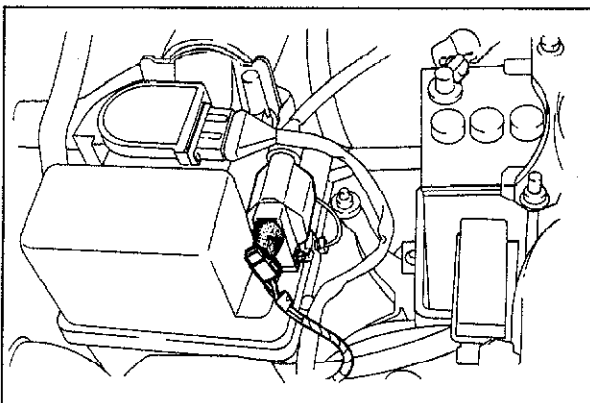

4BG01A-012

## Compression

1. Warm up the engine to operating temperature.
2. Turn it off for about 10 minutes to reduce the exhaust pipe temperature.
3. Remove all spark plugs.
4. Disconnect the primary wire connector from the ignition coil.

# 1B TUNE-UP PROCEDURE

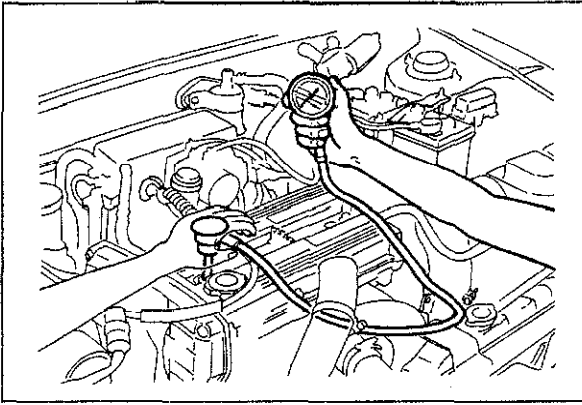

83U01B-007

5. Connect a compression gauge to the No. 1 spark plug hole.
6. Fully depress the accelerator pedal and crank the engine.
7. Check whether the gauge reads within the limits.

### Standard compression:

**1,079 kPa (11.0 kg/cm<sup>2</sup>, 156 psi)**

### Compression limit:

**755 kPa (7.7 kg/cm<sup>2</sup>, 109 psi)**

8. Check each cylinder.
9. Refit the primary wire connector securely to the ignition coil.
10. Install the spark plugs and high-tension leads.

### Ignition Timing

1. Warm up the engine and run it at idle.
2. Turn all electric loads OFF.
3. Connect a timing light tester.
4. Disconnect the vacuum hose from the vacuum control, and plug the hose.
5. Disconnect the black connector at distributor.
6. Check that the ignition timing mark (yellow) on the crankshaft pulley and the timing mark on the timing belt cover are aligned.

**Ignition timing: 12° ± 1° BTDC**

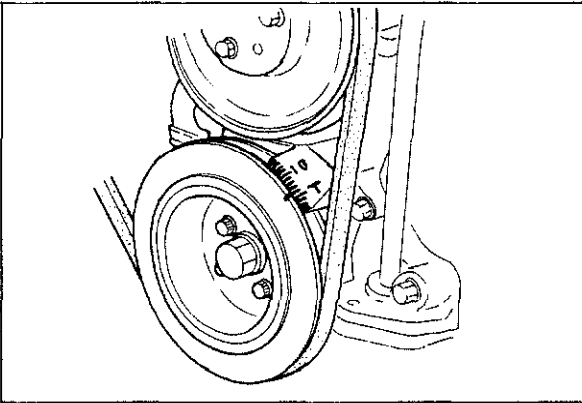

83U01B-008

7. If necessary, adjust the ignition timing by turning the distributor.
8. Reconnect the vacuum hose and the black connector at distributor.

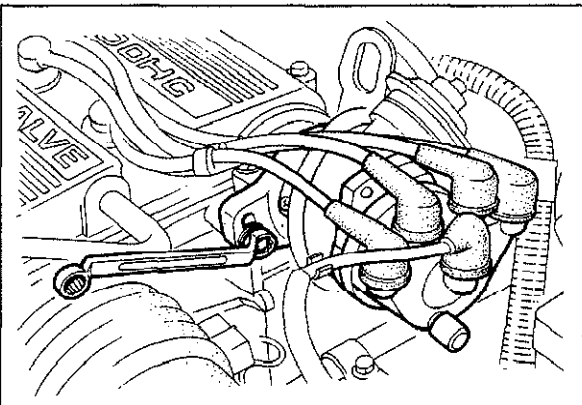

83U01A-018

### Idle Speed

1. Connect a tachometer to the engine.
2. Turn off all lights and other unnecessary electrical loads.
3. Check the idle speed. If necessary, turn the air adjust screw and adjust to specifications.

**Idle speed: 850 ± 50 rpm**

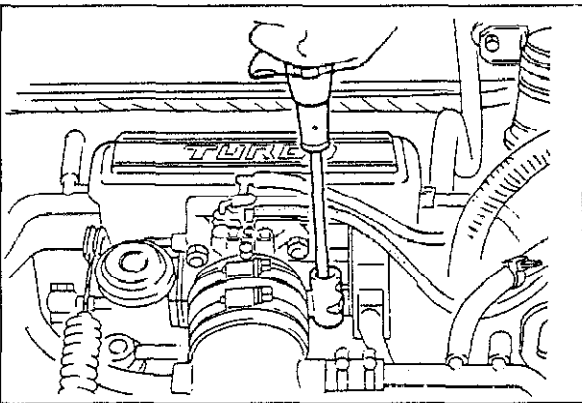

83U01B-009

## ON-VEHICLE MAINTENANCE

### TIMING BELT

#### Removal

1. Disconnect the battery negative cable.
2. Remove the parts in the numbered sequence shown in the figure.

83U01A-020

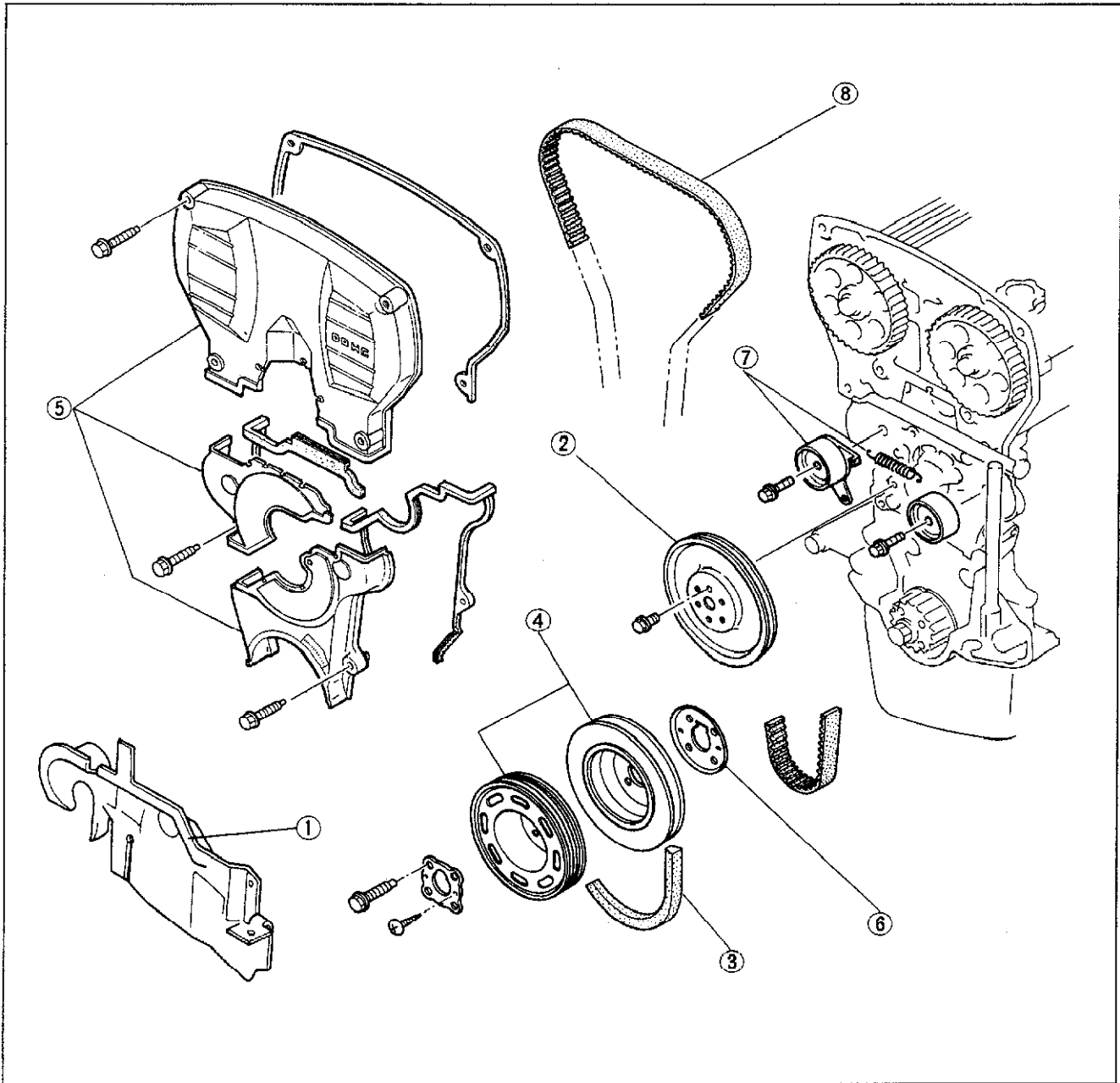

83U01B-010

- |  |   |
|--|---|
| <ol style="list-style-type: none"> <li>1. Side cover</li> <li>2. Water pump pulley</li> <li>3. Drive belt</li> <li>4. Crankshaft pulley</li> </ol> | <ol style="list-style-type: none"> <li>5. Timing belt cover (upper, middle, lower)</li> <li>6. Baffle plate</li> <li>7. Timing belt tensioner and spring</li> <li>8. Timing belt</li> </ol> |
|--|---|

#### Note

**Remove the No. 3 engine mount installation nuts and lower the engine to remove the A/C and P/S pulley and the crankshaft pulley.**



# 1B ON-VEHICLE MAINTENANCE (TIMING BELT)

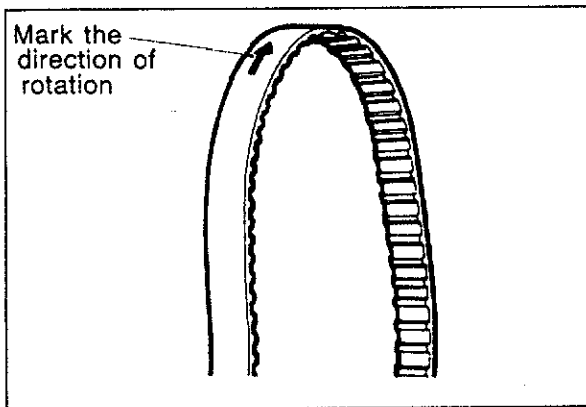

83U01B-108

1. Mark the direction of rotation on the timing belt.

### Note

The direction arrow is so the belt can be reinstalled in the same direction.

2. Remove the timing belt.

### Caution

Do not allow any oil or grease on the timing belt.

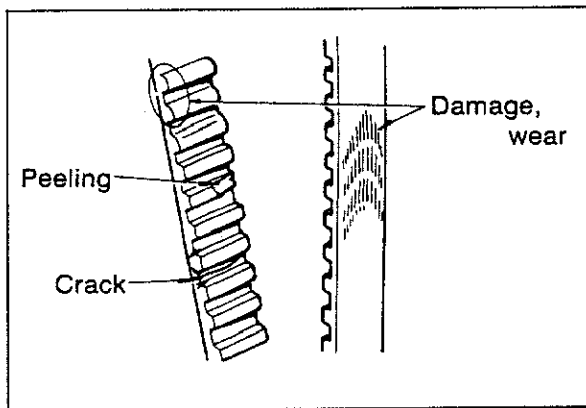

83U01B-011

### Inspection

Referring to page 1B—49, inspect the following parts:

1. Timing belt
2. Timing belt tensioner and spring
3. Timing belt pulley
4. Camshaft pulley

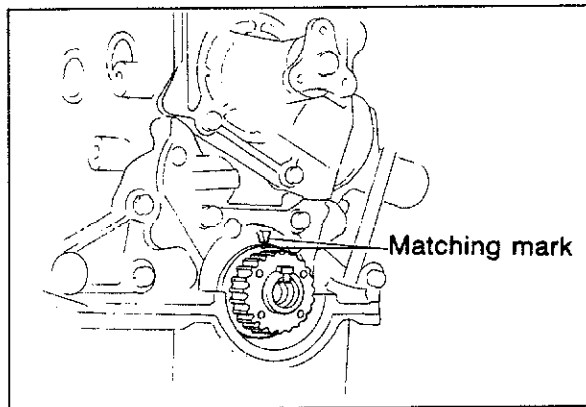

4BG01A-031

### Installation

1. Be sure that the timing mark on the timing belt pulley is aligned with the matching mark.

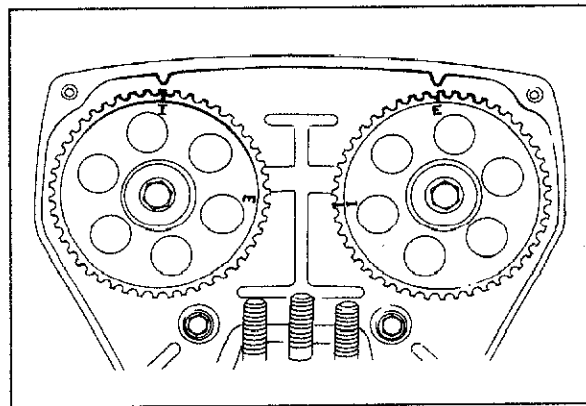

63G01C-012

2. Be sure that the matching mark on the camshaft pulley is aligned with seal plate matching mark. If it is not aligned, turn the camshaft to align.

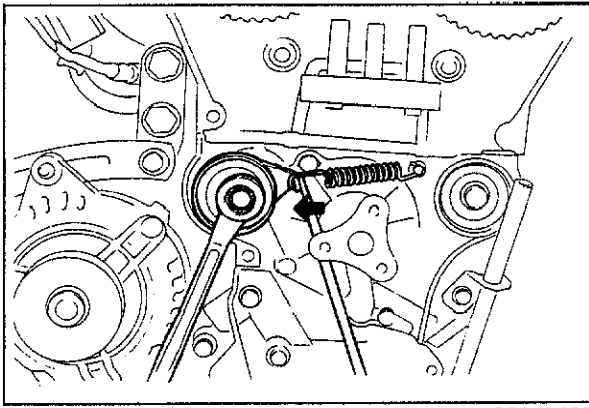

4BG01A-033

3. Install the timing belt tensioner and spring. Temporarily secure it so the spring is fully extended.

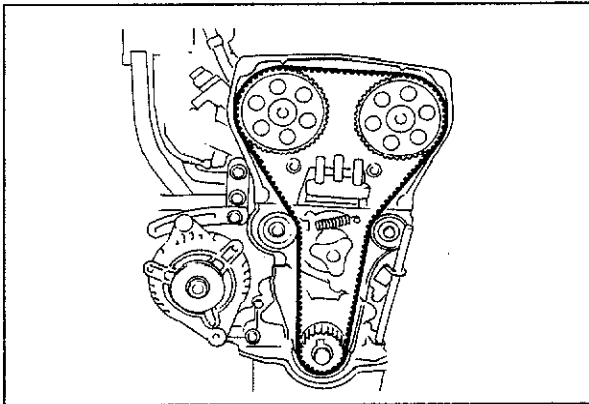

83U01A-109

4. Install the timing belt. (keep the right side of belt as tight as possible)

**Caution**

- a) The timing belt must be reinstalled in the same direction of previous rotation if it is reused.
- b) Be sure that there is no oil, grease, or dirt on the timing belt.

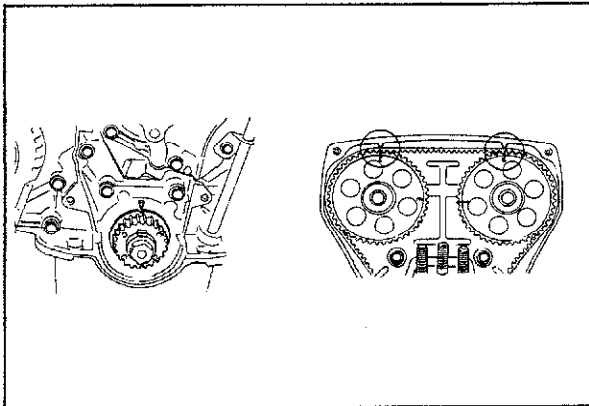

83U01A-110

**Note**

**Remove all spark plugs for easier rotation.**

5. Turn the crankshaft twice in the direction of rotation. (Clockwise)
6. Check that the timing marks are correctly aligned. If not repeat steps 1—5.
7. Loosen the tensioner lock bolt and apply tension to the belt.

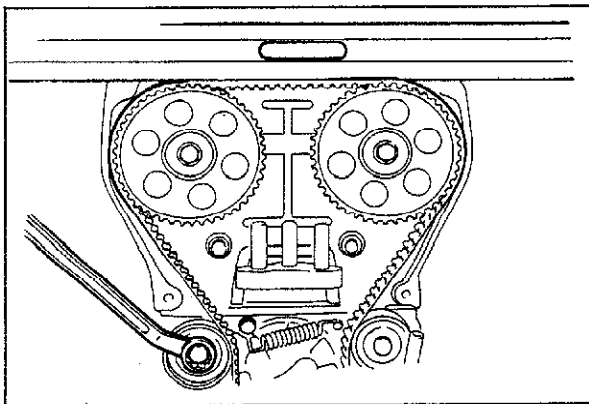

63U01X-024p

8. Tighten the timing belt tensioner lock bolt.

**Tightening torque:**

**37—52 N·m (3.8—5.3 m·kg, 27—38 ft·lb)**

9. Turn the crankshaft twice in the direction of rotation and check the matching marks for alignment.

# 1B ON-VEHICLE MAINTENANCE (TIMING BELT)

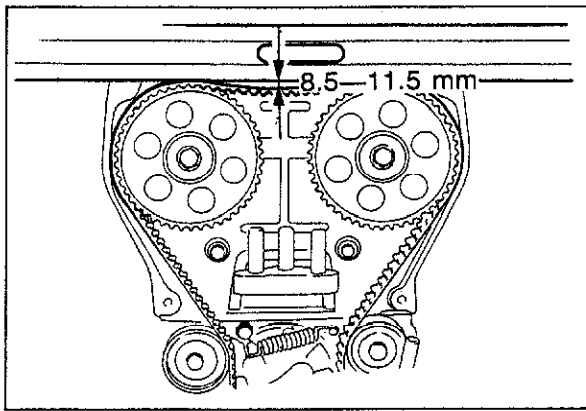

83U01B-012

10. Measure the tension between the intake side camshaft pulley and the exhaust side camshaft pulley. If the timing belt tension is not correct, loosen the tensioner lock bolt and repeat steps 3—9 above or replace the tensioner spring.

**Timing belt deflection:**

**8.5—11.5 mm (0.33—0.45 in)  
/ 98 N (10 kg, 22 lb)**

**Caution**

**Be sure not to apply tension other than that of the tensioner spring.**

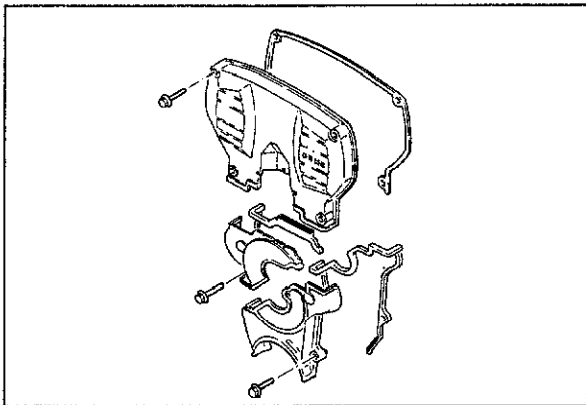

83U01A-111

11. Install the lower and upper timing belt cover.

**Tightening torque:**

**8—11 N·m (0.8—1.1 m·kg, 69—95 in·lb)**

12. Install the spark plugs.

**Tightening torque:**

**15—23 N·m (1.5—2.3 m·kg, 11—17 ft·lb)**

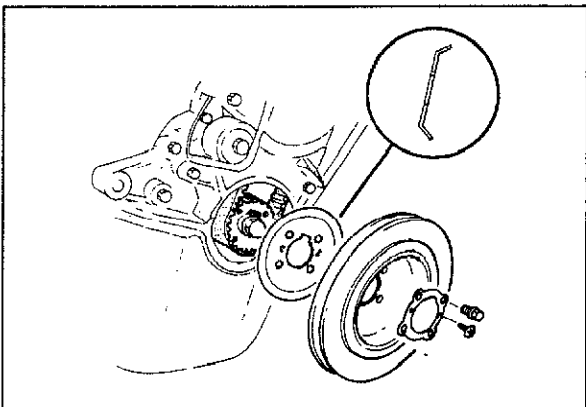

83U01B-013

13. Install the baffle plate and the crankshaft pulley.

**Tightening torque: 12—17 N·m**

**(1.25—1.75 m·kg, 109—152 in·lb)**

14. Install the No.3 engine mount bracket.

**Tightening torque:**

**60—85 N·m (6.1—8.7 m·kg, 44—63 ft·lb)**

15. Install the drive belt and adjust the belt tension (refer to page 1B—6).

16. Install the engine side cover.

17. Connect the battery negative cable.

## CYLINDER HEAD Removal

### Warning

Release the fuel pressure (Refer to FUEL PRESSURE RELEASE of FUEL SYSTEM section).

1. Disconnect the battery negative cable.
2. Drain the coolant.
3. Remove the parts in the numbered sequence shown in the figure.

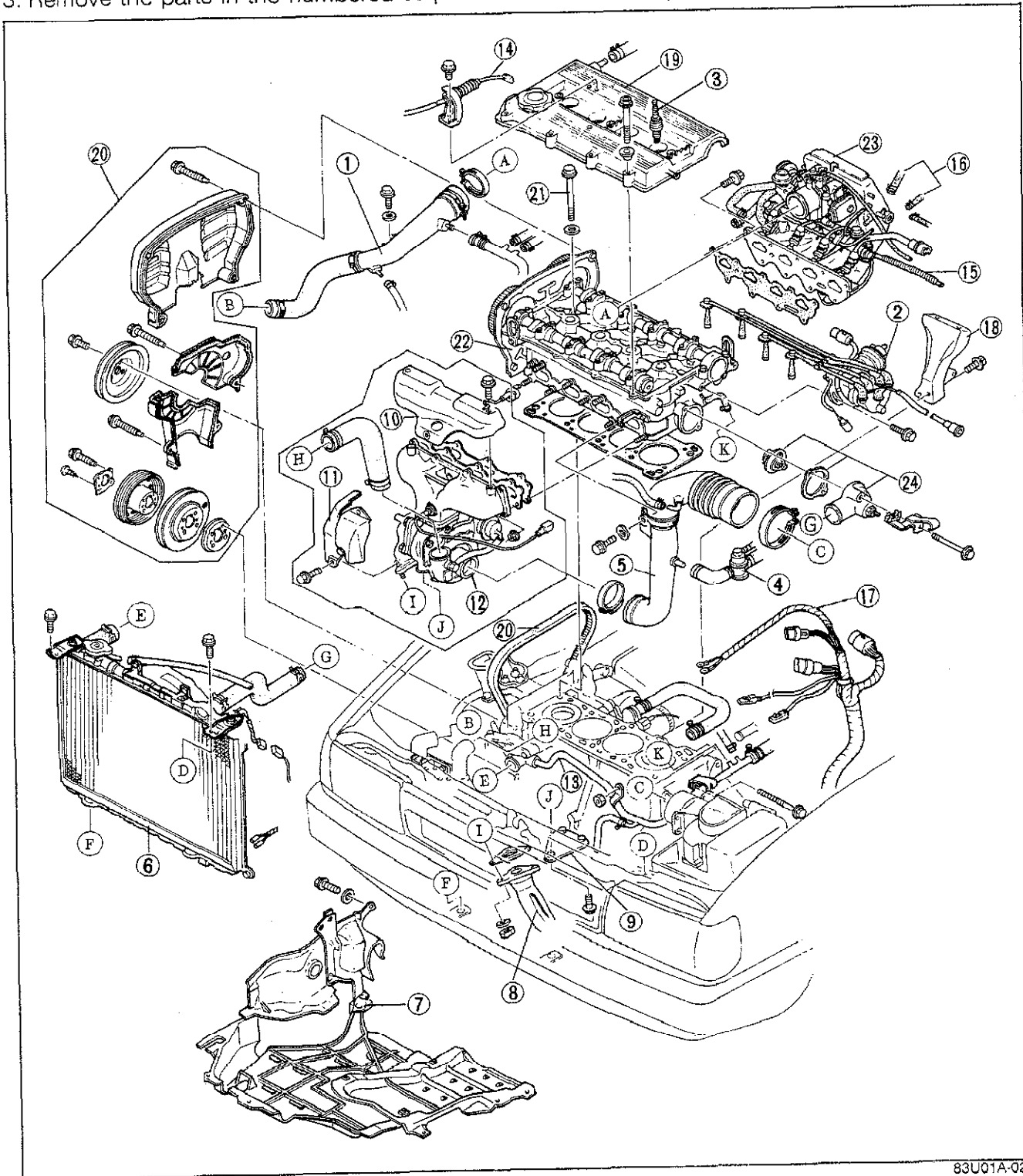

83U01A-025

# 1B ON-VEHICLE MAINTENANCE (CYLINDER HEAD)

1. Air intake pipe
2. Distributor and high-tension leads
3. Spark plugs
4. Air bypass valve and hoses assembly
5. Air pipe
6. Radiator (Refer to 3B—10)
7. Engine side cover and under cover
8. Exhaust pipe
9. Turbocharger bracket
10. Exhaust manifold insulator
11. Turbocharger insulator
12. Exhaust manifold and turbocharger assembly

13. Coolant bypass pipe
14. Accelerator cable
15. Fuel hoses
16. Vacuum hoses
17. Engine harness connectors
18. Surge tank bracket
19. Cylinder head cover
20. Timing belt (Refer to 1B—11)
21. Cylinder head bolts
22. Cylinder head and intake manifold assembly
23. Intake manifold assembly
24. Thermostat and thermostat cover

83U01B-014

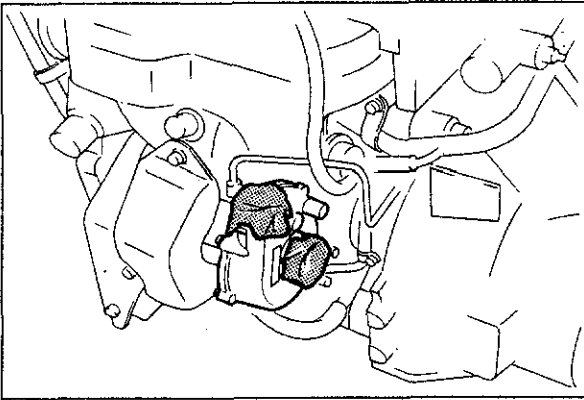

77U01X-017

## Turbocharger

Cover the intake and exhaust ports and oil passage to prevent dirt or other contaminants from entering.

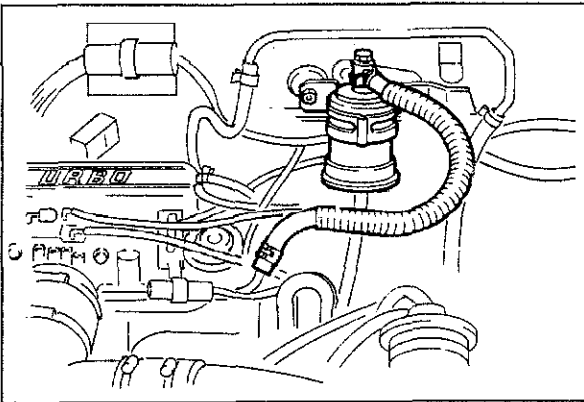

63G01C-104

## Fuel hose

After disconnecting the inlet and return fuel hoses, plug them.

## Warning

**Cover the hose with a rag because fuel will be splashed out when disconnecting the hose.**

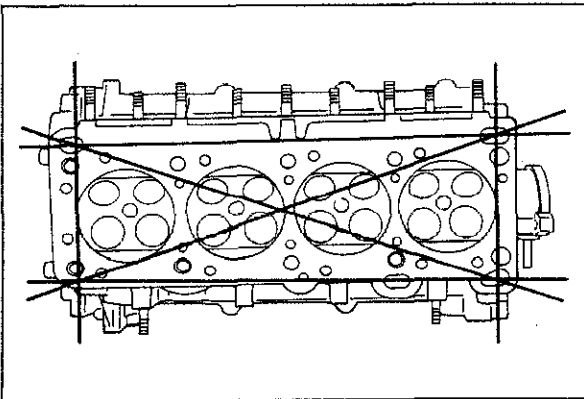

83U01B-015

## Disassembly of Cylinder Head

Refer to page 1B—30

## Inspection

Refer to page 1B—36

## Assembly

Refer to page 1B—59

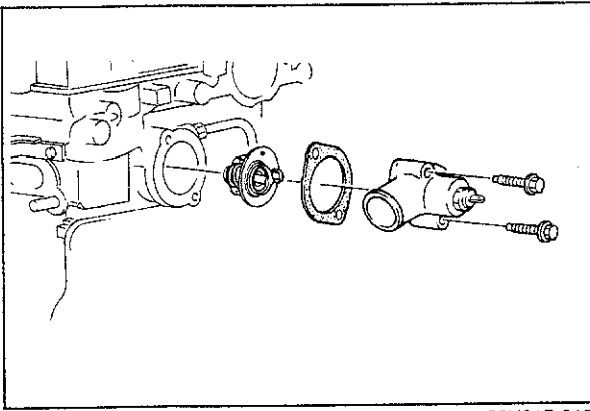

83U01B-016

### Installation

1. Install the thermostat with the jiggle pin facing upward.
2. Install the thermostat cover and gasket.

### Tightening torque:

**19—26 N·m (1.9—2.6 m·kg, 14—19 ft·lb)**

### Caution

**The printed side of the gasket must face the thermostat.**

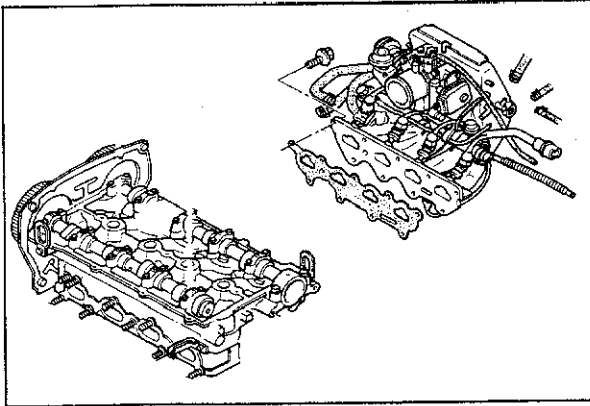

83U01B-017

3. Install the intake manifold assembly and new gasket.

### Tightening torque:

**19—26 N·m (1.9—2.6 m·kg, 14—19 ft·lb)**

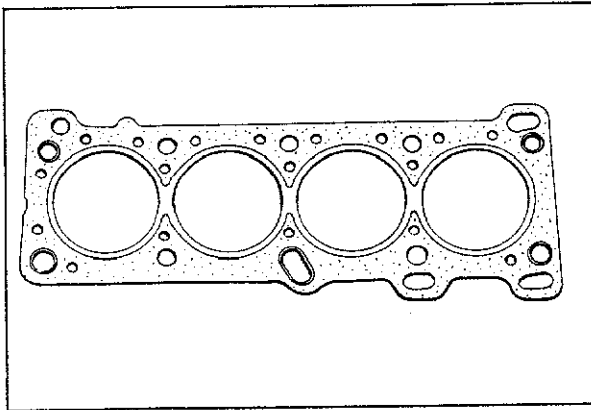

83U01B-018

4. Thoroughly remove all dirt and grease from the top of the cylinder block with a rag.
5. Place the new cylinder head gasket in position.

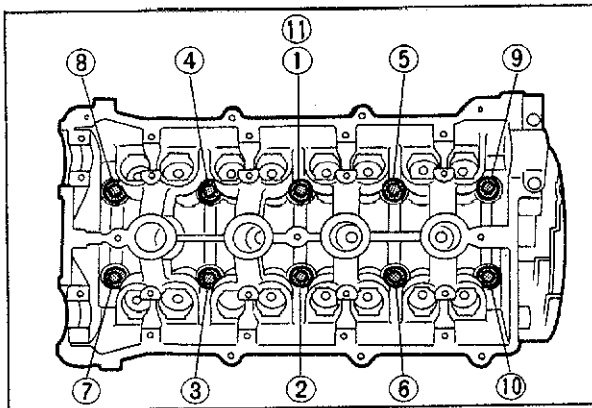

83U01B-019

6. Install the cylinder head, and tighten the cylinder head bolts gradually in the order shown in the figure.

### Tightening torque:

**76—81 N·m (7.7—8.3 m·kg, 56—60 ft·lb)**

# 1B ON-VEHICLE MAINTENANCE (CYLINDER HEAD)

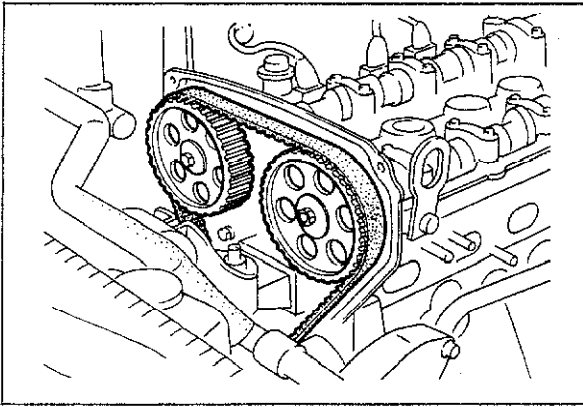

83U01B-020

7. Referring to the TIMING BELT section pages 1B—11 to 1B—14, install the timing belt.
8. Install the timing belt covers.

**Tightening torque:**

**8—11 N·m (0.8—1.1 m·kg, 69—95 in·lb)**

9. Install the water pump pulley.

**Tightening torque:**

**8—11 N·m (0.8—1.1 m·kg, 69—95 in·lb)**

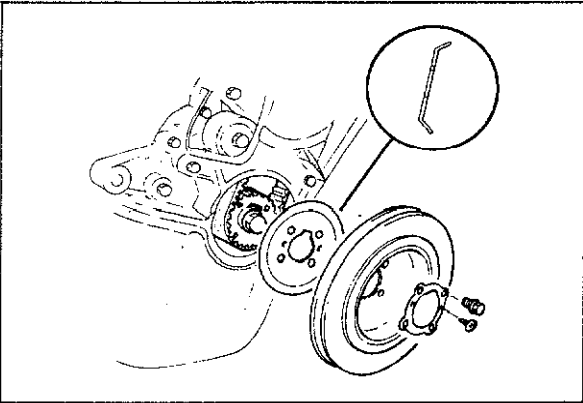

83U01B-021

10. Install the crankshaft pulley pulley and baffle plate.

**Tightening torque:**

**12—17 N·m (1.25—1.75 m·kg, 109—152 in·lb)**

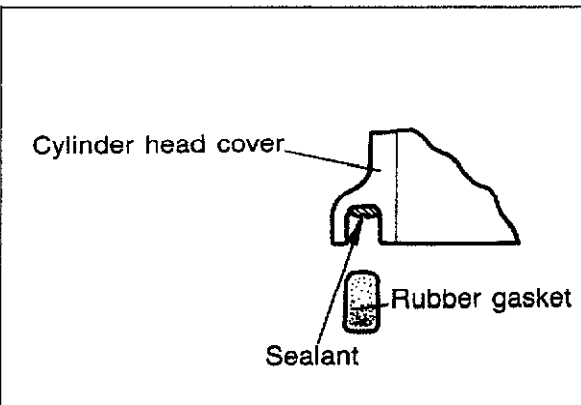

83U01B-022

11. Install the cylinder head cover.

- (1) Apply a coat of sealant to the cylinder head cover as shown in the figure.

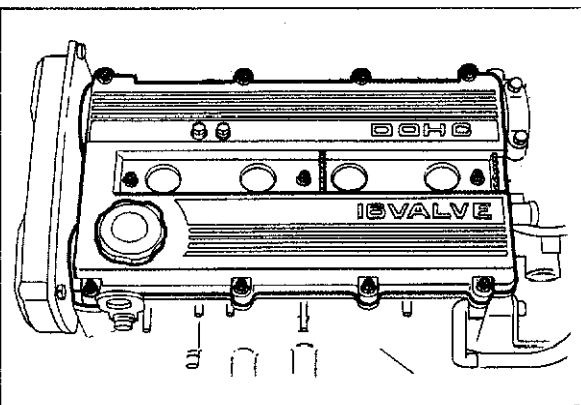

83U01B-023

- (2) Install the cylinder head cover.

**Tightening torque:**

**3—4 N·m (0.3—0.4 m·kg, 26—35 in·lb)**

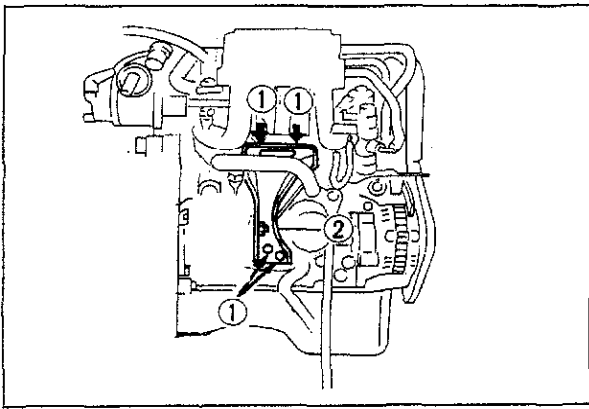

83U01B-024

12. Install the surge tank bracket.

**Tightening torque:**

**Bolt ①: 31—46 N·m**  
(3.2—4.7 m·kg, 23—34 ft·lb)

**Bolt ②: 19—26 N·m**  
(1.9—2.6 m·kg, 14—19 ft·lb)

13. Connect the engine harness connectors.  
14. Connect the vacuum hoses.  
15. Connect the Fuel hoses.  
16. Install the accelerator cable.

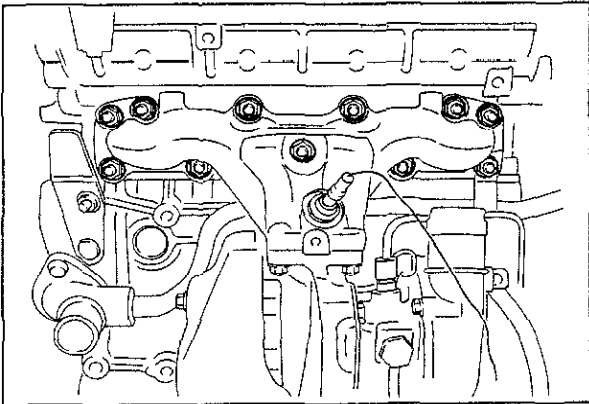

83U01B-025

17. Install the exhaust manifold and turbocharger assembly along with new gasket.

**Tightening torque:**

**39—57 N·m (4.0—5.8 m·kg, 29—42 ft·lb)**

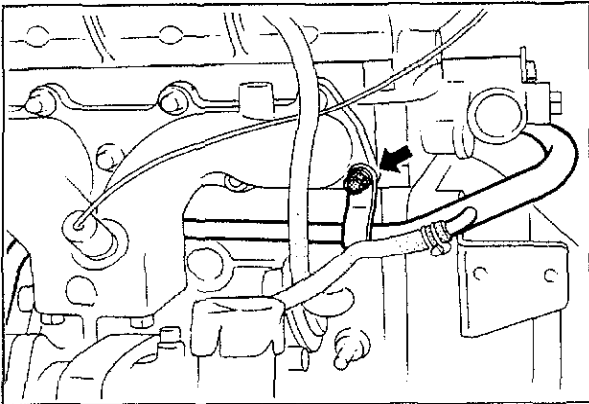

83U01B-026

18. Install the coolant bypass pipe bracket.

**Tightening torque:**

**39—57 N·m (4.0—5.8 m·kg, 29—42 ft·lb)**

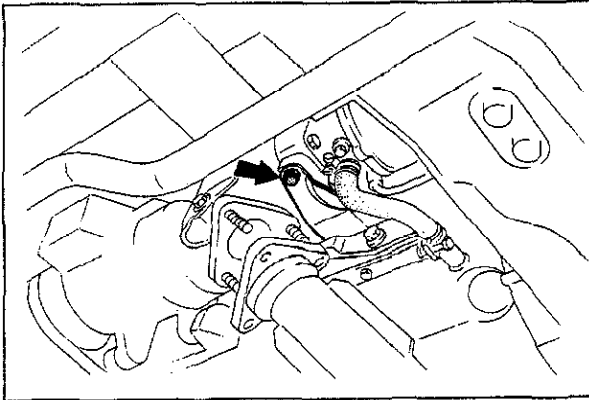

83U01B-027

19. Connect the turbocharger and turbocharger bracket.

**Tightening torque:**

**22—30 N·m (2.2—3.1 m·kg, 16—22 ft·lb)**



# 1B ON-VEHICLE MAINTENANCE (CYLINDER HEAD)

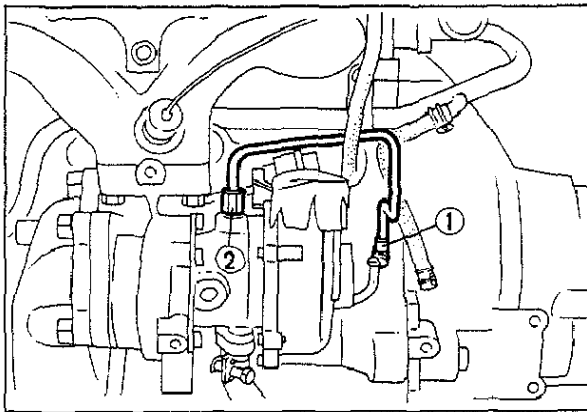

83U01B-028

20. Connect the oil pipe to the turbocharger and cylinder block.

**Tightening torque:**

**Bolt ①: 12—18 N·m  
(1.2—1.8 m·kg, 104—156 in·lb)**

**Nut ②: 16—24 N·m  
(1.6—2.4 m·kg, 12—17 ft·lb)**

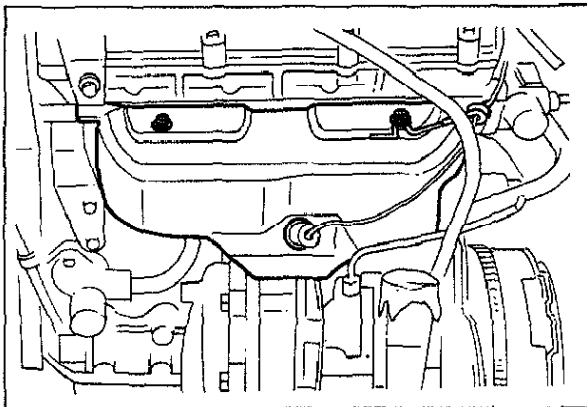

83U01B-029

21. Install the exhaust manifold insulator.

**Tightening torque:**

**19—26 N·m (1.9—2.6 m·kg, 14—19 ft·lb)**

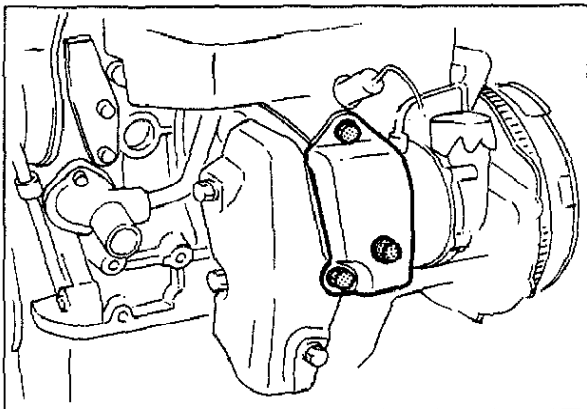

83U01B-030

22. Install the turbocharger insulator.

**Tightening torque:**

**19—26 N·m (1.9—2.6 m·kg, 14—19 ft·lb)**

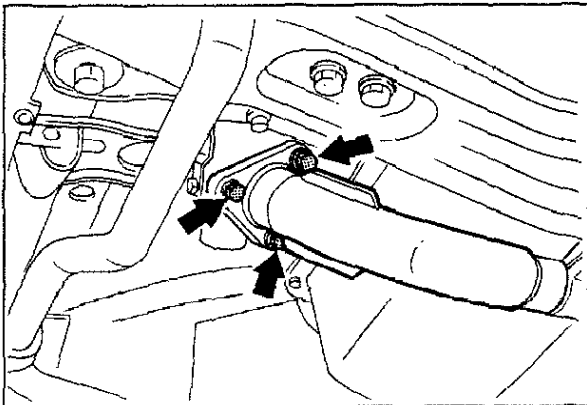

83U01B-031

23. Connect the exhaust pipe to the turbocharger.

**Tightening torque:**

**31—46 N·m (3.2—4.7 m·kg, 23—34 ft·lb)**

24. Install the engine side cover and under cover.  
25. Install the radiator. (Refer to 3B—10)

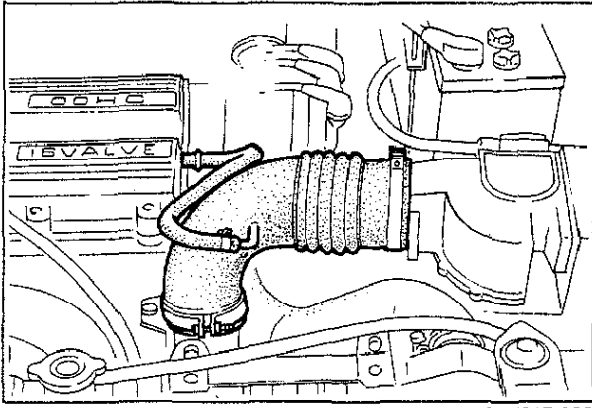

83U01B-032

26. Install the air pipe.
27. Install the air bypass valve and hoses assembly.

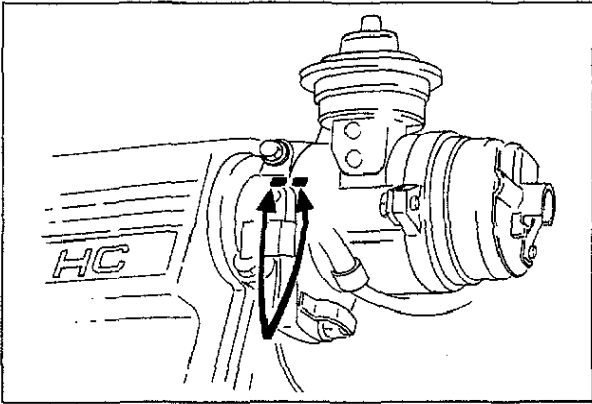

83U01B-033

28. Align the distributor blade with the grooved matching mark on the body, then install the distributor by referring to Section 5.
29. Install the spark plugs.

**Tightening torque:**

**15—23 N·m (1.5—2.3 m·kg, 11—17 ft·lb)**

30. Install the high-tension leads.

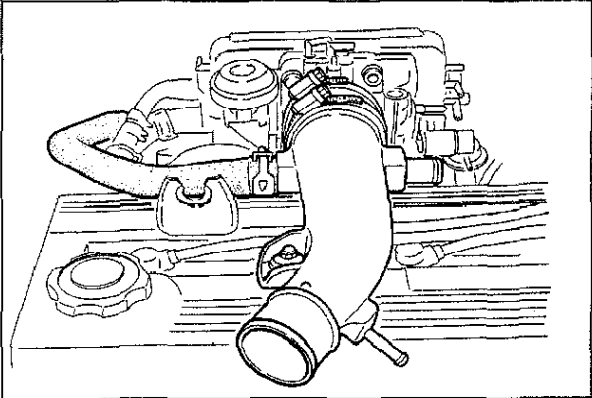

83U01B-034

31. Install the air intake pipe.
32. Fill the radiator with coolant.
33. Perform the necessary engine adjustments, refer to TUNE-UP PROCEDURE section.

# 1B REMOVAL AND INSTALLATION

## REMOVAL AND INSTALLATION

**Warning:** Release the fuel pressure (Refer to FUEL PRESSURE RELEASE of FUEL SYSTEM section).

1. Disconnect the battery negative cable.
2. Drain the engine oil, transaxle oil and coolant.
3. Remove the parts in the numbered sequence shown below.
4. Install in the reverse order of removal.

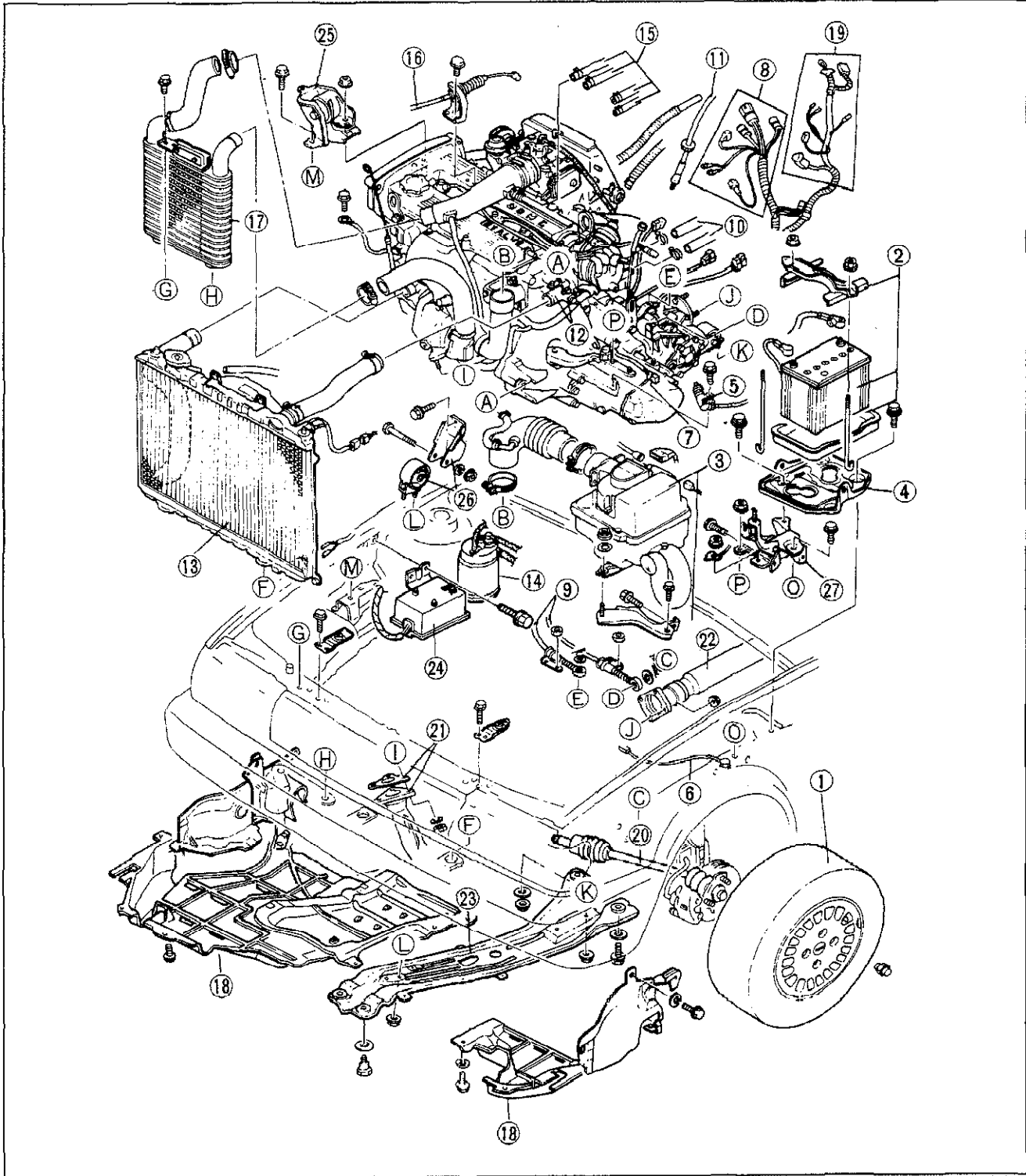

83U01A-043

- |                               |   |                                  |
|-------------------------------|---|----------------------------------|
| 1. Front wheels               | 12. Connectors (thermometer, electric fan switch)               | 20. Driveshafts                  |
| 2. Battery                    | 13. Radiator  | 21. Exhaust pipe                 |
| 3. Air cleaner                | 14. Canister hoses  | 22. Propeller shaft (for 4WD)    |
| 4. Battery carrier            | 15. Vacuum hoses  | 23. Engine mount member          |
| 5. Clutch release cylinder    | 16. Accelerator cable   | 24. Control unit                 |
| 6. Ground (body-transmission) | 17. Intercooler   | 25. No. 3 engine mount           |
| 7. Back up lamp connector     | 18. Under cover and side cover                                  | 26. No. 2 engine mount           |
| 8. Engine harness connectors  | 19. Connectors (starter motor, oil pressure switch, alternator) | 27. No. 4 engine mount (for 4WD) |
| 9. Shift control cables       |   |                                  |
| 10. Heater hoses              |   |                                  |
| 11. Speedometer cable         |   |                                  |

83U01B-035

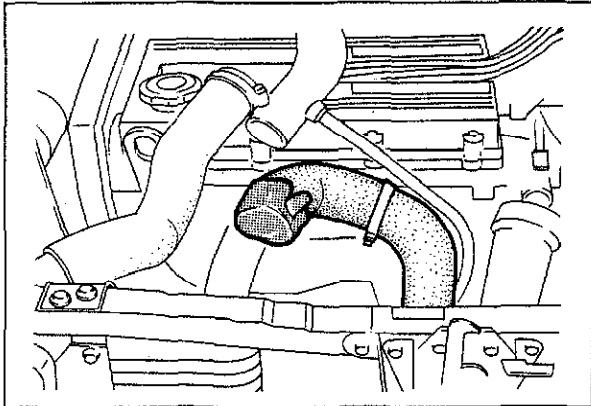

83U01B-036

### Intercooler

1. Disconnect the air hose from intercooler.

#### Caution

**Cover the end of air pipes and hoses with rag to prevent any foreign material from falling into the turbocharger or intake system.**

#### Note

**Do not insert screw driver or other between air hose and intercooler pipe, when disconnecting**

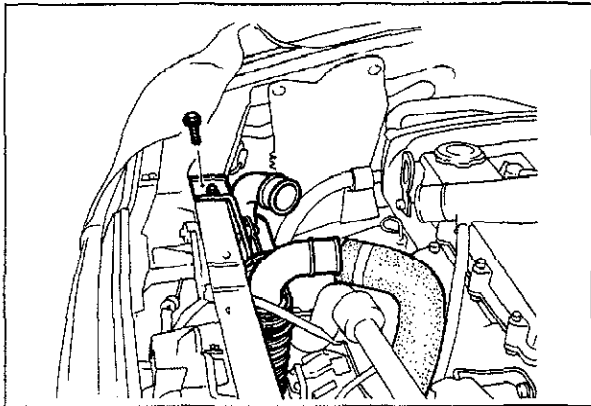

83U01B-037

2. Remove the intercooler

#### Note

**Be careful not to damage to the fins.**

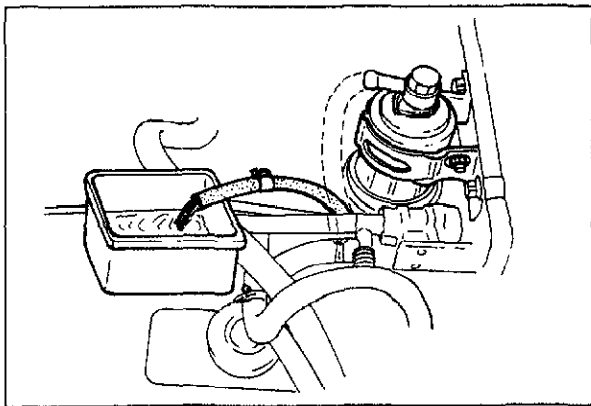

63G01C-108

### Fuel Hose

After disconnecting the fuel hoses (inlet and return), plug them to avoid fuel leakage.

#### Warning

**Keep sparks and open flame away from the fuel area.**

#### Caution

**When disconnect the hoses, cover the hoses with a rag since fuel will splash out.**

# 1B REMOVAL AND INSTALLATION

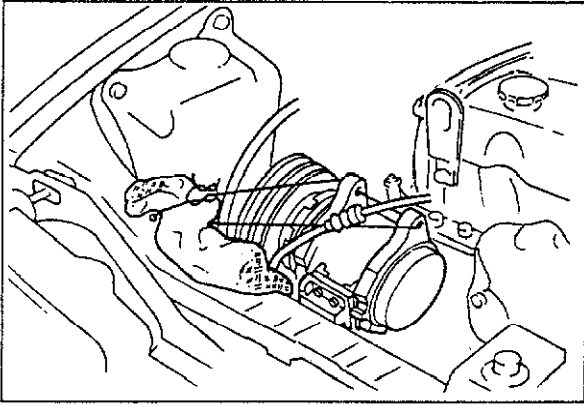

4BG01A-081

## A/C Compressor

Remove the compressor, and then, with the high-pressure and low-pressure hoses still connected to it, secure the compressor as shown in the figure.

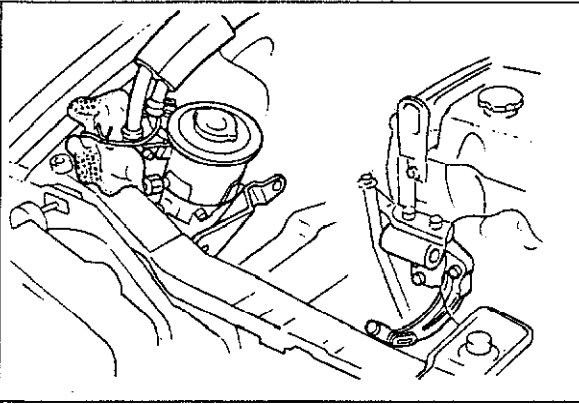

83U01A-045

## P/S Pump

Secure the P/S pump as shown in the figure. Be careful not to damage the pipe when the engine is removed and installed.

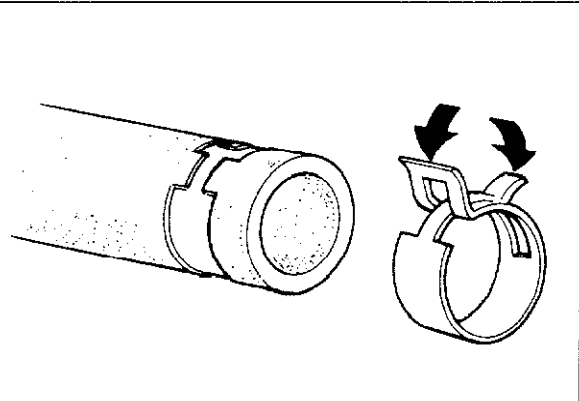

83U01A-046

## Hose Clamp

1. Position the hose clamp in the original location on the hose.
2. Squeeze the clamp lightly with large pliers to ensure a good fit.

## Engine Mount Torque Specification

After installing the engine into the engine room, tighten the engine mount bolts to the specified torque.

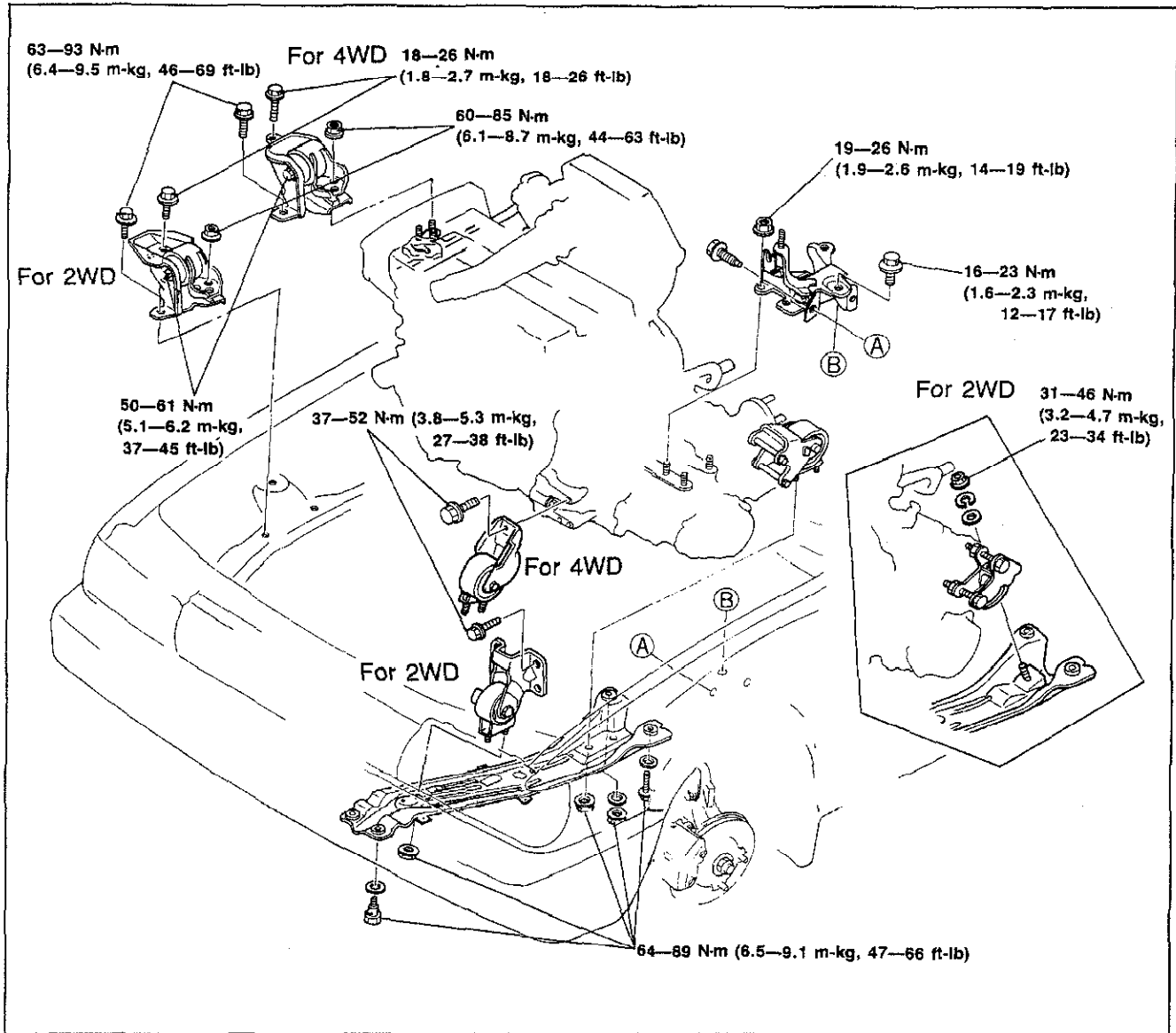

83U01A-046

### Steps After Installation

1. Adjust the drive belt tension. (Refer to 1B–6)
2. Fill the radiator and sub tank with coolant.
3. Fill the engine with engine oil.
4. Fill the transaxle with transaxle oil.

### Check Engine Condition

1. Check for leaks.
2. Perform engine adjustments as necessary.
3. Perform a road test.
4. Recheck the oil and coolant levels.

83U01B-038

# 1B DISASSEMBLY

## DISASSEMBLY

### Disassembly Note

1. Care should be taken during the disassembly of any part or system to study its order of assembly. Any deformation, wear, or damage also should be noted.
2. Code all identical parts (such as pistons, piston rings, connecting rods, and valve springs) so that they can be reinstalled in the position from which they were removed.
3. After steam cleaning the parts, use compressed air to blow off any remaining water.
4. Remove the parts in the order shown in the figure.

### Disassembly of Engine Auxiliary Parts

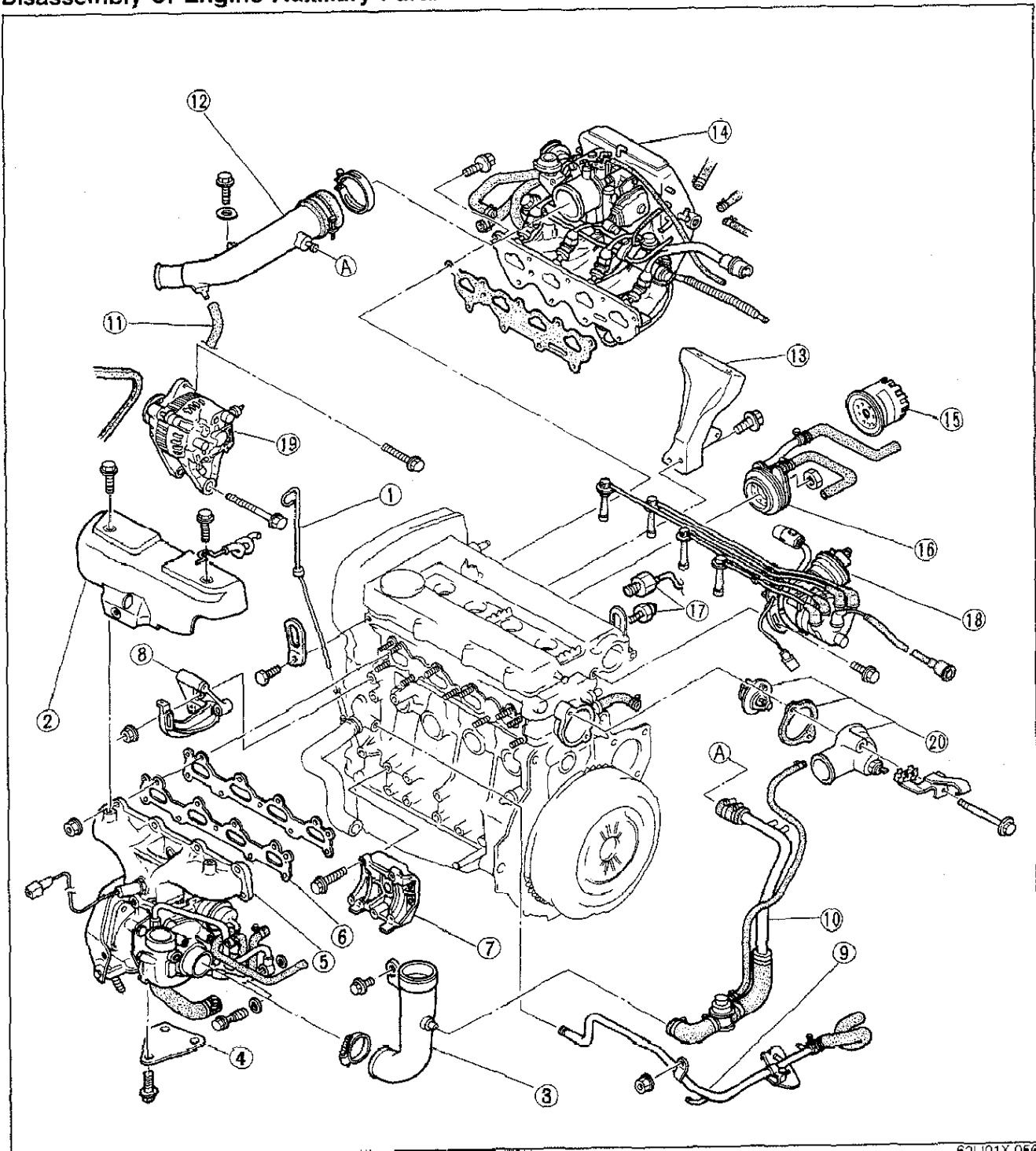

63U01X-056

1. Oil level gauge
2. Exhaust manifold insulator
3. Air hose
4. Turbocharger bracket
5. Exhaust manifold and turbocharger
6. Exhaust manifold gasket
7. A/C compressor bracket
8. P/S pump bracket
9. Coolant bypass pipe and hose
10. Air bypass valve and hoses
11. Hose
12. Air intake pipe
13. Surge tank bracket
14. Intake manifold assembly
15. Oil filter
16. Oil cooler
17. Oil pressure switch and knock sensor
18. Distributor and high-tension leads
19. Alternator and drive belt
20. Thermostat cover and thermostat

83U01B-039

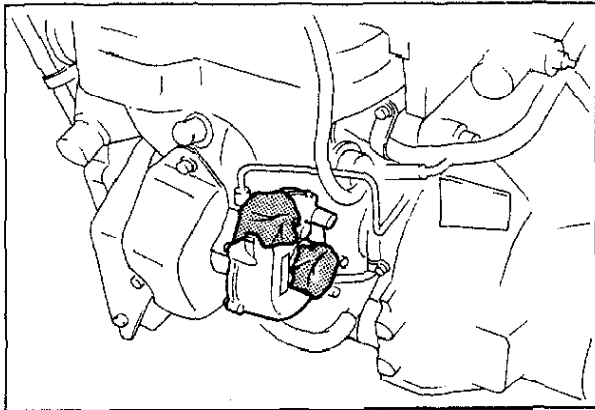

77U01X-017

### Turbocharger

Cover the intake and exhaust ports and oil passage to prevent dirt or other contaminants from entering.

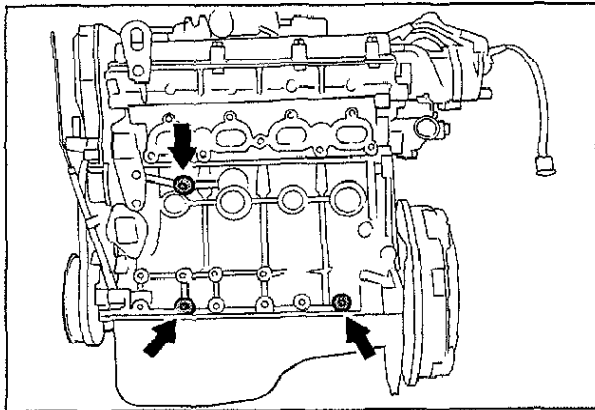

83U01X-123

### Engine hanger

After removing the exhaust manifold, install the engine on the **SST**.

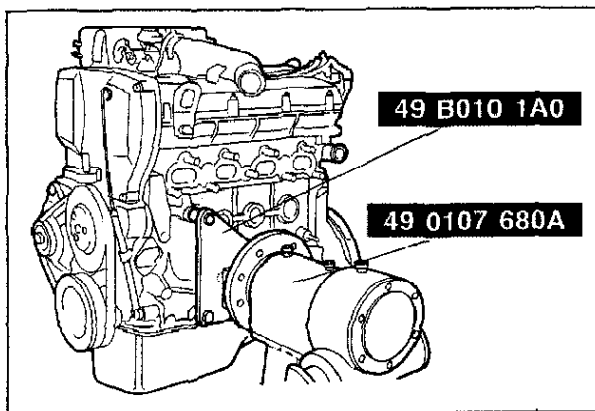

83U01A-049



# 1B DISASSEMBLY

## Disassembly of Front of Engine

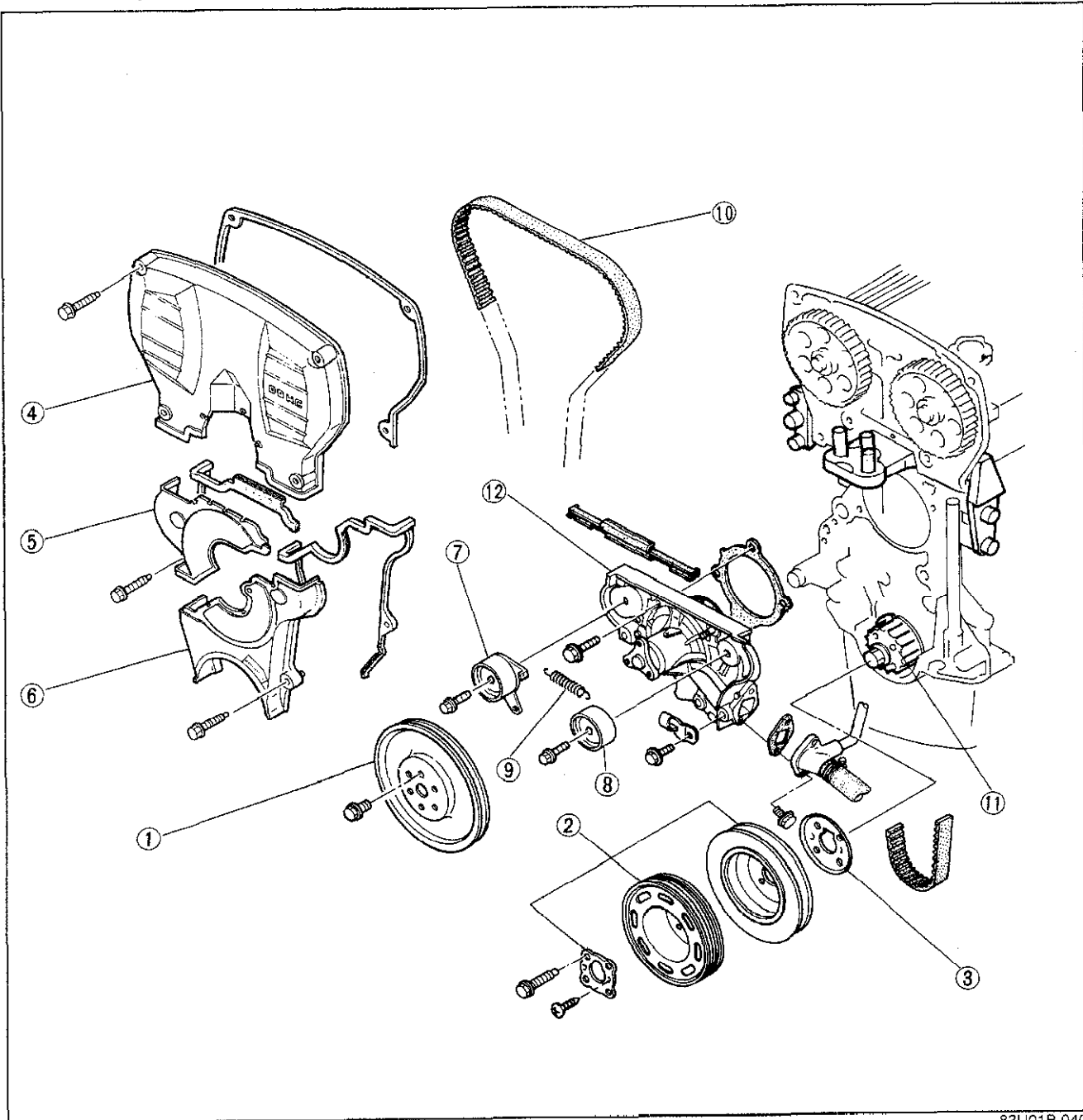

83U01B-040

- |                             |                              |
|-----------------------------|------------------------------|
| 1. Water pump pulley        | 7. Timing belt tensioner     |
| 2. Drive pulley             | 8. Idler pulley              |
| 3. Baffle plate             | 9. Tensioner spring          |
| 4. Upper timing belt cover  | 10. Timing belt              |
| 5. Middle timing belt cover | 11. Timing belt drive pulley |
| 6. Lower timing belt cover  | 12. Water pump               |

Mark the  
direction of  
rotation

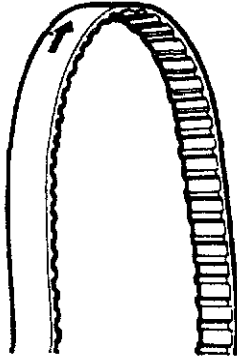

83U01A-112

### Timing belt

1. Remove the tensioner spring after loosening the tensioner lock bolt.
2. Mark the direction of rotation on the timing belt.
3. Remove the timing belt.

### Caution

**Do not allow any oil or grease on the timing belt.**

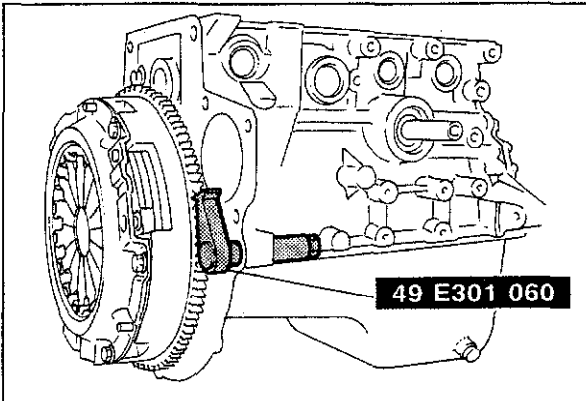

83U01X-124

### Crankshaft pulley and timing belt pulley

Set the **SST** to the flywheel. Remove the crankshaft pulley and the timing belt pulley.

# 1B DISASSEMBLY

## Disassembly Related to Cylinder Head

### Note

During disassembly, inspect the camshaft end play, camshaft bearing oil clearance referring to INSPECTION AND REPAIR section.

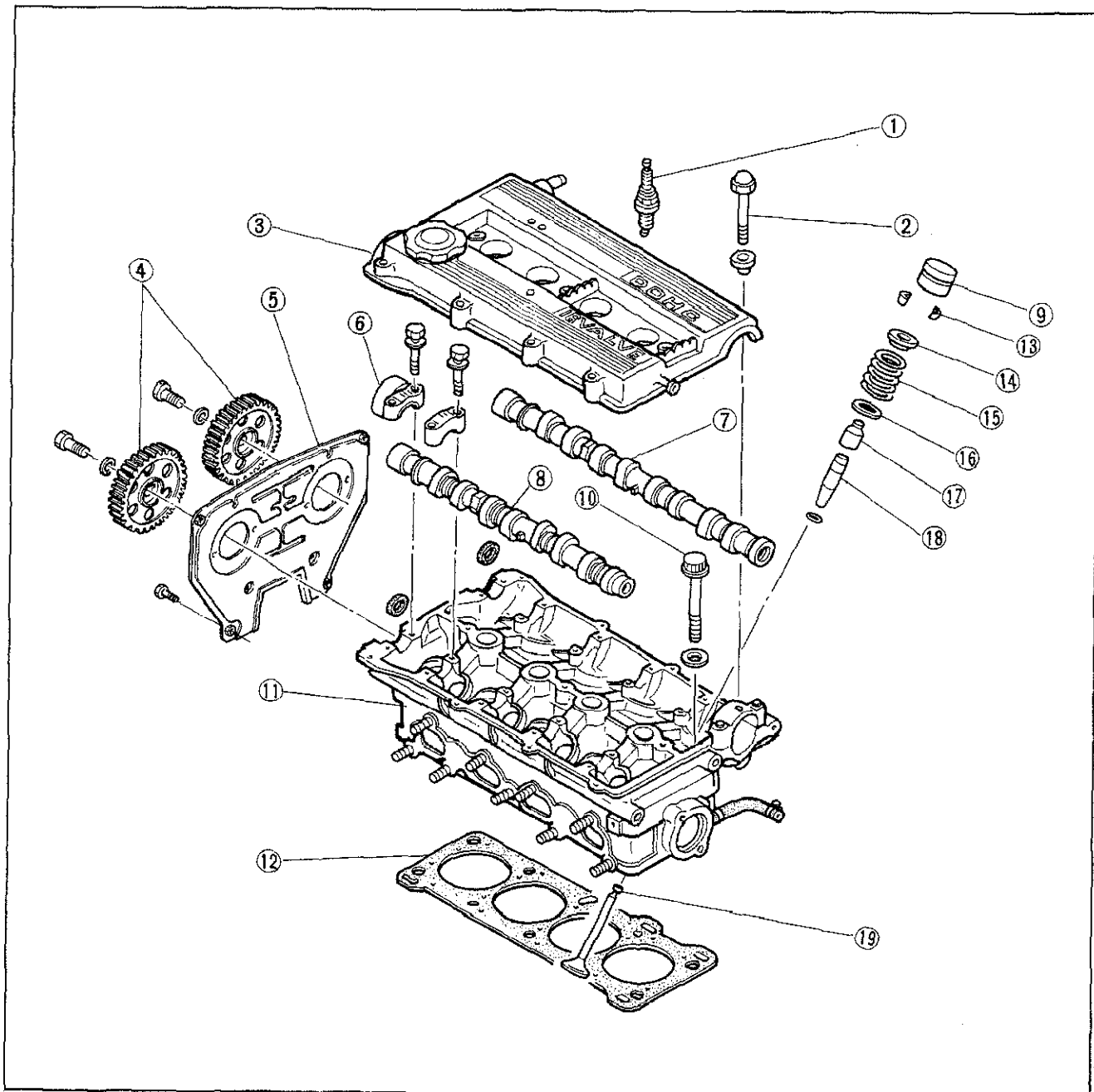

83U01B-041

- |                             |                               |
|-----------------------------|-------------------------------|
| 1. Spark plug               | 11. Cylinder head             |
| 2. Cylinder head cover bolt | 12. Cylinder head gasket      |
| 3. Cylinder head cover      | 13. Spring retainers          |
| 4. Camshaft pulley          | 14. Valve spring seat (upper) |
| 5. Seal plate               | 15. Valve spring              |
| 6. Camshaft cap             | 16. Valve spring seat (lower) |
| 7. Camshaft (IN)            | 17. Valve seal                |
| 8. Camshaft (EX)            | 18. Valve guide               |
| 9. Hydraulic lash adjuster  | 19. Valve                     |
| 10. Cylinder head bolts     |                               |

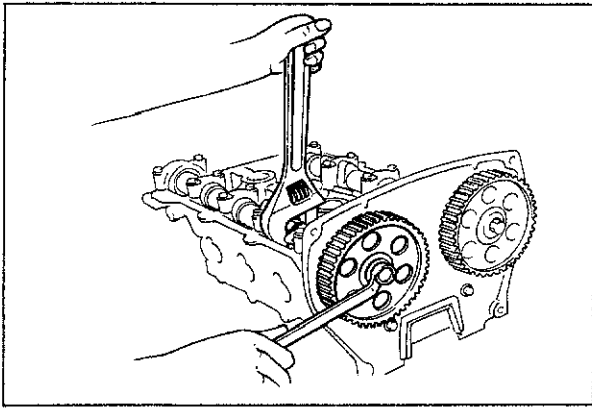

63G01C-039

### Camshaft pulley

Remove the pulley using a wrench to prevent it from turning.

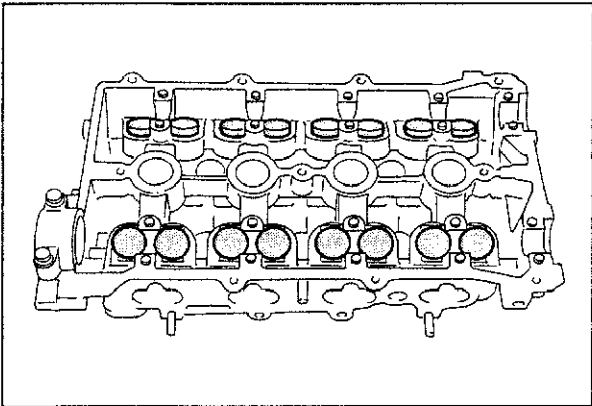

63G01C-041

### HLA (Hydraulic Lash Adjuster)

Remove the HLA from the cylinder head.

#### Note

Mark all HLA so that they can be reinstalled in the position from which they were removed.

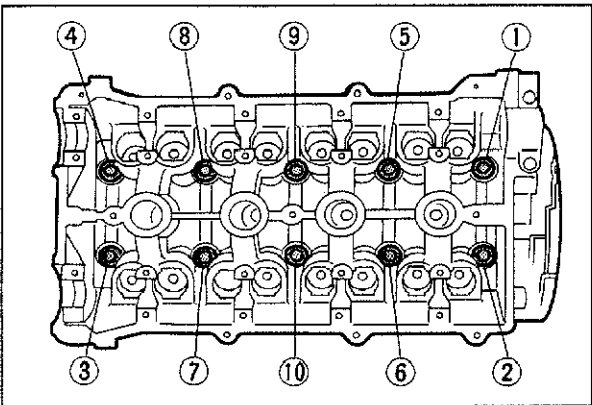

4BG01A-096

### Cylinder head bolt

Remove the cylinder head bolts in the numbered order shown in the figure. Loosen them gradually, in order.

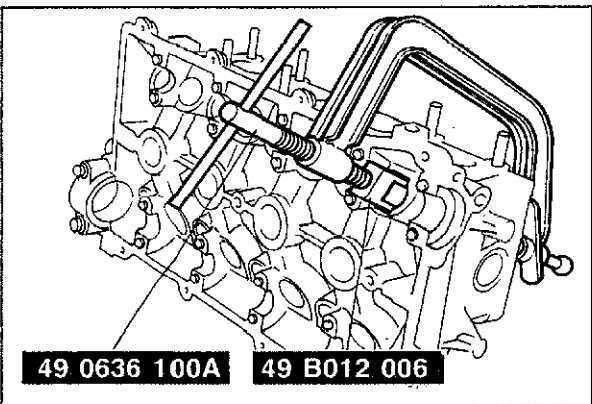

83U01B-042

### Valve

Remove the valves from the cylinder head with the SST.

# 1B DISASSEMBLY

## Disassembly Related to Lubrication System and Flywheel

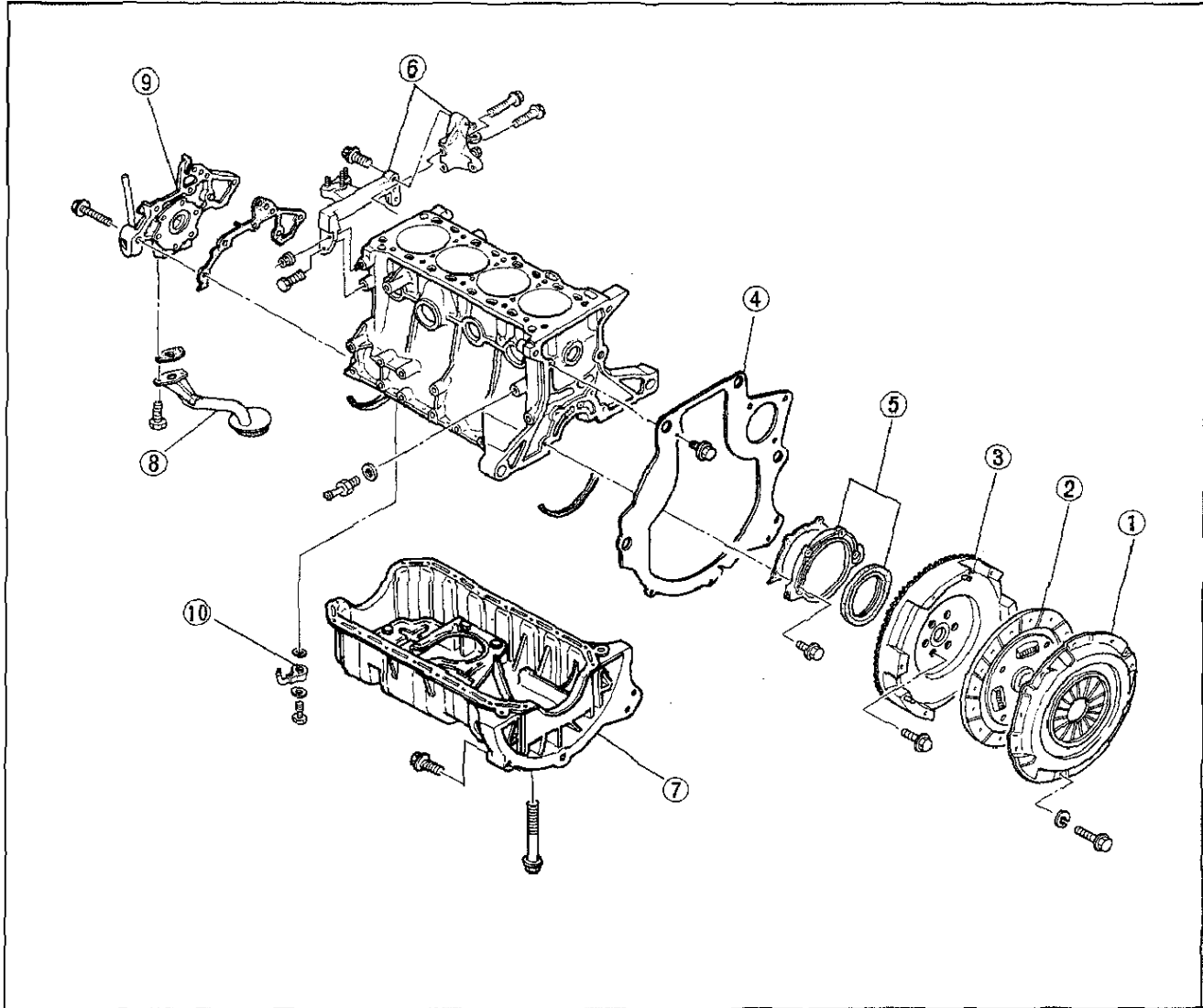

83U01B-043

- 1. Clutch cover
- 2. Clutch disc
- 3. Flywheel
- 4. End plate
- 5. Rear cover

- 6. Engine bracket and mount arm
- 7. Oil pan
- 8. Oil strainer
- 9. Oil pump
- 10. Oil jet

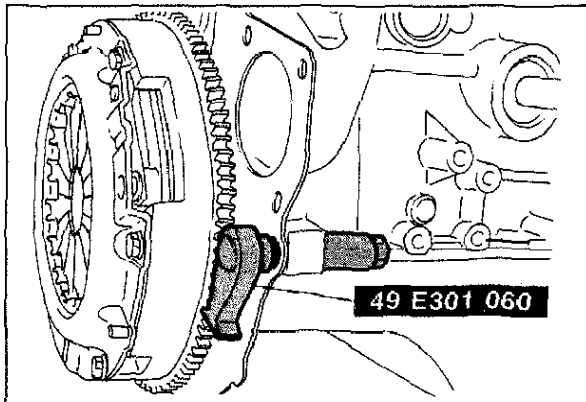

83U01X-125

### Clutch cover and flywheel

Remove the clutch cover and flywheel with the **SST** as shown in the figure.

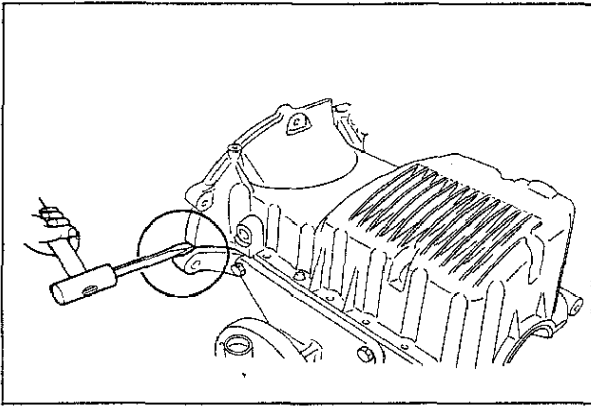

83U01B-044

## Oil pan

Remove the oil pan by prying only at the points shown in the figure.

### Caution

- a) Do not force a pry tool between the block and pan to prevent damaging the contact surfaces.
- b) Do not damage or scratch the contact surface when removing the oil sealant.

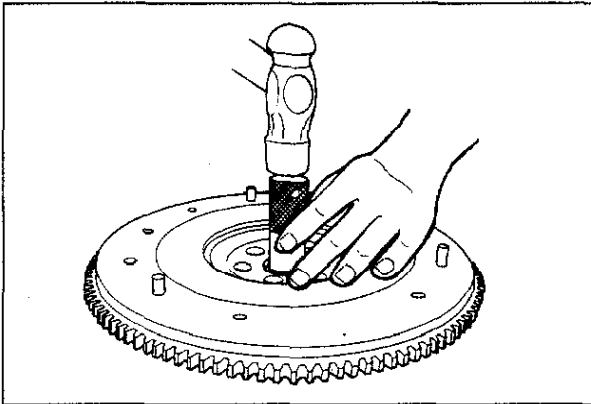

63U01X-065

## Flywheel pilot bearing

Use suitable pipe and punch out to the crankshaft side of the flywheel, as shown in the figure.

# 1B DISASSEMBLY

## Disassembly Related to Crankshaft and Piston

### Note

During disassembly, inspect the crankshaft end play, main journal bearing oil clearance, connecting rod bearing oil clearance, connecting rod side clearance referring to ASSEMBLY section.

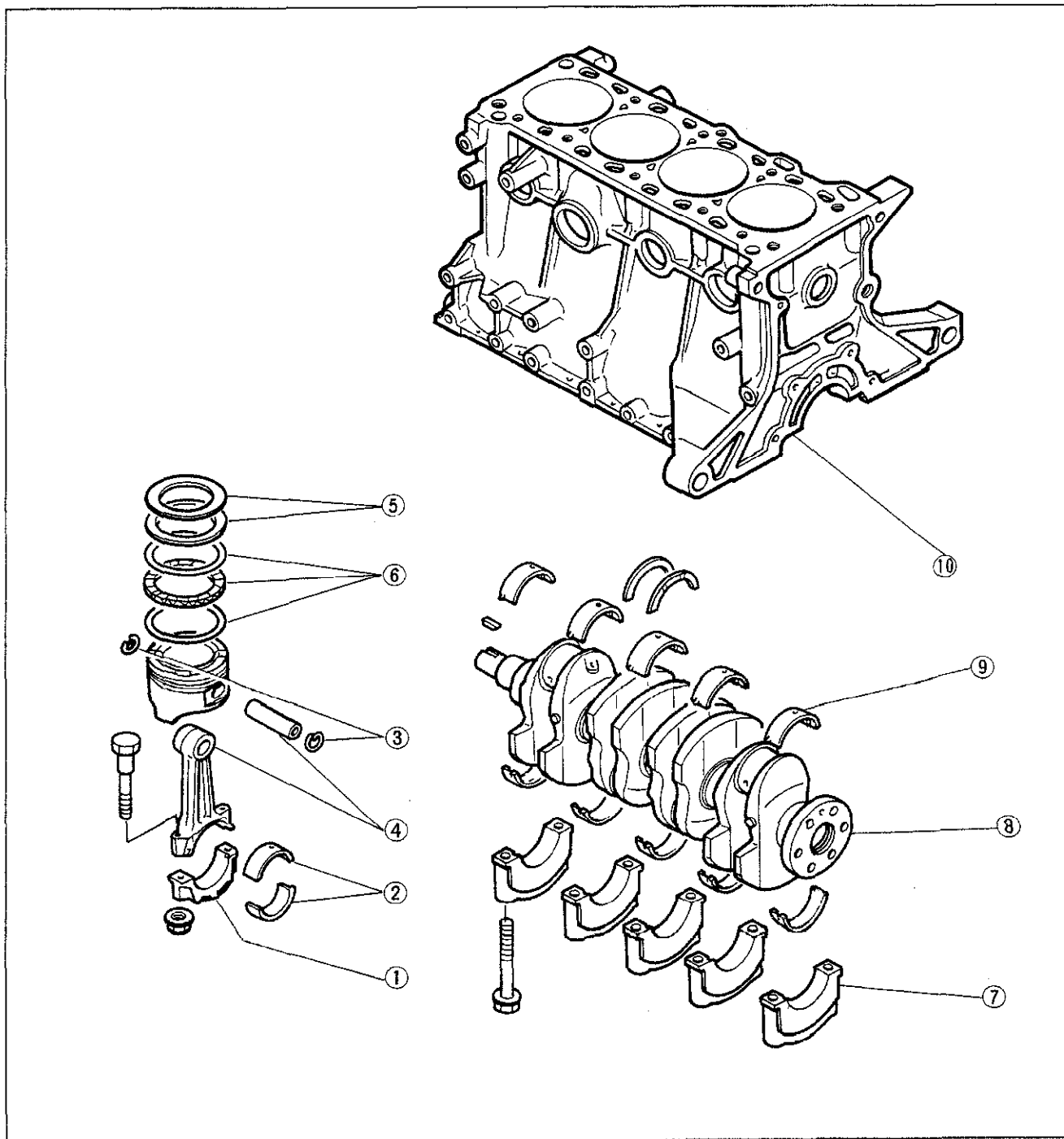

83U01B-045

1. Connecting rod caps
2. Connecting rod bearings
3. Clips
4. Connecting rod and piston pin
5. Piston rings

6. Oil rings
7. Main bearing caps
8. Crankshaft
9. Main bearings
10. Cylinder block

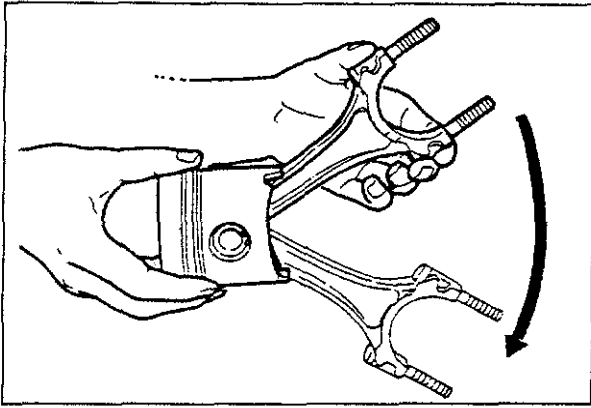

83U01B-046

## Piston and connecting rod

1. Check the oscillation torque of the connecting rod as shown in the figure. If the large end does not drop by its own weight, replace the piston and/or piston pin.

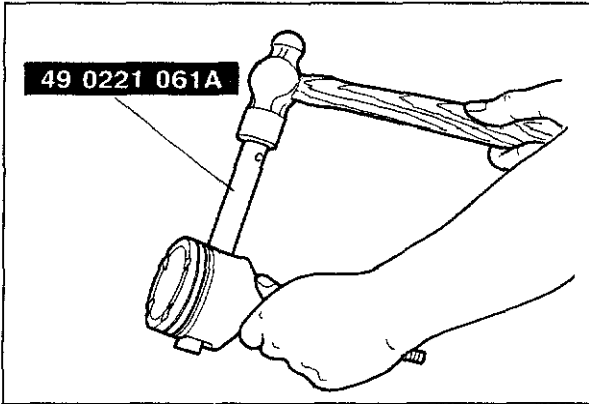

83U01A-054

2. Use the **SST** to remove the piston pin.



## INSPECTION AND REPAIR

1. Clean all parts, taking care to remove any gasket fragments, dirt, oil or grease, carbon, moisture residue, or other foreign material.
2. Inspect and repair in the order specified.

### Caution

**Be careful not to damage the joints or friction surfaces of aluminum alloy components such as the cylinder head or pistons.**

83U01A-058

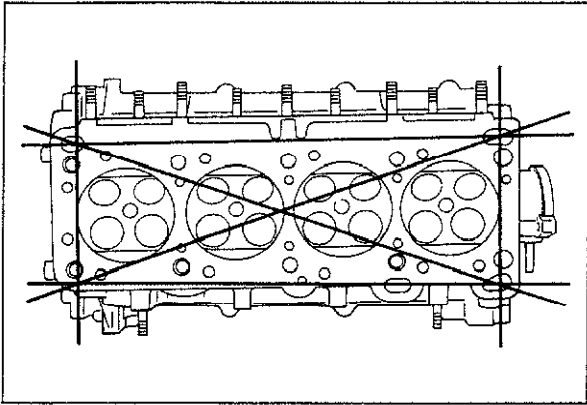

83U01A-059

### Cylinder Head

1. Inspect the cylinder head for damage, cracks, and leakage of water or oil, replace if necessary.
2. Measure the cylinder head distortion in the six directions shown in the figure.

**Distortion: 0.15 mm (0.006 in) max.**

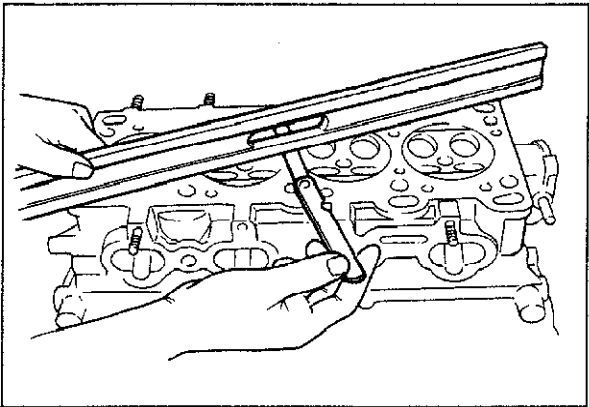

83U01B-047

3. If the cylinder head distortion exceeds specification, grind the cylinder head surface. If the cylinder head height is not within specification, replace it.

### Height:

**133.8—134.0 mm (5.268—5.276 in)**

**Grinding: 0.20 mm (0.008 in) max.**

### Note

**Before grinding the cylinder head, first check the following and replace the head if necessary.**

- Sinking of valve seat
- Distortion of manifold contact surface
- Camshaft oil clearance and end play

4. Measure the manifold contact surface distortion in the six directions shown in the figure.

**Distortion: 0.15 mm (0.006 in) max.**

5. If distortion exceeds specification, grind the surface or replace the cylinder head.

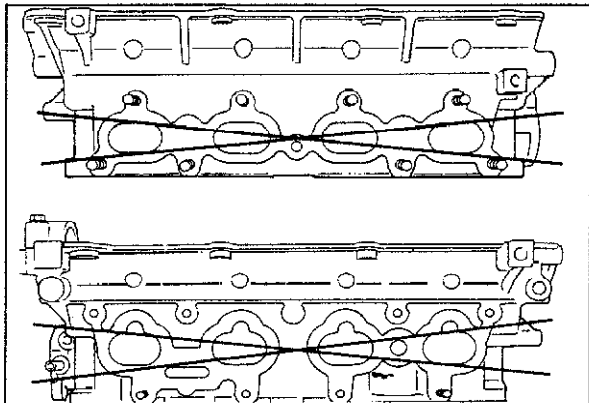

83U01A-061

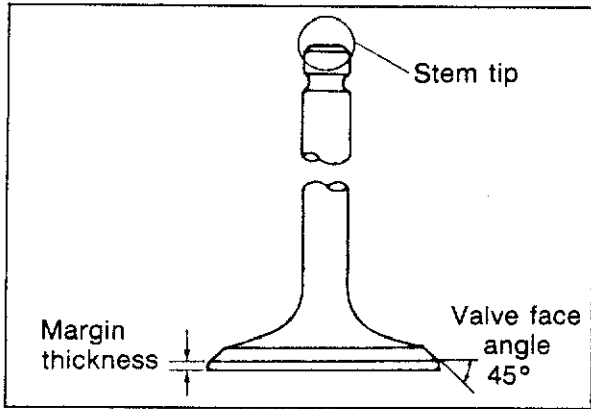

83U01B-48

## Valve and Valve Guide

1. Inspect each valve for the following, replace or resurface as necessary.
  - (1) Damaged or bent stem
  - (2) Roughness or damage to the face
  - (3) Damage or uneven wear of the stem tip
2. Check the valve head margin thickness, replace if necessary

### Margin thickness

**IN : 0.5 mm (0.020 in) min.**

**EX: 0.5 mm (0.020 in) min.**

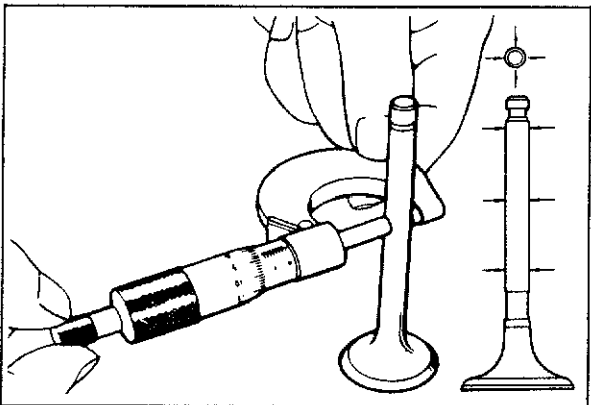

83U01B-049

3. Measure the valve length.

### Length

**IN : 105.29 mm (4.1452 in)**

**EX: 105.39 mm (4.1492 in)**

4. Measure the valve stem diameter.

### Diameter

**IN : 5.970—5.985 mm (0.2350—0.2356 in)**

**EX: 5.965—5.980 mm (0.2348—0.2354 in)**

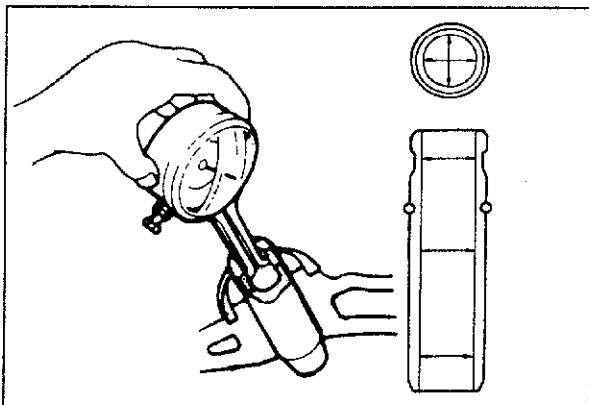

83U01B-050

5. Measure the valve guide inner diameter.

### Inner diameter

**IN : 6.01—6.03 mm (0.2366—0.2374 in)**

**EX: 6.01—6.03 mm (0.2366—0.2374 in)**

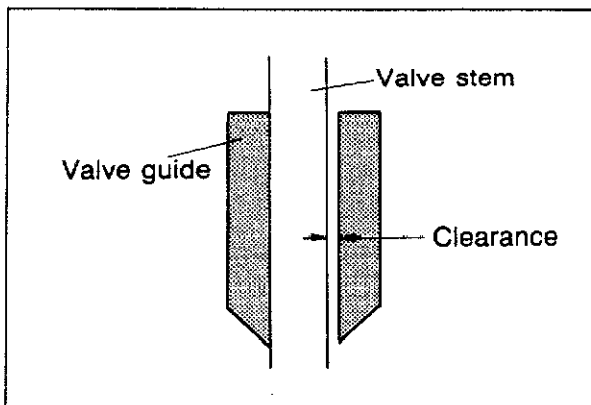

83U01A-064

6. Measure the valve stem to guide clearance.

#### (1) Method No. 1

Subtract the valve stem measurement from the corresponding valve guide inner diameter measurement.

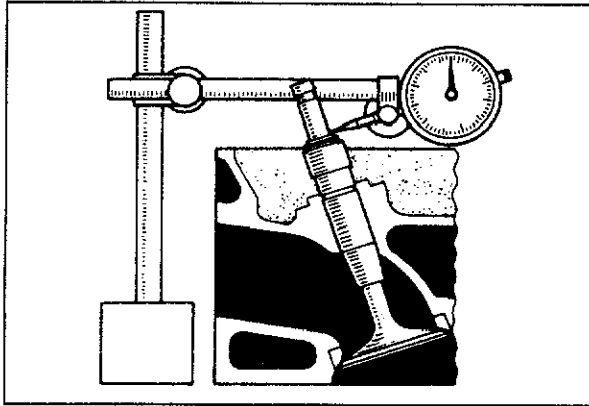

83U01B-051

(2) Method No. 2

Measure the valve stem play at a point close to the valve guide with the valve lifted off the valve seat.

**Clearance**

**IN : 0.025—0.060 mm (0.0010—0.0024 in)**

**EX : 0.030—0.065 mm (0.0012—0.0026 in)**

**Maximum: 0.20 mm (0.0079 in)**

7. If the clearance exceeds the maximum, replace the valve and/or valve guide.

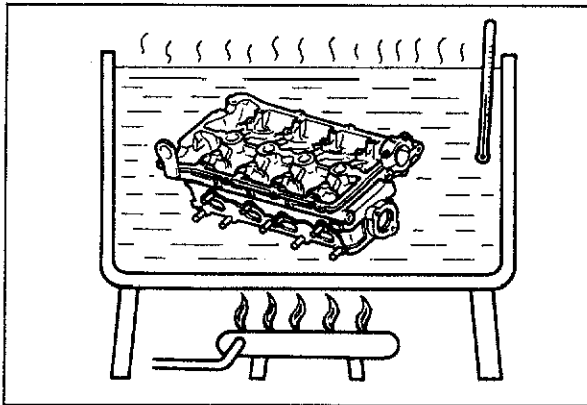

69G01B-093

**Replacement of valve guide**

**Removal**

1. Gradually heat the cylinder head in water to approx. **90°C (190°F)**.

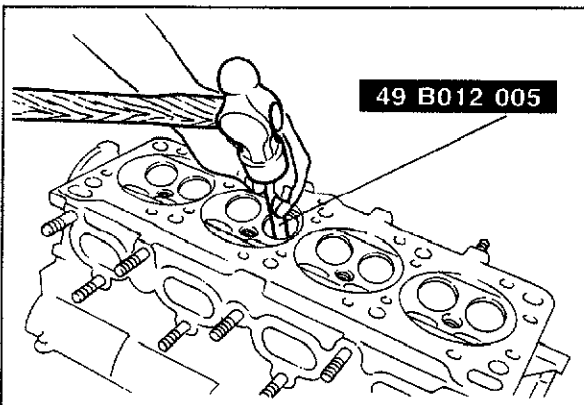

83U01B-052

2. Remove the valve guide from the side opposite the combustion chamber with the **SST**.
3. Remove the valve guide clip.

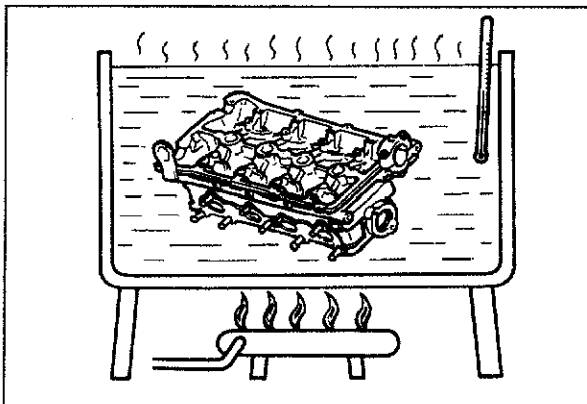

83U01A-113

**Installation**

1. Fit the clip onto the valve guide.
2. Gradually heat the cylinder head in water to approx. **90°C (190°F)**.
3. Tap the valve guide in from the side opposite the combustion chamber until the clip contacts the cylinder head with the **SST**.

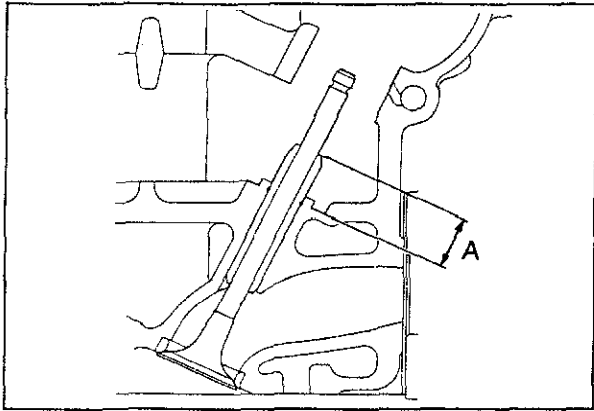

83U01B-053

4. Check that the protrusion height (dimension A in the figure) is within specification.

**Height:**

**16.8—17.4 mm (0.661—0.685 in)**

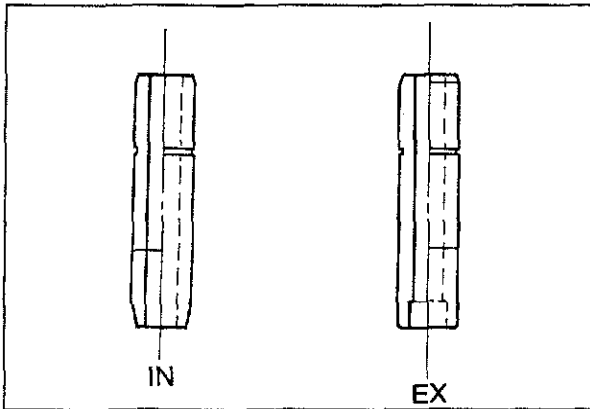

69G01B-098

**Note**

**Although the shapes of the intake and exhaust valve guides are different, use the exhaust valve guide on both sides as a replacement.**

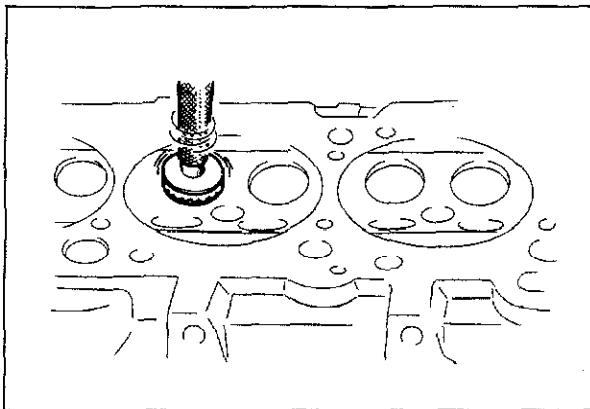

83U01B-066

**Valve Seat**

1. Inspect the contact surface of the valve seat and valve face.
  - (1) Roughness
  - (2) Damage
2. If necessary, resurface the valve seat using a **45°** valve seat cutter and/or resurface the valve face.

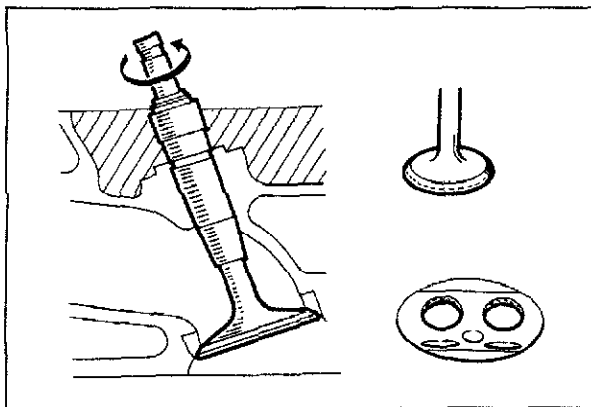

83U01B-114

3. Apply a thin coat of prussian blue to the valve face.
4. Check the valve seating by pressing the valve against the seat.
  - (1) If blue does not appear 360° around the valve face, replace the valve.
  - (2) If blue does not appear 360° around the valve seat, resurface the seat.

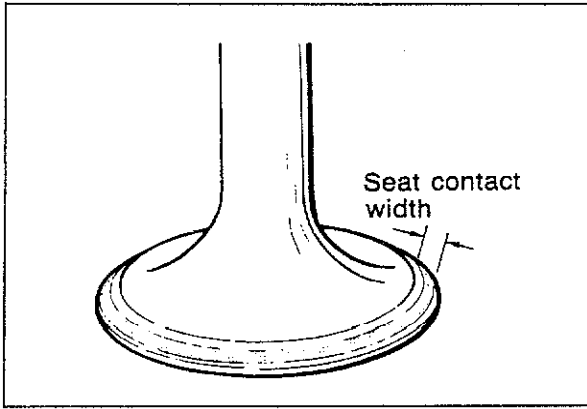

83U01B-054

5. Check the seat contact width and valve seating position on the valve face.

### Width:

**0.8—1.4 mm (0.031—0.055 in)**

6. Check that the valve seating position is at the center of the valve face.

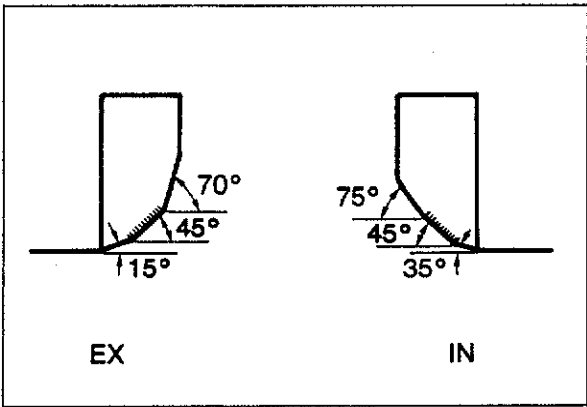

83U01A-068

- (1) If the seating position is too high, correct the valve seat using a **75°** cutter, and a **45°** cutter.
- (2) If the seating position is too low, correct the valve seat using a **35° (IN)** or **15° (EX)**, and a **45°** cutter.

7. Seat the valve to the valve seat using a lapping compound.

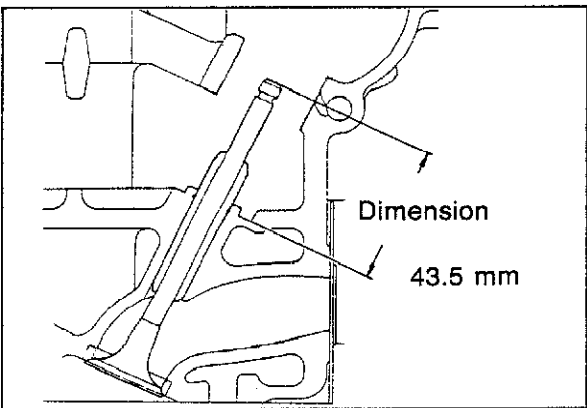

83U01B-055

8. Check the sinking of the valve seat. Measure protruding length (dimension "L") of the valve stem.

### Dimension "L": 43.5 mm (1.713 in)

- (1) If "L" is as below, it can be used as it is.

**43.5—44.0 mm (1.713—1.732 in)**

- (2) If "L" is as below, insert a spacer between the spring seat and cylinder head so that "L" will be as specified.

**44.0—45.0 mm (1.732—1.772 in)**

- (3) If "L" is more than as below, replace the cylinder head.

**45.0 mm (1.772 in) or more**

### Valve Spring

1. Inspect each valve spring for cracks or damage.
2. Check the free length and angle, replace if necessary.

### Free length

**Standard: 47.2 mm (1.858 in)**

**Minimum: 45.8 mm (1.803 in)**

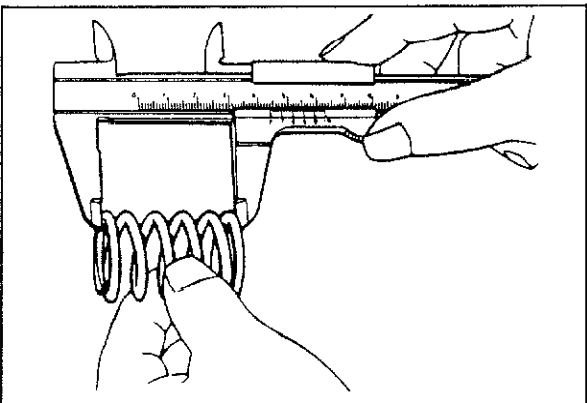

83U01B-056

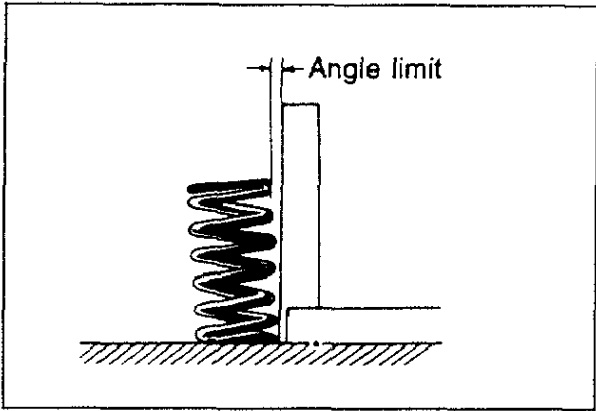

83U01B-057

**Angle: 1.6 mm (0.063 in) max.**

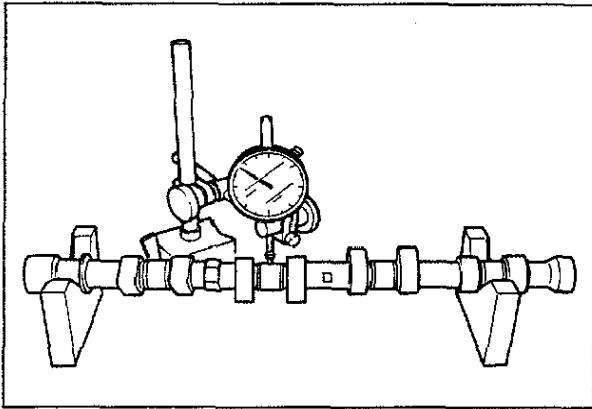

83U01A-074

**Camshaft**

1. Set the front and rear journals on V-blocks. Check the camshaft runout, replace if necessary.

**Runout: 0.03 mm (0.0012 in) max.**

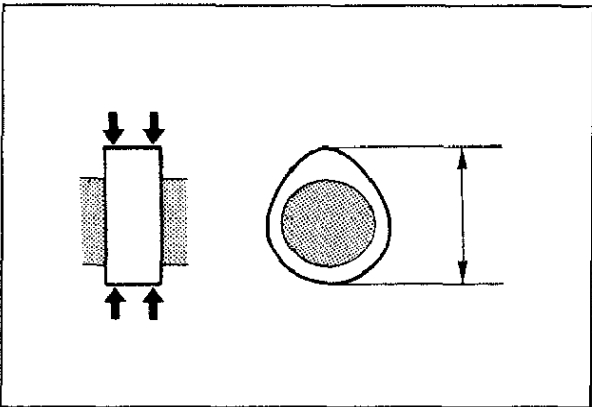

83U01B-058

2. Check the cam for wear or damage, replace if necessary.
3. Check the cam lobe height at the two places as shown.

**Height**

**IN : 40.888 mm (1.6098 in)**

**EX: 40.688 mm (1.6019 in)**

**Minimum**

**IN : 40.889 mm (1.6098 in)**

**EX: 40.689 mm (1.6019 in)**

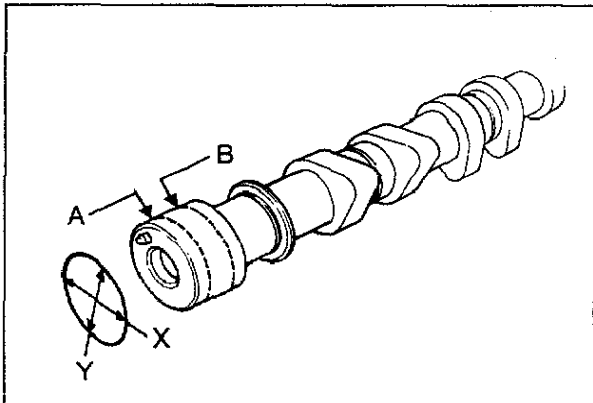

83U01B-059

4. Measure wear of the journals in X and Y directions at the two places shown.

**Diameter**

**No.1—No.5:**

**25.940—25.965 mm (1.0213—1.0222 in)**

**No.6:**

**33.961—34.000 mm (1.3370—1.3386 in)**

**Out-of-round: 0.05 mm (0.002 in) max.**

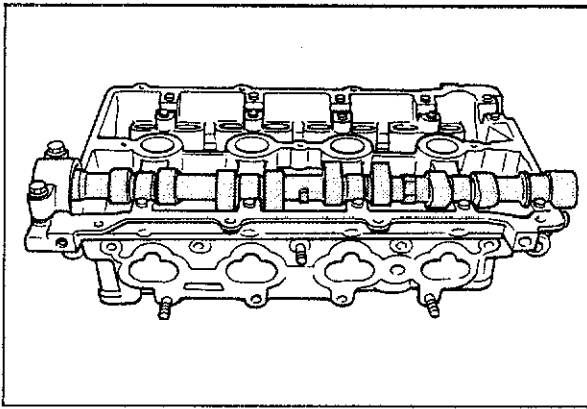

83U01B-060

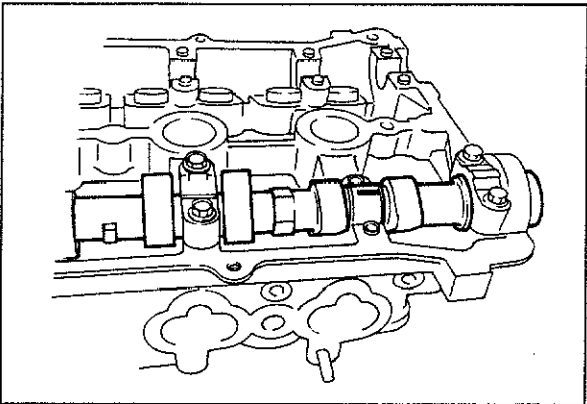

83U01B-061

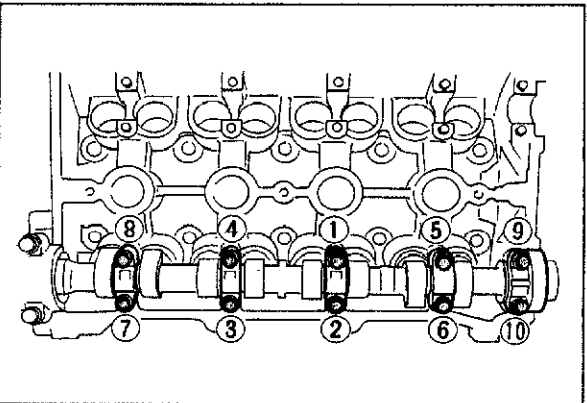

83U01B-062

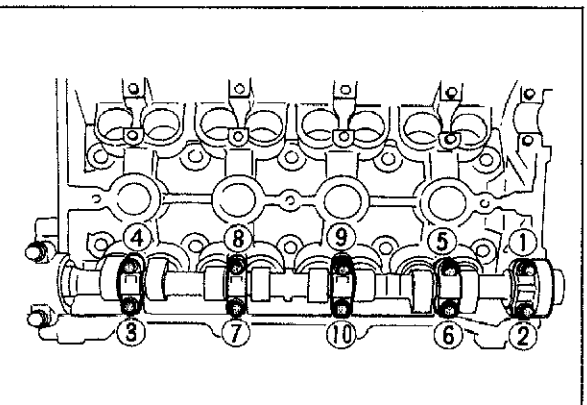

83U01B-063

5. Measure the oil clearances of the camshaft and cylinder head.
  - (1) Remove any oil, or dirt from the journals and bearing surface.
  - (2) Set the camshaft on the cylinder head.

**Note**

**Do not install the HLA, when measuring the oil clearance.**

- (3) Position the plastic-gauge on top of the journal in the journal axial direction.

- (4) Install the camshaft caps according to the cap number and arrow, tighten them in the order shown in the figure.

**Tightening torque: 11—14 N·m  
(1.15—1.45 m·kg, 100—126 in·lb)**

- (5) Loosen the camshaft cap bolts in the order shown in the figure.

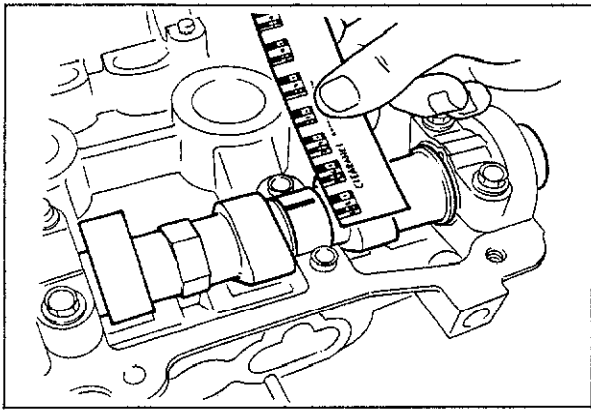

83U01B-064

(6) Measure the oil clearance.

**Oil clearance**

**No. 1—No. 5:**

**0.035—0.081 mm (0.0014—0.0032 in)**

**Maximum: 0.15 mm (0.0059 in)**

(7) If the oil clearance exceeds the maximum, replace the camshaft or the cylinder head.

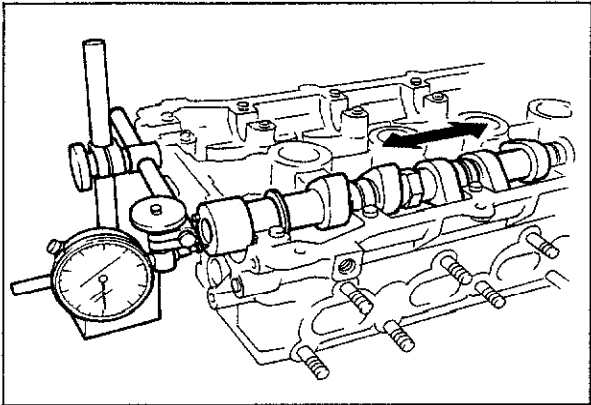

83U01B-065

6. Measure the camshaft end play. If it exceeds the maximum, replace the camshaft or the cylinder head.

**End play:**

**0.07—0.19 mm (0.0028—0.0075 in)**

**Maximum: 0.20 mm (0.008 in)**

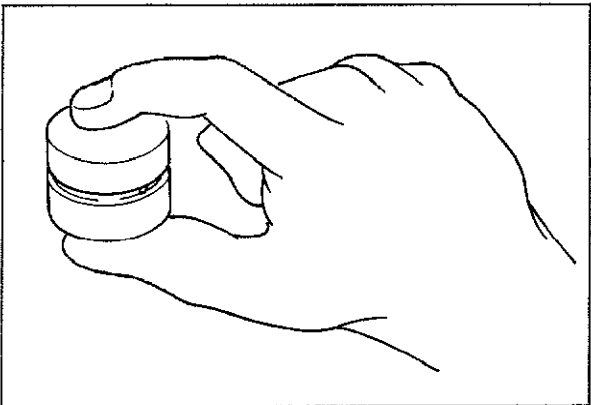

63G01C-061

**HLA**

1. Check the HLA for wear or damage.
2. Hold the HLA between your fingers and press it. If the HLA moves, replace it.

**Note**

**Do not disassemble the HLA**

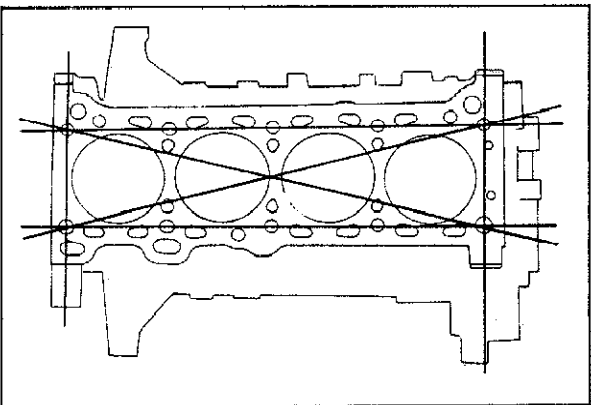

69G01A-117

**Cylinder Block**

1. Check the cylinder block, repair or replace if necessary.

- (1) Leakage damage
- (2) Cracks
- (3) Scoring of wall

2. Measure the distortion of the top surface of the cylinder block in the six directions shown in figure.

**Distortion: 0.15 mm (0.006 in) max.**



# 1B INSPECTION AND REPAIR

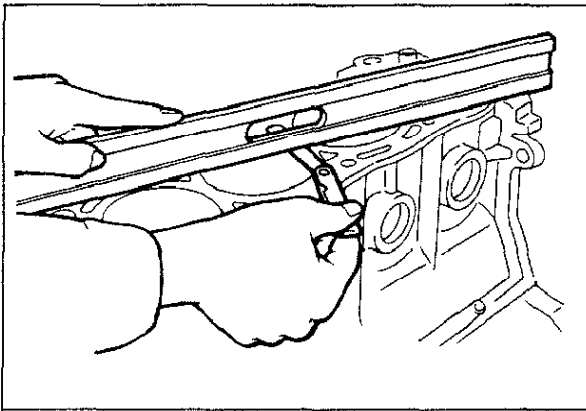

69G01A-118

3. If the distortion exceeds the maximum, repair by grinding, or replace the cylinder block.

**Grinding: 0.20 mm (0.008 in) max.**

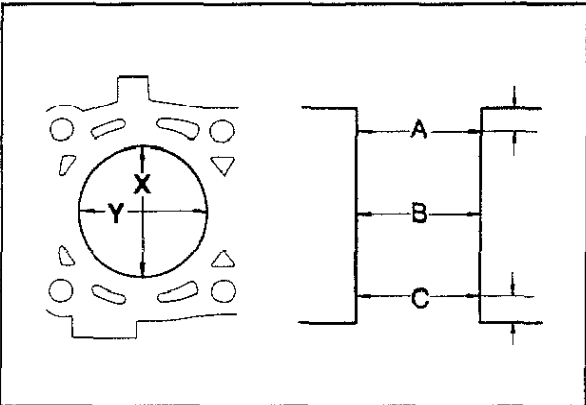

83U01B-066

4. Measure the cylinder bore in directions X and Y at three levels in each cylinder as shown.

**Cylinder bore** mm (in)

Size	Bore
Standard	78.000—78.019 (3.0709—3.0717)
0.25 (0.010) oversize	78.250—78.269 (3.0807—3.0815)
0.50 (0.020) oversize	78.500—78.519 (3.0905—3.0913)

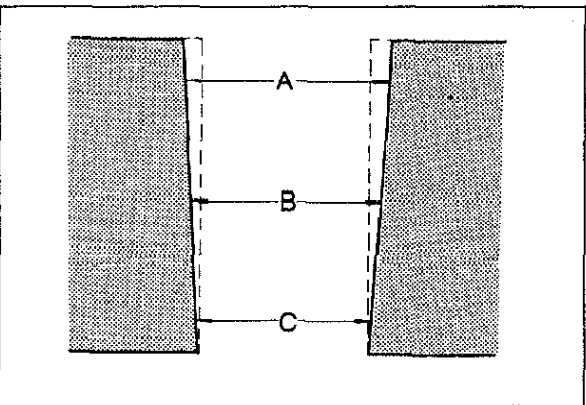

83U01A-083

- (1) If the difference between the measurement A and C exceeds the maximum taper, rebore the cylinder to oversize.

**Taper: 0.019 mm (0.0007 in) max.**

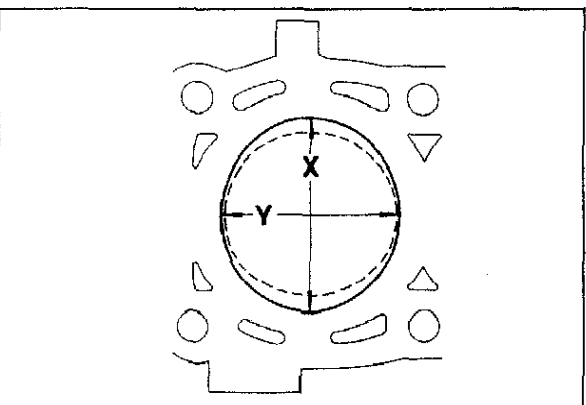

83U01A-084

- (2) If the difference between the measurement X and Y exceeds the maximum out-of-round, rebore the cylinder to oversize.

**Out-of-round: 0.019 mm (0.0007 in) max.**

**Caution**

The boring size should be the same for all cylinders.

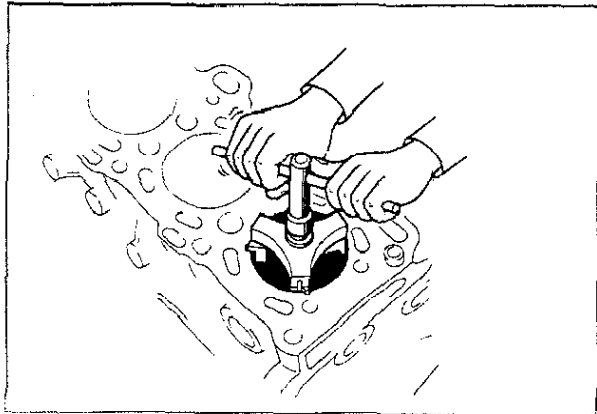

69G01A-122

- If the upper part of the cylinder wall shows uneven wear, remove the ridge using a ridge reamer.

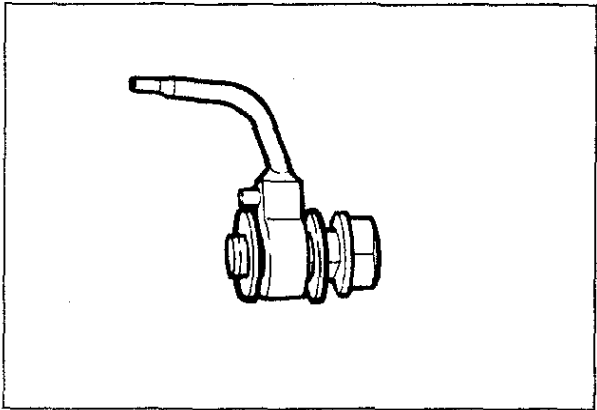

63G01C-063

### Oil Jet

- Check the oil jet for clogging.

#### Note

**Make sure that the oil passages are not clogged.**

- Check the check ball move smoothly.

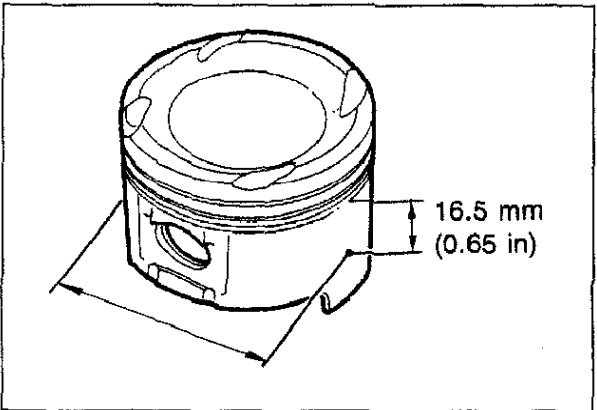

83U01A-085

### Piston

- Inspect the outer circumferences of all pistons for seizure or scoring, replace if necessary.
- Measure the outer diameter of each piston at a right angle (90°) to the piston pin, **16.5 mm (0.650 in) below** the oil ring land lower edge.

### Piston diameter

mm (in)

Size	Diameter
Standard	77.954—77.974 (3.0690—3.0698)
0.25 (0.010) oversize	78.204—78.224 (3.0789—3.0797)
0.50 (0.020) oversize	78.454—78.474 (3.0887—3.0895)

- Check the piston to cylinder clearance.

#### Clearance:

**0.026—0.065 mm (0.0010—0.0026 in)**

**Maximum: 0.15 mm (0.0059 in)**

- If the clearance exceeds the maximum, replace the piston or rebore the cylinder to oversize.

#### Note

**If the piston is replaced, replace the piston rings also.**

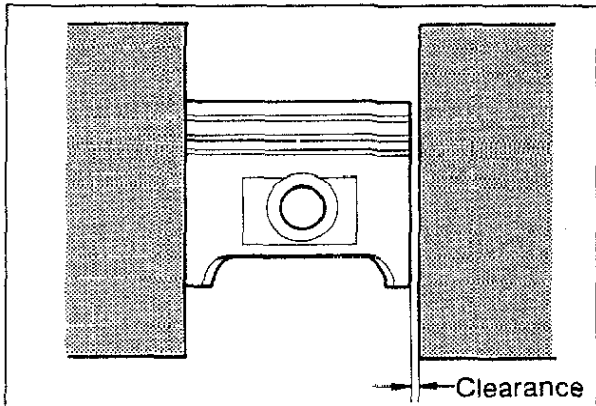

83U01A-086

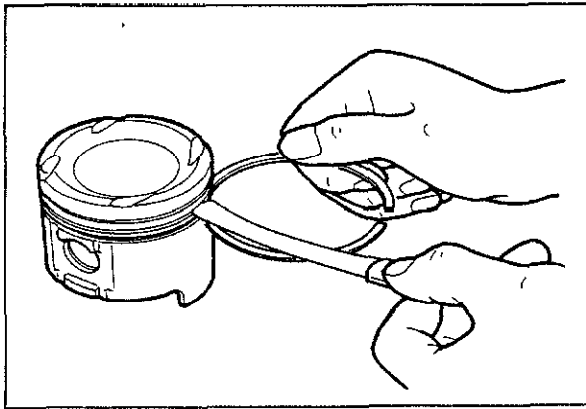

83U01A-087

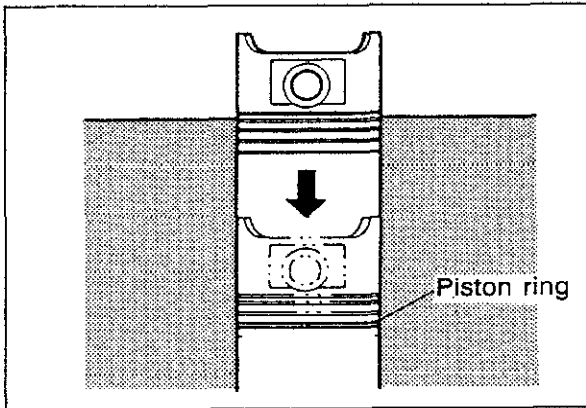

83U01A-088

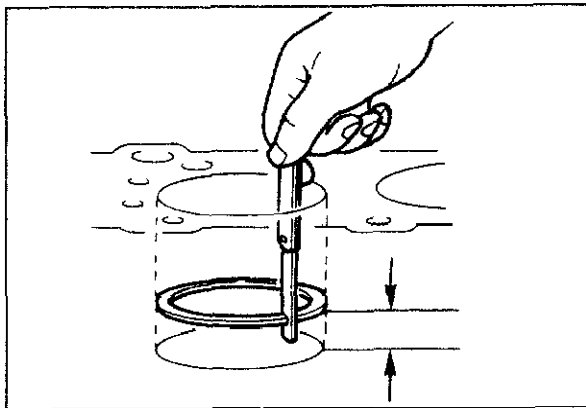

83U01A-089

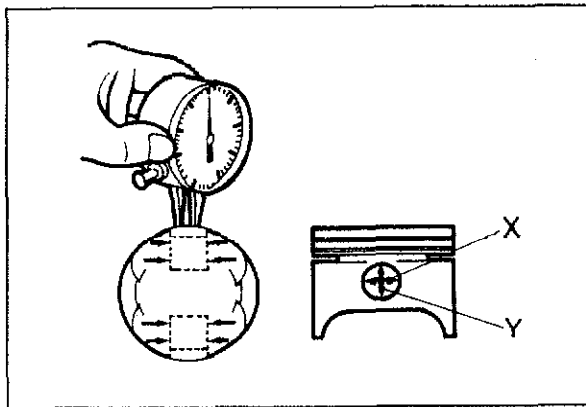

83U01A-090

## Piston and Piston Ring

1. Measure the piston ring to ring land clearance around the entire circumference using a new piston ring.

### Clearance (Top and Second):

**0.030—0.065 mm (0.0012—0.0026 in)**

**Maximum: 0.15 mm (0.006 in)**

2. If the clearance exceeds the maximum, replace the piston.

3. Inspect the piston rings for damage, abnormal wear, or breakage, replace if necessary.

4. Insert the piston ring into the cylinder by hand and push it to the bottom of the ring travel in using the piston.

5. Measure each piston ring end gap using a feeler gauge, replace if necessary.

### End gap

**Top : 0.20—0.40 mm (0.008—0.016 in)**

**Second: 0.15—0.30 mm (0.006—0.012 in)**

**Oil rail : 0.20—0.70 mm (0.008—0.028 in)**

**Maximum: 1.0 mm (0.039 in)**

## Piston and Piston Pin

1. Measure the piston pin hole diameter in X and Y directions at four places.

### Diameter:

**19.988—20.000 mm (0.7869—0.7874 in)**

2. Measure the piston pin diameter in the same manner.

### Diameter:

**19.987—19.993 mm (0.7869—0.7871 in)**

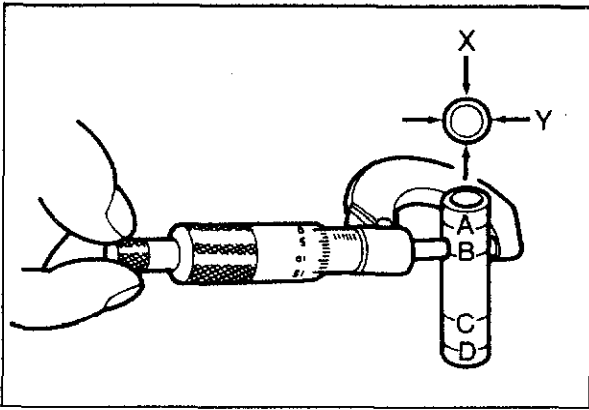

83U01B-068

3. Check the piston pin to piston clearance.

**Clearance:**

**-0.005—0.013 mm (-0.0002—0.0005 in)**

4. If the clearance exceeds the maximum, replace the piston and/or piston pin.

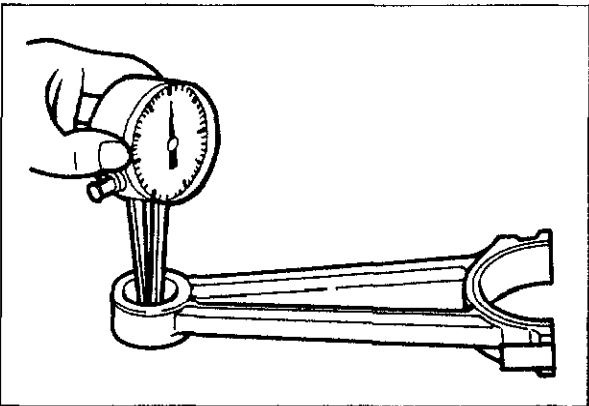

83U01B-069

**Connecting Rod**

1. Measure the connecting rod small end bore.

**Diameter:**

**20.003—20.014 mm (0.7875—0.7880 in)**

2. Check the clearance between the small end bore and piston pin.

**Clearance:**

**0.010—0.027 mm (0.0004—0.0012 in)**

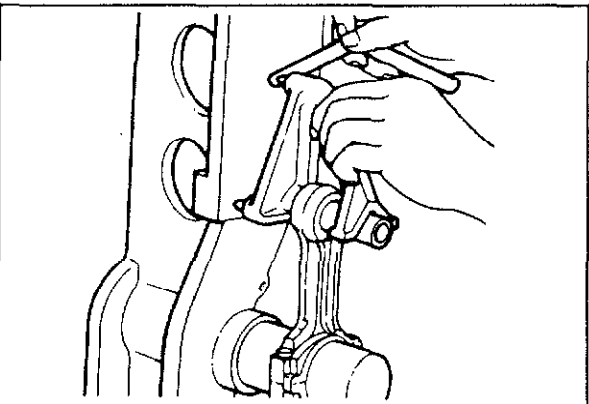

69G01B-115

3. Check each connecting rod for bending or twisting, if necessary replace or repair.

**Bend: 0.04 mm (0.0016 in) max.**

**Twist: 0.04 mm (0.0016 in) max.**

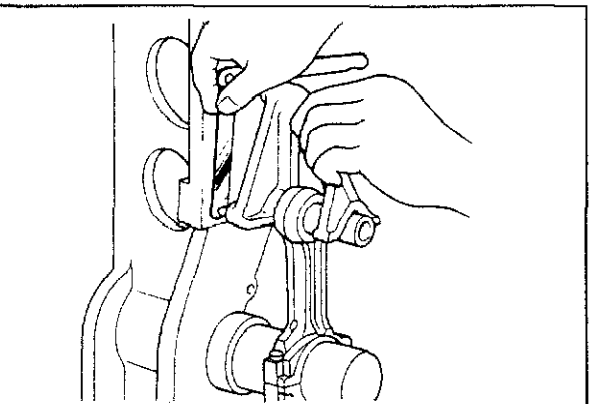

69G01B-116

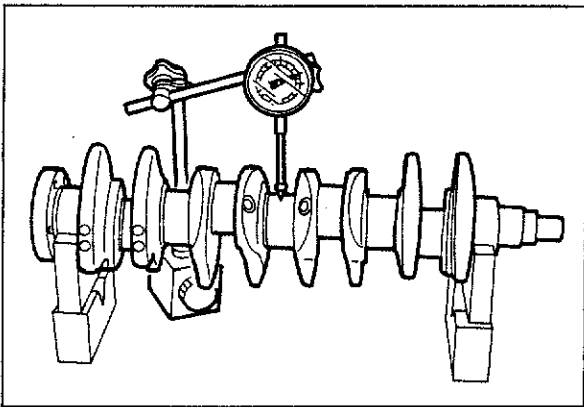

83U01A-093

## Crankshaft

1. Check the journals and pins for damage, scoring, or oil hole clogging.
2. Set the crankshaft on V-blocks.
3. Check the crankshaft runout at the center journal, replace if necessary.

**Runout: 0.04 mm (0.0016 in) max.**

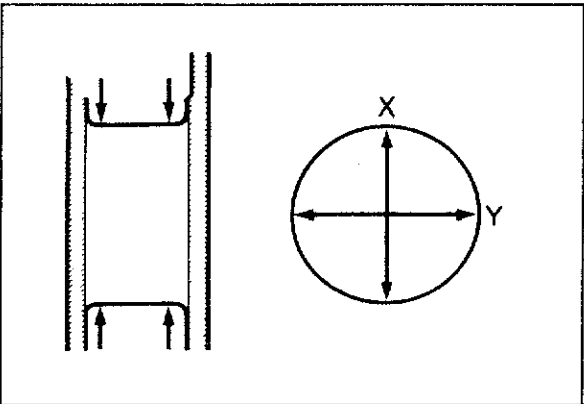

83U01A-094

4. Measure each journal diameter in X and Y directions at two places.

### Main journal

**Diameter:**

**49.938—49.956 mm (1.9661—1.9668 in)**

**Minimum: 49.89 mm (1.964 in)**

**Out-of-round: 0.05 mm (0.0020 in) max.**

### Crankpin journal

**Diameter:**

**44.940—44.956 mm (1.7693—1.7699 in)**

**Minimum: 44.89 mm (1.7673 in)**

**Out-of-round: 0.05 mm (0.0020 in) max.**

5. If the diameter is below the minimum, grind the journals to match undersize bearings.

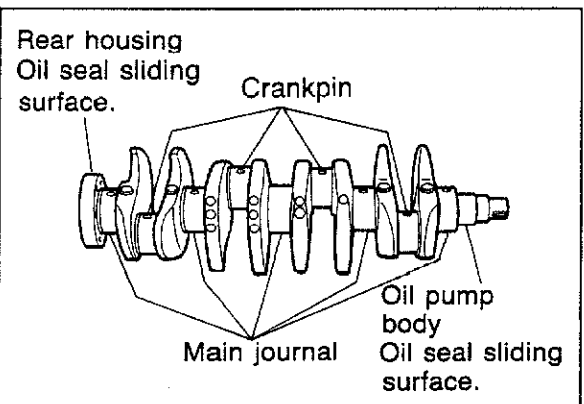

83U01A-095

### Undersize bearing:

**0.25 mm (0.010 in), 0.50 mm (0.020 in)**

### Main journal diameter undersize mm (in)

Bearing size	Journal diameter
0.25 undersize	49.688—49.706 (1.9562—1.9569)
0.50 undersize	49.438—49.456 (1.9464—1.9471)

### Crankpin journal diameter undersize mm (in)

Bearing size	Journal diameter
0.25 undersize	44.690—44.706 (1.7594—1.7601)
0.50 undersize	44.440—44.456 (1.7496—1.7502)

### Caution

**Do not grind the fillet roll.**

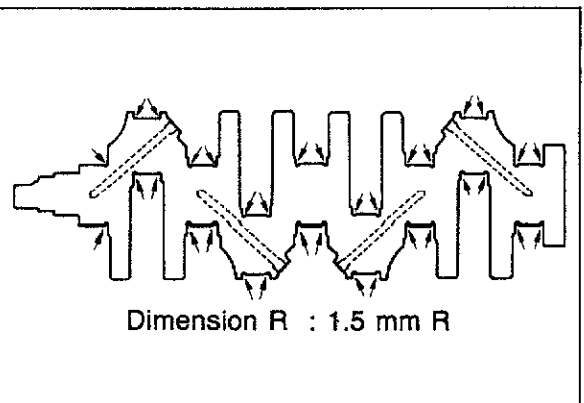

83U01A-096

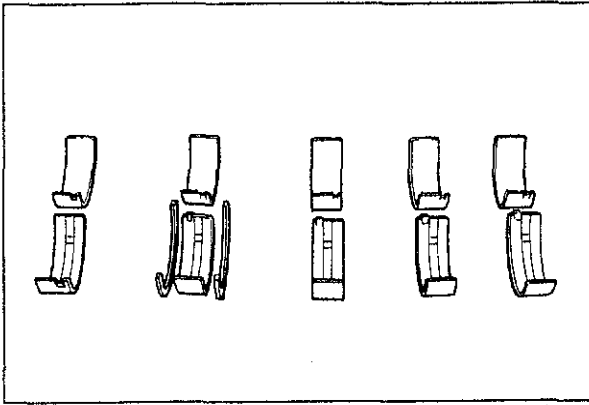

83U01A-097

## Main Bearing and Connecting Rod Bearing

Check the main bearings and the connecting rod bearings for peeling, scoring, or other damage.

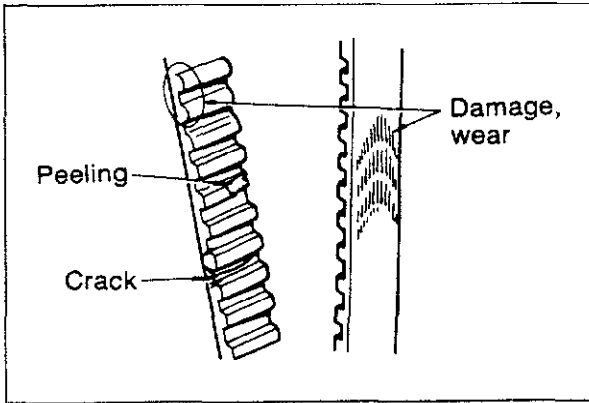

69G01B-121

## Timing Belt

1. Replace the timing belt if there is any oil or grease on it.
2. Check the timing belt for damage, wear, peeling, cracks, or hardening, replace if necessary.

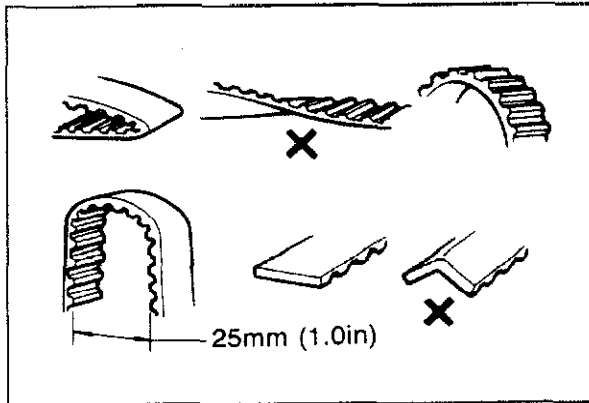

69G01B-122

## Caution

- a) Never forcefully twist the timing belt. Do not turn it inside out or bend it.
- b) Be careful not to allow oil or grease on the belt.

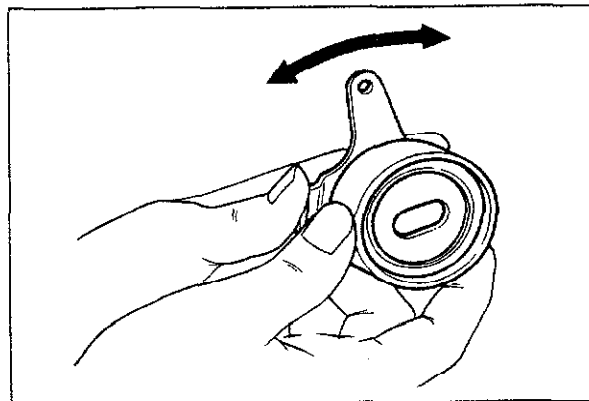

83U01A-098

## Timing Belt Tensioner and Idler Pulley

Check the timing belt tensioner and idler pulley for smooth rotation or abnormal noise, replace if necessary.

## Caution

Do not clean the tensioner with cleaning fluids. If necessary, use a soft rag to wipe it clean, and avoid scratching it.

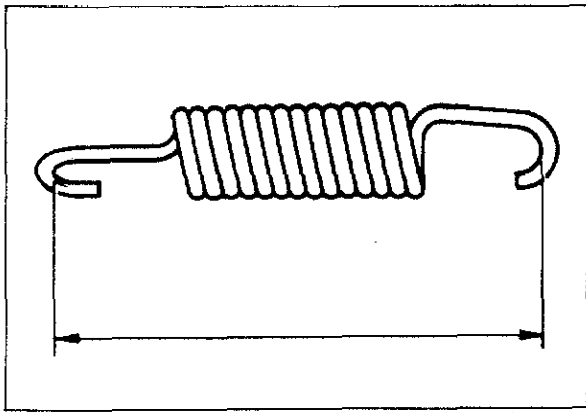

83U01B-070

### Timing Belt Tensioner Spring

Check the free length of the tensioner spring, replace if necessary.

**Free length:**  
58.8 mm (2.315 in)

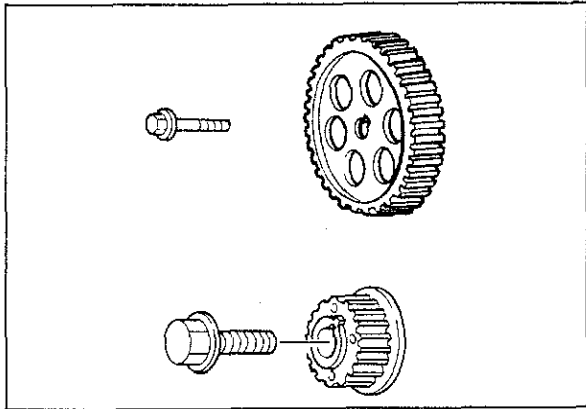

83U01B-071

### Timing Belt Pulley and Camshaft Pulley

Inspect the pulley teeth for wear, deformation, or other damage, replace the pulley if necessary.

#### Caution

**Do not clean the pulley with cleaning fluids.  
If necessary, use a rag to wipe it clean.**

### Timing Belt Cover (lower, middle and upper)

Inspect the timing belt covers for deformation or cracks, replace if necessary.

## ASSEMBLY

### Assembly Note

1. Be sure all parts are clean before reinstallation.
2. Apply new engine oil to all sliding and rotating parts.
3. Do not reuse gaskets or oil seals.
4. During assembly, inspect all critical clearances, end plays and oil clearances.
5. Tighten bolts to the specified torques.
6. Replace bearings if they are peeling, burned, or otherwise damaged.

4BG01A-136

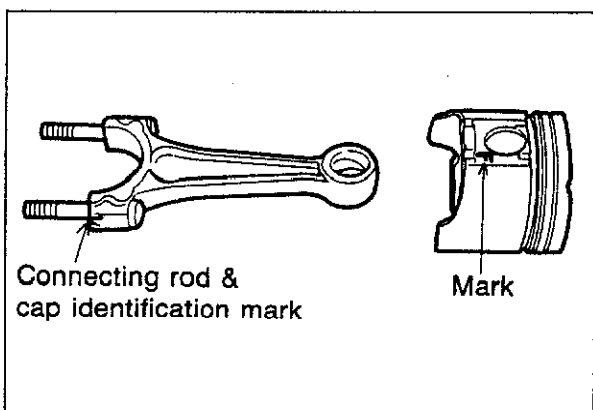

63G01C-112

### Connecting Rod

1. Align the identification mark to the cap of lage end of connecting rod and "F" mark on the piston as shown in the figure.
2. Apply a coat of engine oil to the circumference of each piston pin and to the small end of each connecting rod.

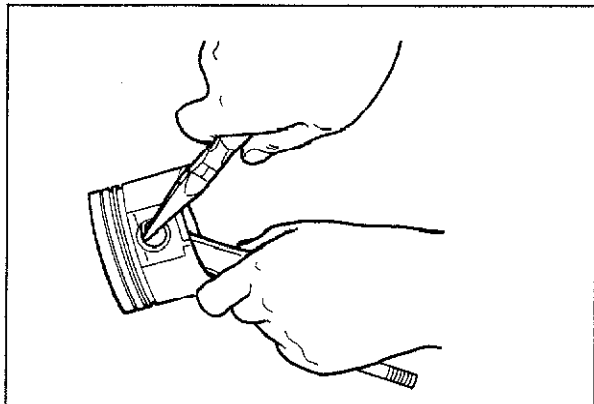

63G01C-073

3. Set a clip into the clip groove in one side of the piston.
4. Assemble the piston and connecting rod.

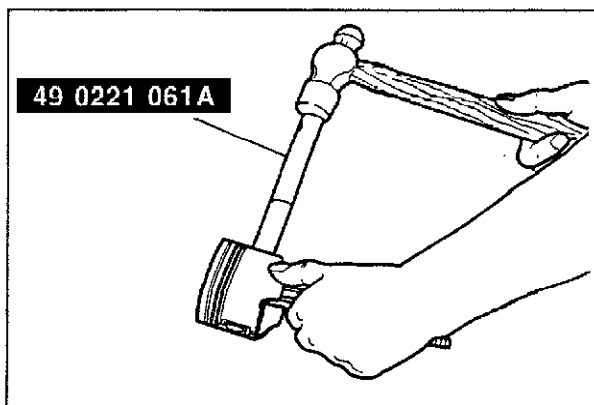

83U01X-126

5. Using the **SST**, insert the piston pin from the opposite side of the piston.
6. Tap the piston pin into touch the clip. Install the other clip into the groove in the piston.



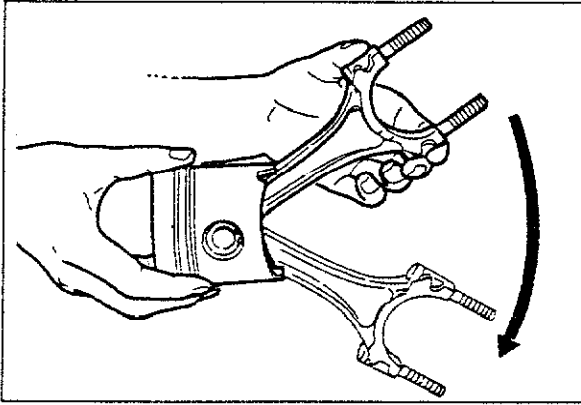

63G01C-075

7. If the piston pin cannot be tapped in easily, replace the piston pin or the connecting rod.
8. Check the oscillation torque of the connecting rod as shown in the figure. If the large end does not drop by its own weight, replace the piston and piston pin.

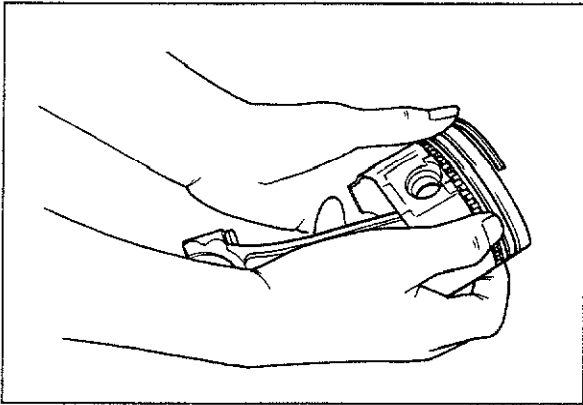

4BG01A-143

## Piston Ring

1. Install the three-piece oil rings on the pistons.
  - (1) Apply engine oil to the oil ring spacer and rails.
  - (2) Install the oil ring spacer.
  - (3) Install the upper rail and lower rail.

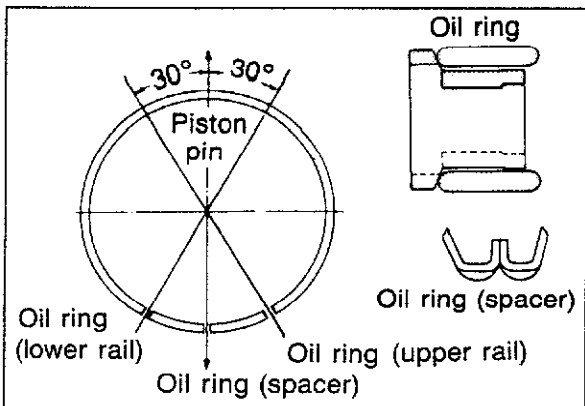

4BG01A-144

## Caution

- a) After installation of the upper and lower side rails, make certain they turn smoothly in both directions.
- b) Do not align the end gaps, stagger them.

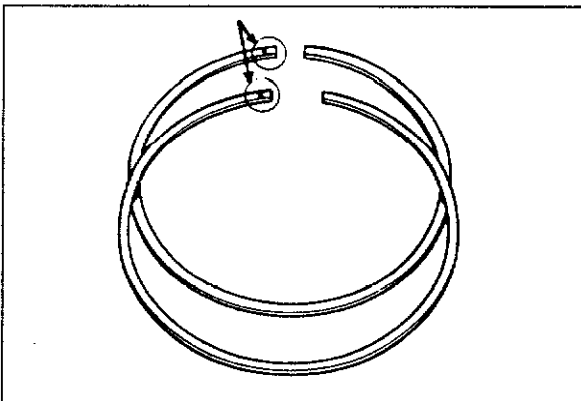

4BG01A-145

2. Install the second and top ring.
  - (1) Apply a liberal coat of engine oil to the piston rings.
  - (2) Install the second ring to the piston first, then the top one, using a piston ring insertion tool, (commercially available).

## Caution

The rings must be installed so the "R" marks face upward.

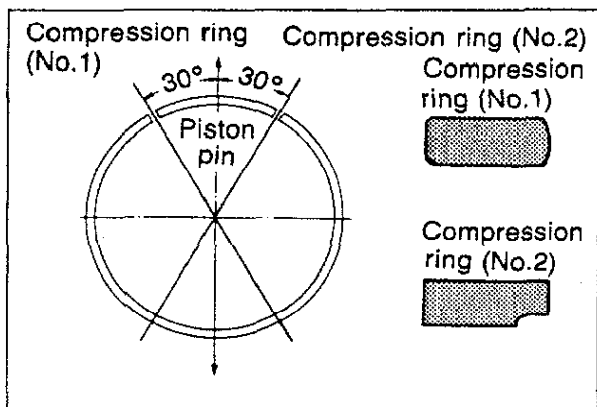

5BU01X-208

- (3) Position the opening of each ring as shown in the figure.

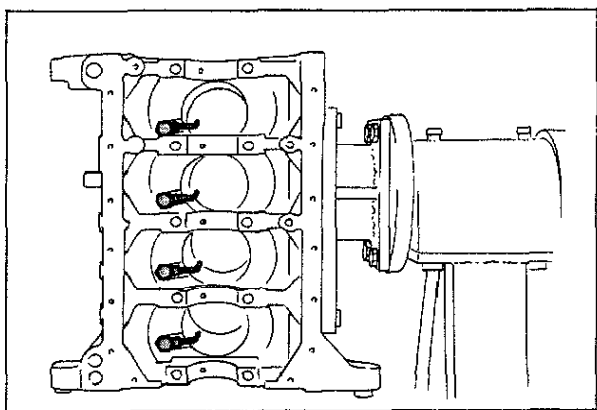

63G01C-076

### Oil Jet

Install the oil jet as shown in the figure.

**Tightening torque: 12—18 N·m  
(1.2—1.8 m·kg, 104—156 in·lb)**

### Note

**Before installation make sure that the oil passage is not clogged.**

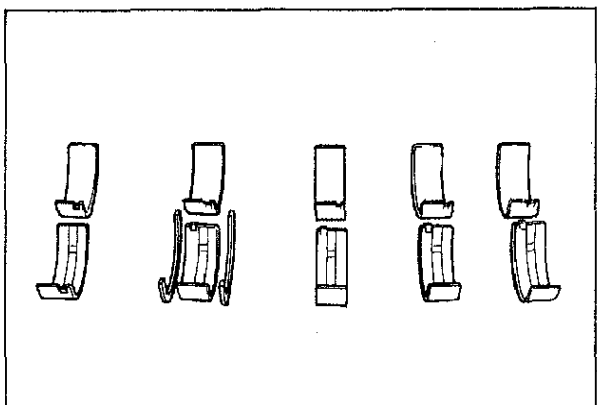

63U01X-095

### Crankshaft

1. Inspect the oil clearances of the crankshaft and main bearings.

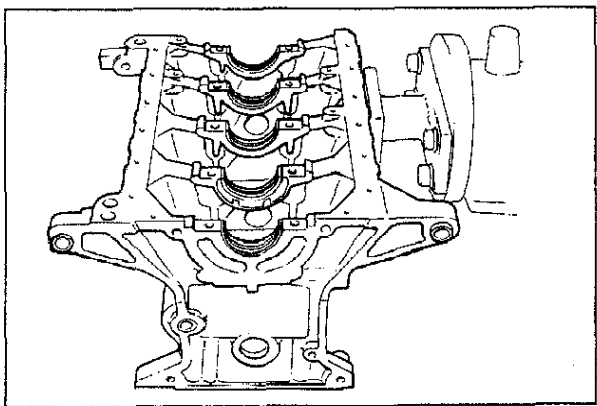

4BG01A-147

- (1) Remove any foreign material and oil from the journal and bearing.
- (2) Install the main bearings and the crankshaft.

### Caution

**The main bearing with the oil grooves must be install in the cylinder block.**

- (3) Position the plasti-gauge on top of each journal (in the journal axial direction), away from the oil hole.

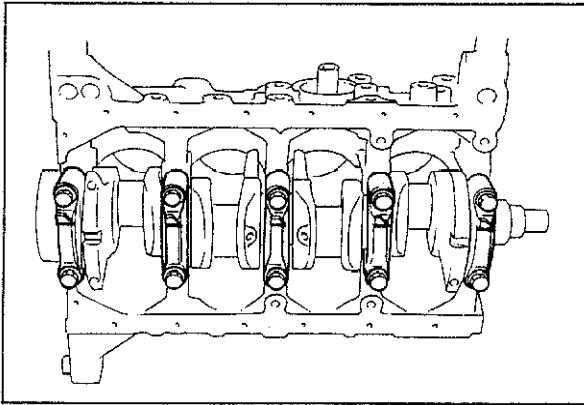

63U01X-096

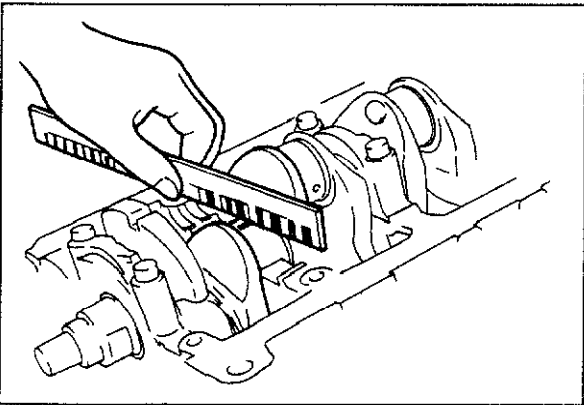

83U01B-072

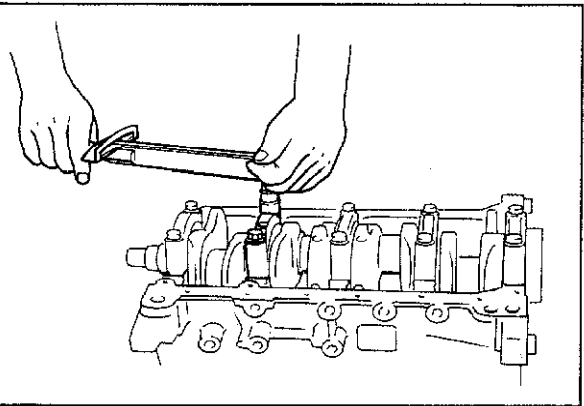

63G01C-078

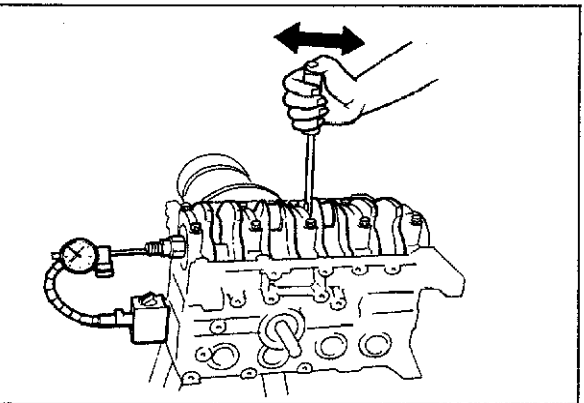

83U01B-073

- (4) Set the main bearing caps according to the cap number and  mark, and tighten them.

### Note

Do not rotate the crankshaft when measuring the oil clearances.

### Tightening torque:

**54—59 N·m (5.5—6.0 m·kg, 40—43 ft·lb)**

- (5) Remove the main bearing cap, and measure the plasti-gauge at each journal at the widest point for the smallest clearance, and at the narrowest point for the largest clearance.

### Oil clearance:

**0.024—0.042 mm (0.0010—0.0017 in)**

### Maximum:

**0.08 mm (0.0031 in)**

- (6) If the oil clearance exceeds the limit, grind the crankshaft and use undersize main bearings.

### Undersize main bearings:

**0.25 mm (0.010 in), 0.50 mm (0.020 in)**

2. Apply engine oil to the main bearings and main journals.
3. Install the thrust bearings to the cylinder block side.
4. Install the crankshaft, and install the main bearing caps according to the cap number and  mark.

5. Inspect crankshaft end play.

### End play:

**0.08—0.242 mm (0.0031—0.0111 in)**

### Maximum:

**0.30 mm (0.012 in)**

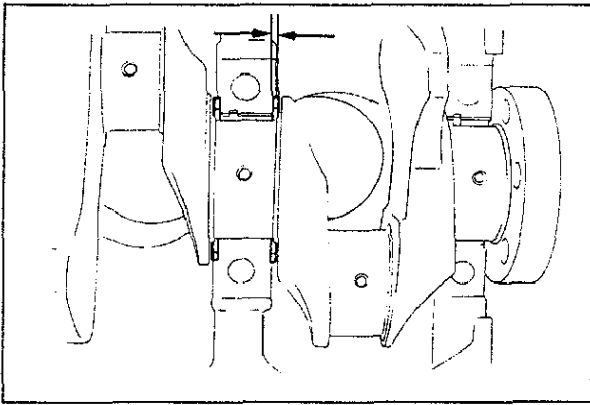

83U01B-074

If end play exceeds the limit, adjust the end play with thrust bearings.

**Standard thickness:**

2.50—2.55 mm (0.0984—0.1004 in)

**Undersize width:**

0.25 mm (0.010 in):

2.625—2.675 mm (0.1033—0.1053 in)

0.50 mm (0.020 in):

2.750—2.800 mm (0.1083—0.1102 in)

**Note**

Oil groove of the thrust bearing must face the crankshaft.

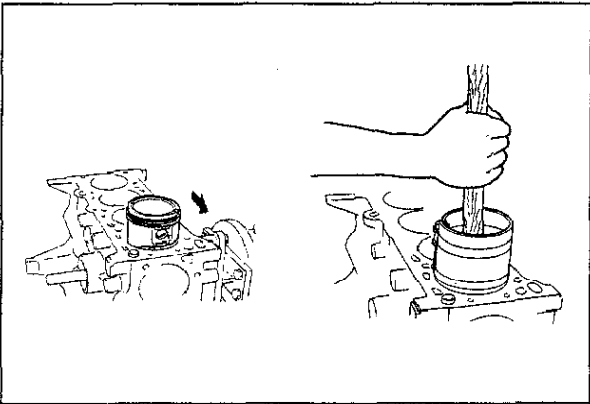

4BG01A-154

**Piston and Connecting Rod Assembly**

1. Apply engine oil to the cylinder walls, piston circumference, and rings.
2. Insert each piston and connecting rod into the cylinder block by using a piston insertion tool, (commercially available).

**Caution**

The pistons must be inserted so that the "F" marks face the front of the cylinder block.

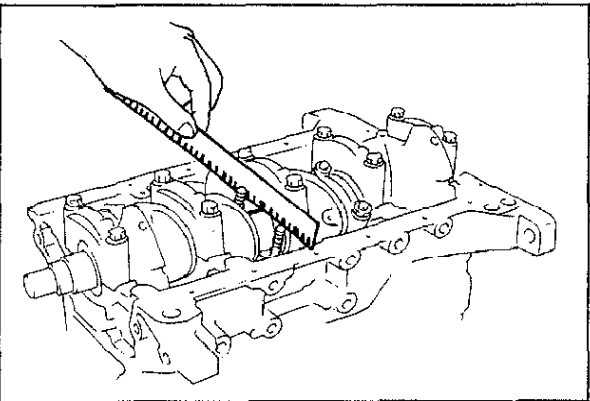

83U01B-075

**Connecting Rod Cap**

1. Inspect and adjust the connecting rod bearing and crankshaft pin journal oil clearance by the same procedure used for the crankshaft and main bearing oil clearance.

**Connecting rod cap tightening torque:**

65—69 N·m (6.6—7.0 m·kg, 48—51 ft·lb)

**Oil clearance:**

0.028—0.068 mm (0.0011—0.0027 in)

**Maximum:**

0.10 mm (0.0039 in)

**Undersize connecting rod bearing:**

0.25 mm (0.010 in), 0.50 mm (0.020 in)

**Caution**

Be sure to align the connecting rod caps and on the connecting rod when installing the connecting rod cap.

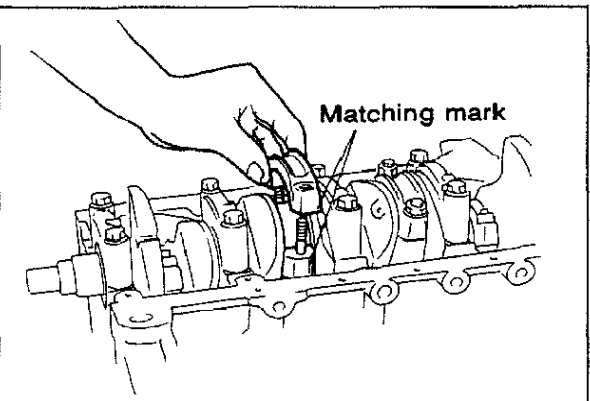

63G01C-081

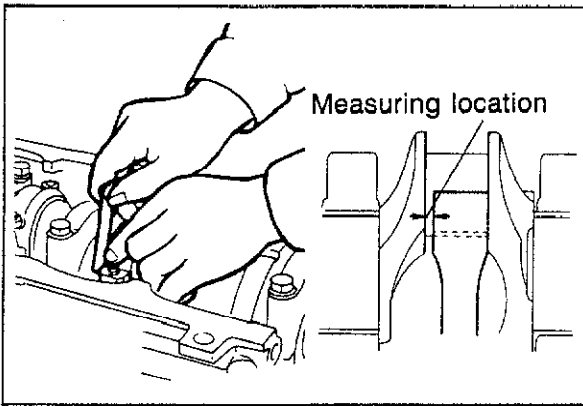

83U01B-115

2. Check the side clearance of the connecting rods.

**Clearance: 0.30 mm (0.0118 in) max.**

**Caution**

**The connecting rod side clearance must be measured before installation.**

3. Apply engine oil to the crankpin journal and connecting rod bearing.
4. Install the connecting rod cap to align the matching mark and tighten it.

**Tightening torque:**

**65—69 N·m (6.6—7.0 m·kg, 48—51 ft·lb)**

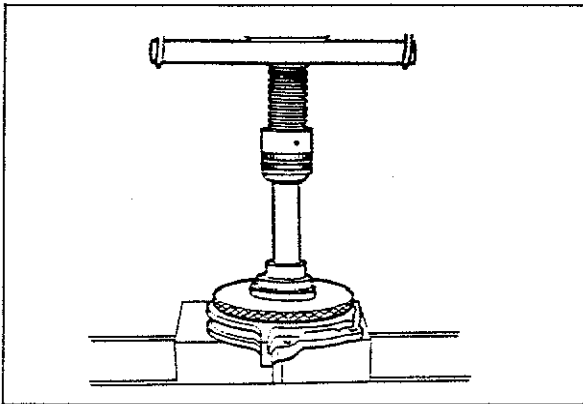

63U01X-102

**Rear Cover**

1. Apply engine oil to the rear cover, oil seal and oil seal lip.
2. Press the oil seal into the rear cover.

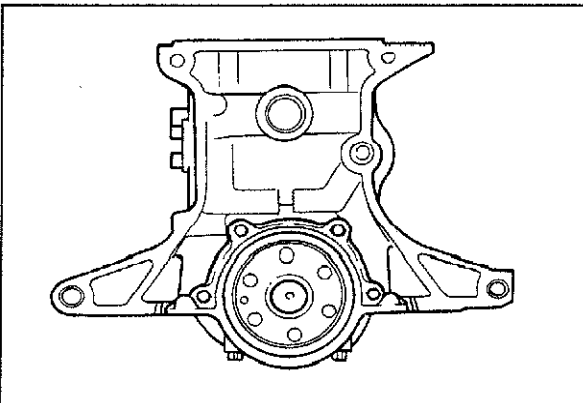

63U01X-103

3. Install the rear cover along with a new gasket.

**Tightening torque:**

**8—11 N·m (0.8—1.1 m·kg, 69—95 in·lb)**

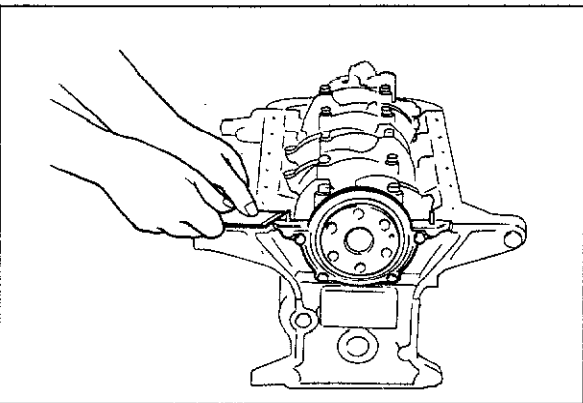

63G01C-083

4. Cut away the exposed part of the gasket that projects out from the rear cover assembly.

**Caution**

**Do not scratch the rear cover assembly.**

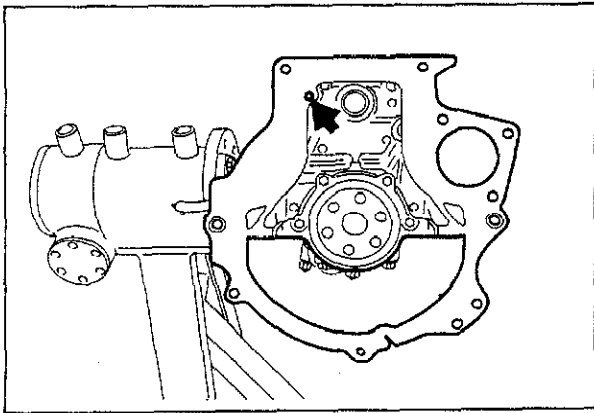

63U01X-104

### End Plate

Install the end plate.

#### Tightening torque:

8—11 N·m (0.8—1.1 m·kg, 69—95 in·lb)

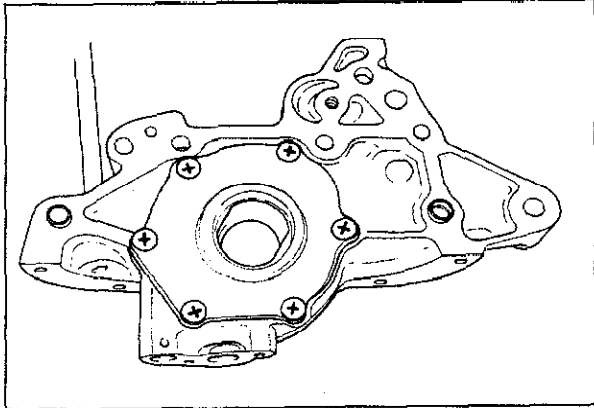

63U01X-105

### Oil Pump

1. Remove any dirt or grease from the contact surfaces of the cylinder block and oil pump with a rag.
2. Apply engine oil to the oil seal lip.
3. Install new gasket.

#### Caution

Do not allow any sealant in the oil hole.

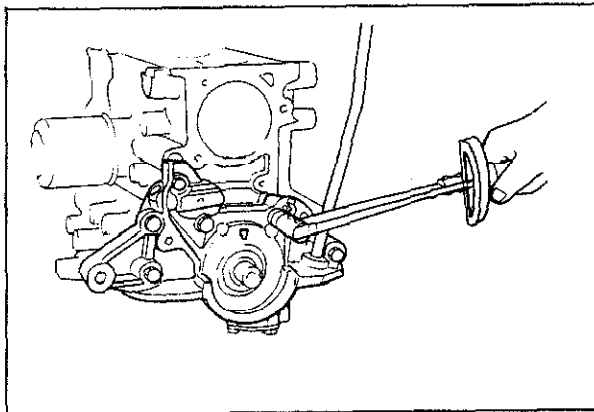

63U01X-106p

4. Install the oil pump.

#### Tightening torque:

19—26 N·m (1.9—2.6 m·kg, 14—19 ft·lb)

5. Remove any sealant which is squeezed out.

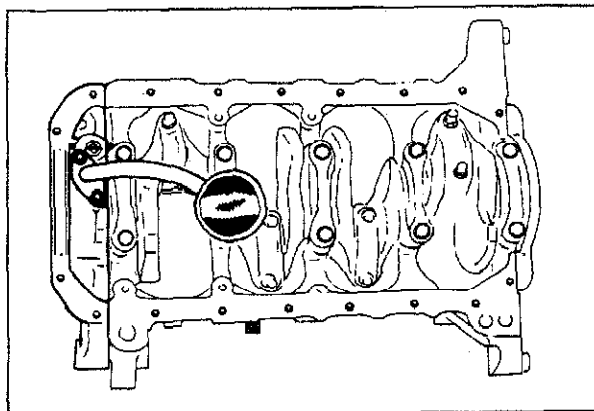

63U01X-107

### Oil Strainer

Install the oil strainer along with a new gasket.

#### Tightening torque:

8—11 N·m (0.8—1.1 m·kg, 69—95 in·lb)

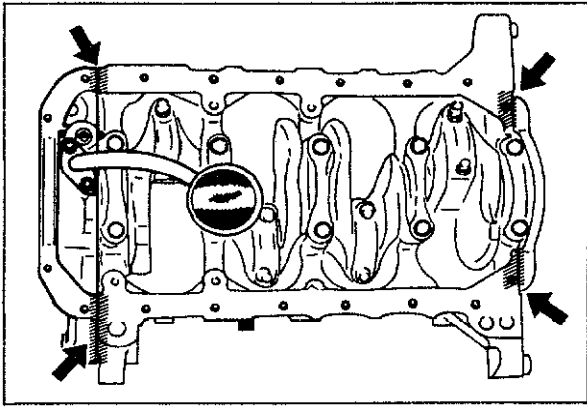

83U01B-076

## Oil Pan

1. Apply sealant to the places indicated by the arrows in the figure after cleaning the cylinder block surface.

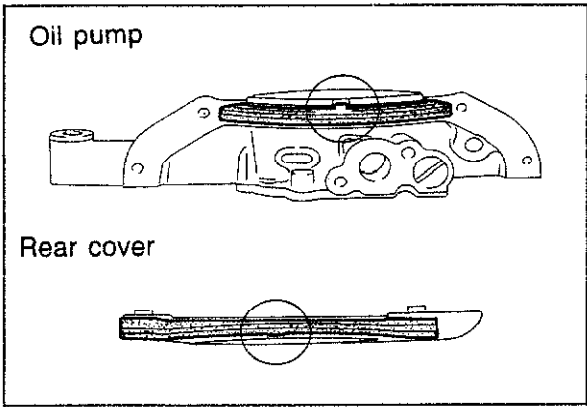

83U01B-077

2. Install the gaskets onto the oil pump body and rear cover with the projections in the notches as shown.

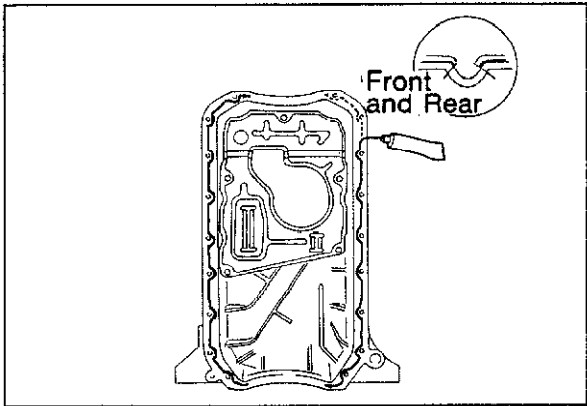

83U01B-078

3. Clean the oil pan contact surface.

### Caution

**Do not leave any dirt or oil on it.**

4. Apply silicone sealant to the oil pan continuously with the bead of **2.5—3.5 mm (0.0984—0.1378 in)**, rimming the surface inside the bolt holes as shown.

### Caution

**After the sealant is applied, the pan must be secured within 30 minutes.**

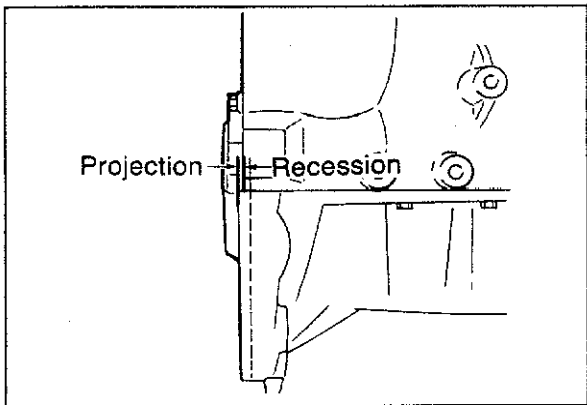

83U01B-079

5. Install the oil pan.

### Caution

**Oil pan projection and recession from the end of the cylinder block must not be more than 1.5 mm (0.06 in)**

6. Tighten the bolts gradually in three steps.

### Tightening torque:

**8—11 N·m (0.8—1.1 m·kg, 69—95 in·lb)**

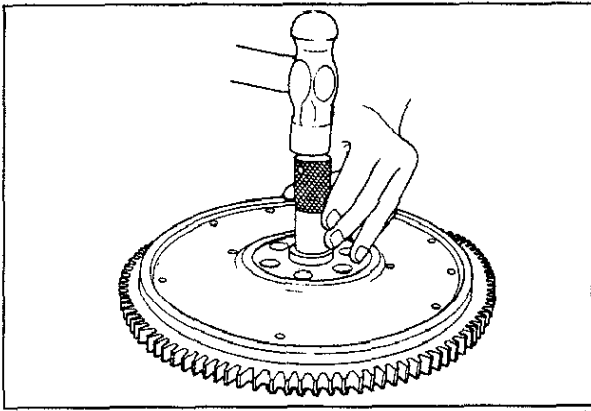

83U01A-107

### Flywheel (MTX)

1. Tap the pilot bearing in with a suitable pipe and hammer.
2. Apply **sealant** to the flywheel bolts.

#### Caution

If reinstalling flywheel bolts, clean threads to remove old sealant, apply new sealant and tighten to specification. If old sealant can not be removed, replace bolts.

3. Install the flywheel, with the **SST** while tightening.

#### Tightening torque:

96—103 N·m (9.8—10.5 m·kg, 71—76 ft·lb)

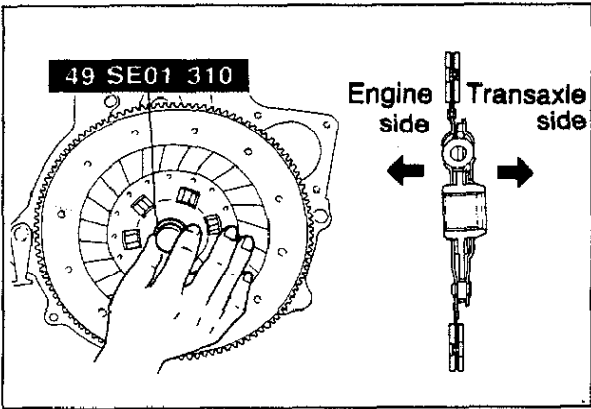

83U01B-109

### Clutch Disc and Clutch Cover

Install the clutch disc and clutch cover with the **SST**, and tighten the clutch cover.

#### Tightening torque:

18—26 N·m (1.8—2.7 m·kg, 13—20 ft·lb)

#### Note

Follow the clutch disc installation directions exactly (See Section 6).

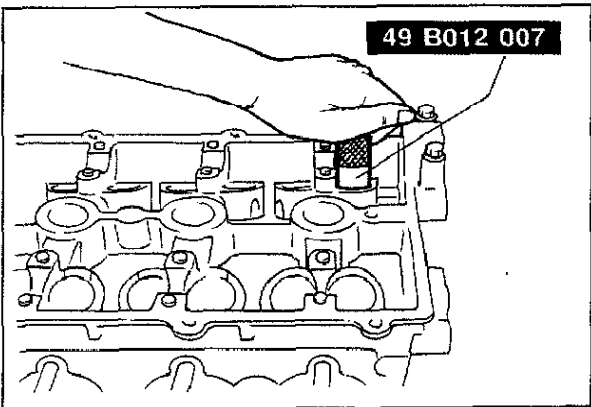

83U01X-127

### Valve Seal

1. Apply engine oil to the inner surface of the new valve seal.
2. Install the valve seal onto the valve guide with the **SST**.

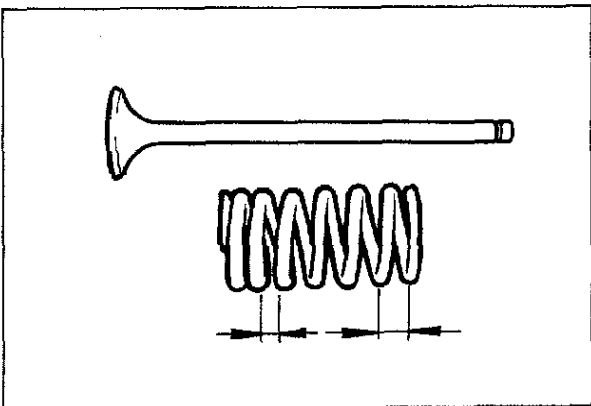

63U01X-091

### Valve and Valve Spring

1. Install the lower spring seat.
2. Install the valve.
3. Install the valve spring and the upper spring seat.

#### Note

Install the spring with its narrow pitch end toward the cylinder head.



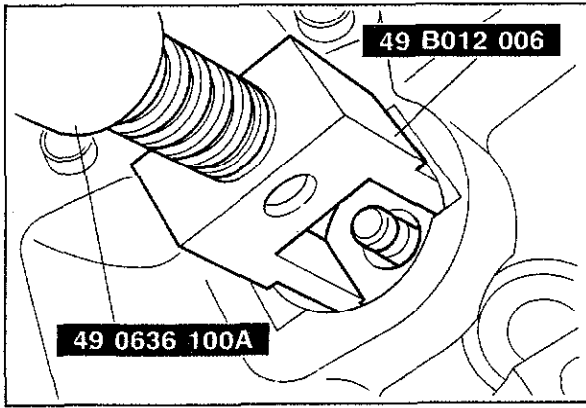

83U01X-128

4. Install the spring retainer after compressing the valve spring with the **SST**.

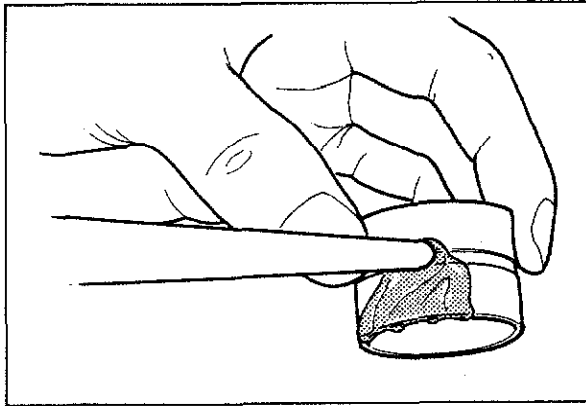

### HLA

1. Apply engine oil to the sliding surface.

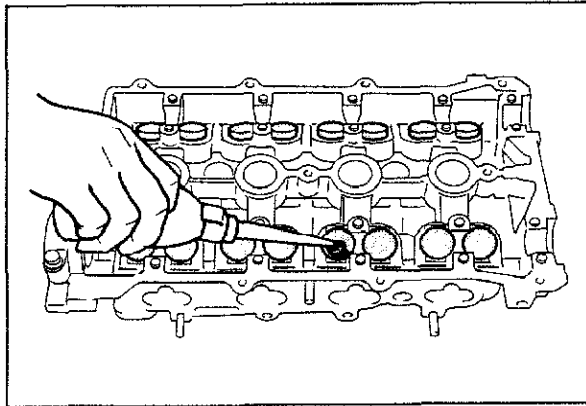

2. Install the HLA in the position from which they were removed.
3. Check for free movement.

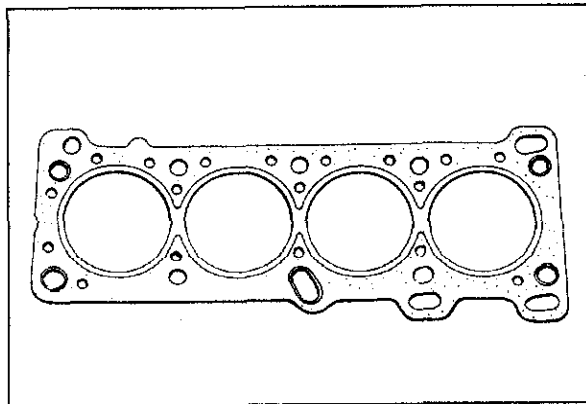

### Cylinder Head

1. Thoroughly remove all dirt and grease from the top of the cylinder block with a rag.
2. Use a new cylinder head gasket in position.

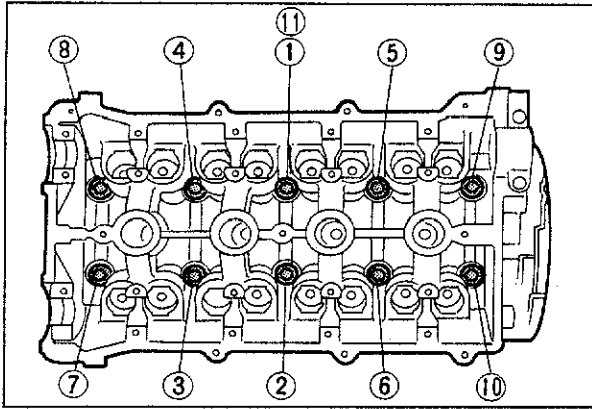

63U01X-112p

3. Install the cylinder head.

**Tightening torque:**

76—81 N·m (7.7—8.3 m·kg, 56—60 ft·lb)

**Caution**

Tightening the bolts must be done gradually and in the order shown in the figure.

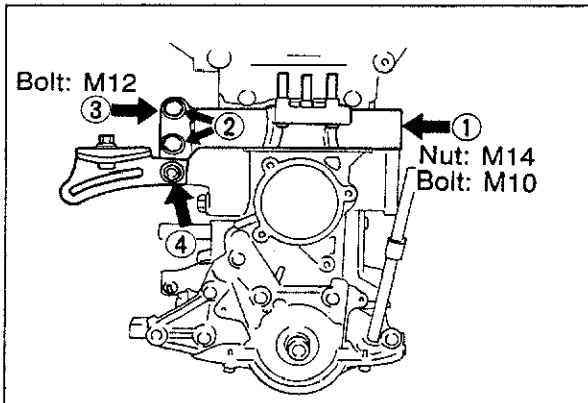

83U01B-082

**Engine Bracket and Mount Arm**

Install the engine bracket and mount arm.

**Tightening torque:**

Bolt ①: 47—66 N·m  
(4.8—6.7 m·kg, 35—48 ft·lb)

Bolt ②: 60—85 N·m  
(6.1—8.7 m·kg, 44—63 ft·lb)

Bolt ③: 93—117 N·m  
(9.5—11.9 m·kg, 69—86 ft·lb)

Bolt ④: 37—52 N·m  
(3.8—5.3 m·kg, 27—38 ft·lb)

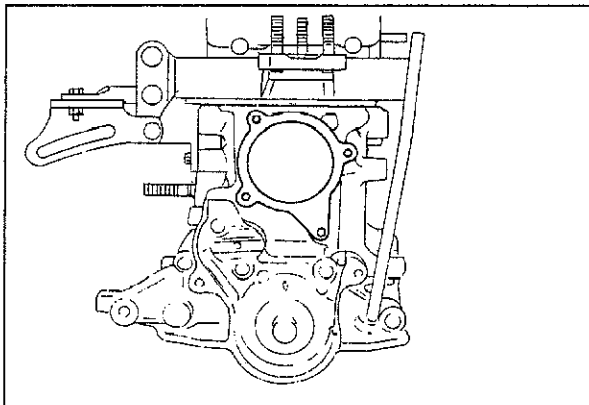

63G01C-084

**Water Pump**

1. Remove any dirt or old gasket from the water pump mounting surface.
2. Use a new water pump gasket in position.

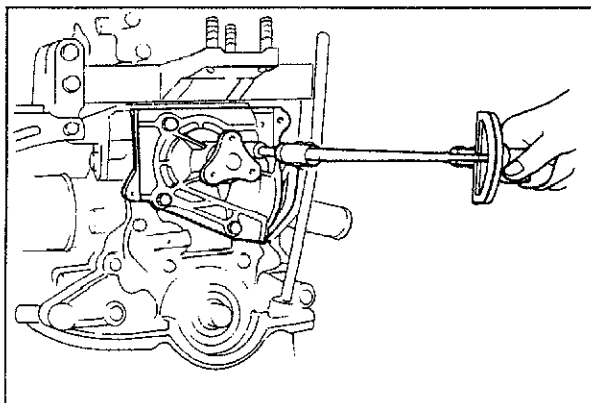

4BG01A-169p

3. Install the water pump.

**Tightening torque:**

19—26 N·m (1.9—2.6 m·kg, 14—19 ft·lb)

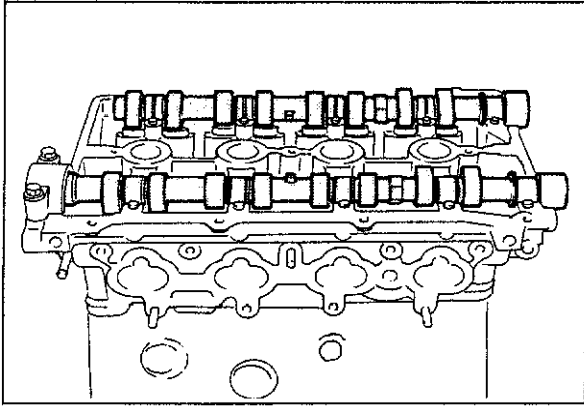

63G01C-087

## Camshaft

Apply engine oil to the journals, set the camshaft in position.

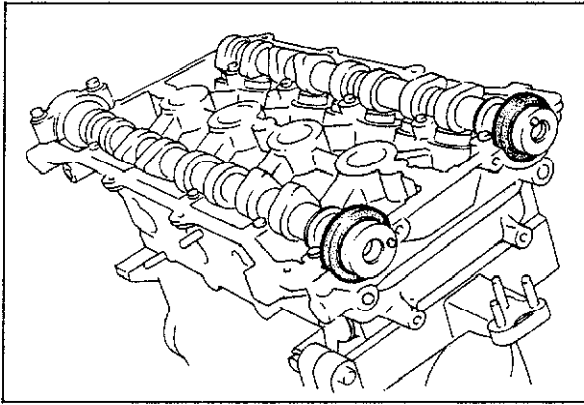

63G01C-088

## Camshaft Oil Seal

1. Apply a thin coat of engine oil to the camshaft oil seal and cylinder head.
2. Install the camshaft oil seal.

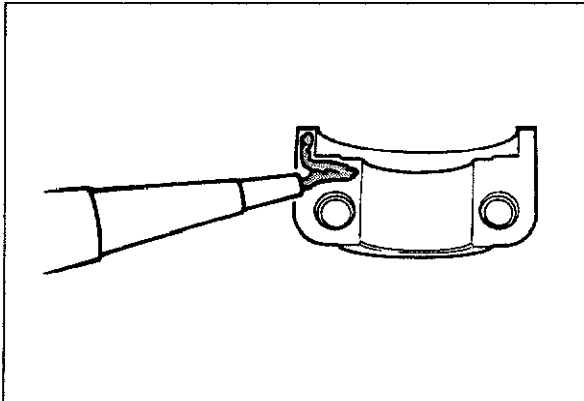

83U01B-083

3. Apply a thin coat of sealant to the front camshaft cap surface.

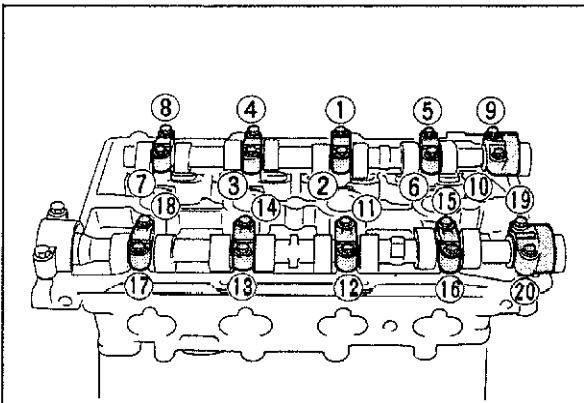

63G01C-090

4. Install the camshaft caps, tighten the camshaft cap bolts gradually in the order shown in the figure.

**Tightening torque: 11—14 N·m  
(1.15—1.45 m·kg, 100—126 in·lb)**

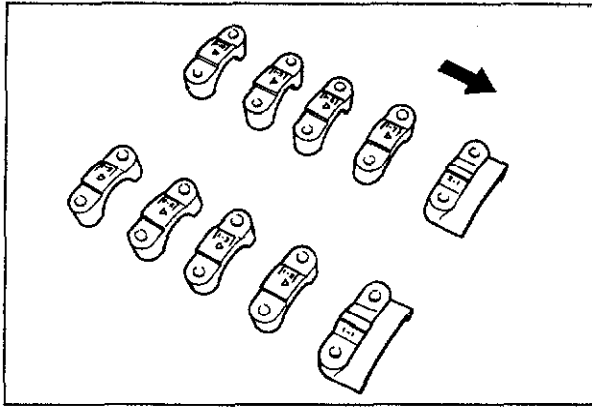

63G01C-091

**Note**

Install the camshaft cap according to the cap number and arrow mark.

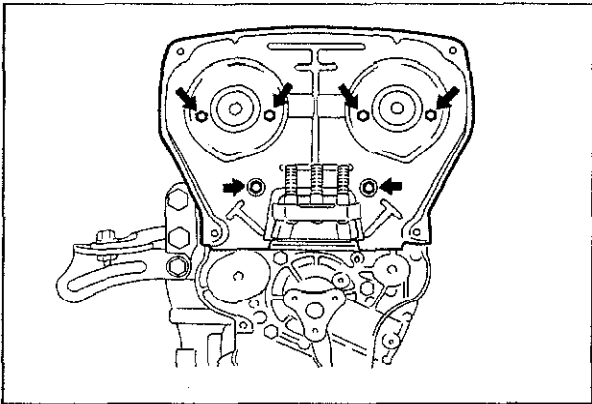

83U01B-084

**Seal Plate**

Install the seal plate.

**Tightening torque:**

8—11 Nm (0.8—1.1 m-kg, 69—95 in-lb)

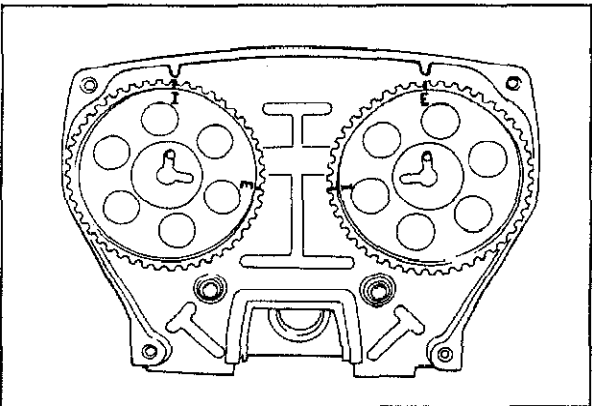

83U01B-085

**Camshaft Pulley**

1. Install the camshaft pulley.

**Caution**

For the exhaust side camshaft pulley, install the pulley with the "E" mark straight up. For the intake side camshaft pulley, install the pulley with the "I" mark straight up.

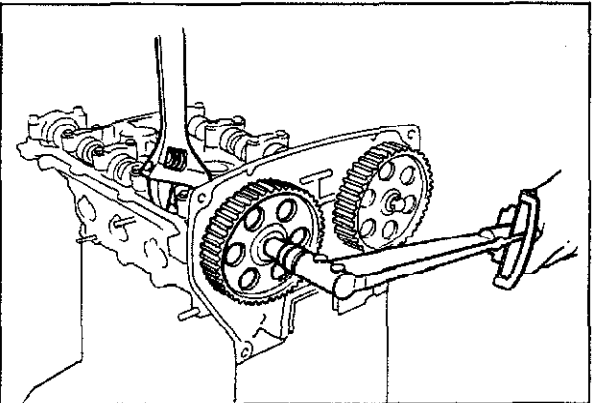

83U01B-086

2. Tighten the camshaft pulley bolt.

Hold the camshaft using a suitable wrench on the journal, as shown.

**Tightening torque:**

49—61 N-m (5.0—6.2 m-kg, 36—45 ft-lb)

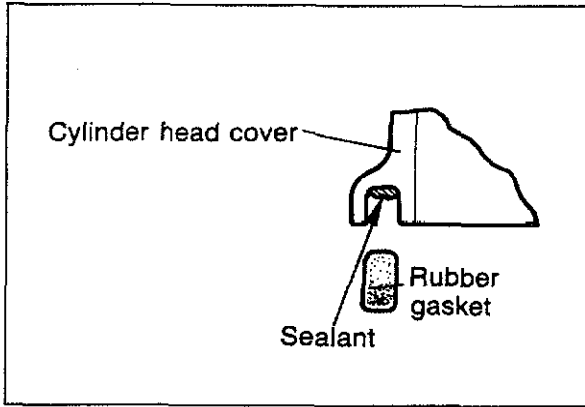

63U01X-131

## Cylinder Head Cover

1. Apply a coat of sealant in the groove as shown.
2. Place the gasket in position.

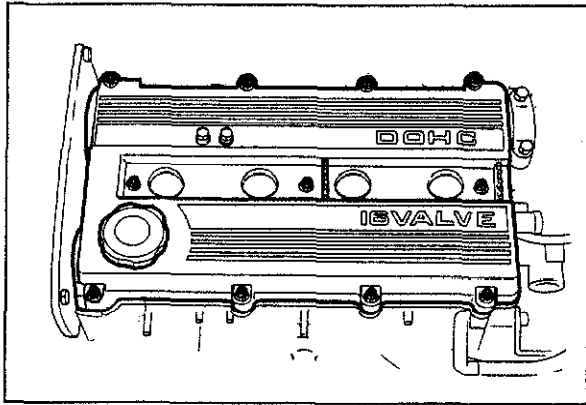

83U01B-087

3. Install the cylinder head cover with new seal washers.

### Tightening torque:

**3—4 N·m (0.3—0.4 m·kg, 26—35 in·lb)**

4. Install the filler cap and the ventilation hose.

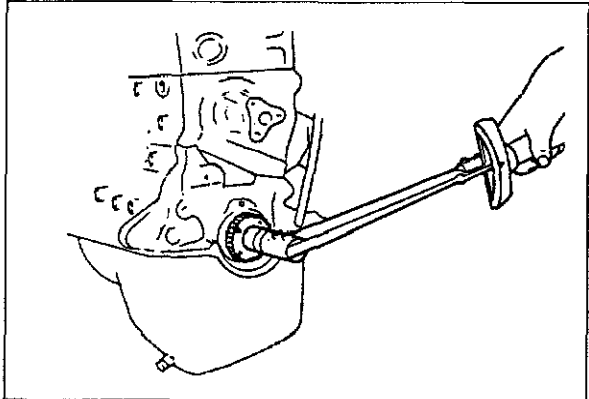

83U01A-113

## Timing Belt Pulley

1. Reverse the direction of the **SST** (49 E301 060).
2. Install the timing belt pulley and key.
3. Apply sealant to the timing belt pulley bolt then tighten it.

**Tightening torque: 108—128 N·m  
(11.0—13.0 m·kg, 80—94 ft·lb)**

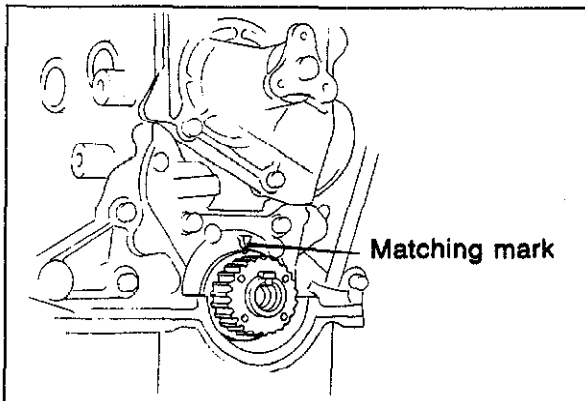

83U01X-129

4. Release the **SST** (49 E301 060).
5. Turn the crankshaft so that the timing mark on the oil pump body is aligned with the groove.

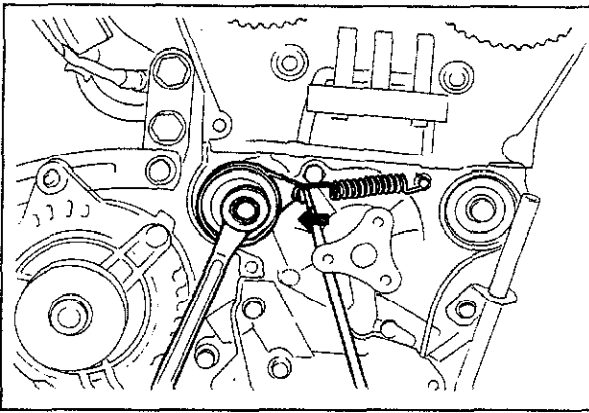

83U01B-088

### Idler Puller

Install the idler puller.

### Tightening torque:

**37—52 N·m (3.8—5.3 m·kg, 27—38 ft·lb)**

### Timing Belt Tensioner

1. Install the timing belt tensioner.
2. Install the tensioner spring.
3. Temporarily secure the tensioner so the spring is fully extended.

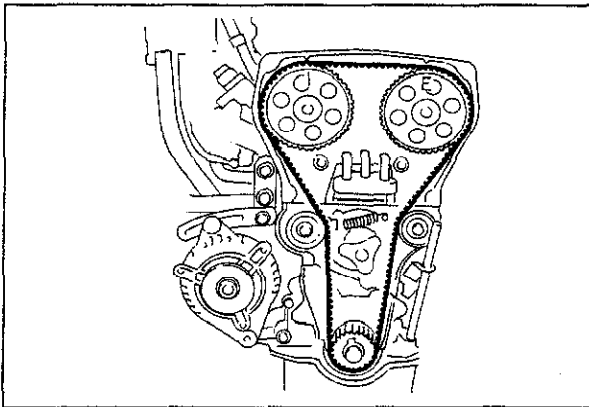

63U01X-124

### Timing Belt

1. Align crankshaft and camshaft timing marks. (inlet "I" marks, exhaust "E" mark)
2. Install the timing belt. (Keep the right side of belt as tight as possible)

### Caution

- a) The timing belt must be reinstalled in the direction of previous rotation if it is reused.
- b) Be sure that there is no oil, grease, or dirt on the timing belt.

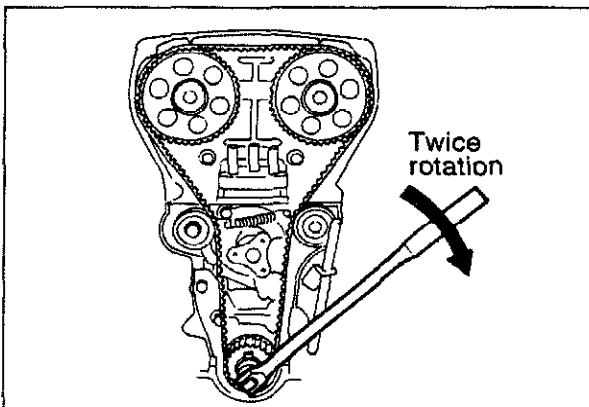

83U01B-089

3. Turn the crankshaft twice in the direction of rotation. (Clockwise)
4. Check that the timing marks are correctly aligned. If not, repeat steps 1—3.
5. Loosen the tensioner lock bolt and apply tension to the belt.

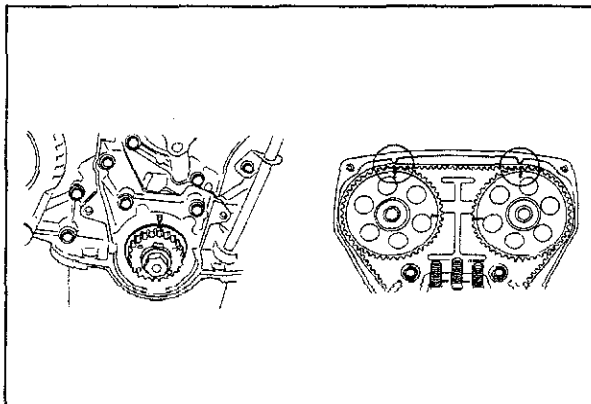

63U01X-126p

6. Tighten the timing belt tensioner to specification.

### Tightening torque:

**37—52 N·m (3.8—5.3 m·kg, 27—38 ft·lb)**

7. Turn the crankshaft twice in the direction of rotation and check the matching marks for alignment.

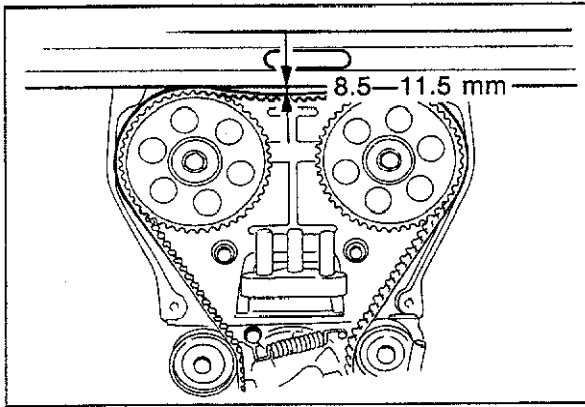

83U01B-090

8. Measure the tension between the intake side camshaft pulley and the exhaust side camshaft pulley. If the timing belt tension is not correct, temporarily secure the tensioner lock bolt so the spring is fully extended and repeat steps 1—7 above or replace the tensioner spring.

**Deflection:**

**8.5—11.5 mm (0.33—0.45 in)  
/ 95 N (10 kg, 22 lb)**

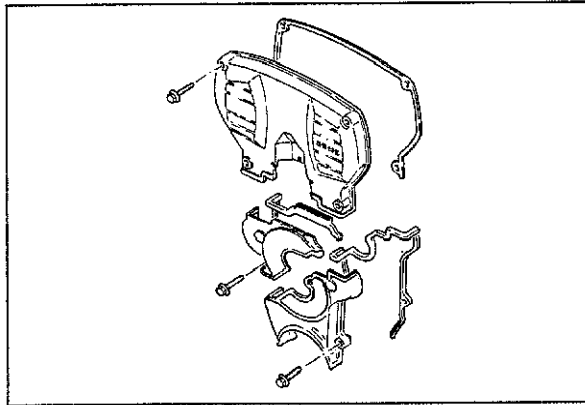

63G01C-095

**Timing Belt Cover**

Install the lower, middle and upper timing belt cover and a new gasket.

**Tightening torque:**

**8—11 N·m (0.8—1.1 m·kg, 69—95 in·lb)**

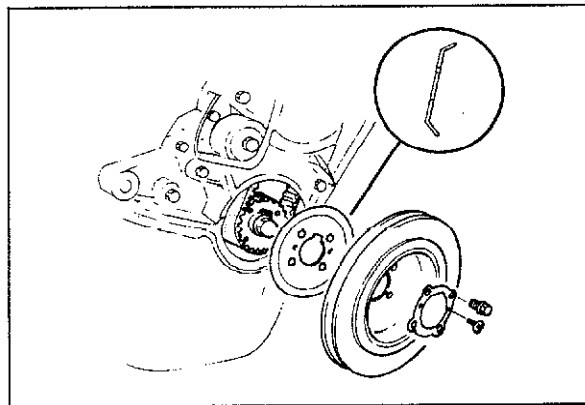

83U01B-091

**Crankshaft Pulley**

Install the crankshaft pulley and baffle plate.

**Tightening torque: 12—17 N·m**

**(1.25—1.75 m·kg, 109—152 in·lb)**

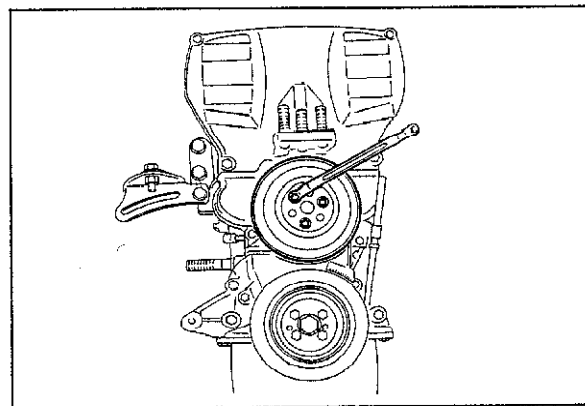

83U01B-092

**Water Pump Pulley**

Install the Water pump pulley.

**Tightening torque:**

**8—11 N·m (0.8—1.1 m·kg, 69—95 in·lb)**

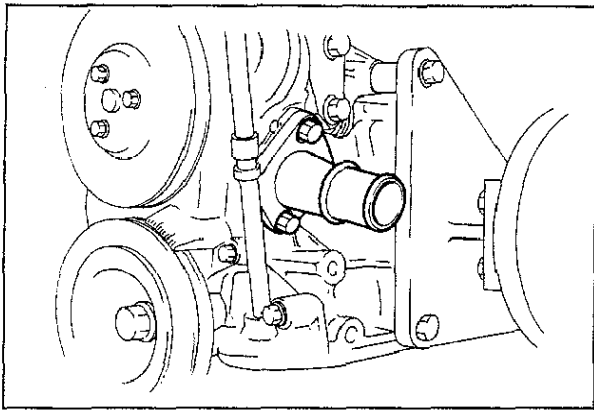

4BG01A-203

### Coolant Inlet Pipe

Install the coolant inlet pipe and a new gasket.

#### Tightening torques:

19—26 N·m (1.9—2.6 m·kg, 14—19 ft·lb)

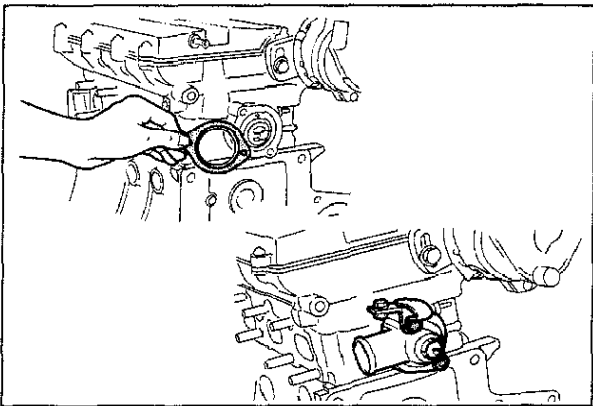

4BG01A-198p

### Thermostat and Thermostat Cover

1. Install the thermostat with the jiggle pin facing upward.
2. Install the thermostat cover and gasket.

#### Tightening torque:

19—26 N·m (1.9—2.6 m·kg, 14—19 ft·lb)

#### Caution

The printed side of the gasket must face the thermostat.

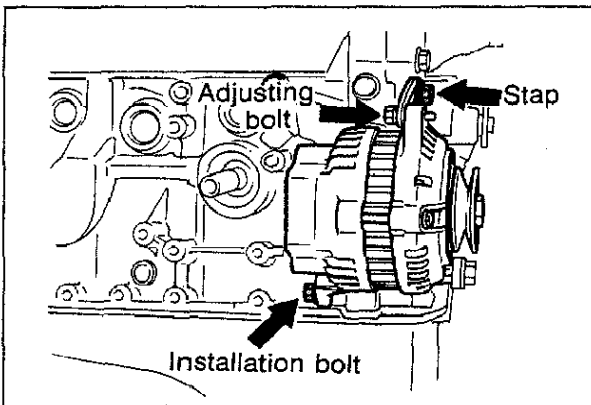

83U01B-108

### Alternator

1. Install the alternator strap.

#### Tightening torque:

37—52 N·m (3.8—5.3 m·kg, 27—38 ft·lb)

2. Install the alternator and alternator drive belt. Loosely tighten the alternator installation bolt.
3. Adjust the drive belt deflection by referring to page 1B—6.

#### Tightening torque:

##### Alternator installation bolt:

37—52 N·m (3.8—5.3 m·kg, 27—38 ft·lb)

##### Belt adjusting bolt:

19—26 N·m (1.9—2.6 m·kg, 14—19 ft·lb)

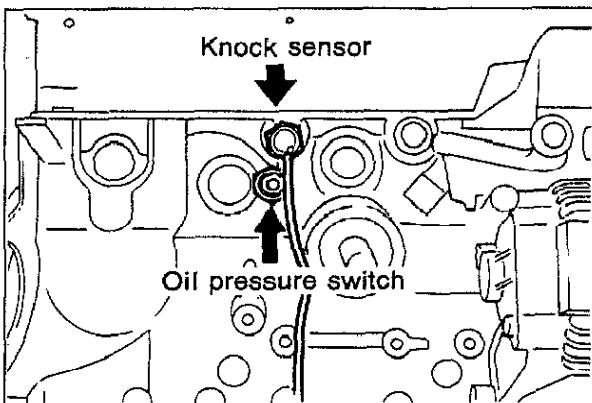

83U01B-093

### Oil Pressure Switch

Install the oil pressure switch.

#### Tightening torque: 12—18 N·m

(1.2—1.8 m·kg, 104—156 in·lb)

### Knock Sensor

Install the knock sensor.

#### Tightening torque:

20—34 N·m (2.0—3.5 m·kg, 14—25 ft·lb)



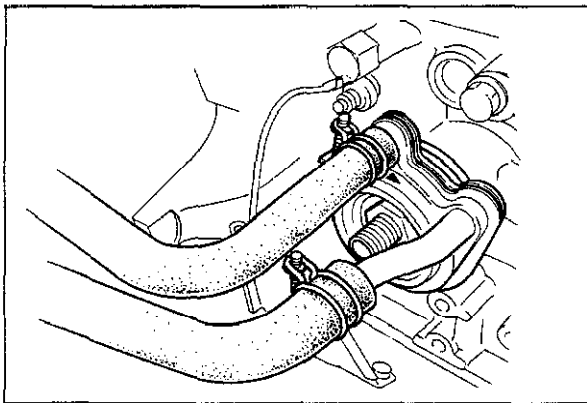

83U01B-094

### Oil Cooler

Apply engine oil to the oil cooler "O" ring and install the oil cooler to cylinder block.

### Tightening torque:

29—39 N·m (3.0—4.0 m·kg, 22—29 ft·lb)

### Note

The oil cooler must be installed so the ▲ mark faces upward.

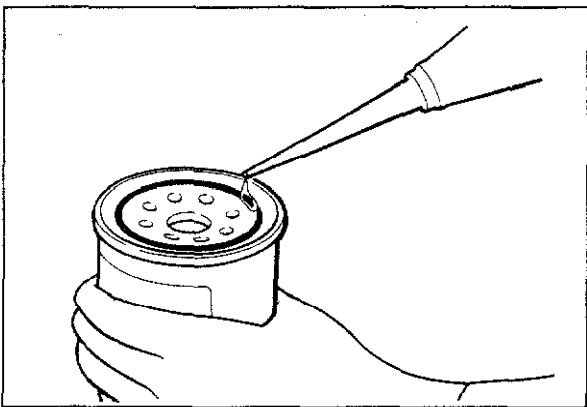

63G01C-099

### Oil Filter

Apply engine oil to the oil filter "O" ring and install the filter, tighten thoroughly by hand.

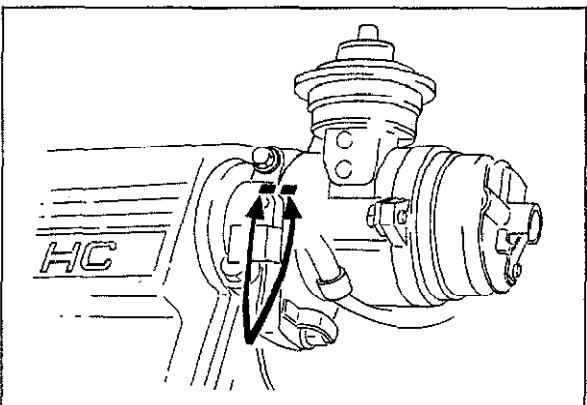

83U01A-119

### Distributor

1. Apply engine oil to the "O" ring, and position it on the distributor.
2. Apply engine oil to the drive gear.
3. Install the distributor with the blade into the camshaft groove.
4. Temporarily, loosely tighten the distributor installing bolt.

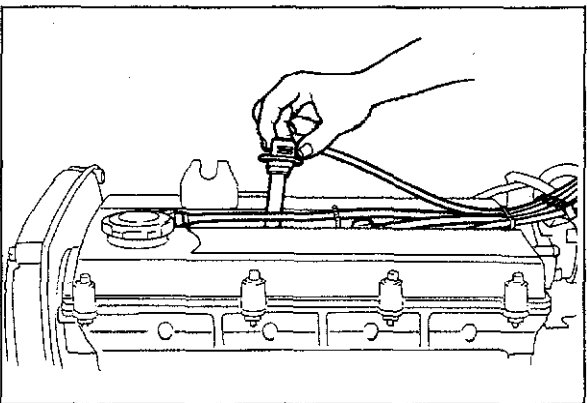

4BG01A-200

### Spark Plug and High Tension Lead

1. Install the spark plugs.

### Tightening torque:

15—23 N·m (1.5—2.3 m·kg, 11—17 ft·lb)

2. Connect the high tension leads.

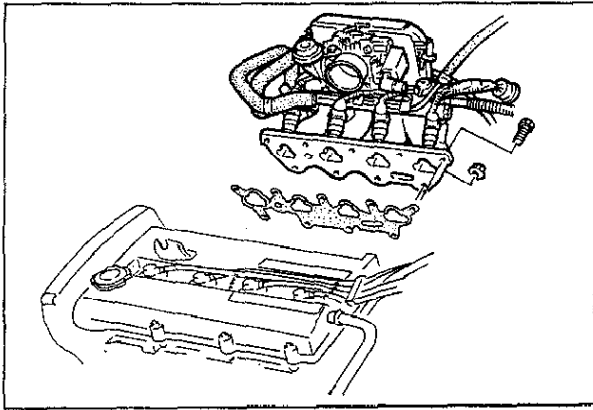

63U01X-136

### Intake Manifold Assembly

1. Install the intake manifold assembly and new gasket.

#### Tightening torque:

19—26 N·m (1.9—2.6 m·kg, 14—19 ft·lb)

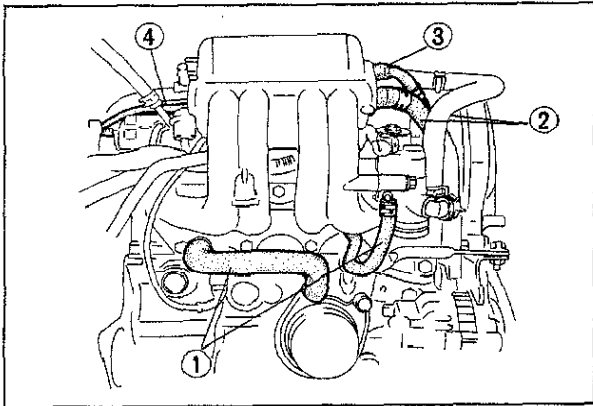

83U01B-095

2. Connect the following hoses.

- (1) Water hoses
- (2) Air hose
- (3) Ventilation hose
- (4) Vacuum hose

#### Caution

Hose clamp must be reinstalled in the original position on the hose.

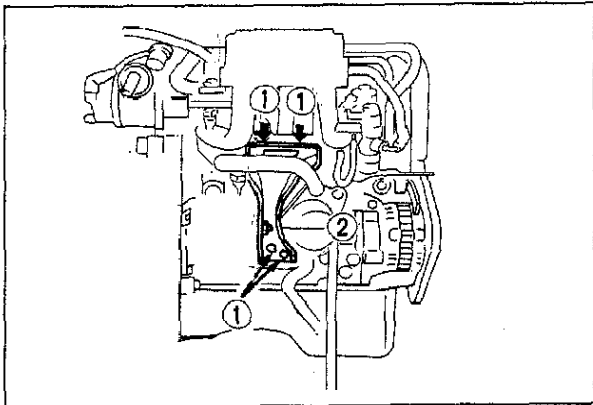

83U01B-096

### Surge Tank Bracket

Install the surge tank bracket.

#### Tightening torque:

31—46 N·m (3.2—4.7 m·kg, 22—34 ft·lb)

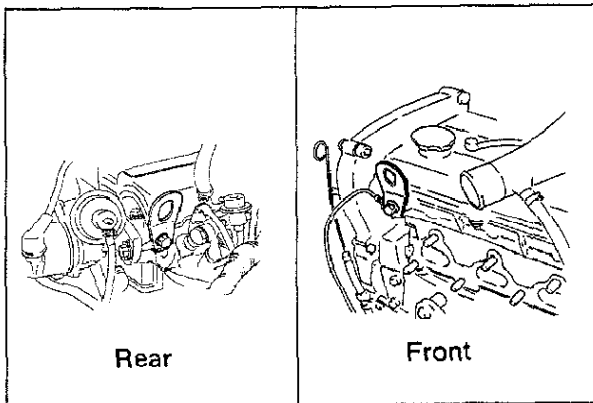

63U01X-134

### Engine Hanger

Install the front and rear engine hangers.

#### Tightening torque:

Front: 37—52 N·m  
(3.8—5.3 m·kg, 27—38 ft·lb)

Rear: 37—52 N·m  
(3.8—5.3 m·kg, 27—38 ft·lb)

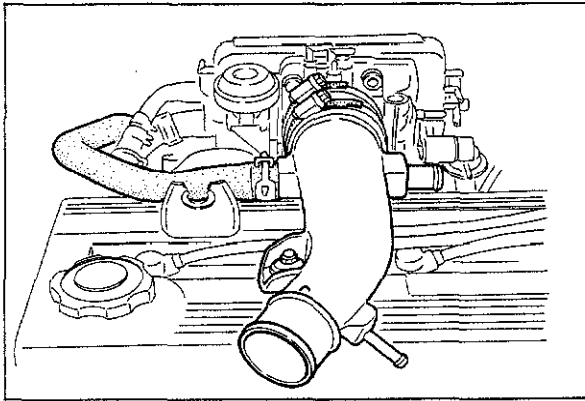

83U01B-097

### Air Intake Pipe

1. Install the air intake pipe.

#### Tightening torque:

**8—11 N·m (0.8—1.1 m·kg, 69—95 in·lb)**

2. Connect the air hose.

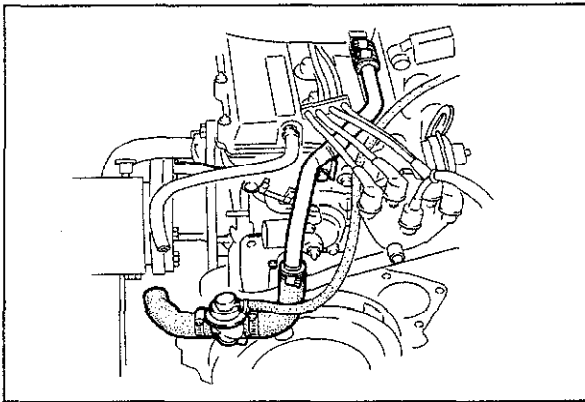

83U01B-098

### Air Bypass Valve and Hoses

- Install the air bypass valve and hoses.

#### Tightening torque:

**19—26 N·m (1.9—2.6 m·kg, 14—19 ft·lb)**

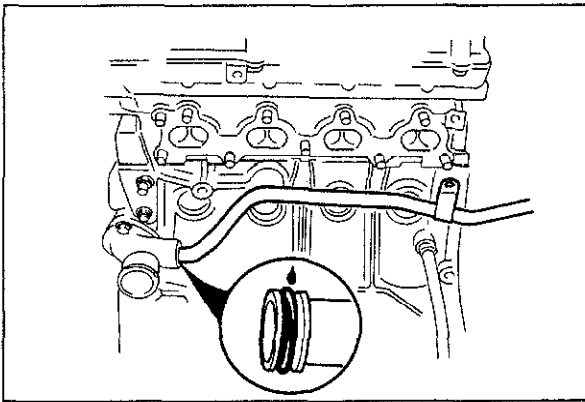

83U01B-099

### Coolant Bypass Hose

1. Apply a coat of long life coolant to the "O" ring.
2. Install the coolant bypass hose.

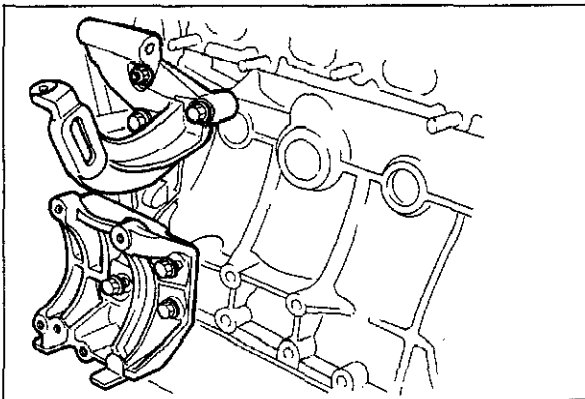

83U01A-127

### Power Steering Pump Bracket

- Install the power steering pump bracket.

#### Tightening torque:

**47—66 N·m (4.8—6.7 m·kg, 35—48 ft·lb)**

### Air Conditioner Compressor Bracket

- Install the air conditioner compressor bracket.

#### Tightening torque:

**37—52 N·m (3.8—5.3 m·kg, 27—38 ft·lb)**

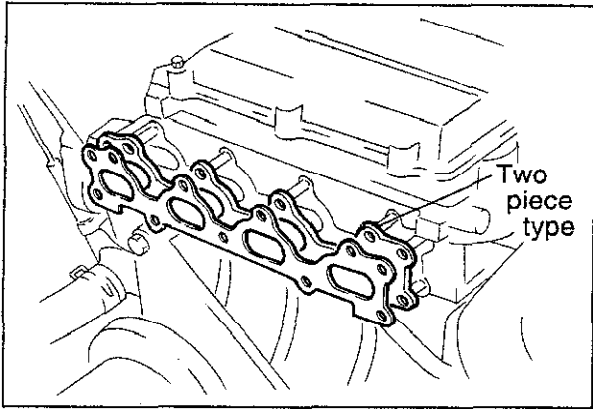

83U01B-100

## Exhaust Manifold and Turbocharger Assembly

1. Remove the engine from the engine hanger and engine stand.
2. Install the exhaust manifold gasket.

### Note

**Two piece type gasket must be installed onto cylinder head side.**

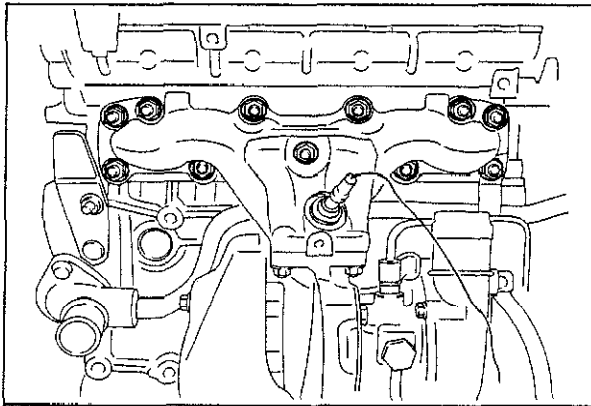

83U01B-101

3. Install the exhaust manifold and turbo charger assembly.

### Tightening torque:

**39—57 N·m (4.0—5.8 m·kg, 29—42 ft·lb)**

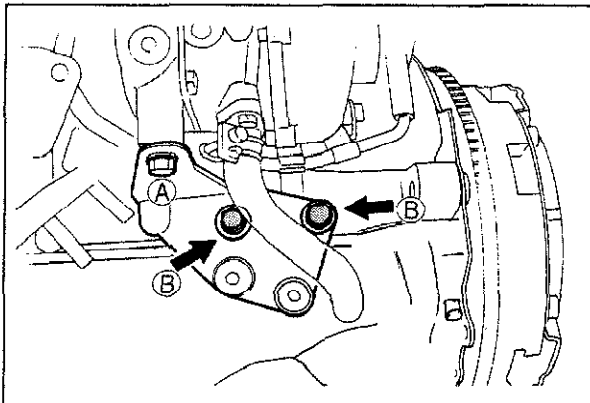

83U01B-102

4. Install the turbocharger bracket.

### Tightening torque:

**Bolt A: 25—32 N·m**

**(2.5—3.3 m·kg, 18—24 ft·lb)**

**Bolt B: 43—61 N·m**

**(4.4—6.2 m·kg, 32—45 ft·lb)**

5. Connect the oil return hose.

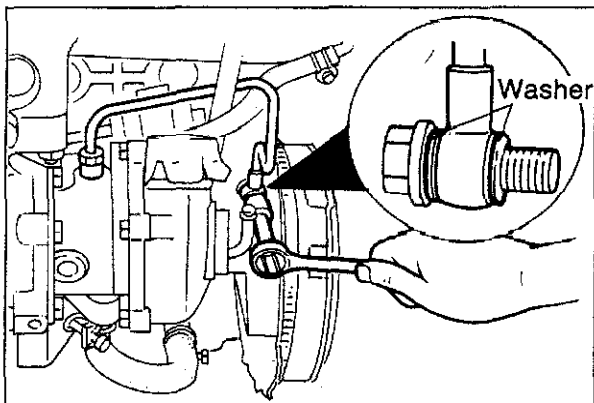

83U01B-103

6. Connect the oil pipe.

### Tightening torque: 12—18 N·m

**(1.2—1.8 m·kg, 104—156 in·lb)**

7. Connect the water hose.

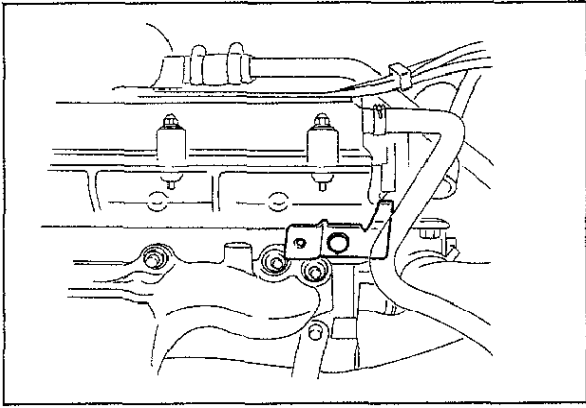

83U01B-104

### Intake Air Hose Bracket

Install the intake air hose bracket.

#### Tightening torque:

19—26 N·m (1.9—2.6 m·kg, 14—19 ft·lb)

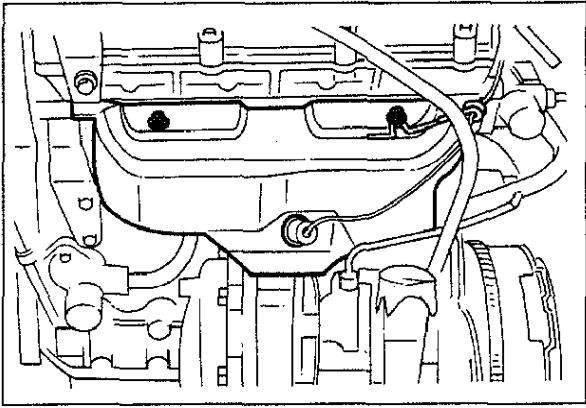

83U01B-105

### Exhaust Manifold Insulator

Install the exhaust manifold insulator and wire clip.

#### Tightening torque:

19—26 N·m (1.9—2.6 m·kg, 14—19 ft·lb)

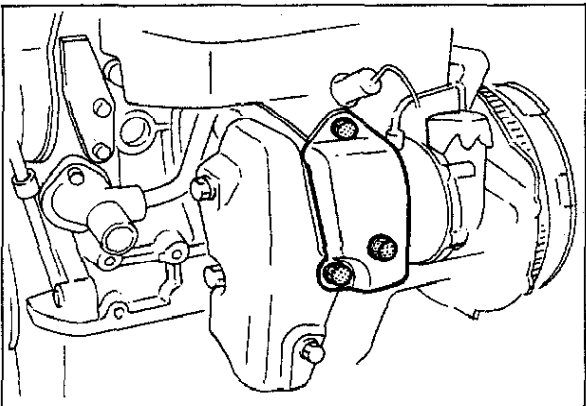

83U01B-106

### Turbocharger Insulator

Install the turbocharger insulator.

#### Tightening torque:

19—26 N·m (1.9—2.6 m·kg, 14—19 ft·lb)

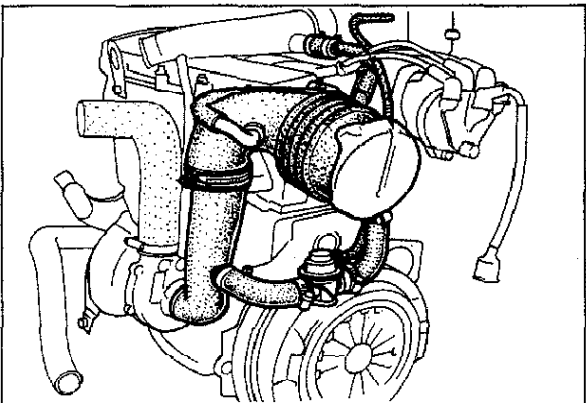

83U01B-107

### Air Hose

Install the air hose.

### Oil Level Gauge

Install the oil level gauge.

# LUBRICATION SYSTEM (B6 EGI)

<b>OUTLINE</b> .....	2A— 2
STRUCTURAL VIEW.....	2A— 2
SPECIFICATIONS.....	2A— 3
<b>TROUBLESHOOTING GUIDE</b> .....	2A— 3
<b>OIL FILTER</b> .....	2A— 4
REPLACEMENT.....	2A— 4
<b>OIL PAN</b> .....	2A— 5
REMOVAL AND INSTALLATION.....	2A— 5
INSPECTION.....	2A— 6
<b>OIL PUMP</b> .....	2A— 7
REMOVAL AND INSTALLATION.....	2A— 7
DISASSEMBLY AND ASSEMBLY.....	2A— 8
INSPECTION.....	2A— 9
<b>OIL PRESSURE</b> .....	2A— 9
INSPECTION.....	2A— 9

## OUTLINE

### STRUCTURAL VIEW

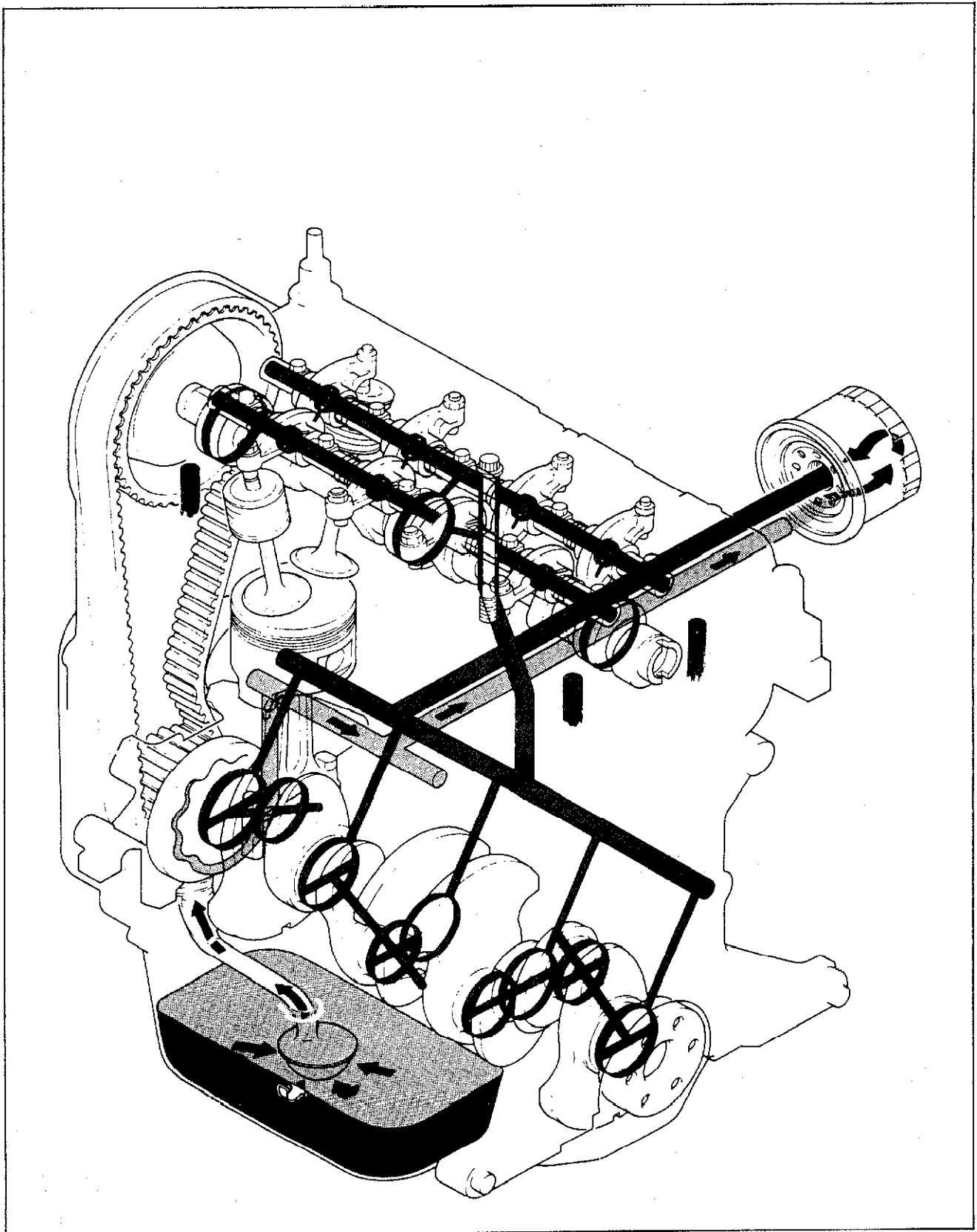

63U02X-002

## SPECIFICATIONS

Lubricating system		Force-fed type
Oil pump	Type	Trochoid gear type
	Oil pressure kPa (kg/cm <sup>2</sup> , psi)	343—441 (3.5—4.5, 50—64)
Oil filter	Type	Full-flow type, paper element
	Relief-valve opening pressure kPa (kg/cm <sup>2</sup> , psi)	98 (1.0, 14)
Oil warning pressure kPa (kg/cm <sup>2</sup> , psi)		29 (0.3, 4.3)
Oil capacity	Total liters (US qt, Imp qt)	3.4 (3.6, 3.0)
	Oil pan liters (US qt, Imp qt)	3.0 (3.2, 2.6)
	Oil filter liters (US qt, Imp qt)	0.3 (0.32, 0.26)
Engine oil		API service SD, SE, SF

83U02A-002

## Recommended SAE viscosity numbers

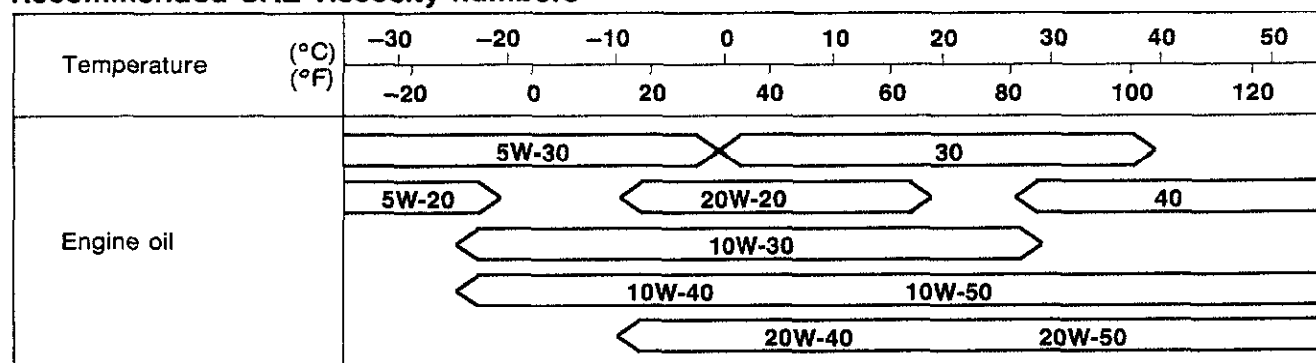

76U02X-003

Temperature range anticipated before next oil change, °C(°F)

## TROUBLESHOOTING GUIDE

Problem	Possible Cause	Remedy	Page
<b>Oil leakage</b>	Loose drain plug	Tighten or replace	2A— 6
	Faulty seal at oil pan and cylinder block	Repair	2A— 6
	Damaged cylinder head cover	Refer to Section 1A	—
	Loose oil pump body bolt, cylinder head cover bolt, or oil pan bolt	Tighten	2A— 5 2A— 8
	Damaged front housing gasket, or cylinder head gasket	Refer to Section 1A	—
	Faulty oil seal(s)	Replace	—
	Loose oil filter	Tighten	2A— 4
<b>Oil pressure drop</b>	Loose or damaged oil pressure switch	Tighten or replace	—
	Oil leak	As described above	—
	Insufficient oil	Add oil	—
	Worn and/or damaged oil pump gear	Replace	2A— 8
	Worn plunger (inside oil pump) or weak spring	Replace	2A— 8
<b>Warning lamp illuminates while engine is running</b>	Clogged oil strainer	Clean	2A— 7
	Excessive lubrication clearance between main bearing or connecting rod bearing	Refer to Section 1A	—
	Oil pressure drop	As described above	—
<b>Warning lamp illuminates while engine is running</b>	Malfunition of oil pressure switch	Refer to Section 15	—
	Problem in electrical system	Refer to Section 15	—

83U02A-003



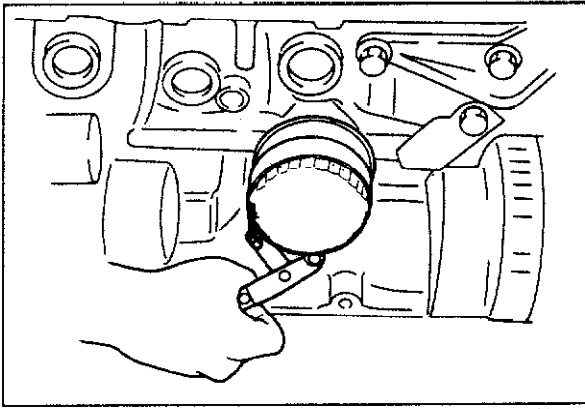

63U02X-006

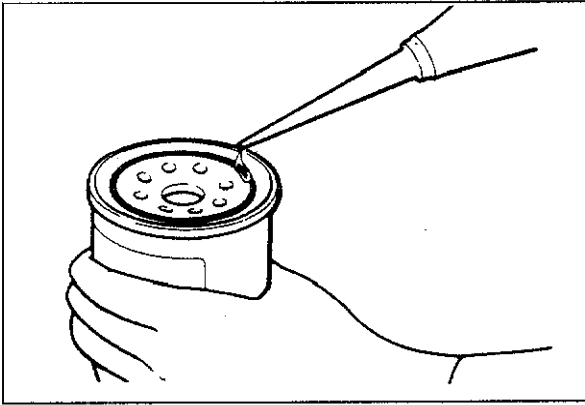

63U02X-007

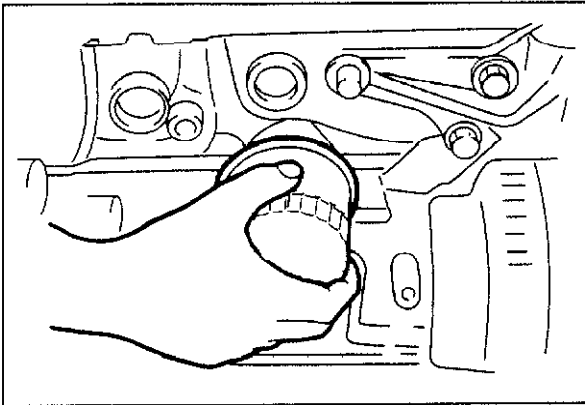

63U02X-008

## OIL FILTER

### REPLACEMENT

1. Remove the oil filter with an oil filter wrench.
2. Apply a small amount of engine oil to the O-ring of the new oil filter.
3. Fully tighten the oil filter by hand.
4. Add engine oil to the correct level.
5. After installing the filter, check to be sure that there is no oil leakage while the engine is running.
6. Re-check the oil level using the dipstick.

**OIL PAN****REMOVAL AND INSTALLATION**

1. Disconnect the battery negative cable.
2. Drain the engine oil.
3. Remove the parts in the numbered sequence shown in the figure.
4. Install in the reverse order of removal.

83U02A-004

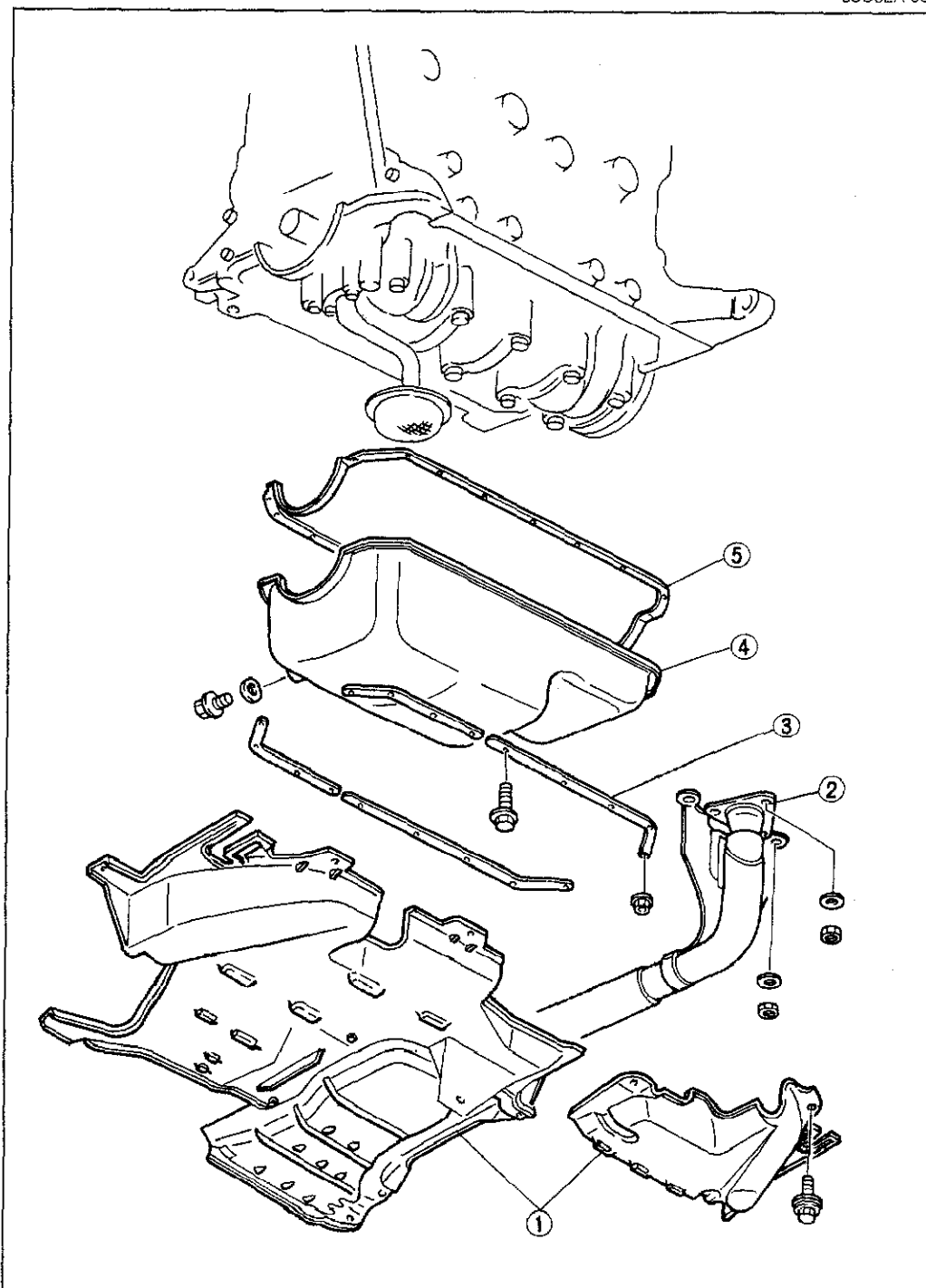

1. Engine under covers
2. Exhaust pipe
3. Stiffener
4. Oil pan
5. Gasket

83U02A-005

**Steps after installation**

1. Add the prescribed amount of oil.
2. Check for oil leakage after starting the engine.

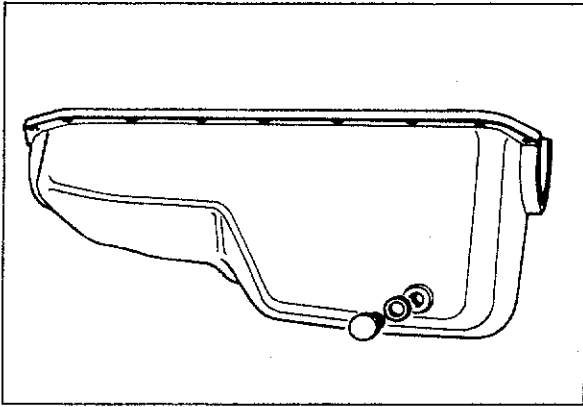

63U02X-013

## INSPECTION

Check the following points. Repair or replace if necessary:

1. Cracks, deformation, damage (at bolt locations)
2. Damaged drain plug threads.

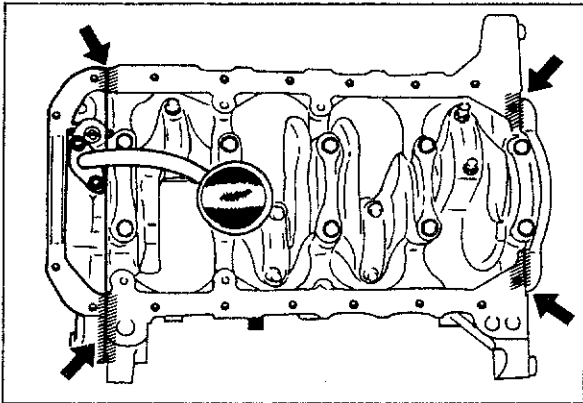

83U02A-006

## Installation Note

1. Apply sealant to the places indicated by the arrows in the figure after cleaning the surface.

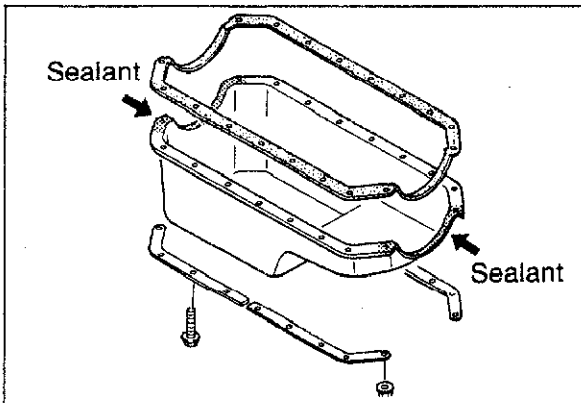

83U02A-007

2. Apply sealant to the shaded area as shown in the figure after cleaning the surface.
3. Install the oil pan along with new gasket and stiffener.

## Tightening torque:

**6—9 N·m (0.6—0.9 m·kg, 52—78 in·lb)**

# OIL PUMP

## REMOVAL AND INSTALLATION

1. Disconnect the battery negative cable.
2. Drain the engine oil.
3. Remove each part in the numbered sequence shown in the figure.
4. Install in the reverse order of removal.

4BG02X-038

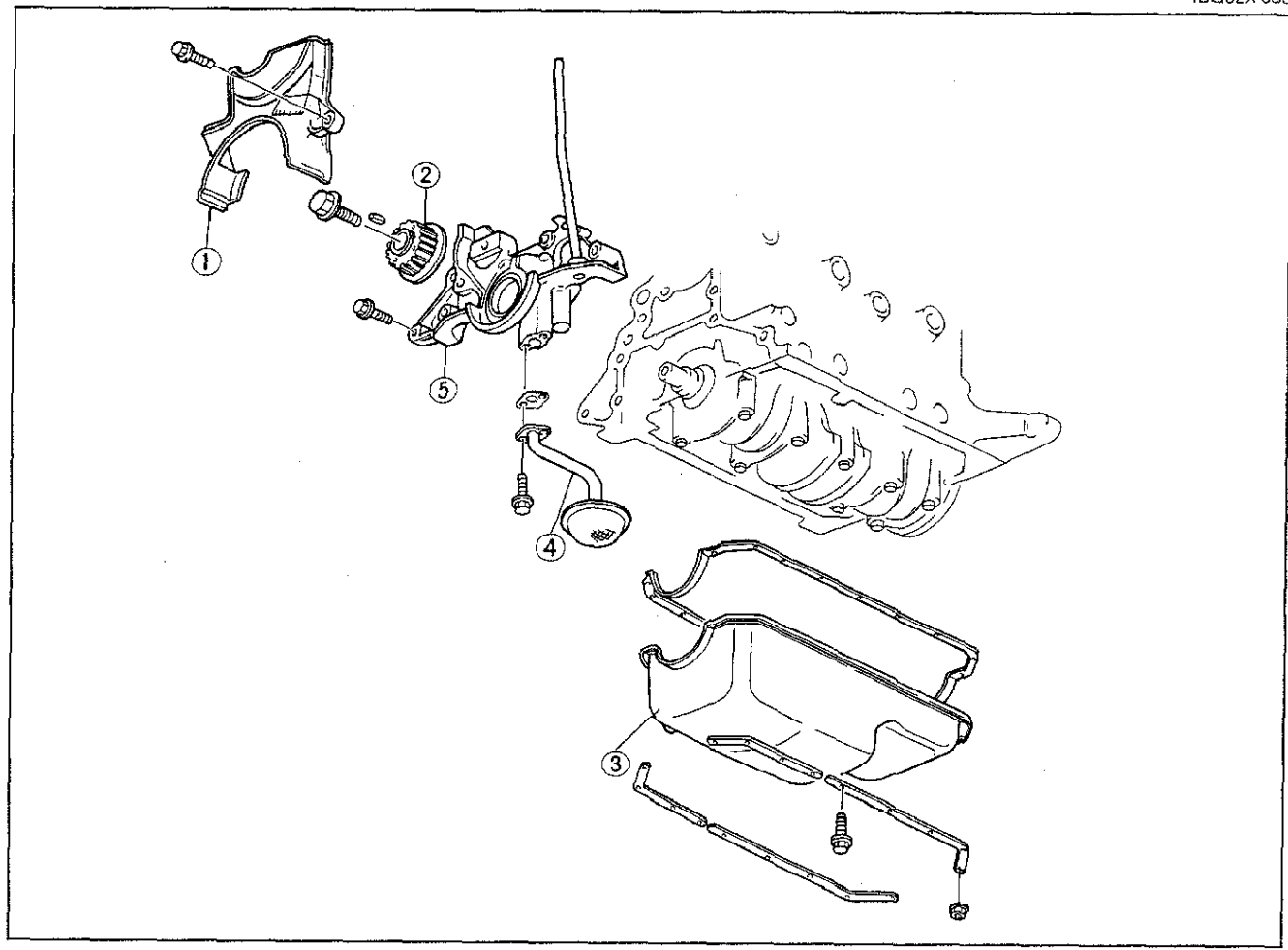

83U02A-008

1. Timing belt cover
2. Timing belt pulley
3. Oil pan (Refer to 2A—6)

4. Oil strainer
5. Oil pump

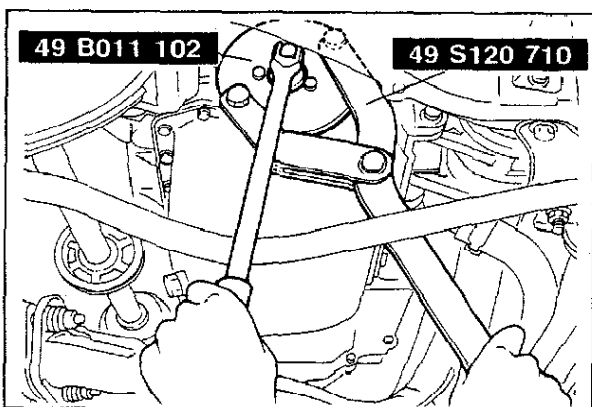

83U02X-010

### Timing Belt Pulley

1. Install the **SST** to the timing belt pulley.
2. Remove the lock bolt.
3. Remove the timing belt pulley.

## DISASSEMBLY AND ASSEMBLY

1. Disassemble the parts in the numbered sequence, shown in the figure.
2. Assemble in the reverse order of disassembly.

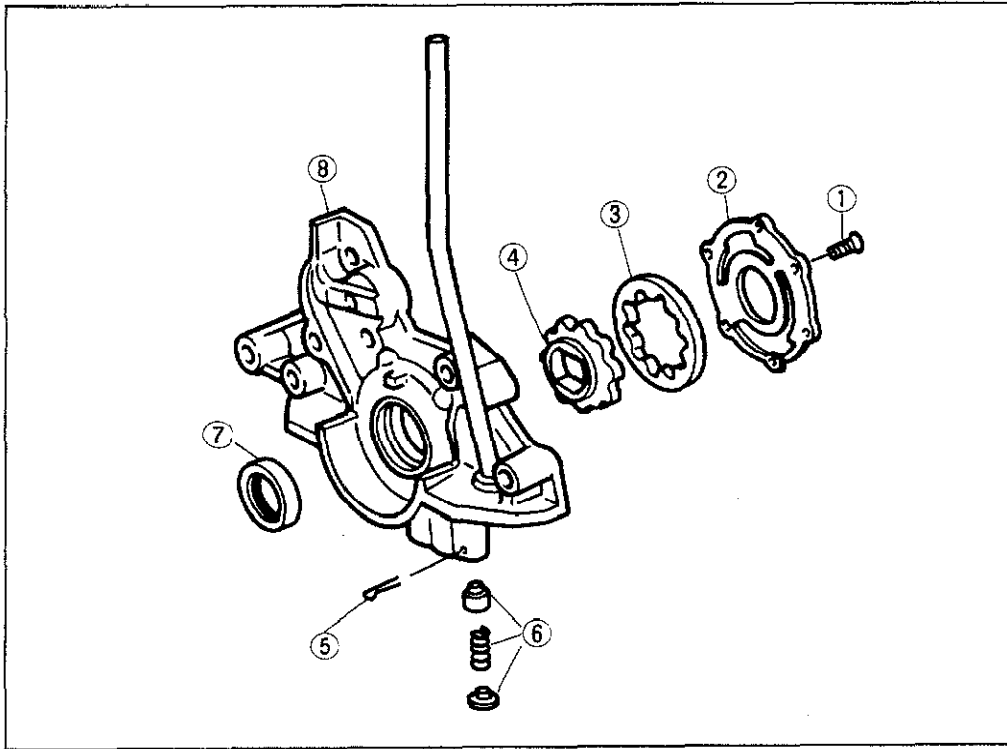

1. Bolt
2. Pump cover
3. Outer gear
4. Inner gear
5. Split pin
6. Plunger assembly
7. Oil seal
8. Pump body

83U02A-009

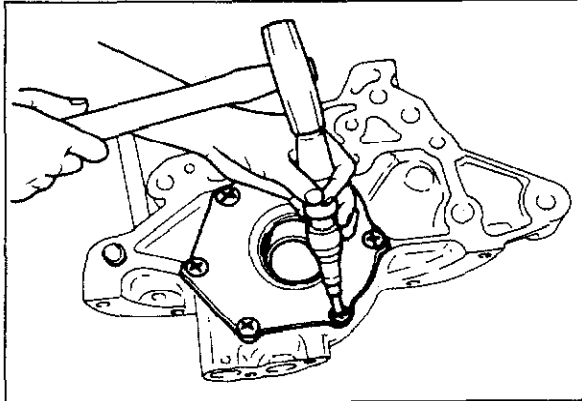

63U02X-016

### Oil Pump Cover Removal

Loosen the screws by an impact driver so that the oil pump body is not damaged.

### Installation

1. Coat locking agent on the screw threads.
2. Install the pump cover to the body.

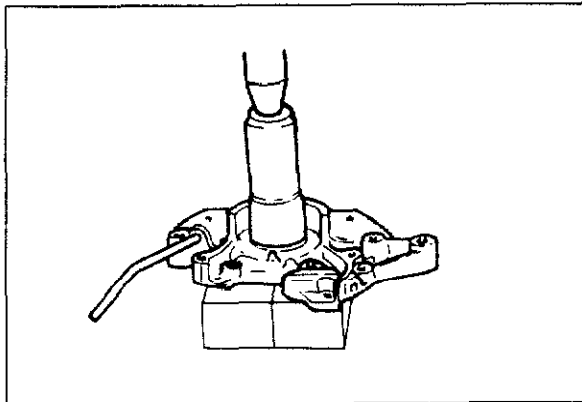

63U02X-017

### Oil Seal Removal

Remove the oil seal by using a screwdriver or similar tool to pry it out.

### Installation

1. Apply engine oil to the pump body and the new oil seal.
2. Press the oil seal in until it is flush with the front of the pump body.

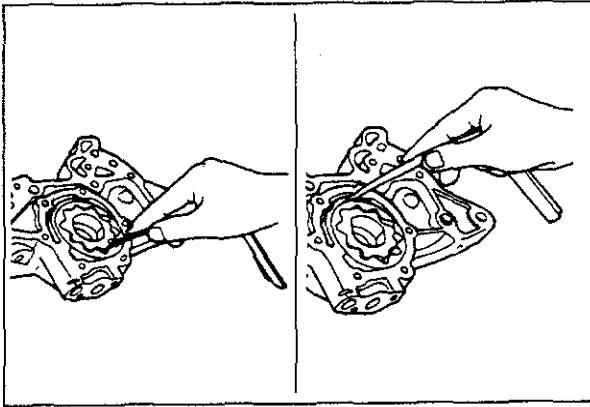

83U02X-011

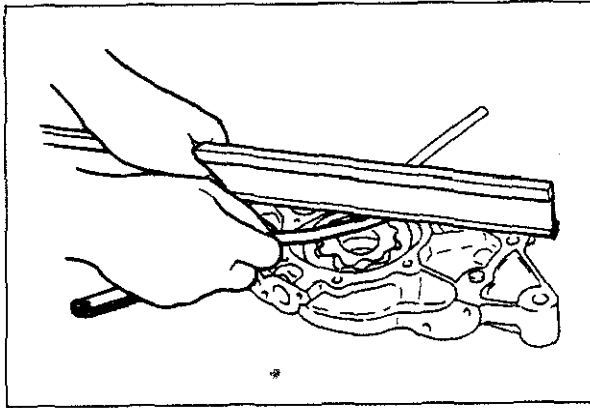

63U02X-019

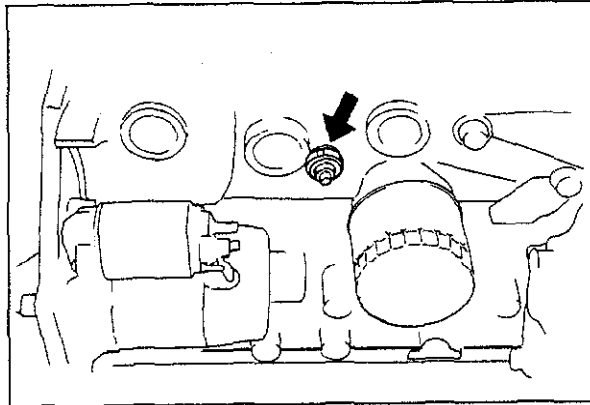

83U02X-012

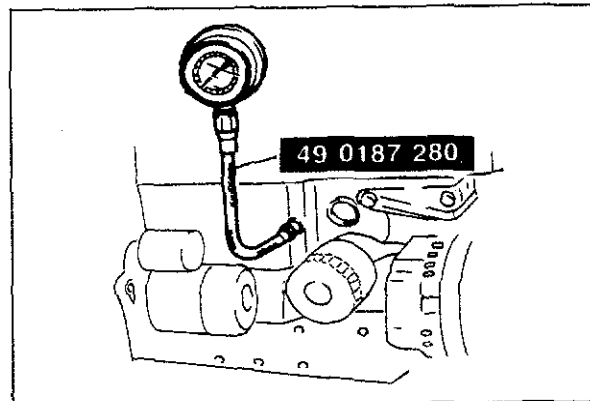

63U02X-021P

## INSPECTION

1. Inspect for distortion or damage to the pump body or cover.
2. Inspect for weak or damaged plunger.
3. Inspect for weak or broken plunger spring.
4. Measure the following clearances:

**Inner gear tooth tip and outer gear clearance:**  
0.2 mm (0.0079 in) max.

**Outer gear and pump body clearance:**  
0.22 mm (0.0087 in) max.

**Side clearance:**  
0.14 mm (0.0055 in) max.

5. Replace the gear assembly or oil pump body if the clearances are not within the limits.

## OIL PRESSURE

### INSPECTION

1. Remove the oil pressure switch.
2. Connect the **SST** to the pressure switch installation hole in the cylinder block.

3. Start the engine and let it warm up.
4. Maintain engine rpm at 3,000, and note the gauge reading.

**Standard oil pressure:**  
343—441kPa (3.5—4.5 kg/cm<sup>2</sup>, 50—64psi)

5. If the pressure is lower than specified, check and repair if necessary.  
(Refer to Troubleshooting Guide.)

# LUBRICATION SYSTEM (B6 DOHC)

- OUTLINE** ..... 2B- 2
  - STRUCTURAL VIEW..... 2B- 2
  - SPECIFICATIONS..... 2B- 3
- TROUBLESHOOTING GUIDE** ..... 2B- 3
- OIL FILTER**..... 2B- 4
  - REPLACEMENT ..... 2B- 4
- OIL COOLER** ..... 2B- 5
  - REMOVAL ..... 2B- 5
  - INSTALLATION ..... 2B- 5
- OIL PAN**..... 2B- 6
  - REMOVAL ..... 2B- 6
  - INSPECTION..... 2B- 7
  - INSTALLATION ..... 2B- 7
- OIL PUMP** ..... 2B- 9
  - REMOVAL AND INSTALLATION..... 2B- 9
  - DISASSEMBLY AND ASSEMBLY ..... 2B-10
  - INSPECTION..... 2B-11
- OIL PRESSURE**..... 2B-11
  - INSPECTION..... 2B-11
  - INSPECTION OF CYLINDER HEAD  
OIL PRESSURE ..... 2B-12

## OUTLINE

### STRUCTURAL VIEW

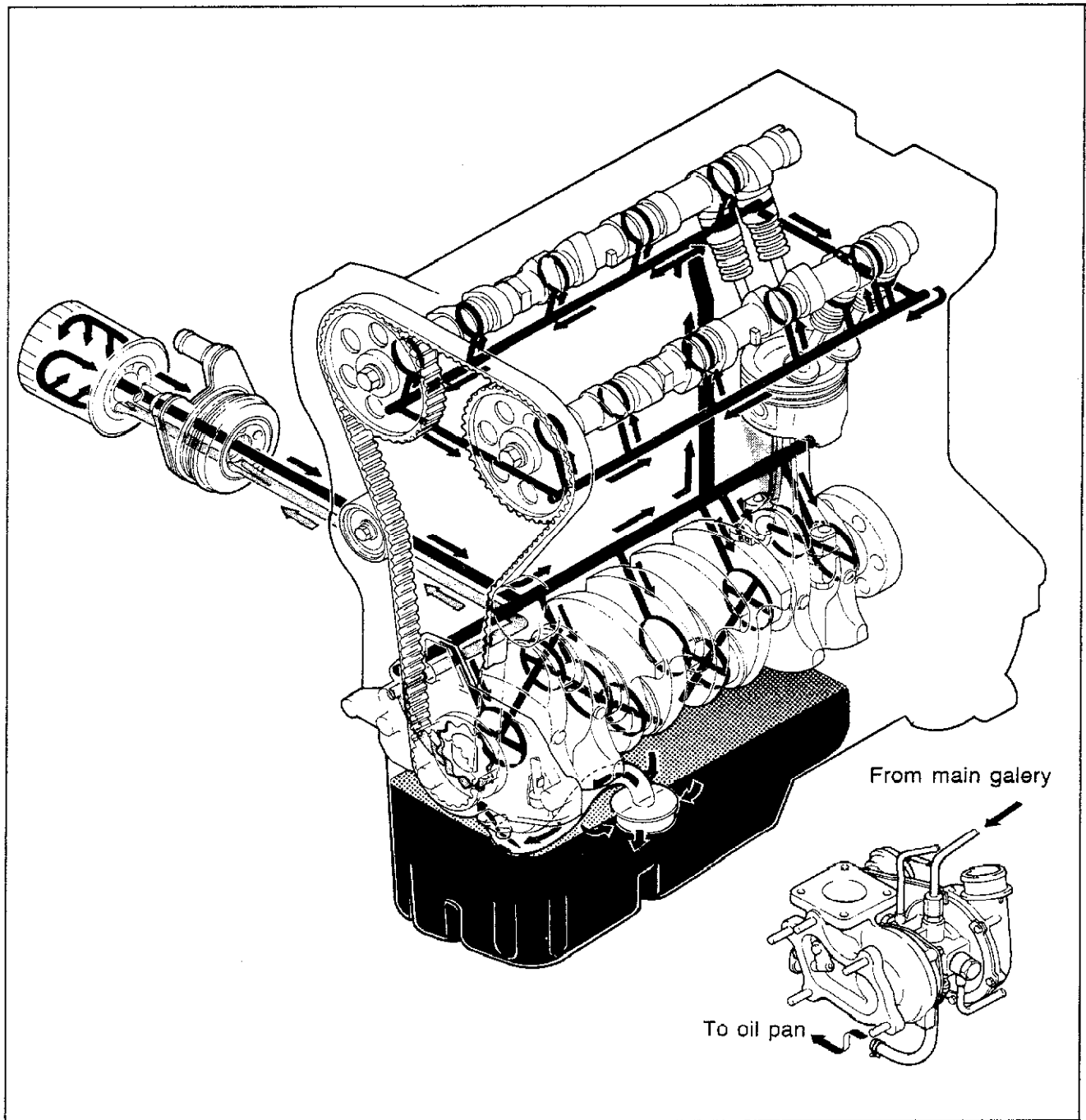

63G02C-302



## SPECIFICATIONS

Lubricating system		Force-fed type
Oil pump	Type	Trochoid gear type
	Oil pressure kPa (kg/cm <sup>2</sup> , psi)	343—441 (3.5—4.5, 50—64)
Oil filter	Type	Full-flow type, paper element
	Relief-valve opening pressure kPa (kg/cm <sup>2</sup> , psi)	98 (1.0, 14)
Oil warning pressure kPa (kg/cm <sup>2</sup> , psi)		29 (0.3, 4.3)
Oil capacity	Total liters (US qt, Imp qt)	3.6 (3.8, 3.2)
	Oil pan liters (US qt, Imp qt)	3.2 (3.4, 2.8)
	Oil filter liters (US qt, Imp qt)	0.3 (0.32, 0.26)
Engine oil		API service, SF

83U02B-002

## Recommended SAE viscosity numbers

Temperature (°C)	-30	-20	-10	0	10	20	30	40	50
	(°F)	-20	0	20	40	60	80	100	120
Engine oil	5W-30		30						
	5W-20		20W-20		40				
	10W-30								
	10W-40			10W-50					
	20W-40			20W-50					

76U02X-003

Temperature range anticipated before next oil change, °C(°F)

## TROUBLESHOOTING GUIDE

Problem	Possible Cause	Remedy	Page
<b>Oil leakage</b>	Loose drain plug	Tighten or replace	2B— 7
	Faulty seal at oil pan and cylinder block	Repair	2B— 7
	Damaged cylinder head cover	Refer to Section 1B	—
	Loose oil pump body bolt, cylinder head cover bolt, or oil pan bolt	Tighten	2B— 6
	Damaged front housing gasket, or cylinder head gasket	Refer to Section 1B	—
	Faulty oil seal(s)	Replace	—
	Loose oil filter	Tighten	2B— 4
Loose or damaged oil pressure switch	Tighten or replace	—	
<b>Oil pressure drop</b>	Oil leak	As described above	—
	Insufficient oil	Add oil	—
	Worn and/or damaged oil pump gear	Replace	2B—10
	Worn plunger (inside oil pump) or weak spring	Replace	2B—10
	Clogged oil strainer	Clean	2B— 9
Excessive lubrication clearance between main bearing or connecting rod bearing	Refer to Section 1B	—	
<b>Warning lamp illuminates while engine is running</b>	Oil pressure drop	As described above	—
	Malfunction of oil pressure switch	Refer to Section 15	—
	Problem in electrical system	Refer to Section 15	—

83U02B-003

## OIL FILTER

### REPLACEMENT

1. Remove the oil filter with an oil filter wrench.

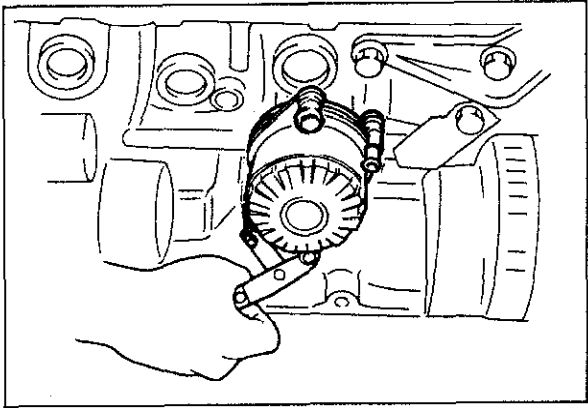

63U02X-006

2. Apply a small amount of engine oil to the O-ring of the new oil filter.

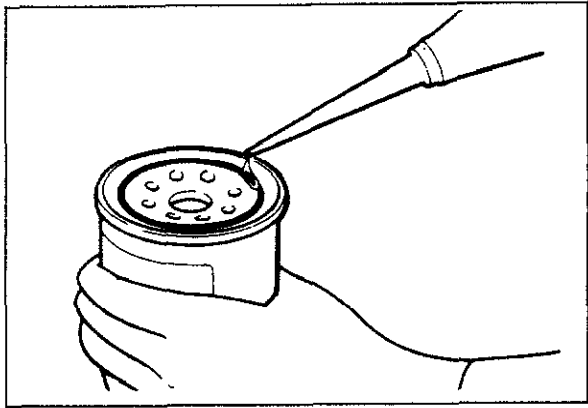

63U02X-007

3. Fully tighten the oil filter by hand.

4. Add engine oil to the correct level.

5. After installing the filter, check to be sure that there is no oil leakage while the engine is running.

6. Re-check the oil level using the dipstick.

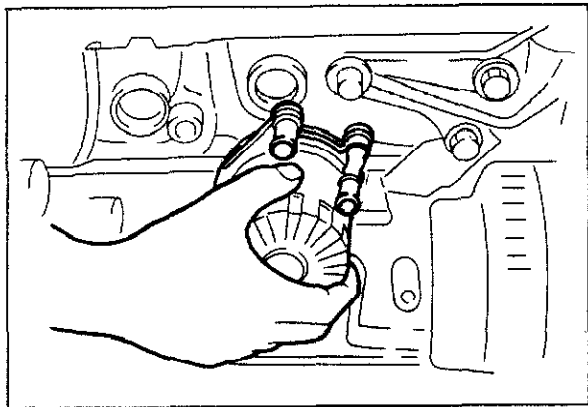

63U02X-008



83U02B-004

## OIL COOLER

### REMOVAL

1. Drain the engine oil.
2. Remove the under cover.
3. Remove the oil filter with an oil filter wrench.

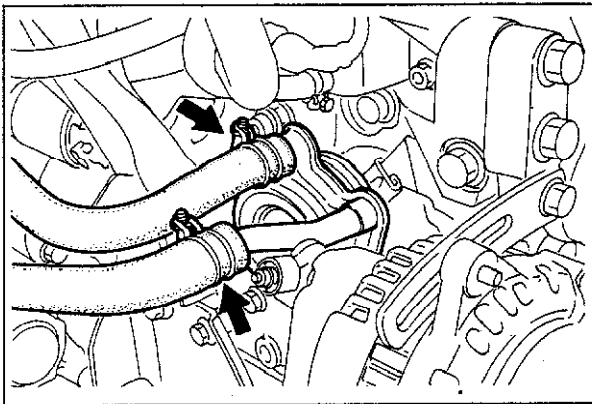

83U02B-005

4. Disconnect the water hoses.
5. Remove the oil cooler.

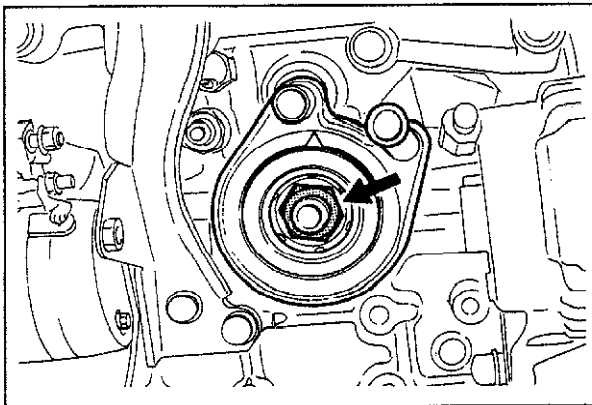

83U02B-006

### INSTALLATION

1. Install the oil cooler.

#### Tightening torque:

**29—39 N·m (3.0—4.0 m·kg, 22—29 ft·lb)**

2. Install the oil filter (Refer to page 2B—4).
3. Install the under cover.
4. Add engine oil to the correct level.

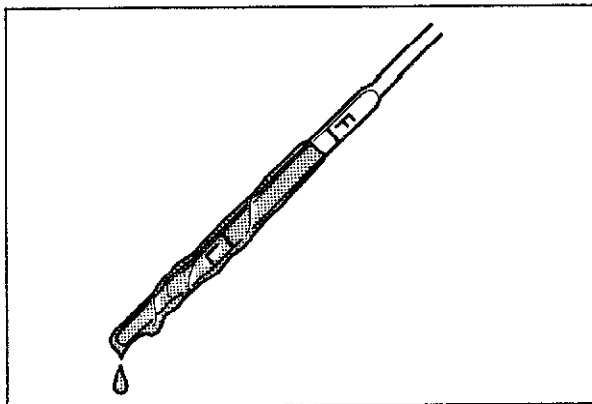

83U02B-007

5. After installing the filter, check that there is no oil leakage while the engine is running.
6. Re-check the oil level using the dipstick.

## OIL PAN

### REMOVAL

1. Disconnect the battery negative cable.
2. Drain the engine oil.
3. Mount the engine support (49 B017 5A0) and suspend the engine.
4. Remove the the parts in the numbered sequence shown in the figure.

1. Engine under covers
2. Exhaust pipe bracket
3. Exhaust pipe
4. Turbocharger bracket
5. Oil pan
6. Gasket

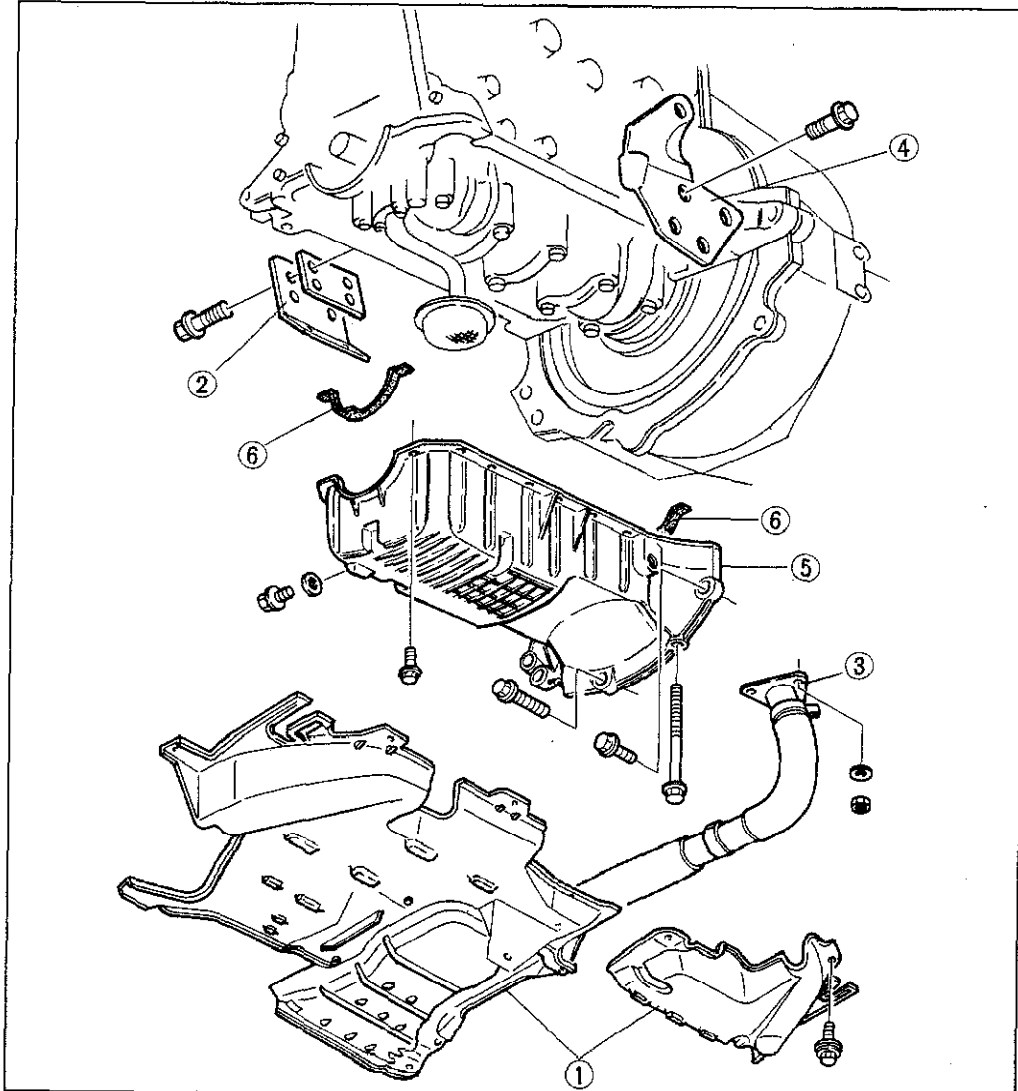

83U02B-008

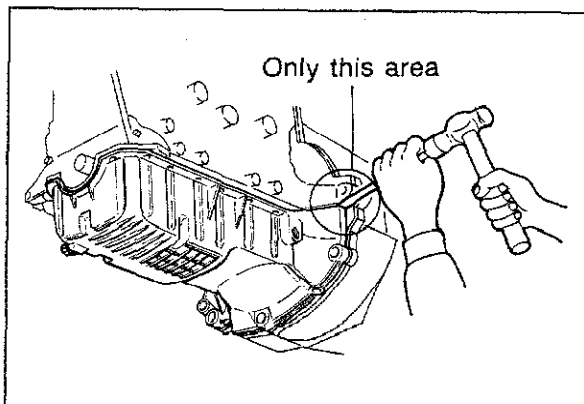

73G01C-008

### Removal Note

1. Remove the oil pan by prying only at the points shown in the figure.
2. Loosen the mounting member bolts until the oil pan can be removed.

### Caution

- a) Do not force a pry tool between the block and pan to prevent damaging the contact surfaces.
- b) Do not damage or scratch the contact surface when removing the old sealant.

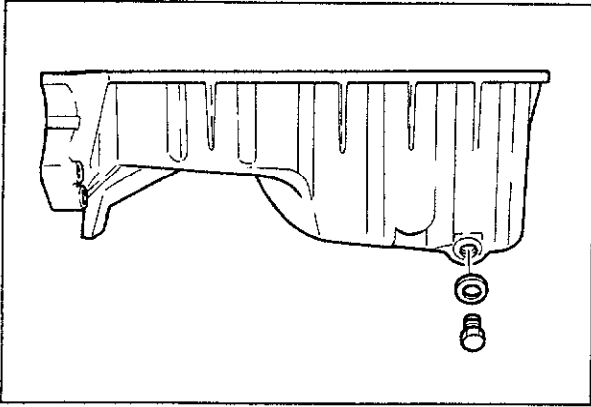

63U02X-013

## INSPECTION

Check the following points. Repair or replace, if necessary.

1. Cracks, deformation, damage (at bolt locations).
2. Damaged drain plug threads.

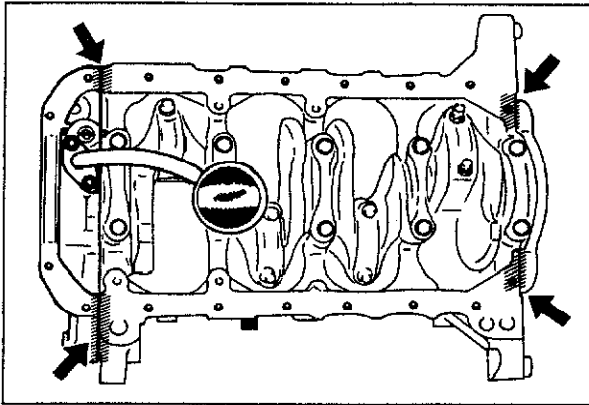

83U02B-009

## INSTALLATION

Install in the reverse order of removal.

### Installation Note

1. Apply sealant to the places indicated by the arrows in the figure after cleaning the cylinder block surface.

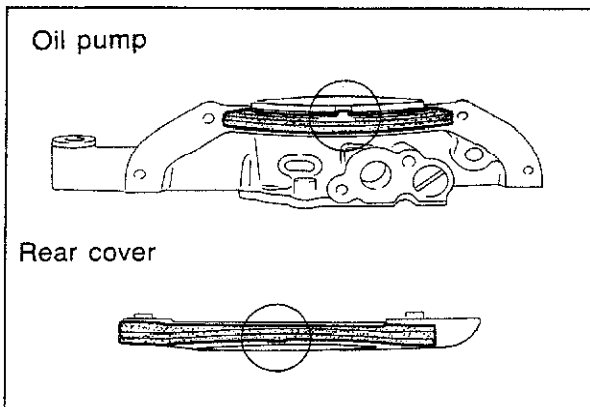

73G01C-011

2. Install the gaskets onto the oil pump body and rear cover with the projections in the notches as shown.

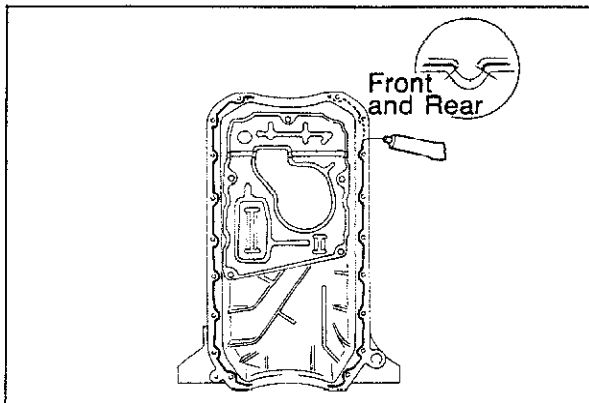

73G01C-012

3. Clean the oil pan contact surface.

### Caution

**Do not leave any dirt or oil on it.**

4. Apply silicone sealant to the oil pan continuously with the bead of **2.5—3.5 mm (0.0984—0.1378 in)**, rimming the surface inside the bolt holes as shown.

### Caution

**After the sealant is applied, the pan must be secured within 30 minutes.**

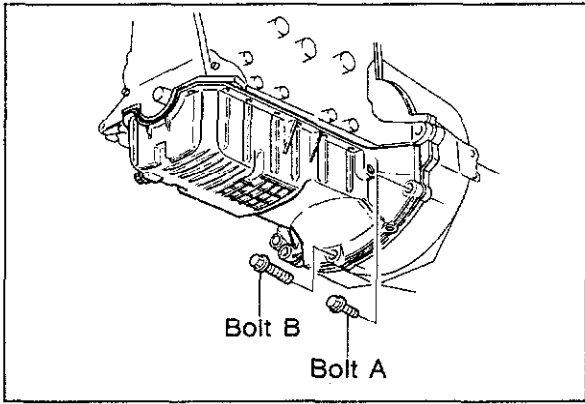

83U02B-010

5. Install the oil pan and tighten the transaxle connecting bolts.

**Tightening torque:**

**Bolt A: 37—52 N·m  
(3.8—5.3 m·kg, 27—38 ft·lb)**

**Bolt B: 19—26 N·m  
(1.9—2.6 m·kg, 14—19 ft·lb)**

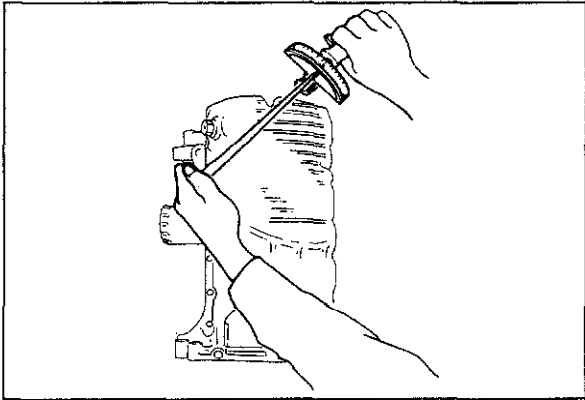

83U02B-011

6. Tighten the bolts gradually in three steps.

**Tightening torque:**

**8—11 N·m (0.8—1.1 m·kg, 69—95 in·lb)**

**Steps After Installation**

1. Add the prescribed amount of oil.
2. Check for oil leakage after starting the engine.

83U02B-012

## OIL PUMP

### REMOVAL AND INSTALLATION

1. Disconnect the battery negative cable.
2. Drain the engine oil.
3. Remove each part in the numbered sequence shown in the figure.
4. Install in the reverse order of removal.

4BG02X-038

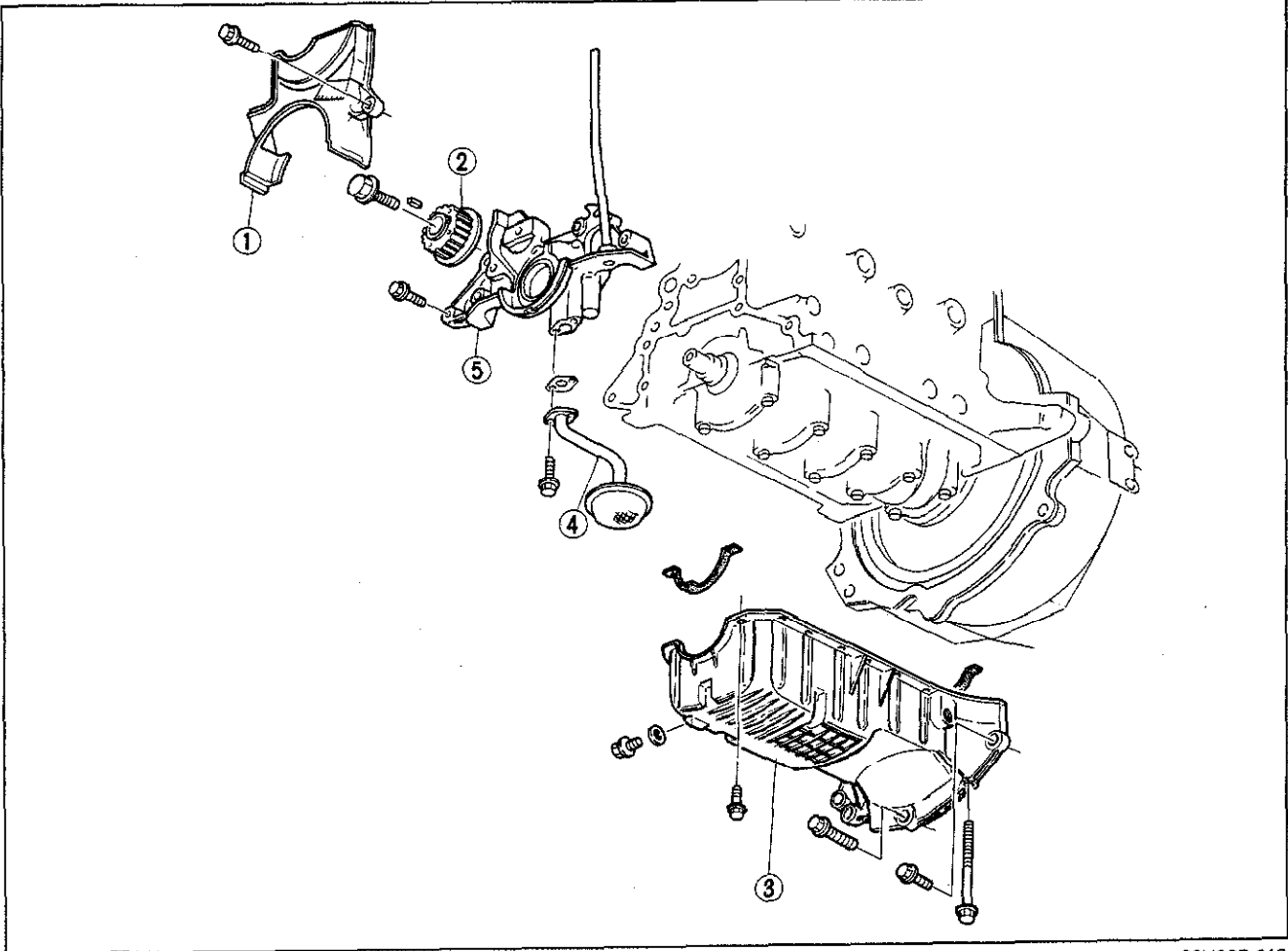

83U02B-013

1. Timing belt cover
2. Timing belt pulley
3. Oil pan (Refer to page 2B—6)

4. Oil strainer
5. Oil pump

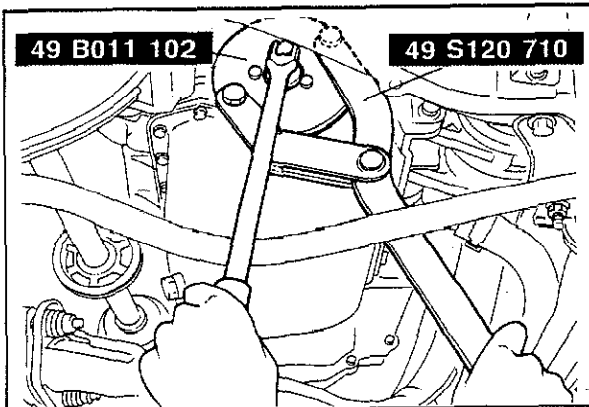

83U02A-010

### Timing Belt Pulley

1. Install the **SST** to the timing belt pulley.
2. Remove the lock bolt.
3. Remove the timing belt pulley.

# 2B OIL PUMP

## DISASSEMBLY AND ASSEMBLY

1. Disassemble the parts in the numbered sequence, shown in the figure.
2. Assemble in the reverse order of disassembly.

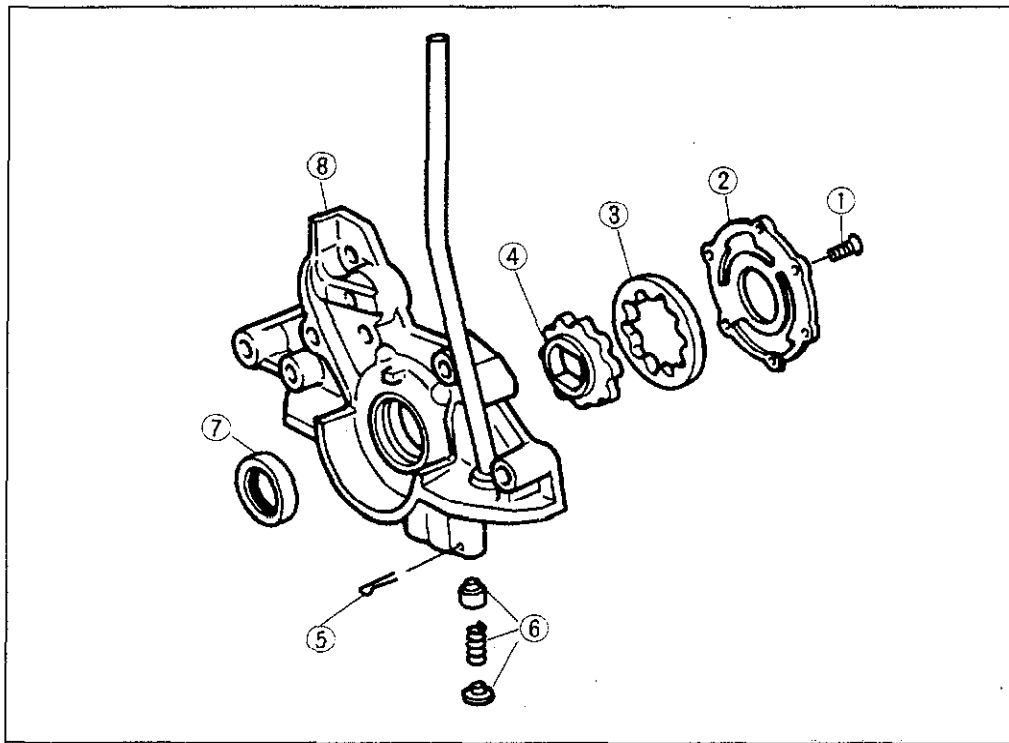

1. Bolt
2. Pump cover
3. Outer gear
4. Inner gear
5. Split pin
6. Plunger assembly
7. Oil seal
8. Pump body

83U02A-009

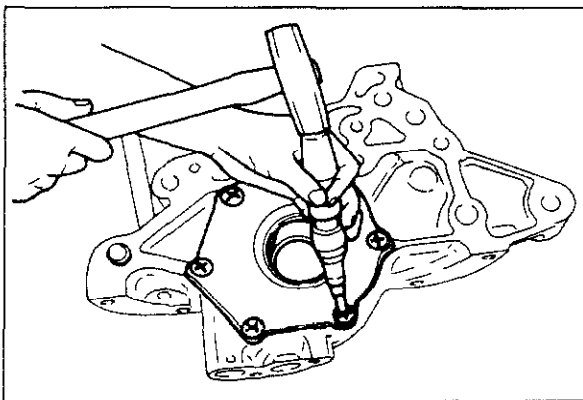

63U02X-016

### Oil Pump Cover Removal

Loosen the screws by an impact driver so that the oil pump body is not damaged.

### Installation

1. Coat locking agent on the screw threads.
2. Install the pump cover to the body.

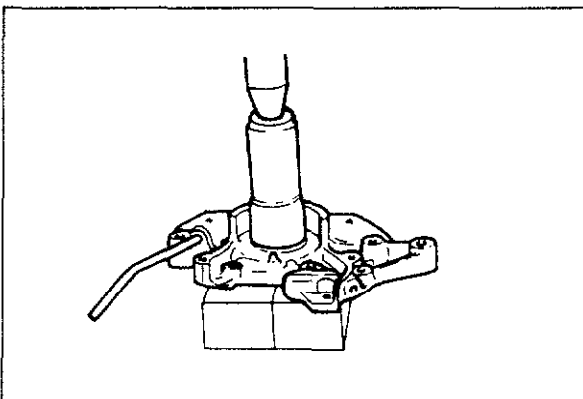

63U02X-017

### Oil Seal Removal

Remove the oil seal by using a screwdriver or similar tool to pry it out.

### Installation

1. Apply engine oil to the pump body and the new oil seal.
2. Press the oil seal in until it is flush with the front of the pump body.



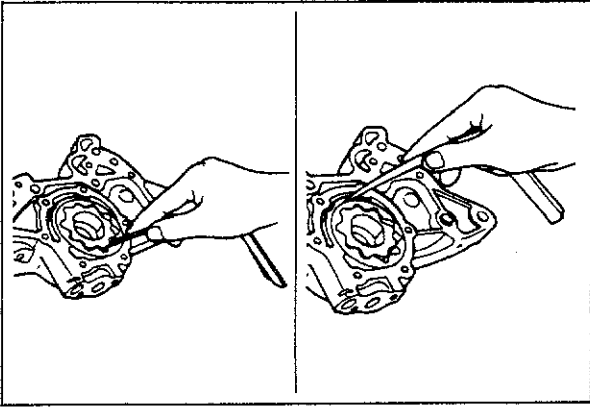

83U02A-011

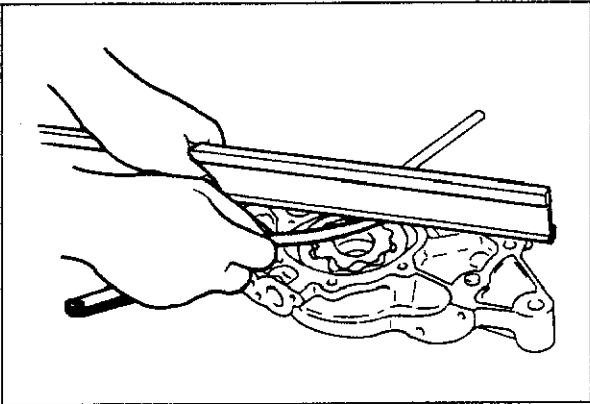

63U02X-019

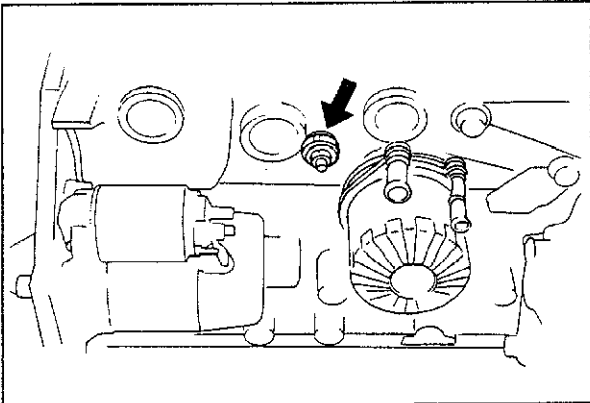

83U02A-012

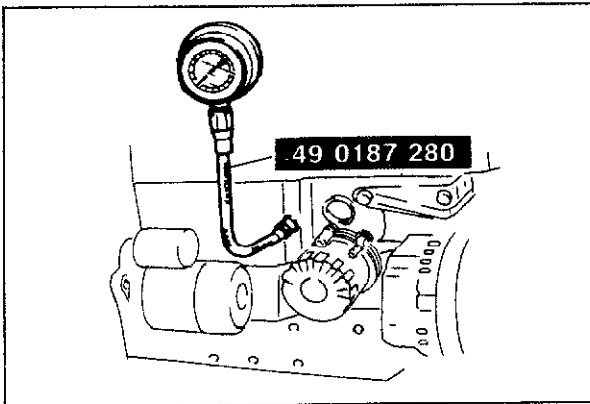

63U02X-021F

## INSPECTION

1. Inspect for distortion or damage to the pump body or cover.
2. Inspect for weak or damaged plunger.
3. Inspect for weak or broken plunger spring.
4. Measure the following clearances:

**Inner gear tooth tip and outer gear clearance:**  
0.2 mm (0.0079 in) max.

**Outer gear and pump body clearance:**  
0.22 mm (0.0087 in) max.

**Side clearance**  
0.14 mm (0.0055 in) max.

5. Replace the gear assembly or oil pump body if the clearances are not within the limits.

## OIL PRESSURE

### INSPECTION

1. Remove the oil pressure switch.
2. Connect the **SST** to the pressure switch installation hole in the cylinder block.

3. Start the engine and let it warm up.
4. Maintain engine rpm at 3,000, and note the gauge reading.

**Standard oil pressure:**  
343—441kPa (3.5—4.5 kg/cm<sup>2</sup>, 50—64psi)

5. If the pressure is lower than specified, check and repair if necessary.  
(Refer to Troubleshooting Guide.)

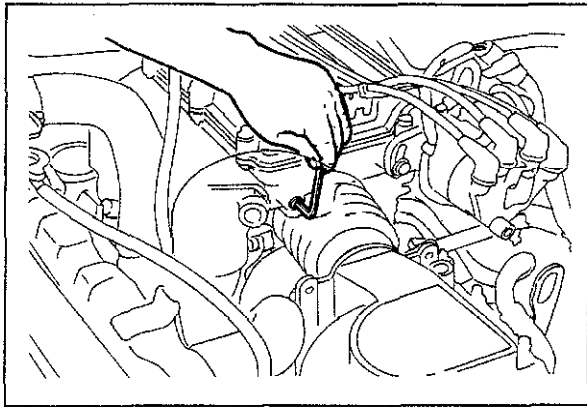

83U02B-014

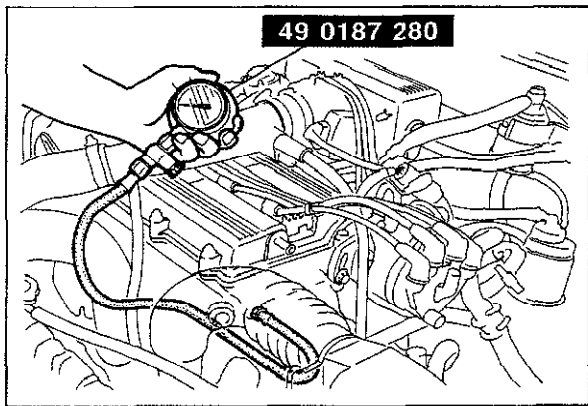

49 0187 280

63G02C-304

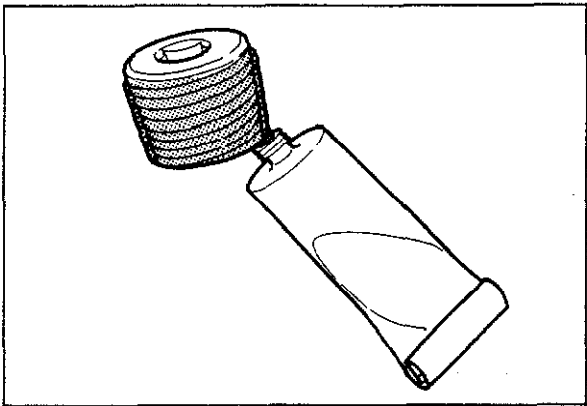

83U02B-015

## INSPECTION OF CYLINDER HEAD OIL PRESSURE

1. Remove the blind plug on the cylinder head oil gallery using a hexagon wrench.
2. Connect the **SST** to the oil gallery.

3. Start the engine and let it warm up to normal operating temperature.
4. Maintain the engine speed at 3,000 rpm and note the gauge reading.

### Standard oil pressure

98—196 kPa

(1.0—2.0 kg/cm<sup>2</sup>, 14—28 psi) —3,000 rpm

5. If oil pressure is lower than specifications, check and repair as necessary.

6. After checking the oil pressure, apply sealant to the blind plug.

### Caution

**If reinstalling the blind plug, clean the threads to remove old sealant, apply new sealant and tighten to specification.**

**If old sealant cannot be removed, replace the blind plug.**

### Tightening torque

12—18 N·m

(1.2—1.8 m·kg, 108—154 in·lb)

# COOLING SYSTEM (B6 EGI)

<b>OUTLINE</b> .....	3A— 2
STRUCTURAL VIEW.....	3A— 2
SPECIFICATIONS.....	3A— 3
<b>TROUBLESHOOTING GUIDE</b> .....	3A— 3
<b>COOLANT</b> .....	3A— 4
INSPECTION.....	3A— 4
REPLACEMENT.....	3A— 4
<b>RADIATOR CAP</b> .....	3A— 5
INSPECTION.....	3A— 5
<b>ELECTRIC FAN MOTOR</b> .....	3A— 5
INSPECTION.....	3A— 5
<b>WATER THERMO SWITCH</b> .....	3A— 6
INSPECTION.....	3A— 6
<b>ELECTRIC FAN RELAY</b> .....	3A— 6
INSPECTION.....	3A— 6
<b>WATER PUMP DRIVE BELT</b> .....	3A— 6
INSPECTION AND ADJUSTMENT.....	3A— 6
<b>THERMOSTAT</b> .....	3A— 7
REMOVAL AND INSTALLATION.....	3A— 7
INSPECTION.....	3A— 7
<b>RADIATOR</b> .....	3A— 8
REMOVAL AND INSTALLATION.....	3A— 8
INSPECTION.....	3A— 8
<b>WATER PUMP</b> .....	3A— 9
REMOVAL AND INSTALLATION.....	3A— 9

## OUTLINE

### STRUCTURAL VIEW

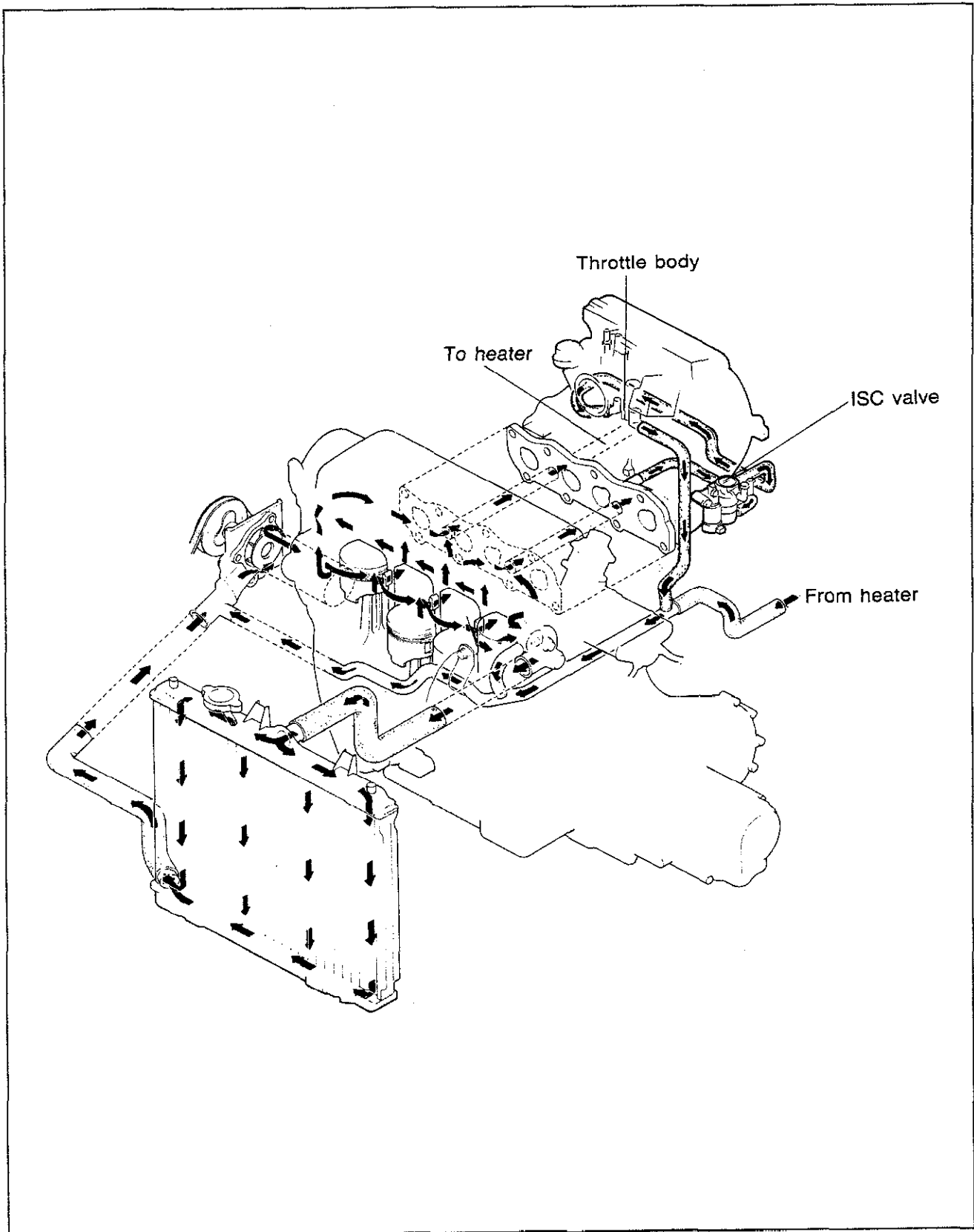

63U03X-002

## SPECIFICATIONS

Cooling system		Water-cooled, forced circulation	
Coolant capacity	With heater    liters (US qt, Imp qt.)	MTX 5.0 (5.3, 4.4)	ATX 6.0 (6.3, 5.3)
Thermostat	Type	2 stage	
	Opening temperature    °C (°F)	SUB. 85 (185)	MAIN. 88 (190)
	Full-open temperature    °C (°F)	100 (212)	
	Full-open lift    mm (in)	SUB. 1.5 (0.06) or more	MAIN. 8 (0.31) or more
Water pump	Type	Centrifugal	
Radiator	Type	Corrugated fin type	
	Cap valve pressure    kPa (kg/cm <sup>2</sup> , psi)	74—103 (0.75—1.05, 11—15)	
Cooling fan	Outer diameter    mm (in)	MTX: 300 (11.8), ATX: 320 (12.6)	
	No. of blades	4	

83U03A-002

## TROUBLESHOOTING GUIDE

Problem	Possible Cause	Remedy	Page
<b>Coolant leakage</b>	Damaged radiator core seam	Replace	3A— 8
	Leakage from radiator hose or heater hose	Repair or replace	3A— 8
	Leakage from water thermo switch	Repair or replace	3A— 6
	Malfunction of water pump seal	Replace	3A— 9
	Damaged or loose thermostat cover or gasket	Repair or replace	3A— 7
	Loose cylinder head bolt	Refer to Section 1A	—
	Damaged cylinder head gasket	Refer to Section 1A	—
	Cracked cylinder block Cracked cylinder head	Refer to Section 1A Refer to Section 1A	— —
<b>Corrosion</b>	Impurities in coolant	Clean and flush	3A— 4
<b>Overheating</b>	Water passage clogged	Clean	3A— 8
	Thermostat malfunction	Replace	3A— 7
	Radiator fins clogged	Clean	3A— 8
	Water pump malfunction	Repair or replace	3A— 9
	Insufficient coolant	Add	3A— 4
	Electric fan motor malfunction	Replace	3A— 5
	Electric fan relay malfunction	Replace	3A— 6
	Radiator cap malfunction	Replace	3A— 5

83U03A-003

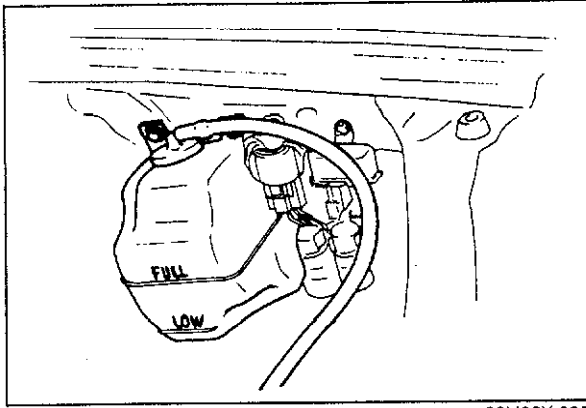

63U03X-005

## COOLANT

### INSPECTION

#### Coolant level

While the coolant is cold, the coolant level should be near the radiator inlet port, and the level in the reserve tank should be between the FULL and LOW marks. Add coolant if the level is low.

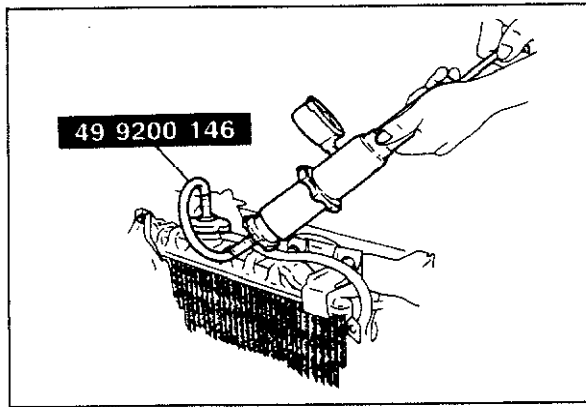

83U03X-014

#### Coolant leakage

1. Connect the tester with **SST** to the radiator inlet port.
2. Apply a pressure of **103 kPa (1.05 kg/cm<sup>2</sup>, 15 psi)** to the tester.
3. Note if the tester indicator shows a reduction of pressure. If it does, there may be a coolant leak. Check for leaks.

#### Warning

**When removing either the radiator cap or the tester with adapter, loosen it slowly until the pressure in the radiator is released, and then remove it.**

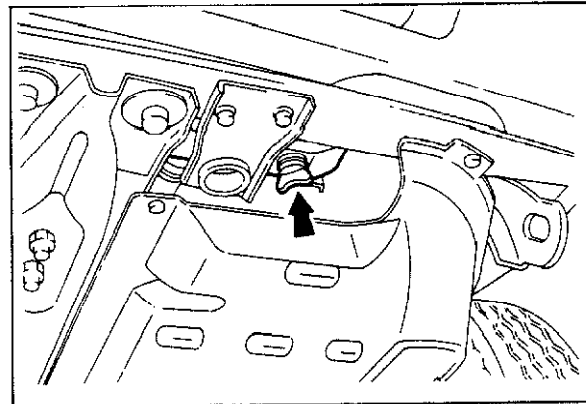

63U03X-007

### REPLACEMENT

1. Drain the coolant by opening the radiator drain plug.
2. Close the plug tightly.
3. After pouring anti-freeze into the radiator in accordance with the table below, add soft water.
4. Start engine, bleed the air from the coolant passages, and then add coolant as necessary.

#### Anti-freeze solution mixture percentage

Protection	Mixture percentage (by volume)	
	Anti-freeze solution	Water
Above -16°C (3°F)	35	65
Above -26°C (-15°F)	45	55
Above -40°C (-40°F)	55	45

83U03A-004

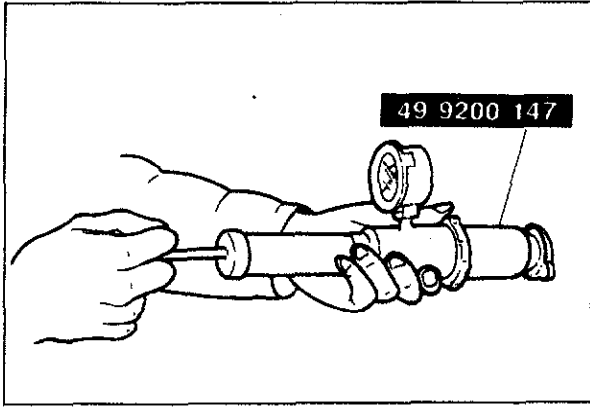

83U03X-015

## RADIATOR CAP

### INSPECTION

#### Radiator Cap Valve

1. Remove foreign material (water residue, etc.) from between the radiator cap valve and the valve seat.
2. Attach the radiator cap with **SST** to a tester. Apply pressure gradually to **74—103 kPa (0.75—1.05 kg/cm<sup>2</sup>, 11—15 psi)**.
3. Wait about 10 seconds, and check whether the pressure has decreased.  
The cap is normal if the pressure is maintained for about 10 seconds.

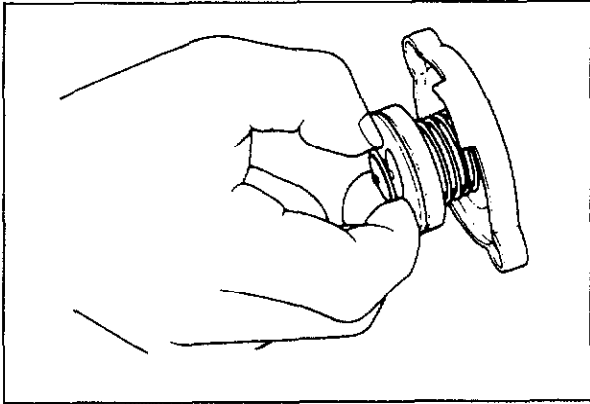

63U03X-009

#### Negative-Pressure Valve

1. Pull the negative-pressure valve to open it. Check that it closes completely when released.
2. Check for damage on the contact surfaces, cracked or deformed seal packing. Replace the radiator cap if necessary.

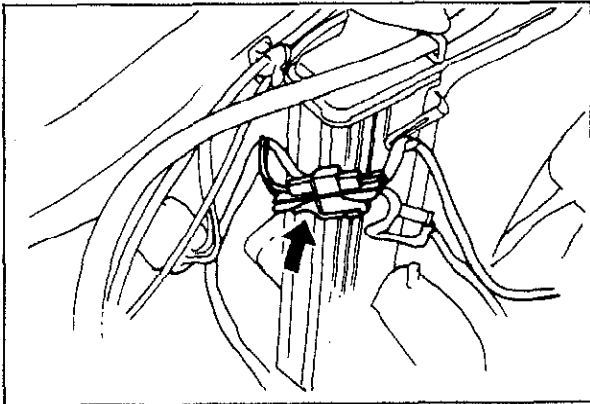

63U03X-010

## ELECTRIC FAN MOTOR

### INSPECTION

1. Disconnect the fan motor connectors.

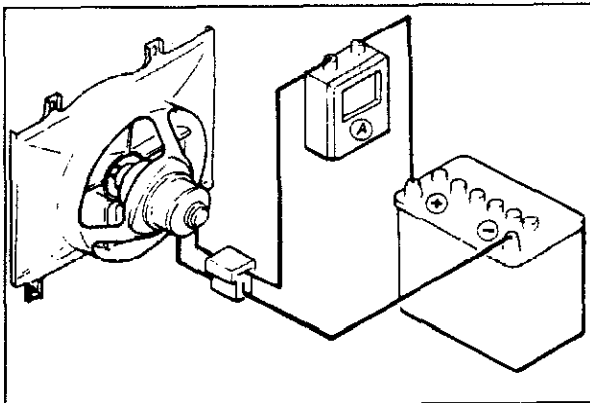

83U03A-006

2. Connect an ammeter and battery to the fan motor connectors.
3. Check to be sure that the fan motor operates smoothly at the standard current or less.

**Standard current: 5.6—7.6 Amperes (MTX)  
10.0—11.0 Amperes (ATX)**

4. If the fan motor is faulty, replace it.

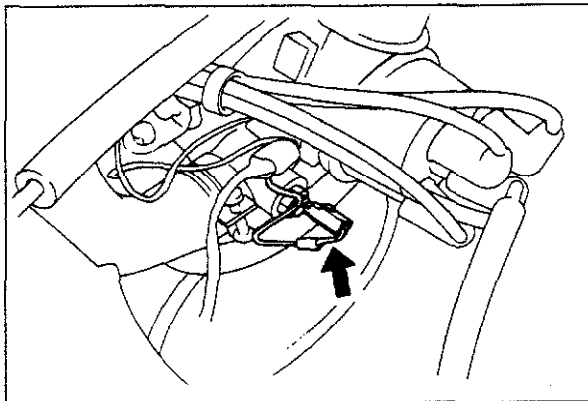

63U03X-012

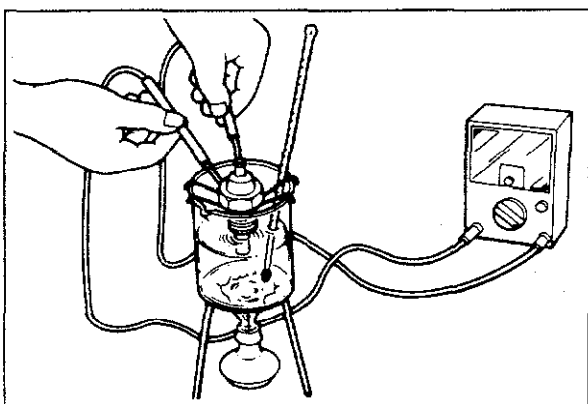

83U03A-007

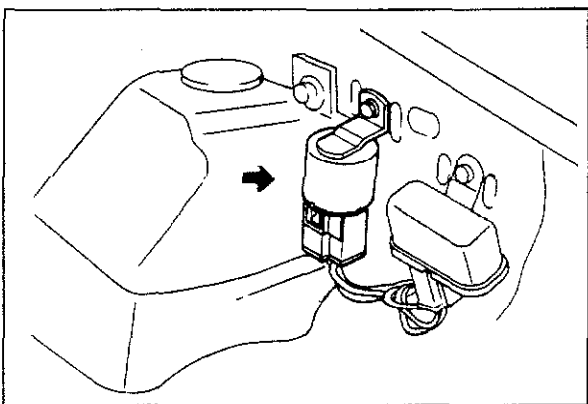

63U003X-014

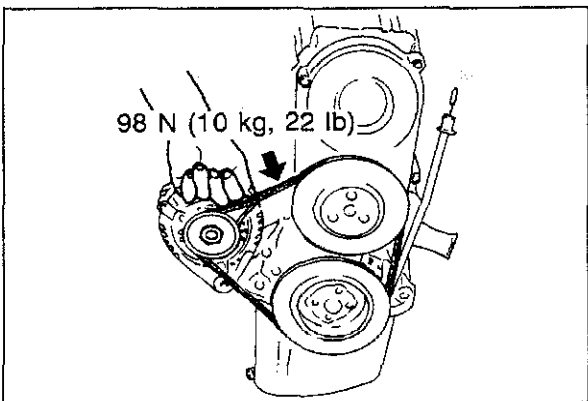

63U03X-015

## WATER THERMO SWITCH

### INSPECTION

1. Remove the electric fan water thermo switch.

#### Caution

**Do not disconnect the water thermo switch connector while the ignition switch is ON because the fan will turn.**

2. Place the water thermo switch in a container of water.
3. Connect a circuit tester to the water thermo switch.
4. Check that continuity is not indicated when the water temperature is **97°C (207°F)** or higher, and that continuity is indicated when the temperature is **90°C (194°F)** or less.
5. If the water thermo switch is faulty, replace it.

#### Notes

**a) Use a new O-ring when installing the water thermo-switch. Do not use seal tape on the threads of the thermo switch.**

**b) Check for water leakage after installation.**

## ELECTRIC FAN RELAY

### INSPECTION

1. Disconnect the water thermo switch connector, and then check whether the fan turns when the ignition switch is turned ON. If it does, the relay is functioning properly.
2. If the fan doesn't turn on, check for a malfunction of the fan relay, check the fuse and wiring harness, and check for poor contact or a loose coupler.

## WATER PUMP DRIVE BELT

### INSPECTION AND ADJUSTMENT

1. Check all surfaces of the V-belt. Replace it if it is cracked or damaged.
2. Check the amount of deflection (at point half-way between the water pump pulley and the alternator pulley) by applying a pressure of about **98N (10 kg, 22 lb)**.

#### Deflection

**New: 8—9 mm (0.31—0.35 in)**

**Used: 9—10 mm (0.35—0.39 in)**



**THERMOSTAT****REMOVAL AND INSTALLATION**

1. Drain the coolant.
2. Remove the parts in the numbered sequence shown in the figure.
3. Install in the reverse order of removal.

83U03A-008

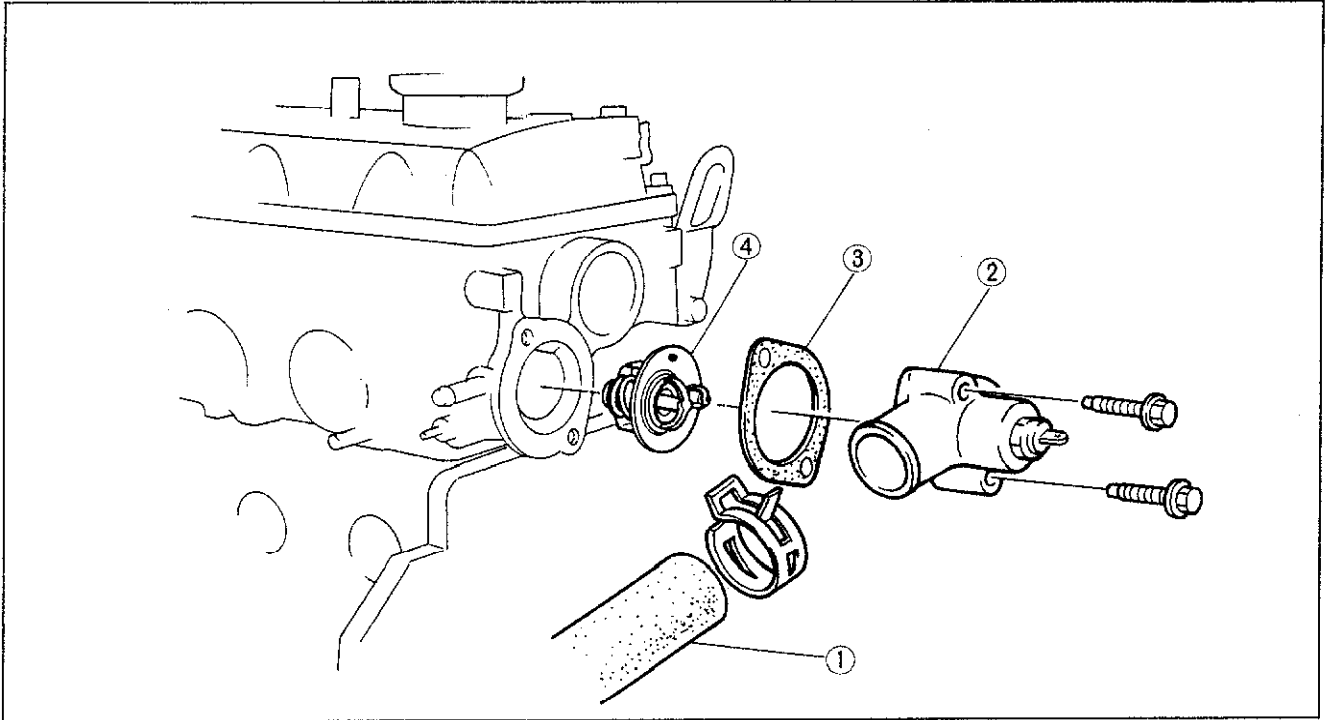

83U03A-009

1. Water hose
2. Thermostat cover
3. Gasket
4. 2 stage thermostat

**Note**

- a) The jiggle pin should be on the upper side.
- b) Position the hose clamp in the original location on the hose and squeeze it lightly with large pliers to ensure a good fit.

**INSPECTION**

Check the operation. Replace if necessary.

1. Visually check the valve to be sure it is air tight.
2. Place the thermostat and a thermometer in water, gradually increase the water temperature, and then check the following:
  - (1) Valve opening temperature
    - Sub-valve **83.5—86.5°C (182—188°F)**
    - Main valve **86.5—89.5°C (188—193°F)**
  - (2) Full open lift
    - Sub-valve **1.5 mm (0.06 in)** or more at **100°C (212°F)**
    - Main valve **8 mm (0.31 in)** or more at **100°C (212°F)**
  - (3) Valve closing temperature
    - Sub-valve **80°C (176°F)**
    - Main valve **83°C (181°F)**

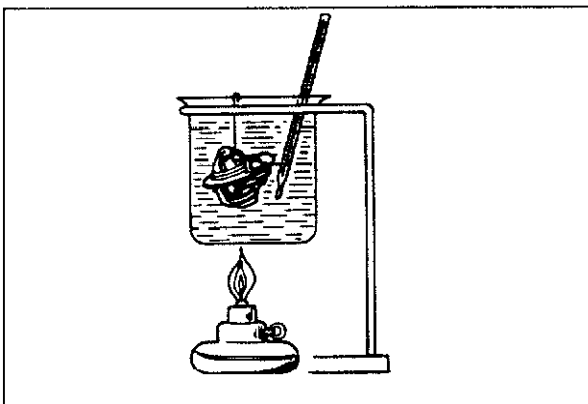

63U03X-017

## RADIATOR

### REMOVAL AND INSTALLATION

1. Drain the coolant.
2. Remove the parts in the numbered sequence shown in the figure.
3. Install in the reverse order of removal.

83U03A-010

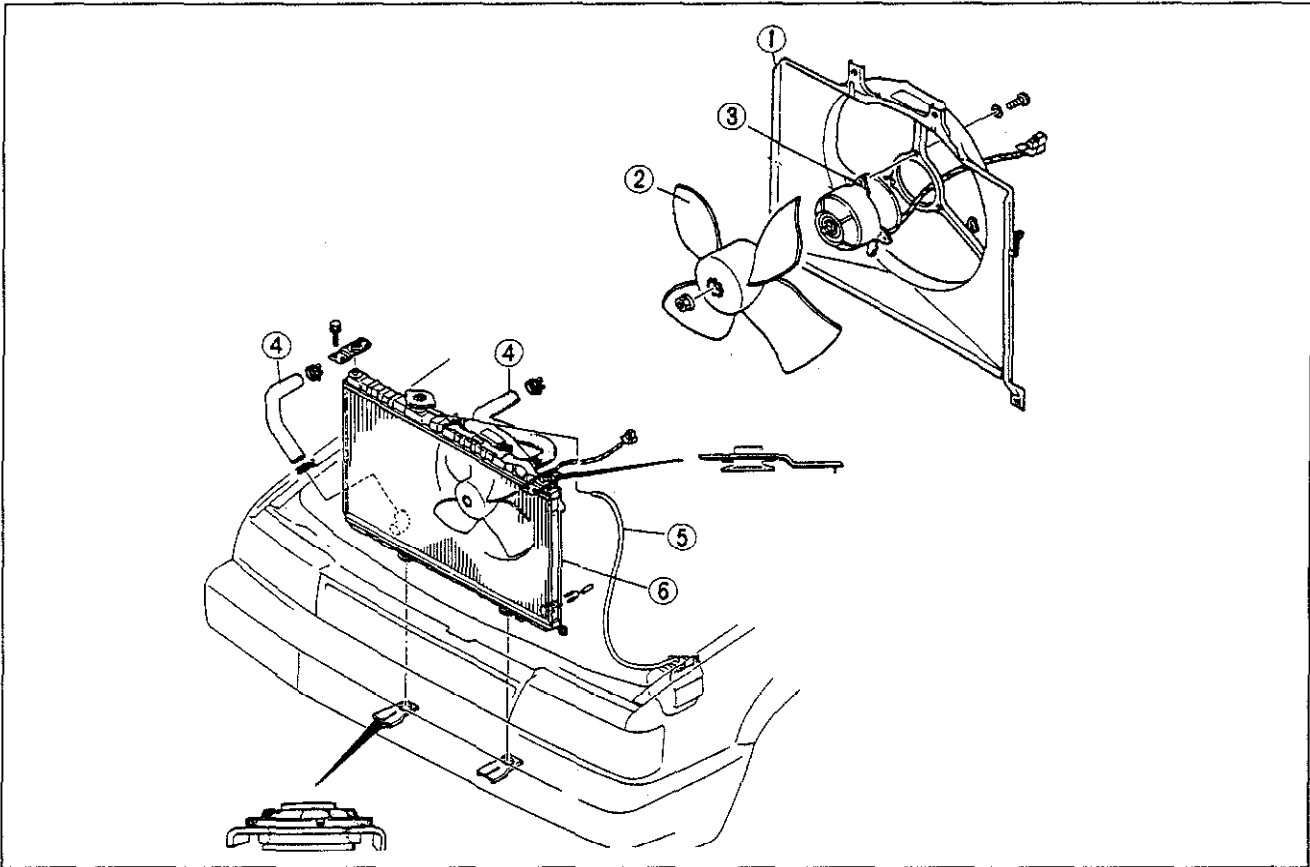

83U03A-011

- |                      |                      |
|----------------------|----------------------|
| 1. Radiator cowl     | 4. Radiator hose     |
| 2. Cooling fan       | 5. Reserve tank hose |
| 3. Cooling fan motor | 6. Radiator          |

#### Note

Position the hose clamp in the original location on the hose and squeeze it lightly with large pliers to ensure a good fit.

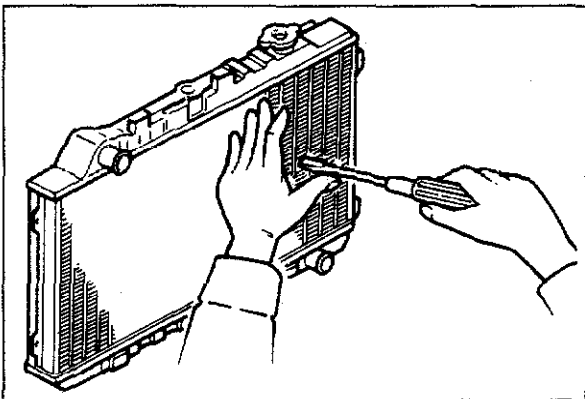

63U03X-019

#### INSPECTION

Check the following points; repair or replace if necessary:

1. Cracks; damage, or water leakage
2. Bent fins (repair by using a screwdriver)
3. Distorted or damaged radiator inlet.

## WATER PUMP

### REMOVAL AND INSTALLATION

1. Turn the crankshaft so that the No. 1 cylinder is at top dead center of compression.
2. Drain the coolant.
3. Remove the parts in the numbered sequence shown in the figure.
4. Install in the reverse order of removal.

83U03A-012

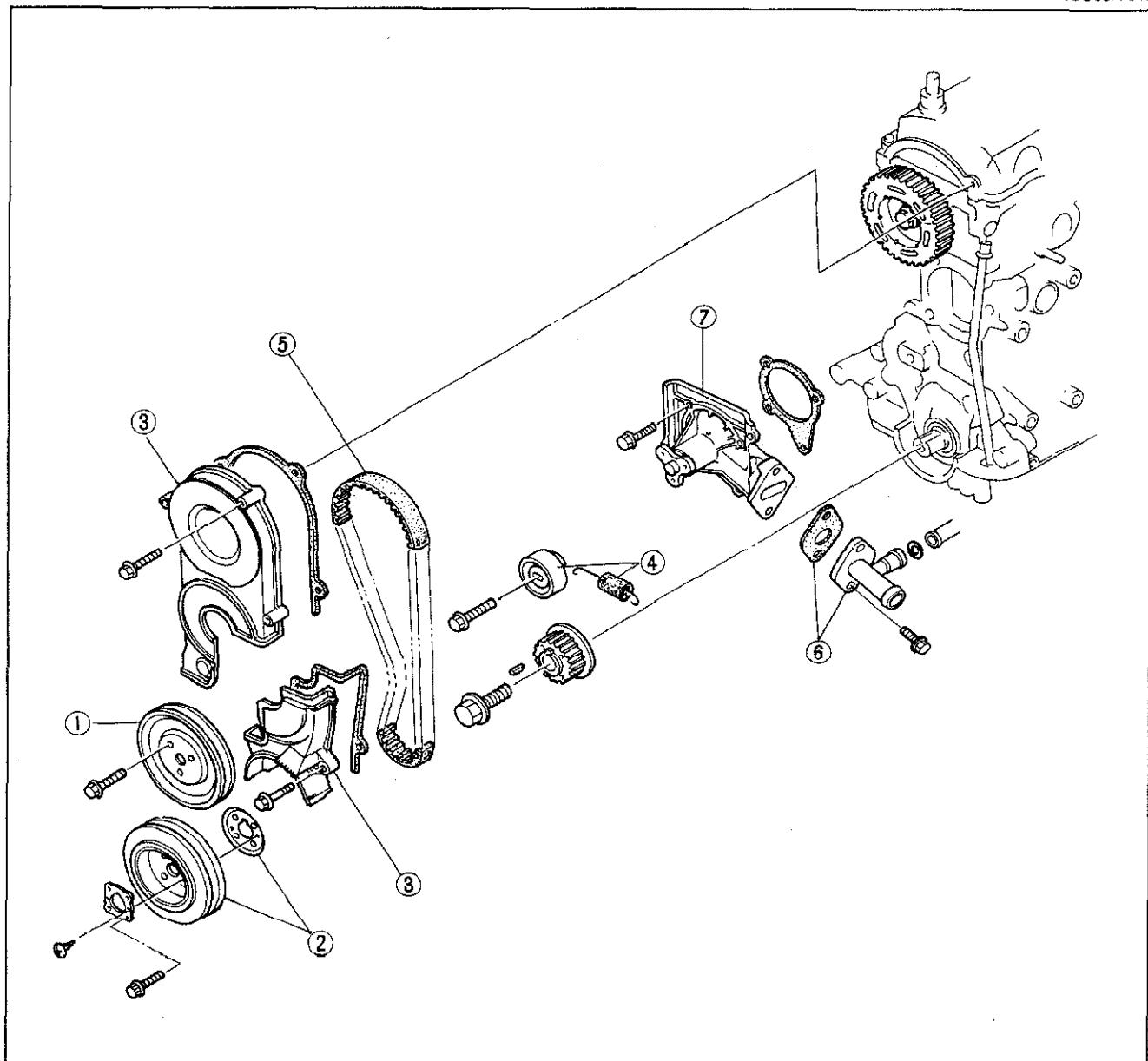

83U03A-013

- |                                     |                                  |
|-------------------------------------|----------------------------------|
| 1. Water pump pulley                | 5. Timing belt                   |
| 2. Crankshaft pulley                | 6. Coolant inlet pipe and gasket |
| 3. Timing belt cover                | 7. Water pump                    |
| 4. Timing belt tensioner and spring |                                  |

#### Note

- a) Do not disassemble the water pump, if a problem is found replace it as a unit.
- b) Position the hose clamp in the original location on the hose and squeeze it lightly with large pliers to ensure a good fit.

# COOLING SYSTEM (B6 DOHC)

<b>OUTLINE</b> .....	<b>3B— 2</b>
STRUCTURAL VIEW.....	<b>3B— 2</b>
SPECIFICATIONS.....	<b>3B— 3</b>
<b>TROUBLESHOOTING GUIDE</b> .....	<b>3B— 3</b>
<b>COOLANT</b> .....	<b>3B— 4</b>
INSPECTION.....	<b>3B— 4</b>
REPLACEMENT .....	<b>3B— 4</b>
<b>RADIATOR CAP</b> .....	<b>3B— 5</b>
INSPECTION.....	<b>3B— 5</b>
<b>ELECTRIC FAN MOTOR</b> .....	<b>3B— 5</b>
INSPECTION (FOR 2WD) .....	<b>3B— 5</b>
INSPECTION (FOR 4WD) .....	<b>3B— 6</b>
<b>WATER THERMO SWITCH</b> .....	<b>3B— 6</b>
INSPECTION.....	<b>3B— 6</b>
<b>RADIATOR SWITCH</b> .....	<b>3B— 7</b>
INSPECTION.....	<b>3B— 7</b>
<b>ELECTRIC FAN RELAY</b> .....	<b>3B— 7</b>
INSPECTION.....	<b>3B— 7</b>
<b>WATER PUMP DRIVE BELT</b> .....	<b>3B— 8</b>
INSPECTION AND ADJUSTMENT .....	<b>3B— 8</b>
<b>THERMOSTAT</b> .....	<b>3B— 9</b>
REMOVAL AND INSTALLATION.....	<b>3B— 9</b>
INSPECTION.....	<b>3B— 9</b>
<b>RADIATOR</b> .....	<b>3B—10</b>
REMOVAL AND INSTALLATION.....	<b>3B—10</b>
INSPECTION.....	<b>3B—10</b>
<b>WATER PUMP</b> .....	<b>3B—11</b>
REMOVAL AND INSTALLATION.....	<b>3B—11</b>

## OUTLINE

### STRUCTURAL VIEW

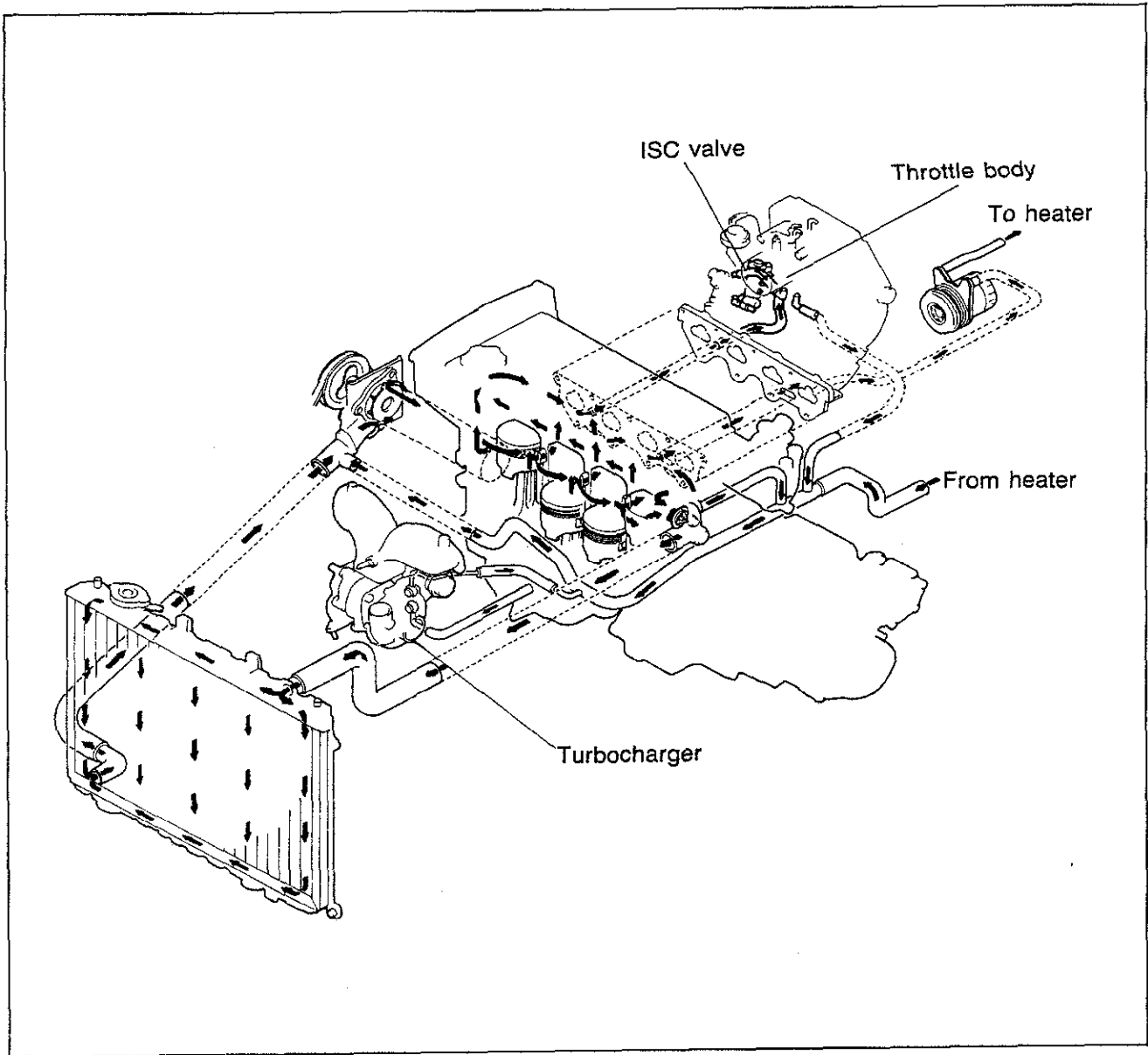

83U03B-002

## SPECIFICATIONS

Cooling system		Water-cooled, forced circulation	
Coolant capacity	With heater	liters (US qt, Imp qt.)	6.0 (6.3, 5.3)
Thermostat	Type	2 stage	
	Opening temperature	°C (°F)	SUB. 85 (185)      MAIN. 88 (190)
	Full-open temperature	°C (°F)	100 (212)
	Full-open lift	mm (in)	SUB. 1.5 (0.06) or more      MAIN. 8 (0.31) or more
Water pump	Type	Centrifugal	
Radiator	Type	Corrugated fin type	
	Cap valve pressure	kPa (kg/cm <sup>2</sup> , psi)	74—103 (0.75—1.05, 11—15)
Cooling fan	Outer diameter	mm (in)	320 (12.6)
	No. of blades		4

83U03B-003

## TROUBLESHOOTING GUIDE

Problem	Possible Cause	Remedy	Page
<b>Coolant leakage</b>	Damaged radiator core seam	Replace	3B—10
	Leakage from radiator hose or heater hose	Repair or replace	3B—10
	Leakage from water thermo switch or radiator switch	Repair or replace	3B— 6,7
	Malfunction of water pump seal	Replace	3B—11
	Damaged or loose thermostat cover or gasket	Repair or replace	3B— 9
	Loose cylinder head bolt	Refer to Section 1B	—
	Damaged cylinder head gasket	Refer to Section 1B	—
	Cracked cylinder block	Refer to Section 1B	—
	Cracked cylinder head	Refer to Section 1B	—
<b>Corrosion</b>	Impurities in coolant	Clean and flush	3B— 4
<b>Overheating</b>	Water passage clogged	Clean	3B—10
	Thermostat malfunction	Replace	3B— 9
	Radiator fins clogged	Clean	3B—10
	Water pump malfunction	Repair or replace	3B—11
	Insufficient coolant	Add	3B— 4
	Electric fan motor malfunction	Replace	3B— 5
	Electric fan relay malfunction	Replace	3B— 7
	Radiator cap malfunction	Replace	3B— 5

83U03B-004

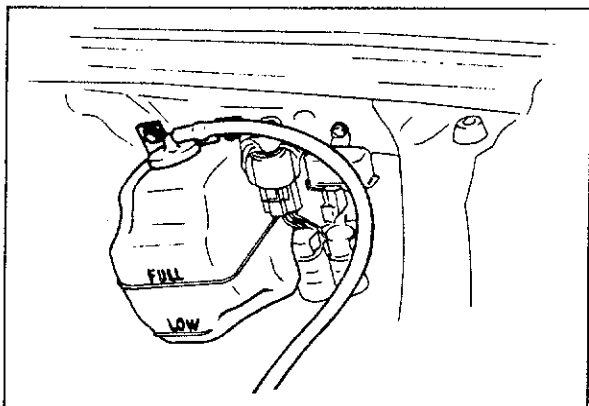

63U03X-005

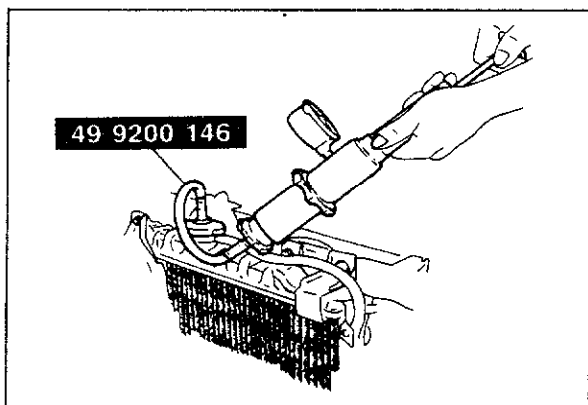

83U03A-014

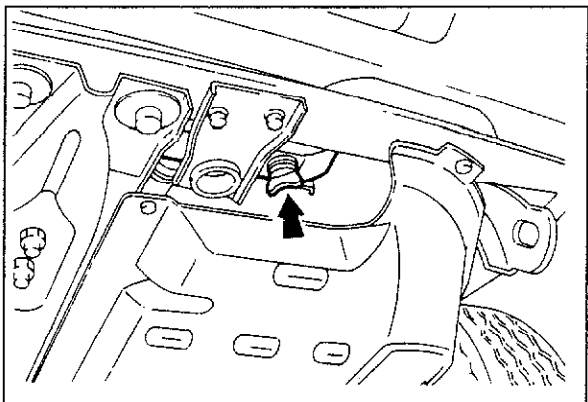

63U03X-007

## COOLANT

### INSPECTION

#### Coolant level

While the coolant is cold, the coolant level should be near the radiator inlet port, and the level in the reserve tank should be between the FULL and LOW marks. Add coolant if the level is low.

#### Coolant leakage

1. Connect the tester with **SST** to the radiator inlet port.
2. Apply a pressure of **103 kPa (1.05 kg/cm<sup>2</sup>, 15 psi)** to the tester.
3. Note if the tester indicator shows a reduction of pressure. If it does, there may be a coolant leak. Check for leaks.

#### Warning

**When removing either the radiator cap or the tester with adapter, loosen it slowly until the pressure in the radiator is released, and then remove it.**

### REPLACEMENT

1. Drain the coolant by opening the radiator drain plug.
2. Close the plug tightly.
3. After pouring anti-freeze into the radiator in accordance with the table below, add soft water.
4. Start engine, bleed the air from the coolant passages, and then add coolant as necessary.

#### Anti-freeze solution mixture percentage

Protection	Mixture percentage (by volume)	
	Anti-freeze solution	Water
Above -16°C (3°F)	35	65
Above -26°C (-15°F)	45	55
Above -40°C (-40°F)	55	45

83U03A-004

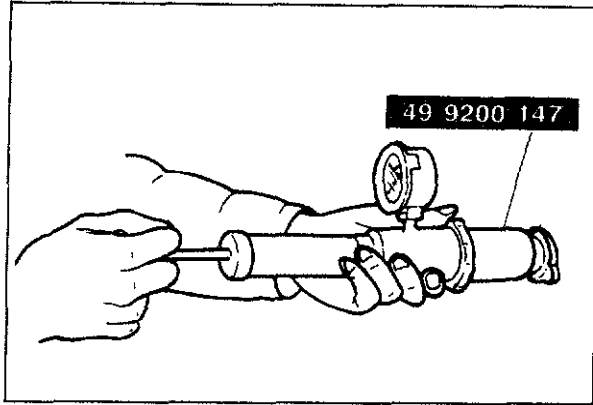

83U03A-015

## RADIATOR CAP

### INSPECTION

#### Radiator Cap Valve

1. Remove foreign material (water residue, etc.) from between the radiator cap valve and the valve seat.
2. Attach the radiator cap with **SST** to a tester. Apply pressure gradually to **74—103 kPa (0.75—1.05 kg/cm<sup>2</sup>, 11—15 psi)**.
3. Wait about 10 seconds, and check whether the pressure has decreased.  
The cap is normal if the pressure is, maintained for about 10 seconds.

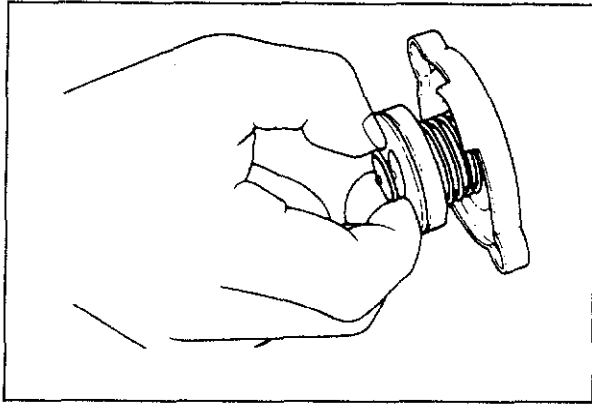

63U03X-009

#### Negative-Pressure Valve

1. Pull the negative-pressure valve to open it. Check that it closes completely when released.
2. Check for damage on the contact surfaces, cracked or deformed seal packing. Replace the radiator cap if necessary.

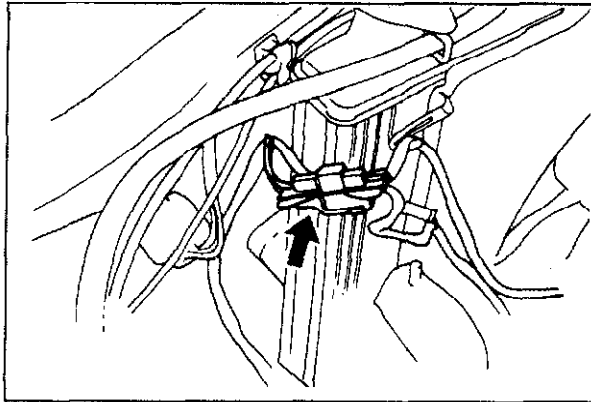

83U03B-005

## ELECTRIC FAN MOTOR

### INSPECTION (FOR 2WD)

1. Disconnect the fan motor connectors.
2. Confirm that the battery voltage is approx. 12V.

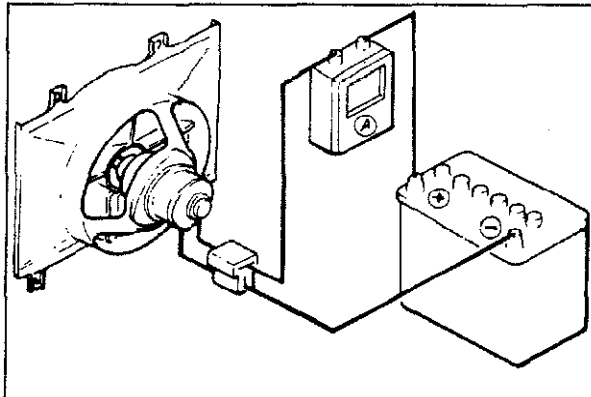

83U03B-006

3. Connect an ammeter and battery to the fan motor connectors.
4. Check that the fan motor operates smoothly at the standard current or less.

**Standard current: 10.0—11.0 Amperes**

5. If the fan motor is faulty, replace it.



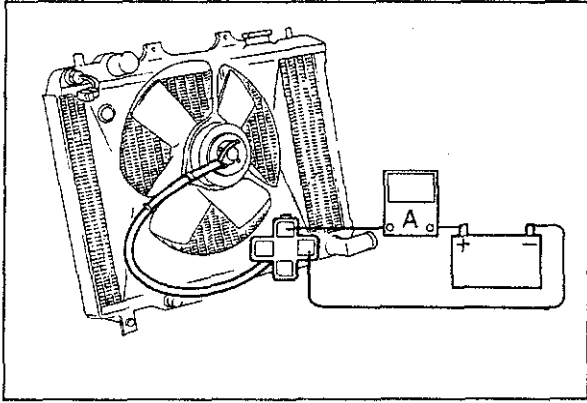

83U03B-007

## INSPECTION (FOR 4WD)

1. Disconnect the fan motor connectors.
2. Confirm that the battery voltage is approx. 12V.
3. Connect an ammeter and battery to the fan motor connectors for low speed inspection.
4. Check that the fan motor operates smoothly at the standard current or less.

**Standard current: 8.8—9.7 Amperes**

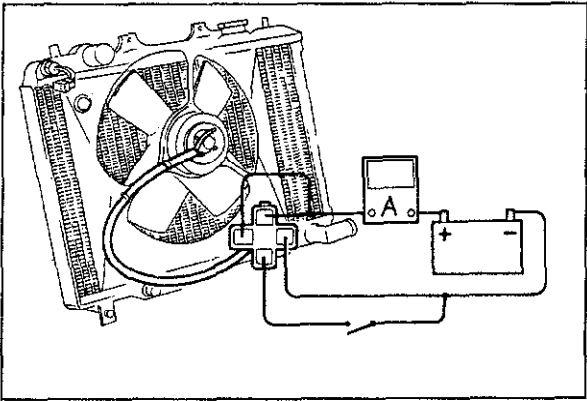

83U03B-008

5. Connect an ammeter, battery and switch to the fan motor connectors for high speed inspection.
6. Check that the fan motor operates smoothly at the standard current or less with the switch ON.

**Standard current: 13.3—14.6 Amperes**

7. If the fan motor is faulty, replace it.

## WATER THERMO SWITCH

### INSPECTION

1. Remove the electric fan water thermo switch.

#### Warning

**Do not disconnect the water thermo switch connector while the ignition switch is ON because the fan will turn.**

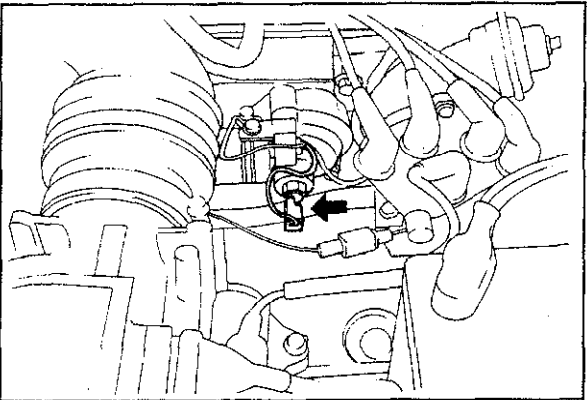

83U03B-015

2. Place the water thermo switch in a container of water.
3. Connect a circuit tester to the water thermo switch.
4. Check that continuity is not indicated when the water temperature is **97°C (207°F)** or higher, and that continuity is indicated when the temperature is **90°C (194°F)** or less.
5. If the water thermo switch is faulty, replace it.

#### Note

- a) Use a new O-ring when installing the water thermo-switch. Do not use seal tape on the threads of the thermo switch.
- b) Check for water leakage after installation.

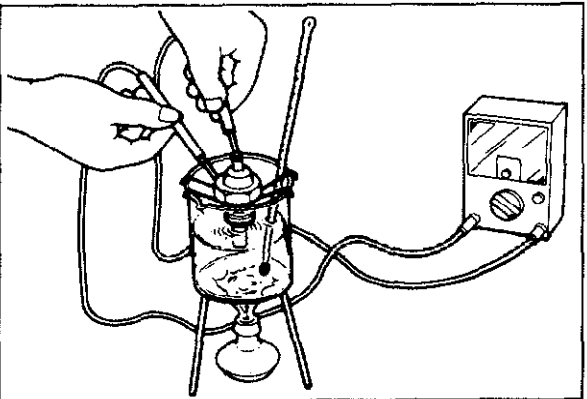

83U03B-007

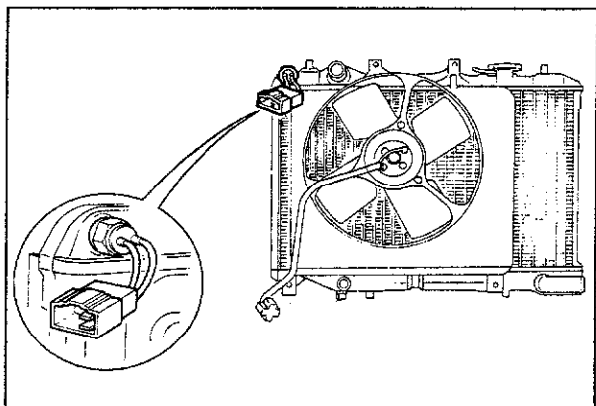

83U03B-009

## RADIATOR SWITCH (FOR 4WD)

### INSPECTION

1. Remove the radiator switch.

#### Warning

**Do not disconnect the radiator switch connector while the ignition switch is ON because the fan will turn.**

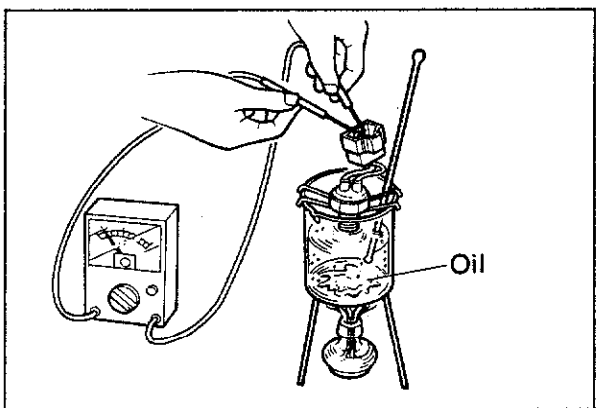

83U03B-010

2. Place the radiator switch in a container of engine oil.
3. Connect a circuit tester to the radiator.
4. Check that continuity is not indicated when the oil temperature is **105°C (221°F)**, and that continuity is indicated when the temperature is **96°C (205°F)**.

#### Warning

**Do not heat the engine oil above 120°C (248°F).**

5. If the radiator switch is faulty, replace it.

#### Note

**Clean the engine oil on the switch when the switch is reused.**

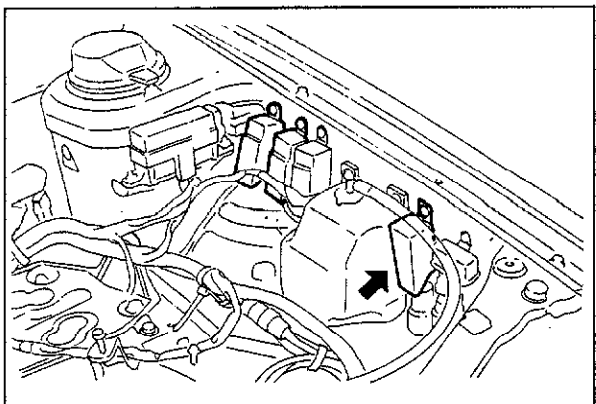

83U03B-011

## ELECTRIC FAN RELAY

### INSPECTION

1. Disconnect the water thermo switch connector, and then check whether the fan turns when the ignition switch is turned ON. If it does, the relay is functioning properly.

2. If the fan doesn't turn on, check the continuity of the fan relay.

- (1) Check for continuity between (a) and (b) terminals, (c) and (d) terminals.
- (2) Check that there is no continuity between (a) and (b) terminals when 12V battery is applied across (c) and (d) terminals.

3. If the relay is faulty replace, if not, check the fuse and wiring harness, and for poor contact or a loose coupler.

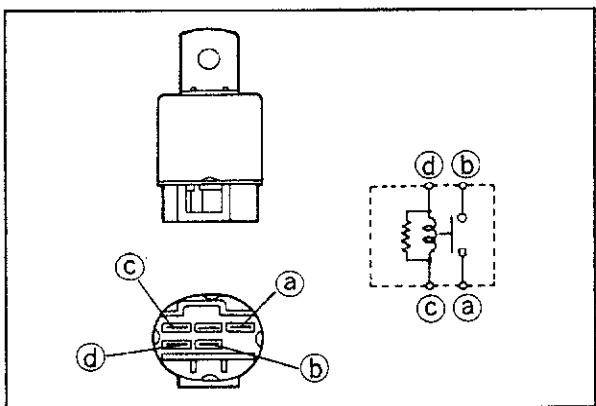

83U03B-012

# 3B ELECTRIC FAN RELAY, WATER PUMP DRIVE BELT

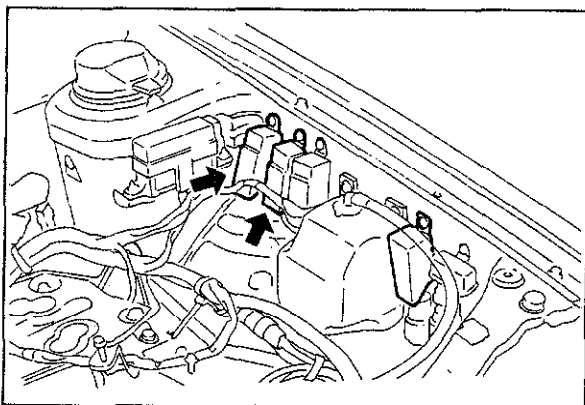

83U03B-013

## (For 4WD)

After inspection of electric fan relay, inspect the No. 1 and No. 2 relay for high speed operation.

1. Disconnect the radiator switch connector, and check for fan rotation with the ignition switch ON. If the fan rotates, the relay is functioning properly.

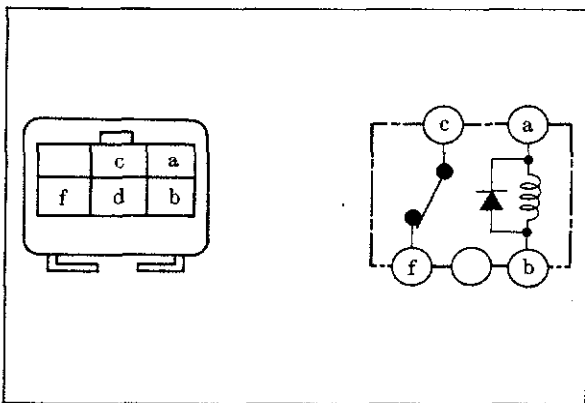

83U03B-014

2. If the fan does not turn on, check the continuity of the No. 1 and No. 2 relay.

(1) Check for continuity between (a) and (b) terminals, (c) and (f) terminals.

(2) Check that there is no continuity between (c) and (f) terminals when 12V battery is applied across (a) and (b) terminals.

3. If the relay is faulty replace, if not, check the fuse and wiring harness, and for poor contact or a loose coupler.

## Note

No. 1 and No. 2 relay are same.

## WATER PUMP DRIVE BELT

### INSPECTION AND ADJUSTMENT

1. Check all surfaces of the V-belt. Replace it if it is cracked or damaged.
2. Check the amount of deflection (at point half-way between the water pump pulley and the alternator pulley) by applying a pressure of about **98N (10 kg, 22 lb)**.

### Deflection

New: 8—9 mm (0.31—0.35 in)

Used: 9—10 mm (0.35—0.39 in)

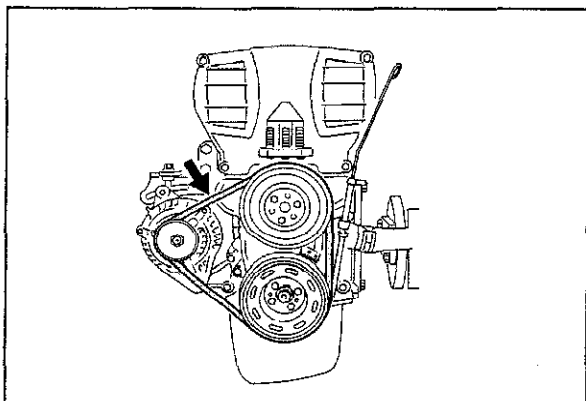

63U03X-015

## THERMOSTAT

### REMOVAL AND INSTALLATION

1. Drain the coolant.
2. Remove the parts in the numbered sequence shown in the figure.
3. Install in the reverse order of removal.

83U03A-008

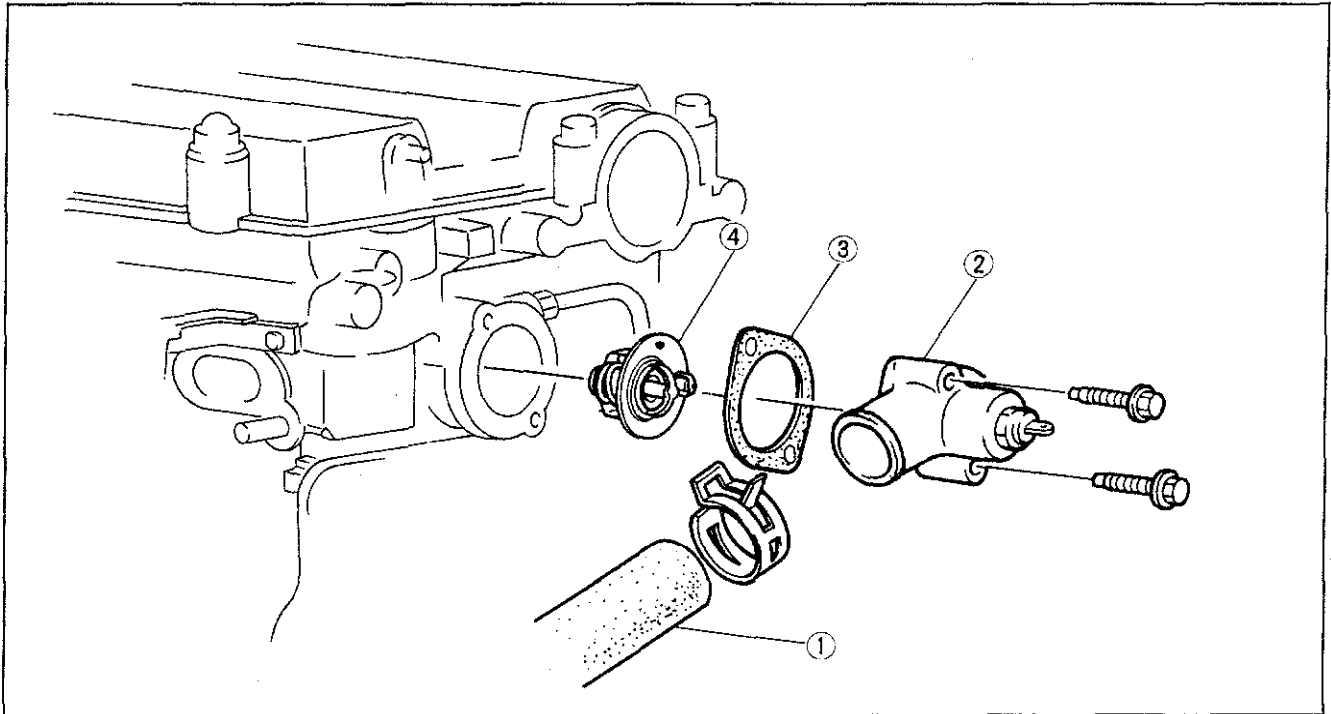

83U03A-009

1. Water hose
2. Thermostat cover
3. Gasket
4. 2 stage thermostat

#### Note

- a) The jiggle pin should be on the upper side.
- b) Position the hose clamp in the original location on the hose and squeeze it lightly with large pliers to ensure a good fit.

### INSPECTION

Check the operation. Replace if necessary.

1. Visually check the valve to be sure it is air tight.
2. Place the thermostat and a thermometer in water, gradually increase the water temperature, and then check the following:
  - (1) Valve opening temperature
    - Sub-valve **83.5—86.5°C (182—188°F)**
    - Main valve **86.5—89.5°C (188—193°F)**
  - (2) Full open lift
    - Sub-valve **1.5 mm (0.06 in)** or more at **100°C (212°F)**
    - Main valve **8 mm (0.31 in)** or more at **100°C (212°F)**
  - (3) Valve closing temperature
    - Sub-valve **80°C (176°F)**
    - Main valve **83°C (181°F)**

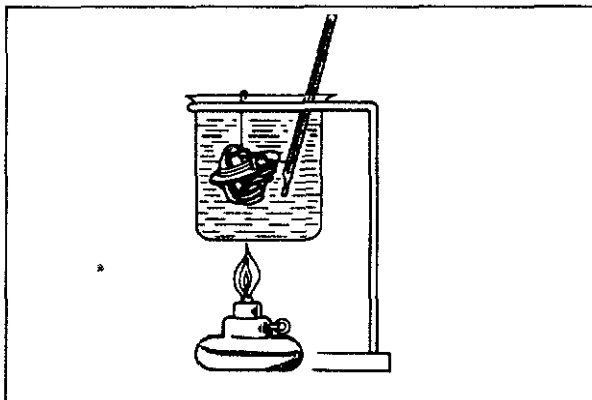

83U03X-017

## RADIATOR

### REMOVAL AND INSTALLATION

1. Drain the coolant.
2. Remove the parts in the numbered sequence shown in the figure.
3. Install in the reverse order of removal.

83U03A-010

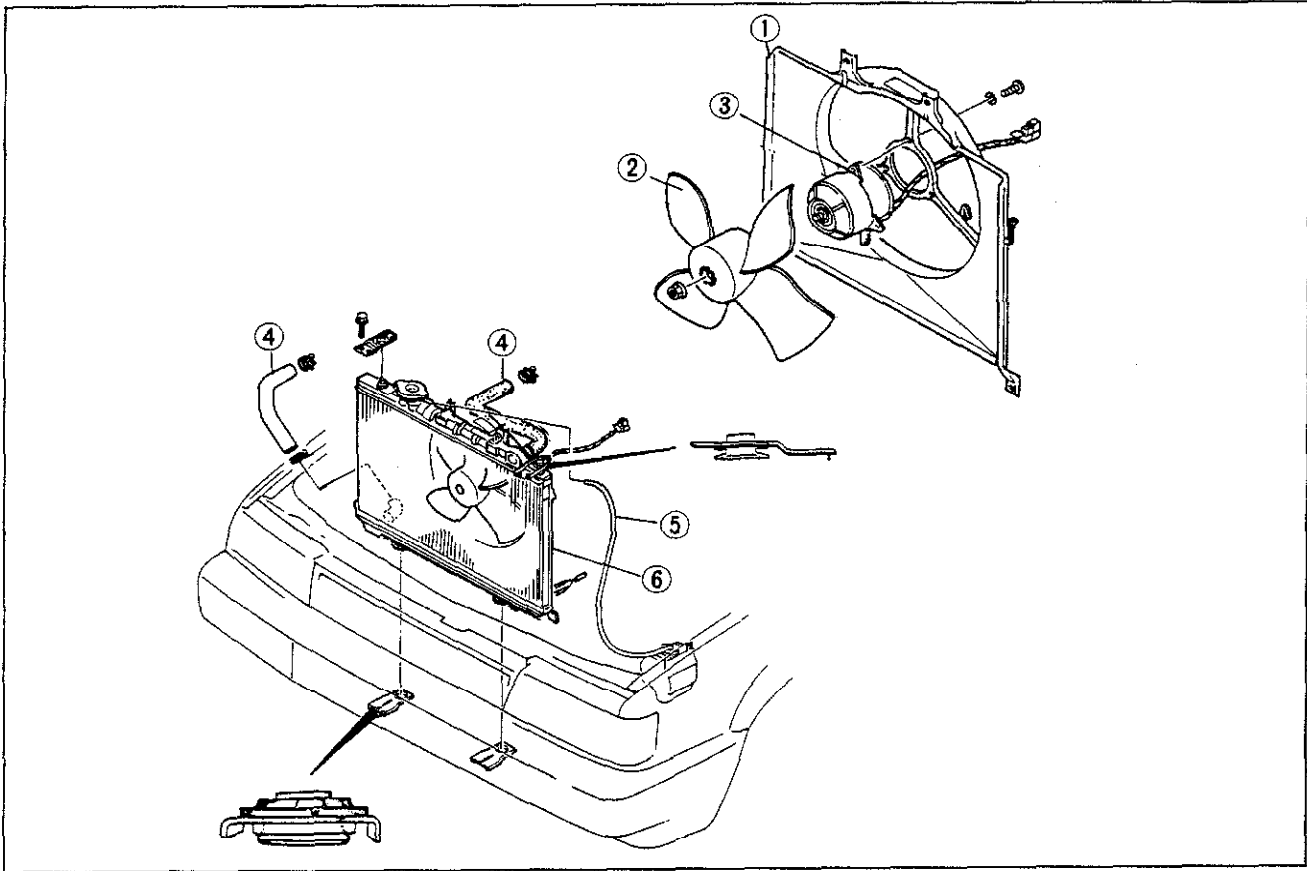

83U03A-011

- |                      |                      |
|----------------------|----------------------|
| 1. Radiator cowling  | 4. Radiator hose     |
| 2. Cooling fan       | 5. Reserve tank hose |
| 3. Cooling fan motor | 6. Radiator          |

#### Note

Position the hose clamp in the original location on the hose and squeeze it lightly with large pliers to ensure a good fit.

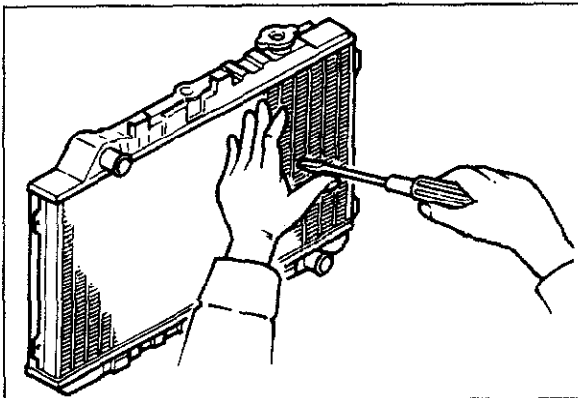

63U03X-019

#### INSPECTION

Check the following points; repair or replace if necessary:

1. Cracks, damage, or water leakage
2. Bent fins (repair by using a screwdriver)
3. Distorted or damaged radiator inlet.

## WATER PUMP

### REMOVAL AND INSTALLATION

1. Turn the crankshaft so that the No. 1 cylinder is at top dead center of compression.
2. Drain the engine coolant.
3. Remove the parts in the numbered sequence shown in the figure.
4. Install in the reverse order of removal.

83U03A-012

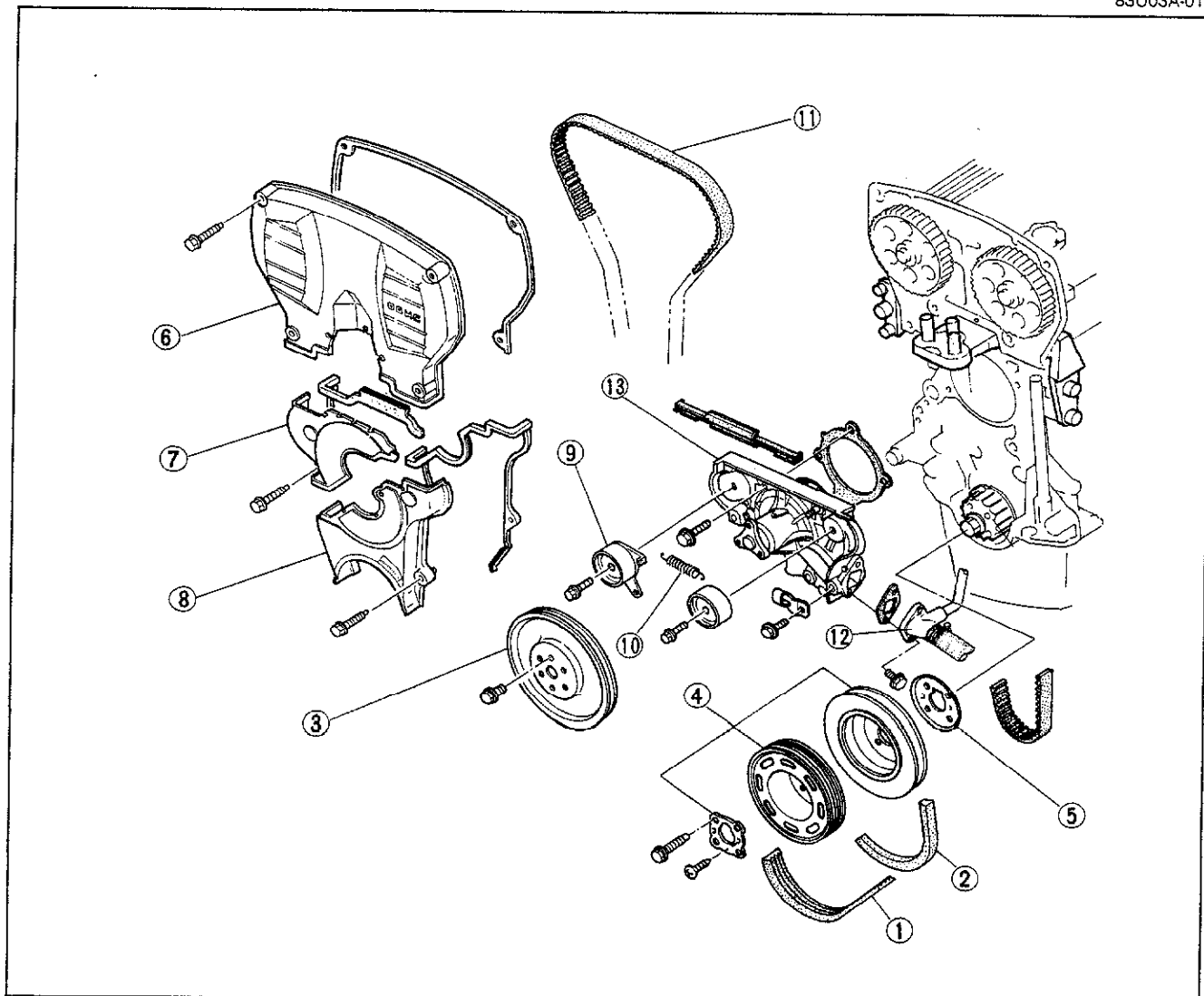

83U03B-015

- |                                     |                               |
|-------------------------------------|-------------------------------|
| 1. Drive belt (with P/S and or A/C) | 7. Timing belt cover (middle) |
| 2. Drive belt                       | 8. Timing belt cover (lower)  |
| 3. Water pump pulley                | 9. Timing belt tensioner      |
| 4. Crankshaft pulley                | 10. Tensioner spring          |
| 5. Baffle plate                     | 11. Timing belt               |
| 6. Timing belt cover (upper)        | 12. Coolant inlet pipe        |
|                                     | 13. Water pump assembly       |

#### Note

- a) Do not disassemble the water pump, if a problem is found replace it as a unit.
- b) Position the hose clamp in the original location on the hose and squeeze it lightly with large pliers to ensure a good fit.

# FUEL AND EMISSION CONTROL SYSTEMS (NON-TURBO)

<b>OUTLINE</b> .....	4A— 2	<b>DECELERATION CONTROL</b>	
SYSTEM DIAGRAM .....	4A— 2	<b>SYSTEM</b> .....	4A—47
EMISSION COMPONENT LOCATION .....	4A— 3	<b>HIGH ALTITUDE COMPENSATION</b>	
VACUUM HOSE ROUTING		<b>SYSTEM</b> .....	4A—50
DIAGRAM .....	4A— 4	<b>EVAPORATIVE EMISSION</b>	
COMPONENT DESCRIPTIONS .....	4A— 5	<b>CONTROL SYSTEM</b> .....	4A—52
SPECIFICATIONS .....	4A— 7	SYSTEM INSPECTION .....	4A—53
<b>TROUBLESHOOTING GUIDE</b> .....	4A— 8	NO.1 PURGE CONTROL VALVE ...	4A—54
RELATIONSHIP CHART .....	4A— 8	NO.2 PURGE CONTROL VALVE ...	4A—54
TROUBLESHOOTING CHART .....	4A—10	THREE-WAY SOLENOID VALVE ...	4A—54
<b>TROUBLESHOOTING WITH SST</b> ....	4A—12	VACUUM SWITCH VALVE .....	4A—55
SELF-DIAGNOSIS CHECKER		THREE-WAY CHECK VALVE .....	4A—55
(49 H018 9A1) .....	4A—12	<b>POSITIVE CRANKCASE VENTILATION</b>	
INSPECTION PROCEDURE .....	4A—13	<b>(PCV) SYSTEM</b> .....	4A—56
<b>MONITOR SWITCH FUNCTION</b> .....	4A—20	<b>CONTROL SYSTEM</b> .....	4A—57
INSPECTION PROCEDURE .....	4A—21	MAIN FUSE .....	4A—58
<b>IDLE ADJUSTMENT</b> .....	4A—24	MAIN RELAY .....	4A—58
<b>INTAKE AIR SYSTEM</b> .....	4A—25	CIRCUIT OPENING RELAY .....	4A—58
REMOVAL AND INSTALLATION ....	4A—26	ENGINE CONTROL UNIT .....	4A—60
PARTS INSPECTION .....	4A—28	NEUTRAL SWITCH (MTX) .....	4A—63
<b>IDLE SPEED CONTROL (ISC)</b>		CLUTCH SWITCH (MTX) .....	4A—63
<b>SYSTEM</b> .....	4A—29	INHIBITOR SWITCH .....	4A—63
OUTLINE .....	4A—29	BRAKE SWITCH .....	4A—63
TROUBLESHOOTING CHART .....	4A—30	E/L CONTROL UNIT .....	4A—64
<b>FUEL SYSTEM</b> .....	4A—33	AIR FLOW METER .....	4A—65
FUEL PRESSURE RELEASE AND		THROTTLE SENSOR .....	4A—66
SERVICING FUEL SYSTEM .....	4A—34	INTAKE AIR THERMO SENSOR ....	4A—68
MULTI-PRESSURE TESTER		WATER THERMO SENSOR .....	4A—68
(49 9200 750A) .....	4A—35	WATER THERMO SWITCH .....	4A—70
TROUBLESHOOTING CHART .....	4A—37	OXYGEN SENSOR (O <sub>2</sub> SENSOR) ...	4A—69
FUEL PRESSURE .....	4A—38	ATMOSPHERIC PRESSURE	
INSPECTION .....	4A—40	SENSOR .....	4A—70
REPLACEMENT .....	4A—44	<b>EXHAUST SYSTEM</b> .....	4A—71
FUEL TANK .....	4A—46		

## OUTLINE

### SYSTEM DIAGRAM

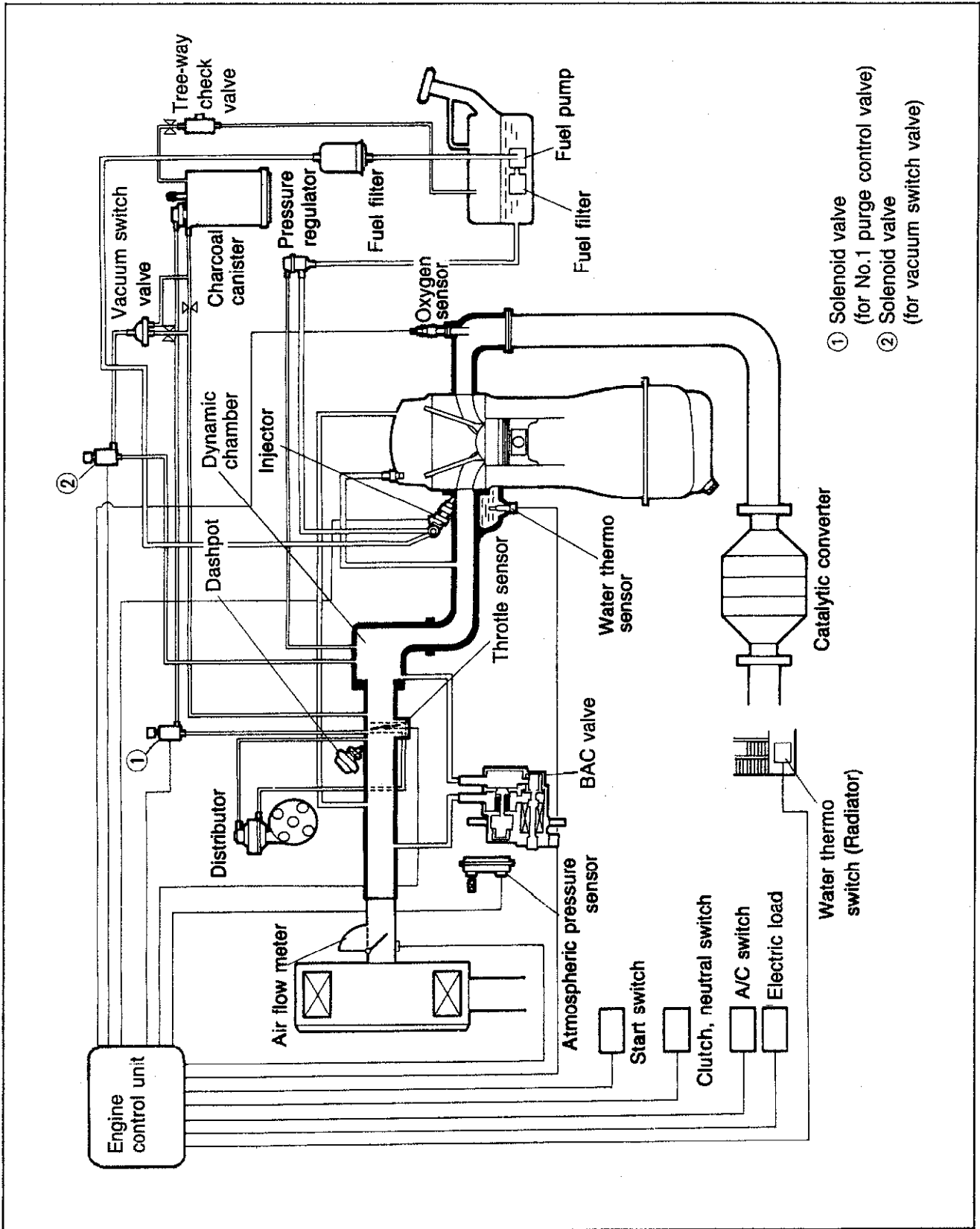

83U04A-002



EMISSION COMPONENT LOCATION

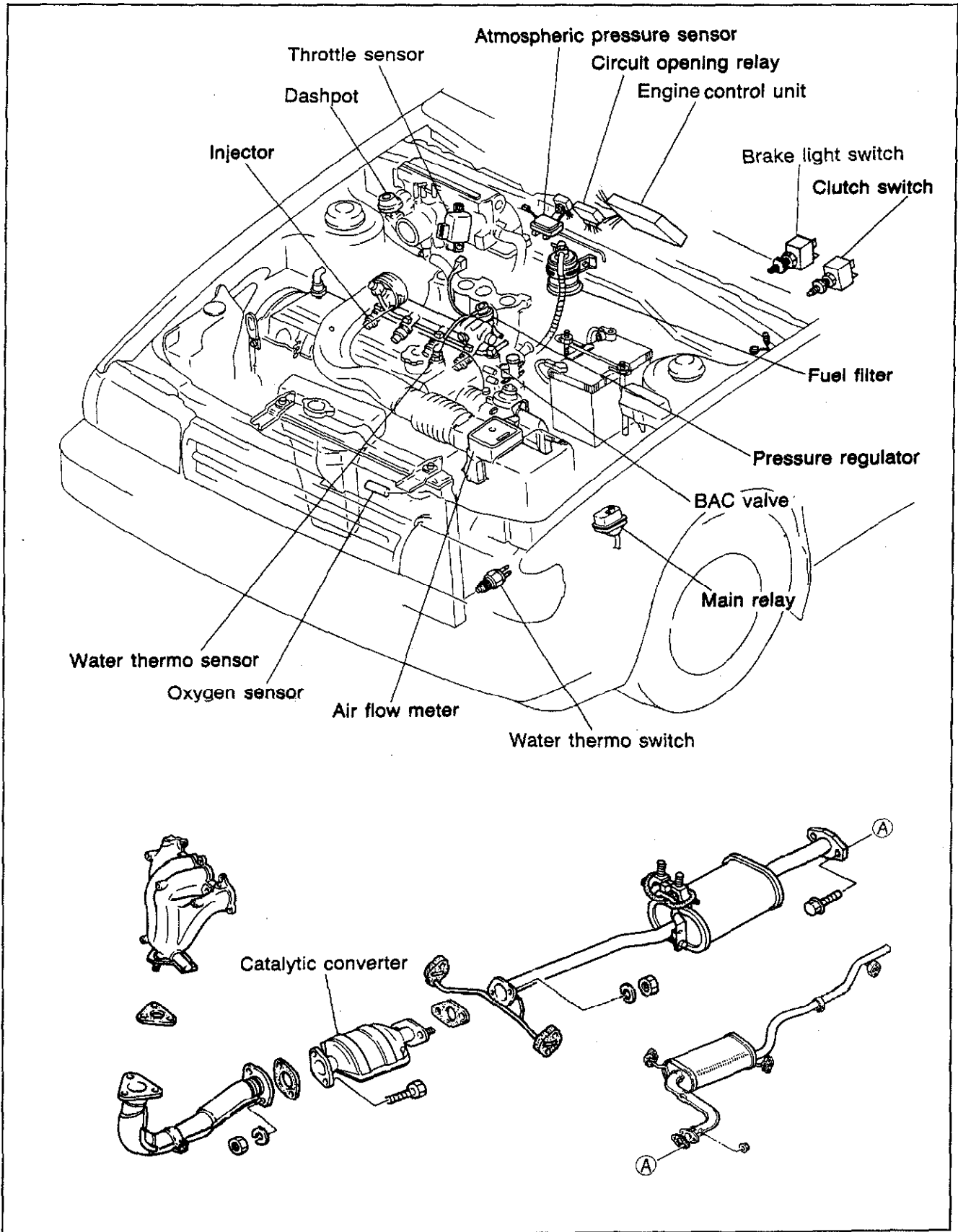

83U04A-003

## VACUUM HOSE ROUTING DIAGRAM

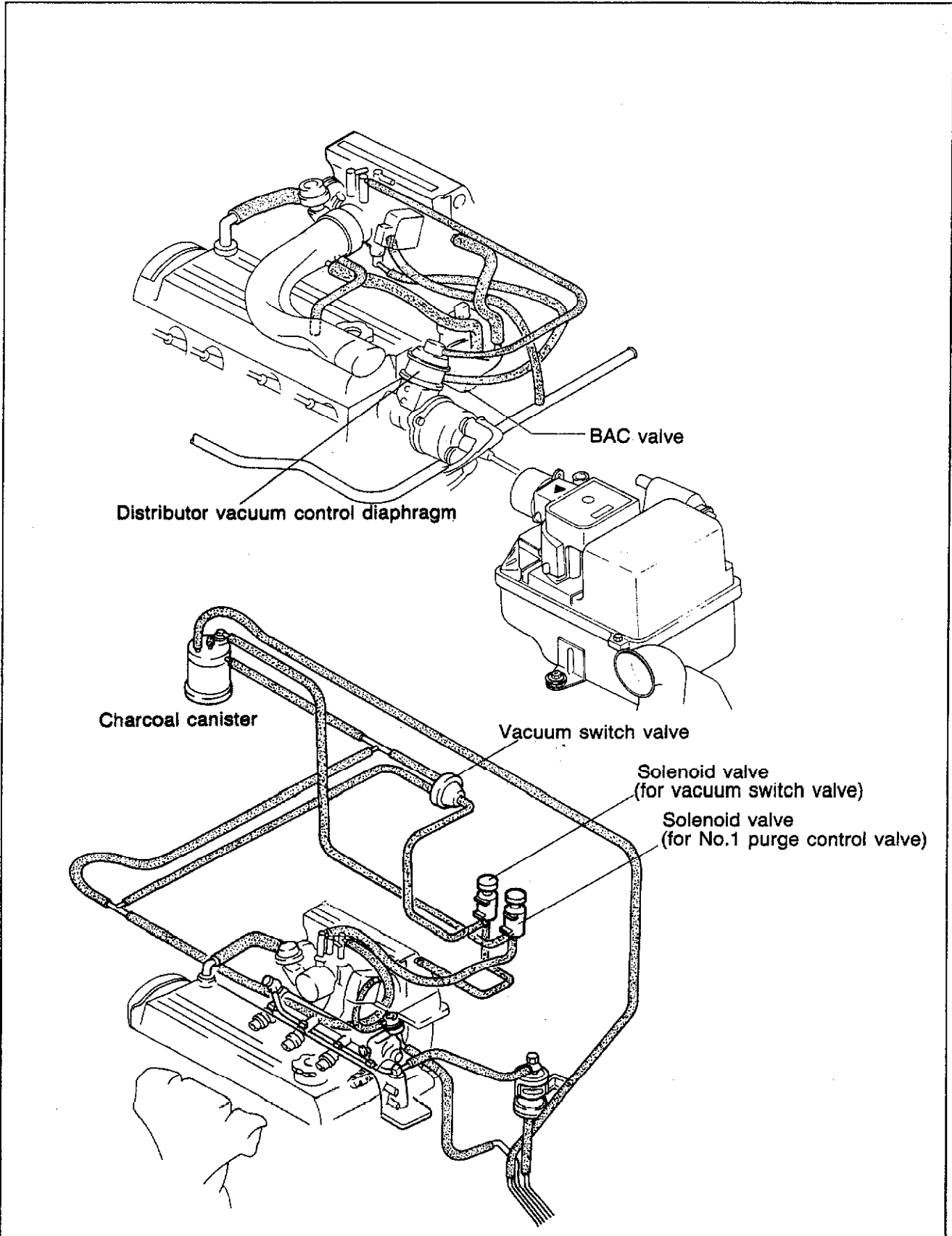

83U04A-004

## COMPONENT DESCRIPTIONS

No.	COMPONENT	FUNCTION	REMARKS
1	Air cleaner	Filters air into the combustion chamber	
2	Air flow meter	Detects intake air amount; sends signal to the engine control unit. (for determination of fuel injection amount)	Intake air thermo sensor and fuel pump switch are integrated.
3	Atmospheric pressure sensor	Detects atmospheric pressure to prevent over rich mixture; sends signal to engine control unit.	
4	Air valve	When engine is cold, supplies bypass air into dynamic chamber for quick warm-up and smooth idle.	<ul style="list-style-type: none"> <li>• Engine speed is increased to shorten warm-up period.</li> <li>• Thermo wax type</li> <li>• Installed into BAC valve</li> </ul>
5	Brake light switch	Detects brake operation (deceleration); sends signal to engine control unit.	
6	Catalytic converter	Reduce HC and CO by oxidation. Reduce NOx.	Honeycomb construction
7	Charcoal canister	Stores fuel tank fumes while engine is stopped.	
8	Check connector	For Self-diagnosis checker	6 pin connector (Green)
9	Circuit opening relay	Supplies voltage for fuel pump while engine running.	
10	Clutch switch	Detects in-gear condition; sends signal to engine control unit.	Switch is closed when clutch pedal is released.
11	Engine control unit	Detects the following; <ol style="list-style-type: none"> <li>1. Engine speed</li> <li>2. Intake air amount</li> <li>3. Engine coolant temperature</li> <li>4. Engine load condition</li> <li>5. Oxygen concentration in exhaust gas</li> <li>6. In-gear condition</li> <li>7. Intake air temperature</li> <li>8. Atmospheric pressure</li> <li>9. A/C operation</li> <li>10. P/S operation</li> <li>11. E/L (Electrical load) operation</li> <li>12. Starting signal</li> <li>13. Initial set signal</li> </ol> Controls operation of the following; <ol style="list-style-type: none"> <li>1. Fuel injection amount</li> <li>2. Idle speed control system</li> <li>3. Fail-safe system</li> <li>4. Monitor switch function</li> </ol>	<ol style="list-style-type: none"> <li>1. Ignition coil (-) terminal</li> <li>2. Air flow meter</li> <li>3. Water thermo sensor</li> <li>4. Throttle sensor (Point type)</li> <li>5. Oxygen sensor</li> <li>6. Clutch switch and neutral switch</li> <li>7. Intake air thermo sensor (in air flow meter)</li> <li>8. Atmospheric pressure sensor</li> <li>9. A/C switch</li> <li>10. P/S switch</li> <li>11. E/L switch</li> <li>12. Starter switch (Ignition switch)</li> <li>13. Test terminal</li> </ol> <ol style="list-style-type: none"> <li>1. Injector</li> <li>2. BAC valve (ISC solenoid valve)</li> <li>3. Self-diagnosis checker and MIL</li> <li>4. Monitor lamp (Self-diagnosis checker)</li> </ol>
12	Dashpot	Gradually allows throttle valve closing during deceleration.	Adjustment speed MTX...2800 ± 150 rpm ATX ....2800 ± 300 rpm (in neutral)
13	Fuel filter	Filters particles from fuel	
14	Fuel pump	Provides fuel to injectors	<ul style="list-style-type: none"> <li>• Operates while engine is running</li> <li>• Installed in fuel tank</li> </ul>
15	Intake air thermo sensor	Detects intake air temperature; compensates fuel injection amount through engine control unit.	Thermistor
16	Injector	Injects fuel to intake port	Controlled by signals from engine control unit.
17	Intank Filter	Filters particles from fuel	Installed in low-pressure side

# 4A OUTLINE

No.	COMPONENT	FUNCTION	REMARKS
18	ISC valve	Supplies bypass air to dynamic chamber for smooth idle	Insalled into BAC valve
19	Neutral switch	Detects transaxle condition; sends signal to control unit	
20	Oxygen Sensor	Detects oxygen concentration in exhaust gas; sends signal to control unit; compensates fuel injection amount.	Zirconia ceramic with platinum coating
21	Pressure Regulator	Regulates fuel pressure to injectors	
22	No.1 Purge Control Valve	Opens and closes evaporative vapor passage from canister to intake manifold	During open throttle
23	No.2 Purge Control Valve	Positive pressure and negative pressure valves operate in accordance with fuel tank pressure.	Prevents canister from flooding.
24	Throttle Sensor (Point type)	Detects throttle opening angle; sends signal to engine control unit; compensates fuel injection amount.	
25	Solenoid Valve (for No.1 purge control valve)	Opens and closes vacuum passage to No.1 purge control valve.	Controlled by signal from engine control unit
	Solenoid Valve (for vacuum switch valve)	Opens and closes vacuum passage to vacuum switch valve.	Controlled by signal from engine control unit
26	Vacuum Switch Valve	Opens passage of vacuum line when vacuum applied.	Vacuum from three-way solenoid valve
27	Water Thermo Sensor	Detects coolant temperature; sends signal to engine control unit; compensates fuel injection amount.	Thermistor
28	Water Thermo Switch	Detects radiator coolant temperature; sends signal to control unit; increases fuel injection amount.	Above 17°C (63°F): ON

83U04A-005

**SPECIFICATIONS**

Item	Transaxle type	Manual transaxle	Automatic transaxle
Idle speed	rpm	850 ± 50 in Neutral	850 ± 50 in P range
<b>Throttle body</b>			
Type		Horizontal draft (1-barrel)	
Throat diameter	mm (in)	45 (1.77)	
<b>Air flow meter</b>			
Resistor	Ω	E2—Vs	Fully closed: 20—400 Fully open: 20—1,000
		E2—Vc	100—300
		E2—Vb	200—400
		E2—THA	-20°C (-4°F) 10,000—20,000 20°C (68°F) 2,000—3,000 60°C (140°F) 400—700
<b>Fuel pump</b>			
Type		Impeller (in tank)	
Output pressure	kPa (kg/cm <sup>2</sup> , psi)	441—588 (4.5—6.0, 64.0—85.3)	
Feeding capacity	cc (cu-in)/10 sec	220—380 (13.4—23.2) when fuel pressure at 250 kPa (2.55 kg/cm <sup>2</sup> , 36.3 psi)	
<b>Fuel filter</b>			
Type	Low pressure side	Nylon 6 (250 mesh) element	
	High pressure side	Paper element	
<b>Pressure regulator</b>			
Type		Diaphragm	
Regulating pressure	kPa (kg/cm <sup>2</sup> , psi)	240—279 (2.45—2.85, 34.8—40.5) (Vacuum hose disconnected)	
<b>Injector</b>			
Type		High-ohmic	
Type of drive		Voltage	
Resistance	Ω	11—15	
Injection amount	cc (cu in)/15 sec	32—41 (1.95—2.50)	
<b>Idle speed control valve</b>			
Solenoid resistance	Ω	5—20	
<b>Fuel tank</b>			
Capacity	liters (US gal, Imp gal)	48 (12.7, 10.6)	
<b>Air cleaner</b>			
Element type		Wet	
<b>Accelerator cable</b>			
Free play	mm (in)	1—3 (0.039—0.118)	
<b>Fuel</b>			
Specification		Unleaded gasoline	

83U04A-006

## TROUBLESHOOTING GUIDE

### RELATIONSHIP CHART

#### Output Devices and Input Devices

OUTPUT DEVICE  INPUT DEVICE	INJECTOR		SOLENOID (PRES- SURE RE- GULATOR)	BAC VALVE		PURGE SOLENOID	
	FUEL IN- JECTION AMOUNT	FUEL IN- JECTION TIMING		AIR VALVE	ISC VALVE	No.1	No.2
IGNITION COIL	○	○	X	X	○	X	○
AIRFLOW METER	○	X	X	X	X	X	○
IDLE SWITCH	○	X	○	X	○	X	X
PSW SWITCH	○	X	X	X	X	X	X
WATER THERMO SENSOR	○	X	○	X	○	○	X
INTAKE AIR THERMO SENSOR	○	X	○	X	○	○	X
ATMOSPHER- IC PRESSURE SENSOR	○	X	X	X	○	X	X
OXYGEN SENSOR	○	X	X	X	○	○	X
BRAKE LIGHT SWITCH	○	X	X	X	X	X	X
WATER THERMO SWITCH	○	X	X	X	○	○	X
NEUTRAL AND CLUTCH SWITCH	○	X	○	X	○	○	X
STARTER SWITCH	○	X	○	X	X	X	X
E/L SWITCH	X	X	X	X	○	X	X
A/C SWITCH	X	X	X	X	○	X	X
P/S SWITCH	X	X	X	X	○	X	X
TEST CONNECTOR	X	X	X	X	○	X	X

○ : Related  
X : Not related  
83U04A-007

## Output Devices and Engine Condition

ENGINE CONDITION OUTPUT DEVICES		CRANKING (COLD ENGINE)	WARMING UP (DURING IDLE)	MEDIUM LOAD		ACCELERATION	HEAVY LOAD	DECELERATION	IDLE (THROTTLE VALVE FULLY CLOSED)	IGN: ON (ENGINE NOT RUNNING)	REMARKS
				COLD	WARM						
INJECTOR	INJECTION (Air Fuel Mixture)	Rich		Rich and Lean	Rich		Fuel cut off	Rich	Does not inject		
	INJECTION TIMING	1 Group						1 Group			Above 6,400 rpm fuel cut off
BAC VALVE	AIR VALVE	* Open		Closed						* Coolant temp: below 60°C (140°F)	
	ISC VALVE	Large amount of bypass air	Small amount of bypass air				* Large and small amount of bypass air	Does not operate	* Test connector grounded: small amount of air		
PURGE CONTROL SOLENOID	No.1	OFF (Vacuum cut off)		* ON (Vacuum to No.1 purge control valve)				OFF (Vacuum cut off)		* Engine speed: Above 1,500 rpm	
	No.2	OFF (Vacuum cut off)	* ON (Vacuum to vacuum switch valve)			OFF (Vacuum cut off)					

## TROUBLESHOOTING CHART

POSSIBLE CAUSE		INPUT DEVICES						OUTPUT DEVICES			
		Ignition coil	Air flow meter	Water thermo sensor	Intake air thermo sensor (In Air flow meter)	Atmospheric pressure sensor	Oxygen sensor	Feedback system	Solenoid valve (No.1 purge control valve)	Solenoid valve (Vacuum switch valve)	BAC Valve (idle speed control)
SYMPTOM		4A-14	4A-14	4A-15	4A-16	4A-17	4A-18	4A-18	4A-19	4A-19	4A-19
1	Fault Indicated by SST Code No.	01	08	09	10	14	15	17	26	27	34
2	Hard start or won't start (Crank OK)	<b>TROUBLESHOOTING PROCEDURE:</b> <b>Note</b> <b>Step 1 under symptom is to quickly determine what system or parts may be at fault by use of the SST. (Self-Diagnosis checker 49 H018 9A1)</b> <b>1st</b> Check input sensors and output solenoid valves with <b>SST</b> (Refer to page 4A-12). <b>2nd</b> Check other switches with <b>SST</b> (Refer to page 4A-20). <b>3rd</b> Check the following items: <b>Electrical system</b> 1) Battery condition 2) Fuses <b>Fuel system</b> 1) Fuel level 2) Fuel leakage 3) Fuel filter 4) Idle speed (with test connector grounded) <b>Engine</b> 1) Compression 2) Overheating <b>Ignition system</b> 1) Spark plugs 2) Ignition timing <b>Intake air system</b> 1) Air cleaner element 2) Vacuum or air leakage 3) Vacuum hose routing 4) Accelerator cable <b>Others</b> 1) Clutch slippage 2) Brake dragging <b>4th</b> Check the Fuel and Emission Control Systems									
3	Engine stall										
	While warming up										
	After warming up										
4	Rough Idle										
	While warming up										
	After warming up										
5	High Idle speed after warming up										
6	Poor acceleration, hesitation, or lack of power										
7	Runs rough on deceleration										
8	Afterburn in exhaust system										
9	Poor fuel consumption										
10	Fail emission test										

83U04A-009



POSSIBLE CAUSE		Intake air system (Poor connection of components, throttle body)	Fuel system (Fuel injection, Fuel pressure)	ISC (Idle speed control) system (Air valve or Idle speed control malfunction)	PCV (Positive crank case ventilation) system (System clogged)	Deceleration control system (Fuel cut operation malfunction)	Evaporative emission control system	Exhaust system (System clogged)
PAGE		4A—25	4A—33	4A—29	4A—56	4A—47	4A—52	4A—71
SYMPTOM	2	2	1					
	3	3	2	1				
		4	3	2	1			
	4	4	3	1	2			
		5	4	2	1		3	
	5	2		1				
	6	2	3				1	4
	7		3	2		1		
	8	3	4	1		2		
	9		2			1		3
10	5	6	3		2	4	1	

83U04A-010

**Note**

The number of the list such shown a priorities of inspection from the most possible to that with the lowest possibility.

These were determined on following basis:

- Ease of inspection
- Most possible system
- Most possible point in system

## TROUBLESHOOTING WITH SST

### SELF-DIAGNOSIS CHECKER (49 H018 9A1)

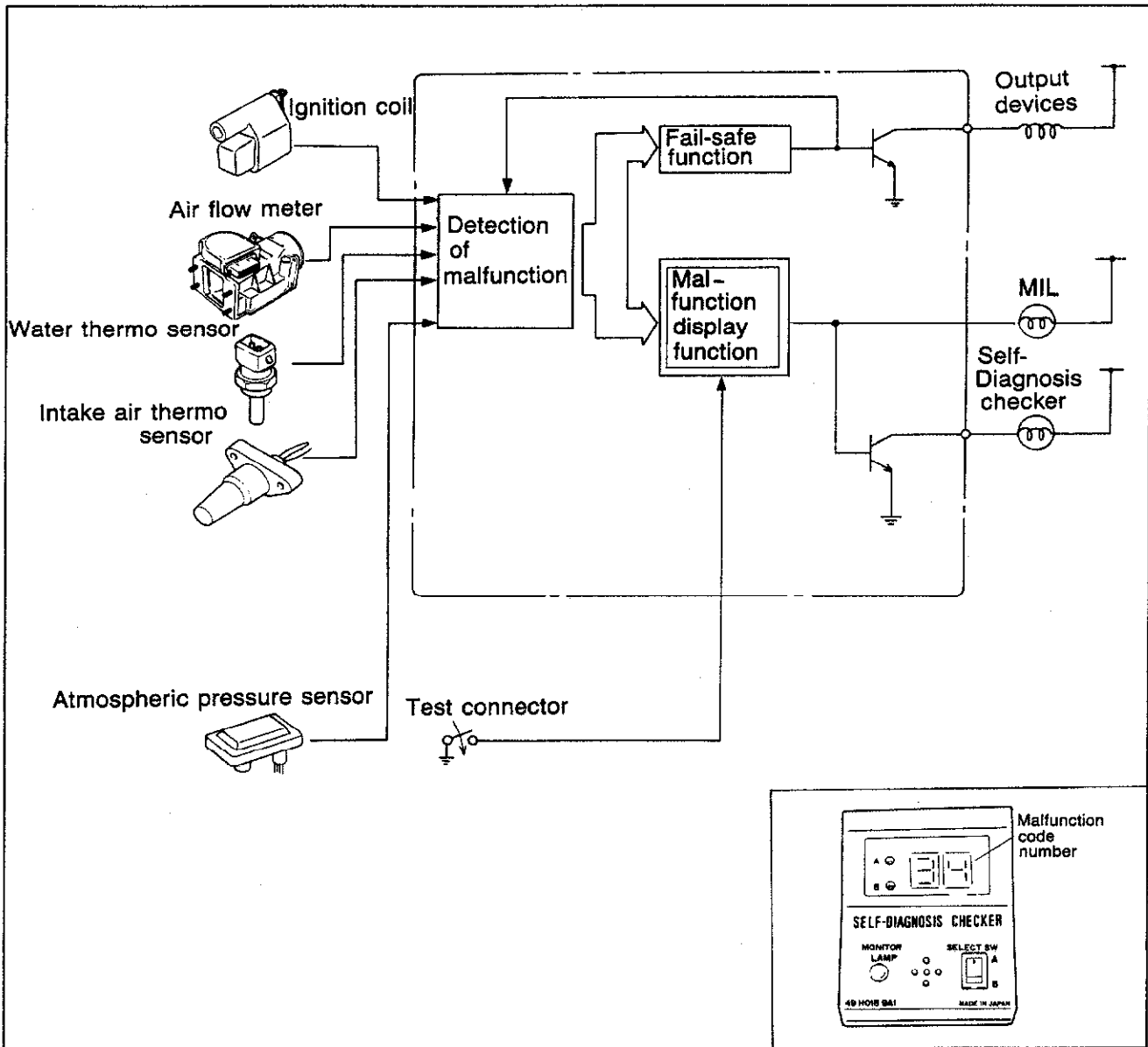

69G04A-020

When troubles occur in the main input devices or output devices, check for the cause using **SST**. Using the **SST**, failures of each input and output device are indicated and retrieved from the control unit as warning code numbers.

**Note**

**The control unit constantly checks for malfunction of the input devices. But, the control unit checks for malfunction of output devices only in a 3 second period after the ignition switch is turned ON and the test connector is grounded.**

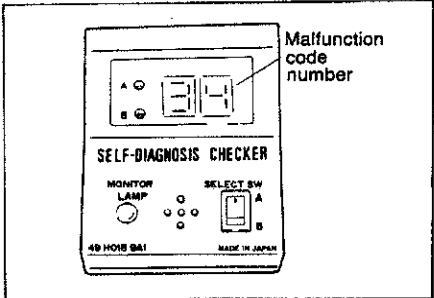

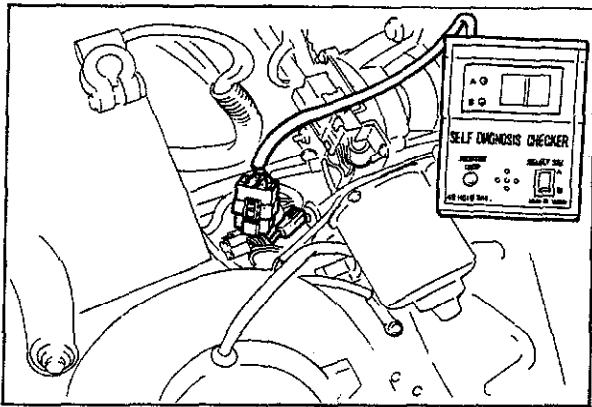

83U04A-200

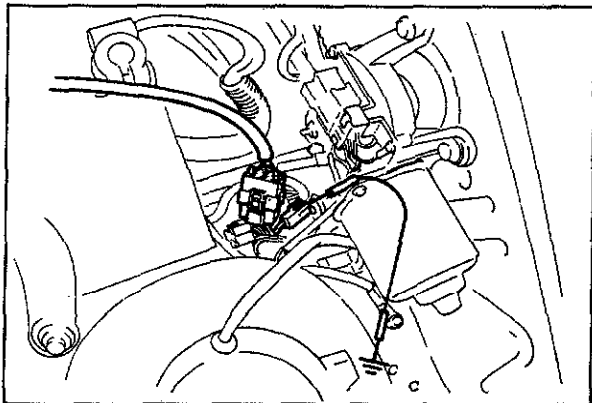

69G04C-123

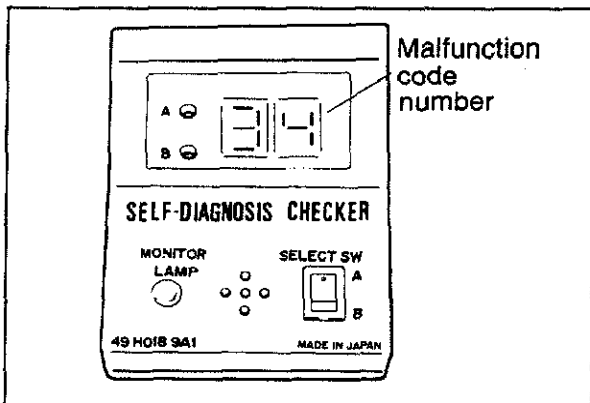

69G04A-023

## INSPECTION PROCEDURE

1. Warm-up the engine to normal operating temperature and stop it.
2. Connect **SST** to the check connector (Green: 6pin) and the battery negative terminal.

3. Connect a jumper wire between the test connector (Green: 1pin) and a ground.
4. Turn the ignition switch ON, then check for any code number.

### Note

The SST buzzer should sound for 3 sec. after the ignition switch is turned ON.

5. Start the engine, and check for further code numbers.
6. If a code number illuminates, check for the cause of the problem.

## TROUBLESHOOTING WITH MIL (MALFUNCTION INDICATOR LIGHT)

Refer to page 4A—73

### Note

The test connector (Green: 1 pin) must be grounded

# 4A TROUBLESHOOTING WITH SST

If a malfunction code number is illuminated on **SST**, check the following chart along with the wiring diagram.

## No. 01 Code illumination (Ignition Pulse)

PC: Possible Cause

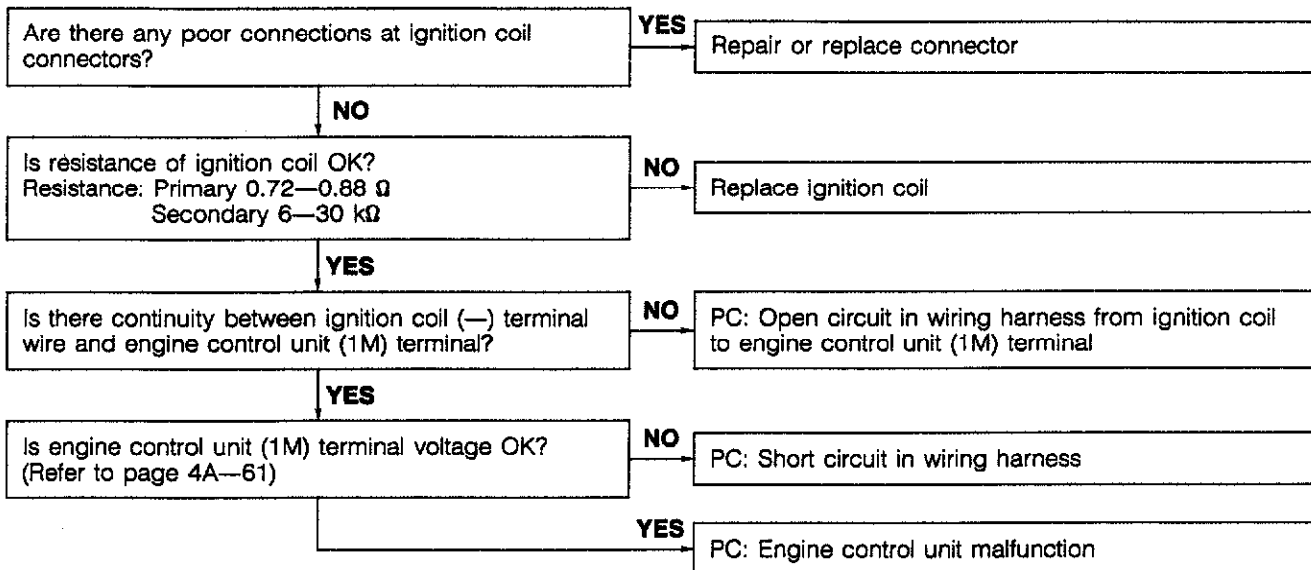

## No. 08 Code illumination (Airflow Meter)

83U04A-120

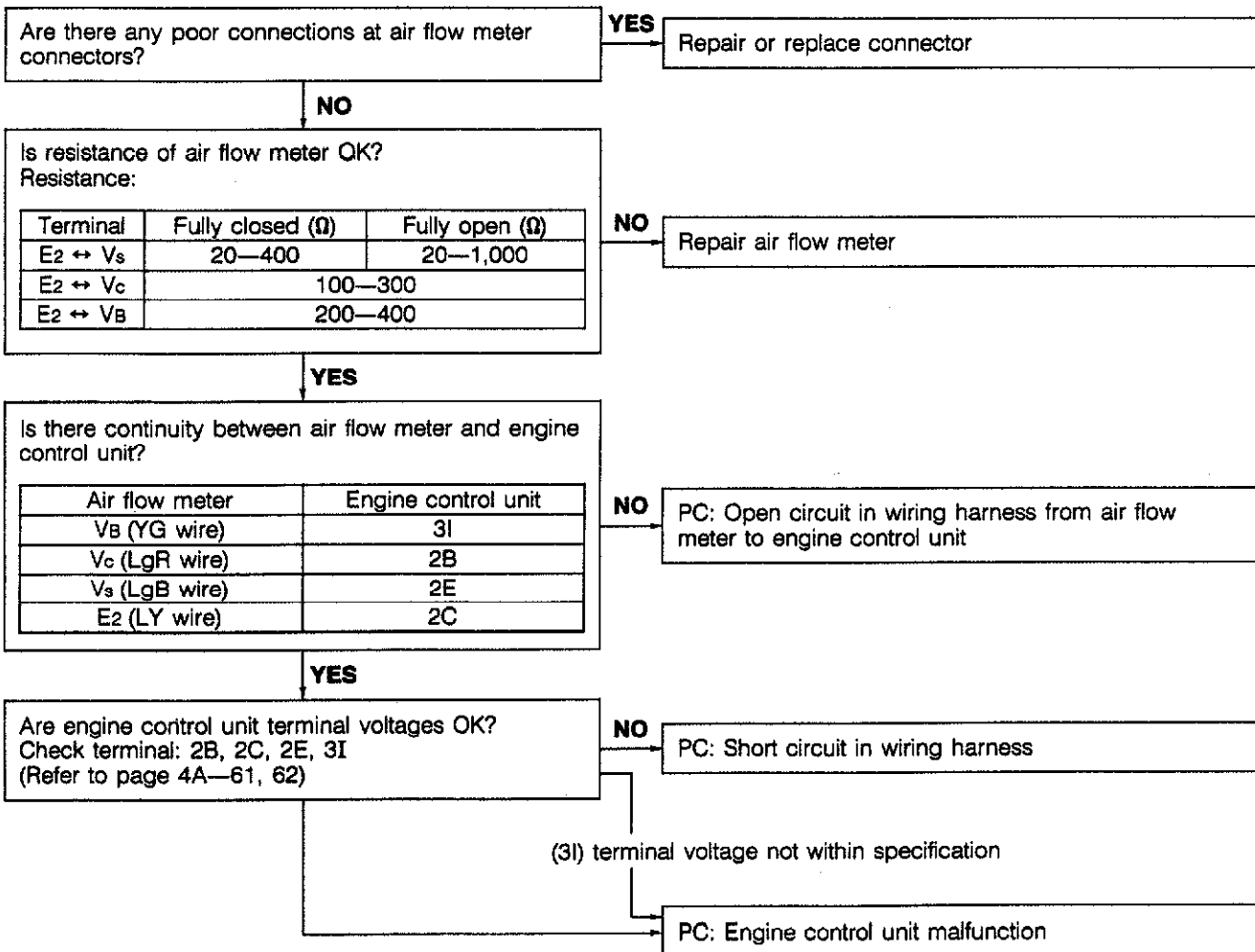

83U04A-011

**No. 09 Code illumination (Water Thermo Sensor)**

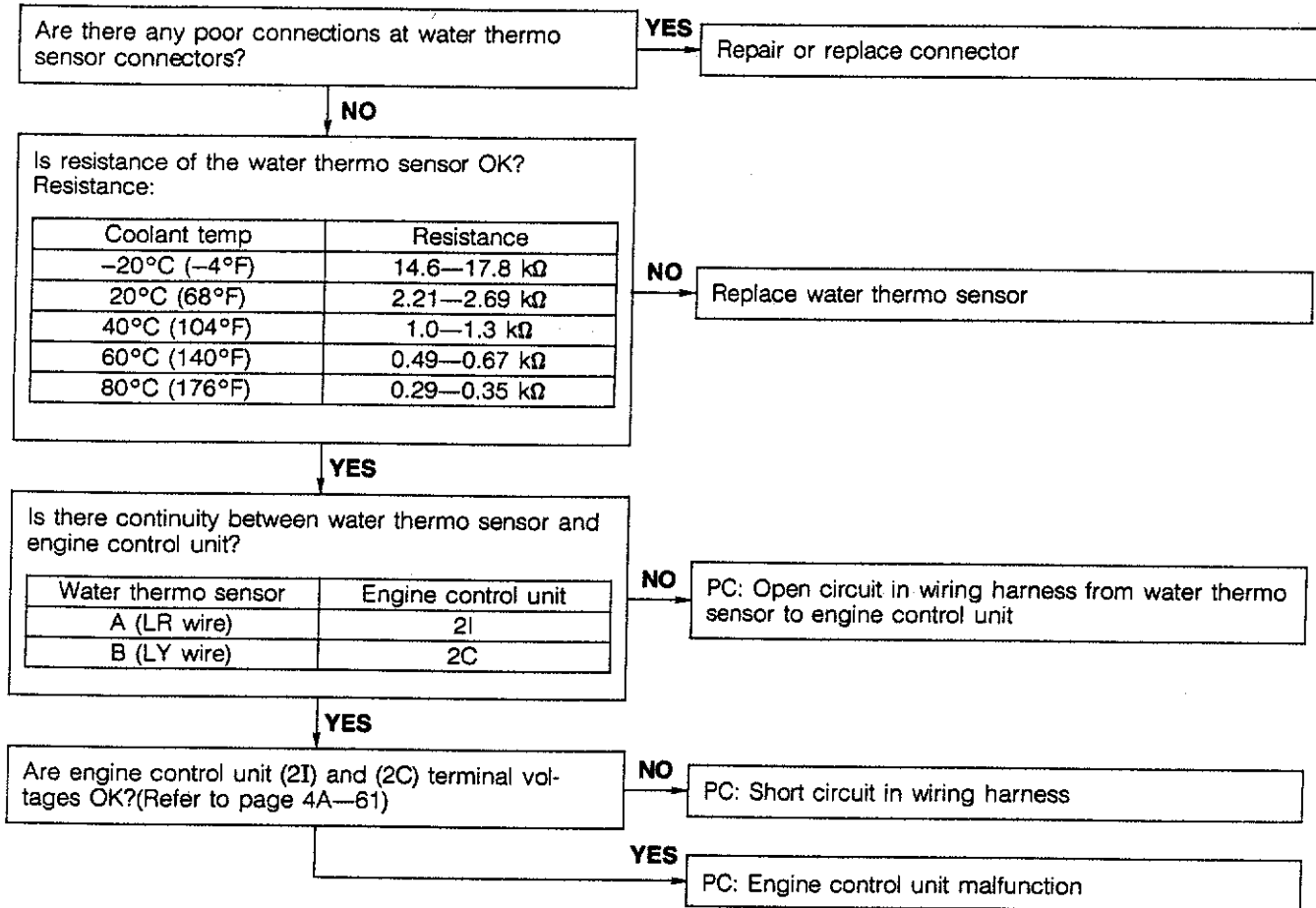

83U04A-012

## No. 10 Code illumination (Intake Air Thermo Sensor)

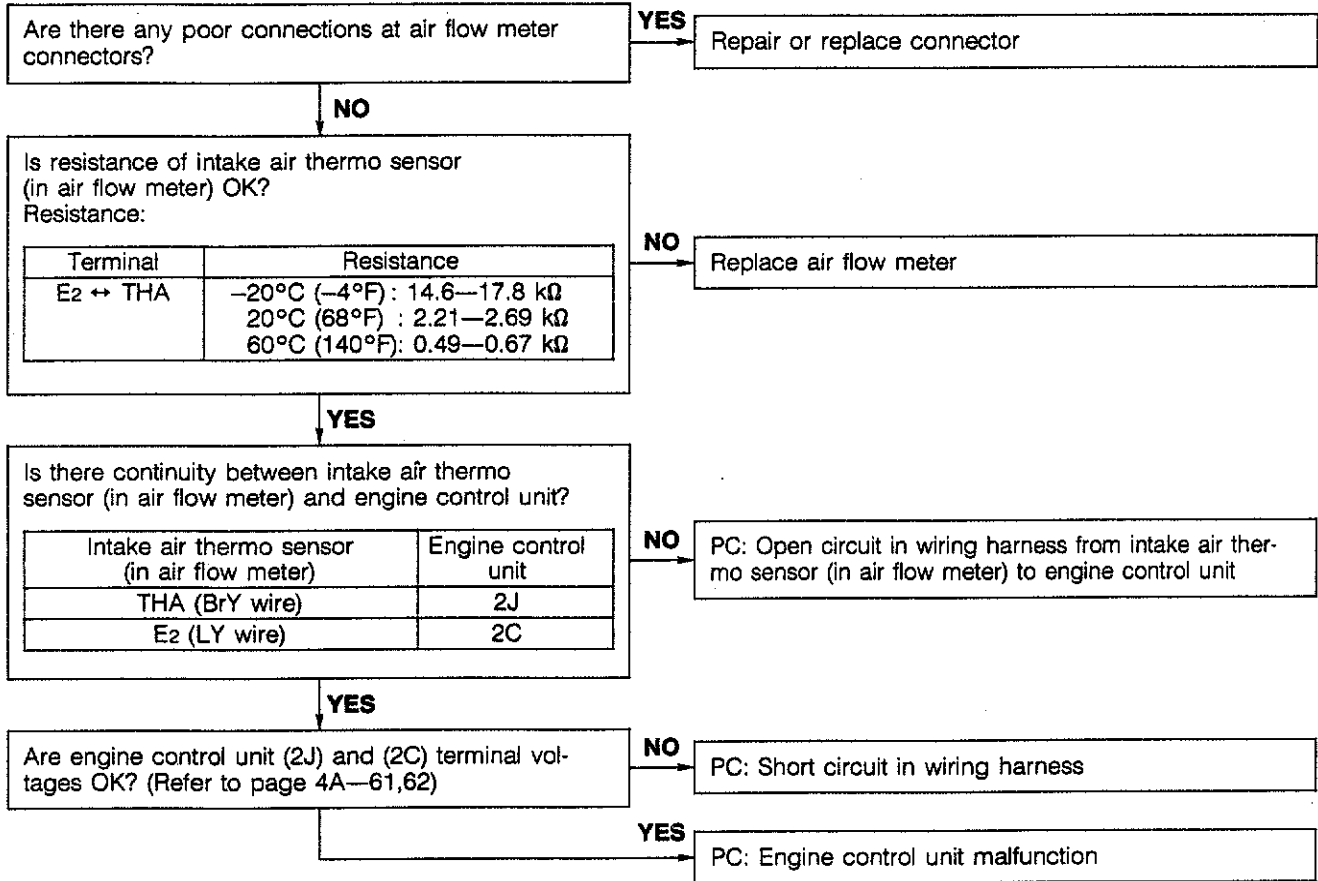

83U04A-013

## No. 14 Code illumination (Atmospheric Pressure Sensor)

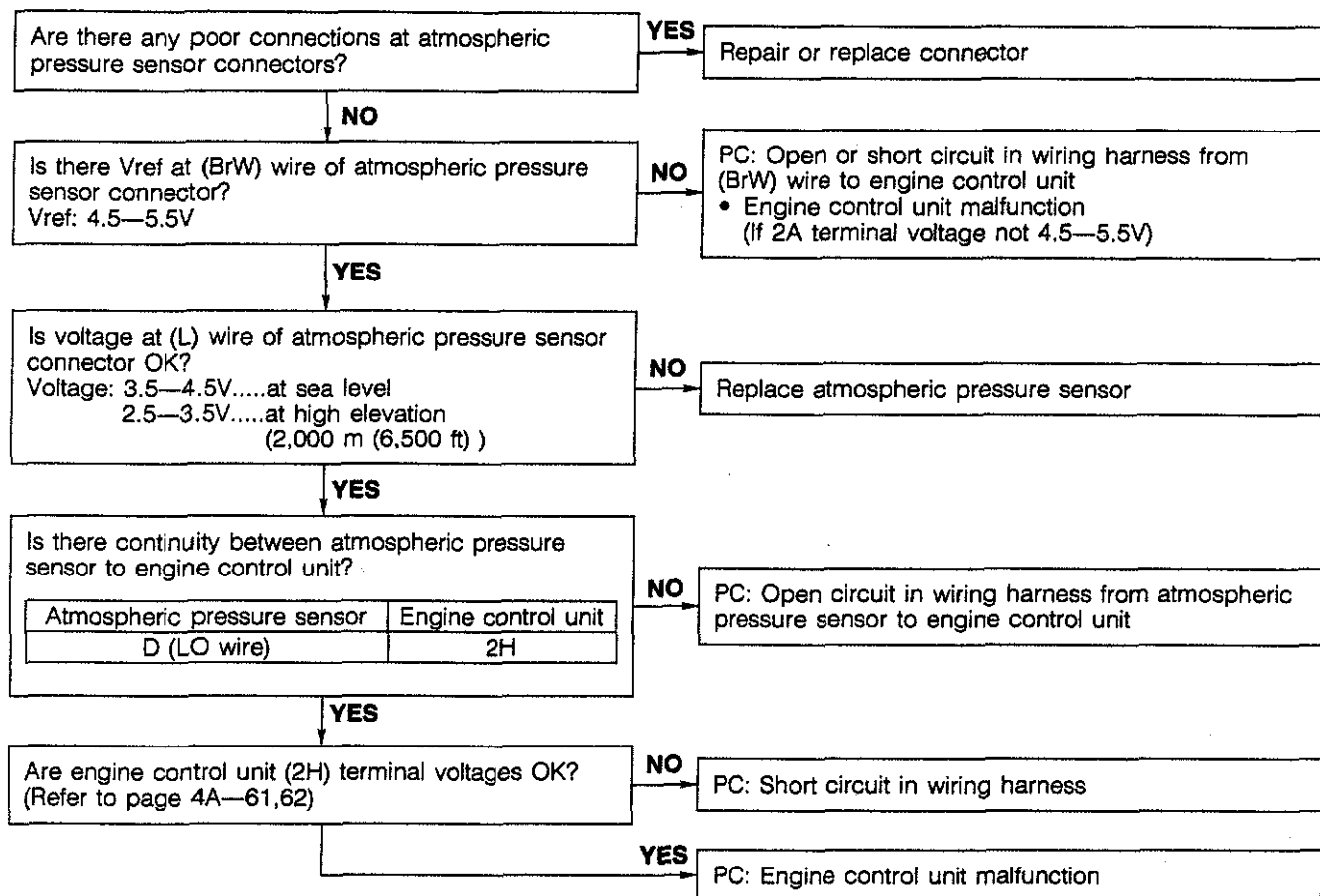

83U04A-014

## No. 15 Code illumination (Oxygen Sensor)

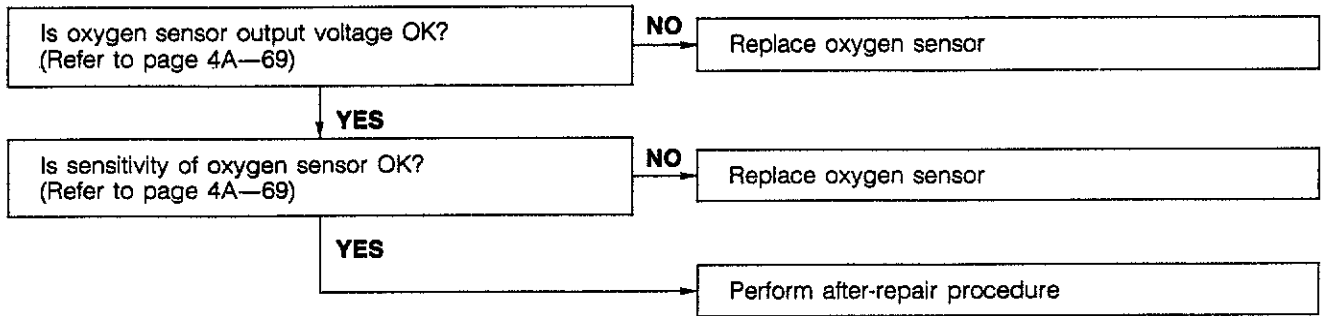

83U04A-015

## No. 17 Code illumination (Feedback System)

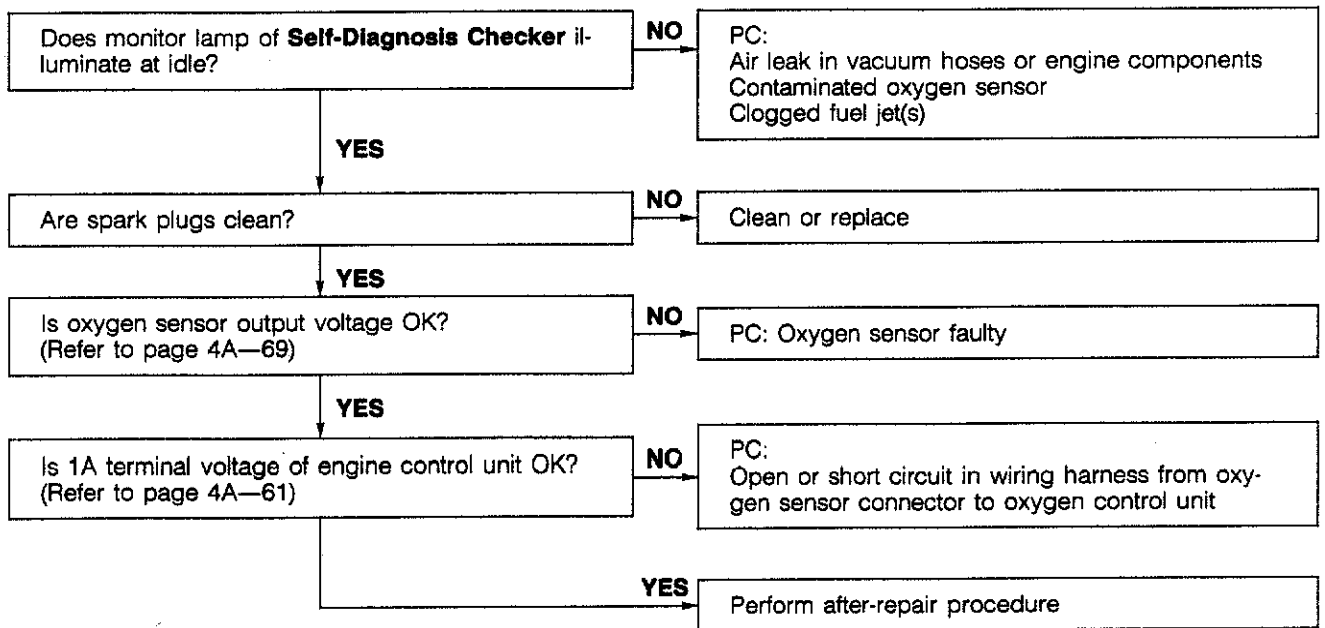

83U04A-016



## No. 26, 27 Code Illumination (Solenoid Valve)

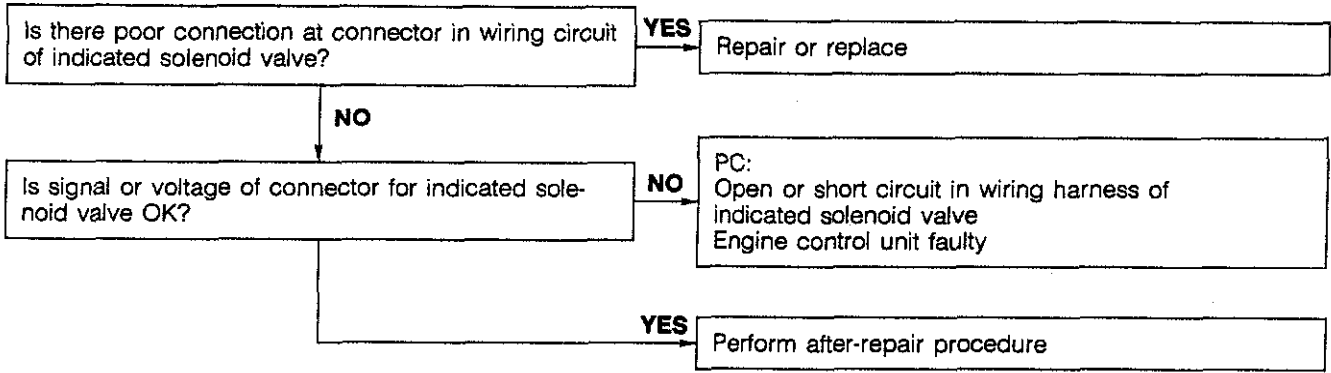

83U04A-017

## No. 34 Code Illumination (BAC valve)

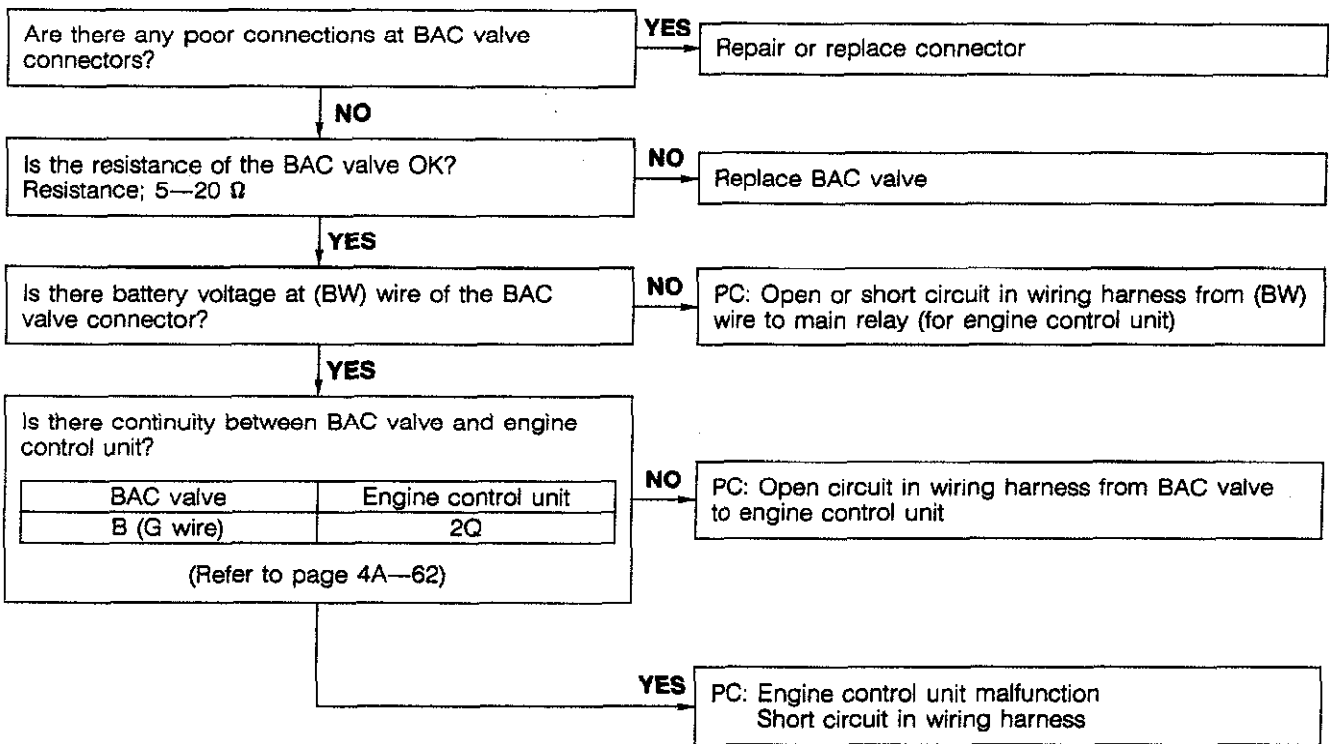

BAC valve	Engine control unit
B (G wire)	2Ω

(Refer to page 4A—62)

83U04A-018

# 4A MONITOR SWITCH FUNCTION

## MONITOR SWITCH FUNCTION

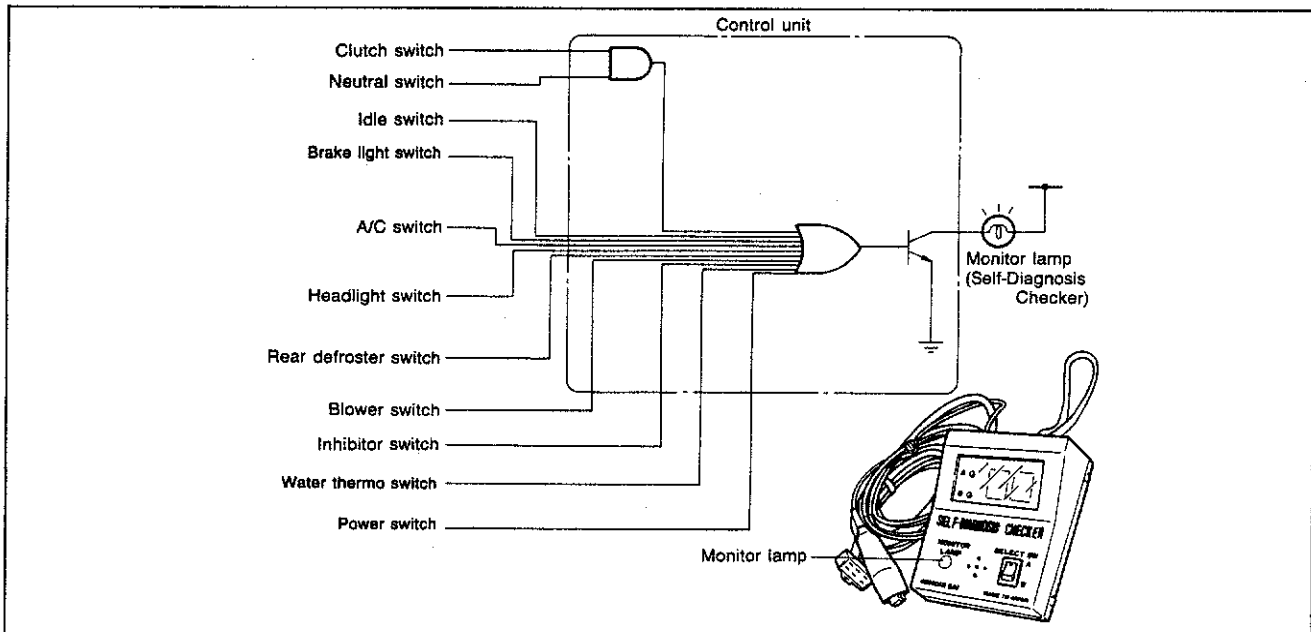

83U04A-019

The operation of individual switches can be determined by the monitor lamp **SST**.

### Note

The test connector must be grounded and the ignition switch **ON** (engine stopped) to check the switches.

Switch	Self-Diagnosis Checker		Remarks
	Light ON	Light OFF	
Clutch switch	Pedal released	Pedal depressed	Gear: IN
Neutral switch (Throttle sensor)	In gear	Neutral	Clutch pedal released
Idle switch	Pedal depressed	Pedal released	
Brake light switch	Pedal depressed	Pedal released	
A/C switch	ON	OFF	Blower motor position: "1" position
Headlight switch	ON	OFF	
Rear defroster switch	ON	OFF	
Blower switch	ON	OFF	Blower motor position: "3" position
Inhibitor switch	D, 1, 2 and R range	P and N range	
Water thermo switch (Electric fan)	Disconnected terminal	Connected terminal	
Power switch	Pedal depressed	Pedal fully depressed	

## OXYGEN SENSOR MONITOR FUNCTION

The oxygen sensor and feedback mode are monitored as follows.

Condition		Item monitored	Function
Engine	Test connector		
Running	Not grounded	Oxygen sensor output signal	Oxygen sensor output more than 0.55V: Monitor lamp ON
		Oxygen sensor output signal	Oxygen sensor output less than 0.55V: Monitor lamp OFF

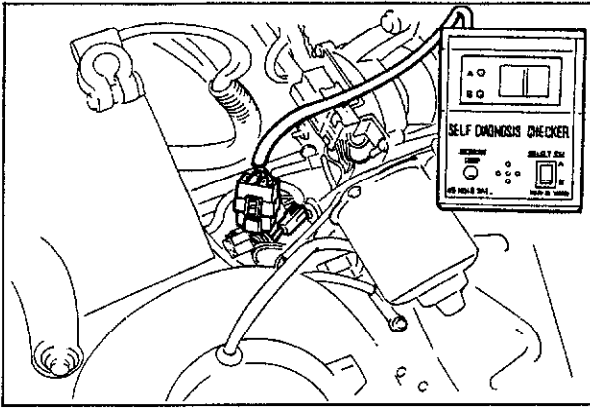

69G04A-037

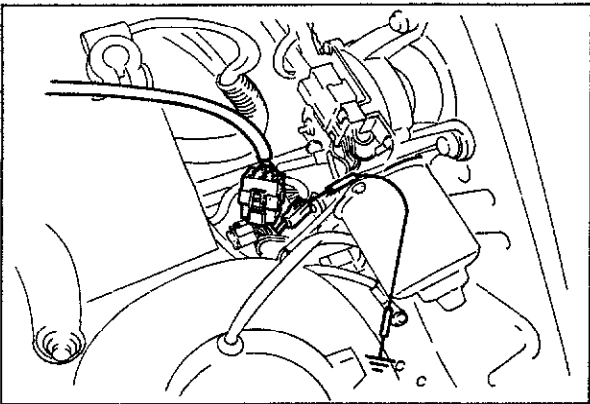

69G04C-030

## INSPECTION PROCEDURE

1. Warm up the engine to normal operating temperature and stop it.
2. Connect **SST** to the check connector (Green: 6pin) and the negative battery terminal.

3. Connect a jumper wire between the test connector (Green: 1 pin) and a ground.
4. Turn the ignition switch ON, then check that the monitor lamp illuminates when each switch is made to function according to below procedure.

### Caution

- a) If even one of the switches is activated, the monitor lamp will stay on.
- b) Do not start the engine.

## Procedure

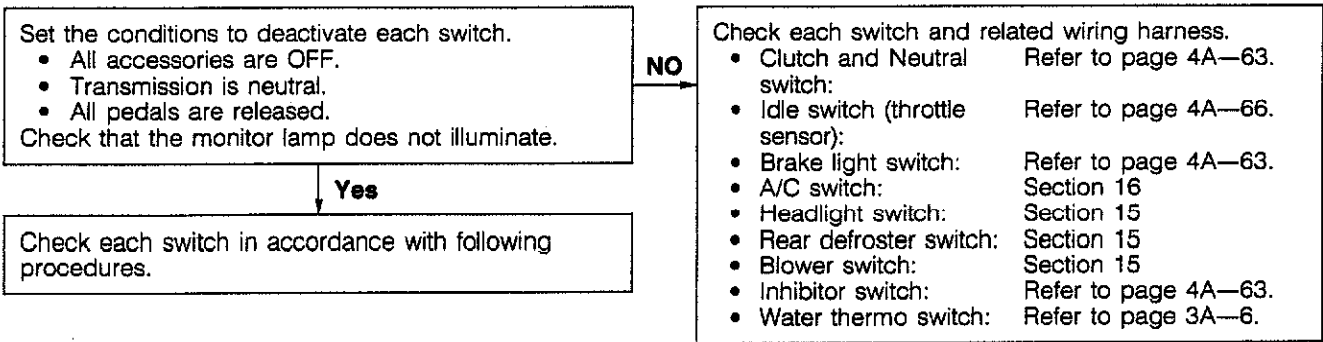

83U04A-020

## Neutral and clutch switch (MTX)

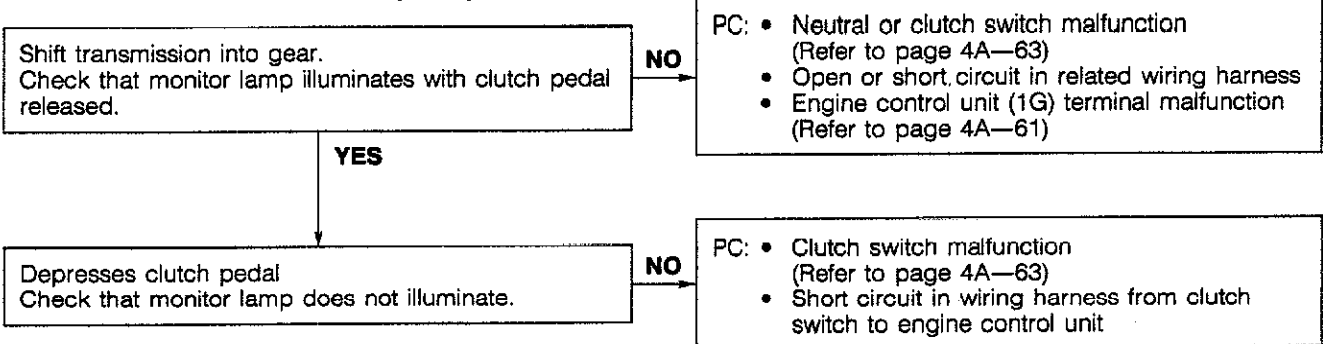

83U04A-021

# 4A MONITOR SWITCH FUNCTION

## Idle switch and power switch (Throttle sensor)

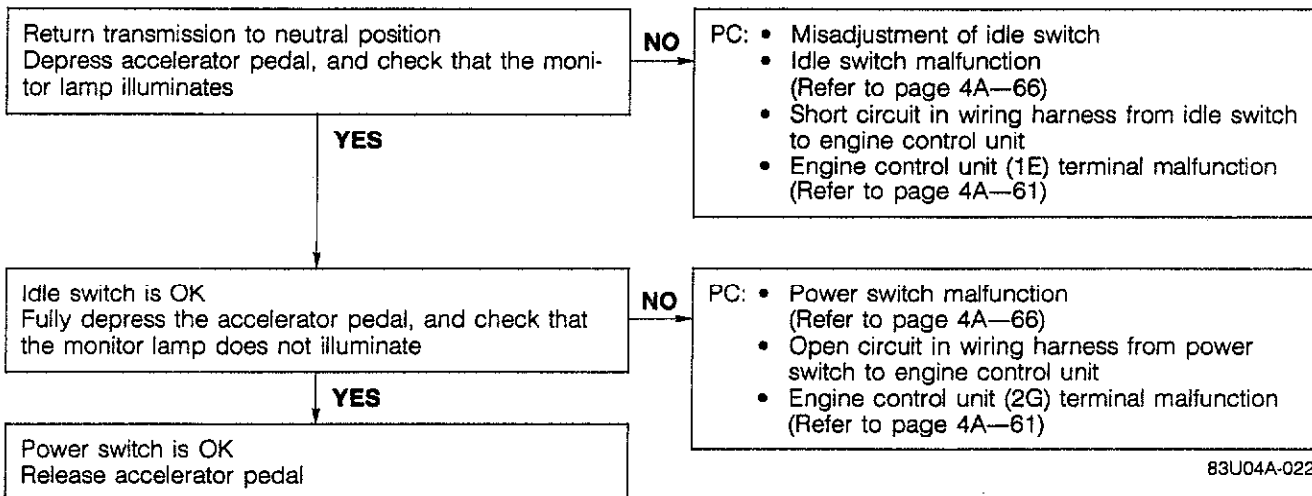

## Brake light switch

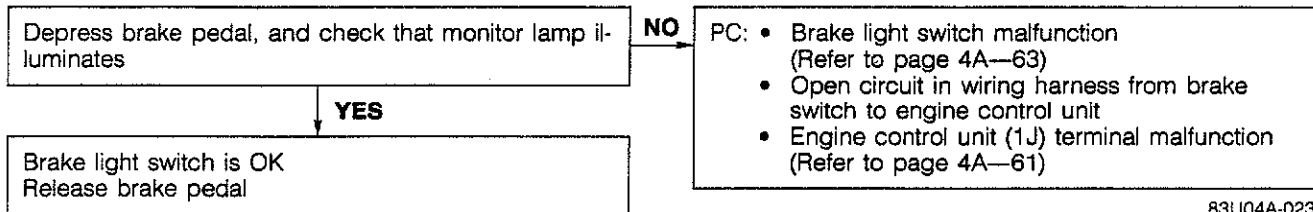

## Blower switch

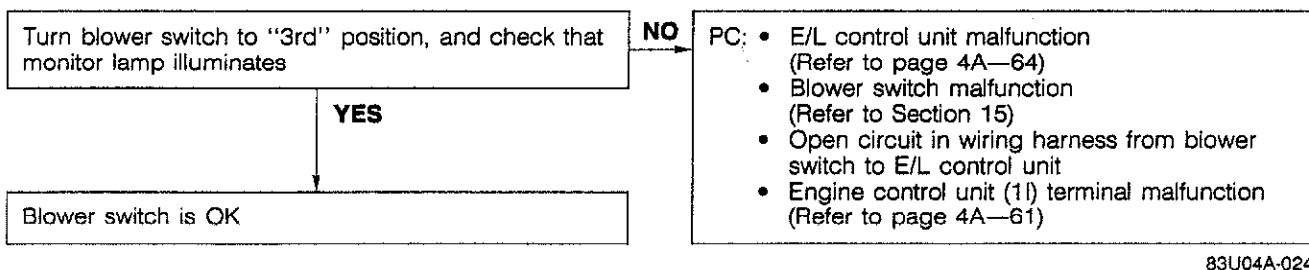

## A/C switch

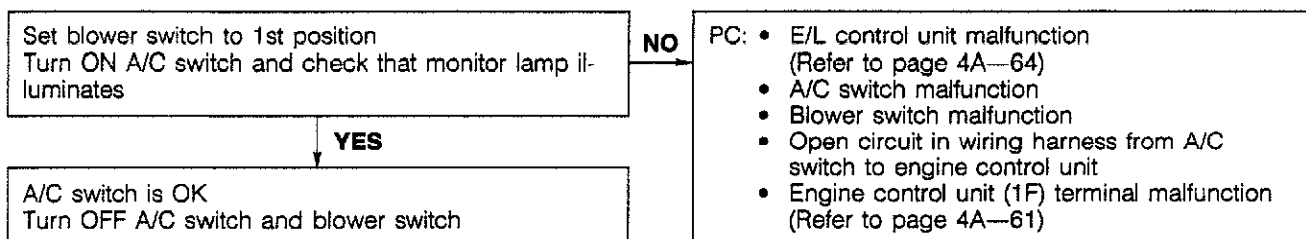

## Headlight switch

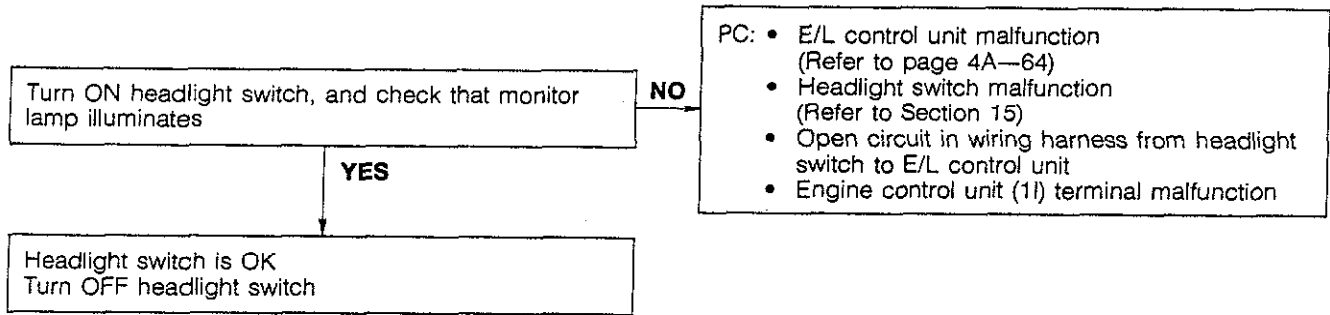

83U04A-026

## Rear defroster switch

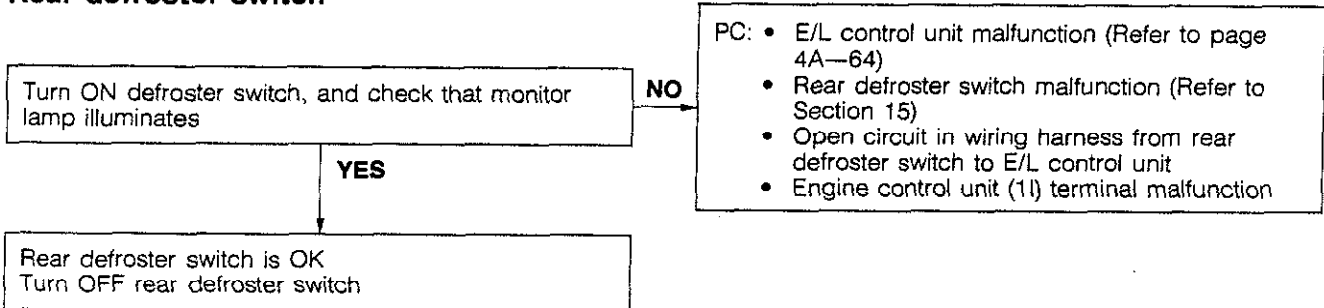

83U04A-027

## Inhibitor switch

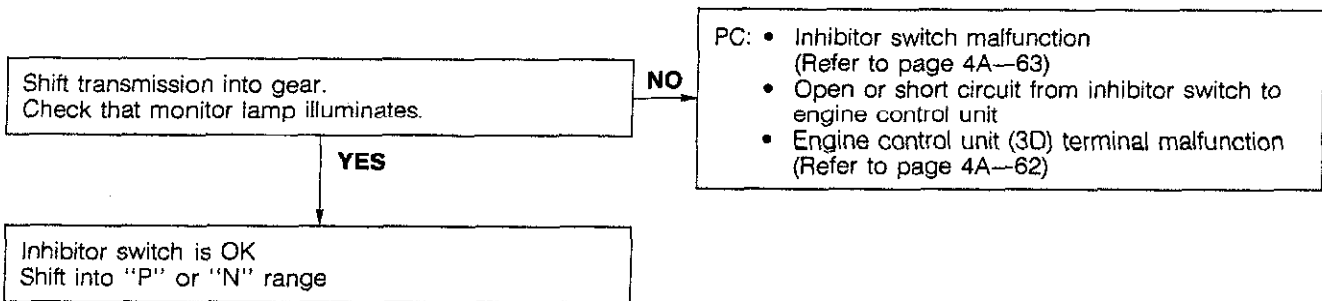

83U04A-028

## Water thermo switch circuit (not include switch inspection)

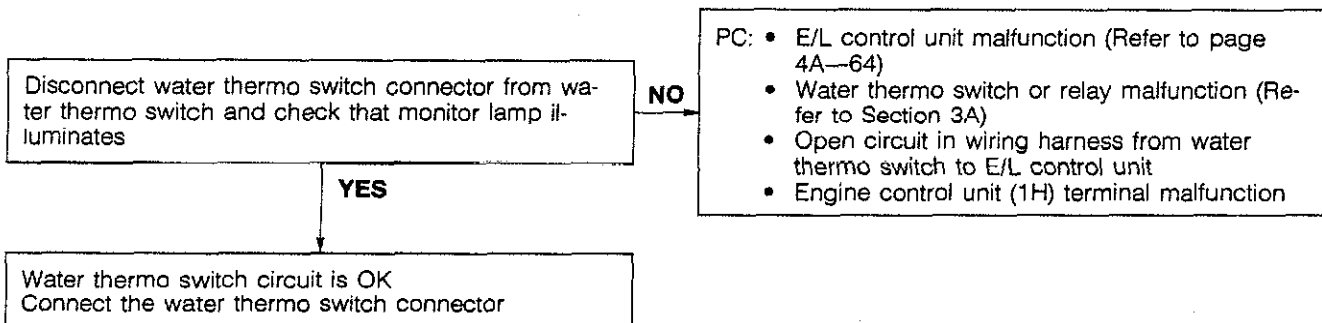

83U04A-029

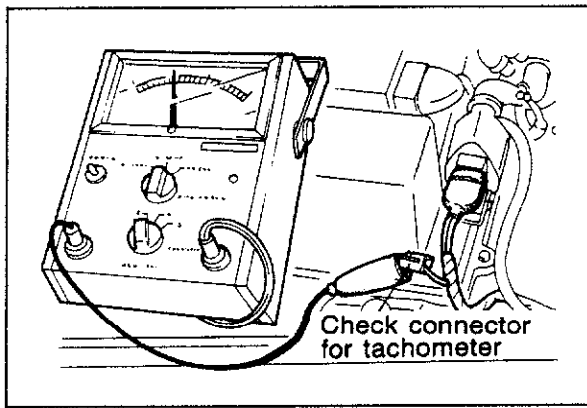

83U04A-030

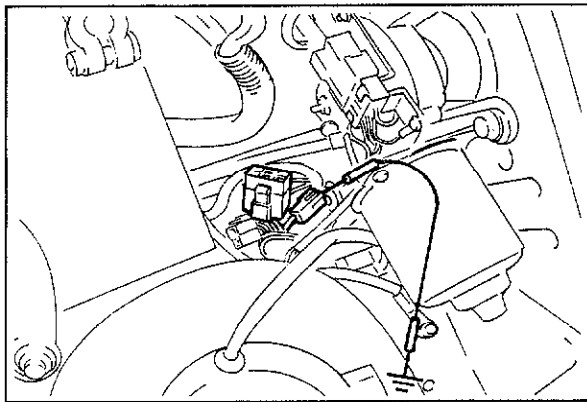

83U04A-031

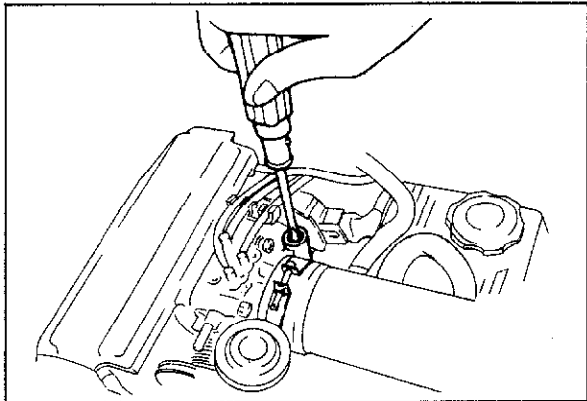

83U04A-032

## IDLE ADJUSTMENT

### Preparation

Before checking or adjusting the idle speed, perform the followings:

- Switch off all accessories.
- Connect a tachometer to check connector. (White 1 pin)
- Warm up the engine to normal operating temperature.
- Check and adjust the ignition timing.

- Connect a jump wire between the test connector (Green: 1 pin) and ground.

### Idle speed

1. Check the idle speed.

**Idle speed: 850 ± 50 rpm (MTX: Neutral)  
(ATX: in "P" range)**

2. If the idle speed is not within specification, remove the blind cap from air adjust screw and adjust it by turning the air adjust screw.
3. After adjusting the idle speed, install the blind cap and disconnect a jumper wire from test connector.

### Note

**Check and adjust the dashpot operation after adjusting the idle speed.**

INTAKE AIR SYSTEM

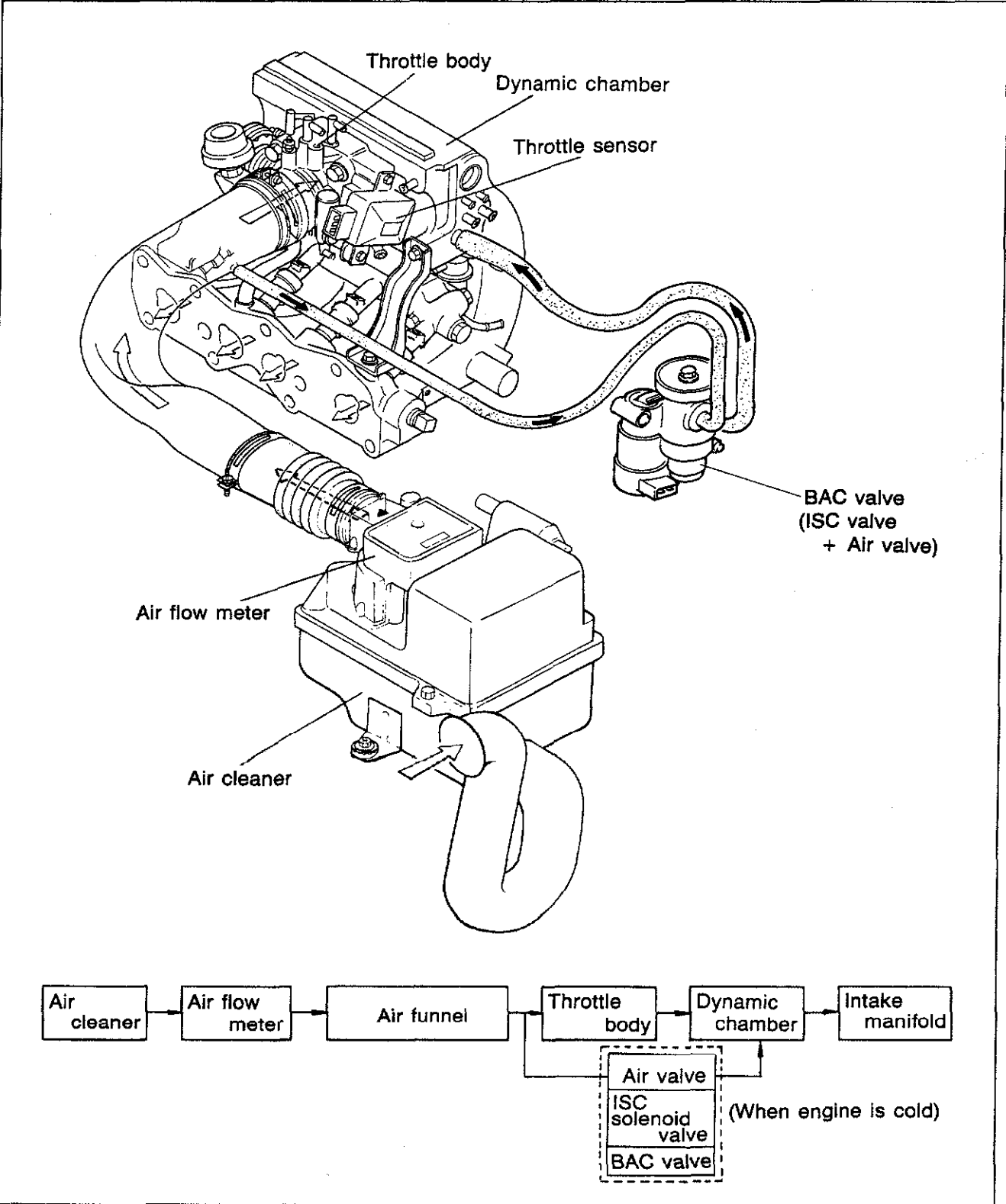

83U04A-114

The intake air system supplies air required by the engine for the formation of the air-fuel mixture and measures the air flow and air temperature. It consists of the air cleaner, air flow meter, throttle body, dynamic chamber and BAC valve.

# 4A INTAKE AIR SYSTEM

## REMOVAL AND INSTALLATION

1. Disconnect the battery negative cable.
2. Disassemble the intake air system in the sequence shown in the figure.
3. Install in the reverse order of removal.

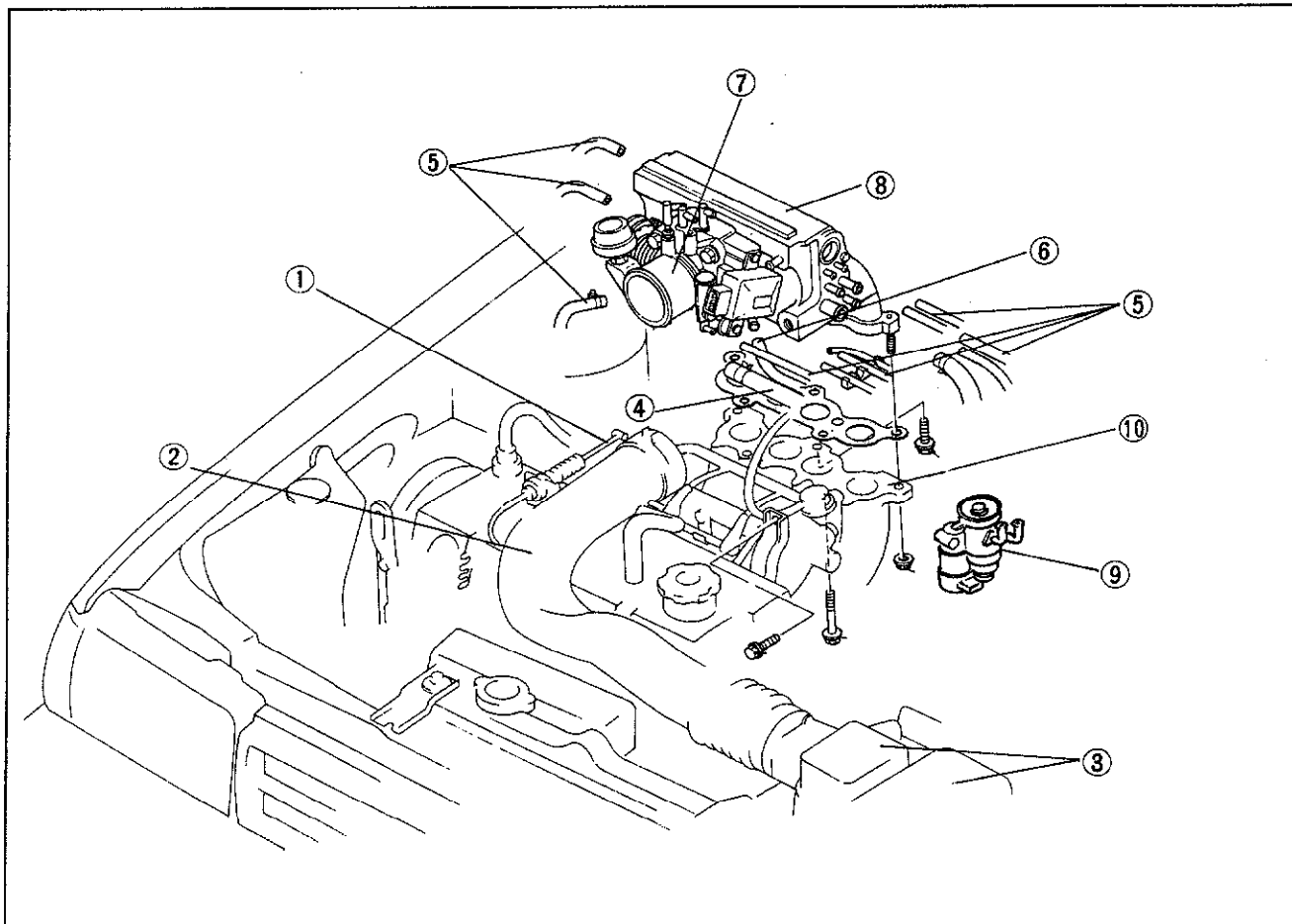

83U04A-033

- |                                      |                     |
|--------------------------------------|---------------------|
| 1. Accelerator cable                 | 6. Water hoses      |
| 2. Air funnel                        | 7. Throttle body    |
| 3. Air cleaner (with Air flow meter) | 8. Dynamic chamber  |
| 4. Air hoses                         | 9. BAC valve        |
| 5. Vacuum hoses                      | 10. Intake manifold |



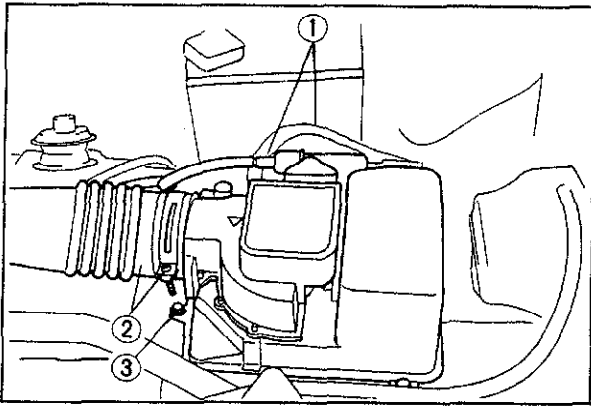

83U04A-034

## Air Flow Meter Removal and Installation

1. Remove the high tension lead and ignition coil connectors.
2. Loosen the hose band and remove the intake air hose.
3. Remove the attaching bolts.

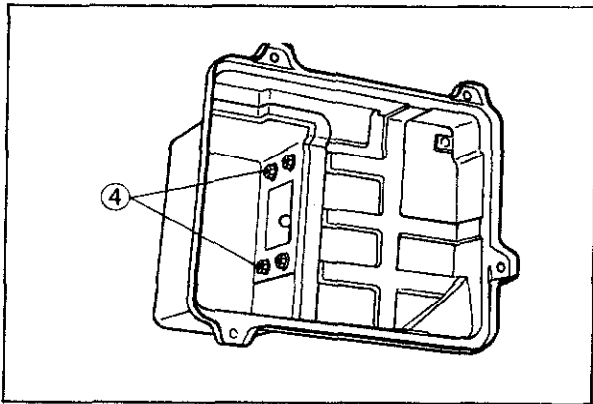

73U04B-041

4. Turn the air cleaner cover upside down and remove the attaching nuts.
5. Remove the air flow meter.

Install in the reverse order of removal.

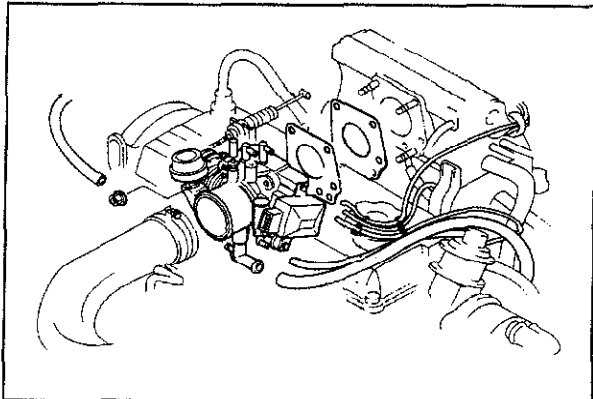

83U04A-035

## Throttle Body Removal and Installation

1. Drain the water from radiator
2. Disconnect the accelerator cable from the throttle linkage
3. Disconnect the air funnel
4. Disconnect the hoses and tubes
5. Disconnect the throttle sensor connector
6. Remove the attaching nuts and bolts of throttle body
7. Remove the throttle body
8. Install in the reverse order of removal

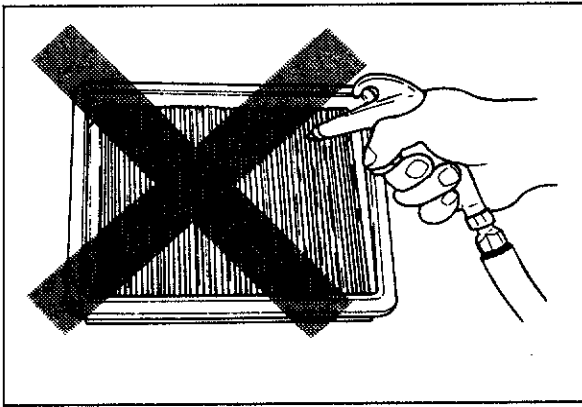

69G04A-059

## PARTS INSPECTION Air Cleaner Element

### Caution

**Do not use the compressed air to clean the air cleaner element.**

1. Check the condition of the air cleaner element.
2. Replace, if necessary.

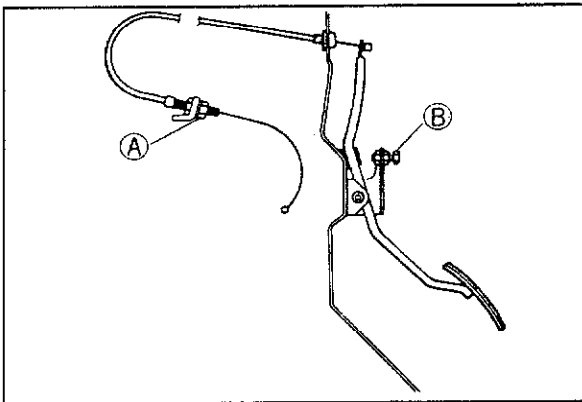

69G04A-060

## Accelerator Cable

1. Inspect the deflection of the cable. If the deflection is not within **1 ~ 3 mm (0.04 ~ 0.12 in.)**, adjust by using nuts (A).
2. Depress the accelerator pedal to the floor and confirm that the throttle valve is fully opened. Adjust by using bolt (B) if necessary.

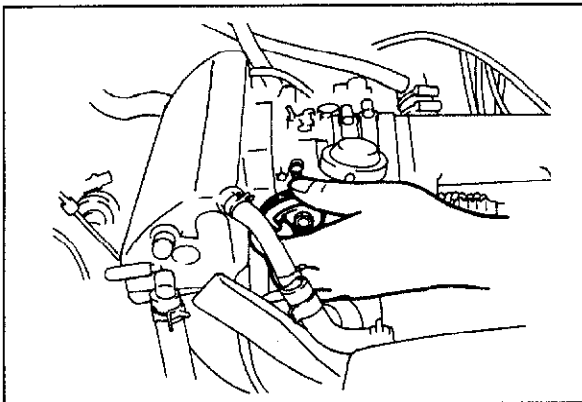

83U04A-036

## Throttle Body

1. Check that the throttle valve move smoothly when throttle lever is moved from fully closed to fully open.
2. Replace, if necessary.

### Note

**For inspection and adjustment of throttle sensor, refer to Control System (Page 4A-66).**

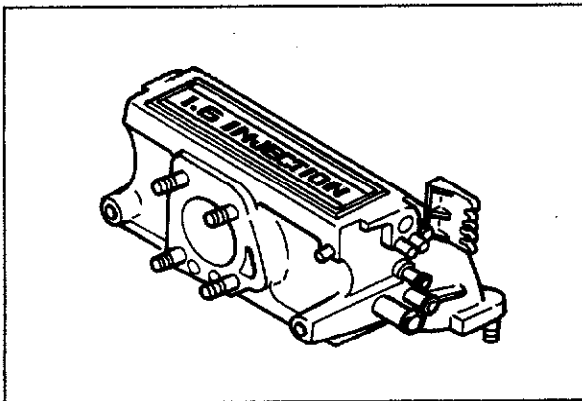

83U04A-037

## Dynamic Chamber

1. Visually check the dynamic chamber for damage.
2. Replace, if necessary.

**IDLE SPEED CONTROL (ISC) SYSTEM**

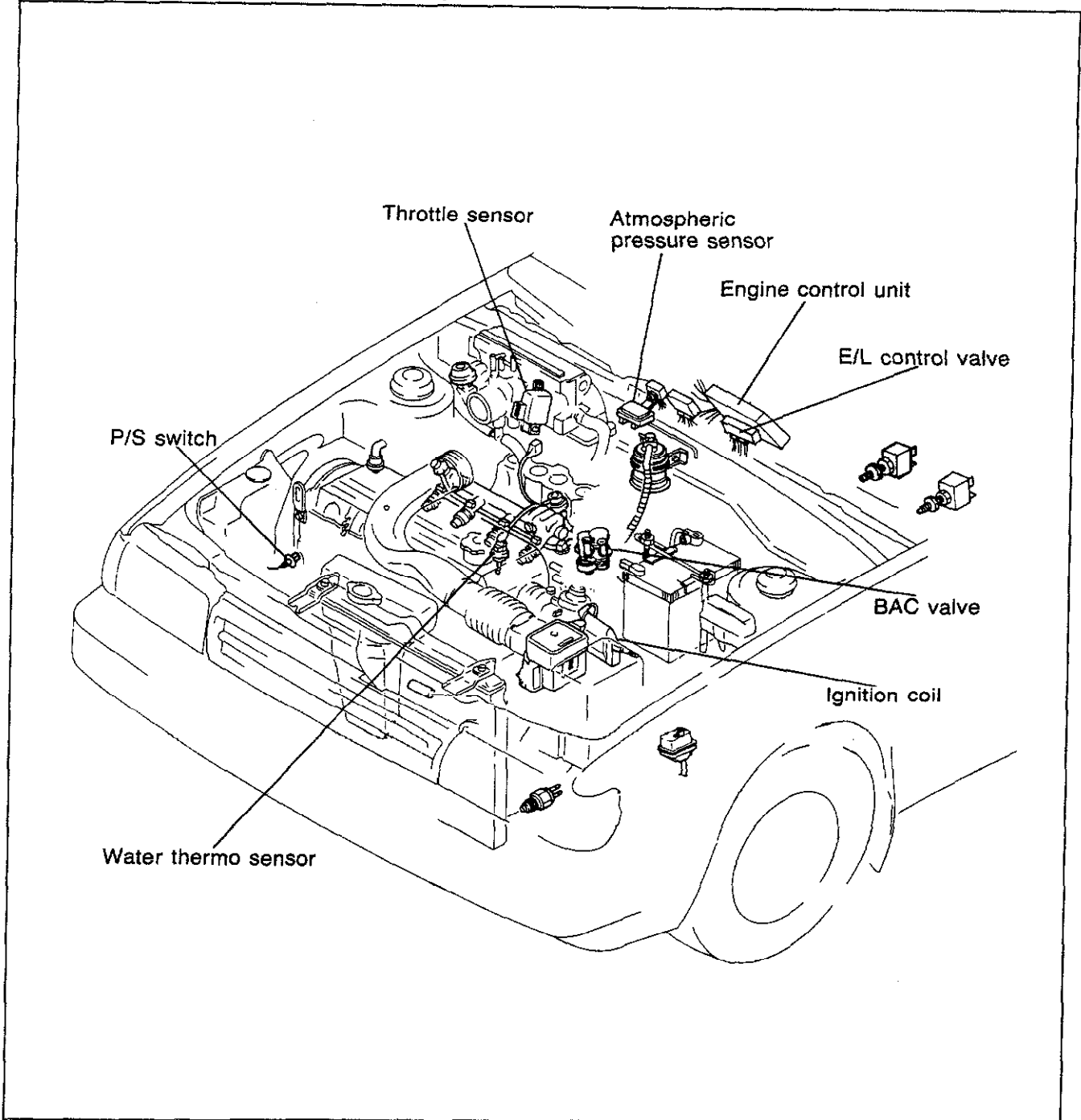

83U04A-038

**OUTLINE**

To improve idle smoothness, the ISC system controls the intake air amount detected by the air flow meter by regulating the bypass air amount that passes through the throttle body, and thereby helps the engine to maintain a steady idle speed.

This system consists of the BAC valve and the control system.

The BAC valve consists of the air valve which functions only during cold engine conditions and the ISC valve which works throughout the entire engine speed range.

# 4A IDLE SPEED CONTROL (ISC) SYSTEM

## TROUBLESHOOTING CHART

Before performing the following troubleshooting, check the condition of the wiring harness and connector.

POSSIBLE CAUSE		Water thermo sensor	Intake air thermo sensor	Throttle sensor (Variable resistor type)	ISC system (System inspection)	BAC valve	Engine control unit terminal voltage
							2Q
SYMPTOM		4A-68	4A-68	4A-66	4A-31	4A-32	4A-62
Engine stall	While warming up	3	4		1	2	5
	After warming up	3	4		1	2	5
Rough Idle	While warming up	3	4		1	2	5
	After warming up	3	4		1	2	5
High idle speed after warming up		3	4		1	2	5
Runs rough on deceleration		4	5	3	1	2	6
Afterburn in exhaust system		4	5	3	1	2	6
Poor acceleration, hesitation, or lack of power		4		3	1	2	5
Fail emission test		4	5	3	1	2	6

83U04A-039

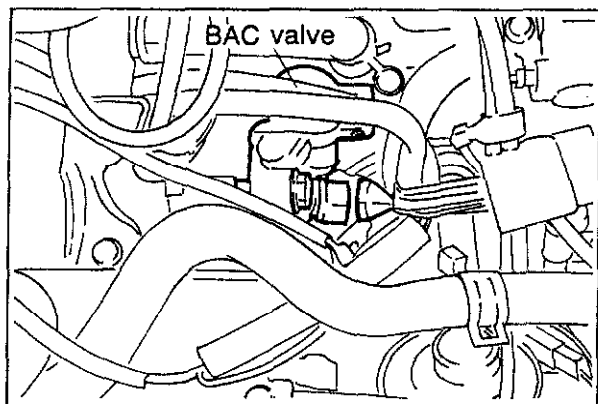

83U04A-040

### System Inspection

1. Connect the jumper wire between the test connector (Green: 1 pin) and ground. (Refer to page 4A-13).
2. Disconnect the BAC valve connector.

### Note

**When the BAC valve is disconnected, the engine speed will be reduced, which is normal.**

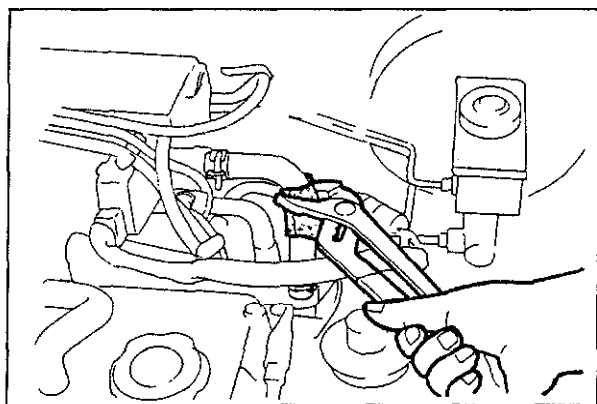

83U04A-041

3. Start the engine and run it at idle.
4. Pinch the air hose and note the engine speed.

**Cold engine: Engine speed drops**

**Warm engine: Engine speed unchanged**

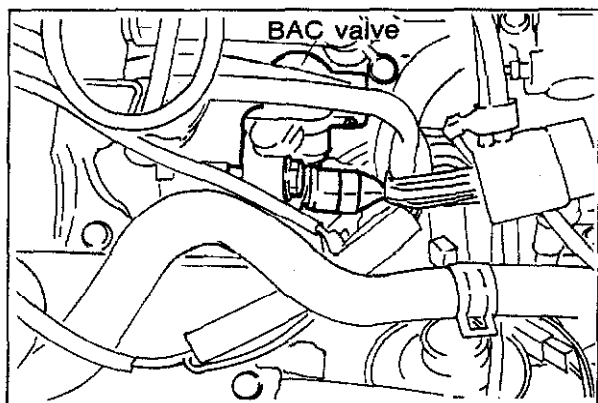

83U04A-042

5. Connect the BAC valve connector.
6. Disconnect the test connector.
7. Warm up the engine to normal operating temperature and run it at idle.
8. Check that the idle speed is correct.

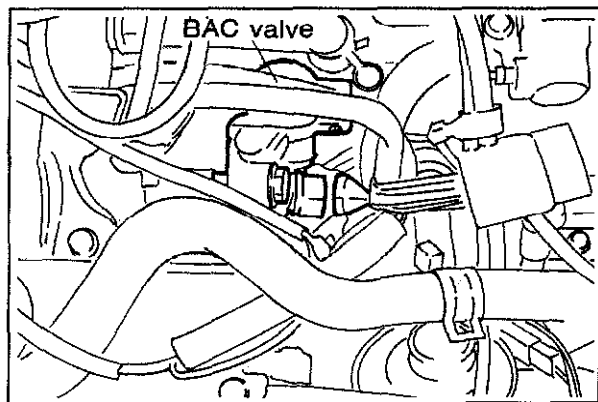

83U04A-043

9. Connect the jumper wire between the test connector and ground.
10. Disconnect the BAC valve connector.
11. Check that the engine speed decreases.
12. Reconnect the BAC valve connector.
13. Disconnect the jumper wire.

# 4A IDLE SPEED CONTROL (ISC) SYSTEM

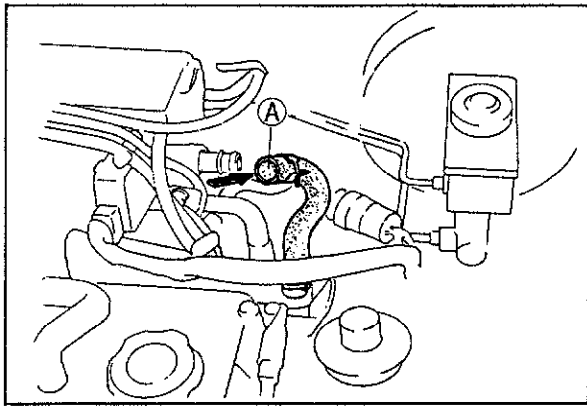

83U04A-044

## BAC Valve

### Air valve

1. Disconnect the air hoses from the air funnel.
2. Blow through the BAC valve from port (A). Check the air flow.

**Cold engine: Air flows**

**Warm engine: Air does not flow**

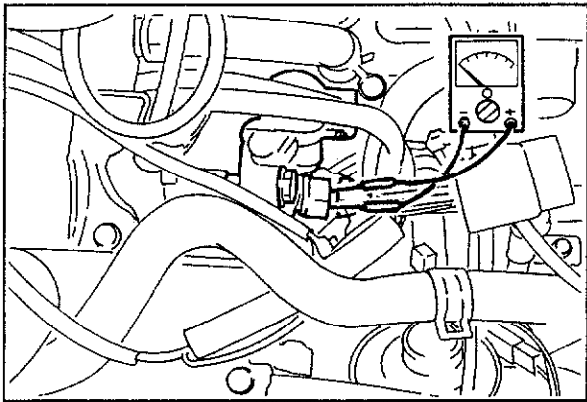

83U04A-045

## ISC valve

1. Disconnect the BAC valve connector.
2. Connect an ohmmeter to the terminals of the BAC valve.
3. Check the resistance.

**Resistance: 5—20  $\Omega$**

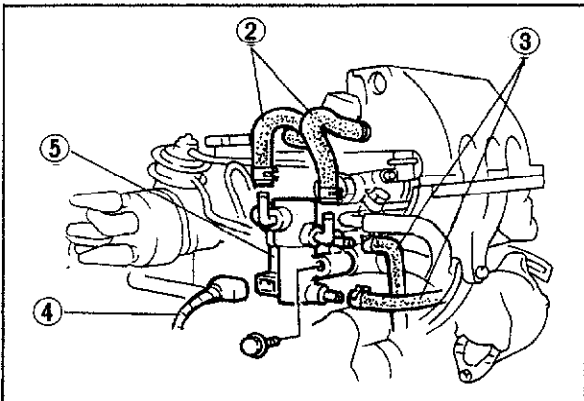

83U04A-046

## Removal and Installation

1. Drain the water from radiator.
2. Disconnect the by-pass air hoses.
3. Disconnect water hoses.
4. Disconnect the BAC connector.
5. Remove the BAC valve.
6. Install in the reverse order of removal.

FUEL SYSTEM

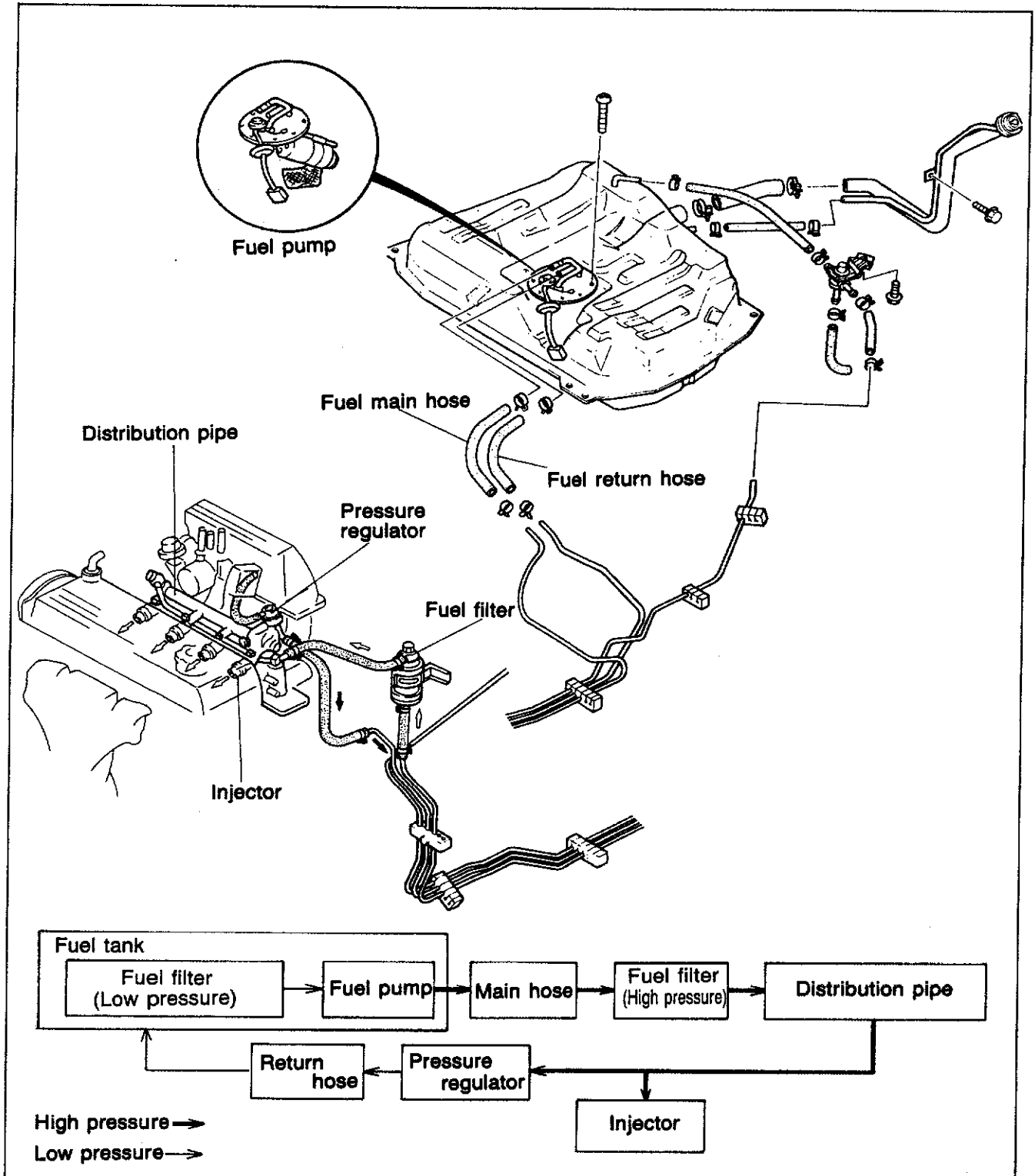

63U04B-514

The fuel system supplies the injectors with fuel necessary for combustion at a constant pressure. Fuel is metered and injected into the intake manifold and intake ports according to the injection signals from the engine control unit.

The system consists of the fuel pump, fuel filter, distribution pipe, pressure regulator and the injectors.

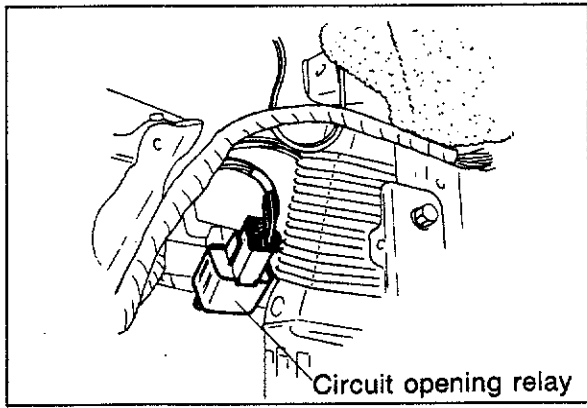

83U04A-047

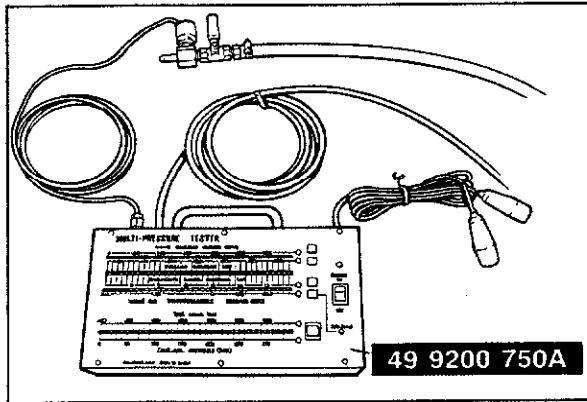

69G04A-098

## FUEL PRESSURE RELEASE AND SERVICING FUEL SYSTEM

Fuel in the fuel lines remains under high pressure even when the engine is not running.

- a) Before disconnecting any fuel line, release the fuel pressure from the fuel line to reduce the possibility of injury or fire.
  1. Start the engine.
  2. Disconnect the circuit opening relay connector.
  3. After the engine stalls, turn OFF the ignition switch.
  4. Connect the circuit opening relay connector.
- b) Use a rag as protection from fuel spray when disconnecting the hoses.  
Plug the hoses after removal.
- c) When inspecting the fuel system, use **SST**.



**MULTI-PRESSURE TESTER (49 9200 750A)**

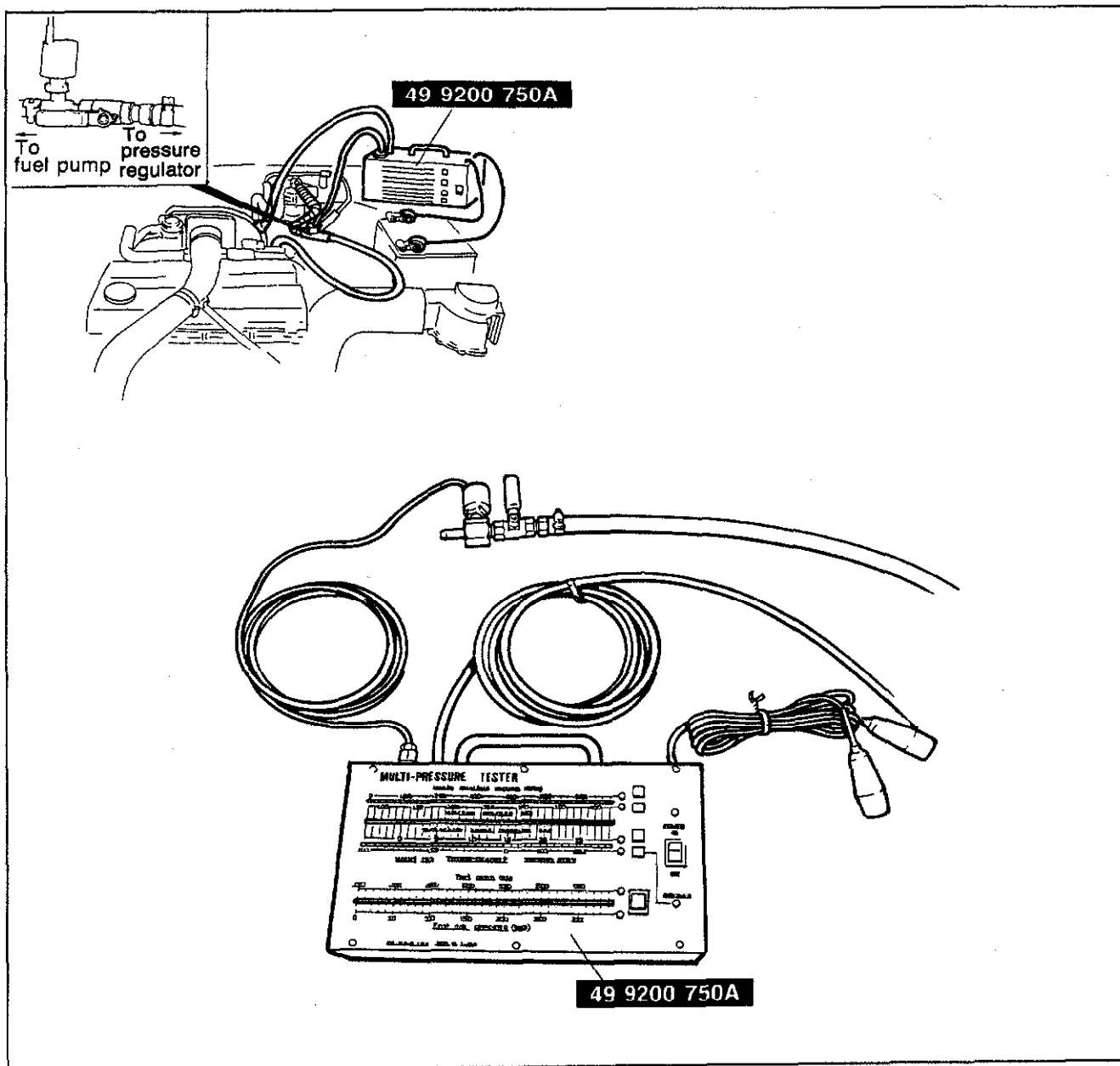

69G04A-099

The **MULTI-PRESSURE TESTER** (49 9200 750A) has been developed to check the fuel pressure and intake manifold vacuum. These can easily be inspected by setting the buttons on the tester.

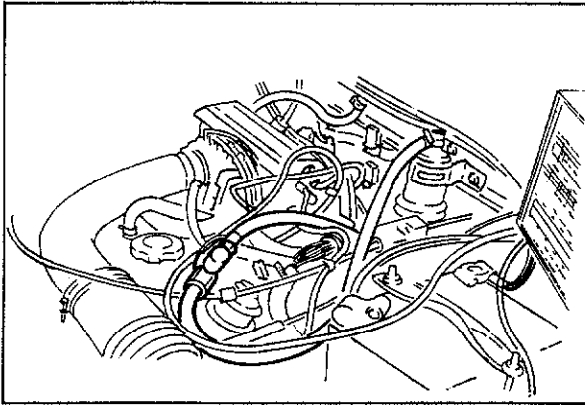

83U04A-048

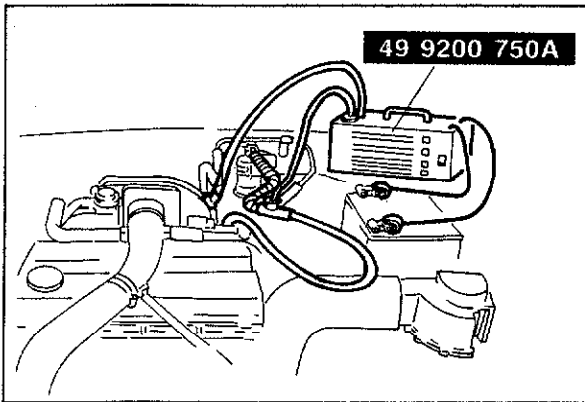

83U04A-201

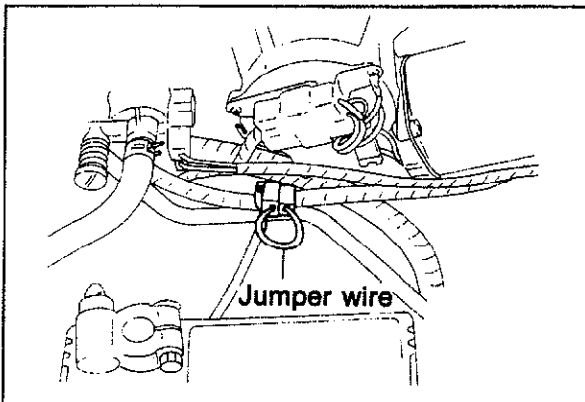

69G04A-102

## How to Connect Multi-Pressure Tester

### Warning

**Before connecting SST, release the fuel pressure from the fuel line to reduce the possibility of injury or fire. (Refer to page 4A—34)**

1. Disconnect the battery negative terminal.
2. Disconnect the fuel main hose from the fuel filter (high pressure side)
3. Connect **SST** between fuel main hose and pressure regulator using the adapter.

### Caution

**Do not reverse the adapter connection.**

4. Disconnect the vacuum hose from the pressure regulator control solenoid valve, and connect **SST** vacuum hose using a three-way joint.
5. Connect the battery negative terminal.
6. Connect **SST** to the battery.

7. Connect the terminals of the test connector (yellow connector) with a jumper wire. Turn the ignition switch ON to operate the fuel pump.
8. Check for fuel leaks.

### Caution

**After checking fuel leakage, turn the ignition switch OFF and disconnect the jumper wire from the test connector.**

## TROUBLESHOOTING CHART

Before performing the following troubleshooting, check the condition of the wiring harness and connector.

POSSIBLE CAUSE	Water thermo sensor	Air flow meter	Intake air thermo sensor	Throttle sensor	Atmospheric pressure sensor	Oxygen sensor	Fuel pressure (Fuel pump pressure, line pressure)	Injector	Engine control unit terminal voltage		
									3C	3E	3B
									4A-68	4A-65	4A-68
SYMPTOM	4A-68	4A-65	4A-68	4A-66	4A-70	4A-69	4A-38	4A-41	4A-61,62		
Hard start or won't start (Crank OK)	3						1	2	5	6	4
Engine stall	While warming up	3	4	5		6		1	2	7	8
	After warming up	3	4	5		6	7	1	2	8	9
Rough idle	While warming up	3	4	5		6		1	2	7	8
	After warming up	3	4	5		6	7	1	2	8	9
Poor acceleration, hesitation or lack of power	4	5		1			2	3	6	7	
Runs rough on deceleration	2							1	3	4	
Afterburn in exhaust system	3	4	5				1	2	6	7	
Poor fuel consumption	3	4	5	6	7	8	1	2	9	10	
Fails emission test	3	4	5	6	7	8	1	2	9	10	

83U04A-049

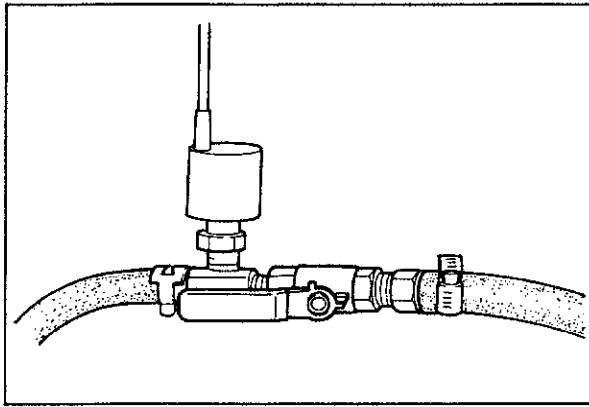

83U04A-050

## FUEL PRESSURE

### Note

- a) When inspecting fuel pressure, use SST. (Refer to page 4A—36)
- b) Warm up the engine to normal operating temperature.

### Injection Pressure

1. Set the lever on the adapter as shown in the figure.

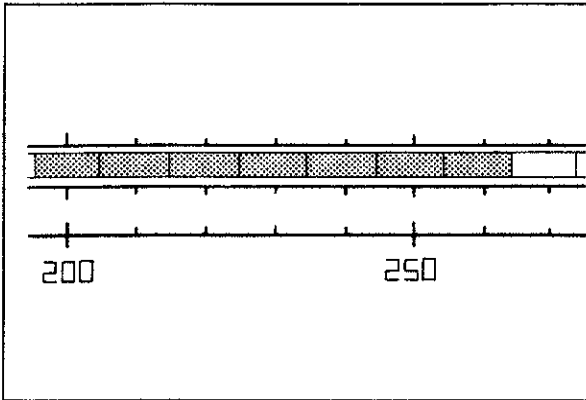

83U04A-051

2. Run the engine and measure the injection pressure at various speeds.

**Injection pressure: Approx. 240—279 kPa  
(2.45—2.85 kg/cm<sup>2</sup>, 34.8—40.5 psi)**

3. If not within specification, check the fuel pump pressure, fuel line pressure, and injector (Refer to page 4A—41)

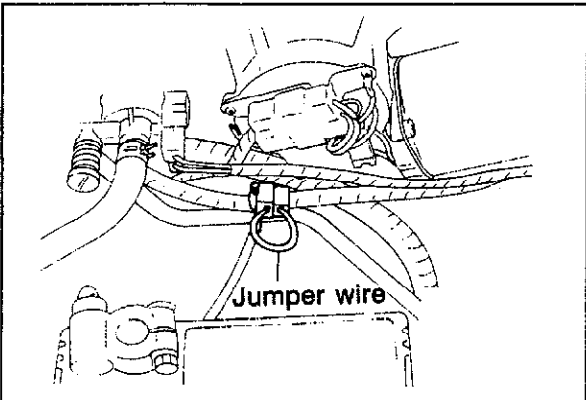

83U04A-052

### Fuel Pump Pressure

1. Connect the terminals of the test connector (yellow connector) with a jumper wire.
2. Turn the ignition switch ON to operate the fuel pump.

3. Move the lever on the adapter as shown in the figure.
4. Check the fuel pump pressure.

**Fuel pump pressure: 441—588 kPa  
(4.5—6.0 kg/cm<sup>2</sup>, 64.0—85.3 psi)**

5. If the fuel pump pressure is not within specification, check the followings.

### No pressure

**Fuel pump operation (Refer to page 4A—40)**

### Low pressure

**Fuel pump feeding capacity (Refer to page 4A—40)**

### High pressure

**Replace the fuel pump**

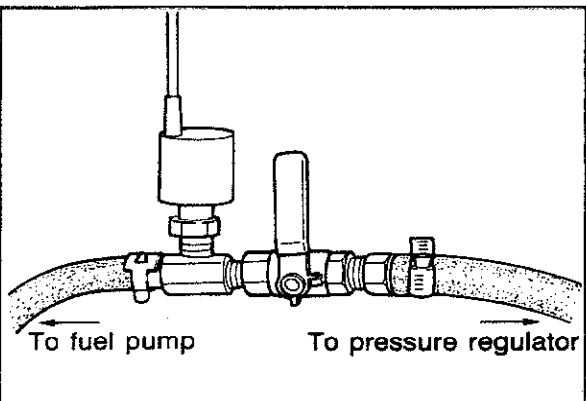

83U04A-053

6. After checking the fuel pump pressure, disconnect the jumper wire from the test connector.

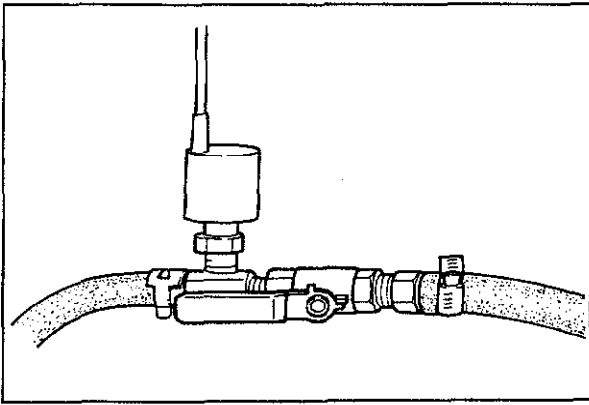

83U04A-054

## Fuel line Pressure

1. Start the engine and run it idle.
2. Move the lever on the adapter as shown in the figure.
3. Check the fuel line pressure.

**Fuel line pressure: Approx. 177—216 kPa  
(1.8—2.2 kg/cm<sup>2</sup>, 24.6—31.3 psi)**

4. If not within specification, check the vacuum hose.

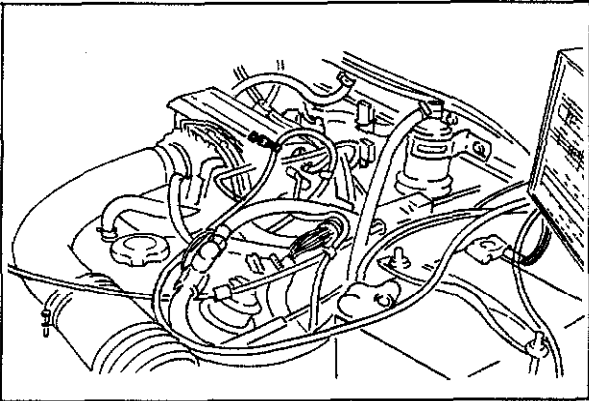

83U04A-055

5. Pinch a vacuum hose of pressure regulator.
6. Check the fuel line pressure.

**Fuel line pressure: 240—279kPa  
(2.45—2.85 kg/cm<sup>2</sup>, 34.8—40.5 psi)**

7. If not within specifications, replace the pressure regulator.
8. Connect the vacuum hose to pressure regulator.

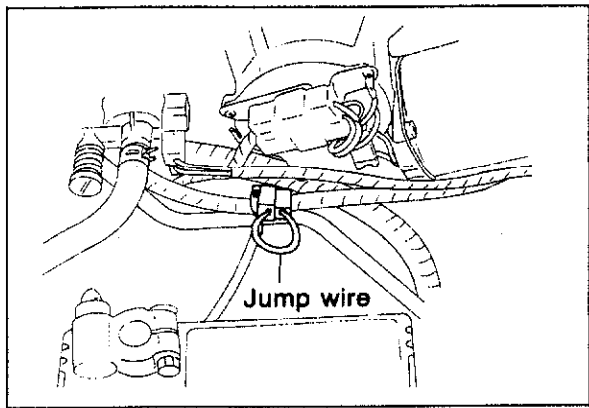

83U04A-056

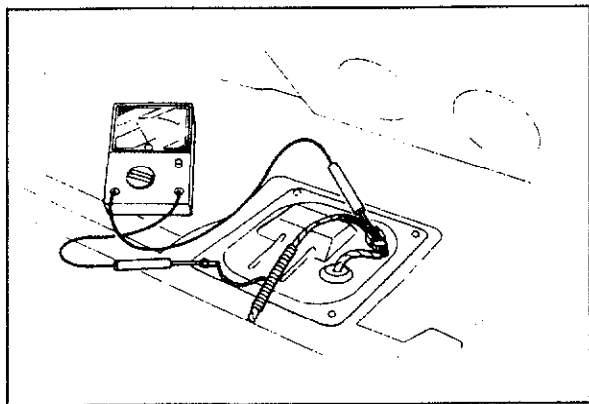

83U04A-057

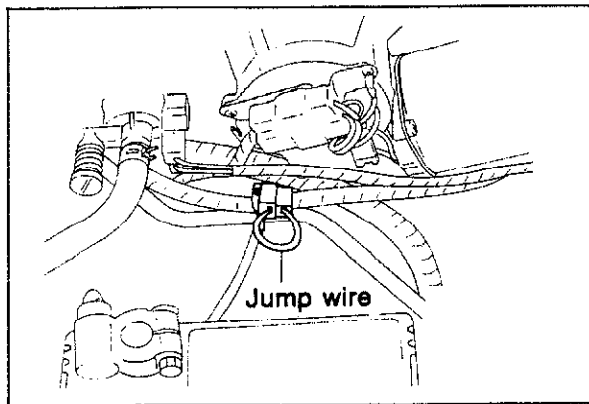

83U04A-058

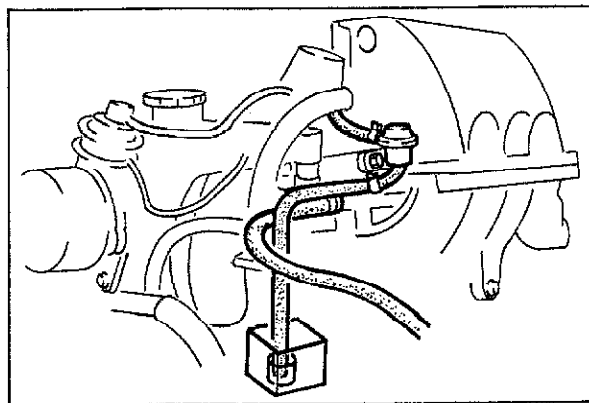

83U04A-059

## INSPECTION

### Fuel Pump (Operation Test)

1. Connect a jumper wire to the check connector (Yellow connector).
2. Open the fuel tank lid, and fuel filler cap.
3. Turn the ignition switch ON.
4. Check that the fuel pump operation sound.
5. Shut the fuel filler cap, and fuel tank lid.

6. If operation sound is not produced, check the voltage at the fuel pump connector.

### Voltage: 12V

(IG: ON, Voltmeter [GR and B] connected)

7. If the voltage normal, replace the fuel pump.

### Fuel pump (Volume test)

#### Warning

Before performing following procedures, release the fuel pressure to reduce the possibility of injury or fire. (Refer to page 4A—34)

1. Connect a jumper wire to check connector (Yellow connector).
2. Disconnect the fuel return hose from fuel return pipe.

3. Turn the ignition switch ON for 10 seconds, and check the feeding capacity with graduated cylinder.

**Feeding capacity: 220—380 cc (13.4—23.2 cu-in) when fuel pressure at 250 kPa (2.55 kg/cm<sup>2</sup>, 36.3 psi)**

4. If not within specification, check the fuel filter, and fuel line.

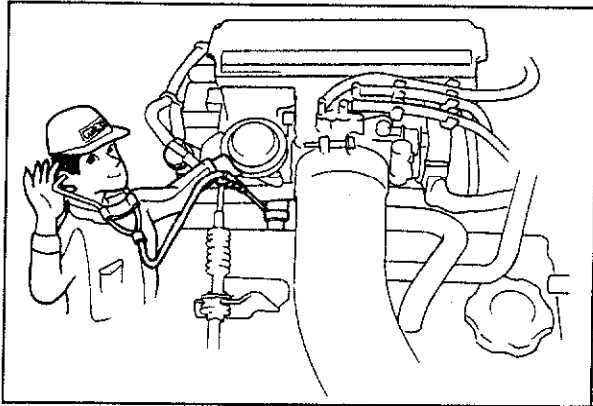

83U04A-060

### Injector (On-vehicle inspection)

1. Warm up the engine and run at idle.
2. Check the operating sound of the injector, using a sound scope. Check that operating sounds are produced from each injector at idle and at acceleration.
3. If operating sound is not produced, check the followings.
  - Wiring harness
  - Injector resistance
  - Engine control unit terminal voltage of 3C, 3E, 3B, and 3D (refer to page 4A—62).

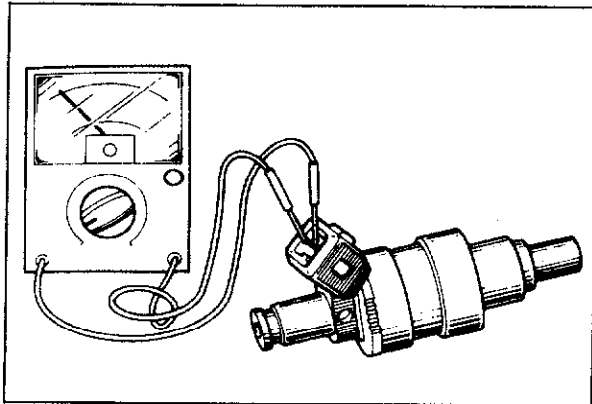

83U04A-061

### Injector (Resistance)

#### Warning

**Before performing following procedures, release the fuel pressure to reduce the possibility of injury or fire. (Refer to page 4A—34)**

1. Remove the injector from the engine. (Refer to page 4A—44)
2. Check that the resistance of the injector.

**Resistance: 11—15  $\Omega$**

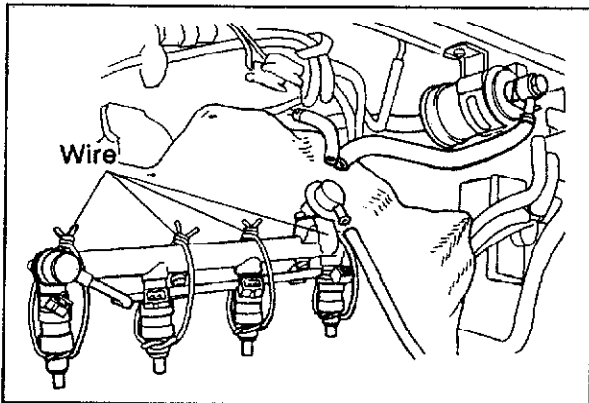

83U04A-062

### Injector (Leak test)

#### Warning

**Before performing following procedures, release the fuel pressure to reduce the possibility of injury or fire. (Refer to page 4A—34)**

1. Remove the delivery pipe, injector, and pressure regulator. (Refer to page 4A—44)
2. Affix the injectors to the distribution pipe with wire.

#### Caution

**Affix the injectors firmly to the distribution pipe so no movement of the injectors is possible.**

3. Connect the distribution pipe assembly between the fuel filter and the return pipe.
4. Connect the return hose to the pressure regulator.
5. Connect the negative terminal of the battery.

#### Warning

**Be extremely careful when working with fuel; always work away from sparks or open flames.**

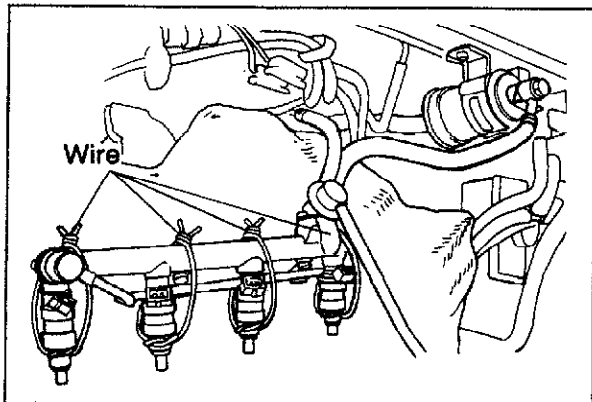

83U04A-063

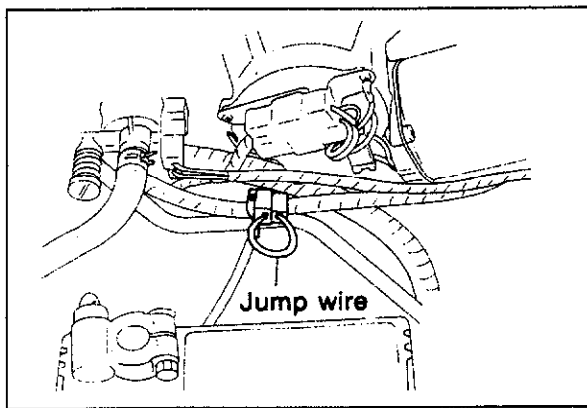

83U04A-064

6. Connect a jumper wire to the check connector (Yellow terminal).
7. Turn the ignition switch ON.
8. Check that fuel does not leak from injector.

#### Note

**After 5 minutes a very slight amount of fuel leakage from the injector is acceptable.**

9. If fuel leaks, replace the injector.

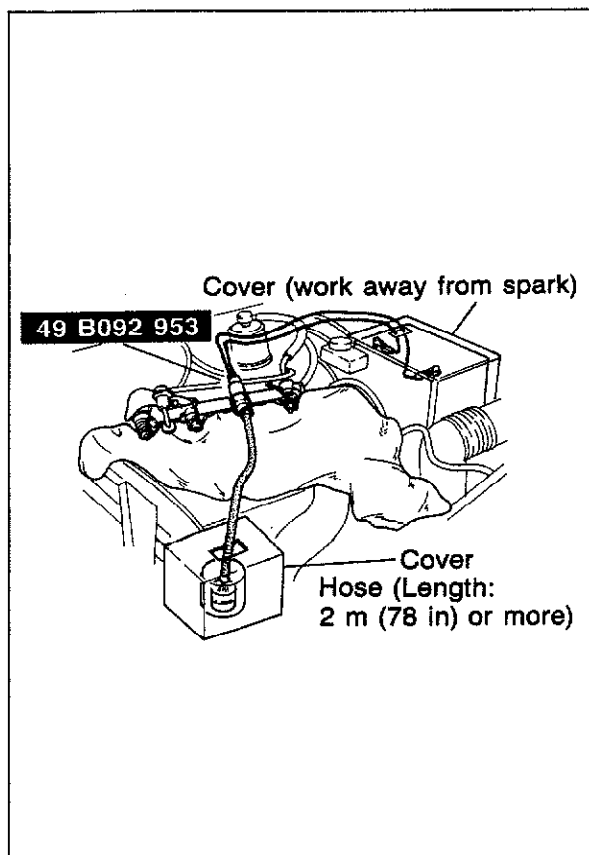

83U04A-065

#### Injector (Volume test)

1. Connect a suitable vinyl hose to the injector and place the hose in the container, or graduated glass etc.

#### Note

**The hose should be 2 m (78 in) or more**

2. Connect the terminals of the fuel pump check connector with a jumper wire.

#### Warning

**Be extremely careful when working with fuel; always work away from sparks or open flames.**

3. Apply battery voltage to each injector, using the SST.
4. Turn the ignition switch ON.
5. Check the injection volume.

**Specification: 32—41 cc  
(1.95—2.50 cu in)/15 sec.**

6. If not correct, replace the injector.



## REMOVAL AND INSTALLATION

### Caution

- a) Before performing the following procedure, release the fuel pressure from the fuel line to reduce the possibility of injury or fire (Refer to page 4A—34).
- b) When servicing the fuel system, keep sparks, cigarettes and open flames away from the fuel.

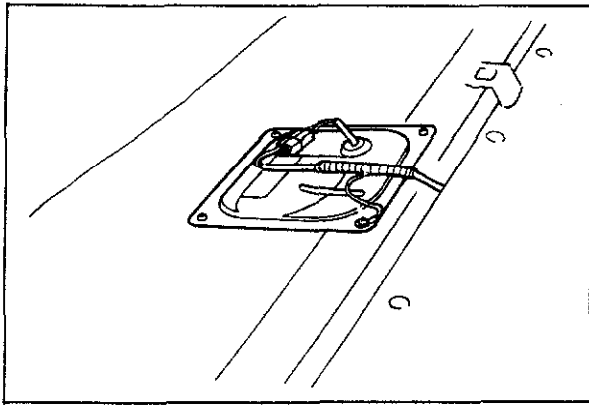

83U04A-066

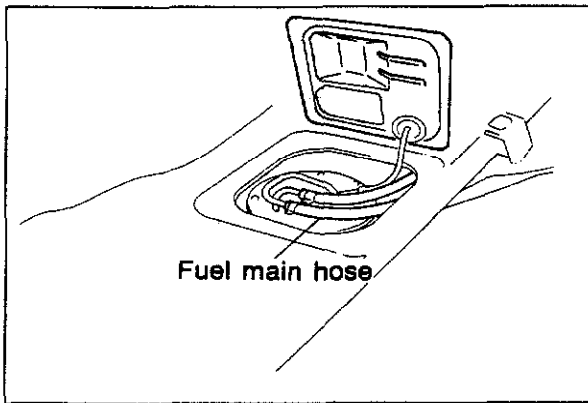

83U04A-067

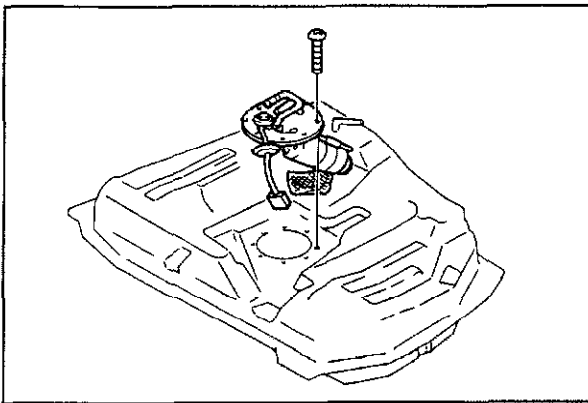

83U04A-068

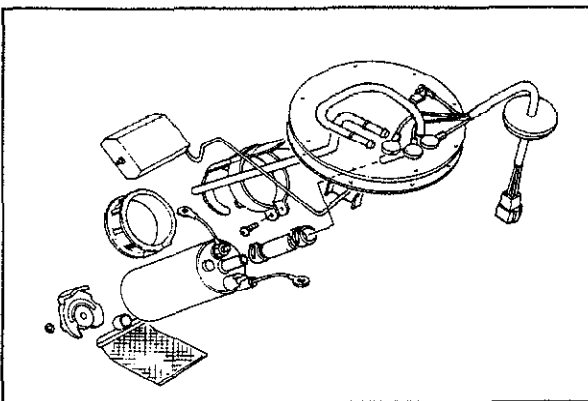

83U04A-069

### Fuel Pump

1. Remove the rear seat.
2. Remove the filler cap.
3. Disconnect the fuel pump connector.
4. Remove the fuel pump cover.
5. Disconnect the fuel main and return hoses, then plug them to prevent fuel leakage.
6. Remove the fuel pump and fuel tank gauge unit assembly.

### Warning

**Use of fire or smoking is strictly prohibited while working on the fuel system.**

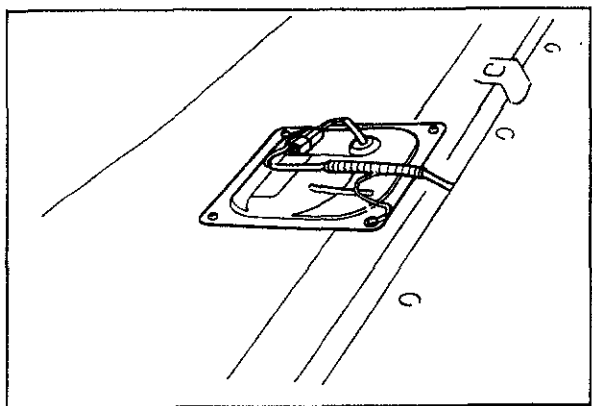

83U04A-070

7. Replace the fuel pump.

**Caution**

**Secure the fuel pump terminals and fuel hose.**

8. Install the fuel pump and fuel tank gauge unit assembly in the reverse order of removal.

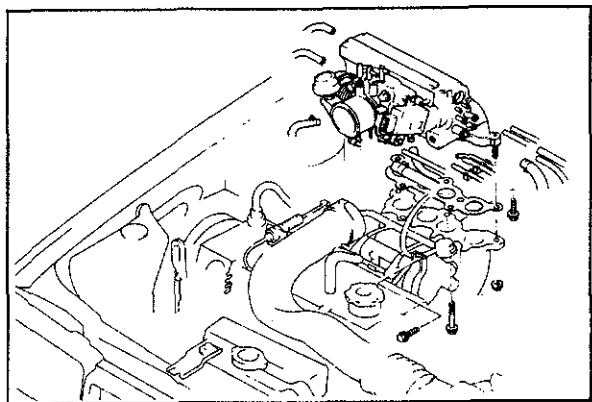

83U04A-071

**Pressure Regulator**

1. Remove the dynamic chamber. (Refer to page 4A—26)

2. Disconnect the fuel return hose.

3. Remove the pressure regulator.

4. Install the pressure regulator and dynamic chamber in the reverse order of replacement.

**Tightening torque:**

**7.8—8.7 N·m (0.8—1.1 m·kg, 5.8—8.0 ft·lb)**

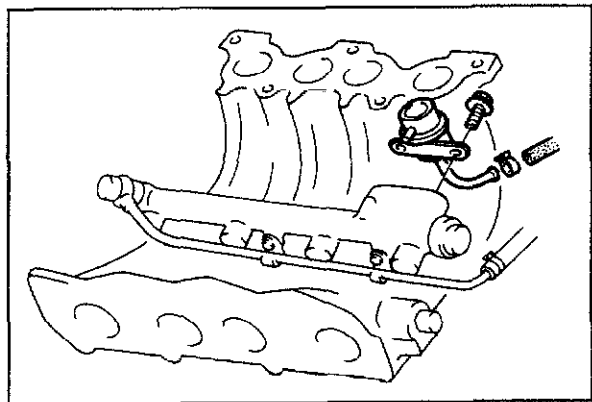

83U04A-072

**Injector**

1. Remove the dynamic chamber. (Refer to page 4A—26)

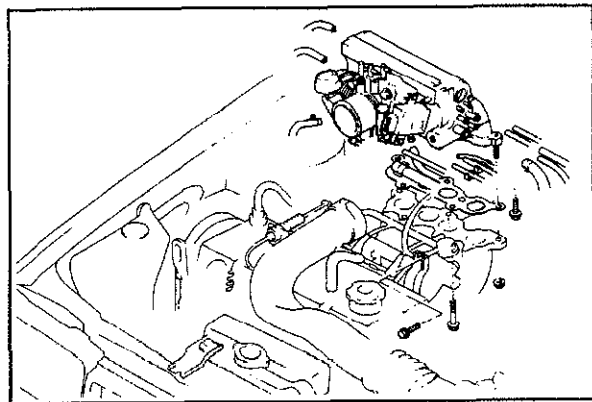

83U04A-073

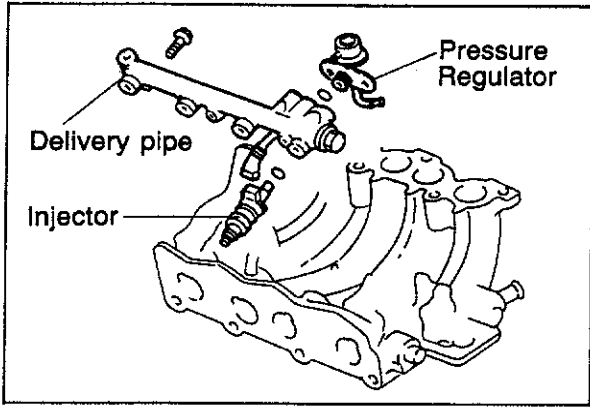

83U04A-074

2. Disconnect the connectors from injector.
3. Remove the delivery pipe with pressure regulator.
4. Remove the injector.
5. Install the injector, delivery pipe, and pressure regulator in the reverse order of replacement.

### Delivery pipe tightening torque

18.6—25.5 N·m

(1.9—2.6 m·kg, 13.7—18.8 ft·lb)

### Note

a) O-ring of injector is not reusable.

b) When install the injector, apply the gasoline on O-ring.

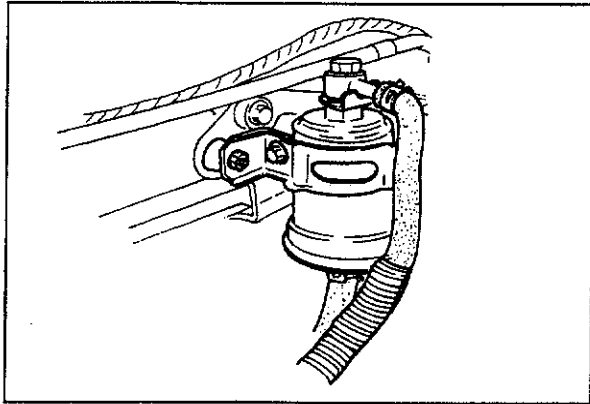

83U04A-075

### Fuel Filter (High Pressure)

The fuel filter should be replaced at intervals, following the maintenance schedule.

To replace the fuel filter, proceed as follows:

1. Disconnect the fuel hoses.
2. Remove the fuel filter with the bracket.
3. Install a new filter and connect the fuel hoses.

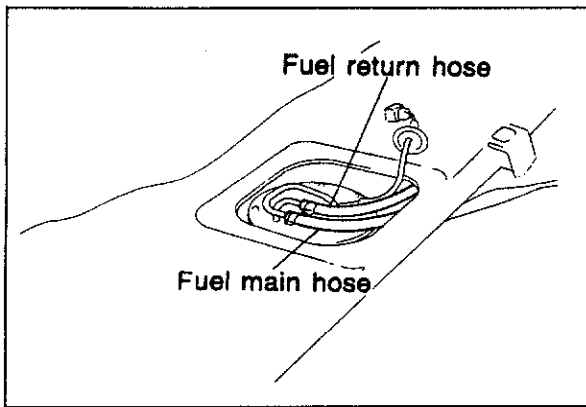

83U04A-076

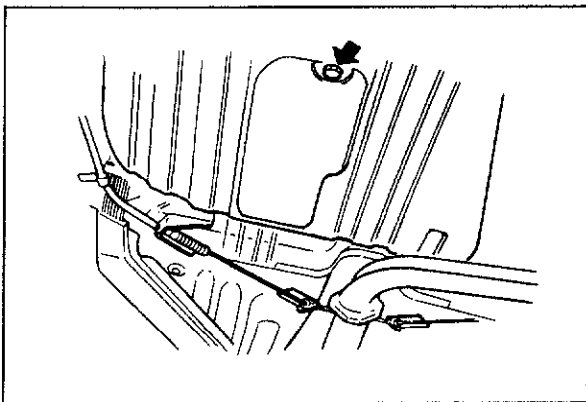

63U04B-067

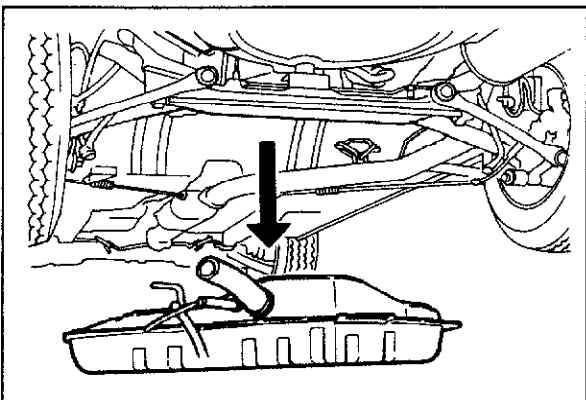

63U04B-068

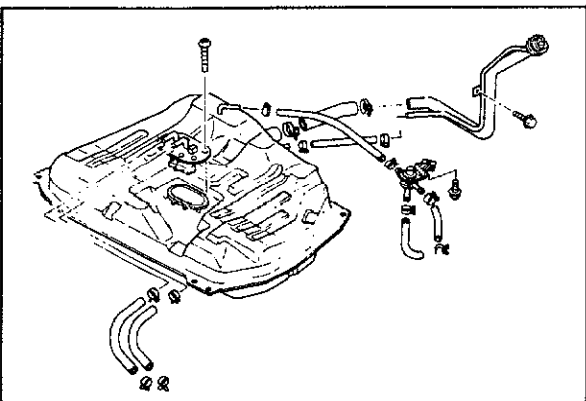

63U04B-069

## FUEL TANK Removal

### Warning

Before performing following procedures, release the fuel pressure to reduce the possibility of injury or fire. (Refer to page 4A—34)

1. Remove the rear seat cushion.
2. Disconnect the fuel tank gauge unit and remove the cover.
3. Disconnect the fuel main and return hoses.

4. Raise the vehicle on a jack and support it with safety stands.
5. Remove the drain plug and drain the fuel.

### Warning

a) When repairing the fuel tank, clean the fuel tank thoroughly with steam to remove all explosive gas.

b) Use of fire is strictly prohibited while working on fuel tank.

6. Disconnect the other hoses.
7. Remove the fuel tank.

## Installation

Install in reverse order of removal and be careful of the following;

1. Make sure to connect the hoses in the correct positions.
2. Check for leaks.

## DECELERATION CONTROL SYSTEM

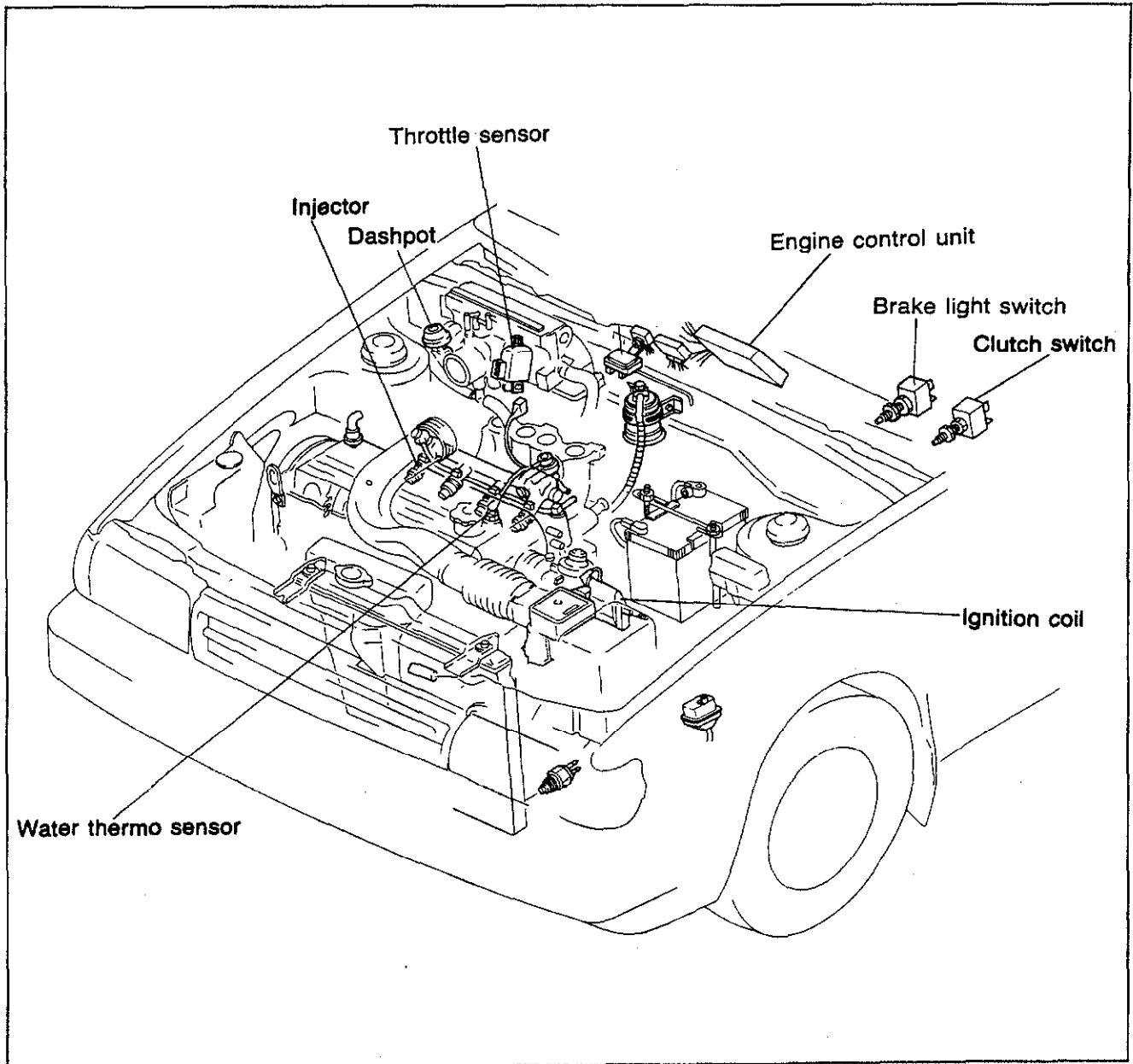

83U04A-077

The fuel cut function is provided in the deceleration control system. This function is to improve fuel consumption.

## TROUBLESHOOTING CHART

POSSIBLE CAUSE  Page	Water thermo sensor	Injector	Engine control unit terminal voltage		Dashpot				
			3C	3E					
			4A-68	4A-41					
<b>SYMPTOM</b>									
Runs rough on deceleration	③	②	①	④					
Afterburn in exhaust system	②	①	③	④					
Poor fuel consumption	②	①	③	④					
Fail emission test	③	②	①	④					

83U04A-078

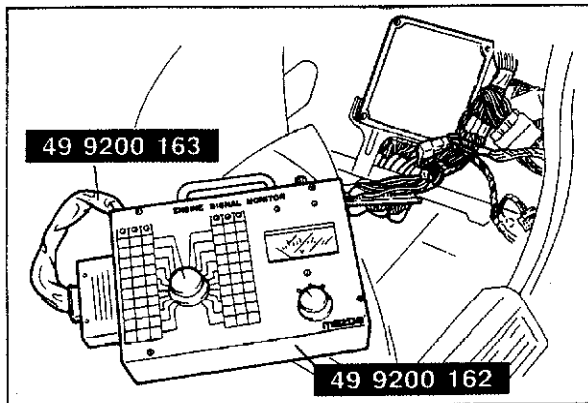

83U04A-079

### System Inspection (Electrical Signal)

1. Connect **SST** between the wiring harness and engine control unit.
2. Warm up the engine, and run at idle.
3. Set "3C" and "3E" position on **SST**.

#### Note

- "3C" — For No. 2 and No.4 injectors
- "3E" — For No. 1 and No.3 injectors

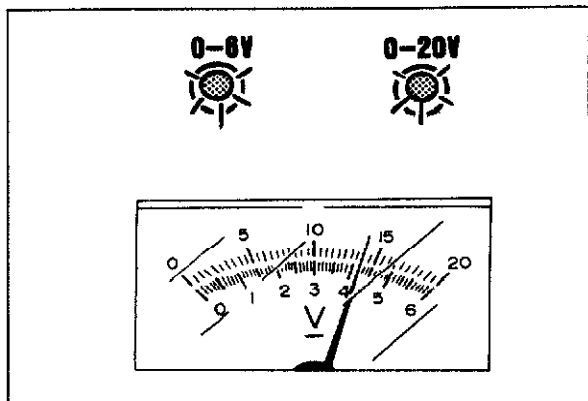

83U04A-080

4. Check that both indicator lamps flash at idle.

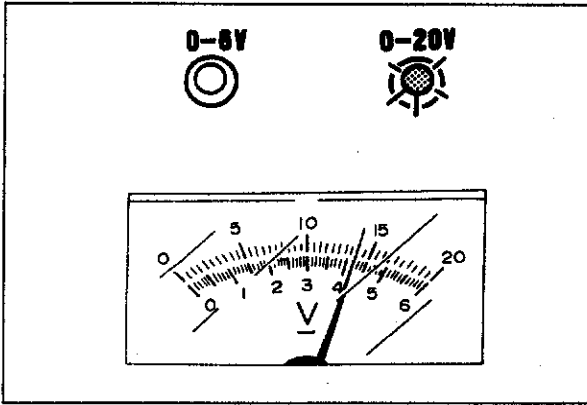

83U04A-081

5. Increase the engine speed to **4,000 rpm**, then suddenly decrease the engine speed.
6. Check that only the red indicator lamp illuminates during deceleration.

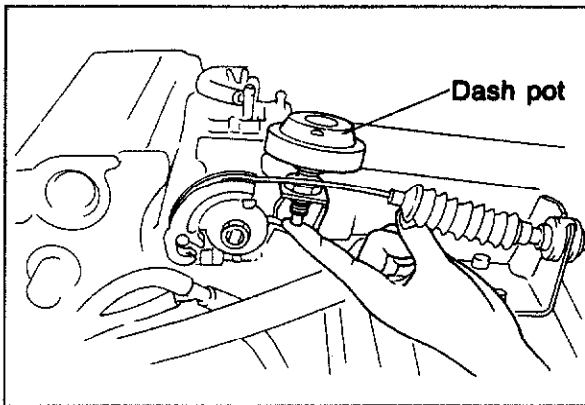

83U04A-082

### Dashpot Inspection

1. Push the dashpot rod with a finger and make sure the rod goes into the dashpot slowly.
2. Release the finger and make sure the rod comes out quickly.

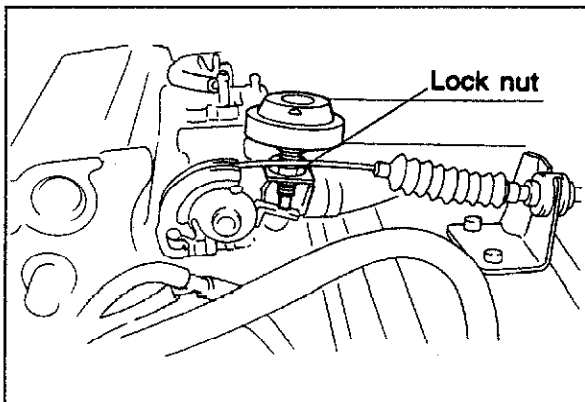

83U04A-083

### Adjustment

1. Warm up the engine to the normal operation temperature and run it at idle speed.
2. Attach a tachometer.
3. Increase the engine speed above **3,500 rpm**.
4. Slowly decrease the engine speed, check the dashpot rod touches the lever at specified speed.

**Contact speed: 2,800 ± 150 rpm (MTX)  
2,800 ± 300 rpm (ATX)**

5. To adjust, loosen the lock nut and adjust by turning the dashpot, tighten lock nut after adjusting.

## HIGH ALTITUDE COMPENSATION SYSTEM

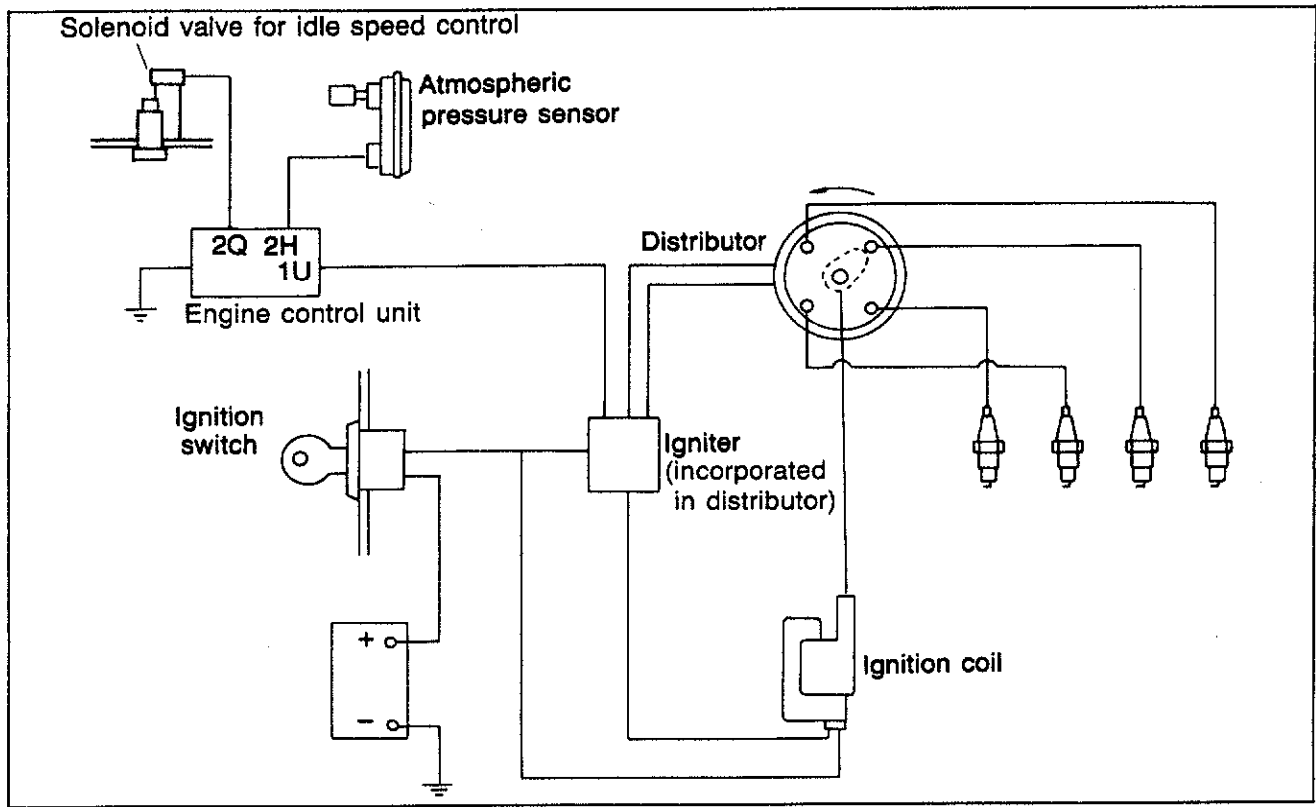

63U04B-081



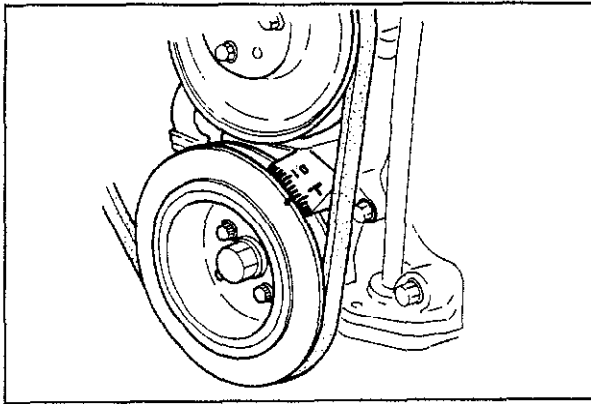

63U04B-082

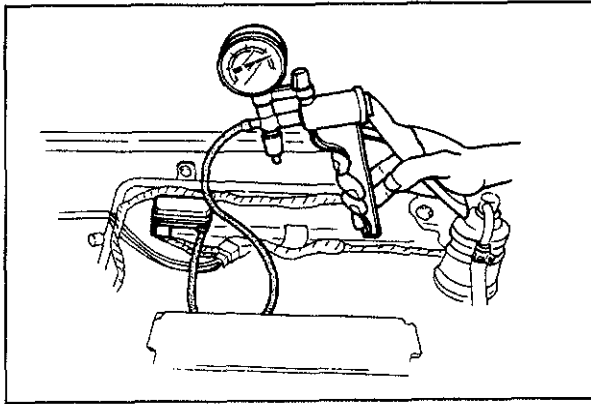

83U04A-121

## SYSTEM INSPECTION CHECKING

### Note

This procedure described is for sea level areas only.

1. Warm up the engine and run it at idle.
2. Connect a timing light to the No.1 high-tension lead and check the ignition timing.

**Ignition timing: approx. 7° BTDC (vacuum connected)**

3. Connect a vacuum pump to the atmospheric pressure sensor.
4. Apply a vacuum of **120 mmHg (4.72 inHg)** by using the vacuum pump and check the ignition timing.

**Ignition timing: approx. 13° BTDC**

### Note

**At 1,000 m (3,280 ft) or higher altitude area, the ignition timing is the same as above.**

5. If this system does not operate inspect the atmospheric pressure sensor (Refer to page 4A-70), and engine control unit (Refer to page 4A-61, 62)

## EVAPORATIVE EMISSION CONTROL SYSTEM

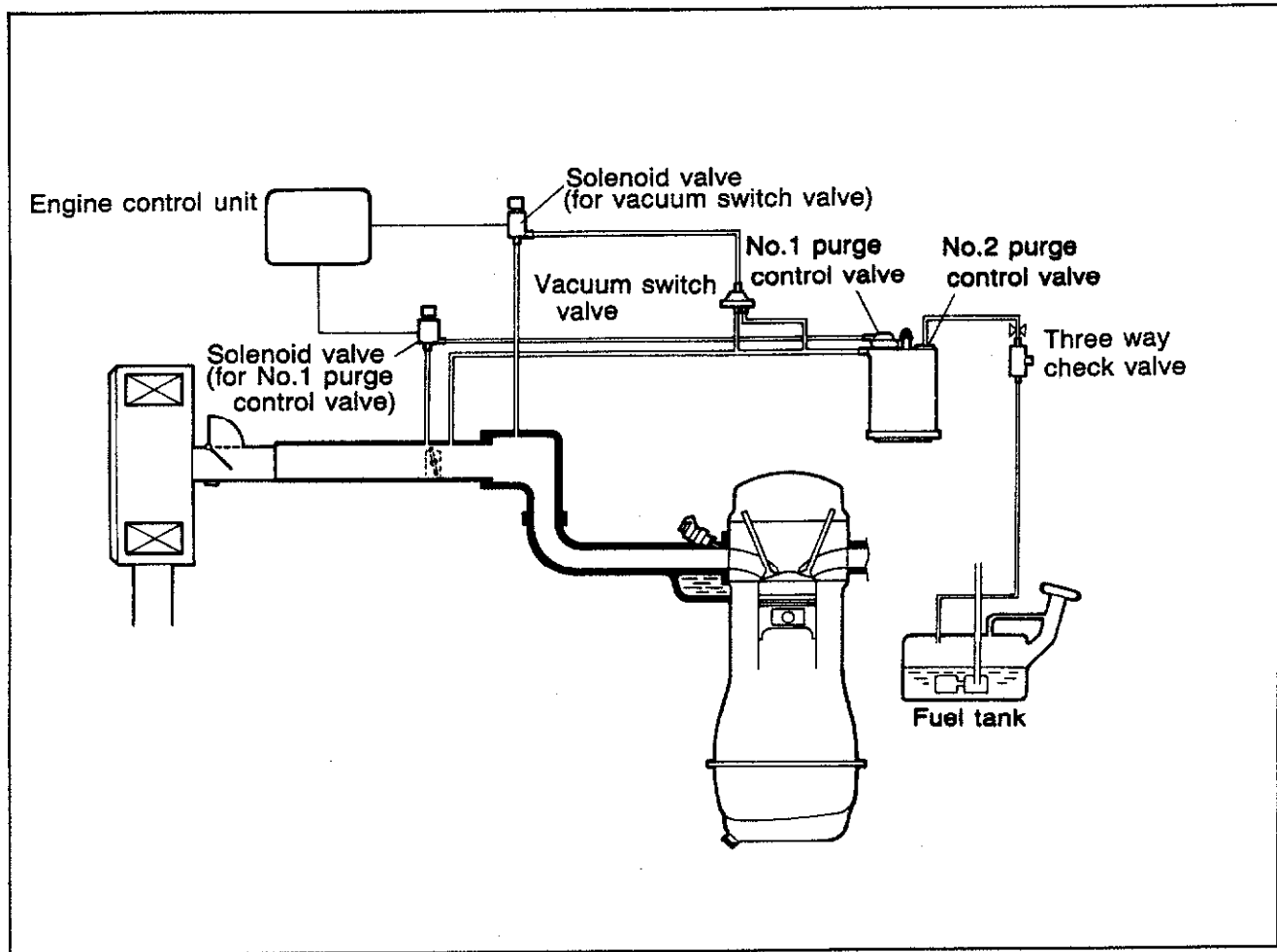

83U04A-084

The evaporative emission control system is controlled by signal from the water thermo sensor, intake air thermo sensor, air flow sensor, and engine speed sensor (ignition coil). The engine control unit determined the engine operating conditions from the signals, and control the evaporative emission control system by operating the solenoid valves for No. 1 purge control valve and vacuum switch valve when specified conditions exist.

### TROUBLE SHOOTING CHART

POSSIBLE CAUSE	Ignition coil	Water thermo sensor	Intake air thermo sensor	Engine control unit		Solenoid valve (for No.1 vacuum switch valve)	Solenoid valve (for vacuum switch valve)	Vacuum switch valve	No.1 purge control valve	No.2 purge control valve	Three-way check valve
				2O	2P						
SYMPTOM	5-30	4A-68	4A-68	4A-62		4A-54		4A-55	4A-54	4A-54	4A-55
Checking order	(11)	(10)	(9)	(3)	(4)	(1)	(2)	(7)	(5)	(6)	(8)

83U04A-999

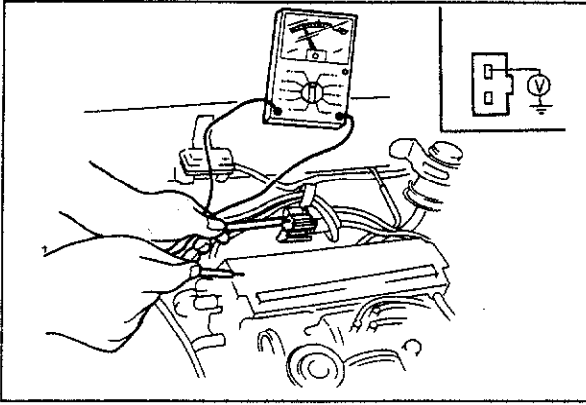

83U04A-203

## SYSTEM INSPECTION

1. Warm up the engine and run it at idle.
2. Connect a voltmeter to the solenoid valve for No.2 purge control valve (BY) terminal

**Voltage: approx. 12V**

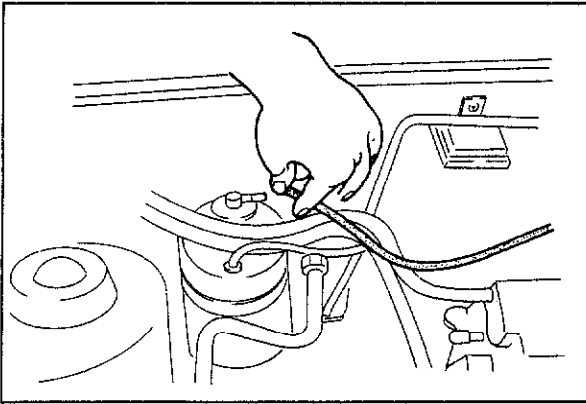

63U04B-095

3. Disconnect the vacuum hose from the No. 1 purge control valve and place a finger over the hose opening.
4. Increase the engine speed to about **2,000 rpm** and make sure air is not sucked in.

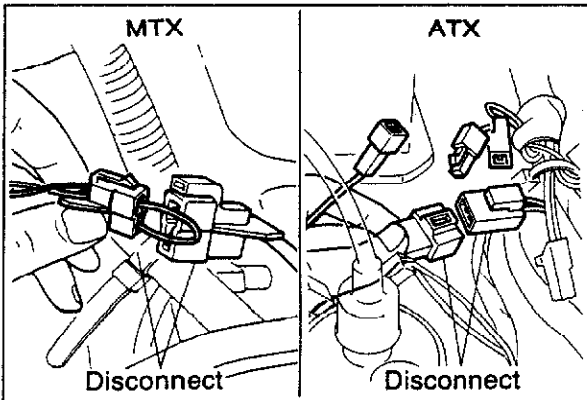

83U04A-085

5. Disconnect the neutral switch connector and connect a jump wire to the neutral switch connector (MTX).  
(Disconnect the inhibitor switch connector...ATX)
6. Check the terminal voltage (BY)

**Voltage: below 1.5V**

7. Place finger over the hose opening.
8. Increase the engine speed to about **2,000 rpm** and check that air is sucked in.
9. If not correct, check the solenoid valve, for No.1 purge control valve engine control unit 2P terminal, and No.1 purge control valve.
10. Connect the neutral switch connector.

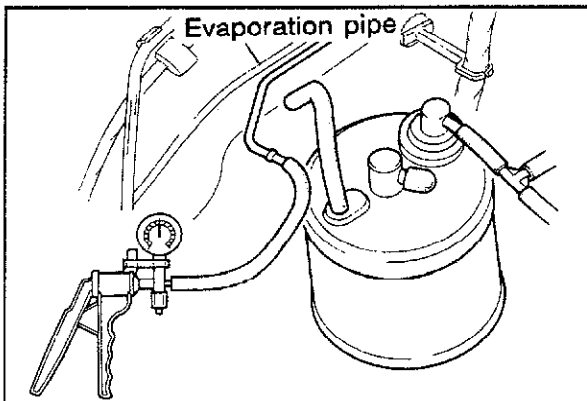

83U04A-087

11. Disconnect the evaporation hose from the evaporation pipe.
12. Connect the vacuum pump to the evaporation pipe.
13. Operate the vacuum pump and check that no vacuum is held.
14. If vacuum is held, check the three-way check valve or evaporation pipe for clog.

# 4A EVAPORATIVE EMISSION CONTROL SYSTEM

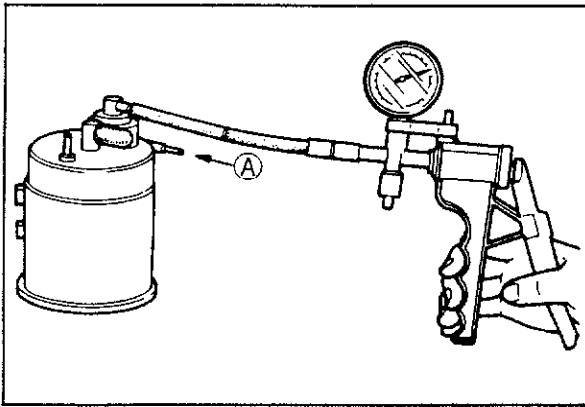

56G04A-449

## NO. 1 PURGE CONTROL VALVE

### Inspection

1. Blow through the purge control valve from port (A) and check that air does not flow.
2. Connect a vacuum pump to the purge control valve.
3. Apply **110 mmHg (4.33 inHg)** vacuum, and blow through port (A) again; air should flow from port (A).

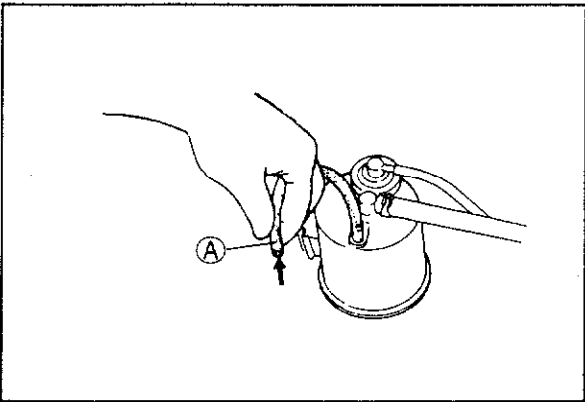

83U04A-204

## NO. 2 PURGE CONTROL VALVE

### Inspection

1. Disconnect vacuum hose (A) from the evaporation pipe.
2. Blow into the hose and check that air flows freely.

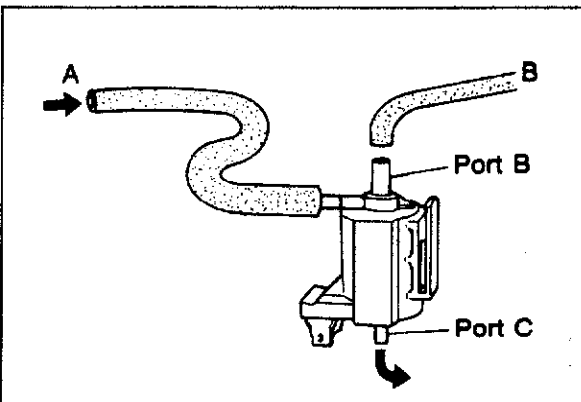

63U04B-097

## SOLENOID VALVE

1. Disconnect vacuum tube (A) from the servo diaphragm.
2. Disconnect vacuum tube (B) from the solenoid valve.
3. Disconnect the connector of the solenoid valve.
4. Blow air through the solenoid valve from tube (A) and make sure air comes out of port (C).

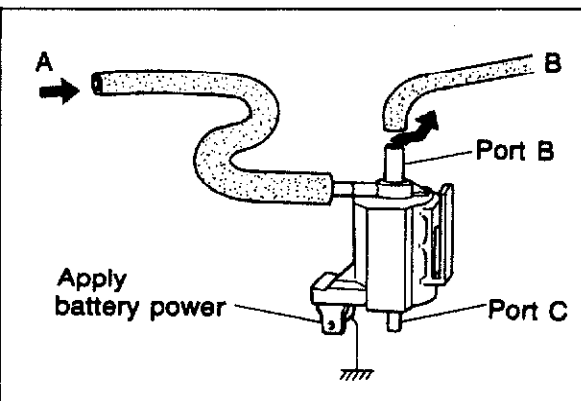

83U04A-089

5. Apply battery power to the solenoid valve with a suitable jump wire.
6. Blow air through the solenoid valve from tube (A) and check that air comes out of port (B).
7. If the solenoid valve does not operate properly, replace it with a new one.

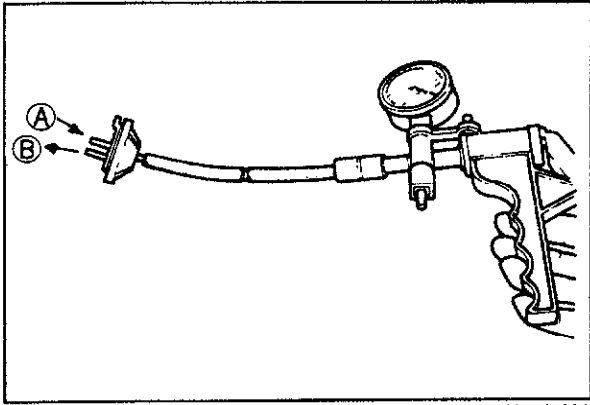

83U04A-090

## VACUUM SWITCH VALVE

1. Remove the No. 3 purge control valve.
2. Connect a vacuum pump to the valve.
3. Blow through the valve from port (A) and confirm that air comes out of port (B) when applied vacuum is more than the specified vacuum amount.

### Specified vacuum:

**70—100 mmHg (2.76—3.94 inHg)**

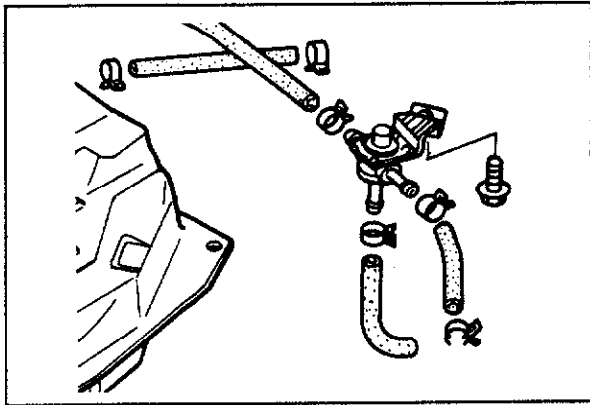

63U04B-102

## THREE-WAY CHECK VALVE

1. Remove the three-way check valve.

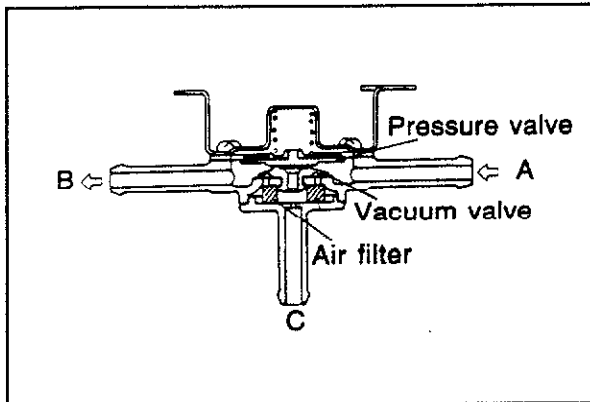

63U04B-103

2. Blow through the valve from port (A), and check that air flows out through port (B). Next, block port (B), and check that air flows out through port (C).
3. Block port (B), and suck through port (A). Check that air is pulled in through port (C).

## POSITIVE CRANKCASE VENTILATION (PCV) SYSTEM

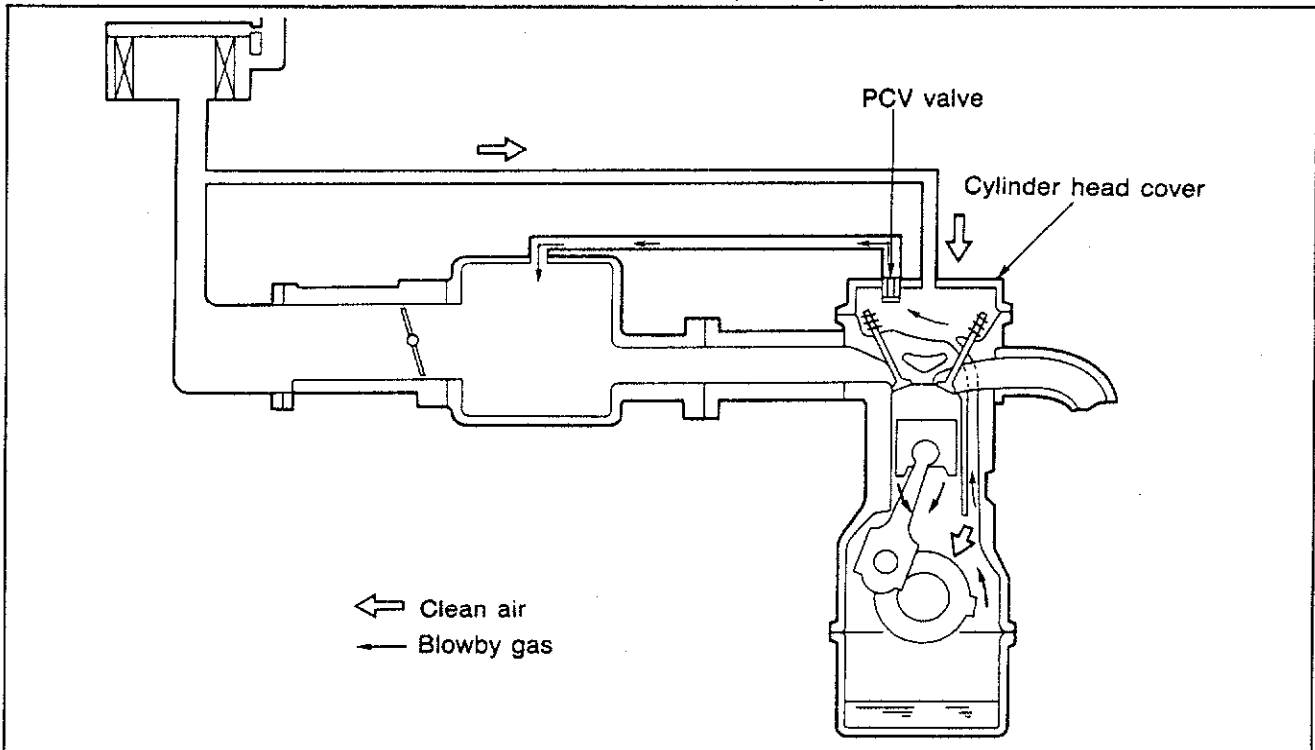

83U04A-091

The PCV valve is operated by intake manifold vacuum to prevent blow-by gas from escaping to the atmosphere. When the engine is running at idle, the PCV valve is slightly opened and small amount of blow-by gas is drawn into the dynamic chamber.

At high engine speed, the PCV valve is further opened and large amount of blow-by gas; drawn into the dynamic chamber.

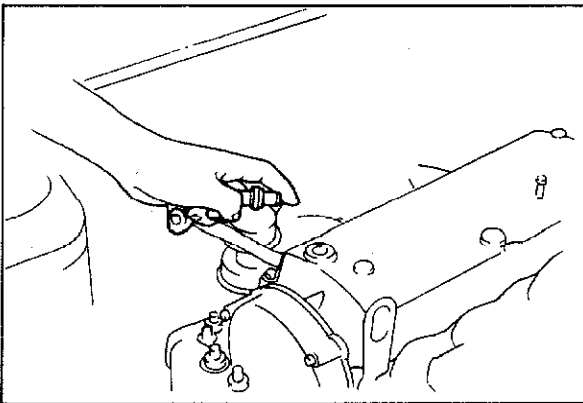

83U04A-118

### PCV VALVE Inspection

1. Warm up the engine to the normal operating temperature and run it at idle speed.
2. Disconnect the PCV valve with the ventilation hose from the cylinder head cover.
3. Block the PCV valve opening by finger.  
If the engine speed drops, the PCV valve is working properly.

**CONTROL SYSTEM**

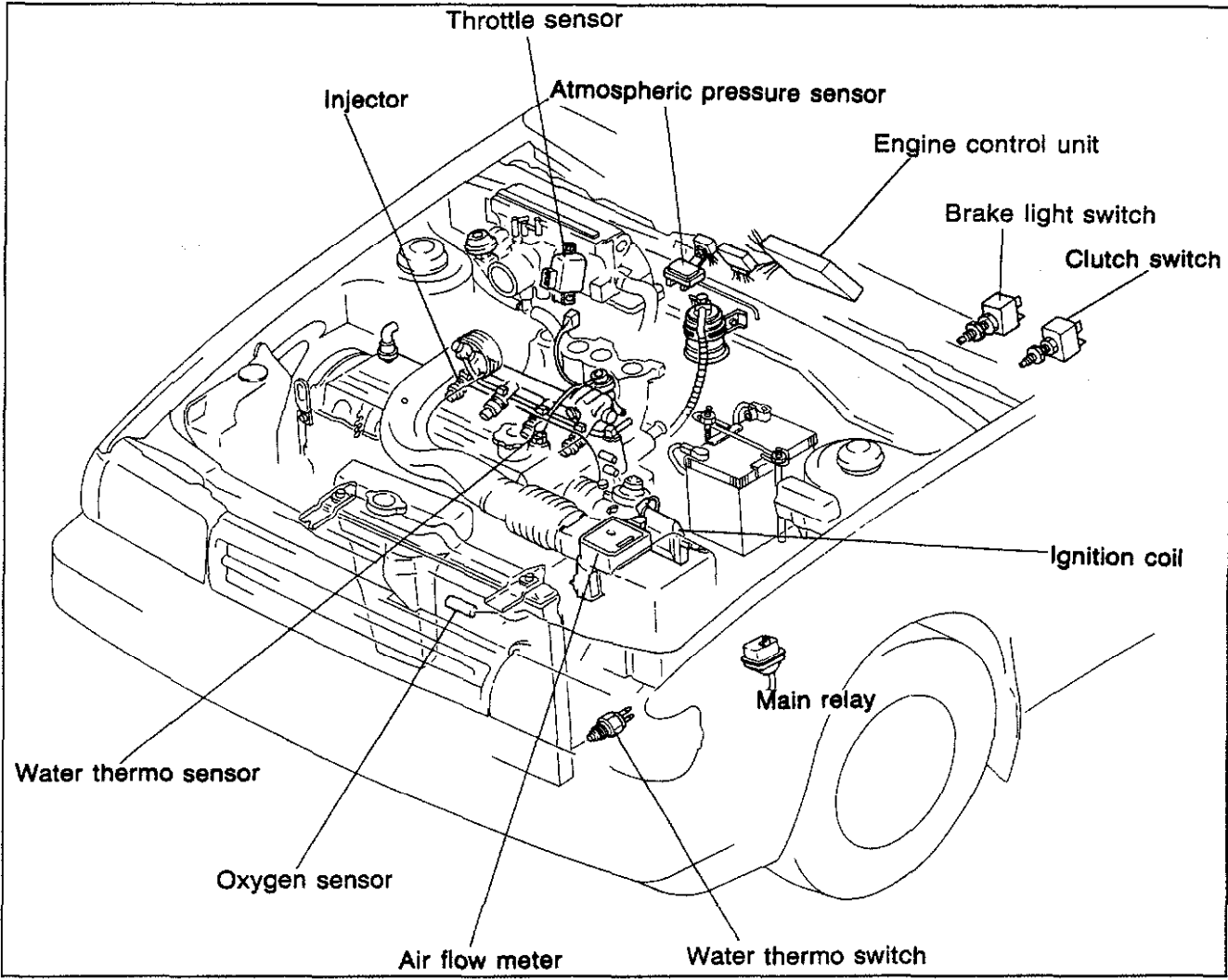

83U04A-092

The control system consists of the input devices and control unit.  
The control unit controls the injection amount, monitor switch function, and fail-safe function.

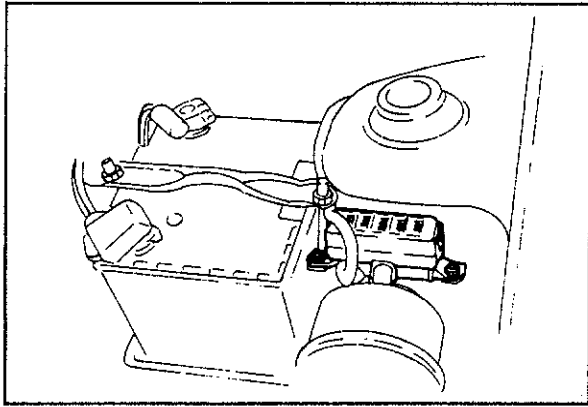

83U04A-093

## MAIN FUSE

### Inspection

Check the continuity of EGI main fuse.

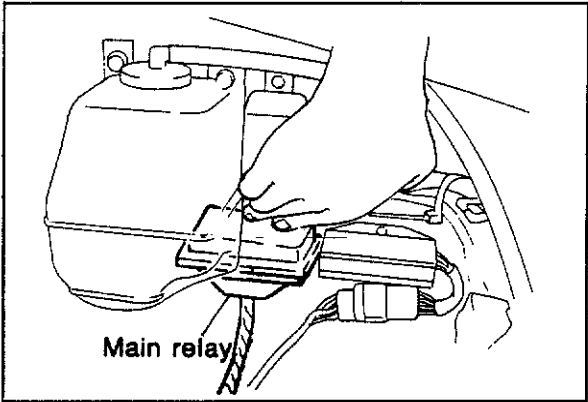

83U04A-094

## MAIN RELAY

### Inspection

1. Turn ignition switch ON and OFF, verify that the main relay "CLICKS".
2. If clicking is not heard at main relay correct, check the continuity at terminals using an ohmmeter, and wiring harness.

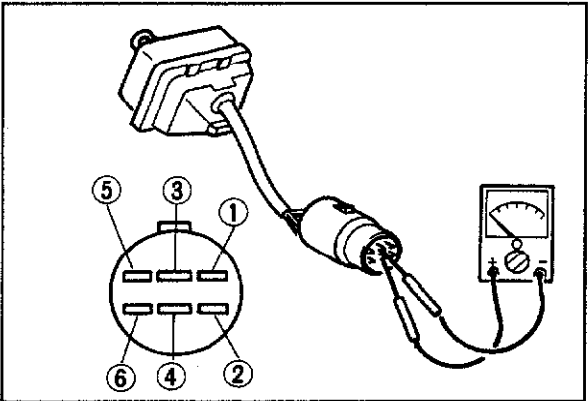

83U04A-095

### Continuity

1. Apply 12V to ⑤ and a ground ⑥ terminals of the main relay.
2. Check continuity at terminals using an ohmmeter.

Operation Terminals	12V Not applied	12V Applied
①—②	No	Yes
③—④	No	Yes

3. If not correct, replace it.

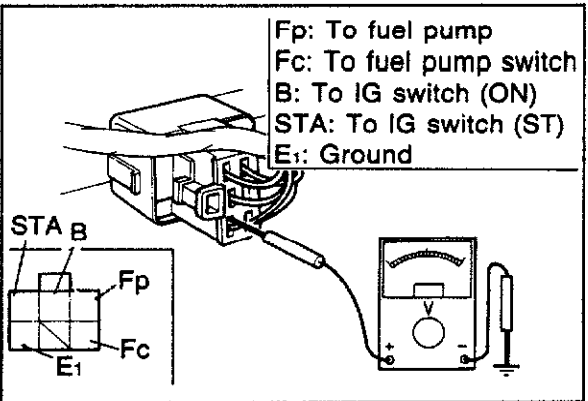

83U04A-096

Fp: To fuel pump  
 Fc: To fuel pump switch  
 B: To IG switch (ON)  
 STA: To IG switch (ST)  
 E1: Ground

## CIRCUIT OPENING RELAY

### Inspection

#### Terminal voltage

1. Check voltage between each terminal and ground using a voltmeter.

Condition	Terminal	Fp	Fc	B	STA	E1
IG SW: ON		0V	12V	12V	0V	0V
Measuring plate: open		12V	0V	12V	0V	0V
IG SW: ST		12V	0V	12V	12V	0V

2. If not correct, check the resistance using the ohmmeter.



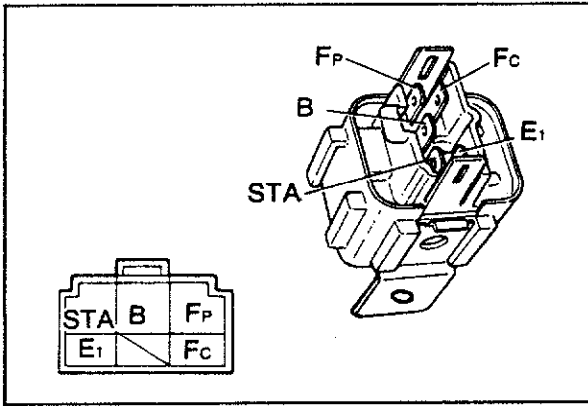

83U04A-097

**Resistance**

1. Check the resistance between the terminals using an ohmmeter.

Between terminals	Resistance ( $\Omega$ )
STA ↔ E1	15—30
B ↔ Fc	80—150
B ↔ Fp	$\infty$

2. If not correct, replace it.

## ENGINE CONTROL UNIT

### Engine Signal Monitor (49 9200 162) and Adapter (49 9200 163)

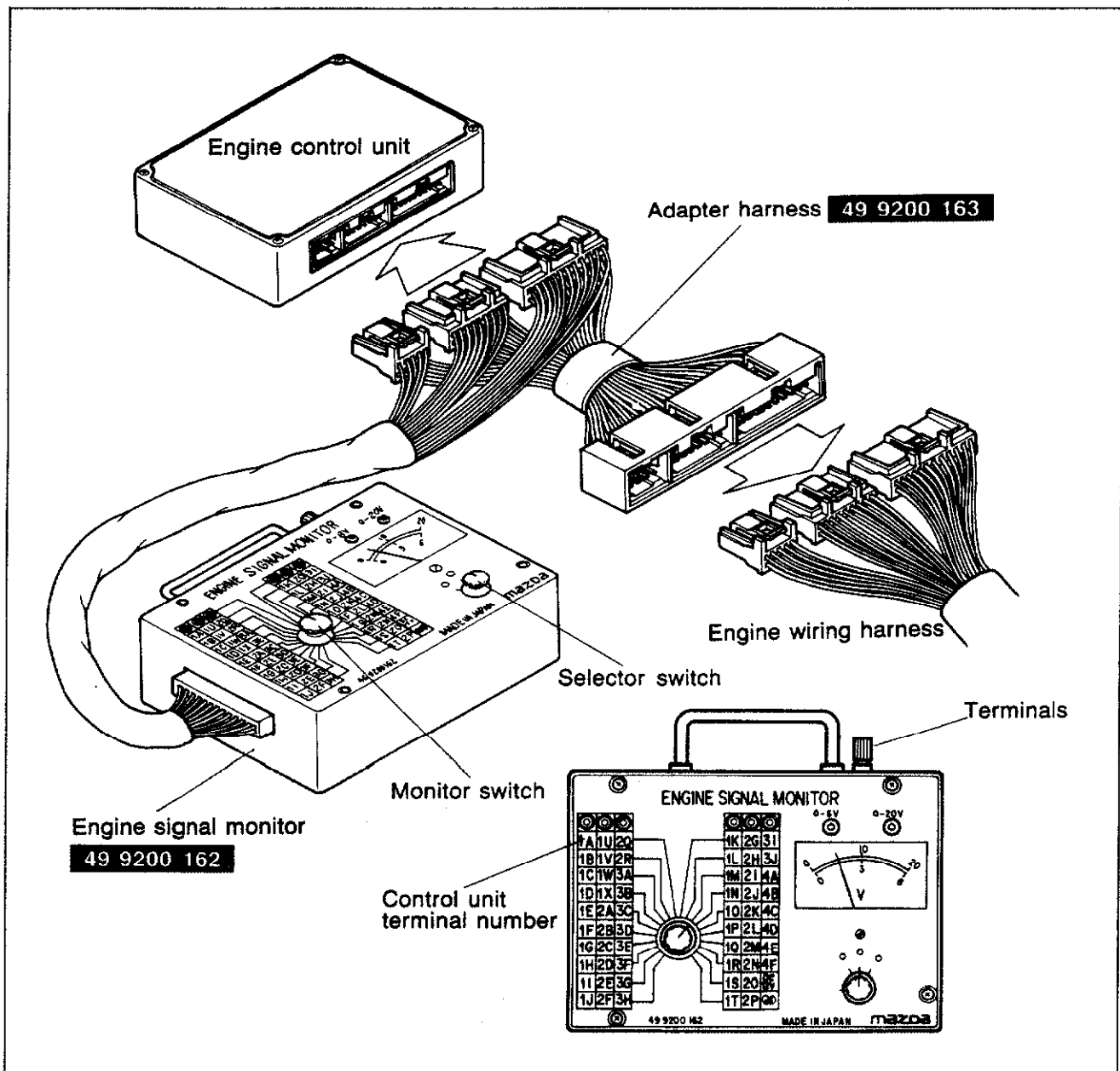

83U04A-098

The Engine Signal Monitor (49 9200 162) was developed to check the engine control unit terminal voltages. This monitor easily inspects the terminal voltage by setting the monitor switch.

#### How to Use the Engine Signal Monitor

1. Connect the **Engine Signal Monitor** (49 9200 162) between the engine control unit and the engine harness using the **adapter harness** (49 9200 163).
2. Turn the selector switch and monitor switch to select the terminal number.
3. Check the terminal voltage.

**Do not apply voltage to terminals.**

Terminal	Connected to	Voltage	Condition	Remark
1A (Output)	MIL	Below 2.5V Approx. 12V	Ignition switch OFF → ON for 3 sec. After 3 sec.	Test connector grounded
1B (Output)	Self-Diagnosis Checker (for Code No.)	Below 2.5V Approx. 12V	Ignition switch OFF → ON for 3 sec. After 3 sec.	<ul style="list-style-type: none"> <li>• Test connector grounded</li> <li>• Checker connected</li> </ul>
1C	—	—	—	—
1D (Output)	Self-Diagnosis Checker (for Monitor lamp)	Approx. 5V Approx. 10V	Ignition switch OFF → ON for 3 sec. After 3 sec.	<ul style="list-style-type: none"> <li>• Test connector grounded</li> <li>• Checker connected</li> </ul>
1E (Input)	Throttle sensor (IDL switch)	Approx. 12V Below 1.5V	Accelerator pedal depressed Accelerator pedal released	
1F (Output)	A/C control relay	Approx. 12V Below 1.5V	Ignition switch ON A/C switch ON (at idle)	
1G (Input)	Neutral/clutch switch	Approx. 12V Below 1.5V	Clutch pedal depressed Clutch pedal released	In-gear condition (Neutral: constant 12 V)
1H (Input)	Water thermo switch (Radiator)	Approx. 12V Below 1.5V	Below 17°C (63°F) Above 17°C (63°F)	
1I (Input)	Electrical load (E/L) switch	Approx. 2.5V Approx. 10V	E/L switch ON E/L switch OFF	
1J (Input)	Brake light switch	Approx. 12V Below 1.5V	Brake pedal depressed Brake pedal released	
1K (Input)	Power steering switch	Approx. 12V Below 1.5V	Power steering switch OFF Power steering switch ON	
1L (Input)	A/C switch	Approx. 12V Below 2.5V	A/C switch OFF A/C switch ON	Blower motor ON
1M (Input)	Ignition coil	Approx. 12V Approx. 12V	Ignition switch ON At idle	(When engine running) Engine Signal Monitor: Green and red light flash
1N	—	—	—	—
1O	—	—	—	—
1P	—	—	—	—
1Q	—	—	—	—
1R	—	—	—	—
1S	—	—	—	—
1T	—	—	—	—
1U (Output)	Igniter	Below 1.5V Approx. 12V	Ignition switch ON At idle	
1V (Input)	MT switch (ground)	Below 1.5V	—	ATX; constant 12V
1W (Input)	Test connector	Below 1.5V Approx. 12V	Test connector grounded Test connector not grounded	
1X	—	—	—	—
2A (Output)	Vref	4.5—5.5V	—	—
2B (Input)	Air flow meter (Vc)	7—9V	—	—
2C	Ground (E2)	Below 1.5V	—	—
2D (Input)	Oxygen sensor	0.3—0.7V More than 0.45V Less than 0.45V	At idle During acceleration During deceleration	
2E (Input)	Air flow meter (Vs)	Approx. 2V 4—5V	Ignition switch ON At idle	
2F	—	—	—	—
2G (Input)	Throttle sensor (PSW switch)	Approx. 12V Below 1.5V	Accelerator pedal released Accelerator pedal depressed (fully open throttle)	
2H (Input)	Atmospheric pressure sensor	Approx. 4V	—	At sea level
2I (Input)	Water thermo sensor	Approx. 0.5V	Normal operating temperature	
2J (Input)	Intake air thermo sensor (Air flow meter)	2—3V	Intake air temperature: 20°C (68°F)	

# 4A CONTROL SYSTEM

Terminal	Connected to	Voltage	Condition	Remark
2K (Output)	Pressure regulator control valve (PRCV) solenoid	Below 1.5V	Intake air temp. more than 58°C (136°F) Water temp. more than 90°C (194°F)	If PRCV solenoid is equipped.
		Approx. 12V	Other	
2L	---	---	---	---
2M	---	---	---	---
2N	---	---	---	---
2O	No.2 purge control solenoid	Approx. 12V	Less than 1,500 rpm	
		Below 1.5V	More than 1,500 rpm	
2P	No.1 purge control valve solenoid	Below 1.5V	Intake air temp. more than 50°C (122°F) Water temp. more than 50°C (122°F)	In-gear condition. • Jumper wire connect to the Neutral switch (MTX) • Disconnect the inhibitor switch connector (ATX)
		Approx. 12V	Other	
2Q	Idle speed control (ISC) valve	1.5—11.6V	At idle	Engine Signal Monitor: Green and red light flash
2R	Ground	Below 1.5V	---	---
3A	Ground	Below 1.5V	---	---
3B	Starter switch	Below 2.5V	Ignition switch ON	
		7—9V	While cranking	
3C	Injector No.2, No.4	Approx. 12V	At idle	Engine Signal Monitor: Green and red light flash
3D	Inhibitor switch	Below 1.5V	"N" or "P" range	MTX constant 0V
		Approx. 12V	Other range	
3E	Injector No.1 and No.3	Approx. 12V	At idle	Engine Signal Monitor: Green and red light flash
3F	---	---	---	---
3G	Ground	Below 1.5V	---	---
3H	---	---	---	---
3I	Main relay	Approx. 12V	Ignition switch ON	
3J	Battery	Approx. 12V	---	---

## Engine control unit connector

3I	3G	3E	3C	3A	2Q	2O	2M	2K	2I	2G	2E	2C	2A	1W	1U	1S	1Q	1O	1M	1K	1I	1G	1E	1C	1A
3J	3H	3F	3D	3B	2R	2P	2N	2L	2J	2H	2F	2D	2B	1X	1V	1T	1R	1P	1N	1L	1J	1H	1F	1D	1B

83U04A-099

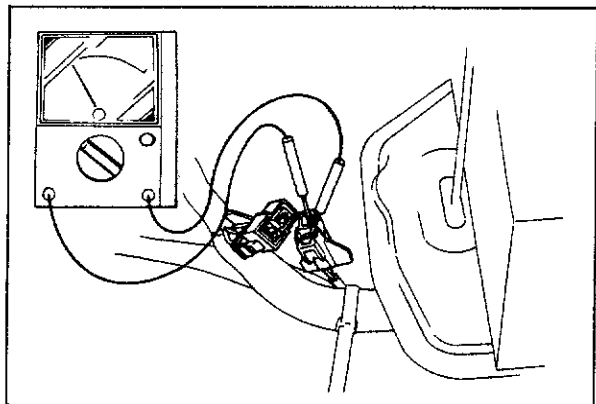

83U04A-114

## NEUTRAL SWITCH (MTX)

1. Disconnect the neutral switch connector.
2. Connect a circuit tester to the neutral switch and check the continuity between the terminals.

Condition	Continuity
In neutral	No
In other ranges	Yes

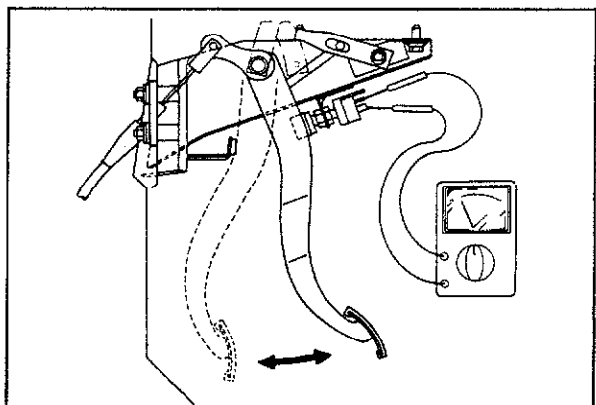

83U04A-115

## CLUTCH SWITCH (MTX)

1. Disconnect the clutch switch connector.
2. Connect the circuit tester to the clutch switch and check the continuity between the switch terminals.

Condition	Continuity
When the pedal is depressed	No
When the pedal is released	Yes

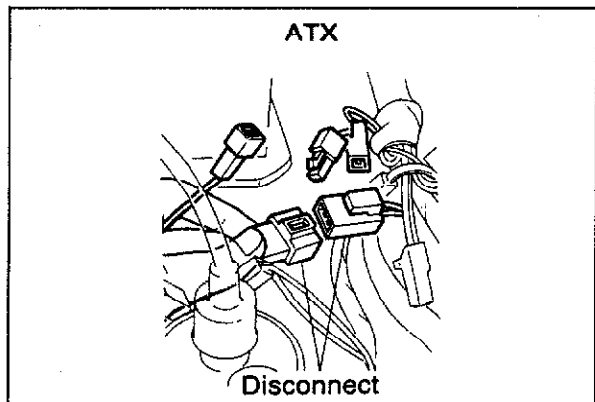

83U04A-100

## INHIBITOR SWITCH (ATX)

### Inspection

1. Disconnect the inhibitor switch connector.
2. Connect an ohmmeter to the switch.
3. Check continuity of the terminal.

Position	Continuity
P and N ranges	Yes
Other ranges	No

4. After checking, connect the switch connector.

### Note

Refer to Section 7B for replacement of the inhibitor switch.

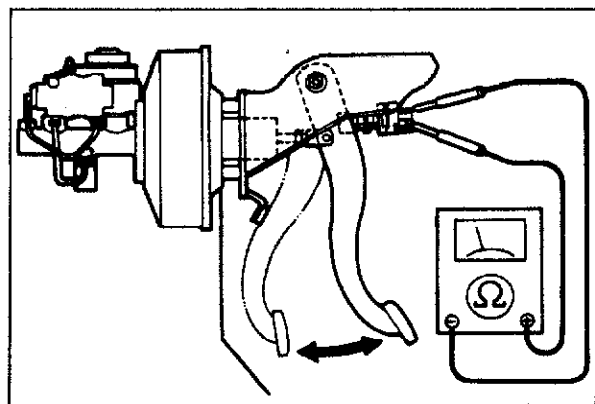

83U04A-205

## BRAKE LIGHT SWITCH

### Inspection

1. Disconnect the brake light switch connector.
2. Connect an ohmmeter to the switch.
3. Check the continuity of the switch.

Pedal	Continuity
Depressed	Yes
Released	No

4. After checking, connect the switch connector.

### Note

Refer to section 11 for replacement of the brake light switch.

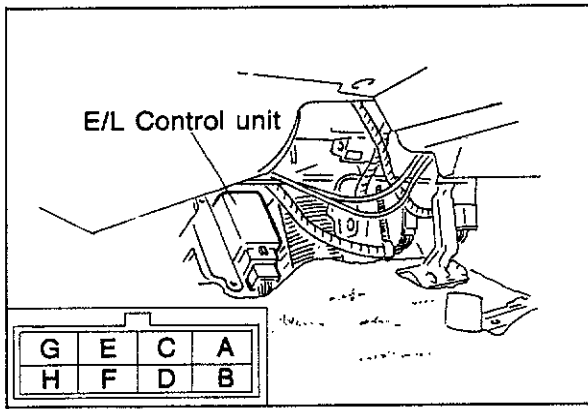

69G04A-174

## E/L CONTROL UNIT

### Inspection

1. Connect a voltmeter between the E/L control unit and ground.
2. Start the engine and check the terminal voltages as described below.

Terminal	Input	Output	Connection to	Voltage (after warm-up)	Condition
A (YG)	—	—	Main relay	Approx. 12V	
B (YG)	○		Electrical fan relay	Approx. 12V	Coolant temp.: below 97°C (206.6°F)
				Below 1.5V	Coolant temp.: above 97°C (206.6°F)
C (B)	—	—	Ground	0V	
D	—	—	—	—	—
E (L)		○	Control unit (1H)	Below 1.5V	E/L: ON
				Approx. 12V	E/L: OFF
F (RB)	○		Combination switch	Approx. 12V	Combination switch: ON
				Below 1.5V	Combination switch: OFF
G (LG)	○		Blower motor switch	Below 1.5V	Blower motor switch: ON (2nd, 3rd or 4th position)
				Approx. 12V	Others
H (BY)	○		Rear defroster switch	Below 1.5V	Rear defroster switch: ON
				Approx. 12V	Rear defroster switch: OFF

83U04A-122

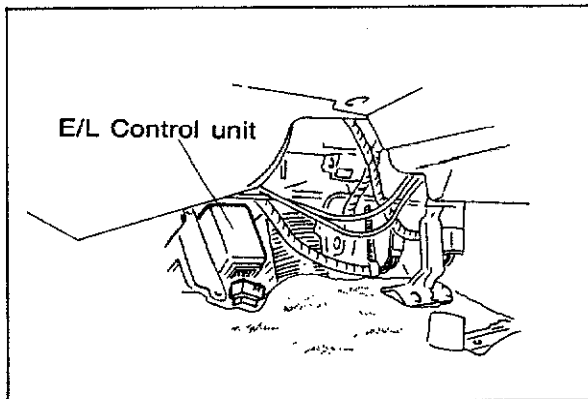

69G04A-175

### Replacement

1. Disconnect the connector from the E/L control unit.
2. Replace the E/L control unit.
3. Install in the reverse order of removal.

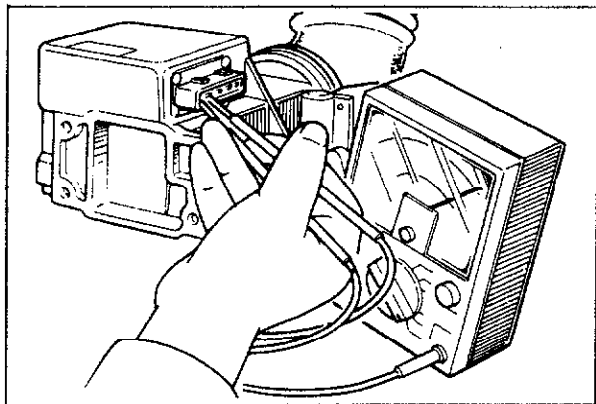

83U04A-101

## AIR FLOW METER

### Inspection

1. Inspect the air flow meter body for cracks.
2. Check the resistance between terminals using an ohmmeter.

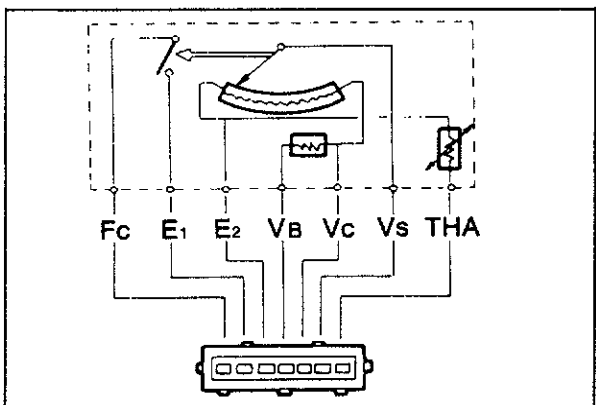

63U04B-018

Terminal	Resistance ( $\Omega$ )
E2 ↔ Vs	20 to 400
E2 ↔ Vc	100 to 300
E2 ↔ Vb	200 to 400
E2 ↔ THA (Air thermo sensor)	-20°C (-4°F) 10,000 to 20,000 0°C (32°F) 4,000 to 7,000 20°C (68°F) 2,000 to 3,000 40°C (104°F) 900 to 1,300 60°C (140°F) 400 to 700
E1 ↔ Fc	$\infty$

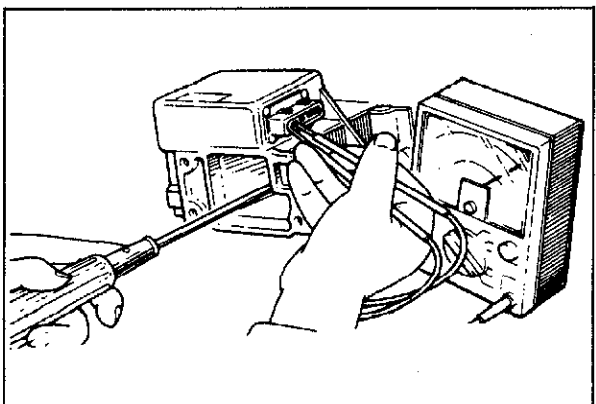

73U04B-011

3. Press open the measuring plate with a screwdriver, measure the resistance between E1 and Fc (fuel pump switch) and between E2 and Vs.

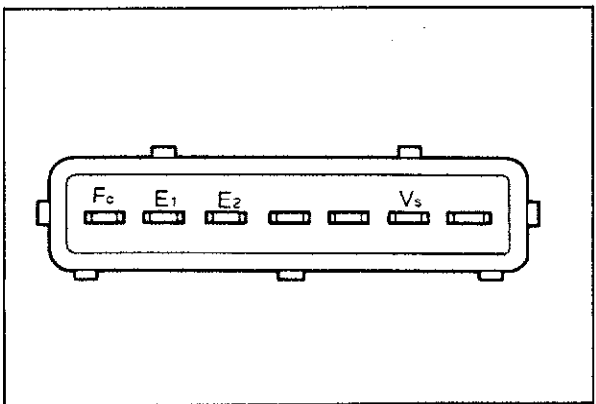

63U04B-020

Conditions Terminals	Measuring Plate	
	Fully closed	Fully open
E1 ↔ Fc	$\infty$	0
E2 ↔ Vs	20 to 400 $\Omega$	20 to 1,000 $\Omega$

4. If not correct replace it.

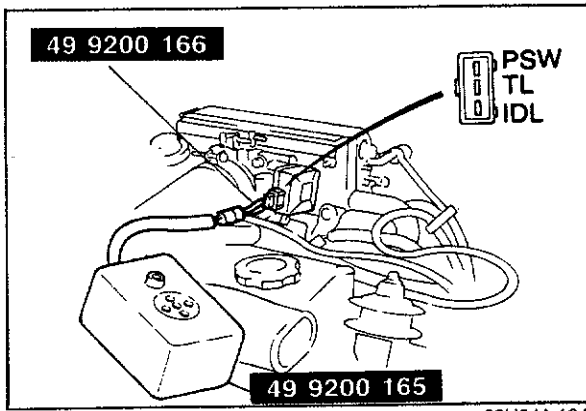

83U04A-104

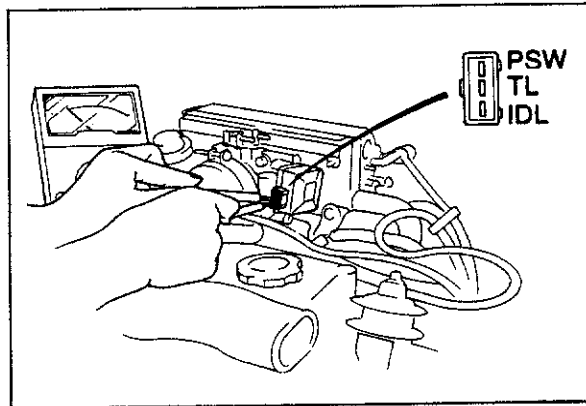

73U04B-042

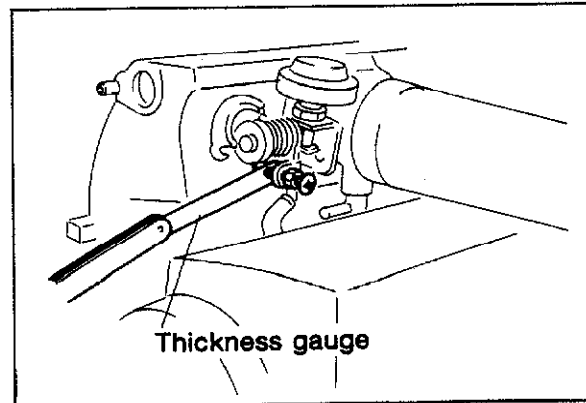

73U04B-013

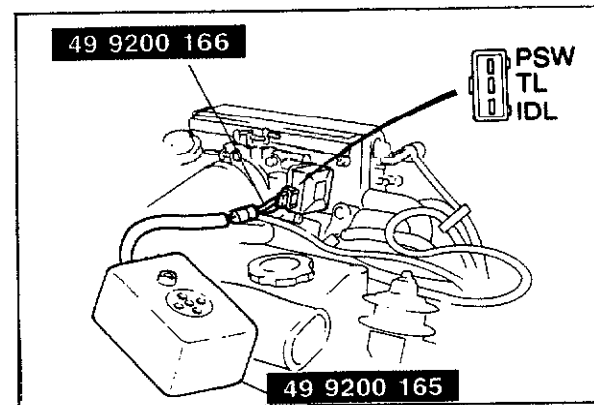

83U04A-102

## THROTTLE SENSOR

### Inspection

1. Disconnect the connector from the throttle sensor.
2. Connect the **SST** in the throttle sensor or connect an ohmmeter.

3. Insert a thickness gauge between the throttle stop screw and stop lever.
4. Note the operation of the buzzer or continuity between terminals.

Thickness gauge	Buzzing of the tester	Continuity between terminals	
		IDL ↔ TL	PSW ↔ TL
0.5 mm (0.02 in)	Yes	Yes	No
0.7 mm (0.027 in)	No	No	No
Fully open throttle lever	Yes	No	Yes

### Adjustment

1. Disconnect the connector from the throttle sensor and connect the **SST**.
2. Insert a 0.5 mm (0.020 in) thickness gauge between the throttle stop screw and stop lever.



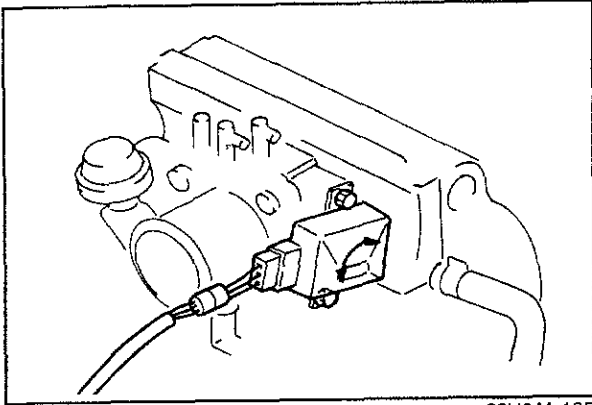

83U04A-105

3. Loosen the two attaching screws.
4. Rotate the throttle sensor clockwise about **30 degrees**, then rotate it back counterclockwise until the buzzer sounds.
5. Replace the thickness gauge with a 0.7 mm (0.027 in) gauge.
6. Check that the buzzer does not sound.
7. If it sounds, repeat steps 3 to 6.

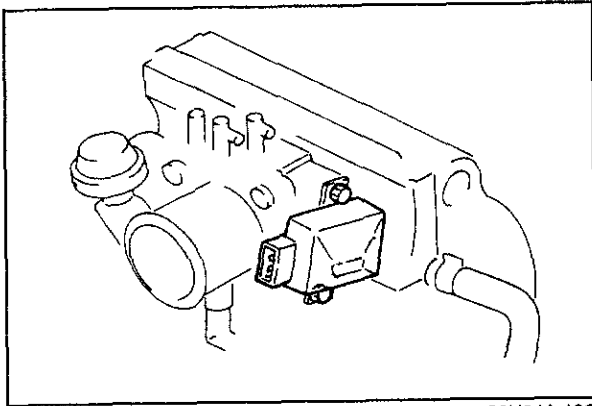

83U04A-106

8. Tighten the two attaching screws.

**Note**

**Be careful not to move the throttle sensor from the set position when tightening the screw.**

9. Open the throttle valve fully a few times, then recheck the adjustment of the throttle sensor (refer to inspection procedures).

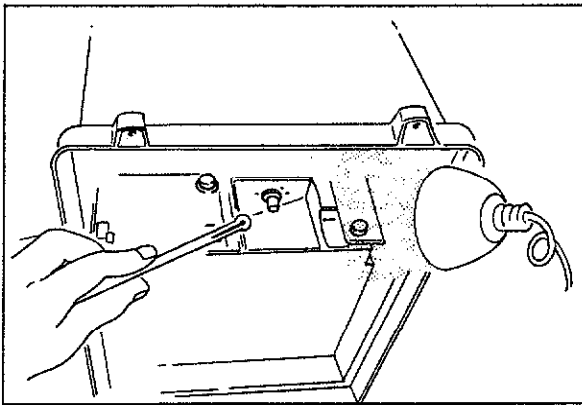

83U04A-107

## INTAKE AIR THERMO SENSOR

### Inspection of Resistance

1. Remove the air cleaner upper cover assembly.
2. Heat the intake air thermo sensor and observe the temperature.
3. Check resistance between the THA and E<sub>2</sub> terminals using an ohmmeter.

Intake Air Temperature	Resistance $\Omega$
-20°C (-4°F)	10,000—20,000 10.0—20.0
20°C (68°F)	2,000—3,000
60°C (140°F)	400—700

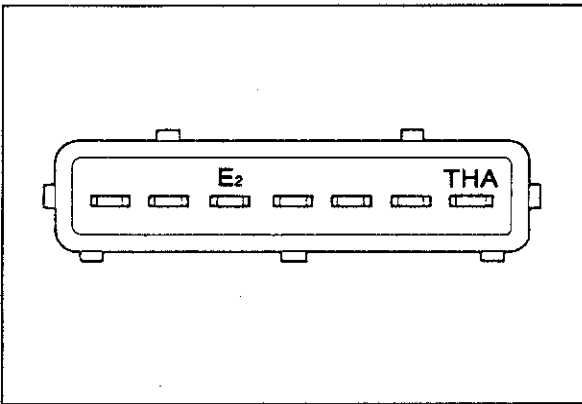

56G04B-097

4. If the resistance is not within specification, replace the air flow meter assembly.
5. If the resistance is within specification, check the wiring harnesses.

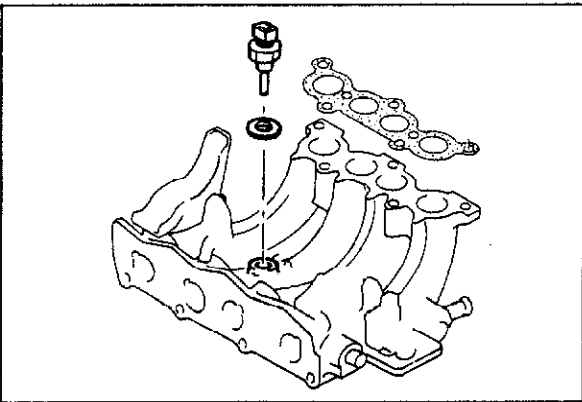

83U04A-108

## WATER THERMO SENSOR

### Inspection of Resistance

1. Remove the water thermo sensor.

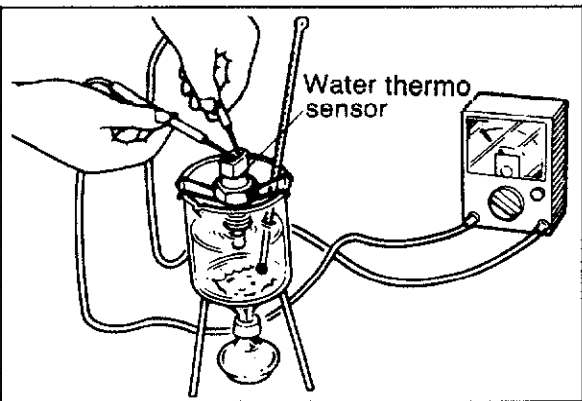

56G04B-100

2. Place the sensor in water with a thermometer and heat the water gradually.
3. Check that resistance of the sensor is within specification:

Water temperature	Resistance
-20°C (-4°F)	14.6—17.8 k $\Omega$
20°C (68°F)	2.21—2.69 k $\Omega$
80°C (176°F)	0.290—0.354 k $\Omega$

4. If not correct, replace the water thermo sensor.

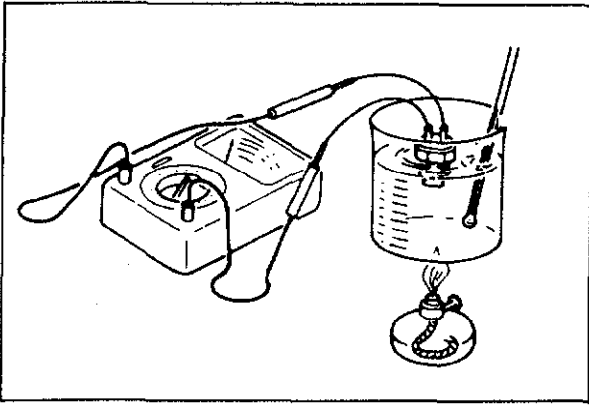

83U04A-109

## WATER THERMO SWITCH

### Inspection

1. Remove the switch from the radiator.
2. Place the switch in water with a thermometer and heat the water gradually.
3. Check that the continuity between the terminals exists at more than specification.

**Specification: 15—19°C (59—66°F)**

4. If not correct, replace the water thermo switch.

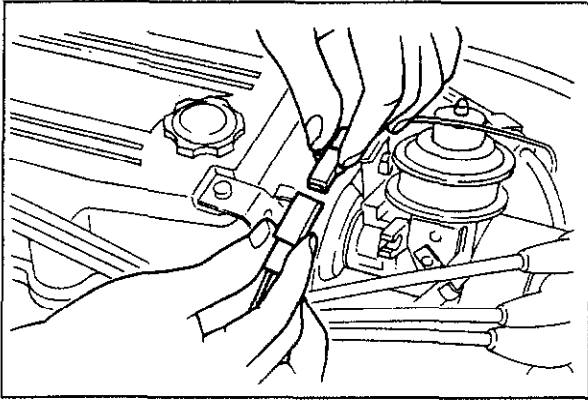

83U04A-110

## OXYGEN SENSOR

1. Warm up the engine and run it at idle speed.
2. Disconnect the oxygen sensor wiring harness connector.

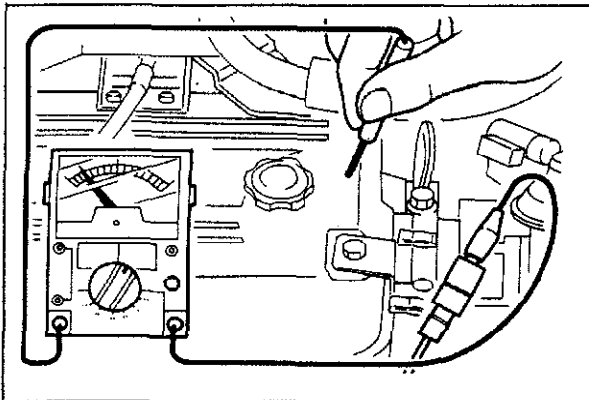

63U04B-078

3. Attach a voltmeter between the oxygen sensor connector (oxygen sensor side) and ground.
4. Run the engine at 4,000 rpm until the voltmeter indicates about **0.7V**.

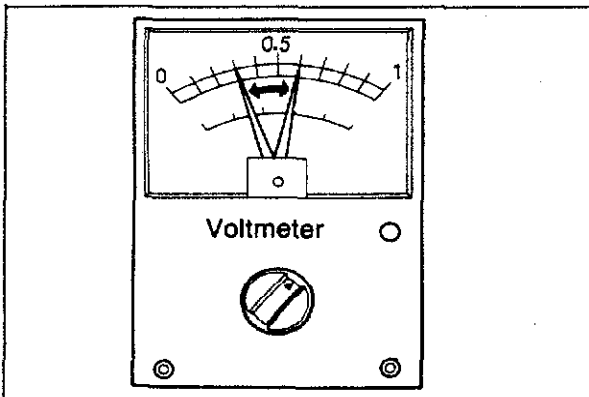

63U04B-079

5. Increase and decrease the engine speed quickly several times. When the speed is increased the meter should read between **0.5V—1.0V**. When the speed is decreased it should read between **0V—0.3V**.
6. If the voltmeter doesn't indicate above mentioned values, replace the oxygen sensor.

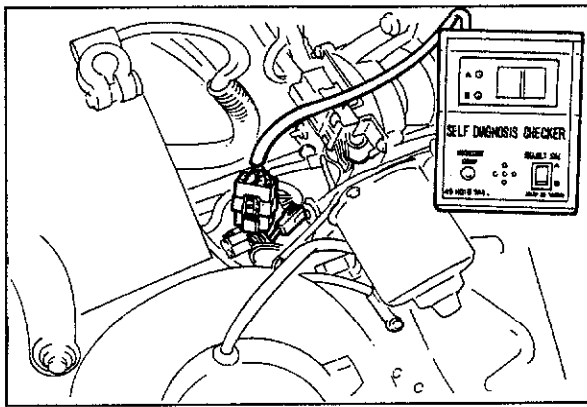

86U04A-207

## Inspection of Sensitivity

1. Warm up the engine to the normal operating temperature and run it at idle.
2. Connect the **SST** to the check connector.

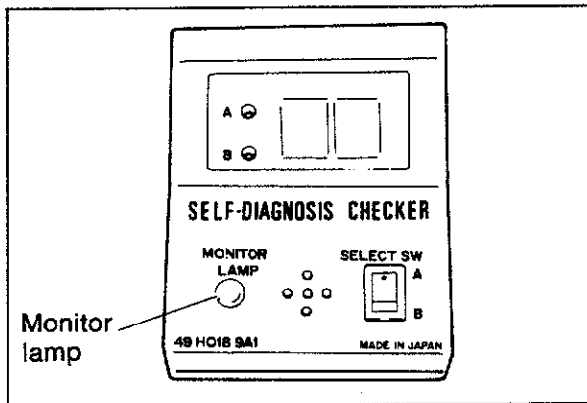

86U04A-208

3. Increase the engine speed to between **2,000 and 3,000 rpm**, and check that the monitor lamp flashes for 10 seconds.

**Monitor lamp: Flashes ON and OFF more than 8 times/10 sec**

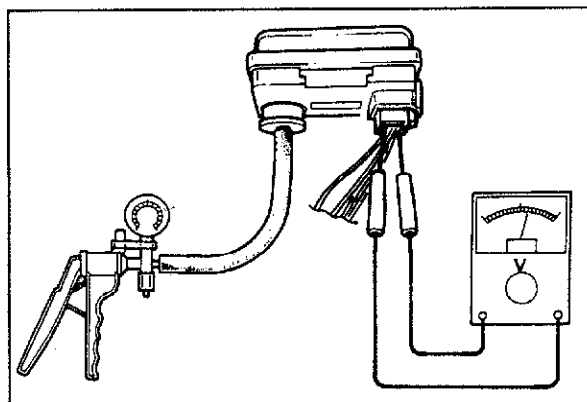

76U04A-052

## ATMOSPHERIC PRESSURE SENSOR Inspection of Terminal Voltage

1. Remove the rubber cap and connect a vacuum pump to the port of the sensor.
2. Turn the ignition switch ON.
3. Check voltage between each terminal and ground while applying and releasing vacuum to the sensor.

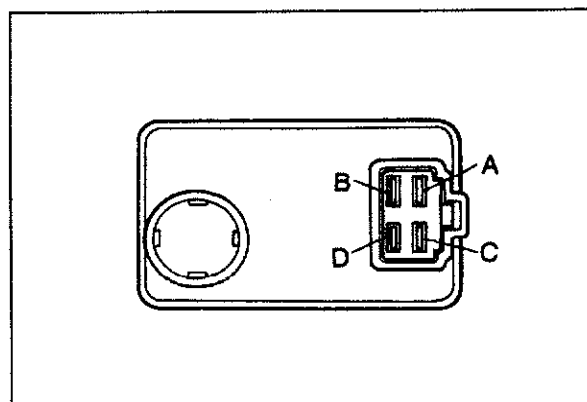

76U04A-053

Terminal (Color)	Voltage
A	—
B (Lg)	1.4—4.9V
C (LgR)	Below 1.5V
D (LgW)	4.5—5.5V

4. If the voltage at A, C or D terminal is not correct, check the wiring harness.
5. If the voltage of A, C and D terminal is OK but at B terminal is wrong, replace the atmospheric pressure switch.

# EXHAUST SYSTEM

## REMOVAL

Remove in the sequence shown in the figure.

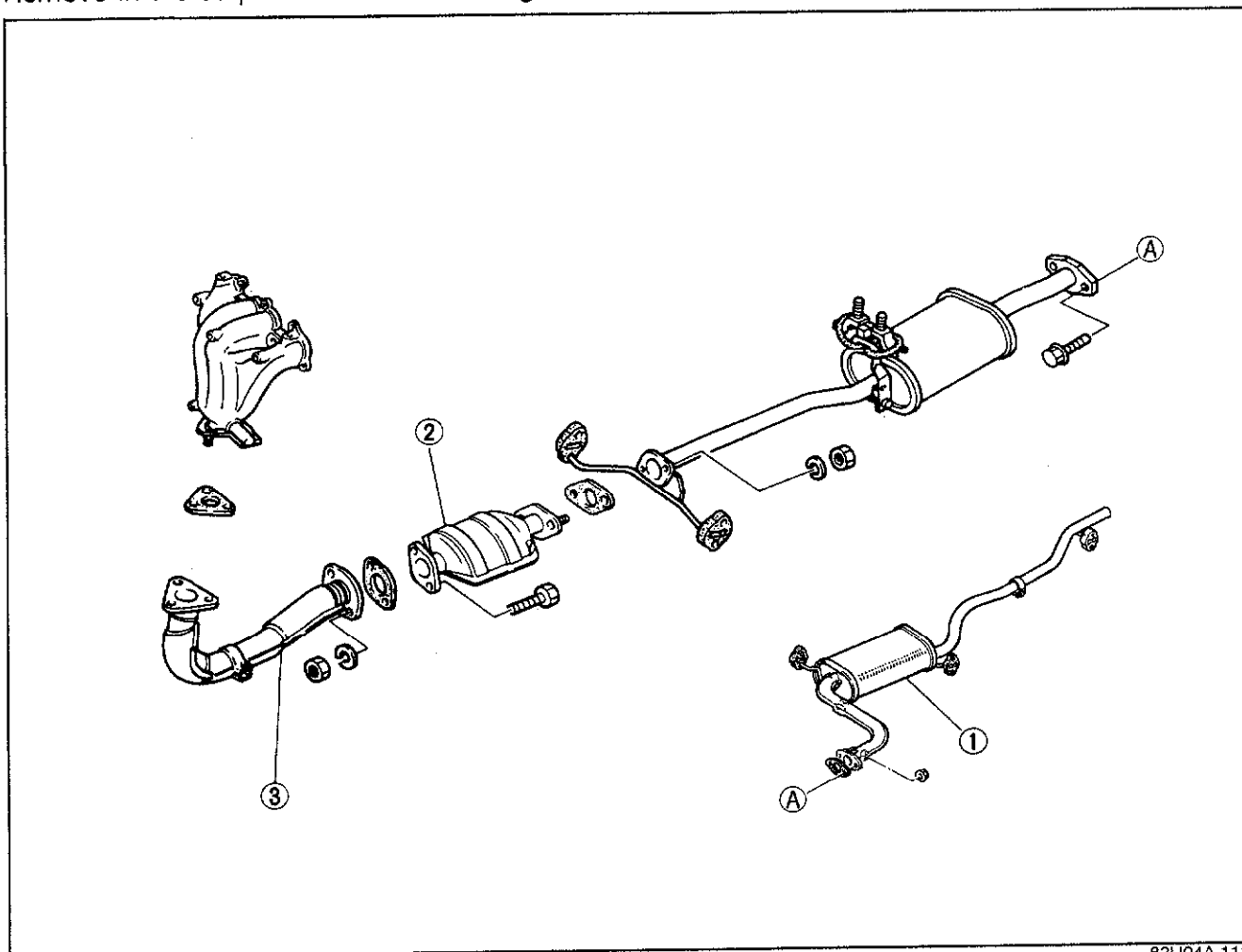

83U04A-111

- 1. Main silencer
- 2. Catalytic converter

- 3. Front exhaust pipe

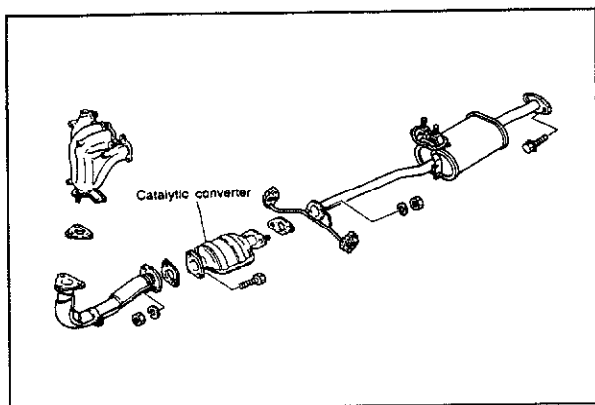

83U04A-112

## INSPECTION

Visually check the exhaust system parts for cracks, or damage.

# 4A EXHAUST SYSTEM

## INSTALLATION

Install in the reverse order of removal.

### Note

When installing the exhaust system parts, tighten to the specified torque.

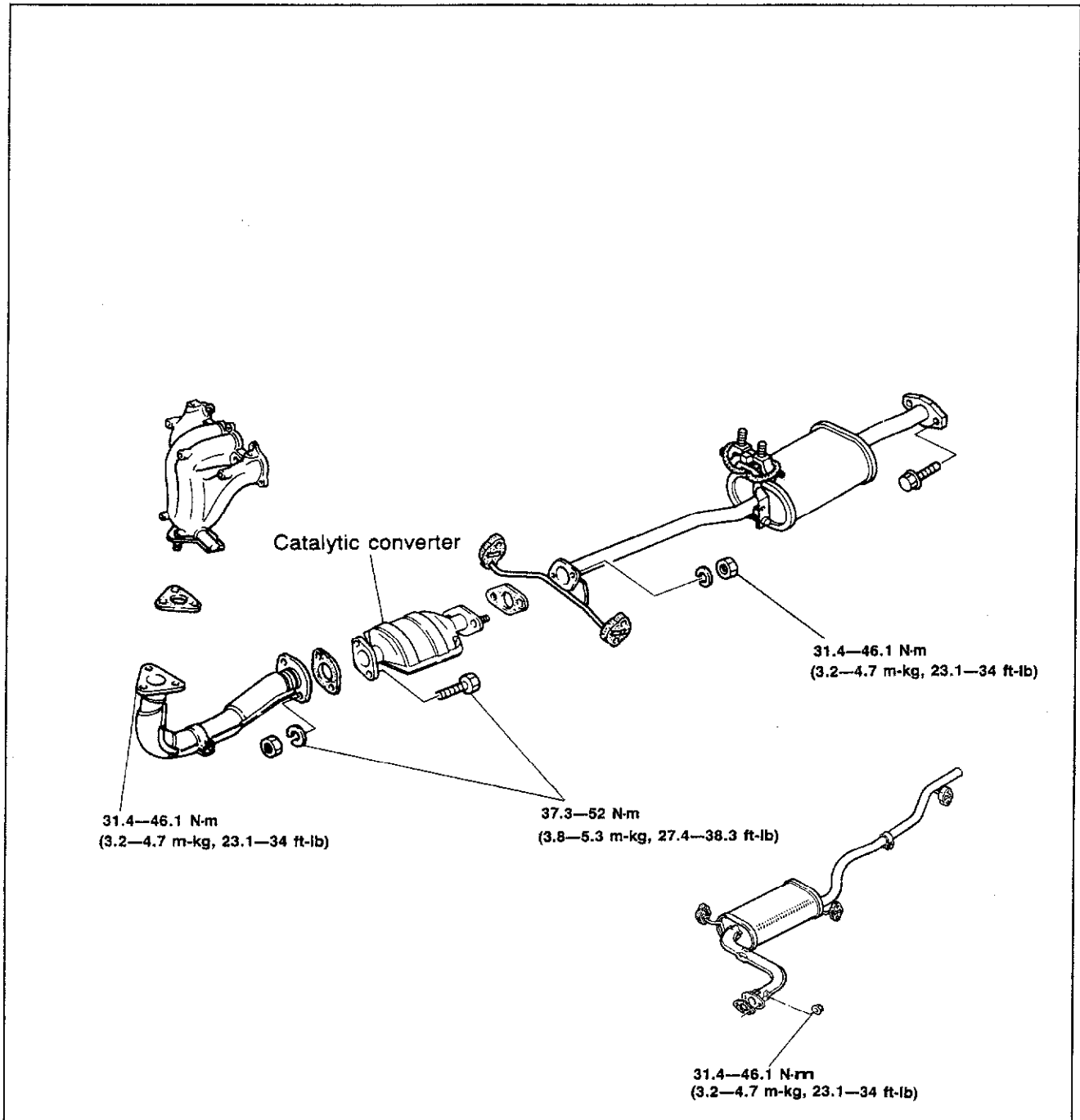

83U04A-113

# FUEL AND EMISSION CONTROL SYSTEMS (TURBO)

<b>OUTLINE</b> .....	4B- 2	<b>TURBOCHARGING SYSTEM</b> .....	4B-58
SYSTEM DIAGRAM .....	4B- 2	TROUBLESHOOTING CHART .....	4B-59
EMISSION COMPONENTS		REMOVAL AND INSTALLATION ...	4B-60
LOCATIONS .....	4B- 3	INSPECTION .....	4B-62
COMPONENT DESCRIPTIONS .....	4B- 4	<b>DECCELERATION CONTROL SYSTEM</b>	4B-64
VACUUM ROUTING DIAGRAM .....	4B- 6	TROUBLESHOOTING CHART .....	4B-65
SPECIFICATIONS .....	4B- 7	<b>EVAPORATIVE EMISSION</b>	
<b>TROUBLESHOOTING GUIDE</b> .....	4B- 8	<b>CONTROL SYSTEM</b> .....	4B-67
RELATIONSHIP CHART .....	4B- 8	SYSTEM INSPECTION .....	4B-68
TROUBLESHOOTING CHART .....	4B-10	NO.1 PURGE CONTROL VALVE ...	4B-69
<b>TROUBLESHOOTING WITH SST</b> ....	4B-12	NO.2 PURGE CONTROL VALVE ...	4B-69
INSPECTION PROCEDURE .....	4B-13	SOLENOID VALVE .....	4B-69
<b>MONITOR SWITCH FUNCTION</b> .....	4B-22	VACUUM SWITCH VALVE .....	4B-70
INSPECTION PROCEDURE .....	4B-23	THREE-WAY CHECK VALVE .....	4B-70
<b>IDLE ADJUSTMENT</b> .....	4B-26	<b>POSITIVE CRANKCASE</b>	
<b>INTAKE AIR SYSTEM</b> .....	4B-27	<b>VENTILATION (PCV) SYSTEM</b> .....	4B-71
REMOVAL AND INSTALLATION ...	4B-28	<b>CONTROL SYSTEM</b> .....	4B-72
PARTS INSPECTION .....	4B-30	MAIN FUSE .....	4B-73
AIR BYPASS VALVE .....	4B-31	MAIN RELAY .....	4B-73
INTERCOOLER .....	4B-31	CIRCUIT OPENING RELAY .....	4B-73
<b>IDLE-SPEED CONTROL (ISC)</b>		ENGINE CONTROL UNIT .....	4B-75
<b>SYSTEM</b> .....	4B-32	NEUTRAL SWITCH .....	4B-78
TROUBLESHOOTING CHART .....	4B-33	CLUTCH SWITCH .....	4B-78
<b>FUEL SYSTEM</b> .....	4B-36	BRAKE LIGHT SWITCH .....	4B-78
FUEL PRESSURE RELEASE AND		AIR FLOW METER .....	4B-79
SERVICING FUEL SYSTEM .....	4B-37	INTAKE AIR THERMO SENSOR ....	4B-79
MULTI-PRESSURE TESTER		THROTTLE SENSOR .....	4B-80
(49 9200 750A) .....	4B-38	WATER THERMO SENSOR .....	4B-82
TROUBLESHOOTING CHART .....	4B-40	WATER THERMO SWITCH .....	4B-83
FUEL PRESSURE .....	4B-41	OXYGEN SENSOR .....	4B-83
INSPECTION .....	4B-43	ATMOSPHERIC PRESSURE	
TRANSFER PUMP CONTROL		SENSOR .....	4B-84
SYSTEM .....	4B-44	ELECTRICAL LOAD (E/L)	
REPLACEMENT AND		CONTROL UNIT .....	4B-85
INSTALLATION .....	4B-49	<b>EXHAUST SYSTEM</b> .....	4B-86
FUEL TANK (2WD) .....	4B-52	REMOVAL .....	4B-86
FUEL TANK (4WD) .....	4B-53	INSPECTION .....	4B-86
<b>PRESSURE REGULATOR CONTROL</b>		INSTALLATION .....	4B-87
<b>(PRC) SYSTEM</b> .....	4B-54	<b>TROUBLESHOOTING WITH MIL</b>	
		<b>(MALFUNCTION INDICATOR</b>	
		<b>LIGHT)</b> .....	4B-88

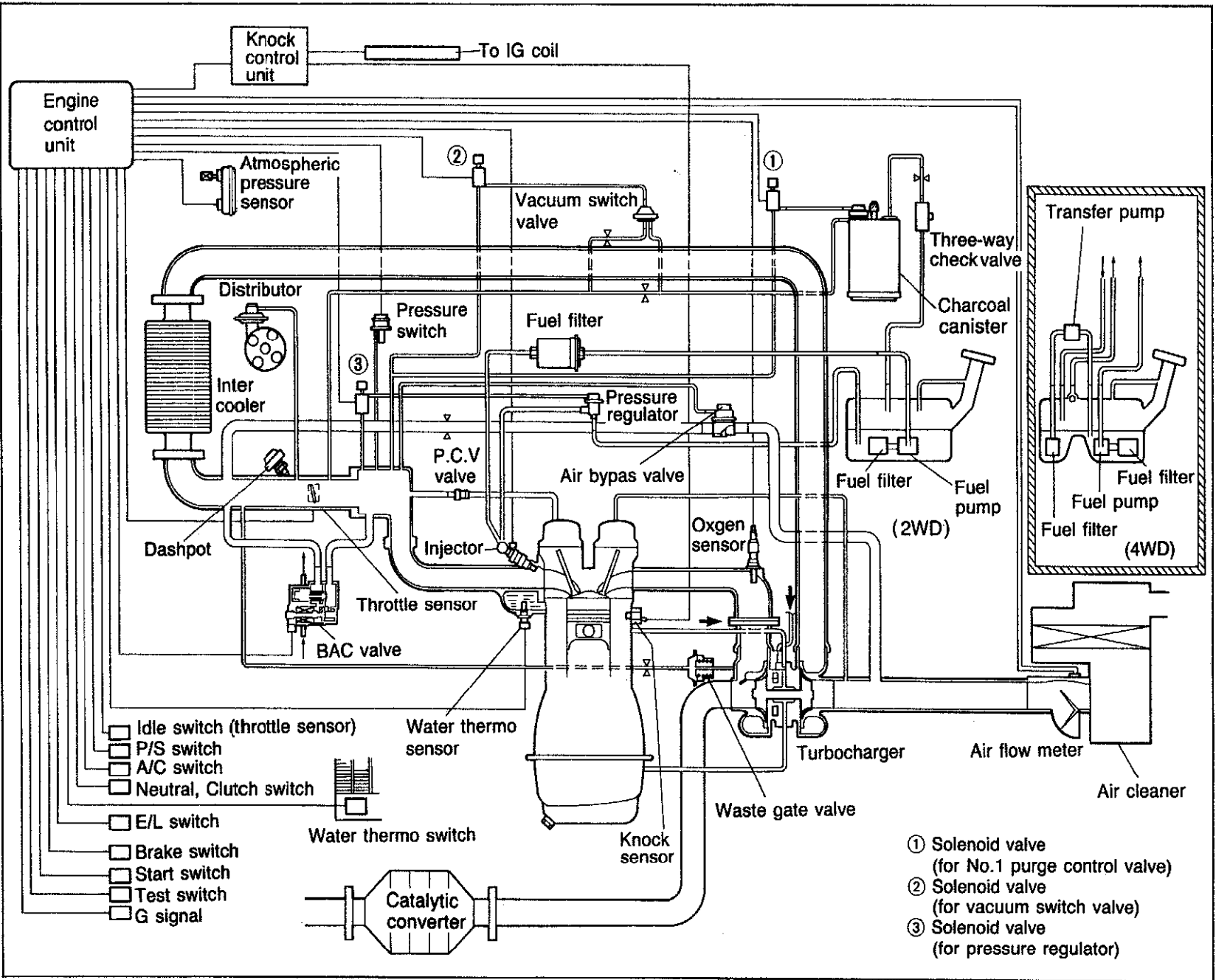



EMISSION COMPONENT LOCATION

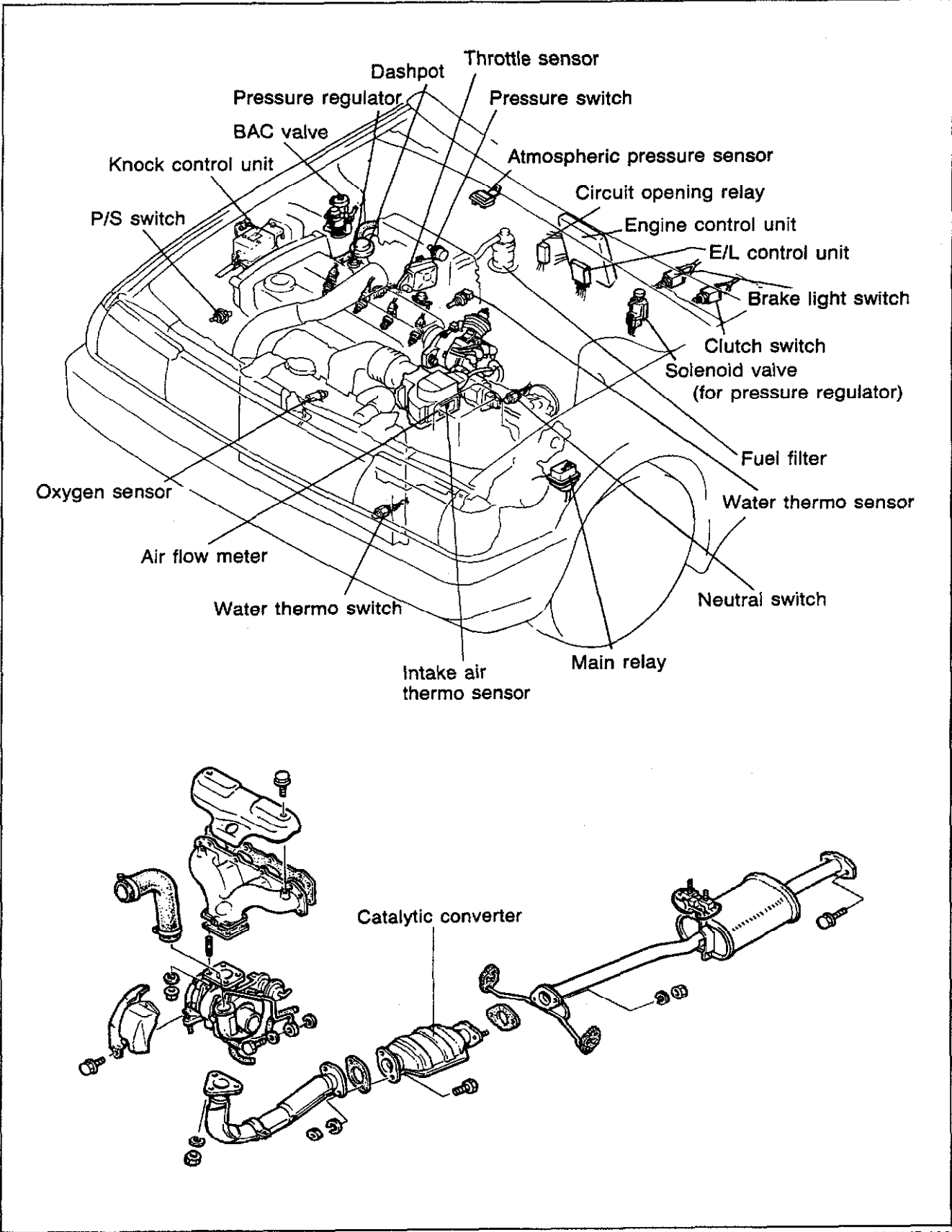

## COMPONENT DESCRIPTIONS

No.	COMPONENT	FUNCTION	REMARKS
1	Air cleaner	Filters air into the combustion chamber	
2	Air flow meter	Detects intake air amount; sends signal to the engine control unit. (for determination of fuel injection amount)	Intake air thermo sensor and fuel pump switch are integrated.
3	Atmospheric pressure sensor	Detects atmospheric pressure to prevent over rich mixture; sends signal to engine control unit.	
4	Air valve	When engine is cold, supplies bypass air into dynamic chamber for quick warm-up and smooth idle.	<ul style="list-style-type: none"> <li>• Thermo wax type</li> <li>• Installed into BAC valve</li> </ul>
5	Brake light switch	Detects brake operation (deceleration); sends signal to control unit.	
6	Catalytic converter	Reduce HC and CO by oxidation. Reduce NOx.	Honeycomb construction
7	Charcoal canister	Stores fuel tank fumes while engine is stopped for evaporative emission.	
8	Check connector	For Self-diagnosis checker	6 pin connector (Green)
9	Circuit opening relay	Supplies voltage for fuel pump while engine running.	
10	Clutch switch	Detects in-gear condition; sends signal to control unit.	Switch closed when clutch pedal is released.
11	Engine control unit	<p>Detects the following;</p> <ol style="list-style-type: none"> <li>1. Engine speed</li> <li>2. Intake air amount</li> <li>3. Engine coolant temperature</li> <li>4. Engine load condition</li> <li>5. Oxygen concentration</li> <li>6. In-gear condition</li> <li>7. Intake air temperature</li> </ol> <p>8. Atmospheric pressure 9. A/C operation 10. P/S operation 11. E/L operation 12. Starting signal 13. Initial set signal</p> <p>Controls operation of the following;</p> <ol style="list-style-type: none"> <li>1. Fuel injection amount</li> <li>2. Idle speed control system</li> <li>3. Pressure regulator control system</li> <li>4. Fail-safe system</li> <li>5. Monitor switch function</li> </ol>	<ol style="list-style-type: none"> <li>1. Ignition coil (-) terminal</li> <li>2. Air flow meter</li> <li>3. Water thermo sensor</li> <li>4. Throttle sensor (Point type)</li> <li>5. Oxygen sensor</li> <li>6. Clutch switch and neutral switch</li> <li>7. Intake air thermo sensor (in air flow meter)</li> <li>8. Atmospheric pressure sensor</li> <li>9. A/C switch</li> <li>10. P/S switch</li> <li>11. E/L switch</li> <li>12. Starter switch (Ignition switch)</li> <li>13. Test terminal</li> </ol> <ol style="list-style-type: none"> <li>1. Injector</li> <li>2. BAC valve</li> <li>3. Solenoid valve (for pressure regulator)</li> <li>4. Self-diagnosis checker and MIL</li> <li>5. Monitor lamp (Self-diagnosis checker)</li> </ol>
12	Dashpot	Gradually allows throttle valve closing during deceleration.	Adjustment speed MTX....2,000 ± 150 rpm
13	Fuel filter	Filters particles from fuel	
14	Fuel pump	Provides fuel to injectors	<ul style="list-style-type: none"> <li>• Operates while engine is running</li> <li>• Installed in fuel tank</li> </ul>
15	Injector	Injects fuel to intake port	Controlled by signals from engine control unit.
16	Intake Air Thermo Sensor	Detects intake air temperature; compensates fuel injection amount through engine control unit.	Thermistor
17	Intercooler	Cools intake air temperature after turbocharger	Air cooled

No.	COMPONENT	FUNCTION	REMARKS
18	Intank Filter	Filters particles from fuel	Installed in low-pressure side
19	ISC valve	Supplies bypass air to intake manifold assembly for smooth idle	Installed into BAC valve
20	Neutral switch	Detects transaxle condition; sends signal to control unit	
21	Oxygen Sensor	Detects oxygen concentration in exhaust gas; sends signal to engine control unit; compensates fuel injection amount	Zirconia ceramic with platinum coating
22	Pressure Regulator	Regulates fuel pressure to injectors	
23	Pressure Switch (For Overboost Detection)	Detects overboost condition; sends signal to engine control unit	
24	No.1 Purge Control Valve	Open and closes evaporative vapor passage from canister to intake manifold	During open throttle
25	No.2 Purge Control Valve	Positive pressure and negative pressure valves operate in accordance with fuel tank pressure	Prevents canister from flooding
26	Throttle Sensor (Variable resistor type)	Detects throttle opening angle; sends signal to control unit; compensates fuel injection amount	
27	Solenoid Valve (for No.1 purge control valve)	Opens and closes vacuum passage to No.1 purge control valve	Controlled by signal from engine control unit
	Solenoid Valve (for vacuum switch valve)	Opens and closes vacuum passage to vacuum switch valve	Controlled by signal from engine control unit
	Solenoid valve (for pressure regulator)	Closes vacuum passage between dynamic chamber and pressure regulator	Only during hot condition
28	Transfer Pump	Pumps fuel from one side of tank to other to maintain balance	
29	Turbocharger	Pressurizes intake air utilizing exhaust gas flow	Water cooled
30	Vacuum Switch Valve	Opens passage of vacuum line when vacuum applied	Vacuum from three-way solenoid valve
31	Water Thermo Sensor	Detects coolant temperature; sends signal to control unit; compensates fuel injection amount	Thermistor
32	Water Thermo Switch	Detects radiator coolant temperature; sends signal to control unit; increases fuel injection amount	Above 17°C (63°F): ON
33	Waste Gate Valve	Allows bypassing of exhaust gas to control turbocharger boost pressure	

83U04B-005

## VACUUM ROUTING DIAGRAM

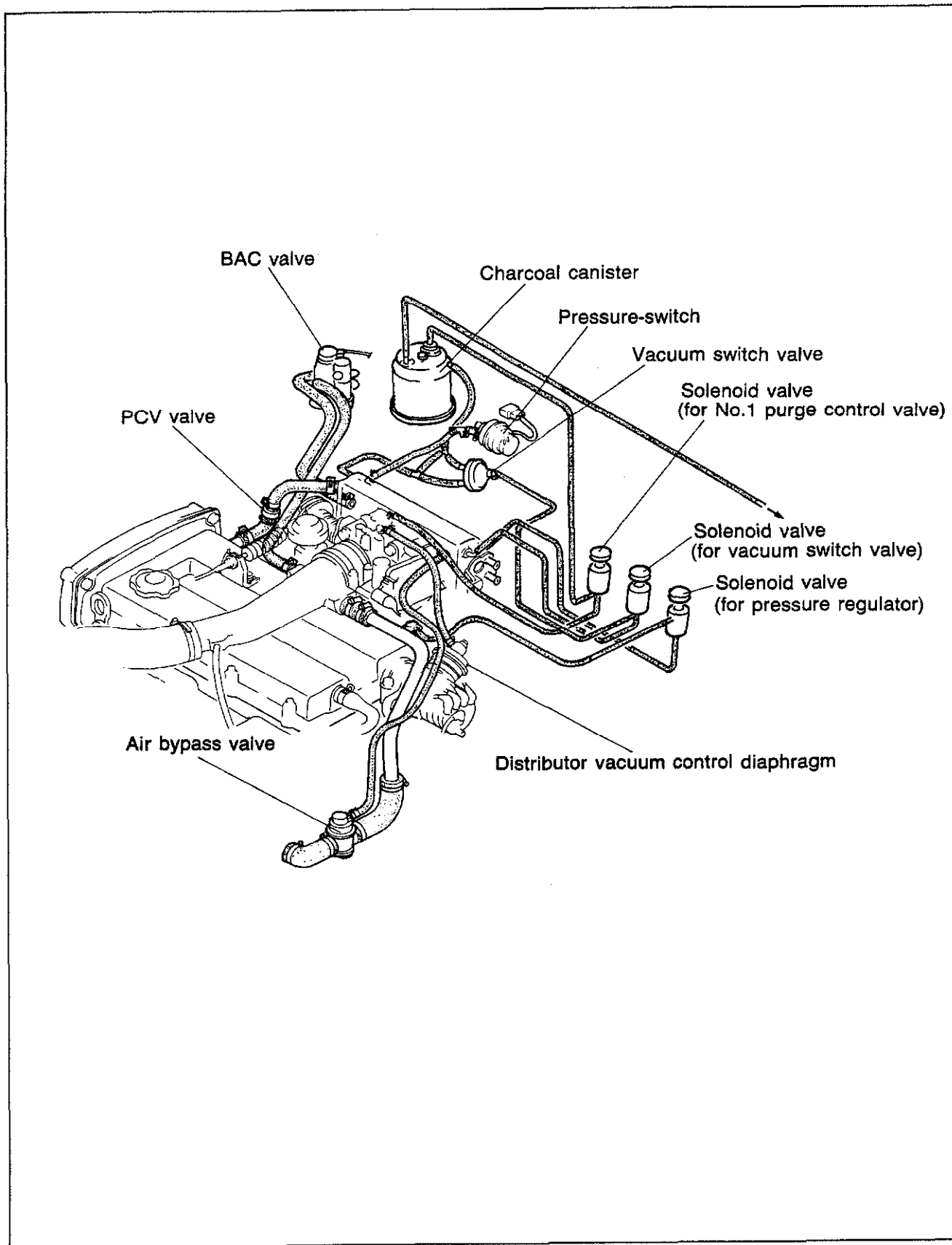

83U04B-005

**SPECIFICATIONS**

Item		Engine model	Turbo
Idle-speed rpm			850 ± 50 in Neutral
<b>Throttle body</b>			
Type			Horizontal draft (1-barrel)
Throat diameter		mm (in)	50 (1.968)
<b>Air flow meter</b>			
Resistance	Ω	E2—Vs	Fully closed: 20—400 Fully open: 20—1,000
		E2—Vc	100—300
		E2—VB	200—400
		E2—THA	-20°C (-4°F) 10,000—20,000 20°C ( 68°F) 2,000—3,000 60°C (140°F) 400—700
<b>Fuel pump</b>			
Type			Impeller (in tank)
Output pressure		kPa (kg/cm <sup>2</sup> , psi)	441—588 (4.5—6.0, 64—85)
Feeding capacity		cc (cu in)/10 sec.	220—380 (13.4—23.2) when fuel pressure is at 250 kPa
<b>Transfer pump</b>			
Feeding capacity		cc (cu in)/10 sec.	278—388 (16.95—23.7)
<b>Pressure regulator</b>			
Type			Diaphragm
Regulating pressure		kPa (kg/cm <sup>2</sup> , psi)	240—279 (2.45—2.85, 34.8—40.5)
<b>Fuel filter</b>			
Type	Low-pressure side		Nylon 6 (250 mesh) element
	High-pressure side		Paper element
<b>Injector</b>			
Type			High-ohmic
Type of drive			Voltage
Resistance		Ω	12—16
Injection amount		cc (cu in)/15 sec	66—82 (4.0—5.0)
<b>Turbocharger</b>			
Type			Water cooled
Lubrication			Engine oil
Boost pressure (Max)		kPa (kg/cm <sup>2</sup> , psi)	55—64 (0.56—0.65, 8.0—9.2)
<b>Waste-gate valve</b>			
Operating pressure		kPa (kg/cm <sup>2</sup> , psi)	48.1—58.9 (0.49—0.60, 7.0—8.6)
<b>Idle-speed control valve</b>			
Solenoid resistance		Ω	5—20
<b>Fuel tank</b>			
Capacity		liters (US gal, Imp gal)	50 (13, 11)
<b>Air cleaner</b>			
Element type			Wet
<b>Accelerator cable</b>			
Free play		mm (in)	1—3 (0.039—0.118)
<b>Fuel</b>			
Specification			Unleaded gasoline

83U04B-006

## TROUBLESHOOTING GUIDE

### RELATIONSHIP CHART

#### Input Devices and Output Devices

OUTPUT DEVICE  INPUT DEVICE	INJECTOR		PRCV SOLENOID	BAC VALVE		PURGE SOLENOID	
	FUEL IN- JECTION AMOUNT	FUEL IN- JECTION TIMING		AIR VALVE	ISC VALVE	No.1	No.2
IGNITION COIL	○	○	X	X	○	X	○
AIR FLOW METER	○	X	X	X	X	X	○
IDLE SWITCH	○	X	○	X	○	X	X
THROTTLE SENSOR	○	X	X	X	X	X	X
WATER THERMO SENSOR	○	X	○	X	○	○	X
INTAKE AIR THERMO SENSOR	○	X	○	X	○	○	X
ATMOSPHER- IC PRESSURE SENSOR	○	X	X	X	○	X	X
OXYGEN SENSOR	○	X	X	X	○	○	X
PRESSURE SWITCH	○	X	X	X	X	X	X
BRAKE LIGHT SWITCH	○	X	X	X	X	X	X
WATER THERMO SWITCH	○	X	X	X	○	○	X
NEUTRAL AND CLUTCH SWITCH	○	X	○	X	○	○	X
START SWITCH	○	○	○	X	X	X	X
FF SWITCH	○	X	X	X	X	X	X
A/C SWITCH	X	X	X	X	○	X	X
P/S SWITCH	X	X	X	X	○	X	X
G SENSOR	X	○	X	X	X	X	X
TEST CONNECTOR	X	X	X	X	○	X	X

83U04B-007

Output Devices and Engine Conditions (Turbocharged Engine)

ENGINE CONDITION OUTPUT DEVICES		CRANKING (COLD ENGINE)	WARMING UP (DURING IDLE)	MEDIUM LOAD		ACCELERATION	HEAVY LOAD	DECELERATION	IDLE (THROTTLE VALVE FULLY CLOSED)	IGN: ON (ENGINE NOT RUNNING)	REMARKS
				COLD	WARM						
INJECTOR	INJECTION	Rich		Rich and Lean	Rich		Fuel Cut	Rich	Does not inject	Above 6,800 rpm fuel cut	
	INJECTION TIMING	1 Group	2 Group			2 Group					
PRCV SOLENOID		ON (Vacuum cut)	OFF (Vacuum to pressure regulator)					* After start ON (Vacuum cut)	Does not operate	* During hot starting	
BAC VALVE	AIR VALVE	* Open		Close					* Coolant temp: below 60°C (140°F)		
	ISC VALVE	Large amount of bypass air		Small amount of bypass air			* Large and small amount of bypass air	Does not operate	* Test connector grounded: small amount		
PURGE SOLE- N- VID	No.1	OFF (Vacuum cut)		* ON (Vacuum to No.1 purge control valve)			OFF (Vacuum cut)		* Positive pressure: OFF		
	No.2	OFF (Vacuum cut)		* ON (Vacuum to vacuum switch valve)			OFF (Vacuum cut)		* Engine speed: above 1,500 rpm		

## TROUBLESHOOTING CHART

POSSIBLE CAUSE		INPUT DEVICES									OUTPUT DEVICES																				
		Ignition coil	Group sensor (Distributor)	Air flow meter	Water thermo sensor	Intake air thermo sensor (in Air flow meter)	Throttle sensor (Variable resistor type)	Atmospheric pressure sensor	Oxygen sensor	Feedback system	Solenoid valve (Pressure regulator)	Solenoid valve (No.1 purge control valve)	Solenoid valve (Vacuum switch valve)	BAC Valve (Idle speed control valve)																	
SYMPTOM		4B-14	4B-14	4B-15	4B-16	4B-17	4B-18	4B-19	4B-20	4B-20		4B-21	4B-21	4B-21	4B-21																
1	Front indicated by SST Code NO.	01	03	08	09	10	12	14	15	17		25	26	27	34																
2	Hard start or won't start (Crank: OK)	<p><b>TROUBLESHOOTING PROCEDURE:</b></p> <p><b>Note</b> Step 1 under symptom is to quickly determine what system or parts may be at fault using the self-Diagnosis Checker (49 H018 9A1)</p> <p><b>1st</b> Check input sensors and switches and output solenoid valves self-diagnosed with <b>Self-Diagnosis checker</b> (Refer to page 4B-12).</p> <p><b>2nd</b> Check other switches with <b>Self-Diagnosis Chicker</b> (Refer to page 4B-22).</p> <p><b>3rd</b> Check the following items:</p> <table border="0"> <tr> <td><b>Electrical system</b></td> <td><b>Ignition system</b></td> </tr> <tr> <td>1) Battery condition</td> <td>1) Spark plugs</td> </tr> <tr> <td>2) Fuses</td> <td>2) Ignition timing</td> </tr> <tr> <td><b>Fuel system</b></td> <td><b>Intake air system</b></td> </tr> <tr> <td>1) Fuel amount</td> <td>1) Air cleaner element</td> </tr> <tr> <td>2) Fuel leakage</td> <td>2) Vacuum or air leakage</td> </tr> <tr> <td>3) Fuel filter</td> <td>3) Vacuum hose routing</td> </tr> <tr> <td>4) Idle speed</td> <td>4) Accelerator cable</td> </tr> </table> <p><b>4th</b> Check the Fuel and Emission Control Systems</p>														<b>Electrical system</b>	<b>Ignition system</b>	1) Battery condition	1) Spark plugs	2) Fuses	2) Ignition timing	<b>Fuel system</b>	<b>Intake air system</b>	1) Fuel amount	1) Air cleaner element	2) Fuel leakage	2) Vacuum or air leakage	3) Fuel filter	3) Vacuum hose routing	4) Idle speed	4) Accelerator cable
<b>Electrical system</b>	<b>Ignition system</b>																														
1) Battery condition	1) Spark plugs																														
2) Fuses	2) Ignition timing																														
<b>Fuel system</b>	<b>Intake air system</b>																														
1) Fuel amount	1) Air cleaner element																														
2) Fuel leakage	2) Vacuum or air leakage																														
3) Fuel filter	3) Vacuum hose routing																														
4) Idle speed	4) Accelerator cable																														
3	Engine stall															Only while warming up															
																Only after warming up															
4	Rough idle															Only while warming up															
																Only after warming up															
5	High idle speed after warming up																														
6	Poor acceleration, hesitation, or lack of power																														
7	Runs rough on deceleration																														
8	Knocking																														
9	Excessive fuel consumption																														
10	Abnormal noise																														
11	Vibration																														
12	White smoke																														
13	Excessive oil consumption																														
14	Afterburn in exhaust system																														
15	Engine stalls or rough after hot starting																														
16	Fail emission test																														

83U04B-009



	<b>POSSIBLE CAUSE</b>										
	Intake air system (Poor connection of components, throttle body)	Fuel system (Fuel injection, fuel pressure)	ISC (Idle speed control) system (Air valve, ISC solenoid valve)	PRC (Pressure regulator control) system	Turbocharging system (Oil and water passage, turbine, and compressor wheels malfunction)	PCV (Positive crank case ventilation) system	Knock control system	Evaporative emission control system (Vacuum switch valve, No.1, No.2 purge valve malfunction)	Deceleration system (Fuel cut operation malfunction)	Exhaust system (System clogged)	
	<b>PAGE</b>	<b>4B-27</b>	<b>4B-37</b>	<b>4B-32</b>	<b>4B-54</b>	<b>4B-58</b>	<b>4B-71</b>	<b>5-41</b>	<b>4B-67</b>	<b>4B-64</b>	<b>4B-86</b>
<b>SYMPTOM</b>	<b>2</b>	2	1								
	<b>3</b>	3	2	1							
		4	3	2			1				
	<b>4</b>	4	3	1			2				
		5	4	2			1		3		
	<b>5</b>	2		1							
	<b>6</b>	2	3			5			1		4
	<b>7</b>		3	2						1	
	<b>8</b>					2		1			
	<b>9</b>		2							1	3
	<b>10</b>					1					
	<b>11</b>					1					
	<b>12</b>					1					
	<b>13</b>					1					
	<b>14</b>	3	4	1						2	
	<b>15</b>		2			1					
	<b>16</b>	5	6	3					4	2	1

83U04B-010

The number of the list show the priorities of inspections from the most possible to that with the lowest possibility.

These were determined on the following basis:

- Ease of inspection
- Most possible system
- Most possible point in the system

## TROUBLESHOOTING WITH SST

### SELF-DIAGNOSIS CHECKER (49 H018 9A1)

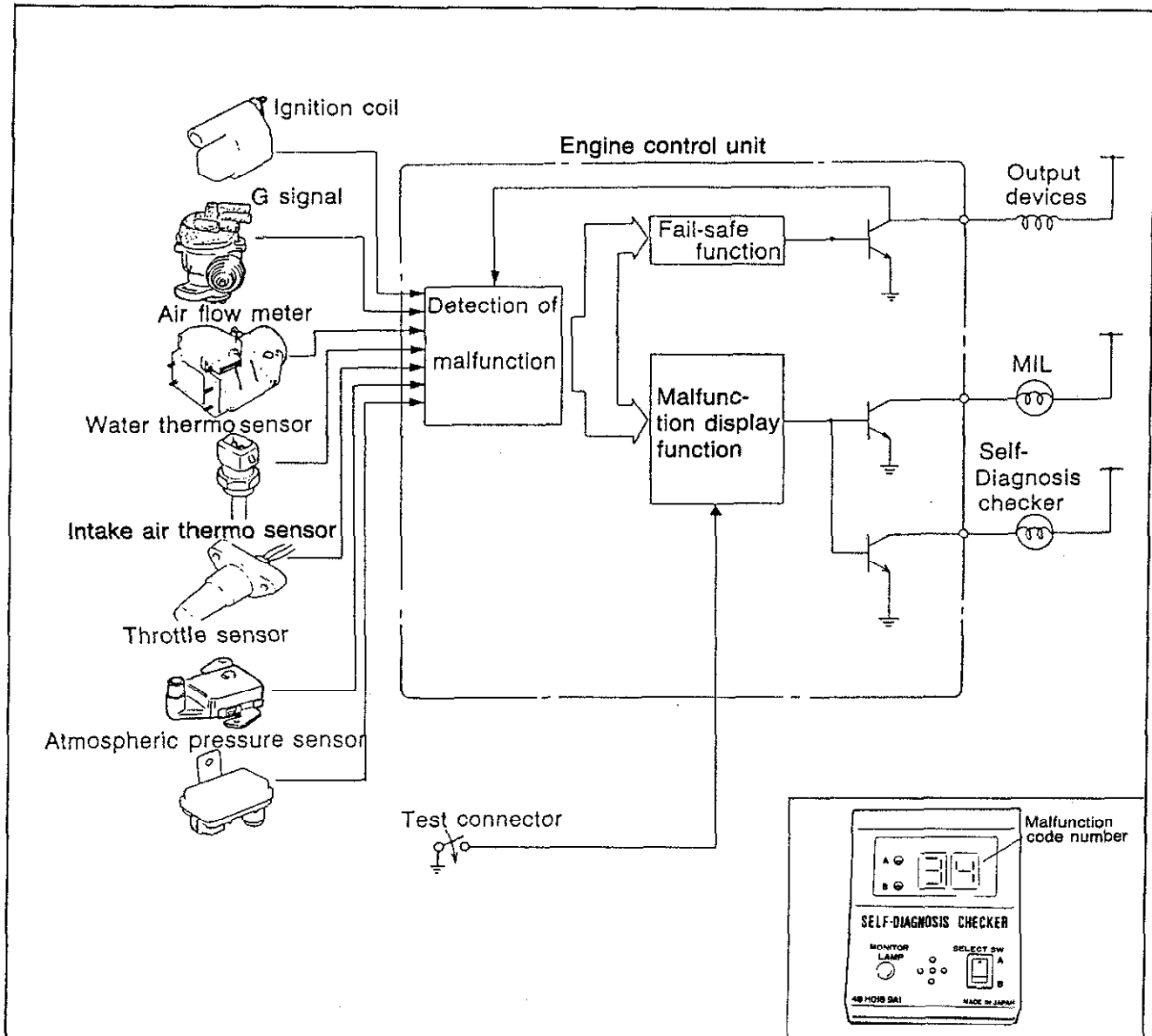

69G04A-020

When troubles occur in the main input devices or output devices, check for the cause using **SST**. Using the **SST**, failures of each input and output device are indicated and retrieved from the control unit as malfunction code numbers.

#### Note

The control unit constantly checks for malfunction of the input devices. But, the control unit checks for malfunction of output devices only in a 3 second period after the ignition switch is turned ON and the test connector is grounded.

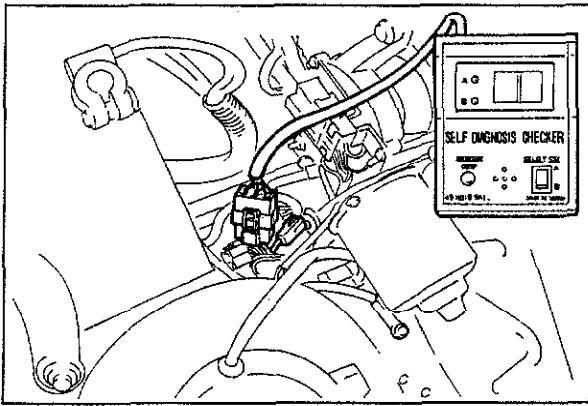

83U04B-011

## INSPECTION PROCEDURE

1. Warm-up the engine to normal operating temperature and stop it.
2. Connect **SST** to the check connector (Green: 6pin) and the battery negative cable.

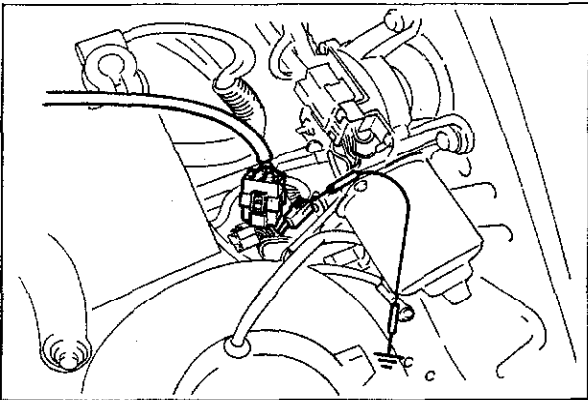

69G04C-123

3. Connect a jumper wire between the test connector (Green: 1pin) and a ground.
4. Turn the ignition switch ON, then check for any code number.

### Note

**The SST buzzer should sound for 3 sec. after the ignition switch is turned ON.**

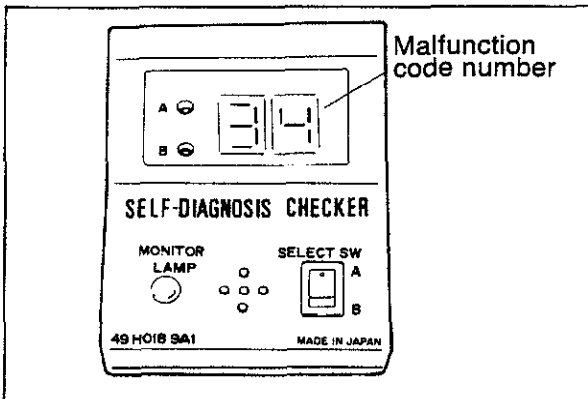

69G04A-023

5. Start the engine, and check for further code numbers.
6. If a code number illuminates, check for the cause of the problem.

# 4B TROUBLESHOOTING WITH SST

If a warning code number is illuminated on **SST**, check the following chart along with the wiring diagram.

## No. 01 code illumination (Ignition Pulse)

PC: Possible Cause

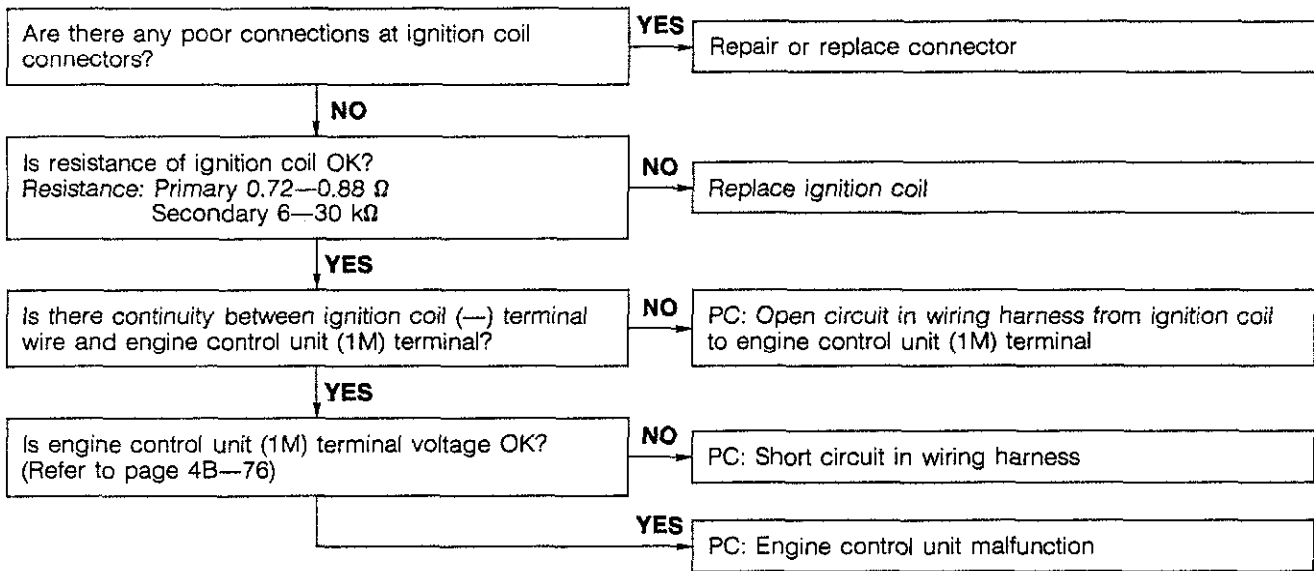

83U04B-012

## No. 03 Code Illumination (G Signal)

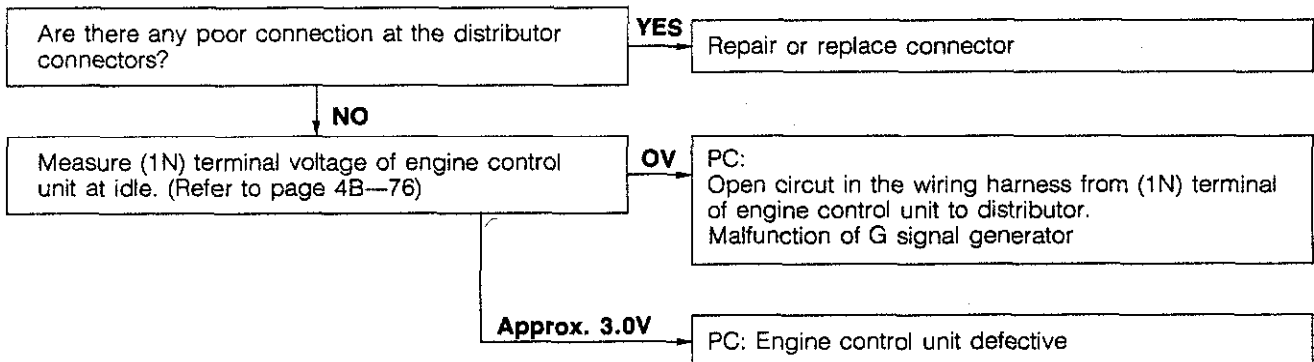

83U04B-013

**No. 08 Code illumination (Air Flow Meter)**

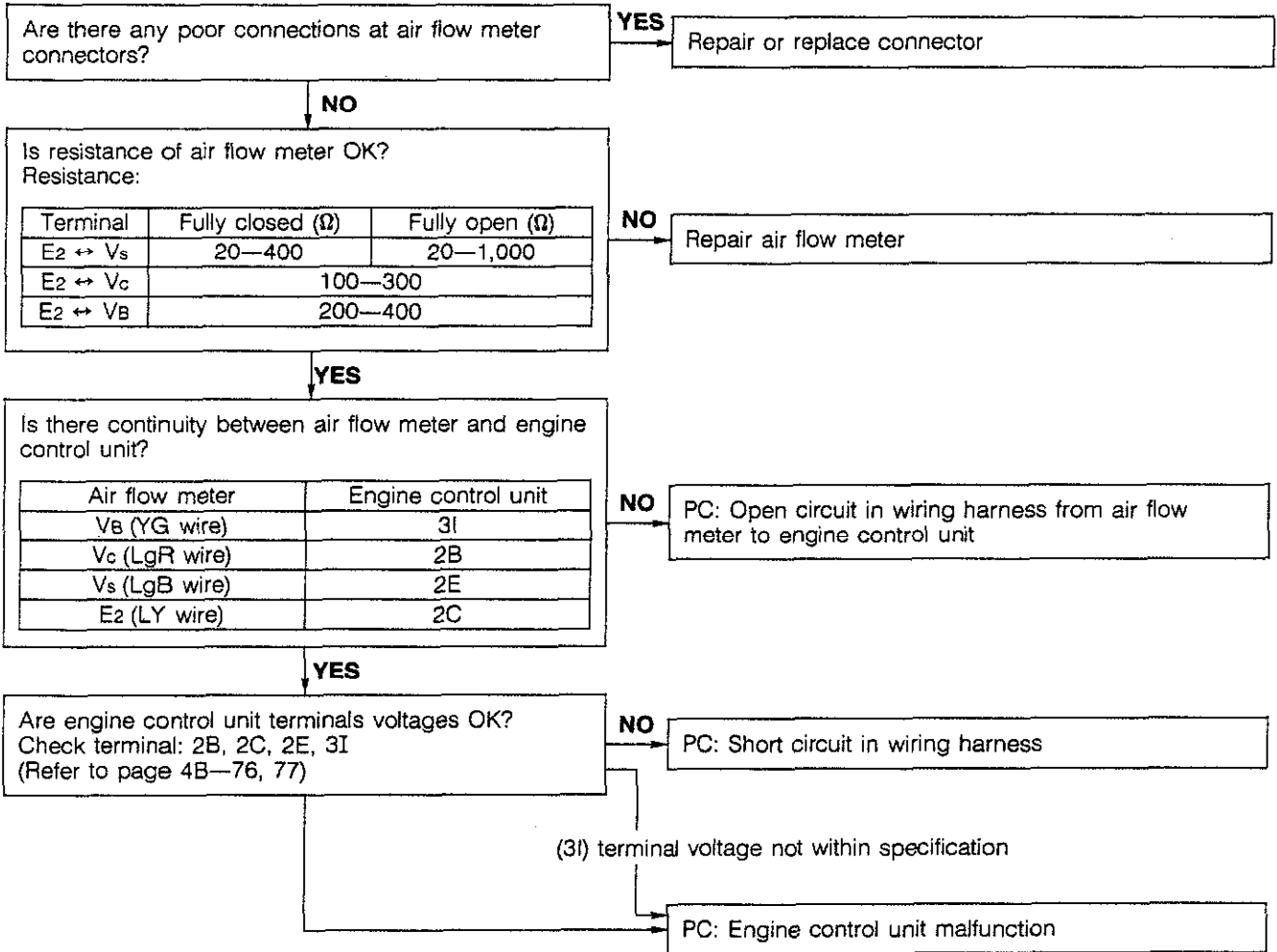

83U04B-014

# 4B TROUBLESHOOTING WITH SST

## No. 09 Code illumination (Water Thermo Sensor)

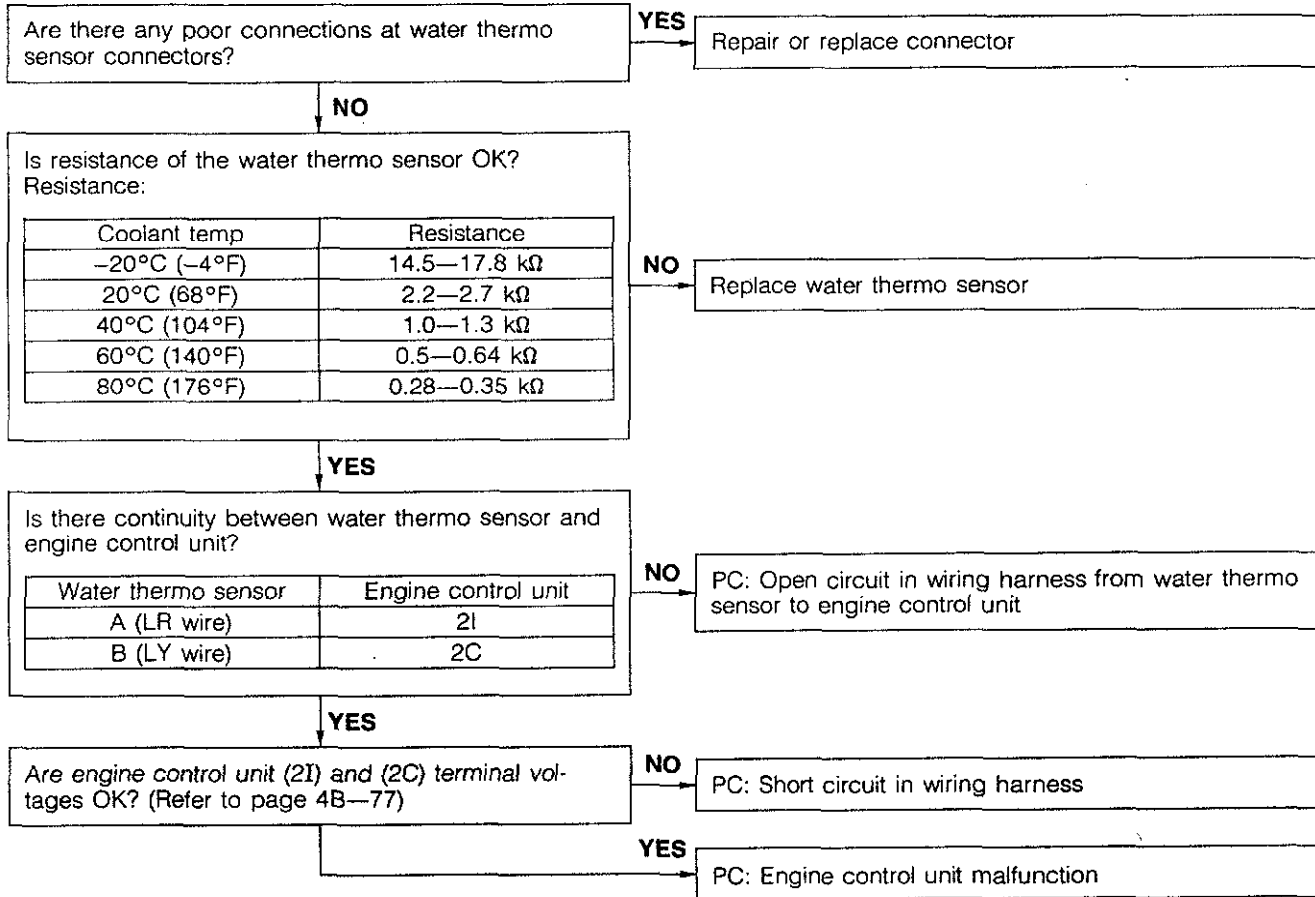

83U04B-015

## No. 10 Code illumination (Intake Air Thermo Sensor)

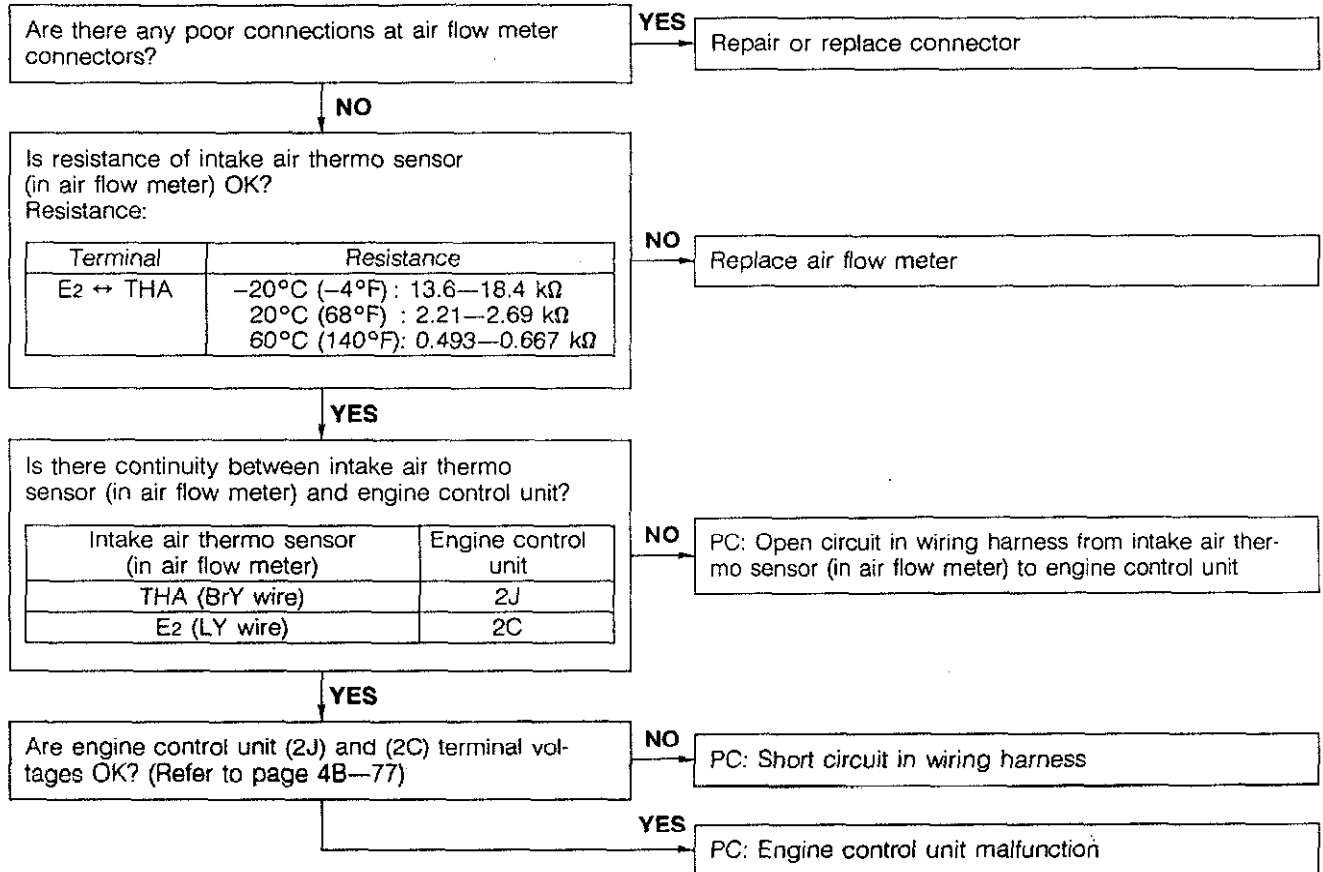

83U04B-016

## No. 12 Code Illumination (Throttle Sensor)

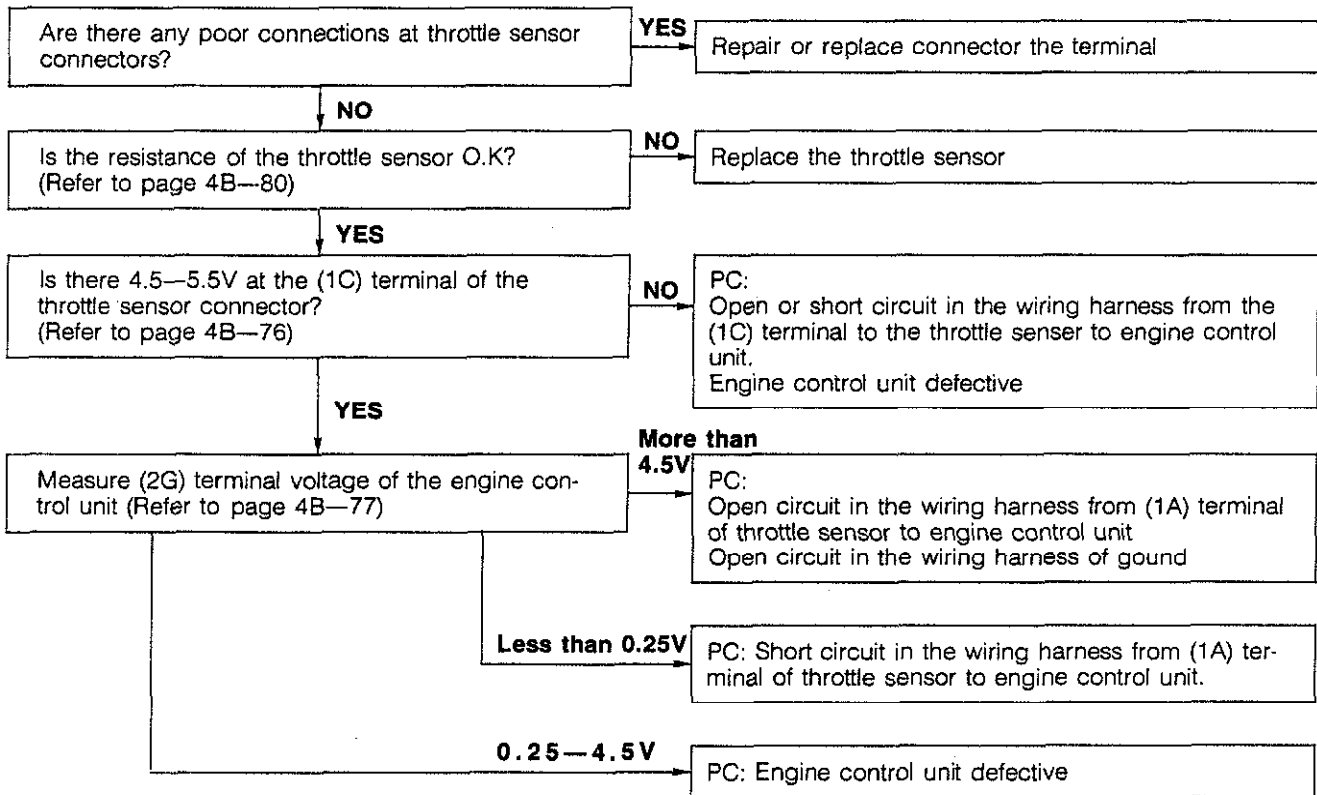

83U04B-017



## No. 14 Code illumination (Atmospheric Pressure Sensor)

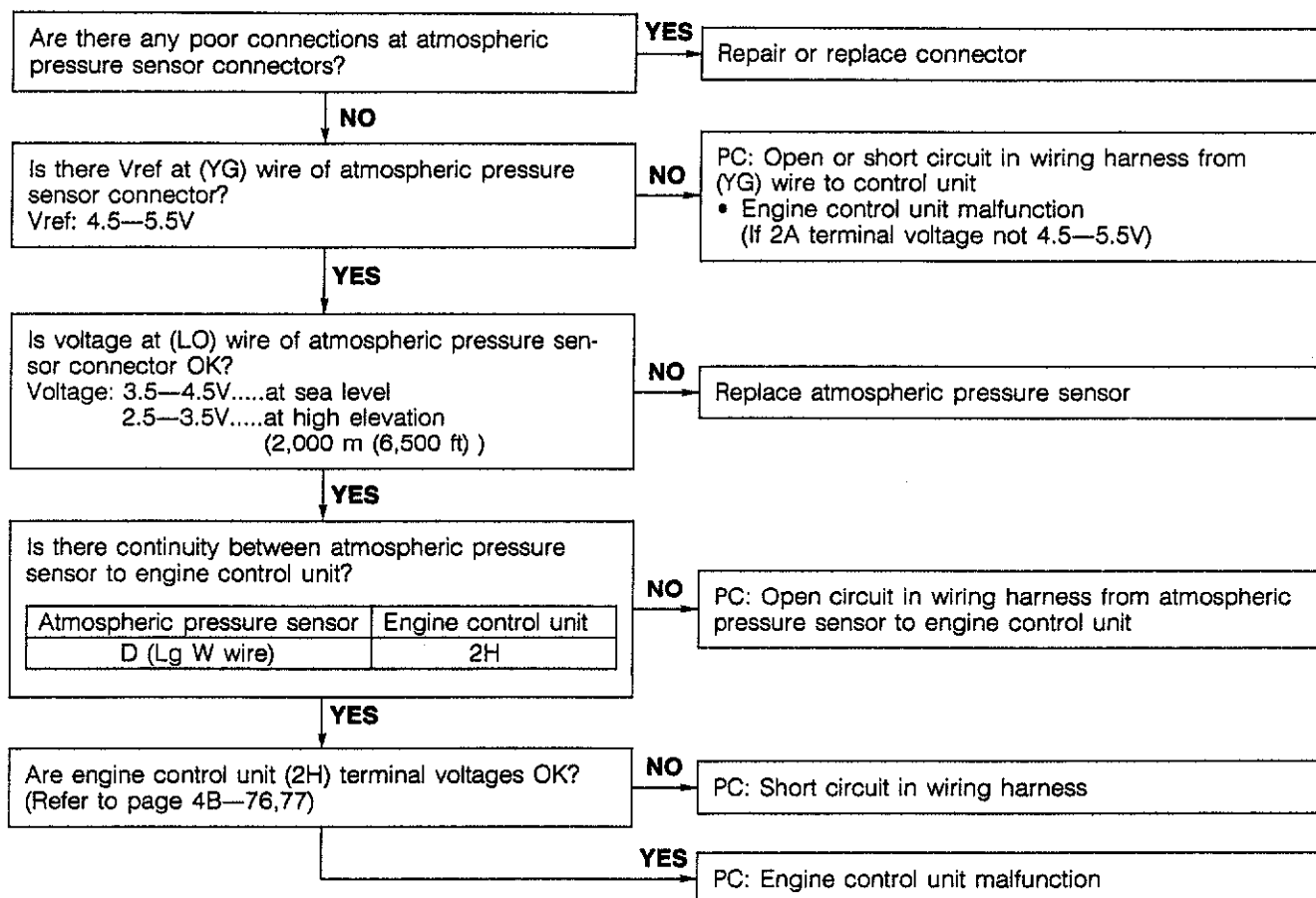

83U04B-018

## No. 15 Code display illumination (Oxygen Sensor)

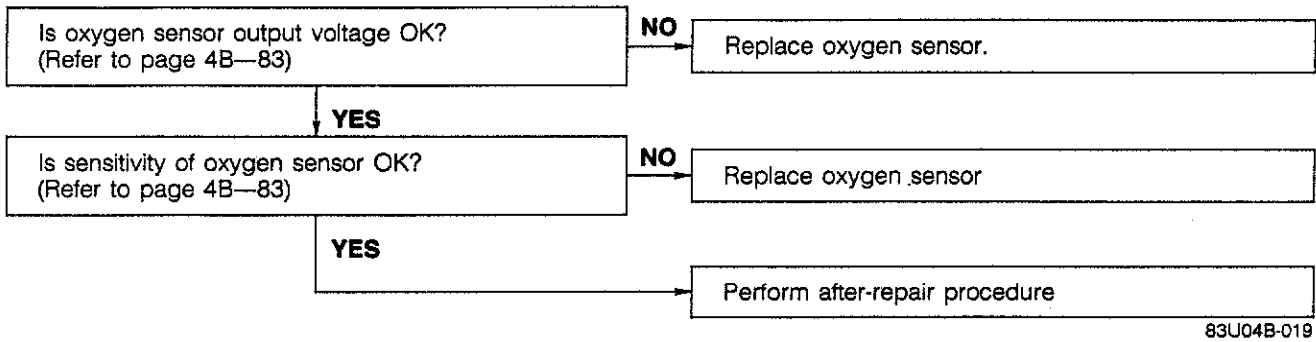

## No. 17 Code display illumination (Feedback System)

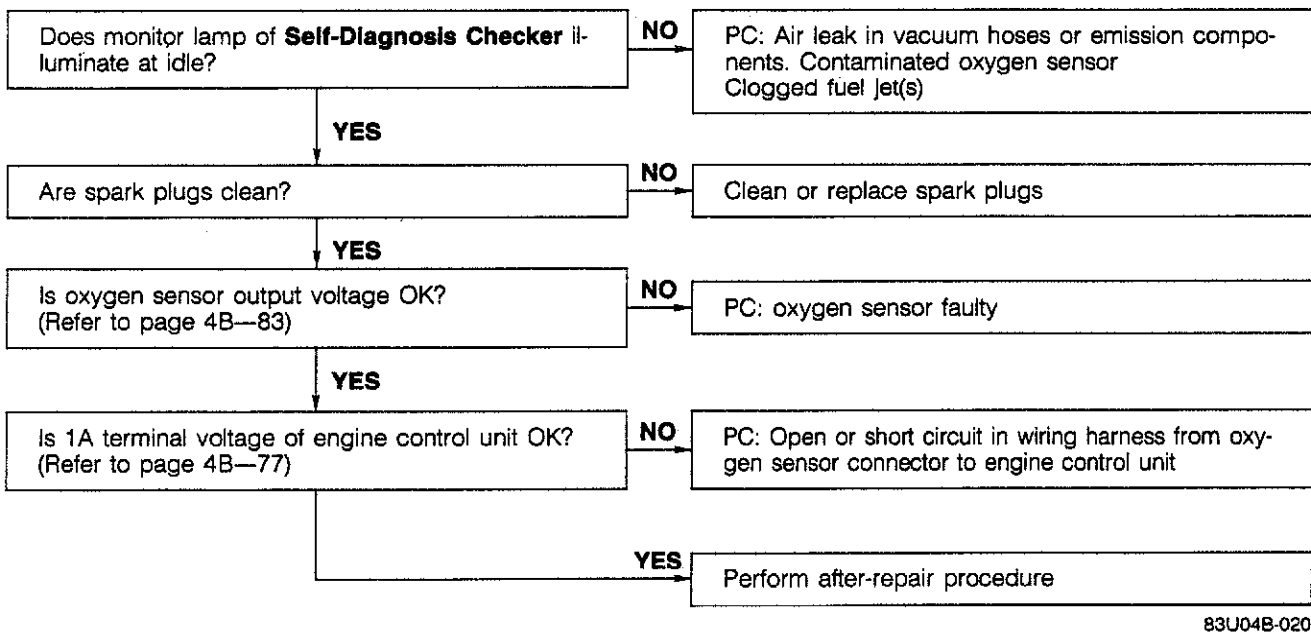

**No. 25, 26, 27 Code Illumination (Solenoid Valve)**

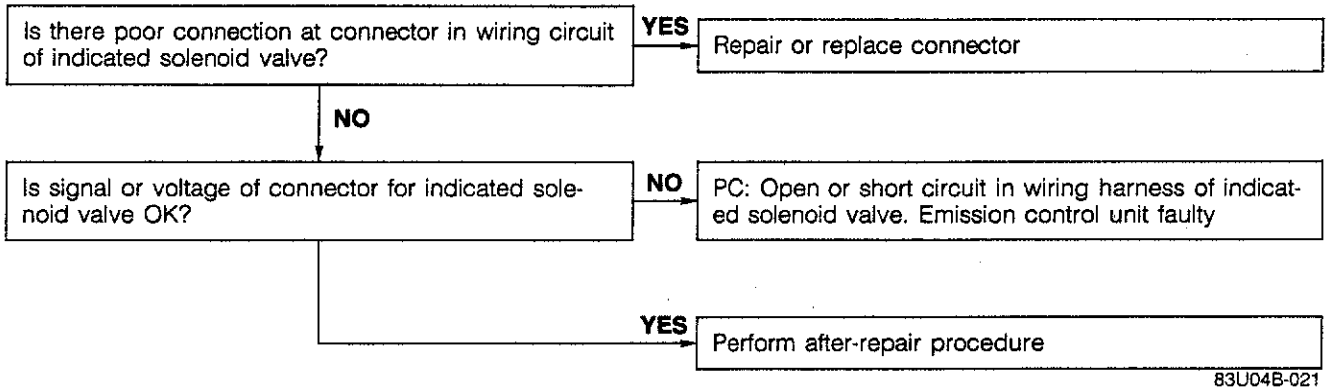

**No. 34 Code illumination (BAC Valve)**

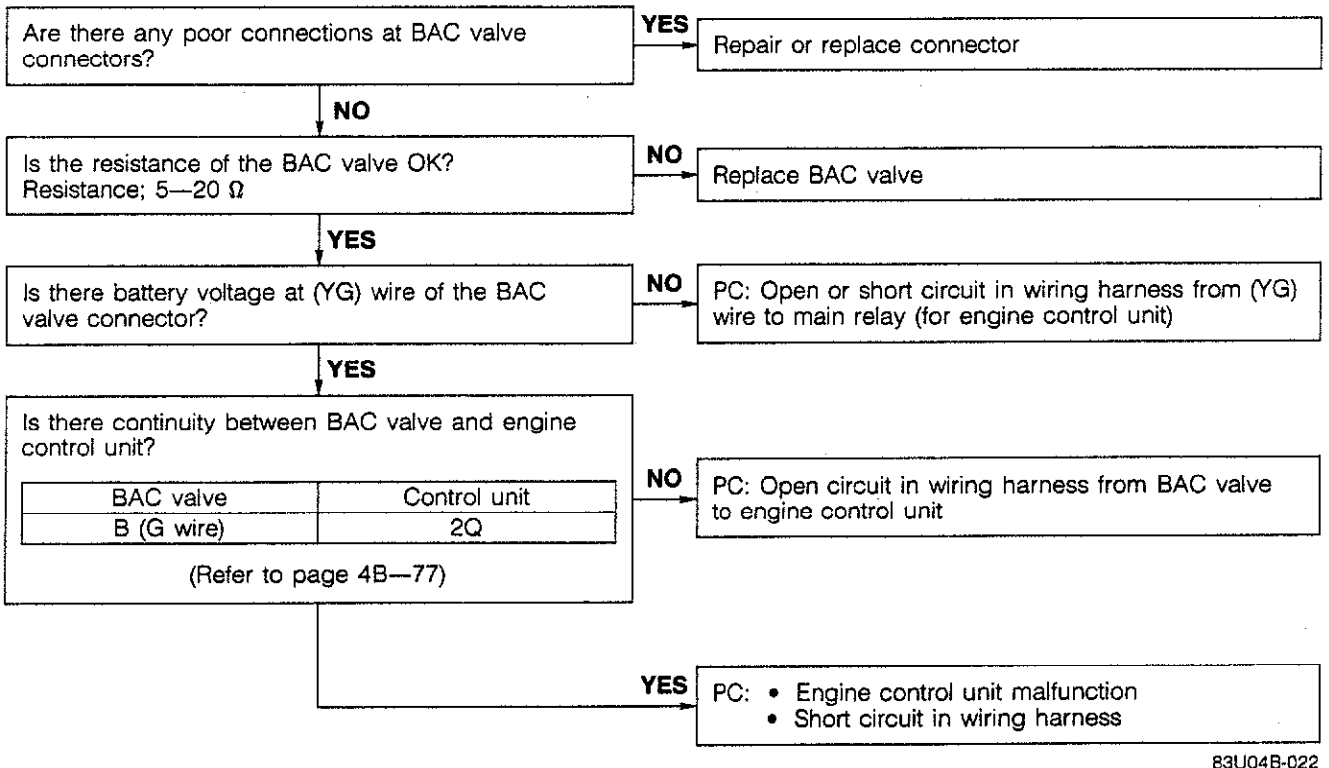

BAC valve	Control unit
B (G wire)	2Q

(Refer to page 4B—77)

## MONITOR SWITCH FUNCTION

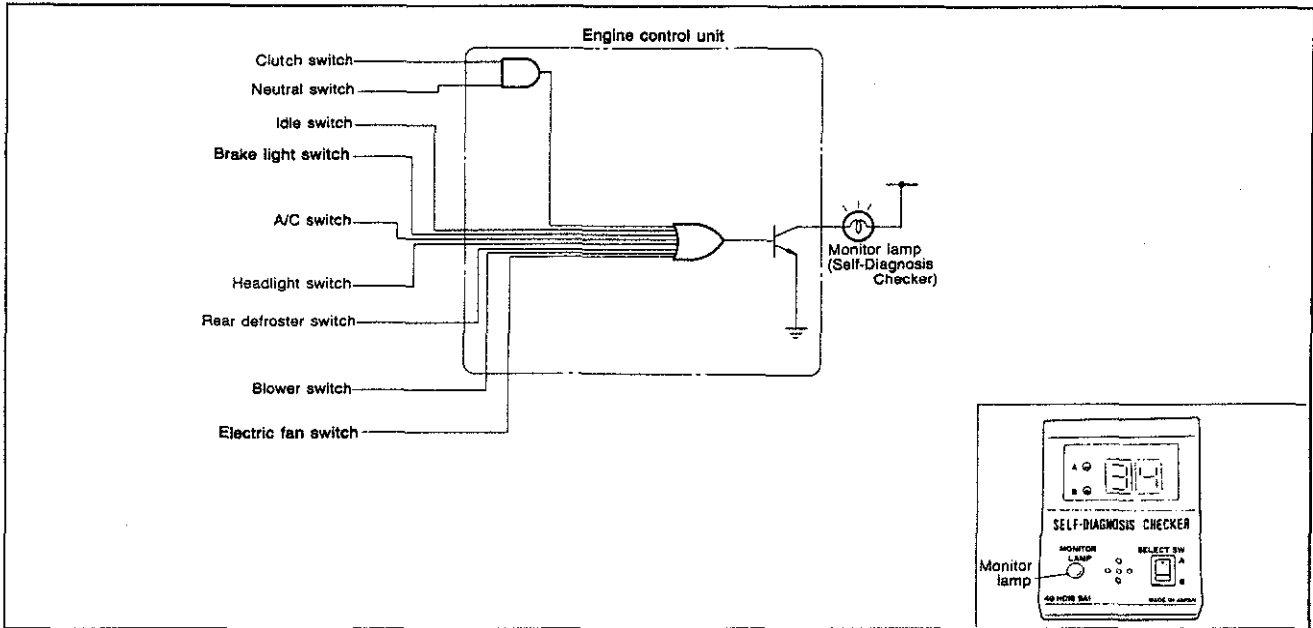

83U04B-023

The operation of individual switches can be determined by the monitor lamp SST.

**Note**

The test connector must be grounded and the ignition switch ON (engine stopped) to check the switches.

Switch	Self-Diagnosis Checker		Remarks
	Monitor lamp ON	Monitor lamp OFF	
Clutch switch	Pedal released	Pedal depressed	Gear: IN
Neutral switch	In gear	Neutral	Clutch pedal released
Idle switch (Throttle sensor)	Pedal depressed	Pedal released	
Brake light switch	Pedal depressed	Pedal released	
A/C switch	ON	OFF	Blower motor position: "1" position
Headlight switch	ON	OFF	
Rear defroster switch	ON	OFF	
Blower switch	ON	OFF	Blower motor position: "3" position
Water thermo switch (Electric fan)	Disconnected terminal	Connected terminal	

## OXYGEN SENSOR MONITOR FUNCTION

The oxygen sensor and feedback mode are monitored as follows.

Condition		Item monitored	Function
Engine	Test connector		
Running	Not grounded	Oxygen sensor output signal	Oxygen sensor output more than 0.55V: Monitor lamp ON
		Oxygen sensor output signal	Oxygen sensor output less than 0.55V: Monitor lamp OFF

86U04X-582

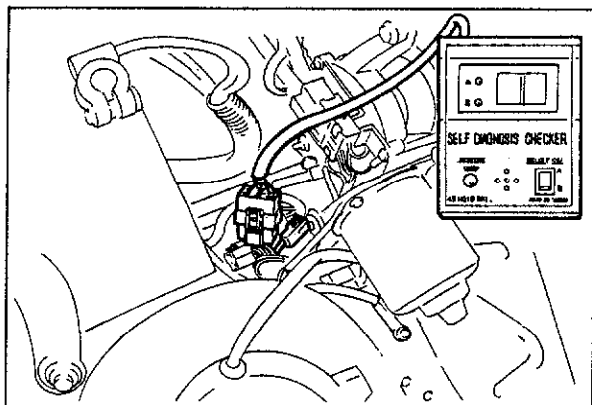

83U04B-024

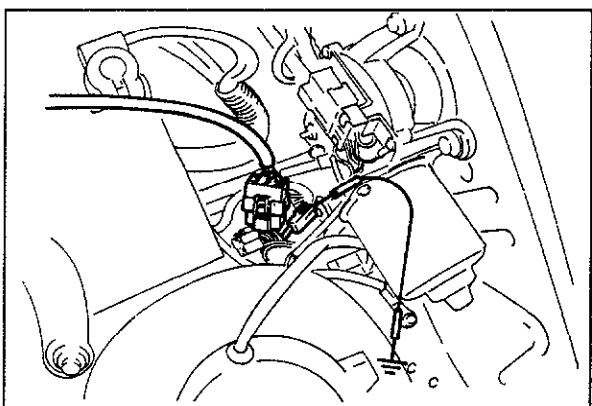

83U04B-025

## INSPECTION PROCEDURE

1. Warm up the engine to normal operating temperature and stop it.
2. Connect **SST** to the check connector (Green: 6 pin) and the battery negative terminal.

3. Connect a jumper wire between the test connector (Green: 1 pin) and a ground.
4. Turn the ignition switch ON, then check that the monitor lamp illuminates when each switch is made to function according to below procedure.

### Caution

- a) When even one of the switches is activated, the monitor lamp will stay on.
- b) Do not start the engine.

## Procedure

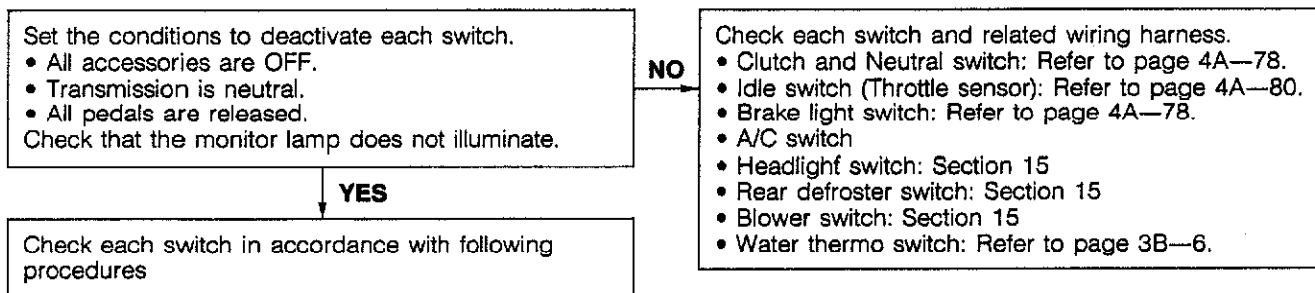

## Neutral and clutch switch (for MTX)

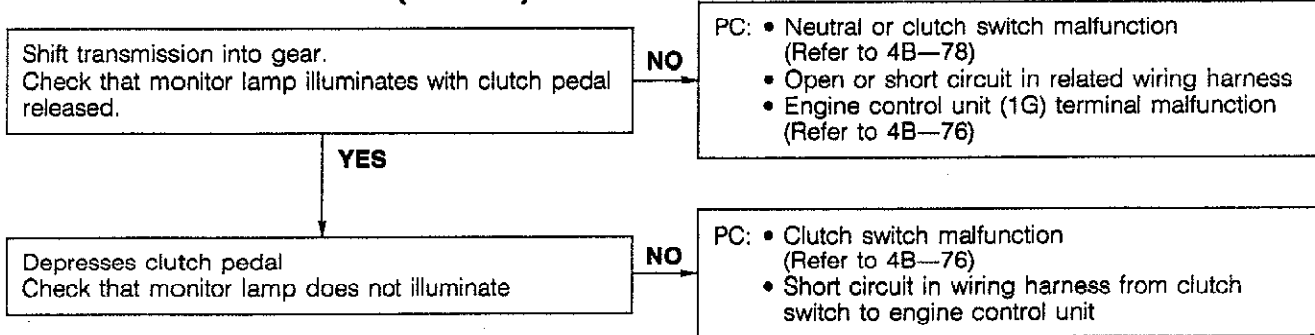

83U04B-026

# 4B MONITOR SWITCH FUNCTION

## Idle switch (Throttle sensor)

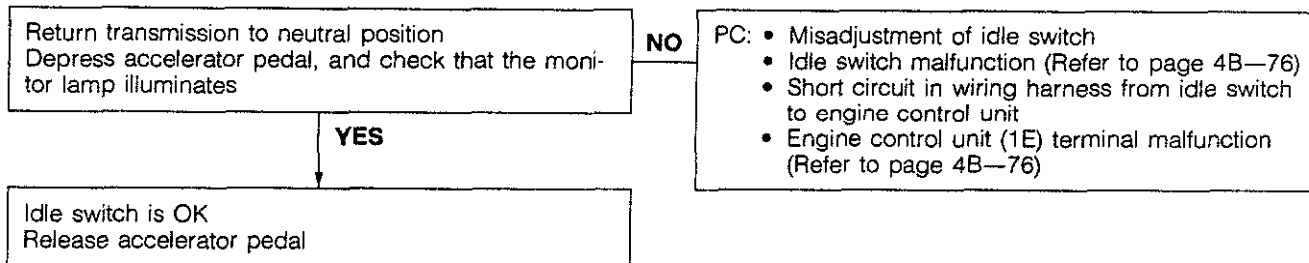

83U04B-027

## Brake light switch

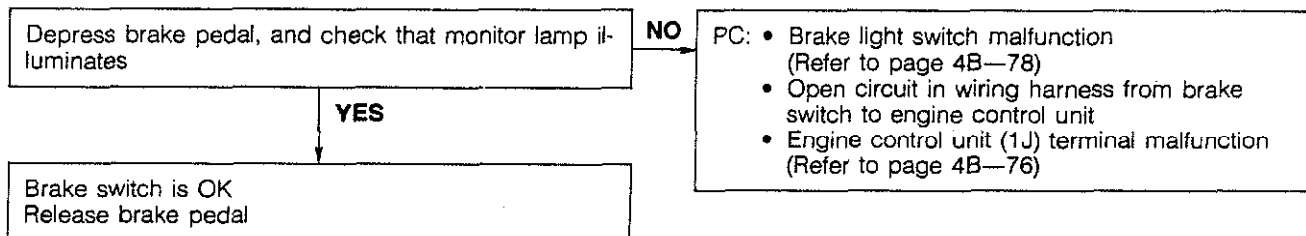

83U04B-028

## Blower switch

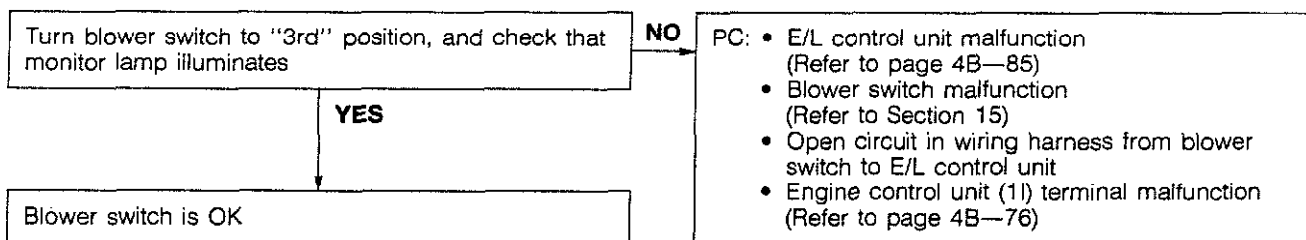

83U04B-029

## A/C switch

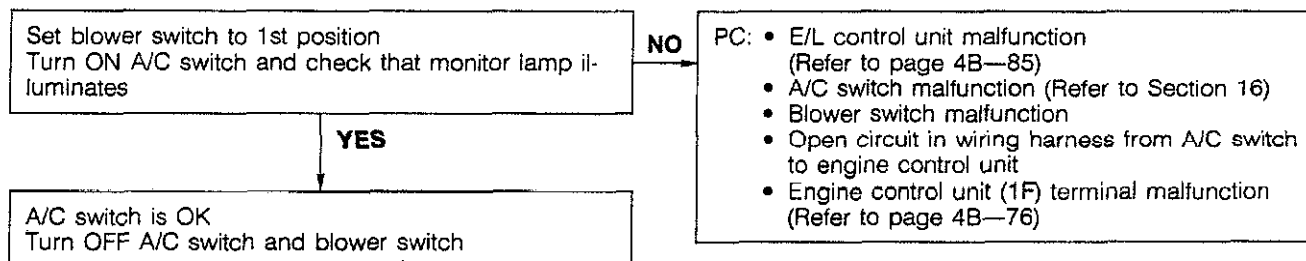

83U04B-030

## Headlight switch

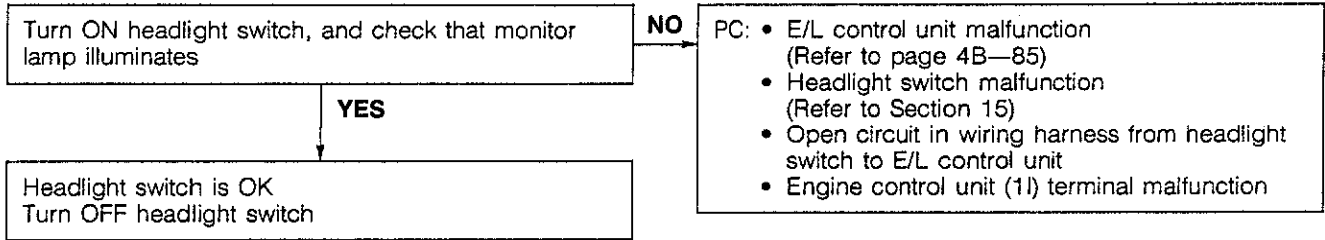

83U04B-031

## Rear defroster switch

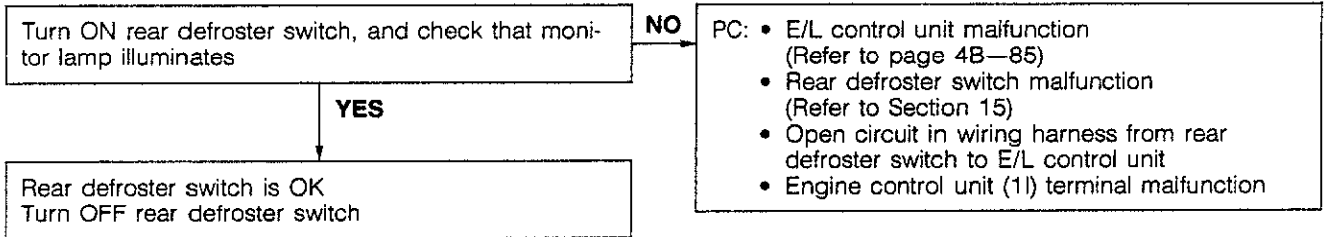

83U04B-032

## Water thermo switch circuit (not include switch inspection)

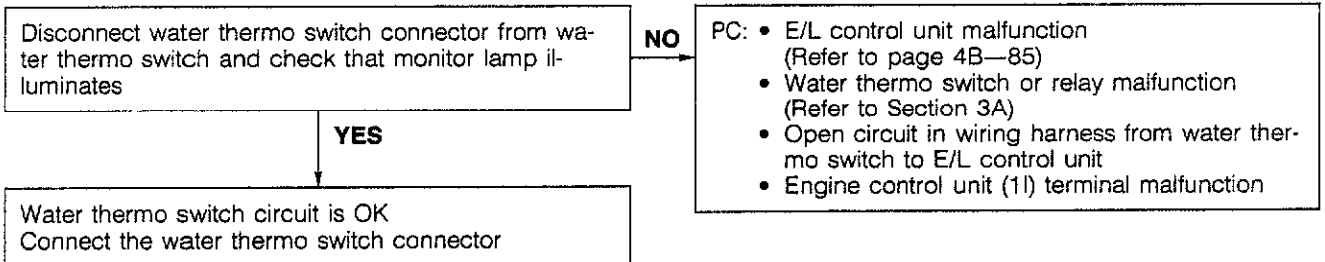

83U04B-033

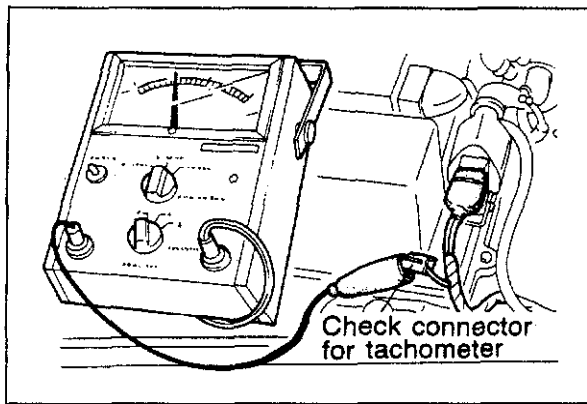

83U04B-034

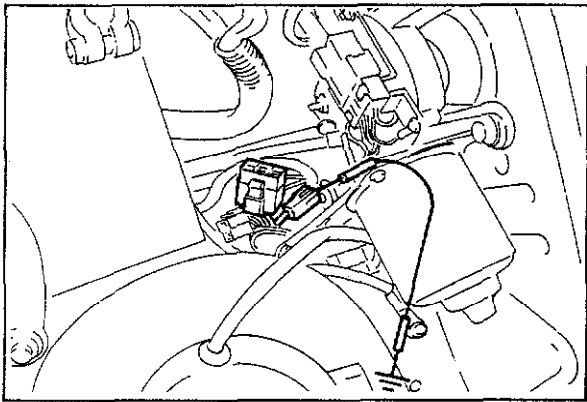

83U04B-035

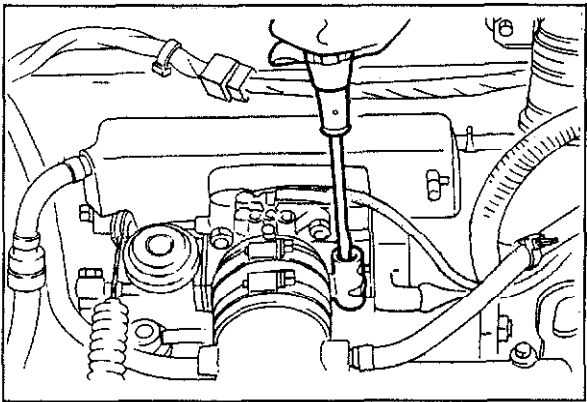

83U04B-036

## IDLE ADJUSTMENT

### Preparation

Before checking or adjusting the idle speed, perform the followings:

- Switch off all accessories.
- Connect a tachometer to check connector (White).
- Warm up the engine to normal operating temperature.
- Check and adjust the ignition timing.

- Connect a jump wire between the test connector and ground.

### Idle speed

1. Check the idle speed.

**Idle speed:  $850 \pm 50$  rpm**

2. If the idle speed is not within specification, remove the blind cap from air adjust screw and adjust it by turning the air adjust screw.
3. After adjusting the idle speed, install the blind cap and disconnect a jumper wire from the test connector.

### Note

**Check and adjust the dashpot operation after adjusting the idle speed.**



**INTAKE AIR SYSTEM**

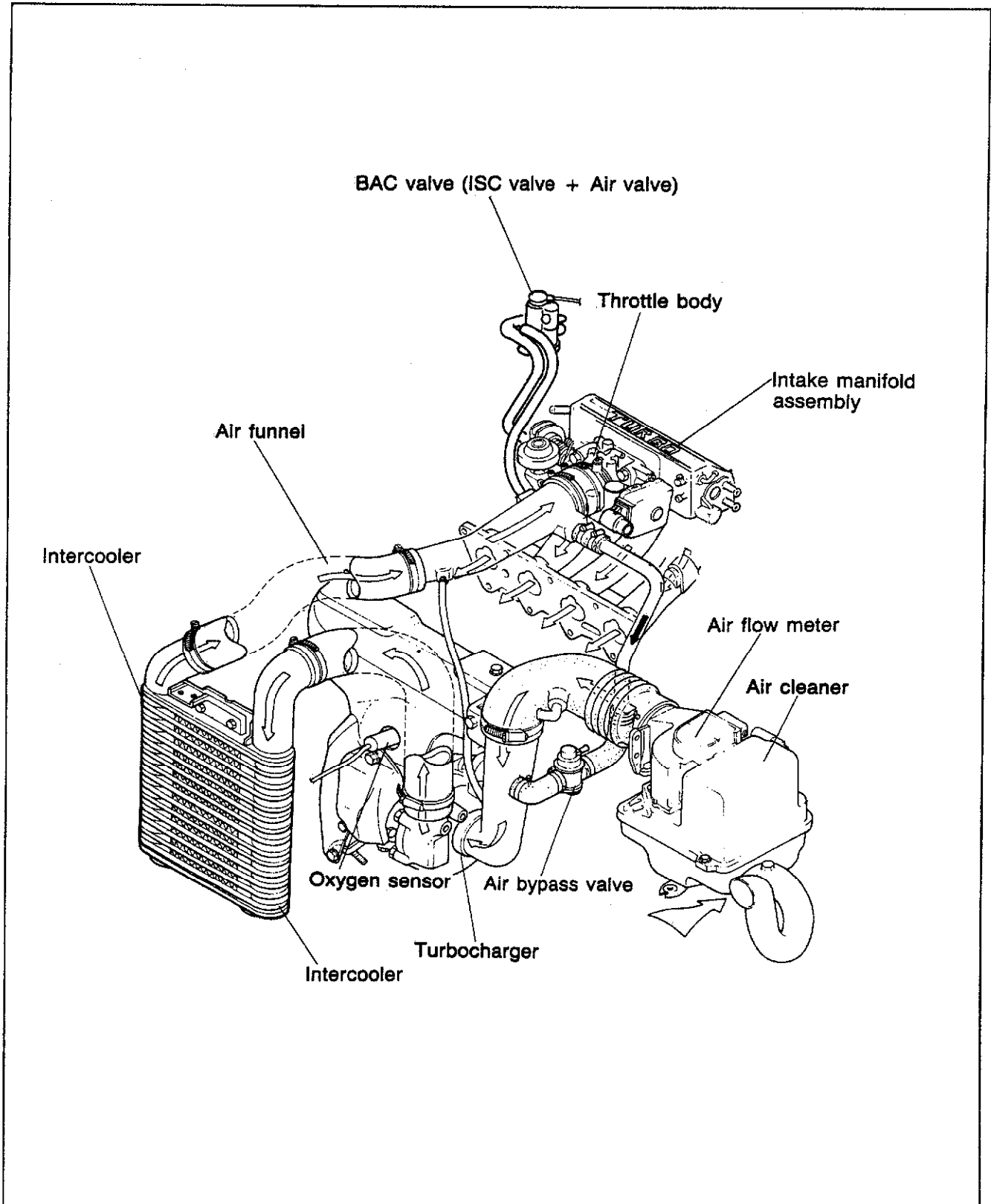

83U04B-160

This system is comprised of the air cleaner, air flow meter, turbocharger, intercooler, air bypass valve, air funnel, throttle body, intake manifold assembly, and BAC valve.

# 4B INTAKE AIR SYSTEM

## REMOVAL AND INSPECTION

1. Disconnect the negative battery cable.
2. Remove the intake air system in accordance with the following order.
3. Install in the reverse order of removal.

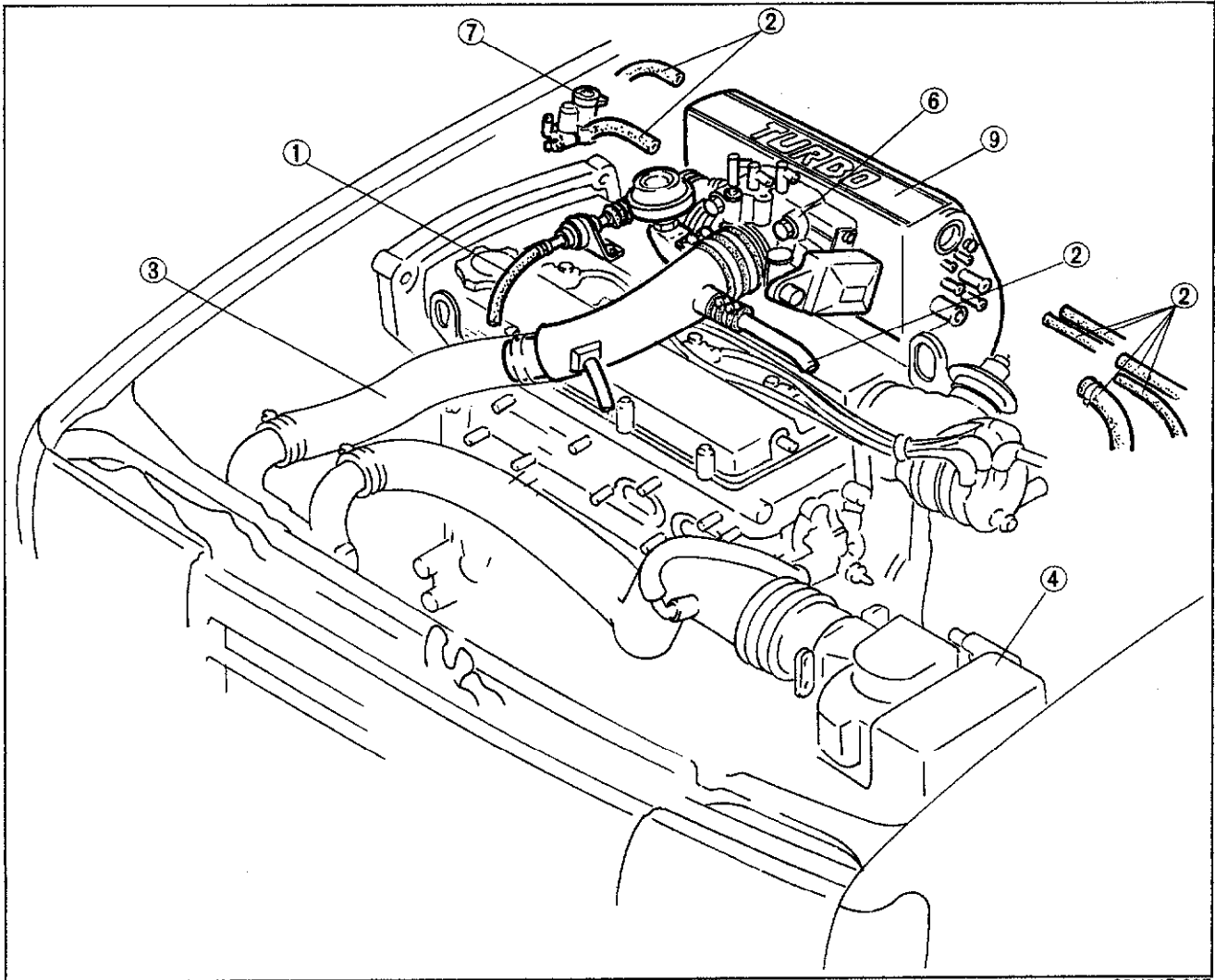

83U04B-037

- |                               |                                |
|-------------------------------|--------------------------------|
| 1. Accelerator cable          | 6. Throttle body               |
| 2. Air hoses and vacuum hoses | 7. BAC valve                   |
| 3. Air funnel                 | 8. Water hose (for oil cooler) |
| 4. Air cleaner                | 9. Intake manifold assembly    |
| 5. Water hoses                |                                |

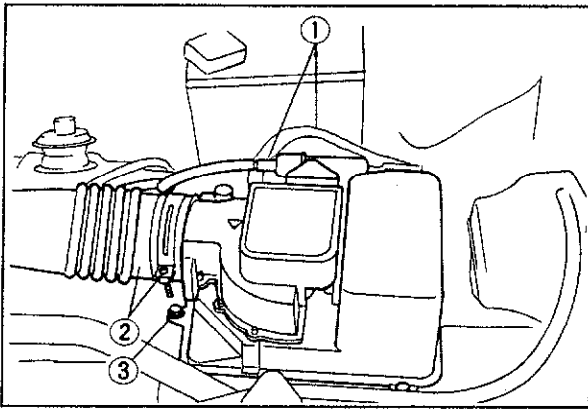

83U04B-038

## Air Flow Meter Removal and Installation

1. Remove the high tension leads and connectors.
2. Loosen the hose band and remove the intake air hose.
3. Remove the attaching bolts of air cleaner cover.

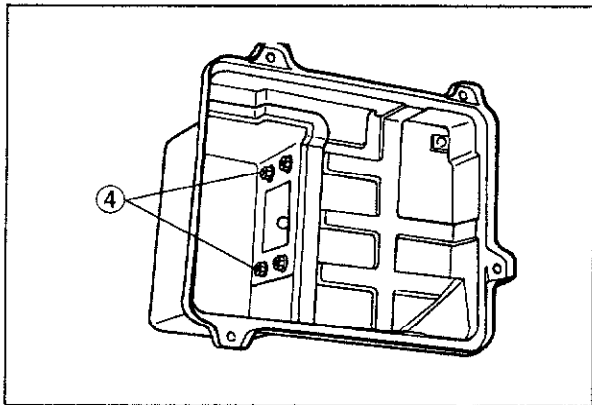

83U04B-039

4. Turn the air cleaner cover upside down and remove the attaching nuts of air flow meter.
5. Remove the air flow meter.

Install in the reverse order of removal.

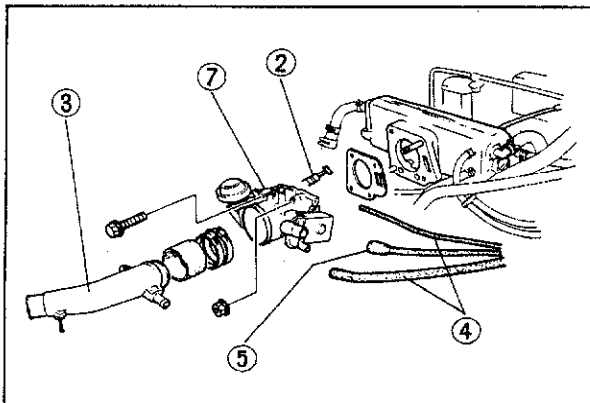

83U04B-040

## Throttle Body Removal and Installation

1. Drain the water from radiator
2. Disconnect the accelerator cable from the throttle linkage
3. Disconnect the air funnel
4. Disconnect the hoses and tubes
5. Disconnect the throttle sensor connector
6. Remove the attaching nuts and bolts of throttle body
7. Remove the throttle body
8. Install in the reverse order of removal

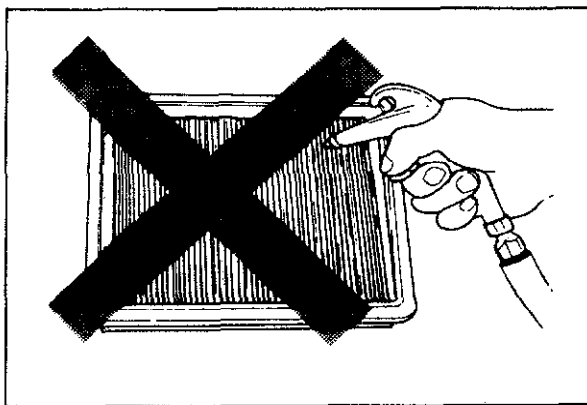

69G04A-059

## PARTS INSPECTION Air Cleaner Element

### Caution

**Do not use the compressed air to clean the air cleaner element.**

1. Check the condition of the air cleaner element.
2. Replace, if necessary.

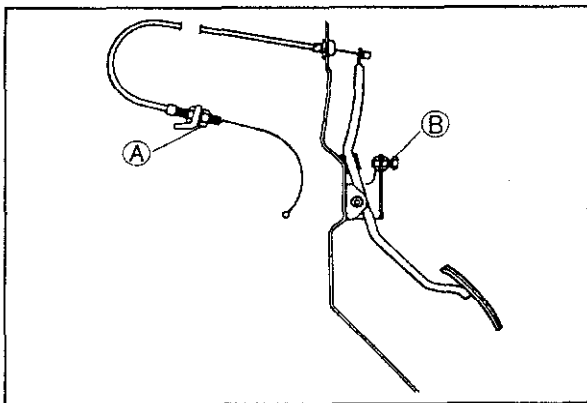

69G04A-060

## Accelerator Cable

1. Inspect the deflection of the cable. If the deflection is not within **1 ~ 3 mm (0.04 ~ 0.12 in.)**, adjust by using nuts (A).
2. Depress the accelerator pedal to the floor and confirm that the throttle valve is fully opened. Adjust by using bolt (B) if necessary.

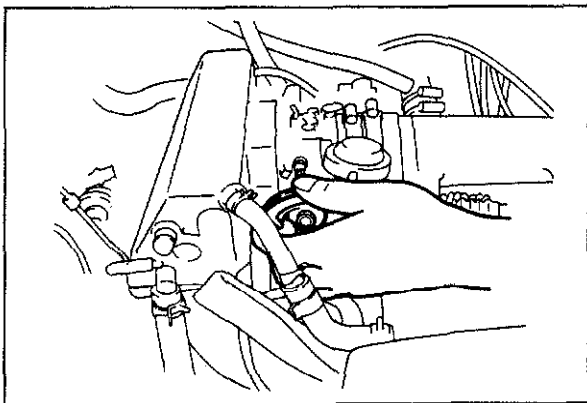

83U04B-042

## Throttle Body

1. Check that the throttle valve move smoothly when the throttle lever is moved from fully closed and fully open.
2. Replace, if necessary.

### Note

**For inspection and adjustment of the throttle sensor, refer to Control System (Page 4B—80).**

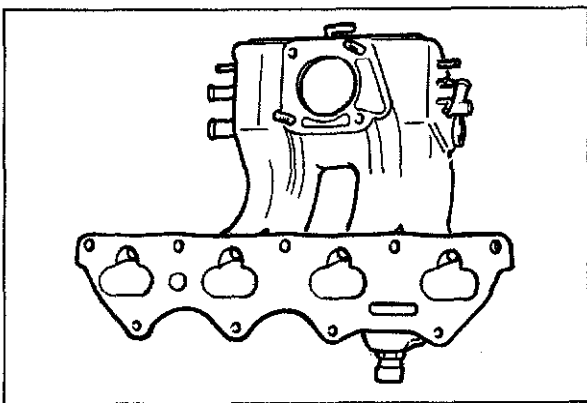

83U04B-043

## Intake manifold assembly

1. Visually check the intake manifold assembly for damage.
2. Replace, if necessary.

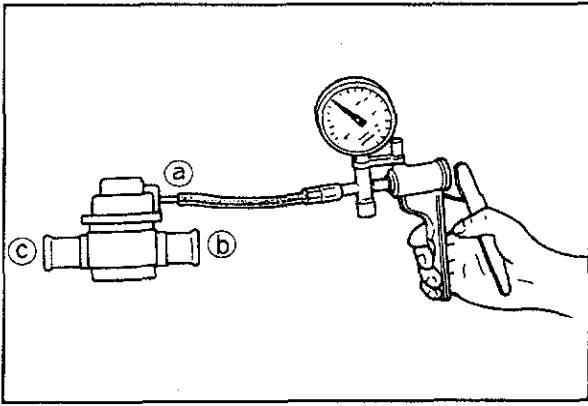

83U04B-044

## AIR BYPASS VALVE

### Inspection

1. Remove the air bypass valve.
2. Connect a vacuum pump tester to port (a) of the valve.
3. Apply vacuum and check that the air flow through the valve from port (b) to port (c) at **100—370 mmHg (3.94—14.58 inHg)** of the vacuum.
4. Replace the valve if necessary.

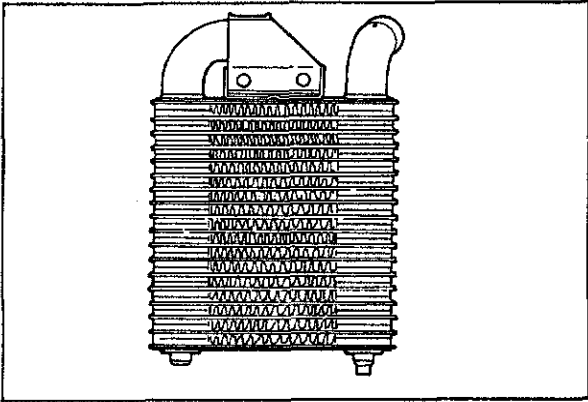

63G04C-327

## INTERCOOLER

### Inspection

1. Remove the intercooler.
2. Inspect the intercooler for cracks, restriction, or damage, replace if necessary.

## IDLE SPEED CONTROL (ISC) SYSTEM

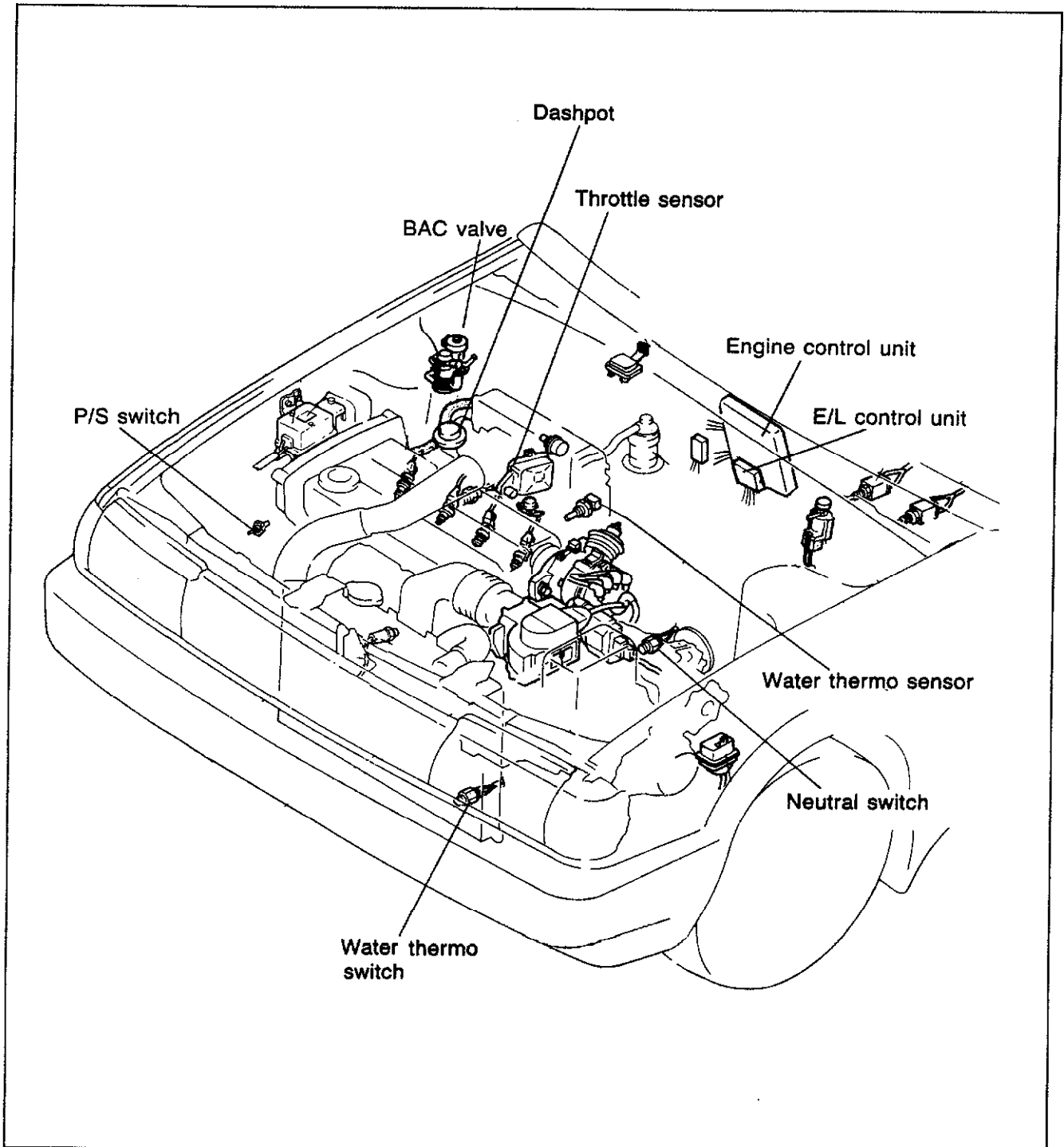

### OUTLINE

To improve idle smoothness, the ISC system controls the intake air amount detected by the air flow meter by regulating the bypass air amount that passes through the throttle body, and thereby helps the engine to maintain a steady idle speed.

This system consists of the BAC valve and the control system.

The BAC valve consists of the air valve which functions only during cold engine conditions and the ISC valve which works throughout the entire engine speed range.

## TROUBLESHOOTING CHART

Before performing the following troubleshooting, check the condition of the wiring harness and connector.

SYMPTOM		POSSIBLE CAUSE					
		Water thermo sensor	Intake air thermo sensor	Throttle sensor (Variable resistor type)	ISC system (System inspection)	BAC valve	Engine control unit terminal voltage
		4B-82	4B-79	4B-80	4B-34	4B-35	2Q 4B-77
Engine stall	While warming up	3	4		1	2	5
	After warming up	3	4		1	2	5
Rough Idle	While warming up	3	4		1	2	5
	After warming up	3	4		1	2	5
High Idle speed after warming up		3	4		1	2	5
Runs rough on deceleration		4	5	3	1	2	6
Afterburn in exhaust system		4	5	3	1	2	6
Fail emission test		4	5	3	1	2	6

83U04B-046

# 4B IDLE SPEED CONTROL (ISC) SYSTEM

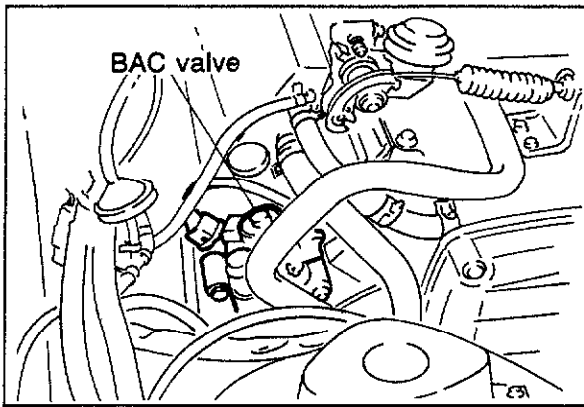

83U04B-047

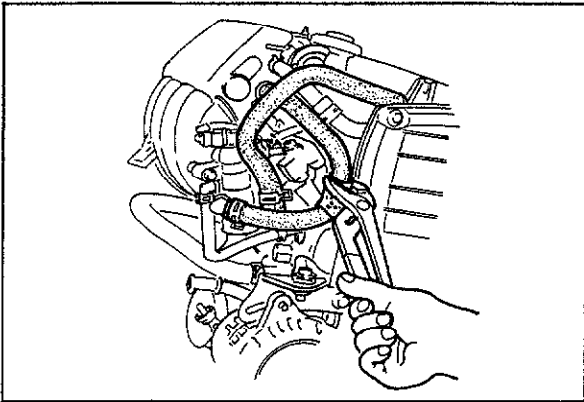

83U04B-048

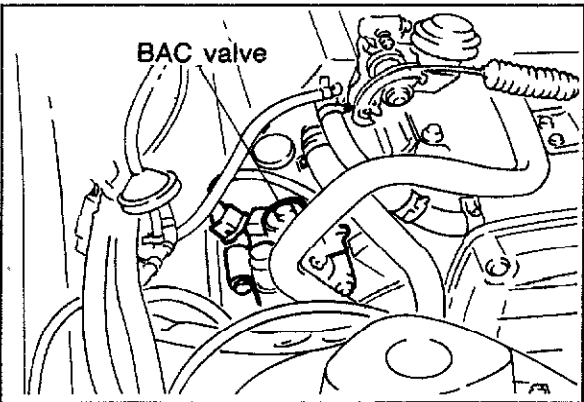

83U04B-049

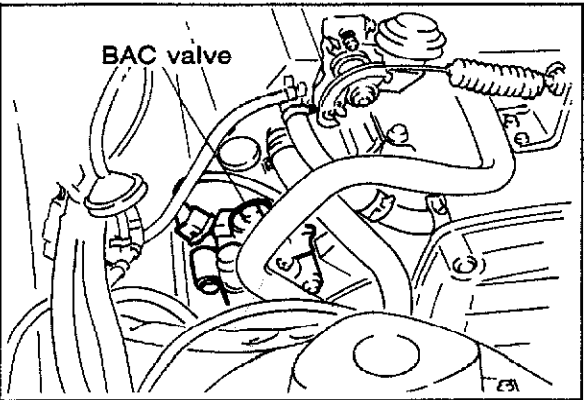

83U04B-050

## System Inspection

1. Connect the jumper wire between the test connector (Green: 1 pin) and ground.
2. Disconnect the BAC valve connector.
3. Start the engine and run it at idle.

### Note

**When the BAC valve is disconnected, the engine speed will be reduced, which is normal.**

4. Pinch the air hose and note the engine speed.

**Cold engine: Engine speed drops**

**Warm engine: Engine speed unchanged**

5. Connect the BAC valve connector.
6. Disconnect the jumper wire.
7. Warm up the engine to normal operating temperature and run it at idle.
8. Check that the idle speed is correct.

9. Connect the jumper wire between the test connector and ground.
10. Disconnect the BAC valve connector.
11. Check that the engine speed decreases.
12. Reconnect the BAC valve connector.



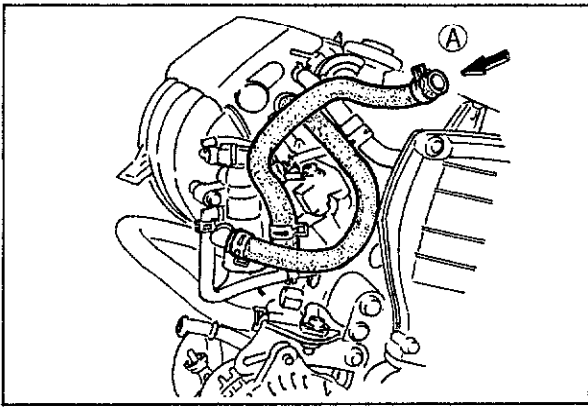

83U04B-051

## BAC Valve

### Air valve

1. Disconnect the air hoses from the air funnel.
2. Blow through the BAC valve from port (A). Check the air flow.

**Cold engine: Air flows**

**Warm engine: Air does not flow**

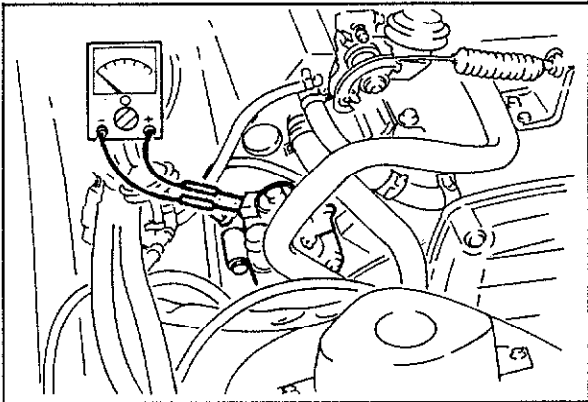

83U04B-052

## ISC valve

1. Disconnect the BAC valve connector.
2. Connect an ohmmeter to the terminals of the BAC valve.
3. Check the resistance.

**Resistance: 5—20  $\Omega$**

## FUEL SYSTEM

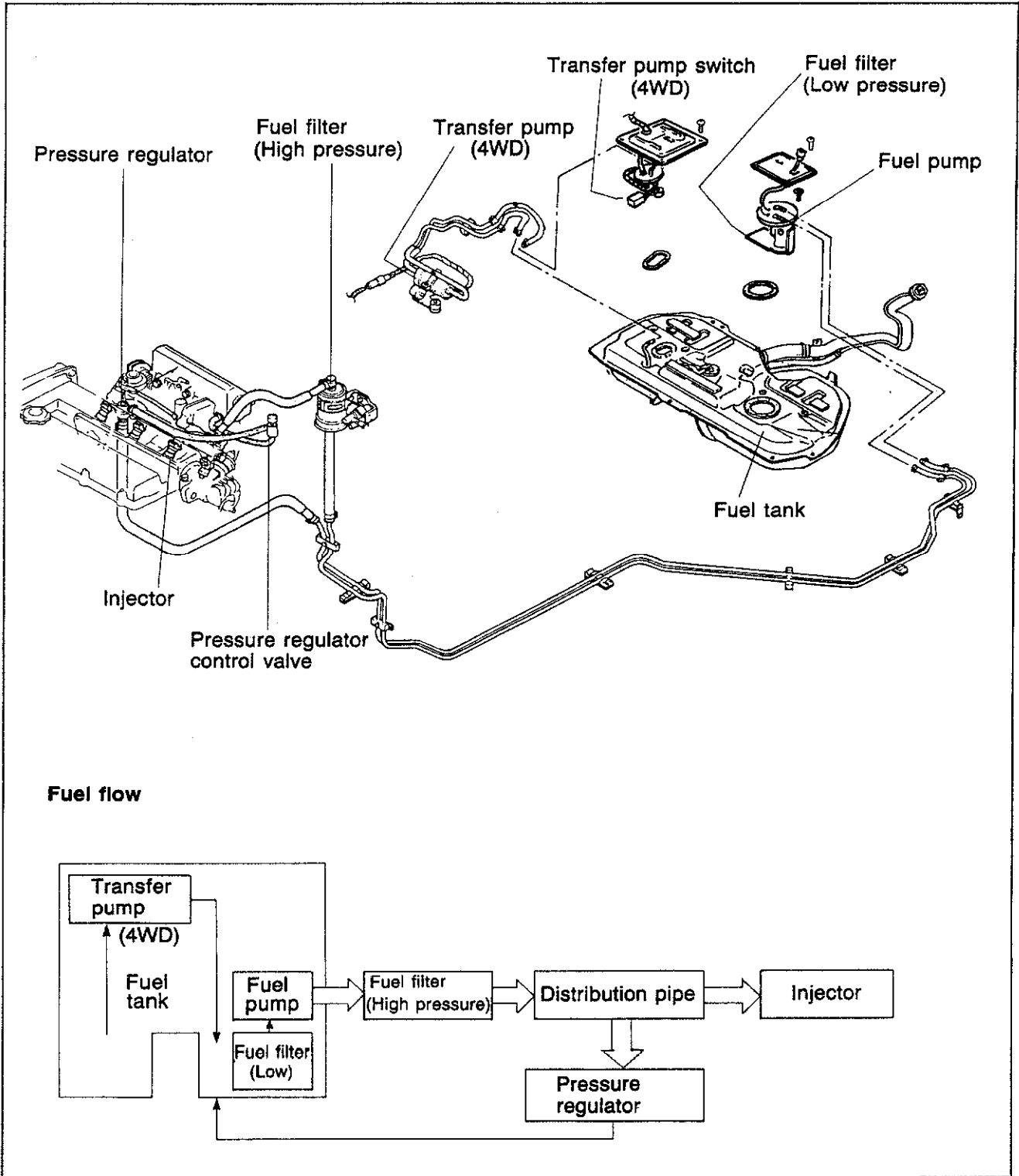

83U04B-053

This system supplies fuel for engine and controls the fuel pressure to maintain the required fuel injection amount to each injector.

This system consists of the fuel pump, transfer pump (only 4WD), pressure regulator, delivery pipe, fuel filters, and injectors.

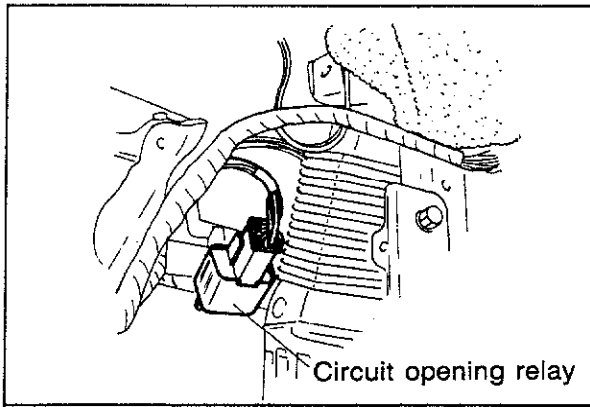

83U04B-054

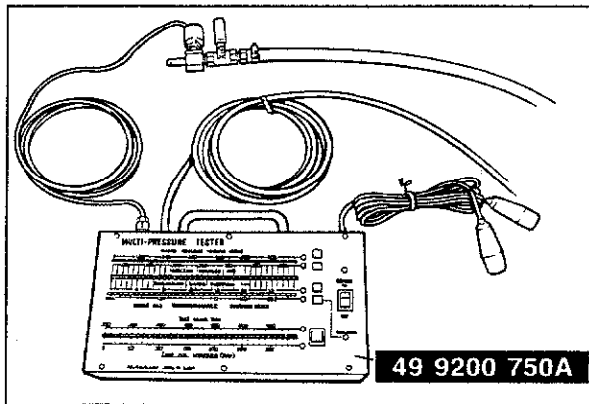

69G04A-098

## FUEL PRESSURE RELEASE AND SERVICING FUEL SYSTEM

Fuel in the fuel lines remains under high pressure even when the engine is not running.

- a) Before disconnecting any fuel line, release the fuel pressure from the fuel line to reduce the possibility of injury or fire.
  1. Start the engine.
  2. Disconnect the circuit opening relay connector.
  3. After the engine stalls, turn OFF the ignition switch.
  4. Connect the circuit opening relay connector.
- b) Use a rag as protection from fuel spray when disconnecting the hoses.  
Plug the hoses after removal.
- c) When inspecting the fuel system, use **SST**.

## MULTI-PRESSURE TESTER (49 9200 750A)

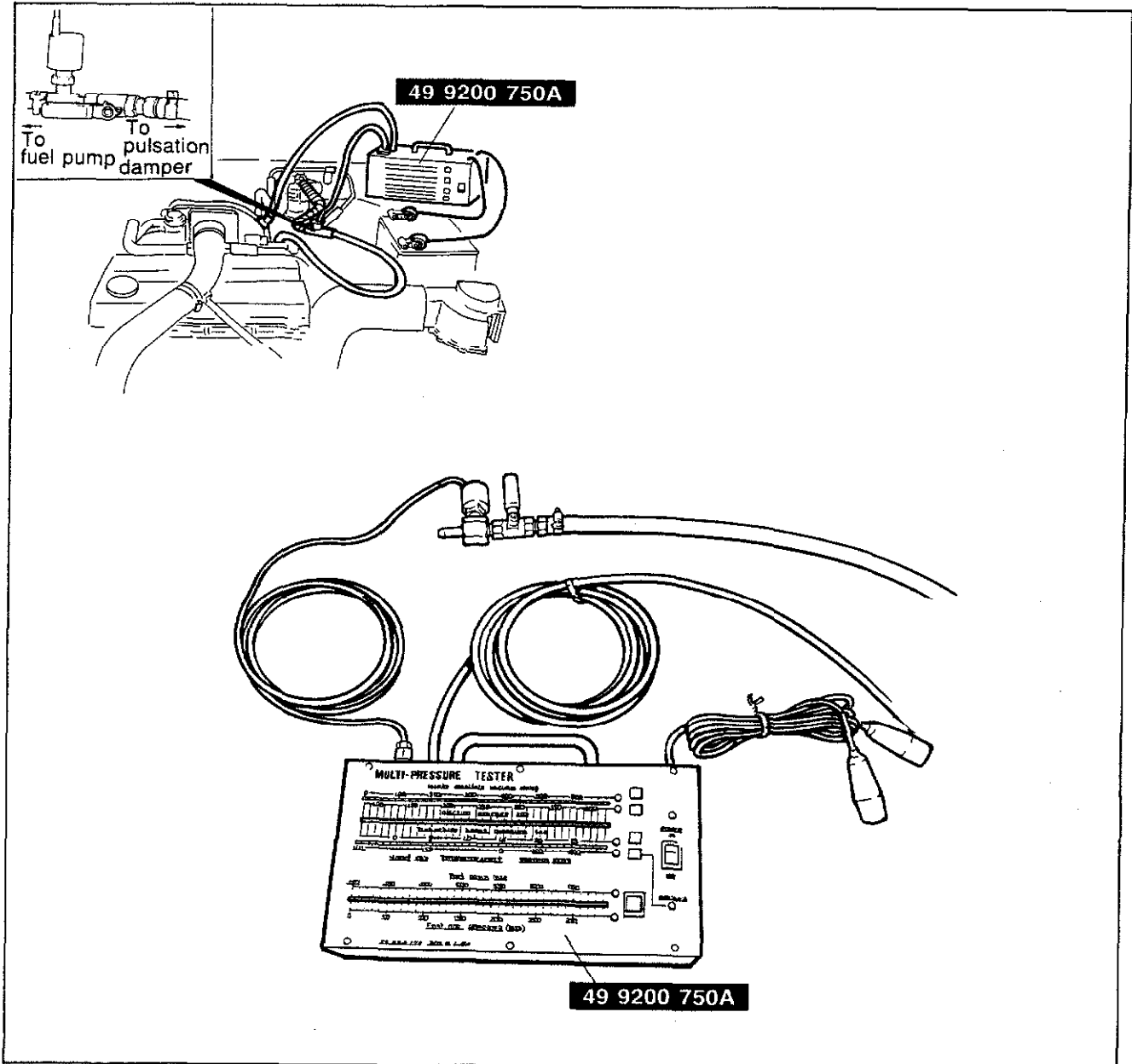

69G04A-099

The **MULTI-PRESSURE TESTER** (49 9200 750A) has been developed to check the fuel pressure and intake manifold vacuum. These can easily be inspected by setting the buttons on the tester.

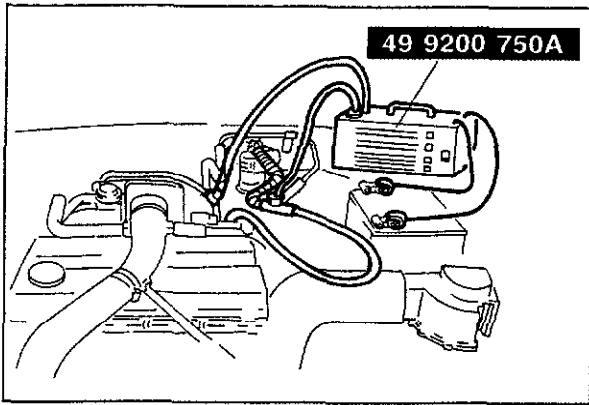

83U04B-055

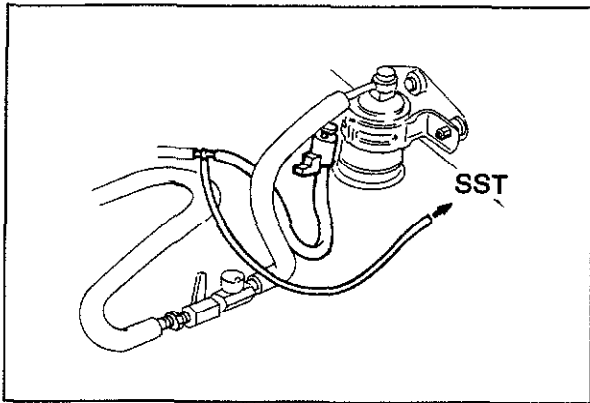

83U04B-056

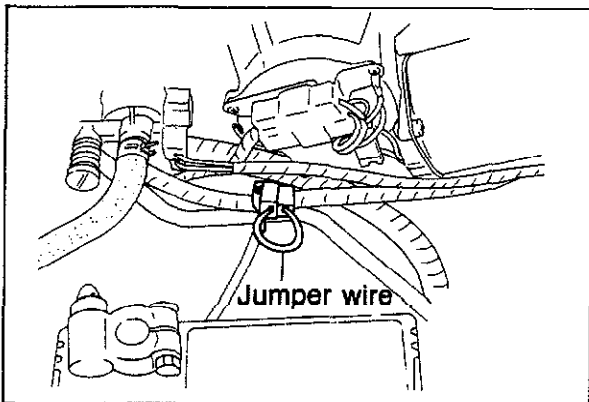

83U04B-057

## How to Connect Multi-Pressure Tester

### Warning

**Before connecting SST, release the fuel pressure from the fuel line to reduce the possibility of injury or fire. (Refer to page 4B—37)**

1. Disconnect the battery negative cable.
2. Disconnect the fuel main hose from the pressure regulator
3. Connect **SST** between fuel main hose and pressure regulator using adapter.

### Caution

**Do not reverse the adapter connection.**

4. Disconnect the vacuum hose from the pressure regulator control solenoid valve, and connect **SST** vacuum hose using a three-way joint.
5. Connect the battery negative cable.
6. Connect **SST** to the battery.

7. Connect the terminals of the test connector (yellow connector) with a jumper wire. Turn the ignition switch ON to operate the fuel pump.
8. Check for fuel leaks.

### Caution

**After checking fuel leakage, turn the ignition switch OFF and disconnect the jumper wire from the service connector.**

## TROUBLESHOOTING CHART

Before performing the following troubleshooting, check the condition of the wiring harness and connector.

SYMPTOM	POSSIBLE CAUSE								Engine control unit terminal voltage		
	Water thermo sensor	Air flow meter	Intake air thermo sensor	Throttle sensor (Variable resistor type)	Atmospheric pressure sensor	Oxygen sensor	Fuel pressure	Injector	3C	3E	3B
	4B-82	4B-79	4B-79	4B-80	4B-84	4B-83	4B-41	4B-43	4B-76,77		
Hard start or won't start (Crank OK)	3						1	2	5	6	4
Engine stall	While warming up	3	4	5		6		1	2	7	8
	After warming up	3	4	5		6	7	1	2	8	9
Rough idle	While warming up	3	4	5		6		1	2	7	8
	After warming up	3	4	5		6	7	1	2	8	9
Poor acceleration, hesitation or lack of power	4	5		1				2	3	6	7
Runs rough on deceleration	2							1	3	4	
Excessive fuel consumption	3	4	5	6	7	8	1	2	9	10	
Afterburn in exhaust system	3	4	5				1	2	6	7	
Engine stalls or rough after hot starting	3		4				1	2	5	6	
Falls emission test	3	4	5	6	7	8	1	2	9	10	

83U04B-058

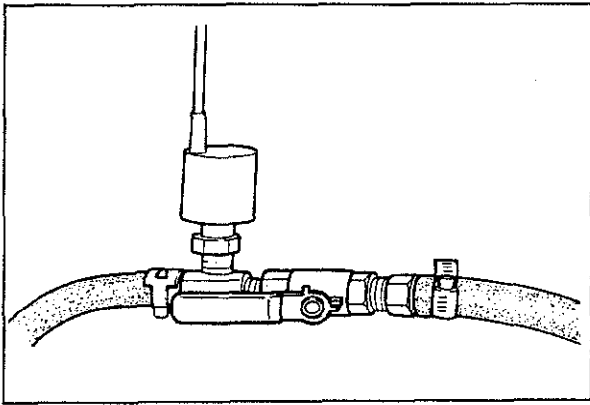

83U04B-059

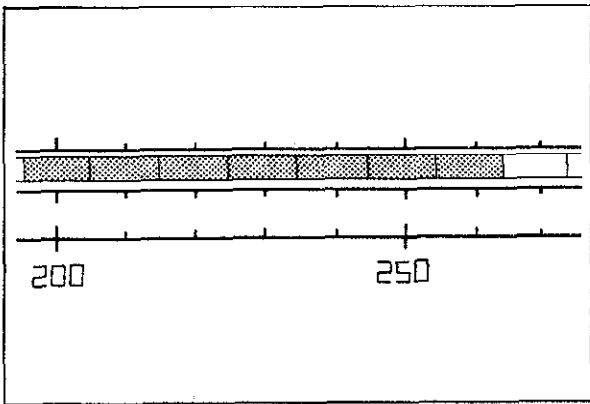

83U04B-060

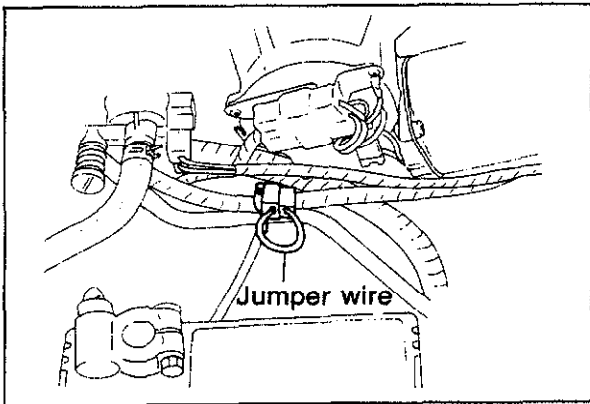

83U04B-061

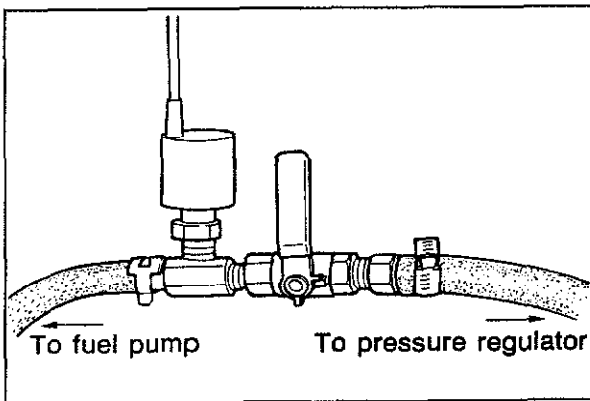

83U04B-062

## FUEL PRESSURE

### Note

- a) When inspecting fuel pressure, use SST. (Refer to page 4B—39)
- b) Warm up the engine to normal operating temperature.

### Injection Pressure

1. Set the lever on the adapter as shown in the figure.
2. Run the engine and measure the injection pressure at various speeds.

**Injection pressure: Approx. 240—279 kPa (2.45—2.85 kg/cm<sup>2</sup>, 34.8—40.5 psi)**

3. If not within specification, check the fuel pump pressure, fuel line pressure, and injector (Refer to page 4B—47)

### Fuel Pump Pressure

1. Connect the terminals of the test connector (yellow connector) with a jumper wire.
2. Turn the ignition switch ON to operate the fuel pump.
3. Move the lever on the adapter as shown in the figure.
4. Check the fuel pump pressure.

**Fuel pump pressure: 441—588 kPa (4.5—6.0 kg/cm<sup>2</sup>, 64.0—85.3 psi)**

5. If the fuel pump pressure is not within specification, check the followings.

#### No pressure

**Fuel pump operation (Refer to page 4B—43)**

#### Low pressure

**Fuel pump feeding capacity (Refer to page 4B—43)**

#### High pressure

**Replace the fuel pump**

6. After checking the fuel pump pressure, disconnect the jumper wire from the service connector.

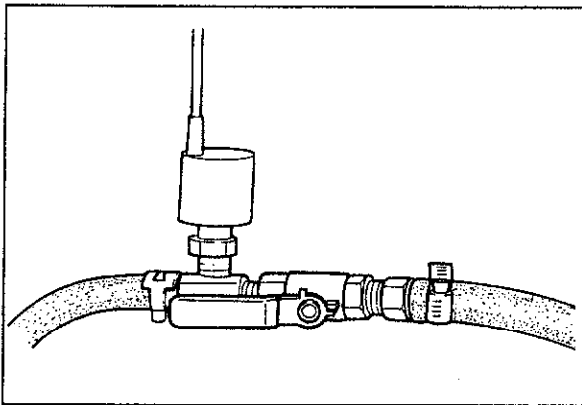

83U04B-063

## Fuel line Pressure

1. Start the engine and run it idle.
2. Move the lever on the adapter as shown in the figure.
3. Check the fuel line pressure.

**Fuel line pressure: Approx. 167—216 kPa  
(1.7—2.2 kg/cm<sup>2</sup>, 24.1—31.3 psi)**

4. If not within specification, check the vacuum hose.

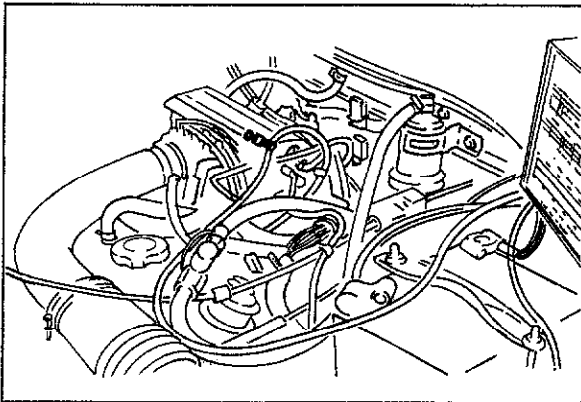

83U04B-064

5. Disconnect a vacuum hose of pressure regulator.
6. Check the fuel line pressure.

**Fuel line pressure: 240—279 kPa  
(2.45—2.85 kg/cm<sup>2</sup>, 34.8—40.5 psi)**

7. If not within specifications, replace the pressure regulator.
8. Connect the vacuum hose to pressure regulator.



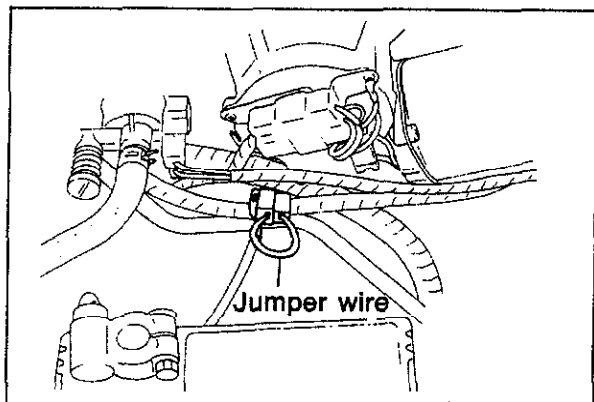

83U04B-065

## INSPECTION

### Fuel Pump (Operation Test)

1. Connect a jumper wire to the test connector (Yellow).
2. Open the fuel tank lid, and fuel filler cap.
3. Turn the ignition switch ON.
4. Check that the fuel pump operation sound.
5. Shut the fuel filler cap, and fuel tank lid.

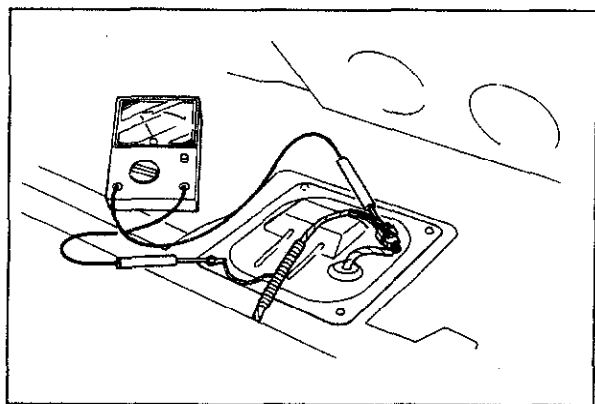

83U04B-066

6. If operation sound is not produced, check the voltage at the fuel pump connector.

### Voltage: 12V

(IG: ON, Voltmeter [GR and B] connected)

7. If the voltage is normal, replace the fuel pump.

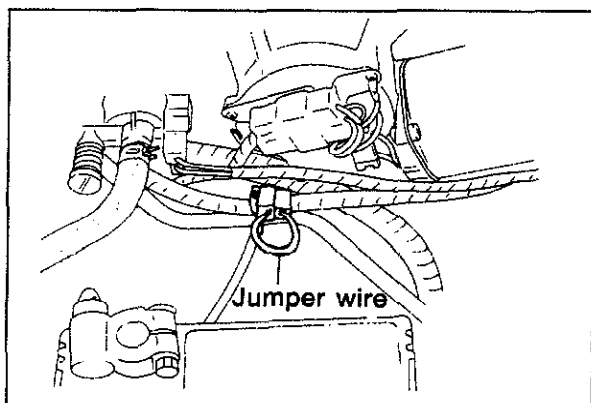

83U04B-067

### Fuel pump (Volume test)

#### Warning

Before performing following procedures, release the fuel pressure to reduce the possibility of injury or fire. (Refer to page 4B—37)

1. Connect a jumper wire to test connector (Yellow connector).
2. Disconnect the fuel return hose from fuel return pipe.
3. Turn the ignition switch ON for 10 seconds, and check the feeding capacity with graduated cylinder.

#### Feeding capacity:

220—380 cc (13.4—23.2 cu-in)/10 sec when fuel pressure at 250 kPa (2.55 kg/cm<sup>2</sup>, 36.3 psi)

4. If not within specification, check the fuel filter, and fuel line.

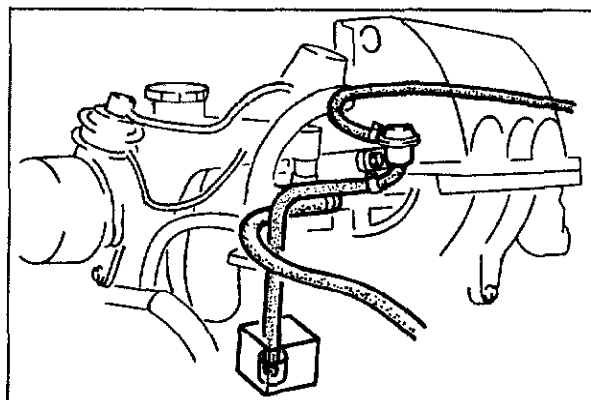

83U04B-068

## TRANSFER PUMP CONTROL SYSTEM

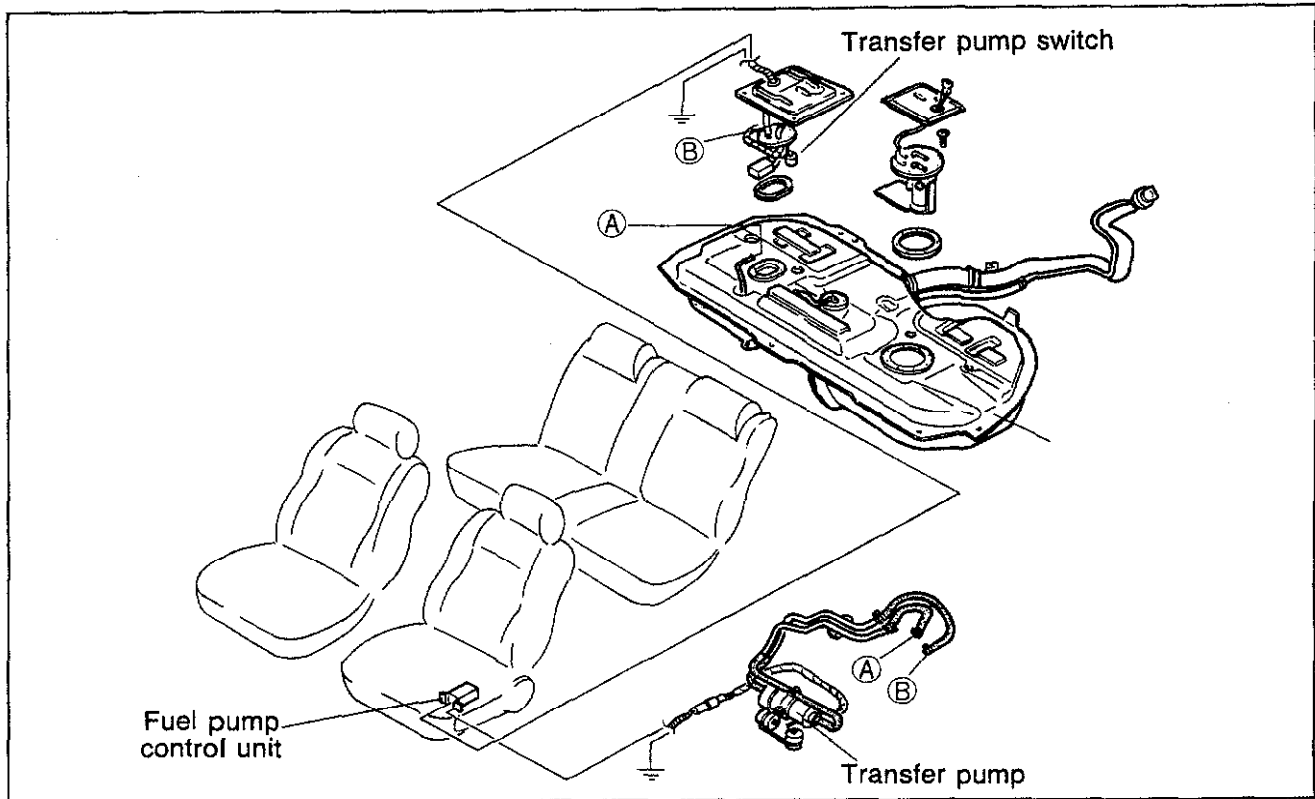

63G04C-351

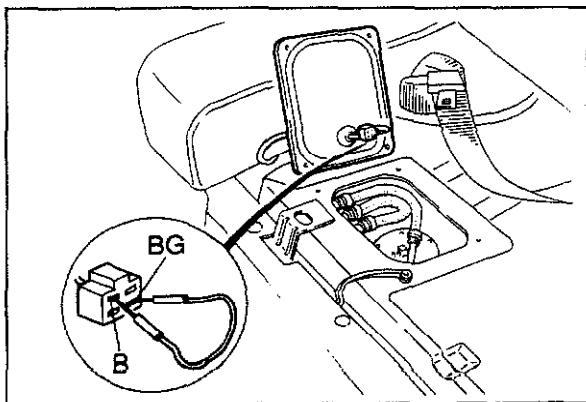

83U04B-069

### Inspection

1. Remove the rear seat cushion.
2. Remove attaching screws and cover.
3. Turn the ignition switch ON.
4. Disconnect the fuel tank gauge unit connector, then short or open the (BG) and (B) terminals of the fuel tank gauge unit connector using a jumper wire, and check the transfer pump operation.

Terminals	Transfer pump operation
Short	Stop
Open	Run

### Note

**The transfer pump will not operate until 10 seconds after opening the (BG) and (B) terminals.**

5. If the operation is not correct, check the following parts.  
 Transfer pump  
 Fuel pump control unit  
 Transfer pump switch

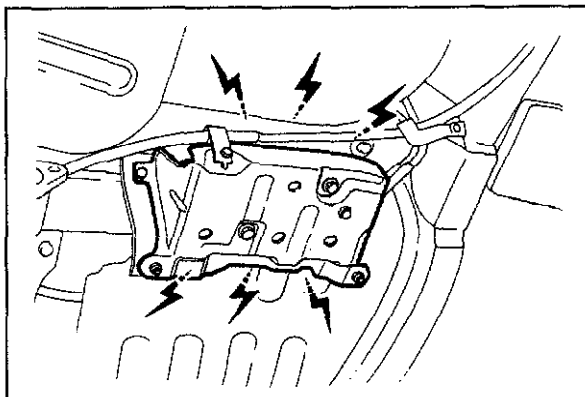

83U04B-070

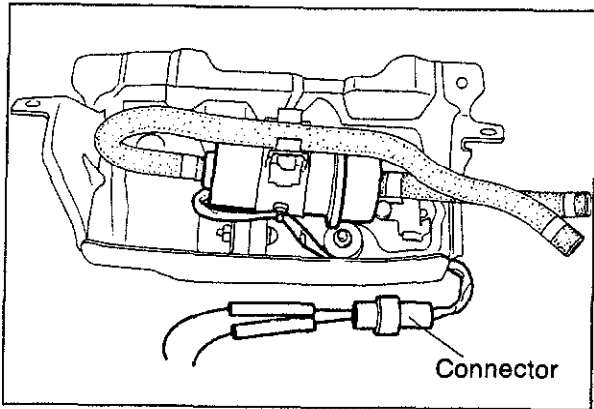

63G04C-354

## Transfer Pump Inspection

Measure the resistance with the transfer pump connector disconnected.

**Resistance: 8 Ω**

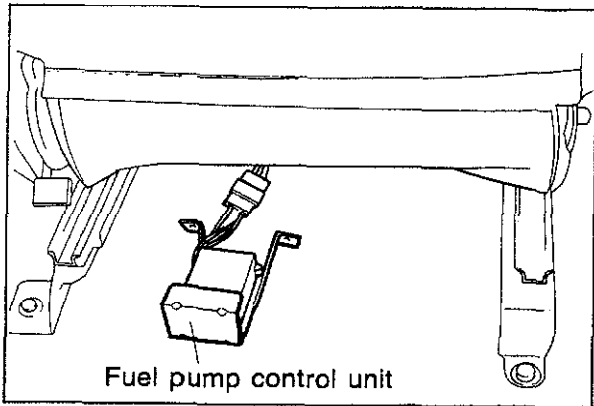

63G04C-356

## Fuel Pump Control Unit Inspection

1. Remove the control unit under the driver's seat.

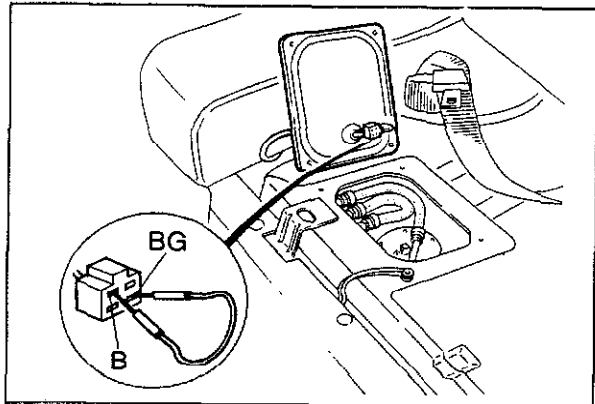

83U04B-071

2. Remove the rear seat cushion.
3. Disconnect the fuel tank gauge unit connector.
4. Remove attaching screws and cover.
5. Turn the ignition switch ON.
6. Short or open the (BG) and (B) terminals of the fuel tank gauge unit connector, and check the voltage (B) and (BY) terminals of the fuel pump control unit.

Terminals	Voltage V	
	B	BY
Short	0	0
Open	0	12

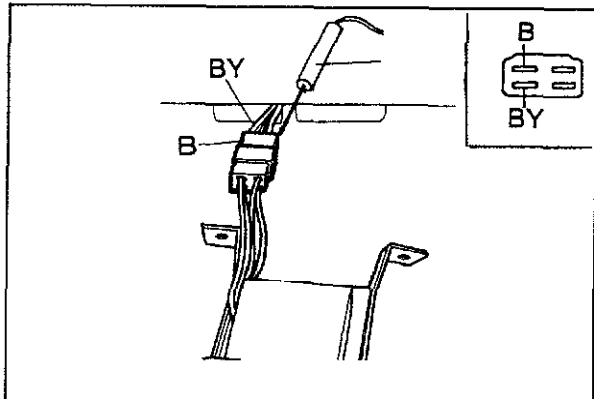

83U04B-072

7. If the voltage is not within specifications, replace the fuel pump control unit.

### Note

**12V will not be indicated at the (BY) terminal until 10 seconds after opening the terminals of the fuel tank gauge unit connector.**

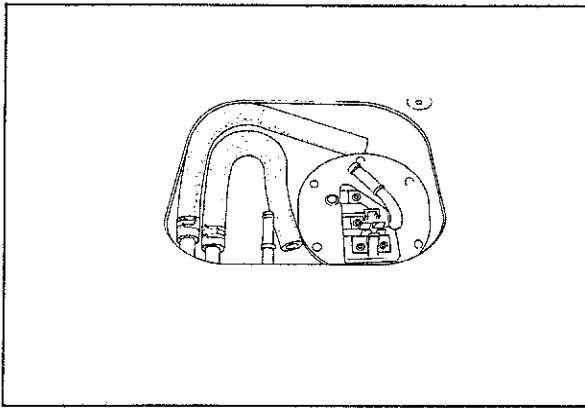

83U04B-073

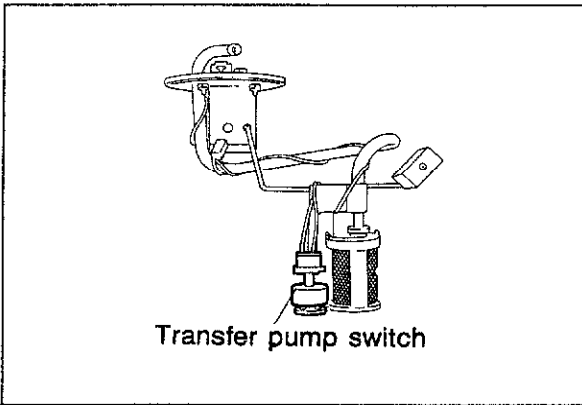

Transfer pump switch

83U04B-074

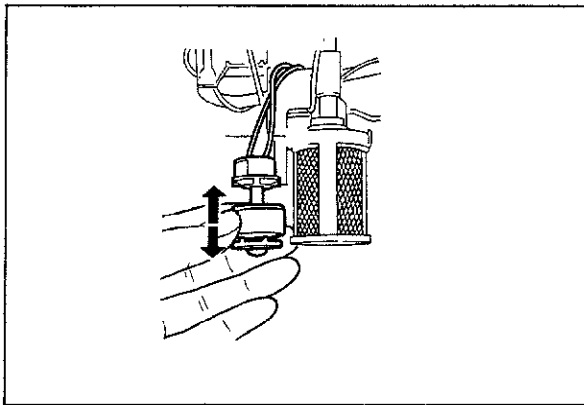

83U04B-075

## Transfer Pump Switch Removal

### Warning

**Before performing following procedures, release the fuel pressure to reduce the possibility of injury or fire. (Refer to page 4B—37)**

1. Remove the filler cap.
2. Remove the rear seat cushion.
3. Remove attaching screws and cover.
4. Disconnect the fuel hoses and plug them.
5. Remove the fuel tank gauge unit.

### Inspection

1. Check the continuity between the (B) and (BG) terminals with the float up and down.

Float	Continuity
Up	No
Down	Yes

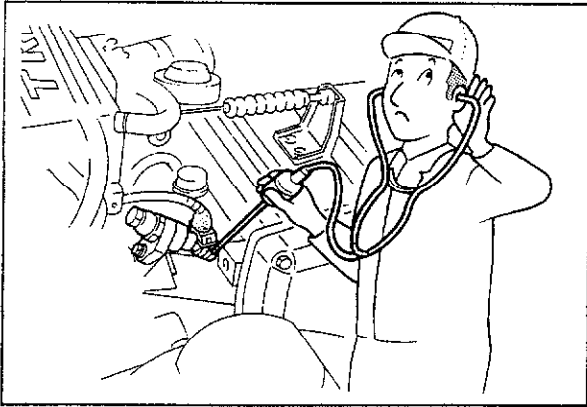

83U04B-076

## Injector (On-vehicle inspection)

1. Warm up the engine and run at idle.
2. Check the operating sound of the injector, using a sound scope. Check that operating sounds are produced from each injector at idle and at acceleration.
3. If operating sound is not produced, check the followings.
  - Wiring harness
  - Injector resistance
  - Engine control unit terminal voltage of 3C, 3E. (Refer to page 4B—77)

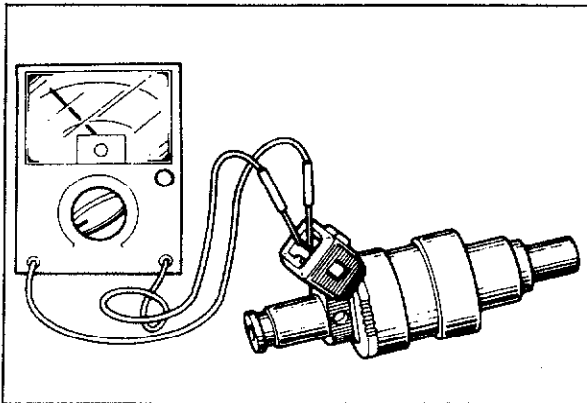

83U04B-077

## Injector (Resistance)

### Warning

**Before performing following procedures, release the fuel pressure to reduce the possibility of injury or fire. (Refer to page 4B—37)**

1. Remove the injector from the engine. (Refer to page 4B—50)
2. Check the resistance of the injector.

**Resistance: 12—16 Ω**

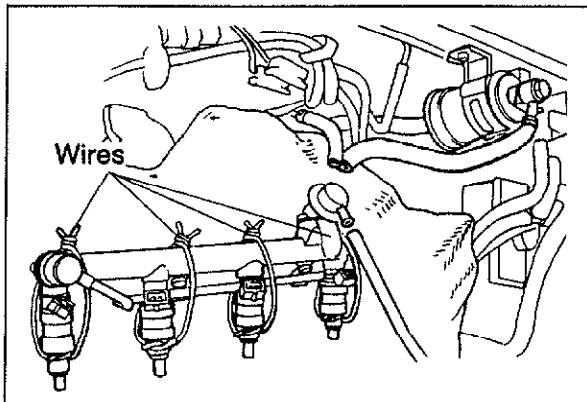

83U04B-078

## Injector (Leak test)

### Warning

**Before performing following procedures, release the fuel pressure to reduce the possibility of injury or fire. (Refer to page 4B—37)**

1. Remove the delivery pipe, injector, and pressure regulator. (Refer to page 4B—50)
2. Affix the injectors to the distribution pipe with wire.

### Caution

**Affix the injectors firmly to the distribution pipe so no movement of the injectors is possible.**

3. Connect the distribution pipe assembly between the fuel filter and the return pipe.
4. Connect the return hose to the pressure regulator.
5. Connect the negative terminal of the battery.

### Warning

**Be extremely careful when working with fuel; always work away from sparks or open flames.**

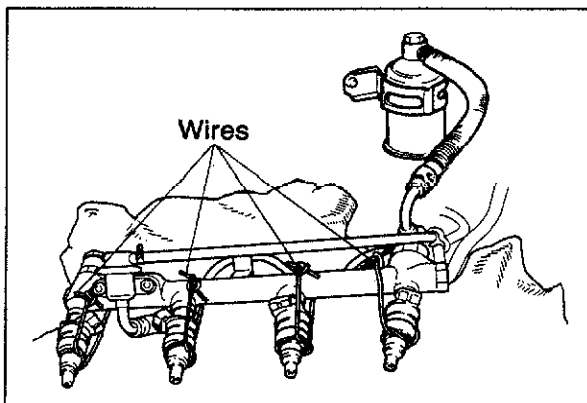

83U04B-079

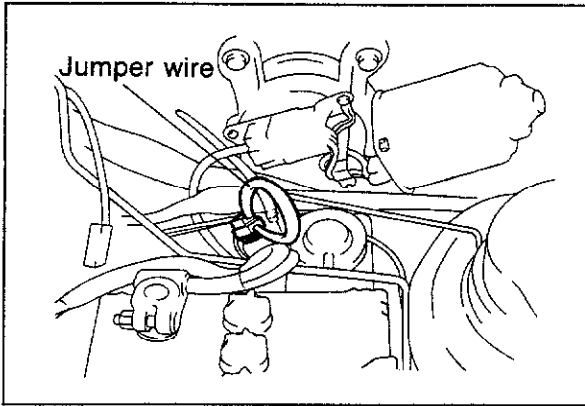

83U04B-080

6. Connect a jumper wire to the test connector (Yellow terminal).
7. Turn the ignition switch ON.
8. Check that fuel does not leak from injector.

**Note**

**After 5 minutes a very slight amount of fuel leakage from the injector is acceptable.**

9. If fuel leaks, replace the injector.

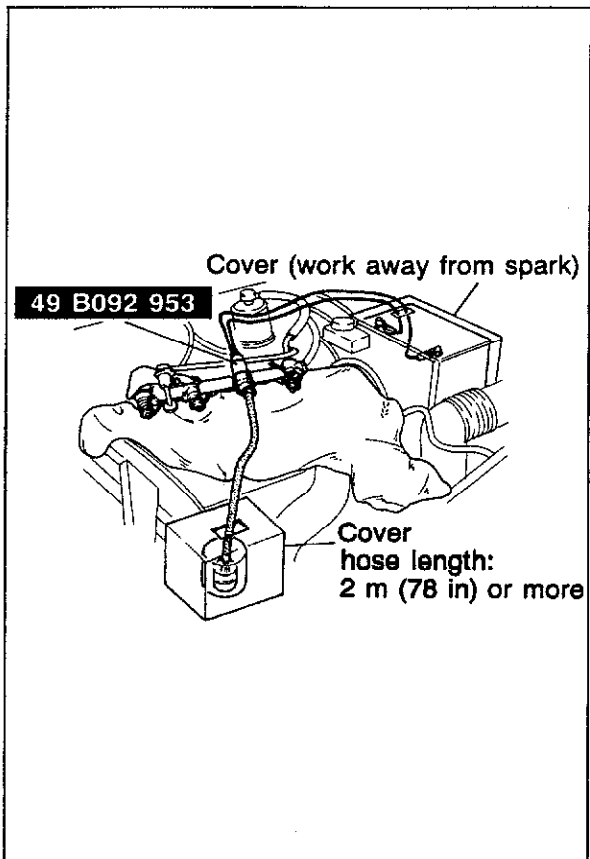

83U04B-081

**Injector (Volume test)**

1. Connect a suitable vinyl hose to the injector and place the hose in the container, or graduated glass etc.

**Note**

**The hose should be 2 m (78 in) or more**

2. Connect the terminals of the fuel pump service connector with a jumper wire.

**Warning**

**Be extremely careful when working with fuel; always work away from sparks or open flames.**

3. Apply battery voltage to each injector, using the SST.
4. Turn the ignition switch ON.
5. Check the injection volume.

**Specification: 66—82 cc (4.0—5.0 cu in)/15 sec.**

6. If not correct, replace the injector.

## REPLACEMENT AND INSTALLATION Fuel Pump

### Warning

Before performing the following procedures, release the fuel pressure to reduce the possibility of injury or fire.  
(Refer to page 4B—37)

1. Remove the filler cap.
2. Remove rear seat cushion.
3. Remove attaching screws and cover.
3. Disconnect the fuel main, and return hoses and plug them to prevent fuel leakage.

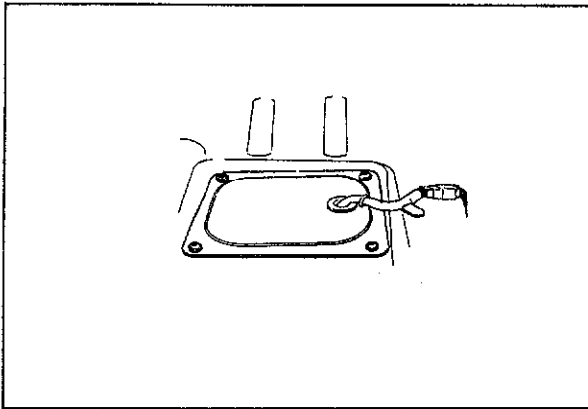

83U04B-082

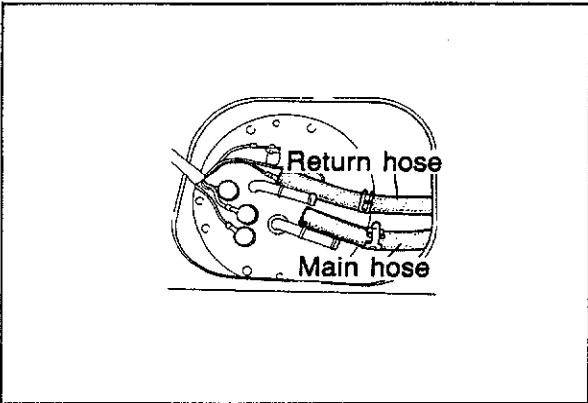

83U04B-083

4. Remove the fuel pump and fuel tank gauge unit assembly.

### Warning

Use of fire or smoking is strictly prohibited while working on the fuel system.

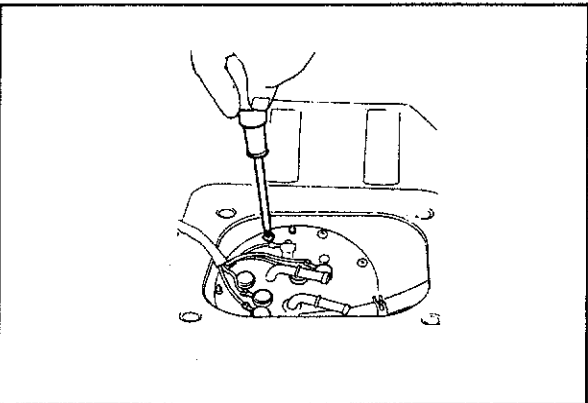

83U04B-084

5. Replace the fuel pump.
6. Install the fuel pump and fuel tank gauge unit assembly in the reverse order of removal.

### Caution

Secure the fuel pump terminals and fuel hose.

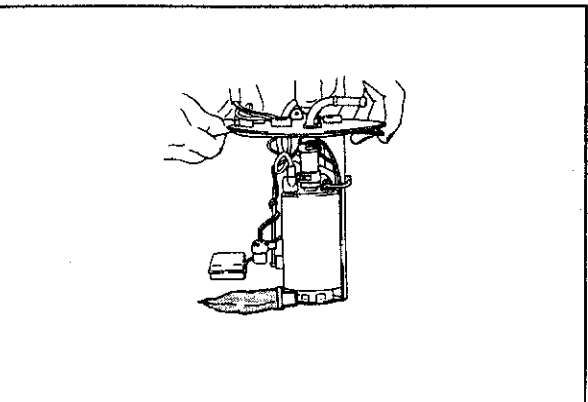

83U04B-085

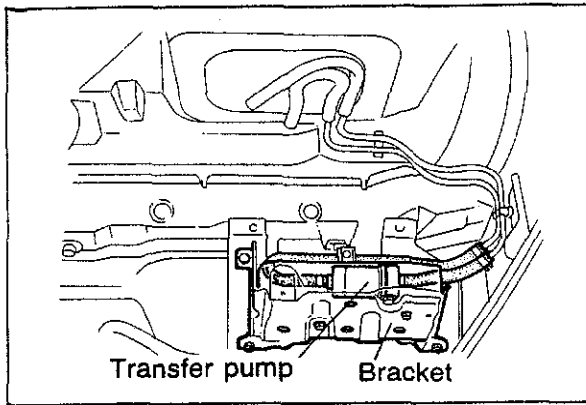

83U04B-086

## Transfer Pump

### Warning

**Before performing the following procedures, release the fuel pressure to reduce the possibility of injury or fire. (Refer to page 4B—37)**

1. Remove the filler cap.
2. Remove the transfer pump bracket under the vehicle.
3. Disconnect the fuel hoses.
4. Disconnect the *connector*.
5. Install in the reverse order of removal.

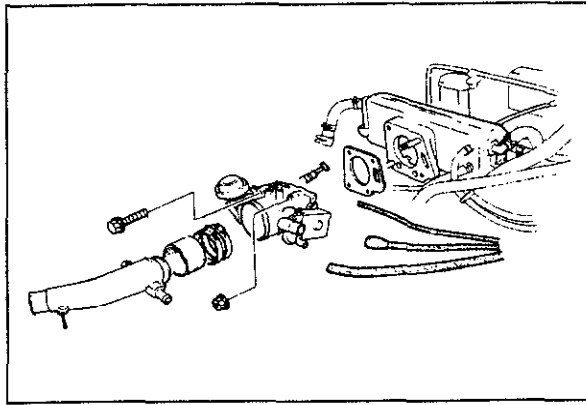

83U04B-087

## Pressure Regulator

1. Remove the throttle body. (Refer to page 4B—29)

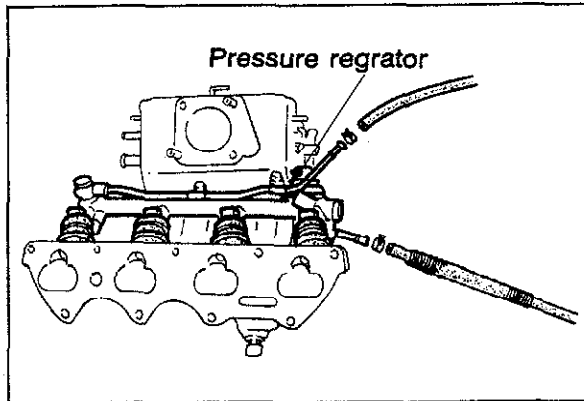

83U04B-088

2. Disconnect the fuel main hose and return hose.
3. Remove the pressure regulator.
4. Install the pressure regulator, and throttle body in reverse order of removal.

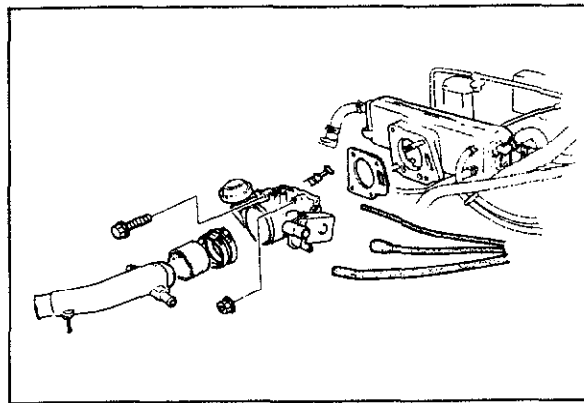

83U04B-089

## Injector

1. Remove the throttle body. (Refer to page 4B—29)



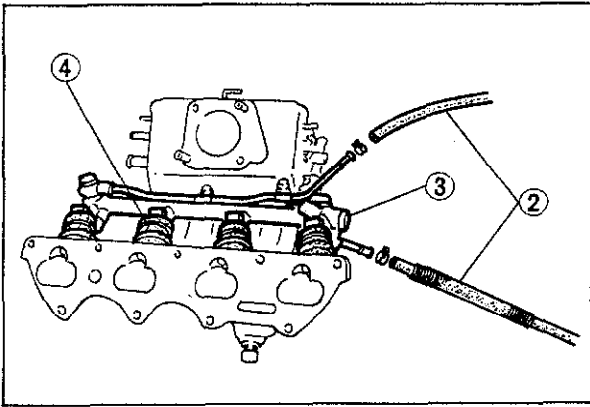

83U04B-090

2. Disconnect the fuel main hose and return hose.
3. Remove the delivery pipe.
4. Remove the injector.
5. Install the injector, delivery pipe, throttle body in the reverse order of removal.

**Tightening torque:**

**Delivery pipe: 18.6—25.5 N·m  
(1.9—2.6 m·kg, 13.7—18.8 ft·lb)**

**Note**

- a) O-ring of injector is not reuseable.
- b) When install the injector, apply the gasoline on the O-ring.

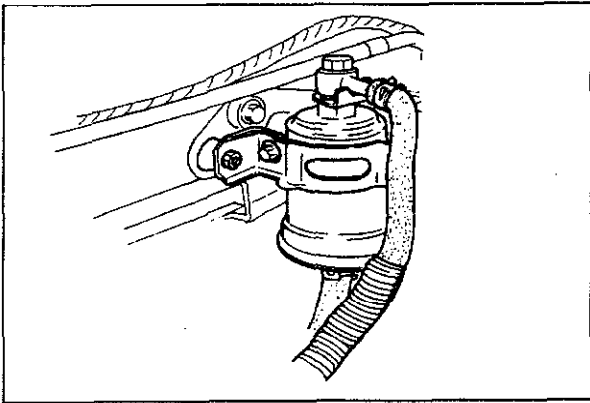

83U04B-091

**Fuel Filter (High Pressure)**

The fuel filter should be replaced at intervals, following the maintenance schedule.

To replace the fuel filter, proceed as follows:

1. Disconnect the fuel hoses.
2. Remove the fuel filter with the bracket.
3. Install a new filter and connect the fuel hoses.

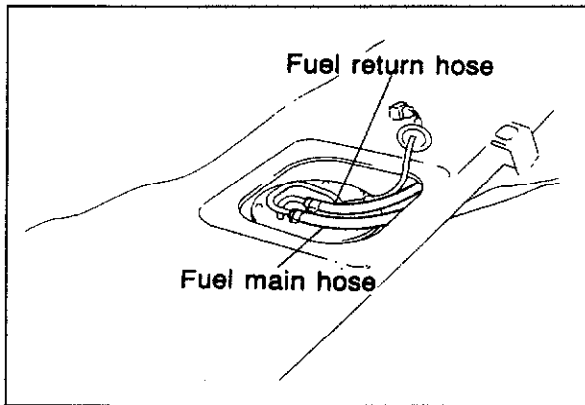

83U04B-092

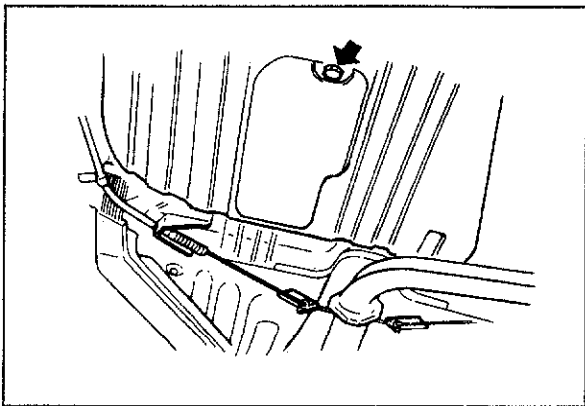

83U04B-093

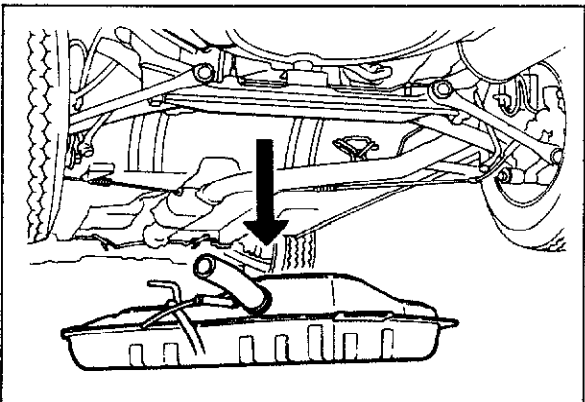

63U04B-068

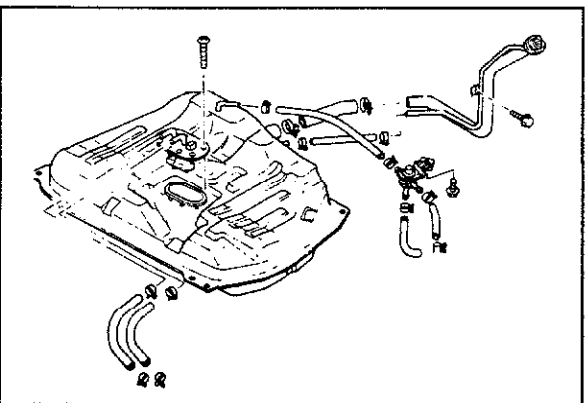

83U04B-094

## FUEL TANK (2WD) Removal

### Warning

**Before performing following procedures, release the fuel pressure to reduce the possibility of injury or fire. (Refer to page 4B—37)**

1. Remove the rear seat cushion.
2. Remove the cover and disconnect the fuel tank gauge unit connector.
3. Disconnect the fuel main and return hoses.
4. Raise the vehicle and support it with safety stands.
5. Remove the drain plug and drain the fuel.

### Warning

**a) When repairing the fuel tank, clean the fuel tank thoroughly with steam to remove all explosive gas.**

**b) Use of fire is strictly prohibited while working on the fuel tank.**

6. Disconnect the other hoses.
7. Remove the fuel tank.

## Installation

Install in reverse order of removal and be careful of the following;

1. Make sure to connect the hoses in the correct positions.
2. Fill tank with fuel and Check for leaks.

**FUEL TANK (4WD)**

**Warning**

- a) When repairing the fuel tank, clean the fuel tank thoroughly with steam to remove all explosive gas.
- b) Use of fire is strictly prohibited while working on the fuel tank.

**Removal and Installation**

- 1. Remove in the sequence shown in the figure.
- 2. Install in the reverse order of removal and be careful of the following;
  - a) Be sure to connect the hoses in the correct positions.
  - b) Check for leaks.

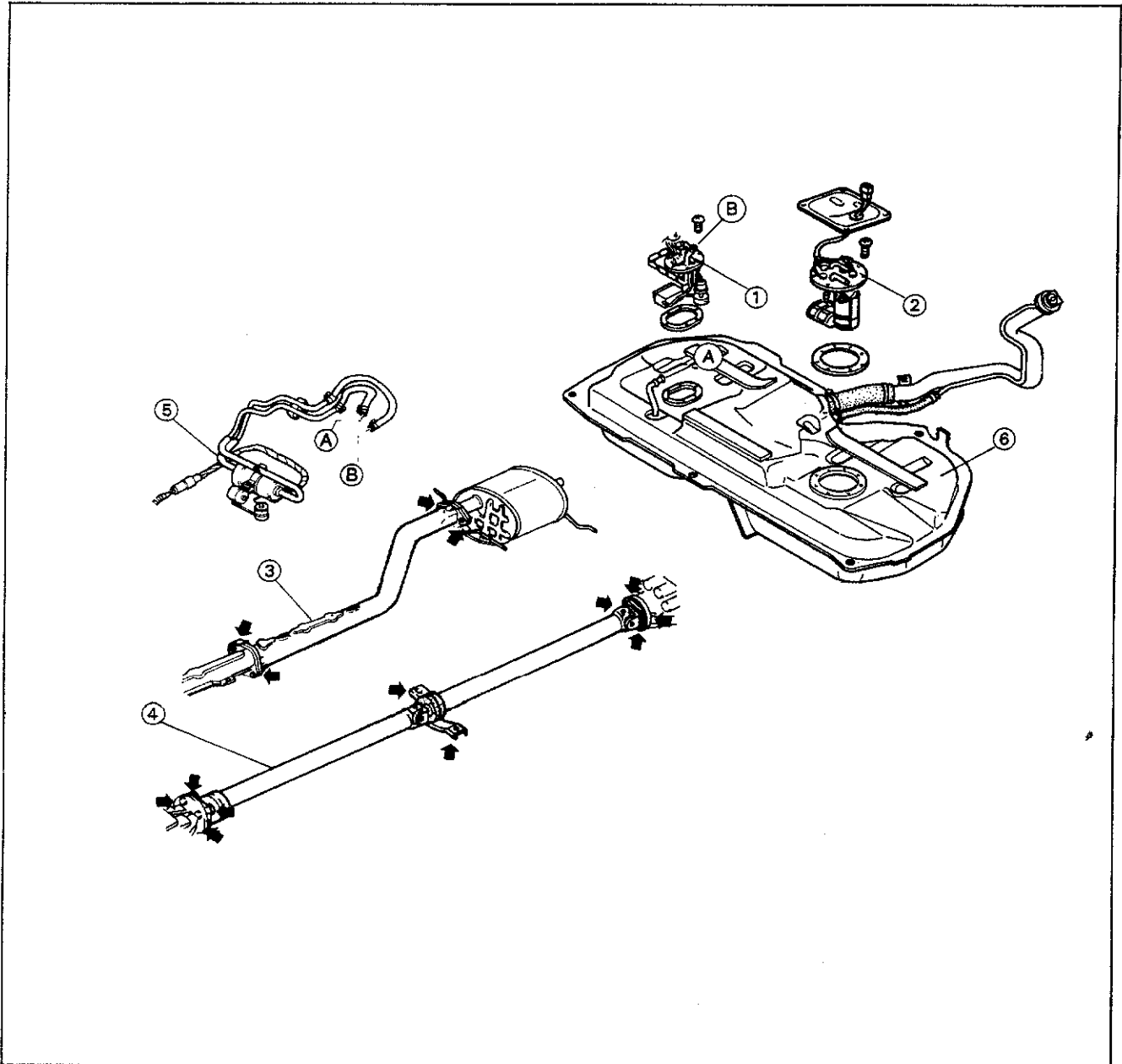

83U04B-095

1. Fuel tank gauge unit  
2. Fuel tank gauge unit

3. Exhaust pipe  
4. Propeller shaft

5. Transfer pump  
6. Fuel tank

## PRESSURE REGULATOR CONTROL (PRC) SYSTEM

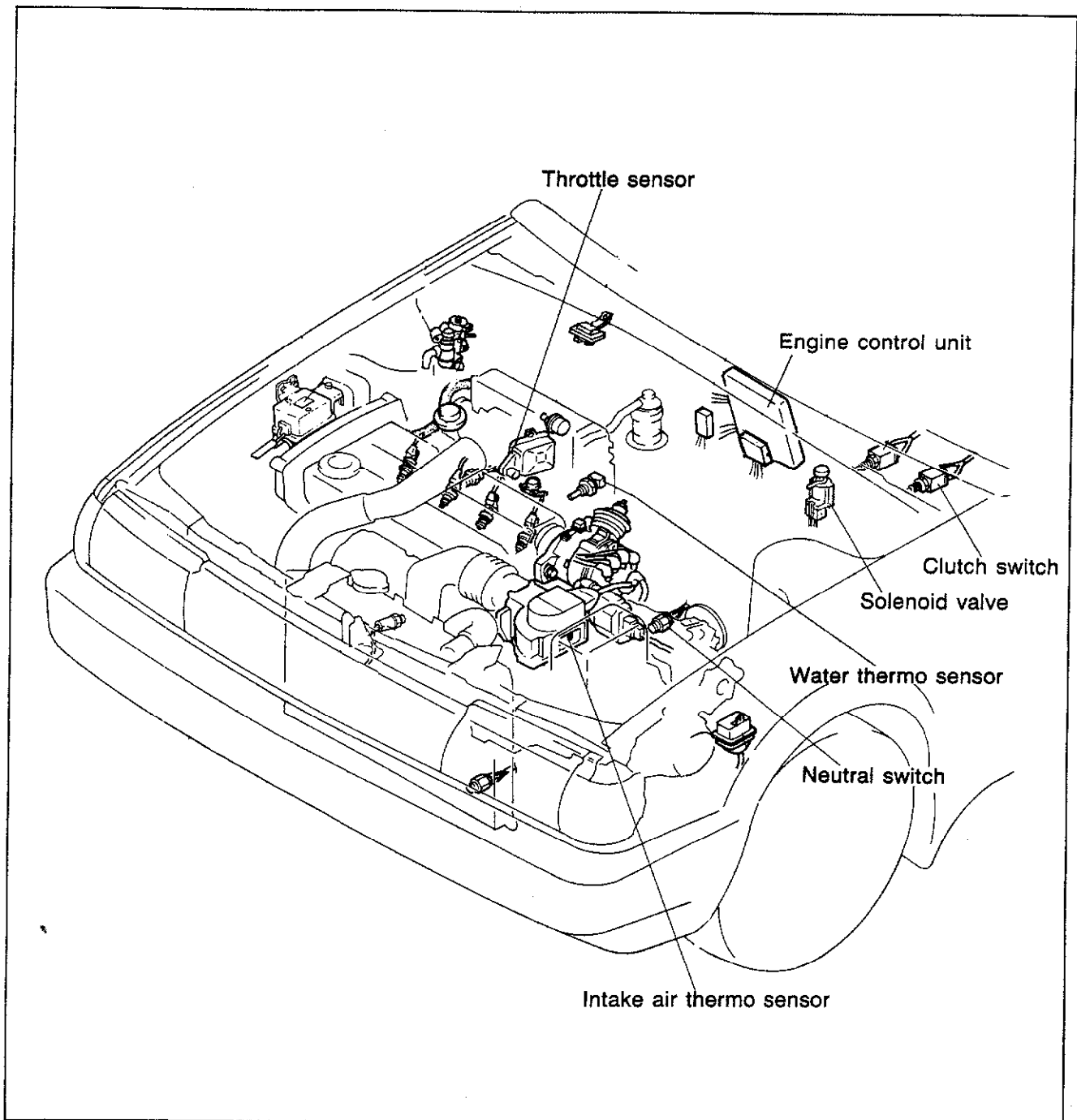

83U04B-096

To prevent percolation of the fuel during idle for a specified period after the engine is re-started, vacuum is cut to pressure regulator and the fuel pressure is increased.

**Specified time: Approx. 180 sec**

**Operating condition: Coolant temperature — above 90°C (158°F)**

**Intake air temperature — above 58°C (136°F)**

<p style="text-align: center;"><b>POSSIBLE CAUSE</b></p> <p style="text-align: center;"><b>PAGE</b></p> <p style="text-align: center;"><b>SYMPTOM</b></p>	Water thermo sensor	Intake air thermo sensor	System inspection	Vacuum signal	Electrical signal	Solenoid valve	Control unit terminal voltage	
	4B-82	4B-79	4B-55	4B-56	4B-56	4B-57	2K 4B-77	
<b>Checking order</b>	5	6	1	2	3	4	7	

83U04B-097

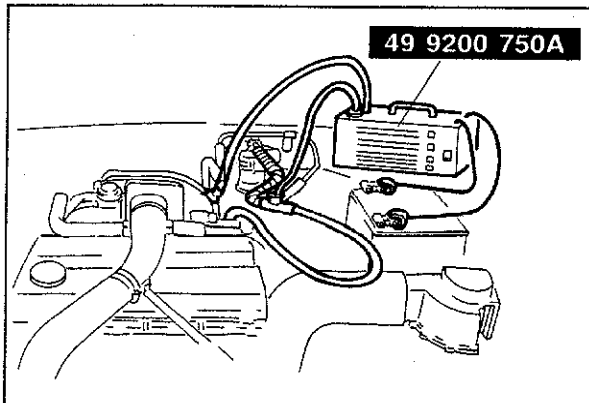

83U04B-098

### System Inspection

1. Connect **SST** to the engine. (Refer to page 4B-38)
2. Start the engine.

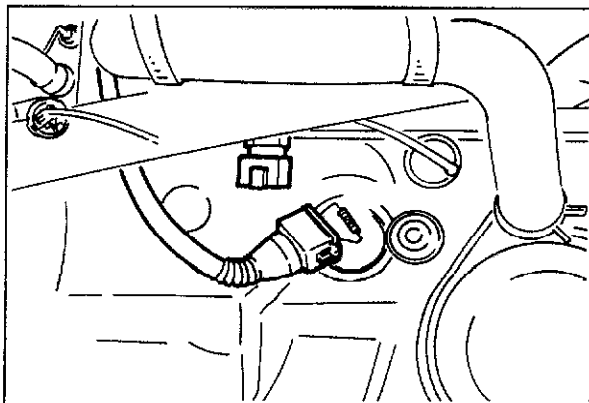

83U04B-099

3. Warm up the engine to normal operating temperature and stop the engine.
4. Disconnect the water thermo sensor connector, then connect a resistor (**200 Ω**) to the sensor connector.
5. Remove the air cleaner upper cover assembly, and heat up the intake air thermo sensor above 60°C (140°F).

# 4B PRESSURE REGULATOR CONTROL (PRC) SYSTEM

Operating time	Fuel line pressure kPa (kg/cm <sup>2</sup> , psi)
After starting for 180 sec	245—279 (2.45—2.85, 35.6—40.5)
After 180 sec	167—216 (1.7—2.2, 24.2—31.3)

83U04B-100

6. Restart the engine.
7. Check the fuel line pressure and operating times as shown in the chart.
8. If not correct, check the water thermo sensor, intake air thermo sensor, solenoid valve, and control unit.

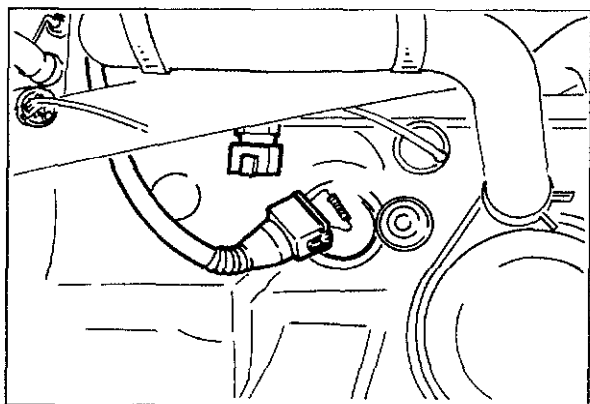

83U04B-101

## Vacuum Signal

1. Disconnect the water thermo sensor connector, then connect a resistor (**200 Ω**) to the sensor connector.
2. Remove the air cleaner upper cover assembly, and heat up the intake air thermo sensor above 60°C (140°F).
3. Disconnect the vacuum hose from the pressure regulator, and place a finger over the port opening.

Operating time	Vacuum condition
After starting for 180 sec	No vacuum
After 180 sec	Vacuum

83U04B-102

4. Check for vacuum when starting the engine.
5. If not correct, check the solenoid valve and electrical signal.
6. Connect the vacuum hose to the pressure regulator.

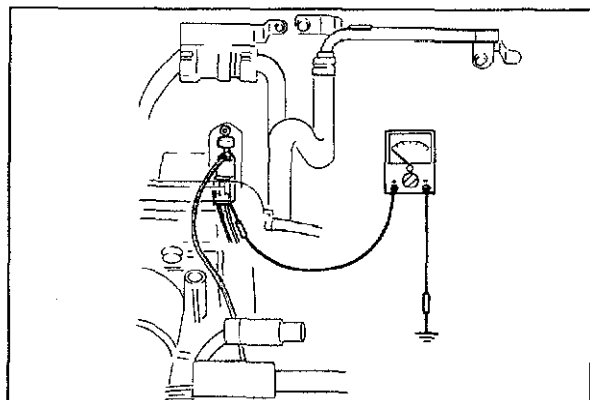

83U04B-103

## Electrical Signal

1. Disconnect the water thermo sensor connector, then connect a resistor (**200 Ω**) to the sensor connector.
2. Remove the air cleaner upper cover assembly, and heat up the intake air thermo sensor above 60°C (140°F).
3. Connect a voltmeter to the PRC solenoid valve (LB).

Operating time	Voltage
After starting for: 180 sec	below 2.5 V
After 180 sec	approx 12V

83U04B-104

4. Check the voltage when starting the engine.
5. If not correct, check the engine control unit terminal voltage (Refer to page 4B—77)

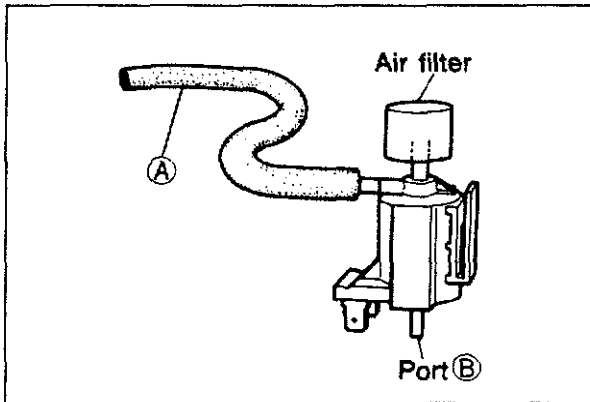

69G04A-134

### PRC Solenoid Valve Inspection

1. Disconnect the vacuum hose from the solenoid valve and vacuum pipe.
2. Blow through the solenoid valve from vacuum hose (A).
3. Check that air passes through the solenoid valve and flows from port (B).

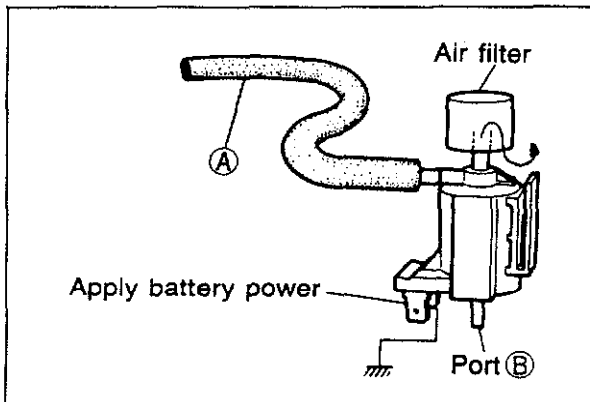

83U04B-104

4. Disconnect the solenoid valve connector.
5. Connect 12V and a ground to the terminals of the solenoid valve.
6. Blow through the solenoid valve from the vacuum hose (A).
7. Check that air passes through the solenoid valve and flows from the air filter.
8. If not correct, replace the solenoid valve.
9. Connect the vacuum hoses, and connector.

## TURBOCHARGING SYSTEM

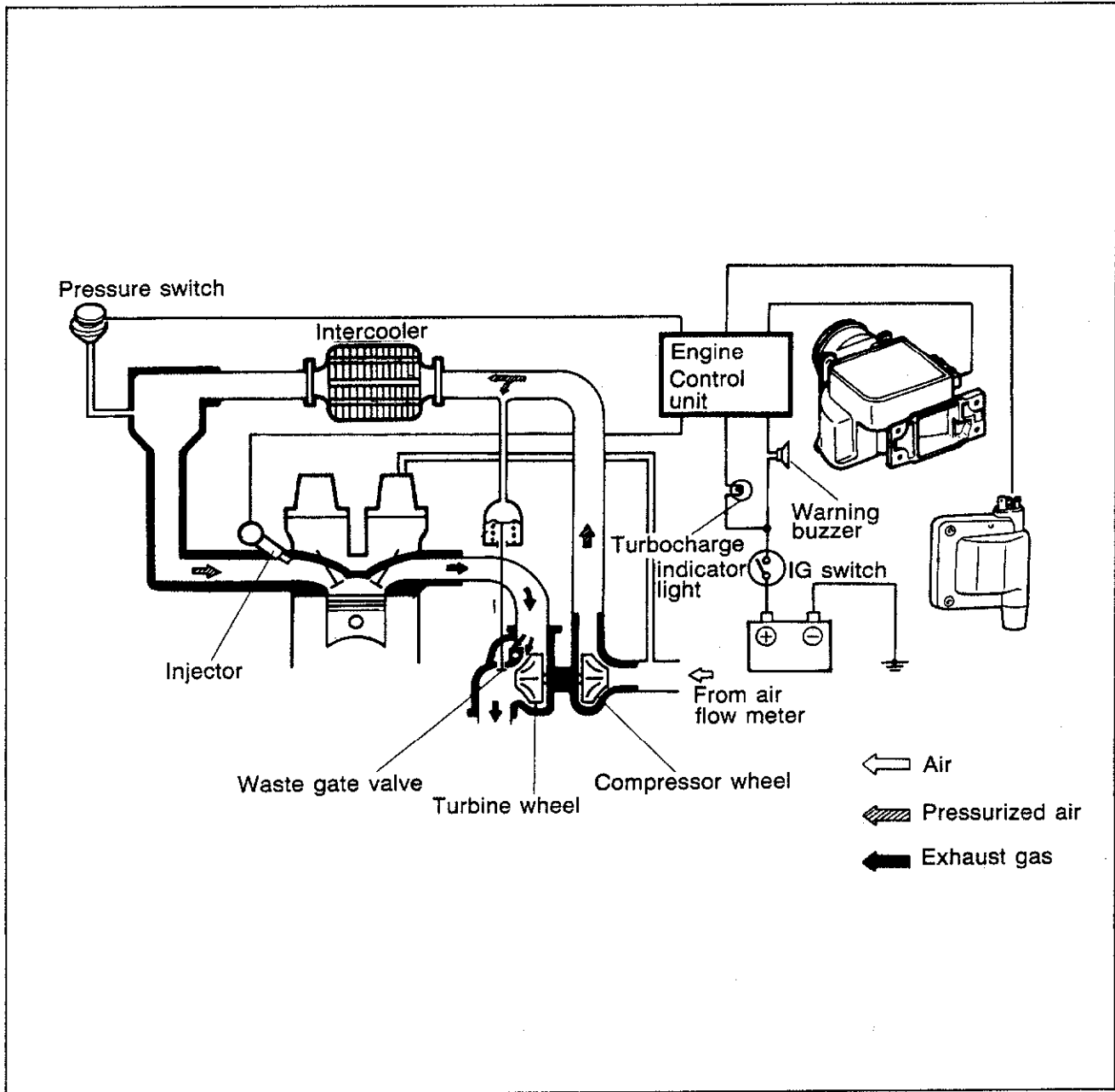

83U04B-106

The turbocharger is composed of the turbine wheel (driven by exhaust gases), compressor wheel (which pressurizes the intake air), full-floating bearings (which support the compressor and turbine wheels), seal rings (which prevent oil leakage), housing, actuator (which controls the waste-gate valve), and waste-gate valve (which opens and closes the exhaust gas bypass passage). By utilizing the flow of exhaust gases, the turbocharger, pressurizes the intake air to a maximum of 56 kPa (0.57 kg/cm<sup>2</sup>, 8.1 psi), thus increasing the amount of the intake air.



## TROUBLESHOOTING CHART

<div style="position: relative; height: 100px;"> <span style="position: absolute; top: 0; right: 0; font-size: 2em;">}</span> </div>	POSSIBLE CAUSE						Engine control unit	
	Pressure switch	Waste gate valve	Turbocharger	Knock sensor	Knock control unit	1U		
	SYMPTOM	4B-63	4B-63	4B-62	5-43	5-44	4B-76	4B-77
Poor acceleration, hesitation, and lack of power		1	2					
Knocking	2	1		3	4	5	6	
Abnormal noise			1					
Vibration			1	2	3	4	5	
White smoke			1					
Excessive oil consumption			1					

83U04B-107

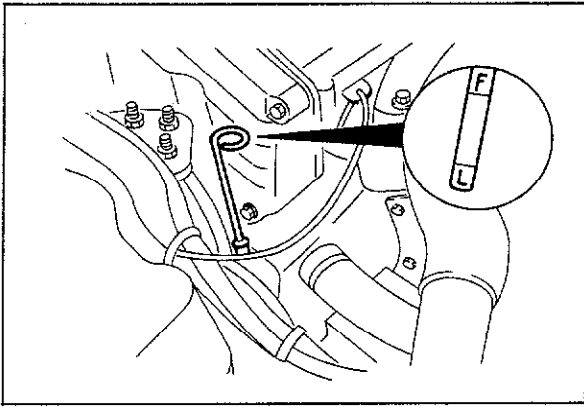

83U04B-108

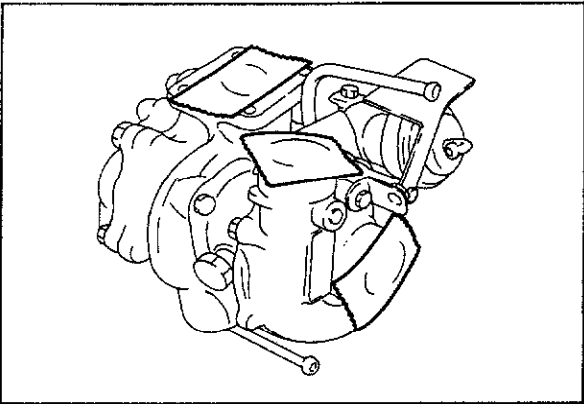

63G04C-333

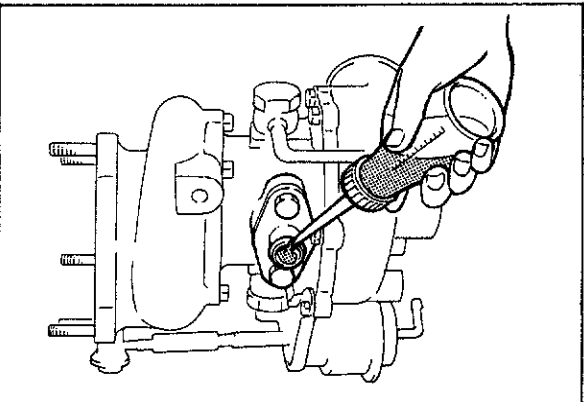

63G04C-334

## REMOVAL AND INSTALLATION

### Precaution

1. When replacing the turbocharger, always check the engine oil level and quality, as well as the oil pipe leading to the turbocharger, and the oil return pipe. If necessary, replace them.

2. Be careful of the following when removing, installing, and handling the turbocharger.

- Do not drop the turbocharger.
- Do not bend the actuator mounting or rod.
- Cover the intake, exhaust and oil passages to prevent dirt or other particles from entering.

3. When reinstalling the turbocharger, perform the following.

- Remove all the gaskets and sealant.
- Use new gaskets.
- Add **25 cc** of oil in the oil passage of the turbocharger.

4. After replacing the turbocharger, perform the following.

- Disconnect the connector from the negative terminal of the ignition coil.
- Crank the engine for **20 seconds**.
- Reconnect the negative terminal connector.
- Start the engine and run at idle for **30 seconds**.

## Removal and Installation of Turbocharger

1. Remove the turbocharger in the sequence shown in the figure.
2. Install in the reverse order of removal.

63G04C-336

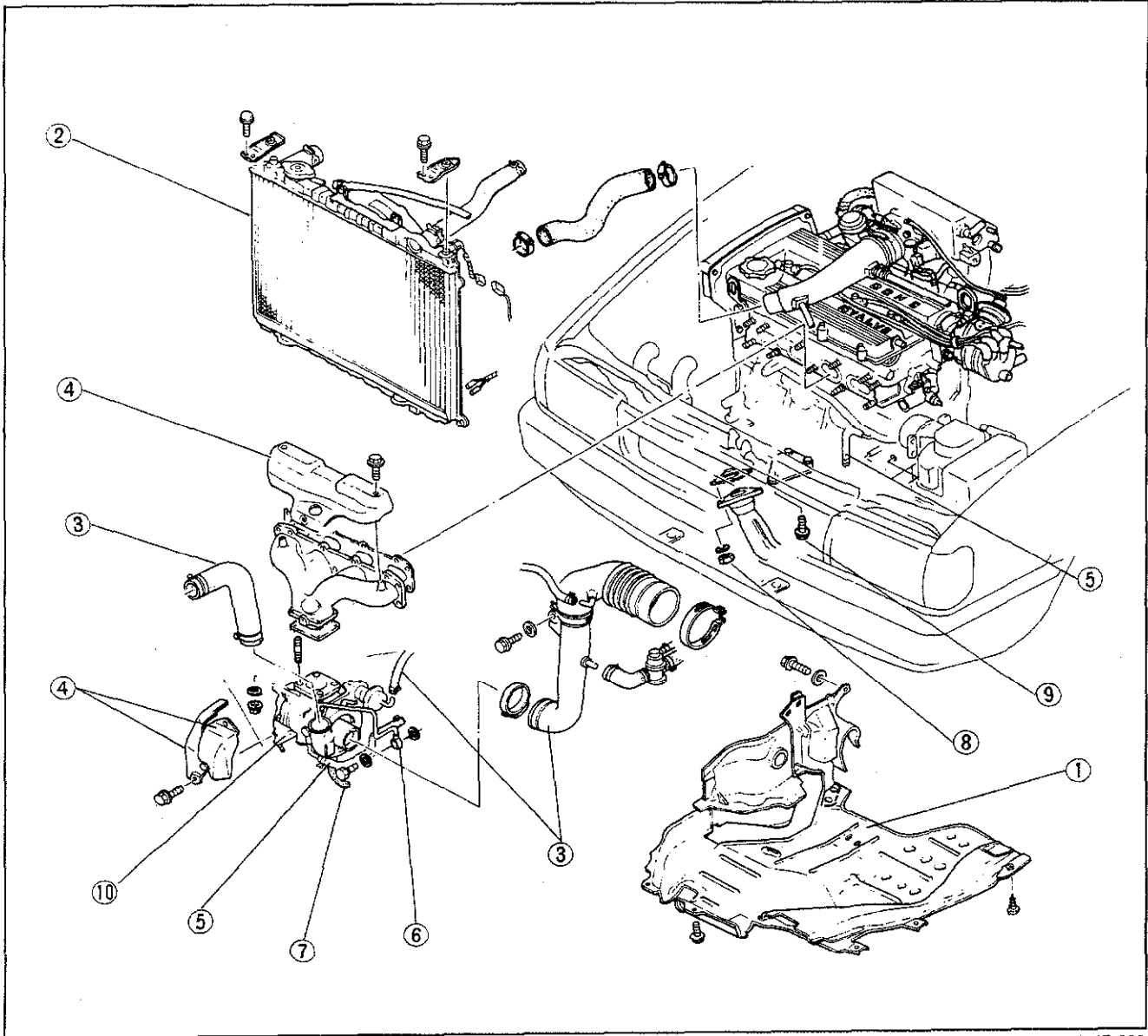

83U04B-200

- |                          |                    |
|--------------------------|--------------------|
| 1. Under cover           | 6. Oil pipe        |
| 2. Radiator              | 7. Oil return pipe |
| 3. Air pipe and air hose | 8. Attaching nuts  |
| 4. Insulator covers      | 9. Attaching bolts |
| 5. Water hoses           | 10. Turbocharger   |

### Caution

- a) Before removing the radiator, drain the engine coolant.
- b) Replace the mounting gasket if bent or cracked.
- c) Use the specified nut to mounts the turbocharger.

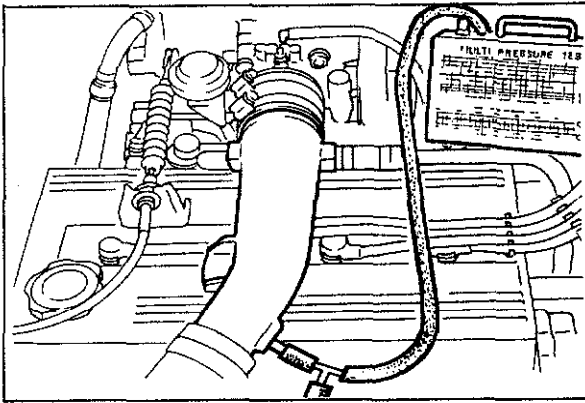

83U04B-109

## INSPECTION

### Turbocharger Boost Pressure

1. Disconnect the air hose to the waste gate valve.
2. Connect a pressure gauge as shown.
3. Connect a tachometer to the engine.
4. Warm up the engine to operating temperature.
5. Increase the engine speed to **4,000 rpm** and check that the boost pressure is within the specification.

### Specification

**Min. 2.0 kPa (0.02 kg/cm<sup>2</sup>, 0.28 psi)**

6. If not within specification, check the turbocharger.

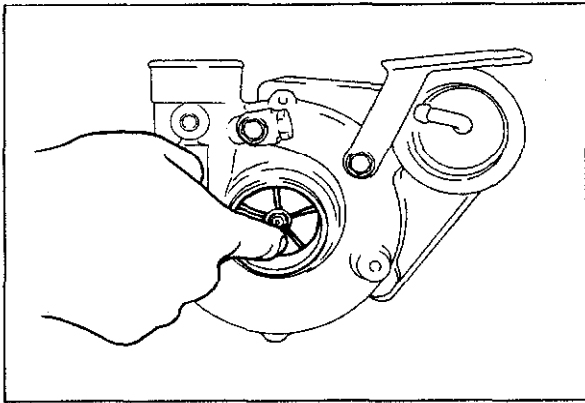

83U04B-110

### Turbocharger Inspection of wheel assembly

1. Cool the engine.
2. Remove the air hose.
3. Check that the rotor assembly turns smoothly.
4. If there is excessive load or noise, replace the turbocharger.

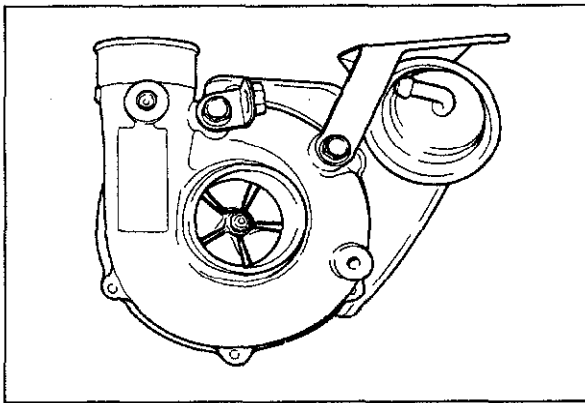

83U04B-111

### Inspection of wheel deflection

1. Cool the engine.
2. Remove the air hose.
3. Check if the wheel touches the compressor housing.
4. If the wheel touches the housing, replace the turbocharger.

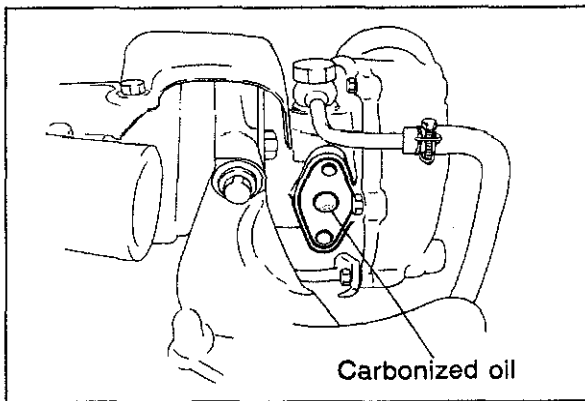

66U04B-047

### Inspection of Oil Passage

1. Cool the engine.
2. Remove the oil return pipe.
3. Check that carbonized oil has not blocked the oil passage in the turbocharger or the oil return pipe.
4. If carbonized oil blocks the oil passage, replace the turbocharger, and return pipe if necessary.

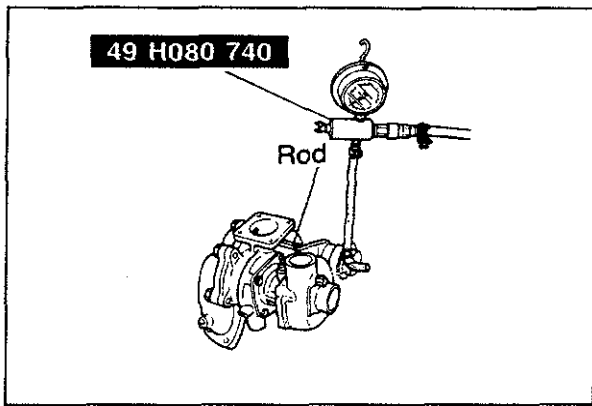

83U04B-112

### Waste Gate Valve

1. Cool the engine.
2. Remove the waste gate actuator hose and attach **SST**.
3. Adjust the compressed air pressure to **48.1—58.9 kPa (0.49—0.60 kg/cm<sup>2</sup>, 7.0—8.6 psi)**.
4. Check that the rod moves when disconnecting and reconnecting the hose applying the compressed air.

### Caution

**Do not apply compressed air higher than 98 kPa (1.0 kg/cm<sup>2</sup>, 14 psi).**

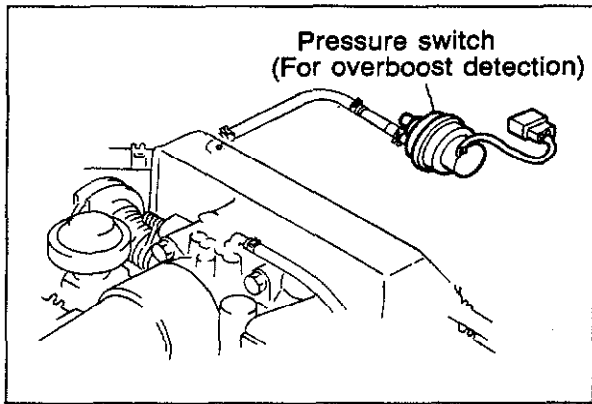

83U04B-113

### Pressure Switch

1. Turn the ignition switch ON.
2. Disconnect the hose from the pressure switch and attach **SST**.
3. Adjust the compressed air pressure to **71.8—79.8 kPa (0.73—0.81 kg/cm<sup>2</sup>, 10.4—11.6 psi)**.
4. Make sure that the warning buzzer sounds while applying the compressed air.
5. If the warning buzzer does not sound, inspect as described below.

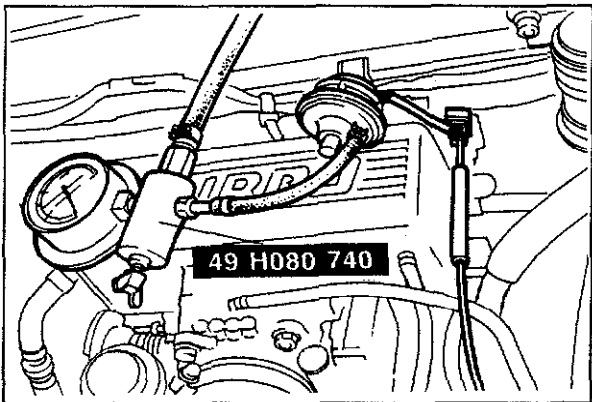

83U04B-201

### Inspection of voltage

1. Turn the ignition switch ON.
2. Apply air pressure of **71.8—79.8 kPa (0.73—0.81 kg/cm<sup>2</sup>, 10.4—11.6 psi)** to the pressure switch, then check the voltage at the (Lg) and (B) terminals with the connector connected.

Condition	Lg	B
Compressed air applied	12 V	0 V
Compressed air not applied	0 V	0 V

If the voltage is not correct, go to next step.

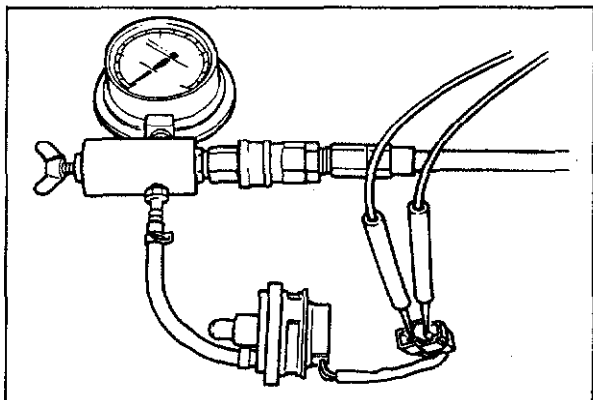

63G04C-340

### Inspection of the pressure switch

1. Turn the ignition switch OFF.
2. Disconnect the pressure switch connector.
3. Apply air pressure of **71.8—79.8 kPa (0.73—0.81 kg/cm<sup>2</sup>, 10.4—11.6 psi)** to the pressure switch, then check the continuity between the terminals.

Condition	Continuity
Compressed air applied	Yes
Compressed air not applied	No

If the continuity is not good, replace the pressure switch.

# 4B DECELERATION CONTROL SYSTEM

## DECELERATION CONTROL SYSTEM

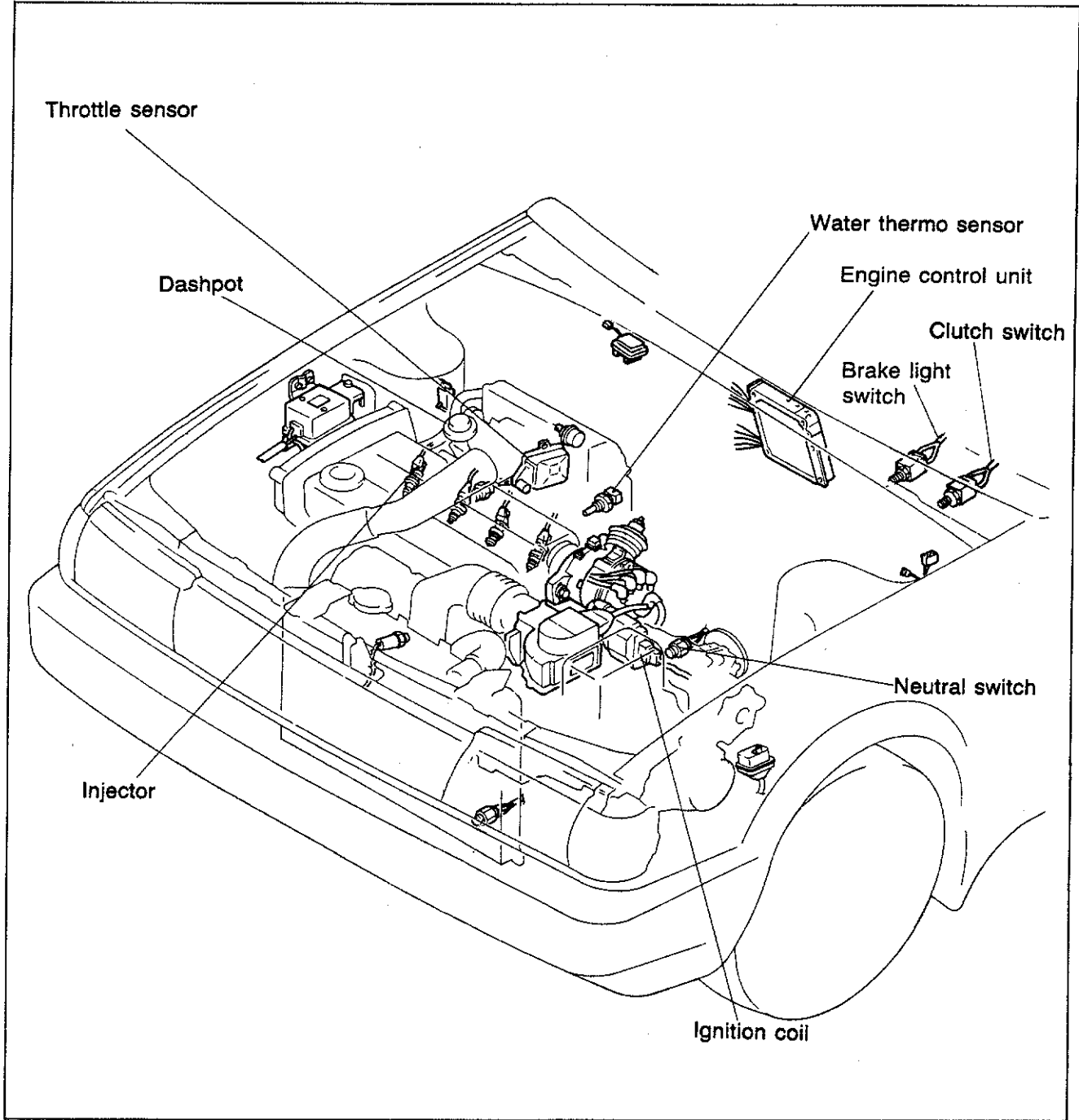

83U04B-114

The fuel cut function is provided in the deceleration control system. This function is to improve fuel consumption.

## TROUBLESHOOTING CHART

SYMPTOM	POSSIBLE CAUSE										
	Water thermo sensor	Injector	Electrical signal		Dashpot adjustment						
			3C	3E							
	4B-82	4B-47	4B-77		4B-66						
Runs rough on deceleration	3	2	1		4						
Afterburn in exhaust system	3	4	1		2						
Fail emission test	3	2	1		4						

83U04B-159

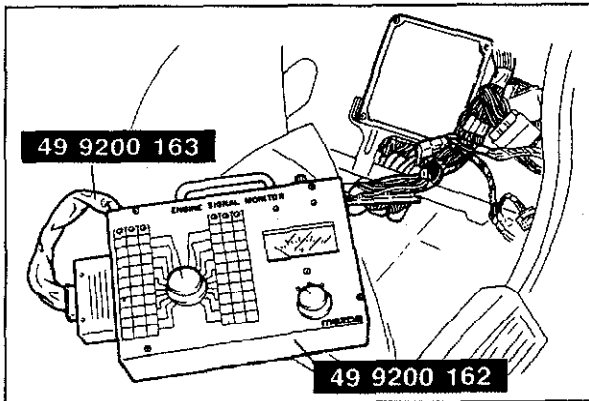

83U04B-115

### System Inspection (Electrical Signal)

1. Connect **SST** between the wiring harness and engine control unit.
2. Warm up the engine and run at idle.
3. Set "3C" and "3E" position on **SST**.

#### Note

- "3C" — For No. 2 and No. 4 injectors
- "3E" — For No. 1 and No. 3 injectors

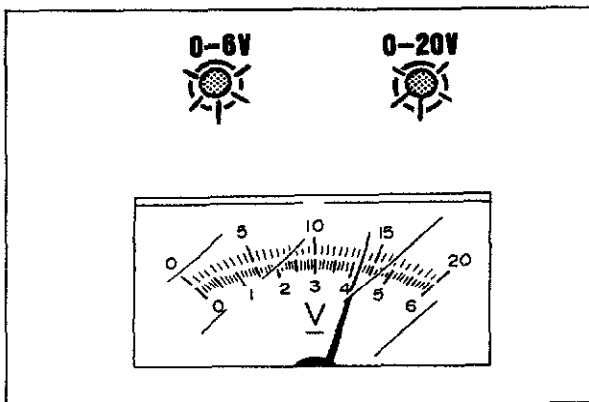

83U04B-116

4. Check that both indicator lamps flash at idle.

# 4B DECELERATION CONTROL SYSTEM

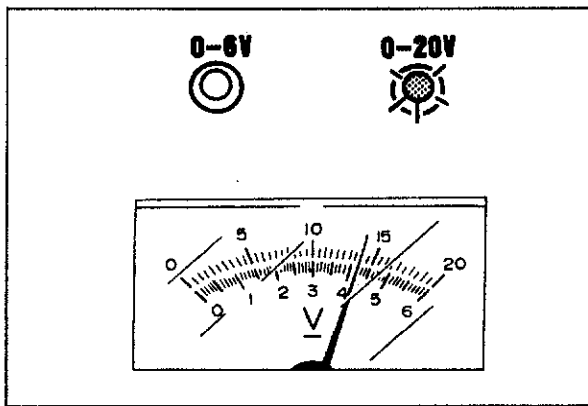

83U04B-117

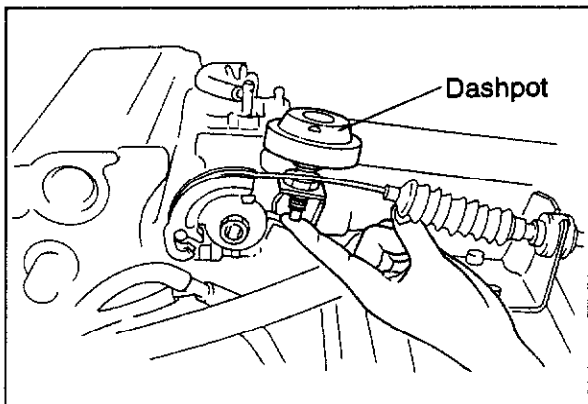

83U04B-118

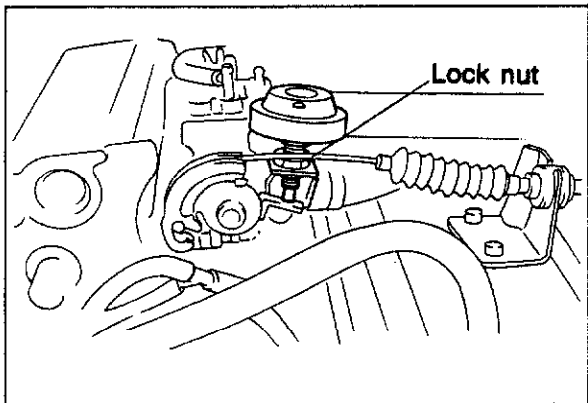

83U04B-119

5. Increase the engine speed to **4,000 rpm**, then suddenly decrease the engine speed.
6. Check that only the red indicator lamp illuminates during deceleration.

## Dashpot Inspection

1. Push the dashpot rod with a finger and make sure the rod goes into the dashpot slowly.
2. Release the finger and make sure the rod comes out quickly.

## Adjustment

1. Warm up the engine to the normal operation temperature and run it at idle speed.
2. Connect tachometer.
3. Increase the engine speed above 3,500 rpm.
4. Gradually decrease the engine speed and check the dashpot rod contact speed.

**Contact speed: 2,000 ± 150 rpm**

5. To adjust, loosen the lock nut and adjust by turning the dashpot, tighten lock nut after adjusting.



## EVAPORATIVE EMISSION CONTROL SYSTEM

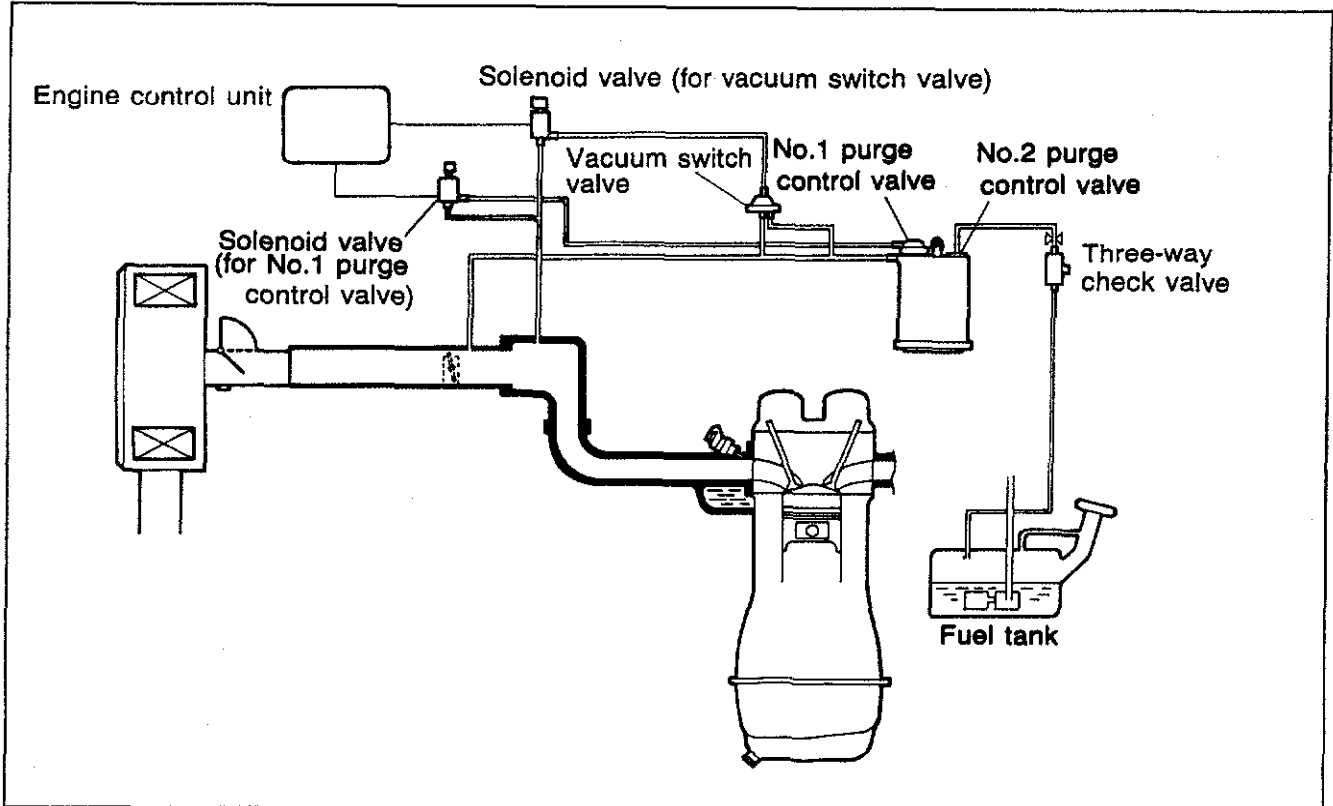

83U04B-120

The evaporative emission control system is controlled by signal from the water thermo sensor, the intake air thermo sensor, the air flow meter, and the engine speed sensor (ignition coil). The control unit determines the engine operating conditions from the signals, and control the evaporative emission control system by operating the solenoid valves for No. 1 purge control valve and vacuum switch valve when specified conditions exist.

### TROUBLESHOOTING CHART

SYMPTOM	POSSIBLE CAUSE										
	Ignition coil	Water thermo sensor	Intake air thermo sensor	Engine control unit		Solenoid valve (for No.1 purge control valve)	Solenoid valve (for vacuum switch valve)	Vacuum switch valve	No.1 purge control valve	No.2 purge control valve	Three-way check valve
				20	2P						
Page	5-30	4B-82/4B-79		4B-76		4B-69		4B-70	4B-69	4B-69	4B-70
Checking order	11	10	9	3	4	1	2	7	5	6	8

# 4B EVAPORATIVE EMISSION CONTROL SYSTEM

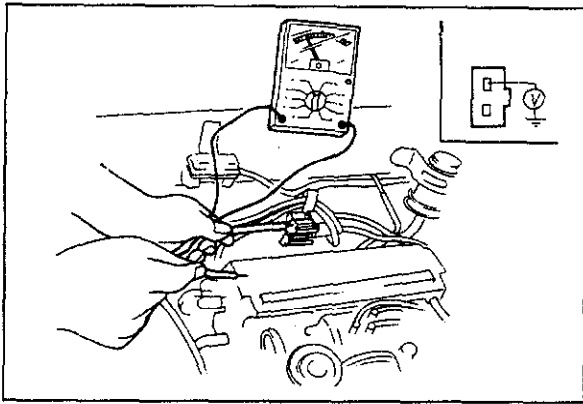

83U04B-121

## SYSTEM INSPECTION

1. Warm up the engine and run it at idle.
2. Connect a voltmeter to the solenoid valve for No. 1 purge control valve (YG) terminal

**Voltage: approx. 12V**

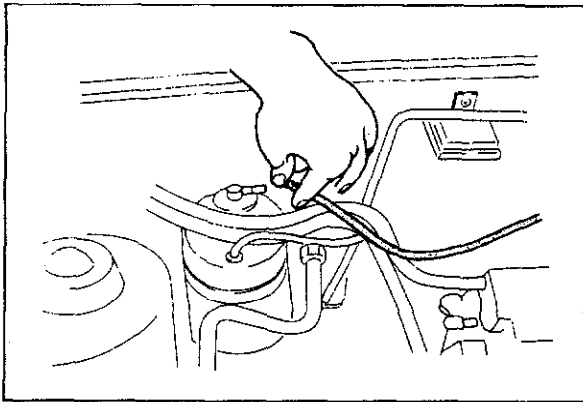

63U04B-095

3. Disconnect the vacuum hose from the No. 1 purge control valve and place a finger over the hose opening.
4. Increase the engine speed to about **2,000 rpm** and make sure air is not sucked in.

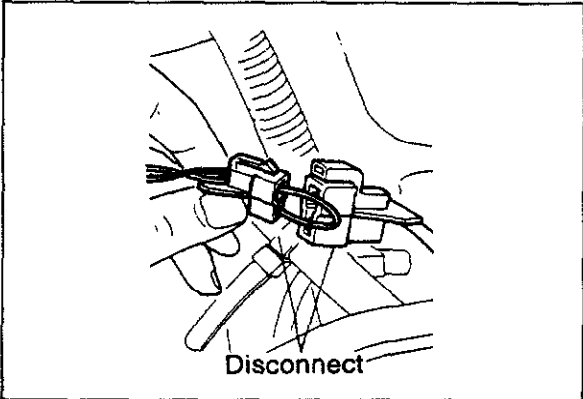

83U04B-122

5. Disconnect the neutral switch connector, and connect a jumper wire to the neutral switch connector.
6. Disconnect the throttle sensor connector (vacuum hose disconnected)
7. Check the terminal voltage (YG)

**Voltage: below 1.5V**

8. Place finger over the hose opening.
9. Increase the engine speed to about **2,000 rpm** and check that air is sucked in.
10. If not correct, check the solenoid valve for No.1 purge control valve, engine control unit 2P terminal, and No.1 purge control valve.

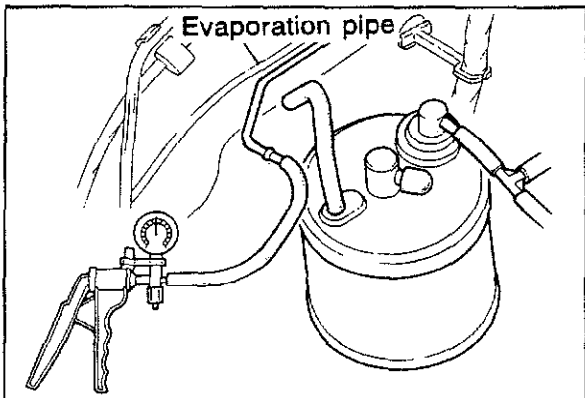

83U04B-124

11. Disconnect the evaporation hose from the evaporation pipe.
12. Connect the vacuum pump to the evaporation pipe.
13. Operate the vacuum pump and check that no vacuum is held.
14. If vacuum is held, check the three-way check valve or evaporation pipe for clog.

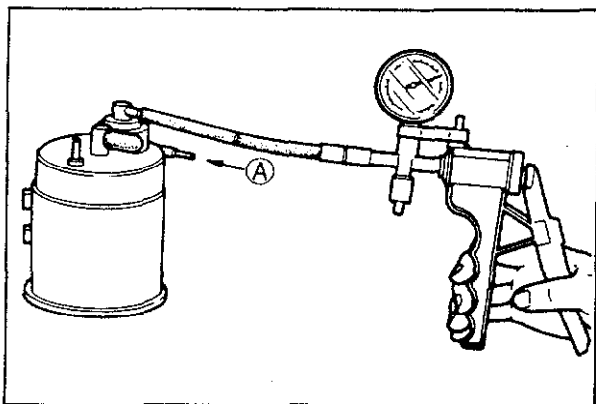

56G04A-449

## NO. 1 PURGE CONTROL VALVE

### Inspection

1. Blow through the purge control valve from port (A) and check that air does not flow.
2. Connect a vacuum pump to the purge control valve.
3. Apply **110 mmHg (4.33 inHg)** vacuum, and blow through port (A) again; air should flow from port (A).

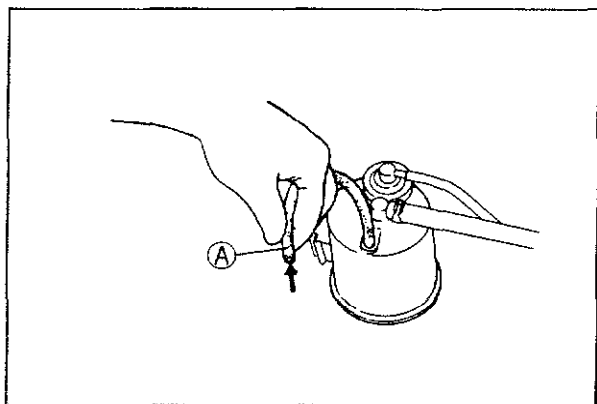

56G04A-450

## NO. 2 PURGE CONTROL VALVE

### Inspection

1. Disconnect vacuum hose (B) from the evaporation pipe.
2. Blow into the hose and check that air flows freely.

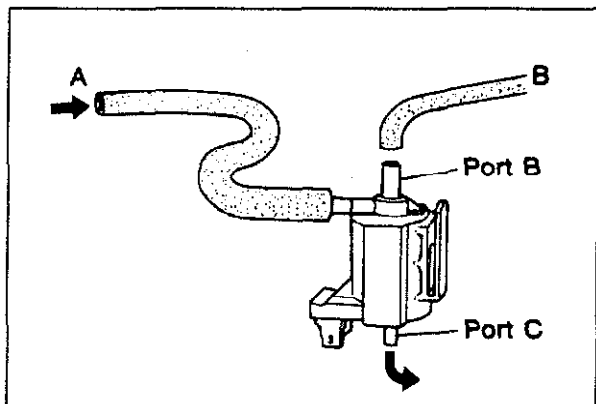

83U04B-126

## SOLENOID VALVE

1. Disconnect vacuum hose (A) from the servo diaphragm.
2. Disconnect vacuum hose (B) from the solenoid valve.
3. Disconnect the connector of the solenoid valve.
4. Blow air through the solenoid valve from hose (A) and make sure air comes out of port (C).

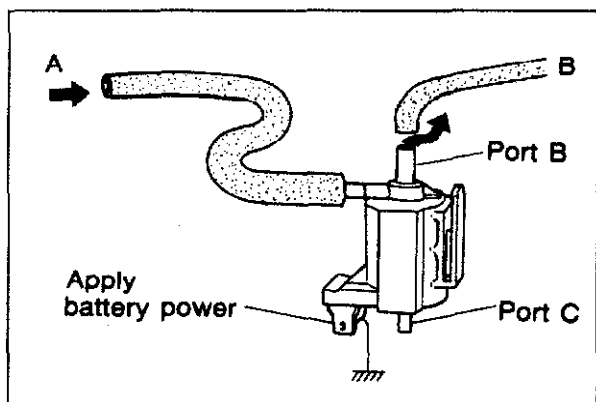

83U04B-127

5. Apply battery power to the solenoid valve with a suitable jumper wire.
6. Blow air through the solenoid valve from hose (A) and check that air comes out of port (B).
7. If the solenoid valve does not operate properly, replace it with a new one.

# 4B EVAPORATIVE EMISSION CONTROL SYSTEM

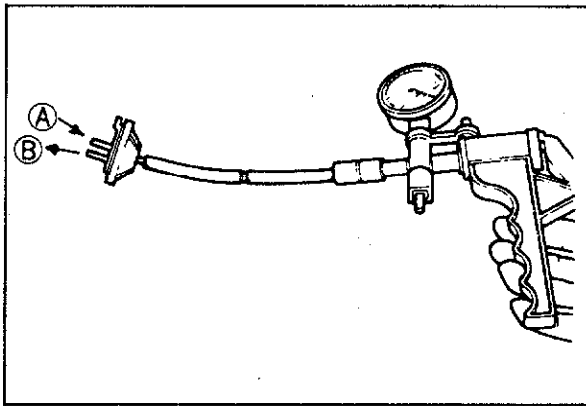

83U04B-128

## VACUUM SWITCH VALVE

1. Remove the vacuum switch valve.
2. Connect a vacuum pump to the valve.
3. Blow through the valve from port (A) and confirm that air comes out of port (B) when applied vacuum is more than the specified vacuum amount.

### Specified vacuum:

**70—100 mmHg (2.76—3.94 inHg)**

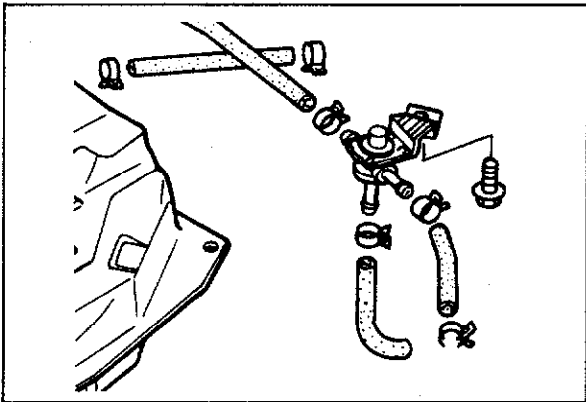

83U04B-202

## THREE-WAY CHECK VALVE

1. Remove the three-way check valve.

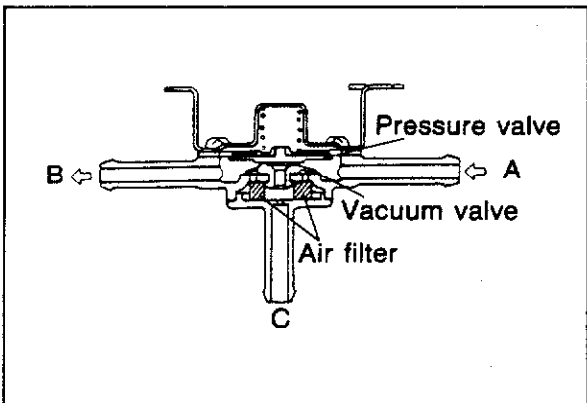

63U04B-103

2. Blow through the valve from port (A), and check that air flows out through port (B). Next, block port (B), and check that air flows out through port (C).
3. Block port (B), and suck through port (A). Check that air is pulled in through port (C).

## POSITIVE CRANKCASE VENTILATION (PCV) SYSTEM

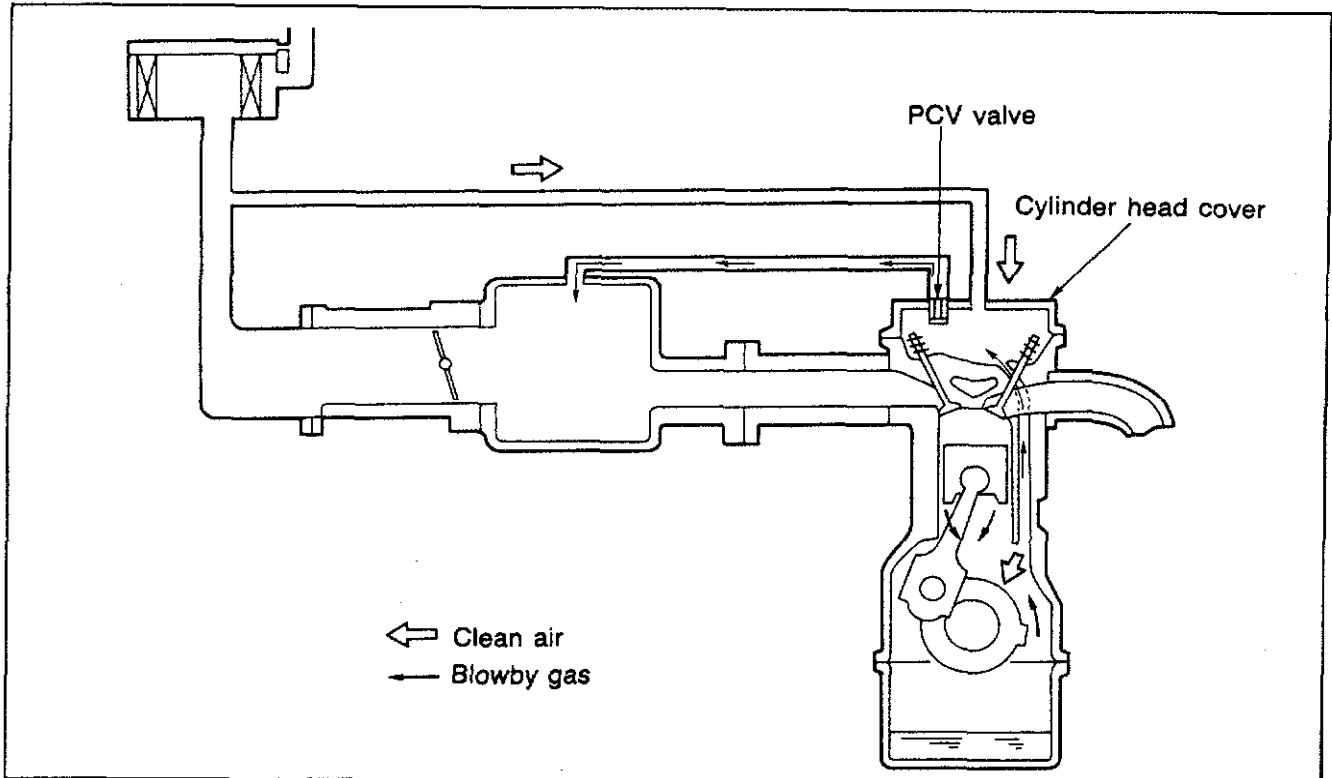

83U04B-129

The PCV valve is operated by intake manifold vacuum.

When the engine is running at idle, the PCV valve is slightly opened and small amount of blow-by gas is drawn into the dynamic chamber.

At high engine speed, the PCV valve is further opened and large amount of blow-by gas; drawn into the dynamic chamber.

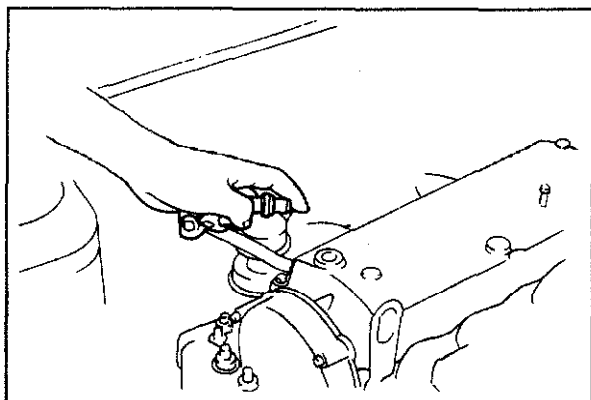

83U04B-130

### PCV VALVE

#### Inspection

1. Warm up the engine to the normal operating temperature and run it at idle speed.
2. Disconnect the PCV valve together with the ventilation hose from the cylinder head cover.
3. Close the PCV valve opening with finger. Make sure air is sucked into the PCV valve, if not replace the valve.

## CONTROL SYSTEM

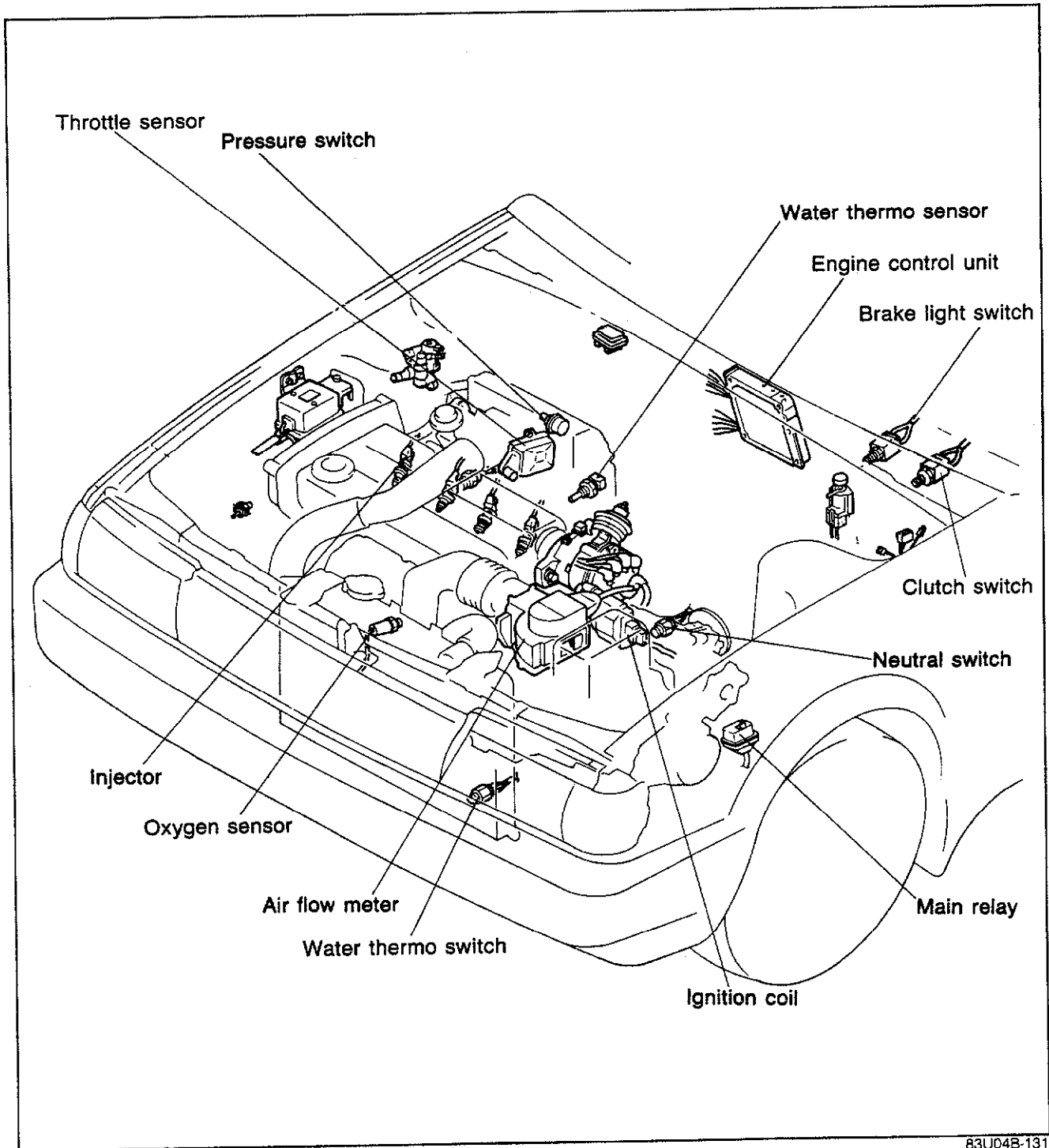

83U04B-131

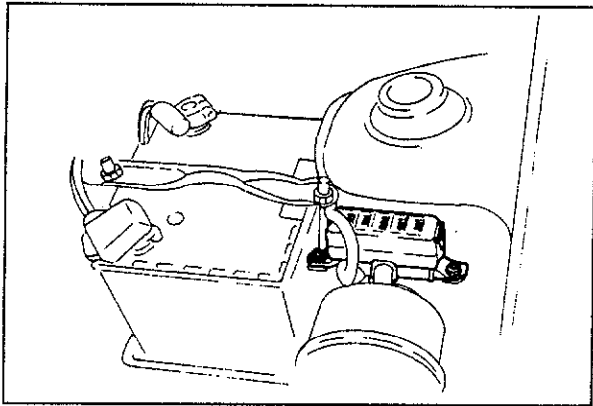

83U04B-132

## MAIN FUSE

### Inspection

Check the continuity of EGI main fuse.

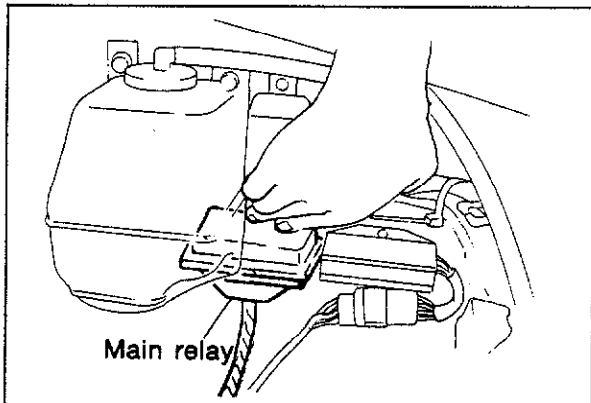

83U04B-133

## MAIN RELAY

### Inspection

1. Turn ignition switch ON and OFF, verify that the main relay "CLICKS"
2. If clicking is not heard at main relay, check the continuity at terminals using an ohmmeter, and wiring harness.

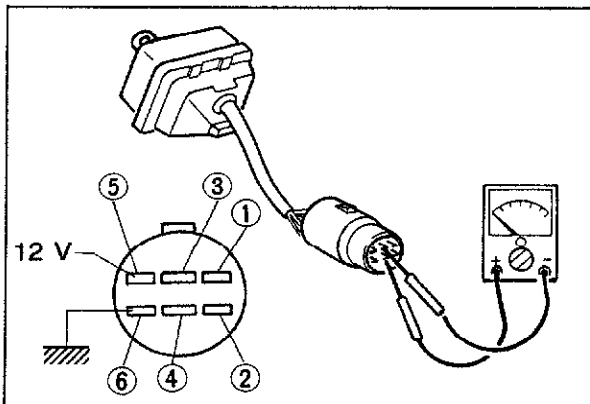

83U04B-134

## Continuity

1. Apply 12V to ⑤ and a ground ⑥ terminals of the main relay.
2. Check continuity at terminals using an ohmmeter.

Operation Terminals	12V Not applied	12V Applied
①—②	No	Yes
③—④	No	Yes

3. If not correct, replace it.

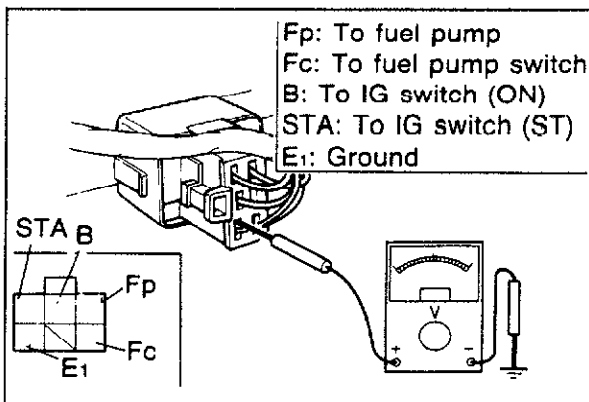

83U04B-135

## CIRCUIT OPENING RELAY

### Inspection

#### Terminal voltage

1. Check voltage between each terminal and ground using a voltmeter.

Condition	Terminal	Fp	Fc	B	STA	E1
IG SW: ON		0V	12V	12V	0V	0V
Measuring plate: open		12V	0V	12V	0V	0V
IG SW: ST		12V	0V	12V	12V	0V

2. If not correct, check the resistance using the ohmmeter.

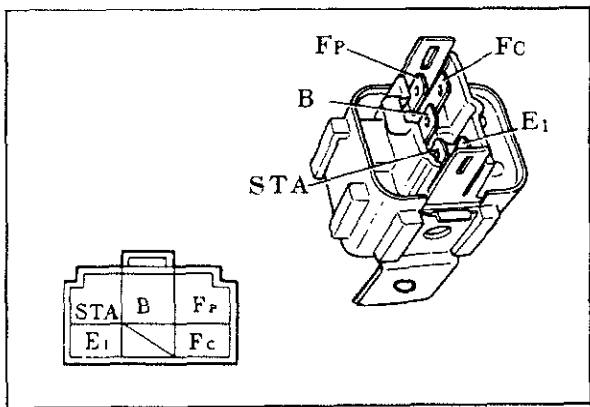

83U04B-136

## Resistance

1. Check the resistance between the terminals using an ohmmeter.

Between terminals	Resistance ( $\Omega$ )
STA ↔ E1	15—30
B ↔ Fc	80—150
B ↔ Fp	$\infty$

2. If not correct, replace the relay.

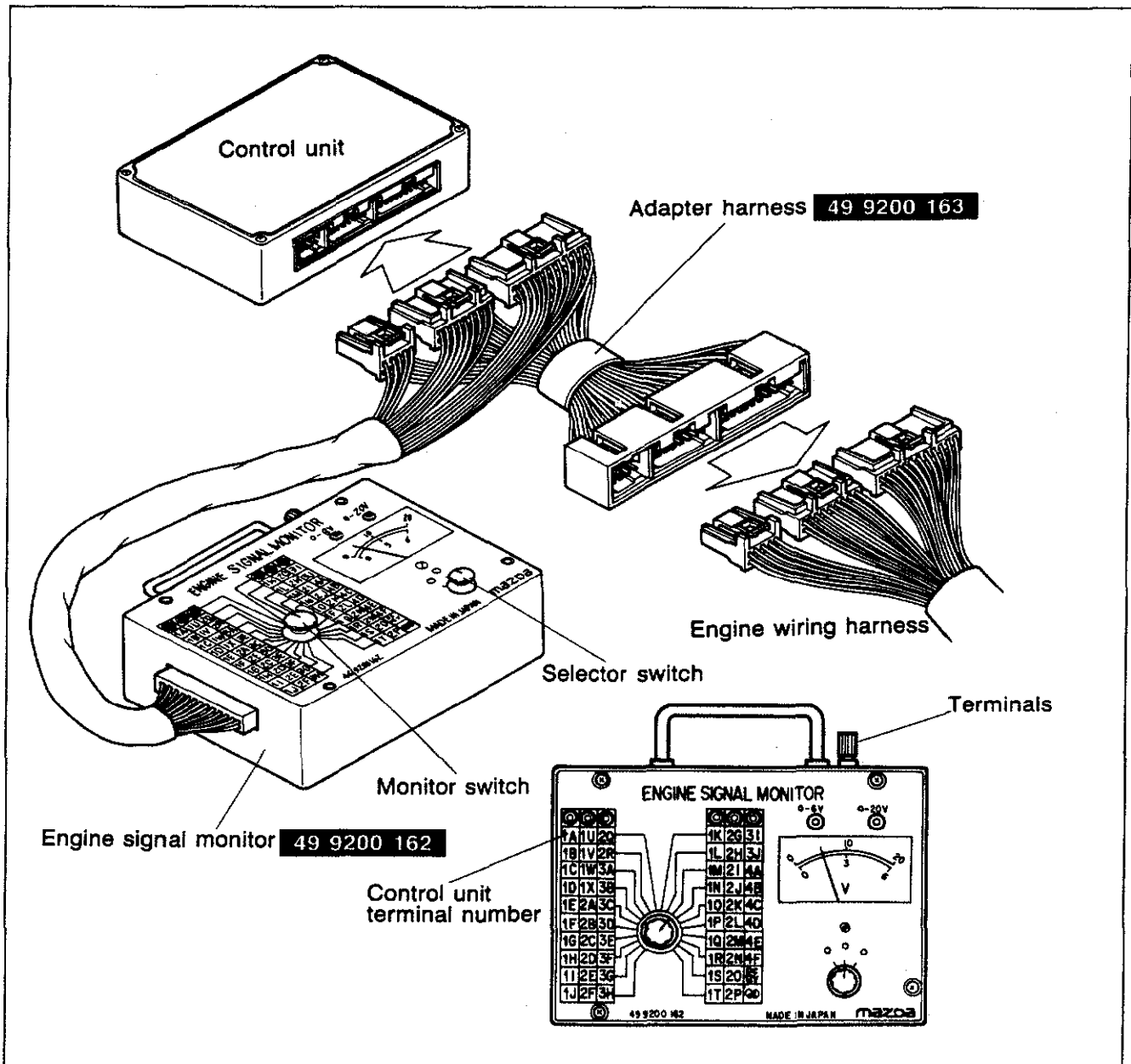

**ENGINE CONTROL UNIT****Engine Signal Monitor (49 9200 162) and Adapter (49 9200 163)**

83U04B-137

The Engine Signal Monitor (49 9200 162) was developed to check the engine control unit terminal voltages. This monitor easily inspects the terminal voltage by setting the monitor switch.

**How to Use the Engine Signal Monitor**

1. Connect the **Engine Signal Monitor** (49 9200 162) between the engine control unit and the engine harness using the **adapter** (49 9200 163).
2. Turn the selector switch and monitor switch to select the terminal number.
3. Check the terminal voltage.

**Do not apply voltage to terminals.**

# 4B CONTROL SYSTEM

Terminal	Connected to	Voltage	Condition	Remark
1A (Output)	MIL	Below 2.5V	Ignition switch OFF → ON for 3 sec.	Test connector grounded
		Approx. 12V	After 3 sec.	
1B (Output)	Self-Diagnosis Checker (for Code No.)	Below 2.5V	Ignition switch OFF → ON for 3 sec.	Test connector grounded Checker connected
		Approx. 12V	After 3 sec.	
1C	—	—	—	—
1D (Output)	Self-Diagnosis Checker (for Monitor lamp)	Approx. 5V	Ignition switch OFF → ON for 3 sec.	Test connector grounded Checker connected
		Approx. 12V	After 3 sec.	
1E (Input)	Throttle sensor (IDL switch)	Approx. 12V	Accelerator pedal depressed	
		Below 1.5V	Accelerator pedal released	
1F (Output)	A/C control relay	Approx. 12V	Ignition switch ON	
		Below 1.5V	A/C switch ON (at idle)	
1G (Input)	Neutral/clutch switch	Approx. 12V	Clutch pedal depressed	In-gear condition (Neutral: Constant 12V)
		Below 1.5V	Clutch pedal released	
1H (Input)	Water thermo switch (Radiator)	Approx. 12V	Below 17°C (63°F)	
		Below 1.5V	Above 17°C (63°F)	
1I (Input)	Electrical load (E/L) switch	Approx. 2.5V	E/L switch ON	
		Approx. 12V	E/L switch OFF	
1J (Input)	Brake light switch	Approx. 12V	Brake pedal depressed	
		Below 1.5V	Brake pedal released	
1K (Input)	Power steering switch	Approx. 12V	Power steering switch OFF	
		Below 1.5V	Power steering switch ON	
1L (Input)	A/C switch	Approx. 12V	A/C switch OFF	Blower motor ON
		Below 2.5V	A/C switch ON	
1M (Input)	Ignition coil	Approx. 12V	Ignition switch ON	(When engine running) Engine Signal Monitor: Green and red light flash
		Approx. 12V	At idle	
1N	G sensor (Distributor)	Below 1.5V	Ignition switch ON	
		Approx. 3V	At idle	
1O	—	—	—	—
1P	—	—	—	—
1Q	—	—	—	—
1R	—	—	—	—
1S	—	—	—	—
1T	—	—	—	—
1U (Output)	Knock control unit (1 terminal)	Below 1.5V	Ignition switch ON	
		Approx. 12V	At idle	
1V (Input)	FF switch	Below 1.5V	4x4	
		Approx. 12V	FF	
1W (Input)	Test connector	Below 1.5V	Test connector grounded	
		Approx. 12V	Test connector not grounded	
1X	—	—	—	—
2A (Output)	Vref	4.5—5.5V	—	—
2B (Input)	Air flow meter (Vc)	7—9V	—	—
2C	Ground (E2)	Below 1.5V	—	—
2D (Input)	Oxygen sensor	0.3—0.7V	At idle	
		More than 0.45V	During acceleration	
		Less than 0.45V	During deceleration	

Terminal	Connected to	Voltage	Condition	Remark
2E (Input)	Air flow meter (Vs)	Approx. 2V	Ignition switch ON	
		4—5V	At idle	
2F	—	—	—	—
2G (Input)	Throttle sensor	Approx. 0.5V	Accelerator pedal released	
		Approx. 4V	Accelerator pedal depressed	
2H (Input)	Atmospheric pressure sensor	Approx. 4V	—	At sea level
2I (Input)	Water thermo sensor	Approx. 0.5V	Normal operating temperature	
2J (Input)	Intake air thermo sensor (Air flow meter)	2—3V	Intake air temperature: 20°C (68°F)	
2K (Output)	Pressure regulator control valve (PRCV) solenoid	Below 2.5V	Intake air temp. more than 58°C (136°F) Water temp. more than 90°C (194°F)	
		Approx. 12V	Other	
2L (Output)	Pressure switch	Approx. 12V	At idle	Air pressure 71.8—79.8 kPa (0.73—0.81 kg/cm <sup>2</sup> , 10.4—11.6 psi)
		Below 1.5V	At overboost	
2M (Output)	Knock control unit (f terminal)	Below 1.5V	At idle	Coolant temp: More than 80°C (176°F) Intake air temp: More than 0°C (32°F)
		Approx. 12V	Engine speed 1,000 rpm (Positive pressure)	
2N (Output)	Indicator light	Approx. 12V	At idle	71.8—79.8 kPa (0.73—0.81 kg/cm <sup>2</sup> , 10.4—11.6 psi)
		Below 1.5V	At overboost	
2O	No.2 purge control solenoid	Approx. 12V	Less than 1,500 rpm	
		Below 1.5V	More than 1,500 rpm	
2P	No.1 purge control valve solenoid	Below 1.5V	Intake air temp. more than 50°C (122°F) Water temp. more than 50°C (122°F)	In-gear condition. Jumper wire connect to the Neutral switch
		Approx. 12V	Other	
2Q	Idle speed control (ISC) valve	1.5—11.6V	At idle	Engine Signal Monitor: Green and red light flash
2R	Ground	Below 1.5V	—	—
3A	Ground	Below 1.5V	—	—
3B	Starter switch	Below 2.5V	Ignition switch ON	
		7—9V	While cranking	
3C	Injector No.2, No.4	Approx. 12V	At idle	Engine Signal Monitor: Green and red light flash
3D	—	—	—	—
3E	Injector No.1, No.3	Approx. 12V	At idle	Engine signal Monitor: Green and red light flash
3F	—	—	—	—
3G	Ground	Below 1.5V	—	—
3H	—	—	—	—
3I	Main relay	Approx. 12V	Ignition switch ON	
3J	Battery	Approx. 12V	—	—

### Engine control unit connector

3I	3G	3E	3C	3A	2Q	2O	2M	2K	2I	2G	2E	2C	2A	1W	1U	1S	1Q	1O	1M	1K	1I	1G	1E	1C	1A
3J	3H	3F	3D	3B	2R	2P	2N	2L	2J	2H	2F	2D	2B	1X	1V	1T	1R	1P	1N	1L	1J	1H	1F	1D	1B

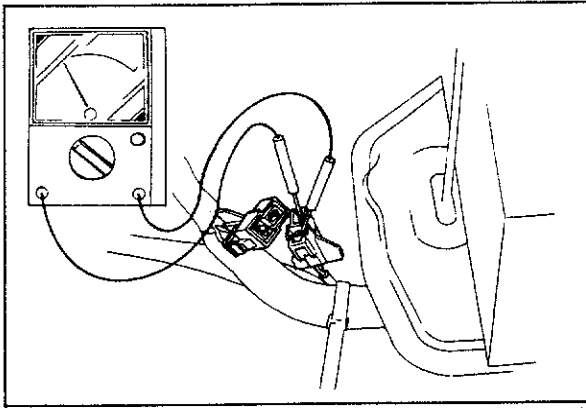

83U04B-139

## NEUTRAL SWITCH

### Inspection

1. Disconnect the neutral switch connector.
2. Connect a to the neutral switch and check the continuity through the switch.

Condition	Continuity
In neutral	No
In other ranges	Yes

3. After checking, connect the switch connector.

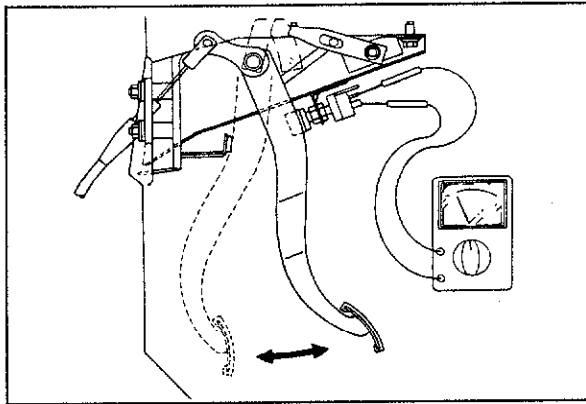

83U04B-140

## CLUTCH SWITCH

### Inspection

1. Disconnect the clutch switch connector.
2. Connect the circuit tester to the clutch switch and check the continuity between the switch terminals.

Condition	Continuity
When the pedal is depressed	No
When the pedal is released	Yes

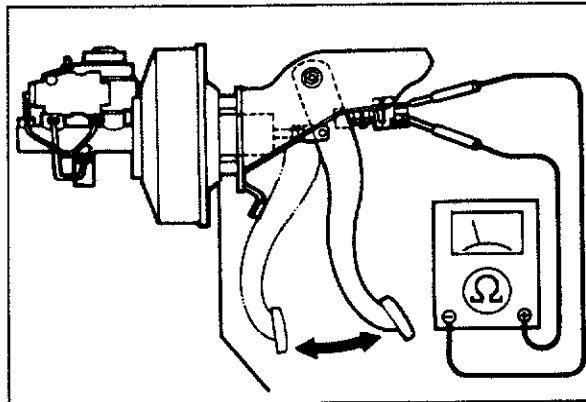

83U04B-203

## BRAKE LIGHT SWITCH

### Inspection

1. Disconnect the brake switch connector.
2. Connect an ohmmeter to the switch.
3. Check the continuity of the switch.

Pedal	Continuity
Depressed	Yes
Released	No

4. After checking, connect the switch connector.

### Note

Refer to section 11 for replacement of the brake switch.

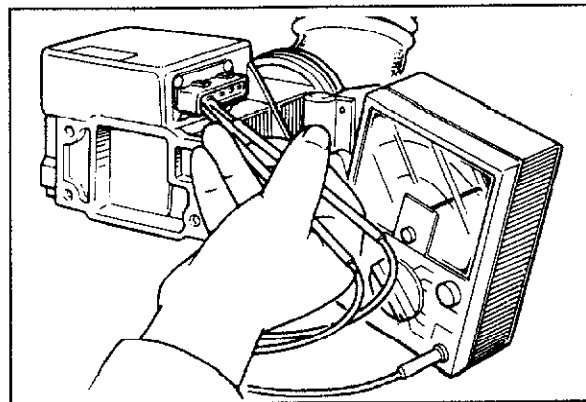

83U04B-141

## AIR FLOW METER

### Inspection

1. Inspect the air flow meter body for cracks.
2. Check the resistance between terminals using an ohmmeter.

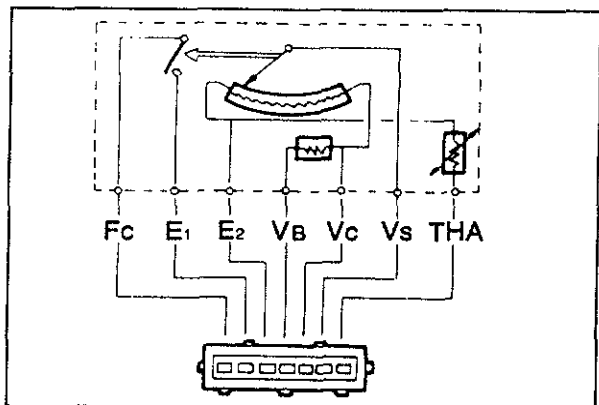

83U04B-142

Terminal	Resistance ( $\Omega$ )
E2 $\leftrightarrow$ Vs	20 to 400
E2 $\leftrightarrow$ Vc	100 to 300
E2 $\leftrightarrow$ Va	200 to 400
E2 $\leftrightarrow$ THA (Air thermo sensor)	-20°C (-4°F) 10,000 to 20,000 0°C (32°F) 4,000 to 7,000 20°C (68°F) 2,000 to 3,000 40°C (104°F) 900 to 1,300 60°C (140°F) 400 to 700
E1 $\leftrightarrow$ Fc	$\infty$

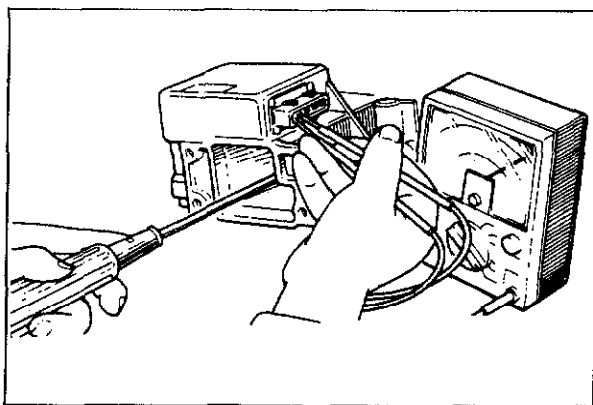

73U04B-011

3. Press open the measuring plate with a screwdriver, measure the resistance between E1 and FC (fuel pump switch) and between E2 and VS.

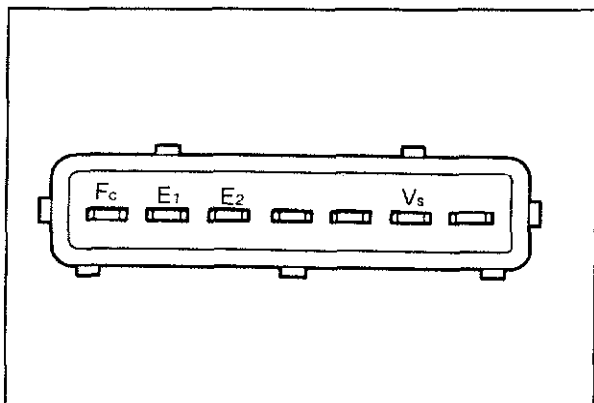

83U04B-143

Terminals	Measuring Plate	
	Fully closed	Fully open
E1 $\leftrightarrow$ Fc	$\infty$	0
E2 $\leftrightarrow$ Vs	20 to 400 $\Omega$	20 to 1,000 $\Omega$

4. If not correct replace it.

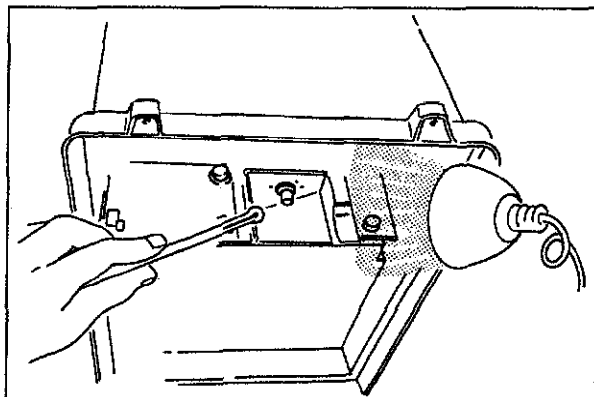

83U04B-144

## INTAKE AIR THERHO SENSOR

### Inspection of Resistance

1. Remove the air cleaner upper cover assembly.
2. Heat the intake air thermo sensor and observe the temperature.

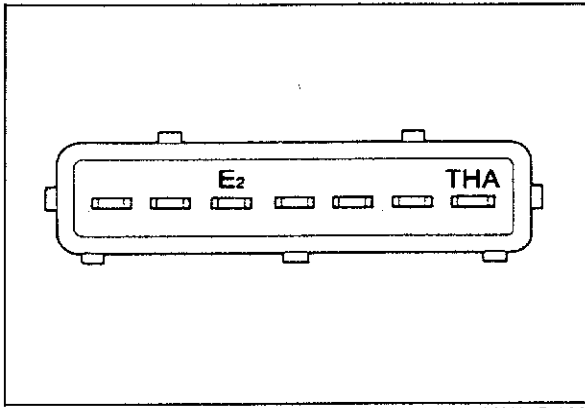

83U04B-160

3. Check resistance between the THA and E2 terminals using an ohmmeter.

Intake Air Temperature	Resistance ( $\Omega$ )
-20°C (-4°F)	10,000—20,000
20°C (68°F)	2,000—3,000
60°C (140°F)	400—700

4. If the resistance is not within specification, replace the air flow meter assembly.
5. If the resistance is within specification, check the wiring harnesses.

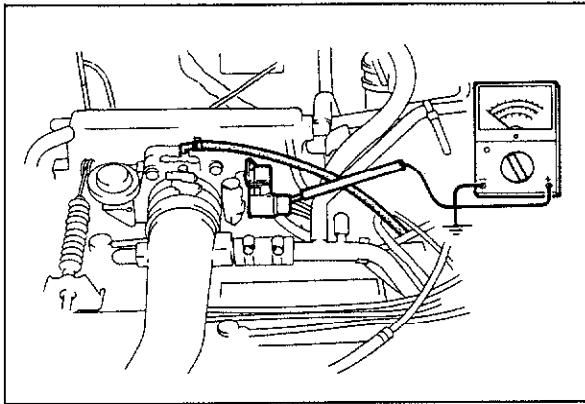

83U04B-145

### THROTTLE SENSOR Inspection of Terminal Voltage

1. Remove the rubber boot from the connector.
2. Turn the ignition switch ON.
3. Check the voltage between each terminal and ground.
4. Open the throttle valve and check the voltage between each terminal and ground.

Terminal	Condition	
	Closed	Fully opened
A (OUTPUT)	0.3—0.7V	Approx. 4.0V
B (GND)	below 1.5V	
C (Vref)	4.5—5.5V	
D (IDL)	below 1.5V	Approx. 12V

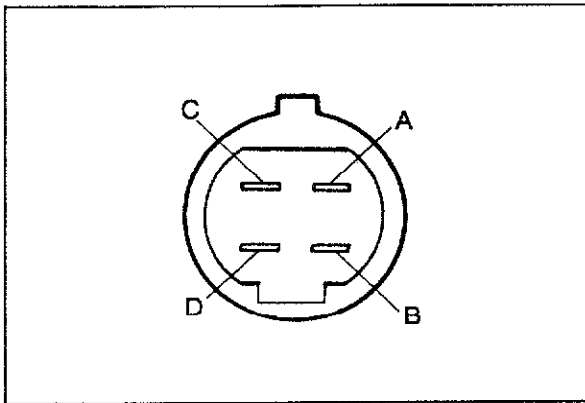

83U04B-146

5. If not correct on (D) terminal only, check the throttle sensor setting.
6. If not correct at others, check resistances of the throttle sensor and voltage of the (2A), (2C), (2E) and (1G) terminals at the Engine control unit (refer to page 4B—76).
7. Install the rubber boot to the connector.

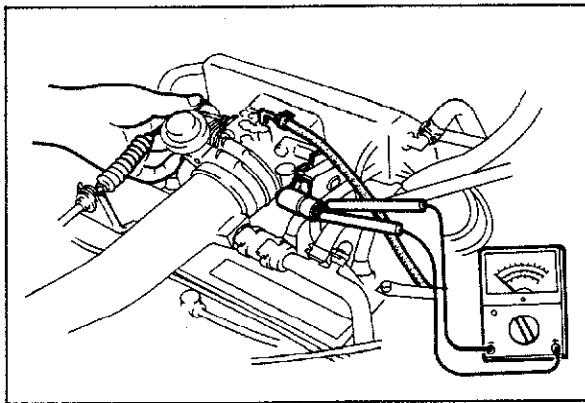

83U04B-147

### Inspection of Resistance

1. Disconnect the connector from the throttle sensor.
2. Check resistance between the terminals as shown in the table.
3. Open the throttle valve fully and check resistances between the terminals

Terminal	Condition	
	Closed	Fully opened
A — B	Approx. 500 $\Omega$	Approx. 4.5k $\Omega$
B — C	3—7 k $\Omega$	

4. If not correct, replace the throttle sensor.

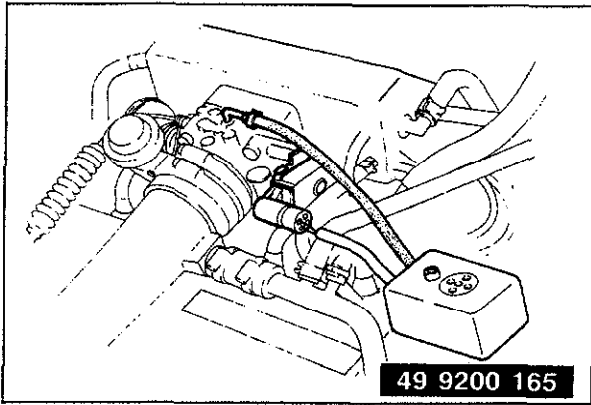

83U04B-148

### Inspection of Throttle Sensor Setting

1. Disconnect the connector from the throttle sensor.
2. Connect the **SST** or ohmmeter to the throttle sensor.

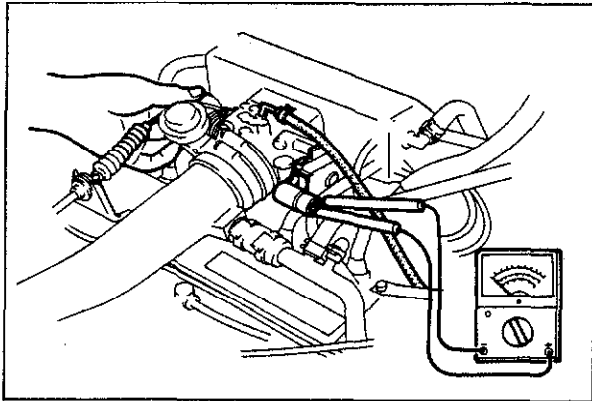

63G04C-411

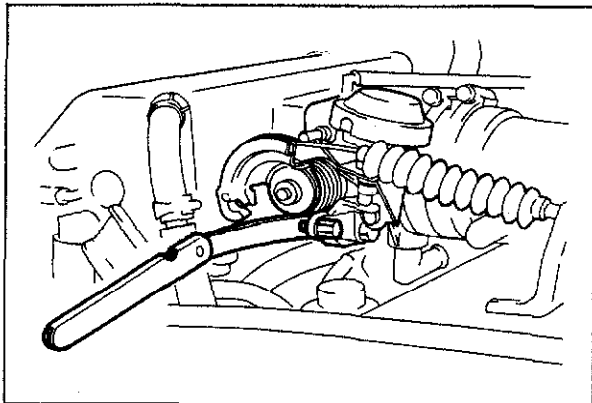

63G04C-412

3. Insert a thickness gauge between the throttle stop screw and stop lever.
4. Note the operation of the buzzer or continuity between terminals.

Thickness gauge	Buzzing of the tester	Continuity between terminals
		B — D
0.5mm (0.020 in)	Yes	Yes
0.7mm (0.027 in)	No	No

If necessary, adjust the throttle sensor

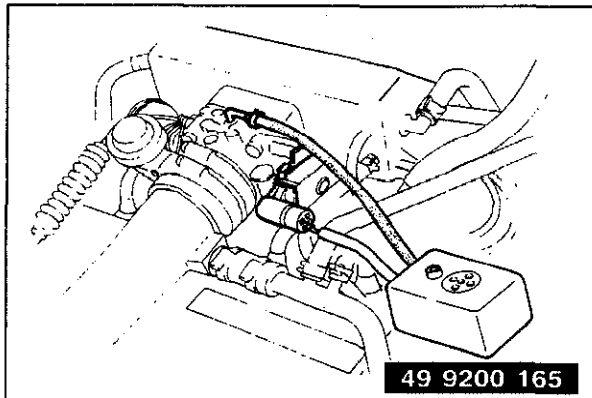

83U04B-149

### Adjustment of Throttle Sensor Setting

1. Disconnect the connector from the throttle sensor.
2. Connect the **SST** to the throttle sensor.
3. Insert a **0.5mm (0.020 in)** thickness gauge between the throttle stop screw and stop lever.

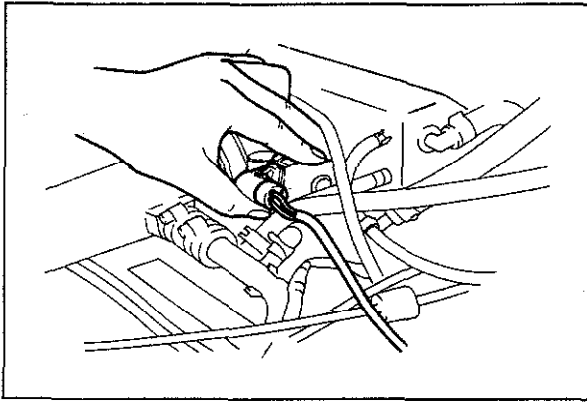

83U04B-150

4. Loosen the two attaching screws.
5. Rotate the throttle sensor clockwise about **30 degrees**, then rotate it back counterclockwise until the buzzer sounds.
6. Replace the thickness gauge with a **0.7mm (0.027 in) gauge**.
7. Check that the buzzer does not sound, or exist continuity.
8. If it sounds or continuity, repeat step 4 to 8.

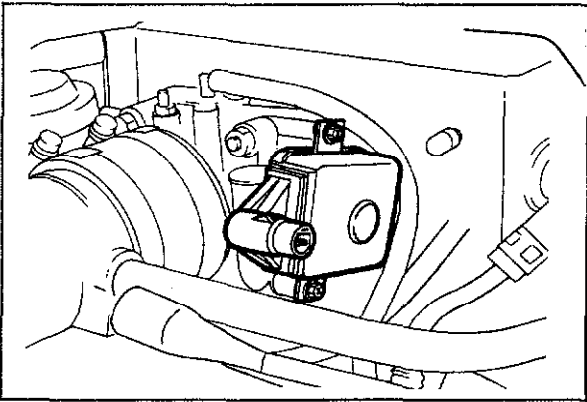

63G04C-418

9. Tighten the two attaching screws.

**Note:**

**Be careful not to move the throttle sensor from the set position when tightening the screws.**

10. Open the throttle valve fully a few times, then check the adjustment of the throttle sensor again (Refer to inspection procedures).

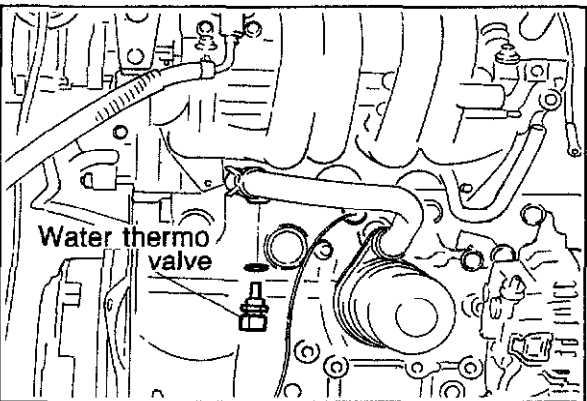

83U04B-151

**WATER THERMO SENSOR**

**Inspection of Resistance**

1. Remove the water thermo sensor.

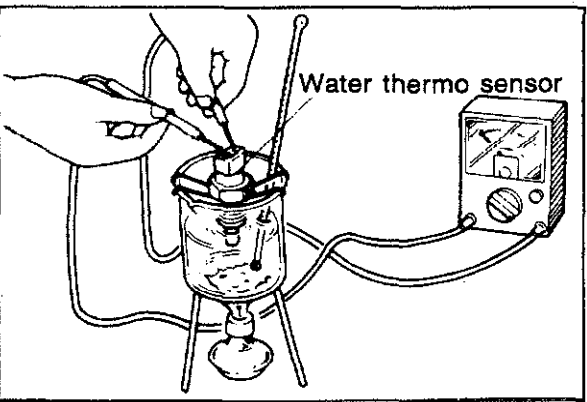

56G04B-100

2. Place the sensor in water with a thermometer and heat the water gradually.
3. Check that resistance of the sensor is within specification:

Water temperature	Resistance
-20°C (-4°F)	14.6—17.8 kΩ
20°C (68°F)	2.21—2.69 kΩ
80°C (176°F)	0.290—0.354 kΩ

4. If not correct, replace the water thermo sensor.



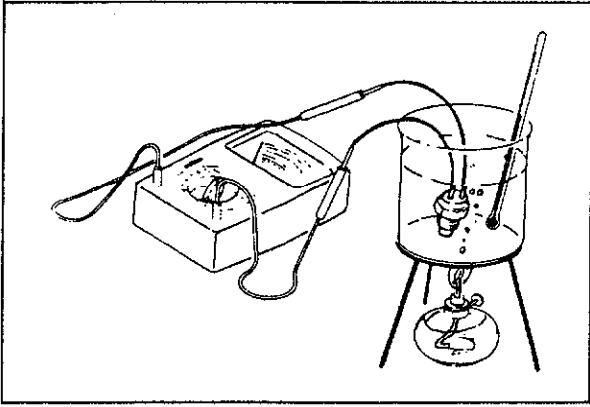

83U04B-152

**WATER THERMO SWITCH****Inspection**

1. Remove the switch from the radiator.
2. Place the switch in water with a thermometer and heat the water gradually.
3. Check that the continuity between the terminals exists at more than specification.

**Specification: 15—19°C (59—66°F)**

4. If not correct, replace the water thermo switch.

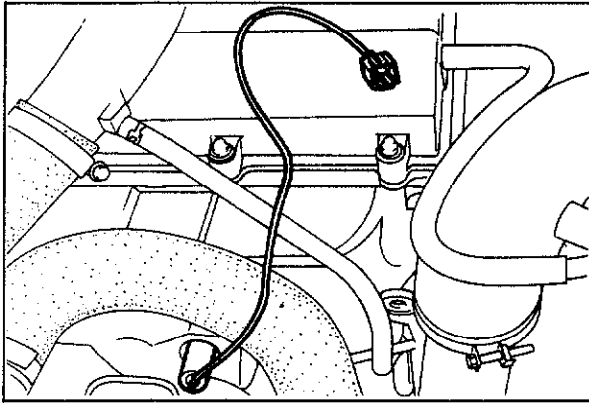

83U04B-153

**OXYGEN SENSOR**

1. Warm up the engine and run it at idle.
2. Disconnect the oxygen sensor wiring harness connector.

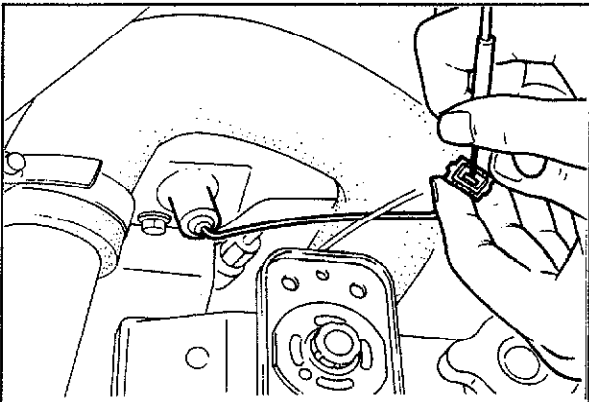

83U04B-161

3. Attach a voltmeter between the oxygen sensor connector (oxygen sensor side) and ground.
4. Run the engine speed at 4,000 rpm until the voltmeter indicates about **0.7 V**.

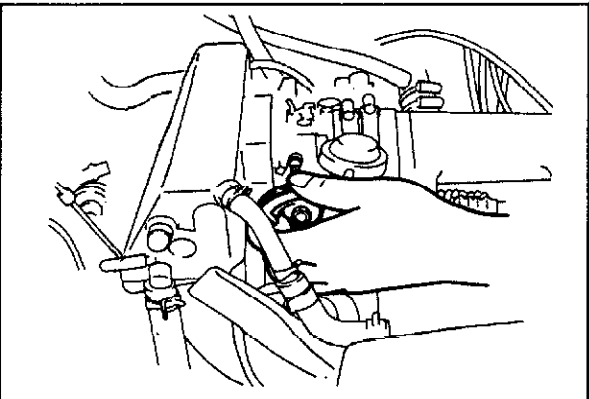

83U04B-162

5. Increase and decrease the engine speed quickly several times. When the speed is increased the meter should read between **0.5V—1.0V**. When the speed is decreased it should read between **0V—0.3V**.
6. If the voltmeter doesn't indicate above mentioned values, replace the O<sub>2</sub> sensor.

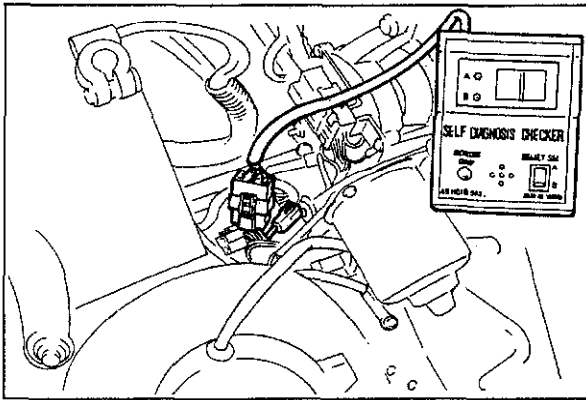

86U04A-207

### Inspection of Sensitivity

1. Warm up the engine to the normal operating temperature and run it at idle.
2. Connect the **SST** to the check connector.

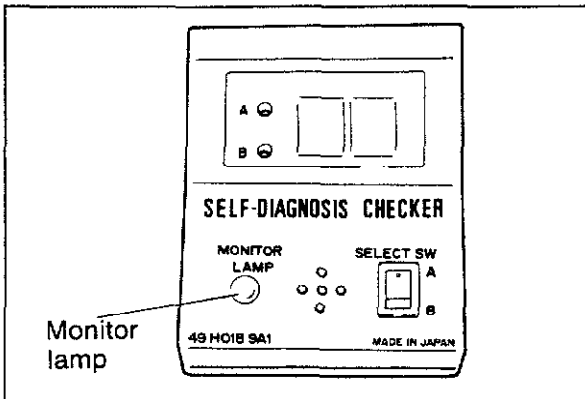

86U04A-208

3. Increase the engine speed to between **2,000 and 3,000 rpm**, and check that the monitor lamp flashes for 10 seconds.

**Monitor lamp: Flashes ON and OFF more than 8 times/10 sec**

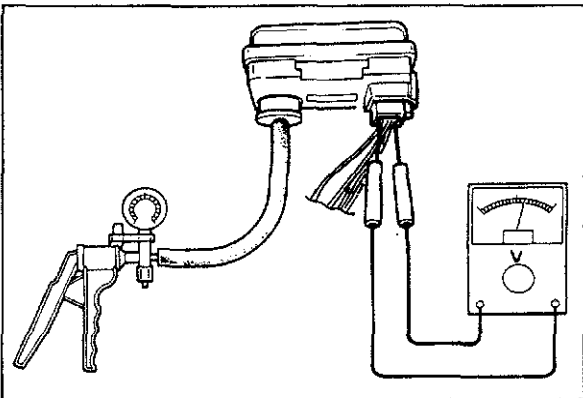

76U04A-052

### ATMOSPHERIC PRESSURE SENSOR Inspection of Terminal Voltage

1. Remove the rubber cap and connect a vacuum pump to the port of the sensor.
2. Turn the ignition switch ON.
3. Check voltage between each terminal and ground while applying and releasing vacuum to the sensor.

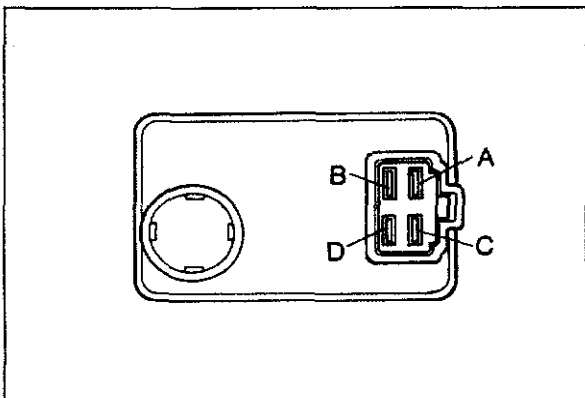

83U04B-154

Terminal (Color)	Voltage
A	—
B (Lg)	1.4—4.9V
C (LgR)	Below 1.5V
D (LgW)	4.5—5.5V

4. If the voltage at C or D terminal is not correct, check the wiring harness.
5. If the voltage of C and D terminal is OK but at B terminal is wrong, replace the atmospheric pressure sensor.

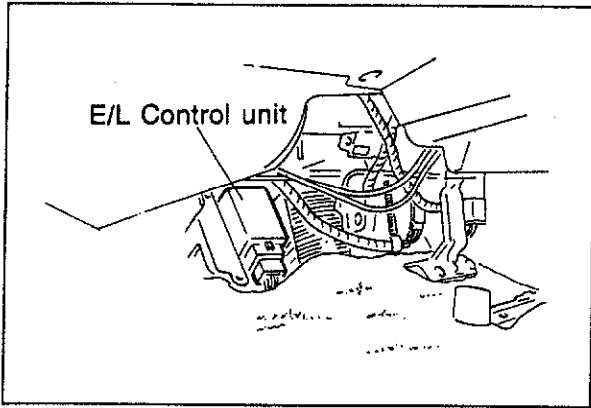

83U04B-155

## ELECTRICAL LOAD (E/L) CONTROL UNIT Inspection

1. Connect a voltmeter between the E/L control unit and ground.
2. Start the engine and check the terminal voltages as described below.

Terminal	Input	Output	Connection to	Voltage (after warm-up)		Remarks
				Ignition switch: ON	Idle	
A (YG)	—	—	Ignition switch	Approx. 12V		
B (YG)	○		Electrical fan relay	Approx. 12V		Coolant temp.: below 97°C (206.6°F)
				Below 1.5V		Coolant temp.: above 97°C (206.6°F)
C (B)	—	—	Ground	0V		
D	—	—	—	—	—	—
E (L)		○	Control unit (1H)	Below 1.5V		E/L: ON
				Approx. 12V		E/L: OFF
F (RB)	○		Combination switch	Approx. 12V		Combination switch: ON
				Below 1.5V		Combination switch: OFF
G (LG)	○		Blower motor switch	Below 1.5V		Blower motor switch: ON (2nd, 3rd or 4th position)
				Approx. 12V		Others
H (BY)	○		Rear defroster switch	Below 1.5V		Rear defroster switch: ON
				Approx. 12V		Rear defroster switch: OFF

83U04B-163

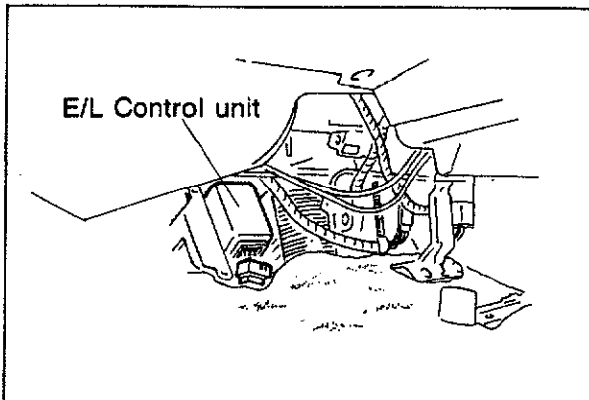

69G04A-175

## Replacement

1. Disconnect the connector from the E/L control unit.
2. Replace the E/L control unit.
3. Install in the reverse order of removal.

## EXHAUST SYSTEM

### REMOVAL

Remove in the sequence shown in the figure.

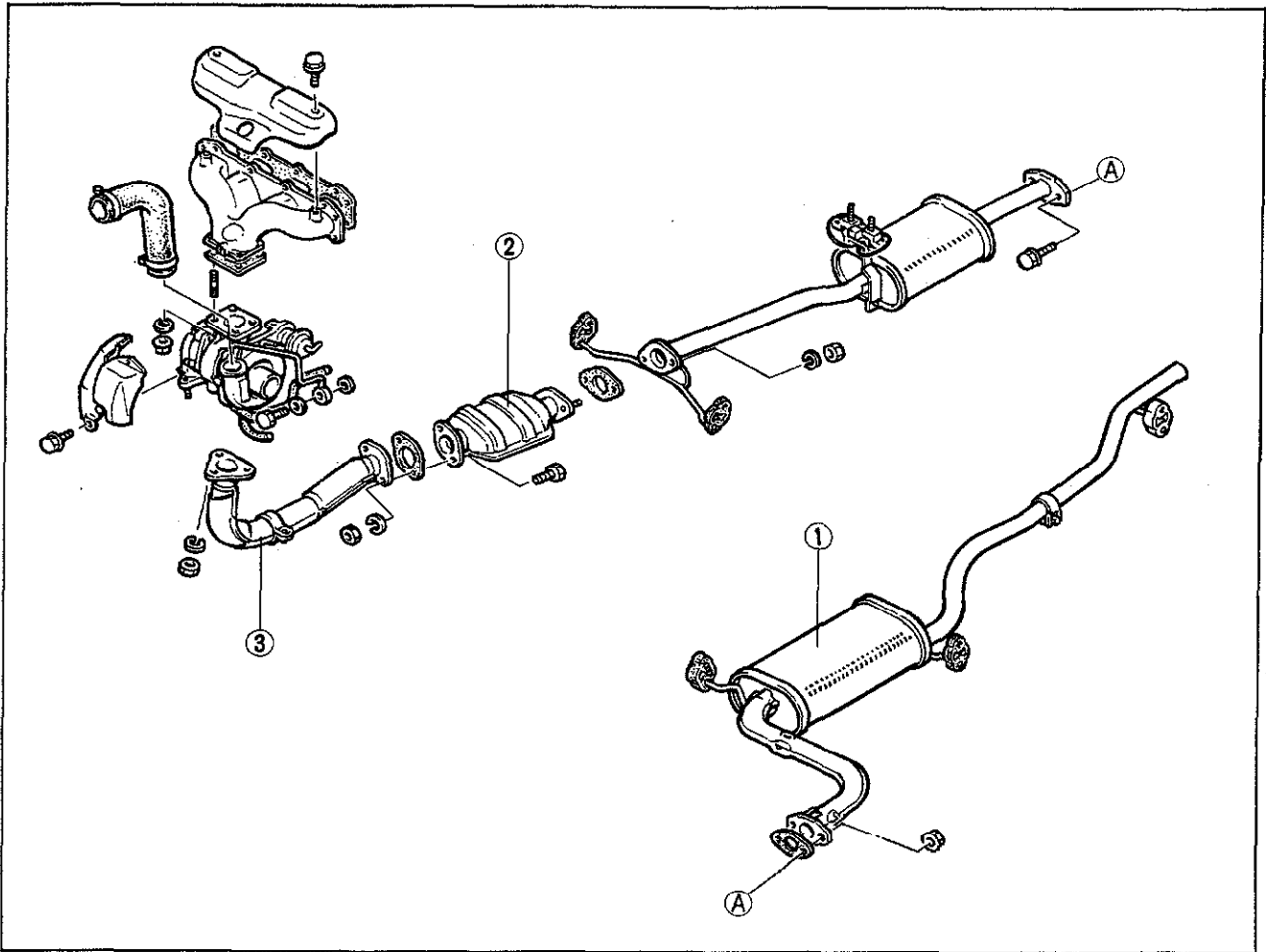

83U04B-156

- 1. Main silencer
- 2. Catalytic converter

- 3. Front exhaust pipe

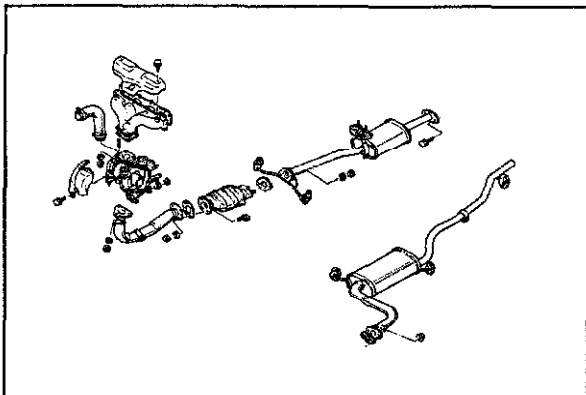

83U04B-157

### INSPECTION

Visually check the exhaust system parts for cracks, or damage.

## INSTALLATION

Install in the reverse order of removal.

### Note

When installing the exhaust system parts, tighten to the specified torque.

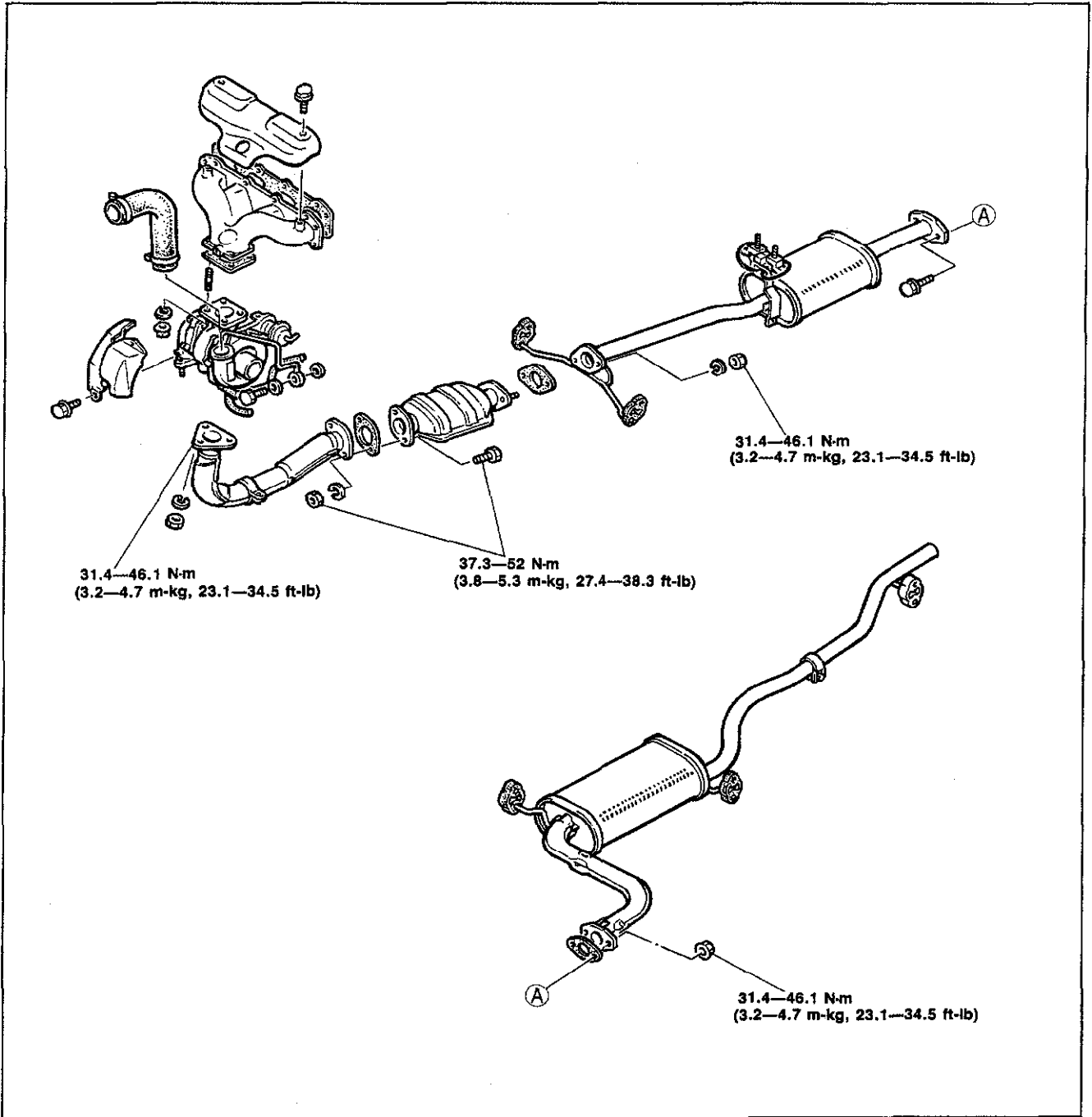

83U04B-158

# ENGINE ELECTRICAL SYSTEM

<b>OUTLINE</b> .....	5- 2	<b>DISTRIBUTOR (NON-TURBO)</b> .....	5-31
STRUCTURAL VIEW.....	5- 2	SPARK TEST .....	5-31
SPECIFICATIONS .....	5- 4	IGNITION TIMING.....	5-31
<b>TROUBLESHOOTING GUIDE</b> .....	5- 5	SPARK ADVANCE CONTROL.....	5-32
<b>BATTERY</b> .....	5- 7	REMOVAL.....	5-33
INSPECTION.....	5- 7	INSTALLATION .....	5-33
RECHARGING .....	5- 7	DISASSEMBLY AND ASSEMBLY.....	5-34
<b>ALTERNATOR</b> .....	5- 8	<b>H.E.I. TROUBLE SHOOTING</b> .....	5-35
CHARGING SYSTEM.....	5- 8	<b>DISTRIBUTOR (TURBO)</b> .....	5-36
ON-VEHICLE INSPECTION.....	5- 9	SPARK TEST .....	5-36
REMOVAL AND INSTALLATION.....	5-14	IGNITION TIMING.....	5-36
INSPECTION.....	5-18	SPARK ADVANCE CONTROL.....	5-37
ASSEMBLY.....	5-21	REMOVAL.....	5-38
<b>STARTER</b> .....	5-22	INSTALLATION .....	5-38
STARTING SYSTEM CIRCUIT .....	5-22	DISASSEMBLY AND ASSEMBLY.....	5-39
ON-VEHICLE INSPECTION.....	5-22	H.E.I. TROUBLESHOOTING	
REMOVAL AND INSTALLATION.....	5-23	(TURBO).....	5-40
DISASSEMBLY AND ASSEMBLY.....	5-23	<b>KNOCK CONTROL SYSTEM</b>	
INSPECTION.....	5-25	<b>(TURBO)</b> .....	5-41
CHECKING OPERATION.....	5-28	INSPECTION OF RETARD	
<b>SPARK PLUGS</b> .....	5-29	FUNCTION .....	5-42
REMOVAL AND INSTALLATION.....	5-29	INSPECTION OF FAIL SAFE	
INSPECTION.....	5-29	FUNCTION .....	5-43
<b>HIGH-TENSION LEADS</b> .....	5-29	INSPECTION OF KNOCK SENSOR..	5-43
INSPECTION.....	5-29	TROUBLESHOOTING.....	5-44
<b>IGNITION COIL</b> .....	5-30		
REMOVAL AND INSTALLATION.....	5-30		
INSPECTION.....	5-30		

## OUTLINE

### STRUCTURAL VIEW (NON-TURBO)

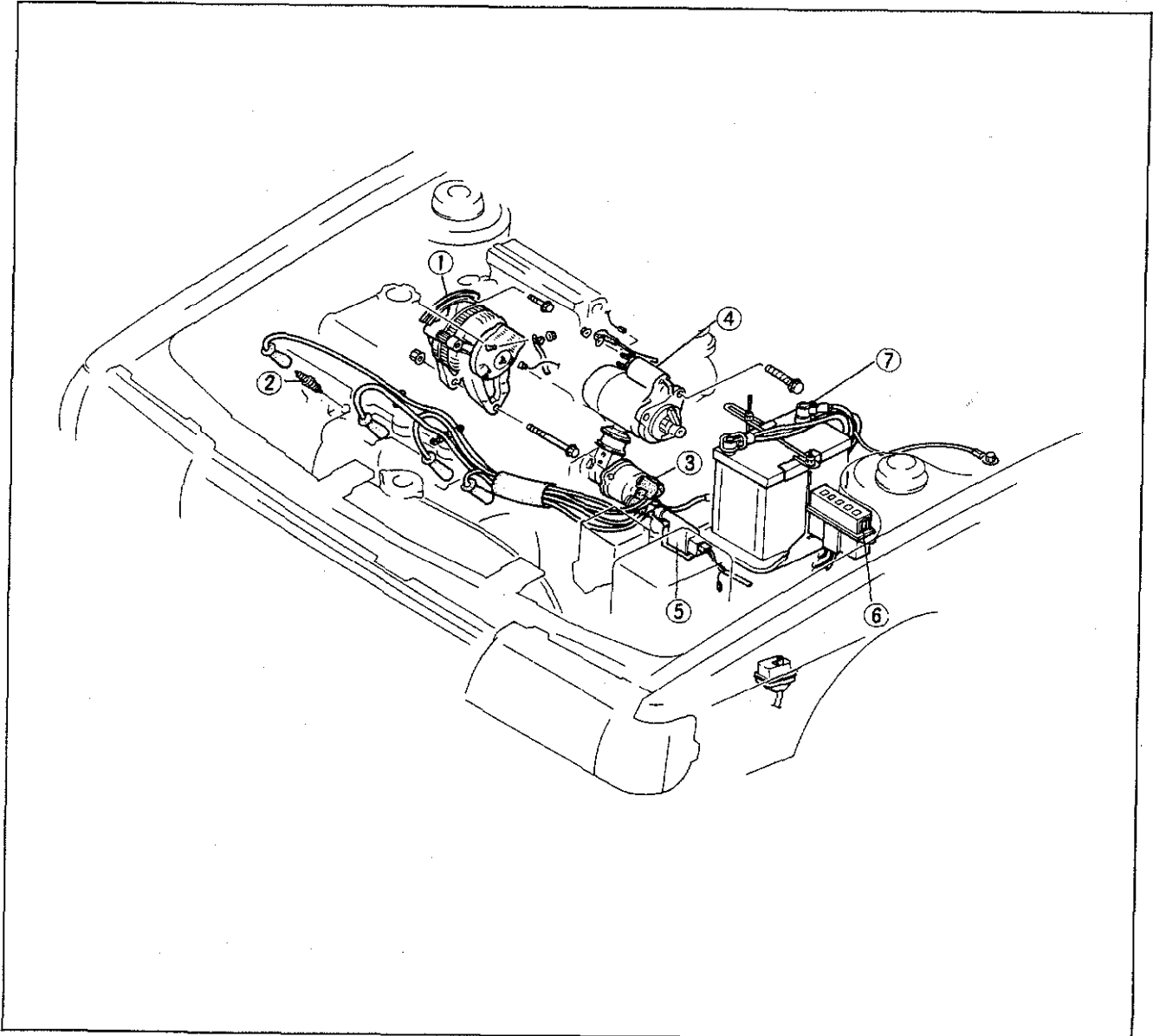

83U05X-002

- 1. Alternator
- 2. Spark plug
- 3. Distributor
- 4. Starter

- 5. Ignition coil
- 6. Main fuse block
- 7. Battery

STRUCTURAL VIEW (TURBO)

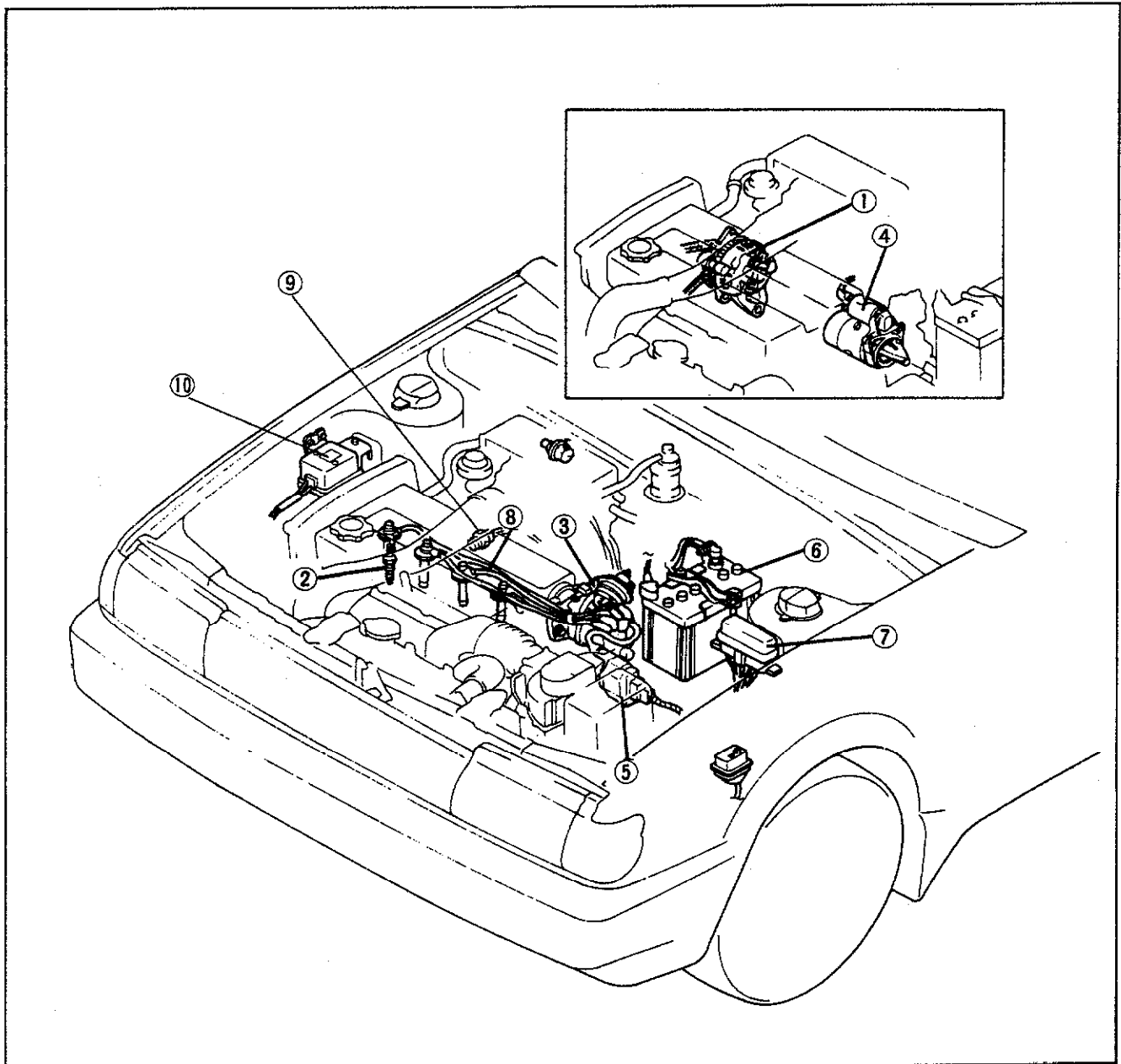

83U05X-003

- 1. Alternator
- 2. Spark plug
- 3. Distributor
- 4. Starter
- 5. Ignition coil

- 6. Battery
- 7. Main fuse block
- 8. High-tension lead
- 9. Knock sensor
- 10. Knock control unit



# 5 OUTLINE

## SPECIFICATIONS

Item		Engine Model	Non-turbo	Turbo
<b>Charging system</b>				
Battery (20 hour rate)	Type		NS40ZAL, 50D20L, 55D23L	
	Voltage	V	12	
	Capacity	Ah	35 (NS40ZAL), 50 (50D20L), 60 (55D23L)	
Level of electrolyte			Between "Upper" and "Lower"	
Safety gravity at 20°C (68°F)	Recharge at		1.20	
	Full charge		1.25—1.27 (NS40ZAL, 50D20L), 1.27—1.29 (55D23L)	
Charging current		A	3.3 (NS40ZAL), 5.0 (50D20L), 6.0 (55D23L)	
Alternator	Type		A-C	
	Voltage-Capacity	V-A	12-60	
Pulley ratio			1 : 2.2	
Load test	Voltage	V	14.1-14.7	
	Current	A	60	
	Speed	rpm	2,500	
Regulator voltage		No load test/ Engine revolution	14.1—14.7/2,500	
Brush	Number		2	
	Length mm (in)	Standard	16.5 (0.650)	
		Wear limit	8.0 (0.315)	
<b>Starting system</b>				
Starter	Type		Electromagnetic, Pull in	
	Voltage	V	12	
	Output	kW	0.85	
Free running test	Voltage	V	11.5	
	Current	A	60 or less	
	Speed	rpm	6,500	
Brush length mm (in)	Standard		17 (0.669)	
	Wear limit		11.5 (0.453)	
<b>Ignition system</b>				
Spark plug	DENSO		W16EXR-U11	Q20PR-U11
	NGK		BPR5ES-11	BCPR6E-11
	CHAMPION		RN11YC4	—
Plug gap		mm (in)	1.0—1.1 (0.039—0.043)	
Ignition advance	Ignition timing (at idle)	BTDC	2 ± 1°	
			12 ± 1°	
			(Vacuum hose: disconnected)	
			Approx. 7°	
			(Vacuum hose: connected)	
Centrifugal spark advance (Crank angle/ Engine speed)			0°/1,300 rpm 19°/3,500 rpm 19°/5,000 rpm	0°/1,200 rpm 12°/3,500 rpm 12°/5,000 rpm 18°/5,500 rpm
Vacuum spark advance (Crank angle/Vacuum)		A chamber 0°/75 mmHg (2.95 inHg) 28°/450 mmHg (17.72 inHg)	B chamber 0°/75 mmHg (2.95 inHg) 5°/150 mmHg (5.91 inHg)	0°/60 mmHg (2.36 inHg) 15°/450 mmHg (17.72 inHg)
Positive pressure spark advance (Crank angle/Positive pressure)			—	0°/10.64 kPa (0.11 kg/cm <sup>2</sup> , 1.54 psi) -5°/53.2 kPa (0.54 kg/cm <sup>2</sup> , 7.7 psi)
Timing mark location			Timing belt cover	
Firing order			1-3-4-2	
<b>Ignition coil</b>				
Secondary coil resistance		kΩ	6—30	
High tension lead resistance		kΩ	16 per 1 m (3.28 ft)	
<b>Distributor</b>				
Type			Full transistor (HEI)	

83U05X-004

**TROUBLESHOOTING GUIDE**

Problem	Probable Cause	Remedy
<p><b>Starter does not turn, or speed too slow to start the engine.</b></p>	<p>Battery and related parts                      Poor contact of battery terminal(s)                      Poor ground of negative cable                      Voltage drop caused by discharged battery                      Insufficient voltage caused by battery malfunction                      Ignition switch and related parts                      Poor contact of ignition switch                      Loose ignition switch wiring or connector                      Broken wire between ignition switch and magnetic switch                      Magnetic switch and related parts                      Loose wiring and/or connectors                      Burnt magnetic switch contact plate or improper contact                      Broken wire in magnetic switch pull-in coil                      Broken wire in magnetic switch holding coil                      Starting motor and related parts                      Poor contact of brushes                      Fatigued brush spring                      Poor ground of field coil                      Poor soldering of field coil                      Commutator malfunction                      Grounded armature                      Worn parts</p>	<p>Clean and tighten                      Clean and repair                      Recharge                      Replace                      Replace                      Repair                      Repair or replace                      Repair                      Replace                      Replace                      Replace                      Adjust or replace                      Replace                      Replace                      Repair                      Repair                      Replace                      Replace</p>
<p><b>Starter turns but engine does not start</b></p>	<p>Insufficient battery capacity                      Malfunction of spark plug(s)                      Loose primary wiring                      Damaged distributor cap or rotor                      Ignition coil malfunction                      Knock control unit malfunction</p>	<p>Recharge                      Clean, adjust, or replace                      Tighten                      Replace                      Replace                      Replace</p>
<p><b>Starter motor turns but pinion gear does not engage ring gear</b></p>	<p>Tip of overrunning clutch pinion worn                      Fatigued overrunning clutch drive spring                      Overrunning clutch freewheels                      Pinion sticking on spline                      Worn bushing                      Worn ring gear</p>	<p>Replace                      Replace                      Replace                      Repair or replace                      Replace                      Replace</p>

83U05X-005

# 5 TROUBLESHOOTING GUIDE

Problem	Probable Cause	Remedy
<b>Starter motor turns continuously (does not stop)</b>	Sticking magnetic switch contact plate Short of magnetic switch coil Ignition switch does not return	Replace Replace Replace
<b>Misfiring of engine</b>	Dirty or damaged spark plug(s) Malfunction of wiring, or poor wiring contact Damaged distributor cap Knock control system malfunction	Clean or replace Replace Replace Replace
<b>Discharging of battery</b>	Loose V-belt Grounded or broken stator coil Broken rotor coil Poor contact of brush and slip ring Malfunction of rectifier Malfunction of IC regulator Insufficient battery electrolyte Malfunction of battery electrode (internal short circuit) Poor contact of battery terminal(s) Excessive electrical load	Adjust Replace Replace Clean or replace Replace Replace Adjust Replace Clean and tighten Check
<b>Overcharging of battery</b>	IC regulator malfunction	Replace
<b>Poor acceleration</b>	Incorrect adjustment of ignition timing Distributor malfunction Knock control system malfunction	Adjust Repair or replace Repair or replace
<b>Knocking</b>	Incorrect adjustment of ignition timing Distributor malfunction Knock control system malfunction	Adjust Repair or replace Repair or replace

83U05X-006

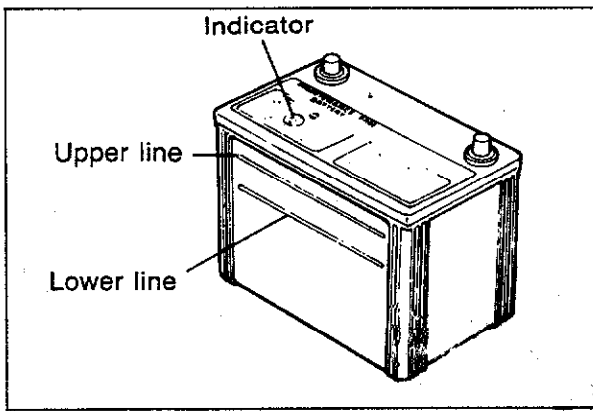

5BU05X-046

## BATTERY

### INSPECTION

#### Indicator sign

1. Check the indicator sign on the top of the battery. If the indicator sign is blue, the battery is normal.
2. If the blue indicator sign is not visible, then the electrolyte level of the battery is low and/or the capacity is insufficient.
3. Check whether or not the electrolyte level lies between the upper and lower lines. If low, add distilled water. Do not overfill. If the electrolyte level is acceptable and yet the blue indicator sign is not visible, the battery must be recharged.

#### Terminal and cable

1. Check the tightness of the terminals to ensure good electrical connections. Clean the terminals and coat them with grease.
2. Inspect for corroded or frayed battery cables.
3. Check the rubber protector on the positive terminal for proper coverage.

Specific gravity of electrolyte at 20°C (68°F)		Charged rate (%)
50D20L NS40ZAL	55D23L	—
1.260	1.280	100
1.220	1.220	75

83U05X-007

### RECHARGING

#### Quick charging

Remove the battery from the vehicle and remove all the vent caps to perform a quick charge (6A or above, but max. 20A).

#### Slow charging

It is not necessary to remove the vent caps to perform a slow charge (under 5A).

#### Warning

- a) Before performing maintenance or recharging of battery, turn off all accessories and stop the engine.
- b) The negative cable should be removed first and installed last.

#### Note

- a) If the indicator sign does not turn blue even after being charged, then measure the specific gravity with a hydrometer. If the specific gravity is under 1.220, charge once more.
- b) If the indicator sign does not turn blue when the specific gravity is normal, the indicator could be defective.

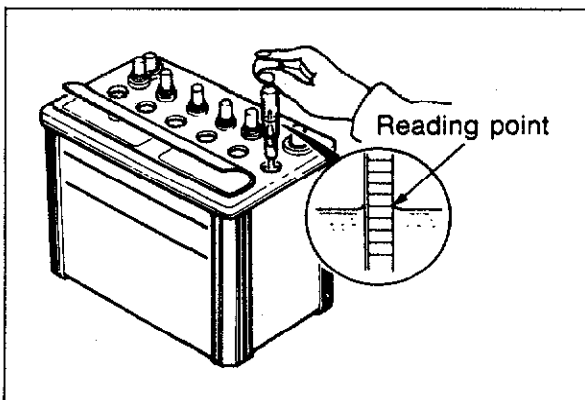

5BU05X-047

# 5 ALTERNATOR

## ALTERNATOR

### CHARGING SYSTEM

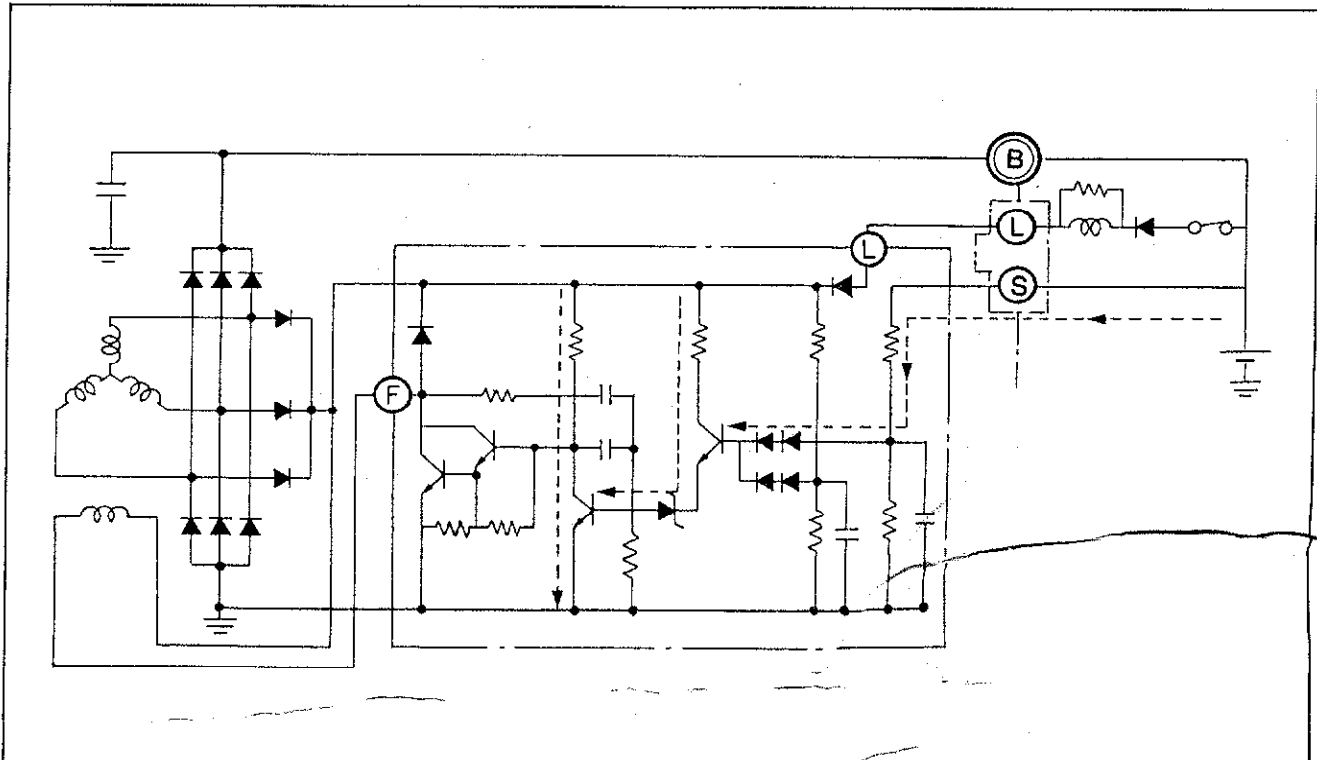

5BU05X-048

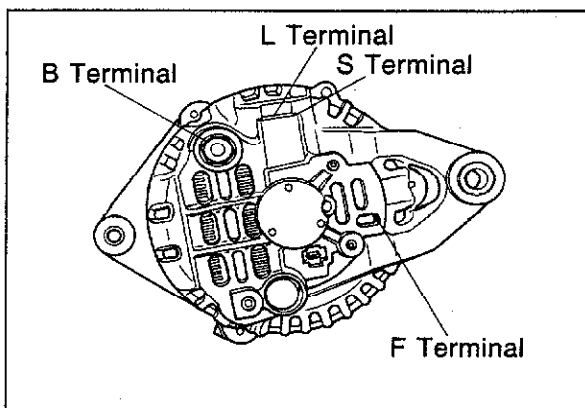

83U05X-008

#### Caution

- Be sure battery connections are not reversed, because this will damage the rectifier.
- Do not use high-voltage testers, such as a megger, because they will damage the rectifier.
- Remember that battery voltage is always applied to the alternator (B) terminal.
- Do not ground the (L) terminal while the engine is running.
- Do not start the engine while the coupler is disconnected from the (L) and (S) terminals.

## TROUBLESHOOTING

### Preliminary Check

1. Check the indicator on the top of the battery. If the indicator is blue, the battery is normal.
2. If the indicator is not blue, the electrolyte level of the battery is low, or capacity is insufficient, or both. (Refer to page 5—7)  
Charge the battery until the indicator becomes blue, or replace the battery with a fully charged one.
3. Turn the ignition switch ON, and check that the alternator warning light illuminates.
4. Start the engine, and check that the alternator warning light goes off.

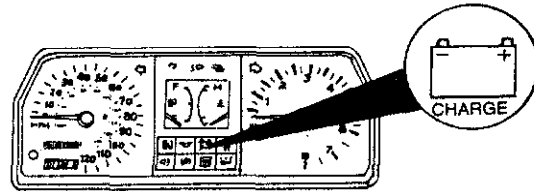

83U05X-023

### 1. Alternator warning light always not illuminate

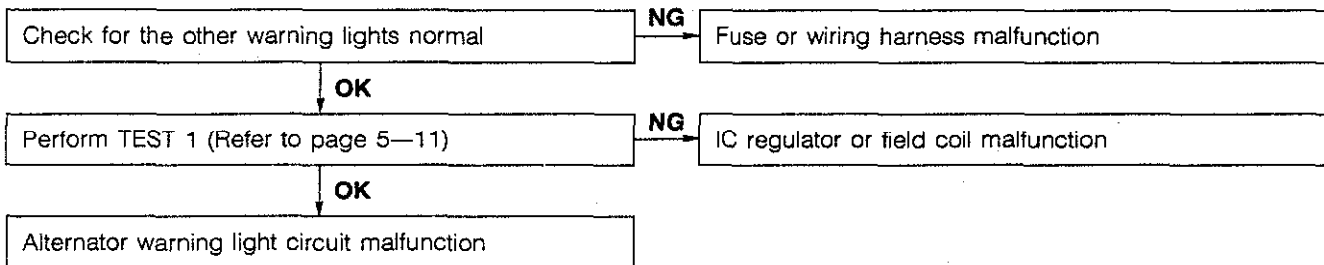

73G05X-027

### 2. Alternator warning light illuminates when engine running

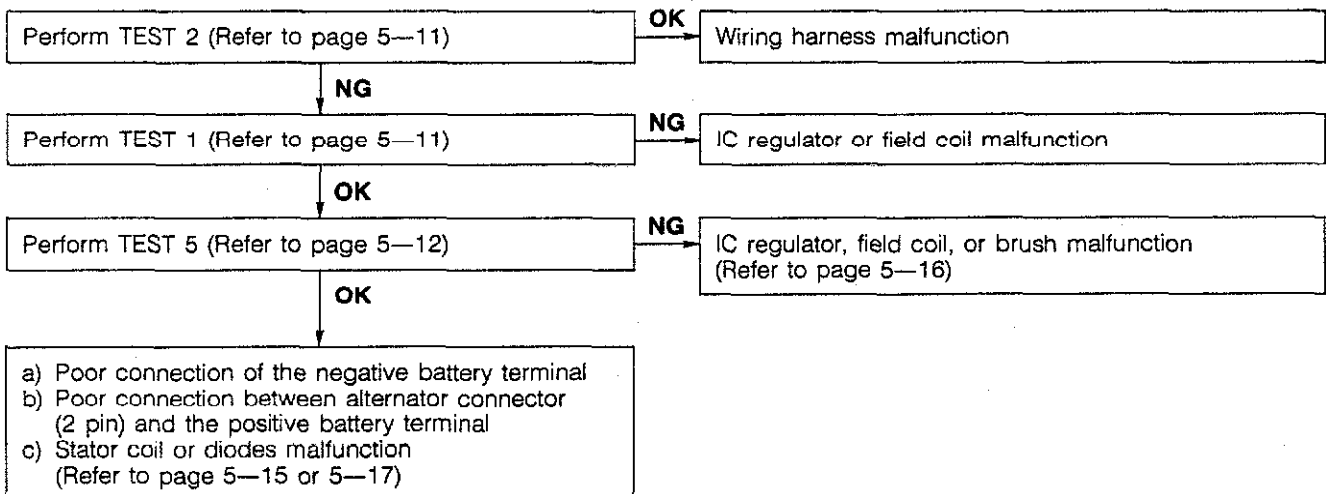

73G05X-028

# 5 ALTERNATOR

## 3. Alternator warning light operates properly, but battery discharged

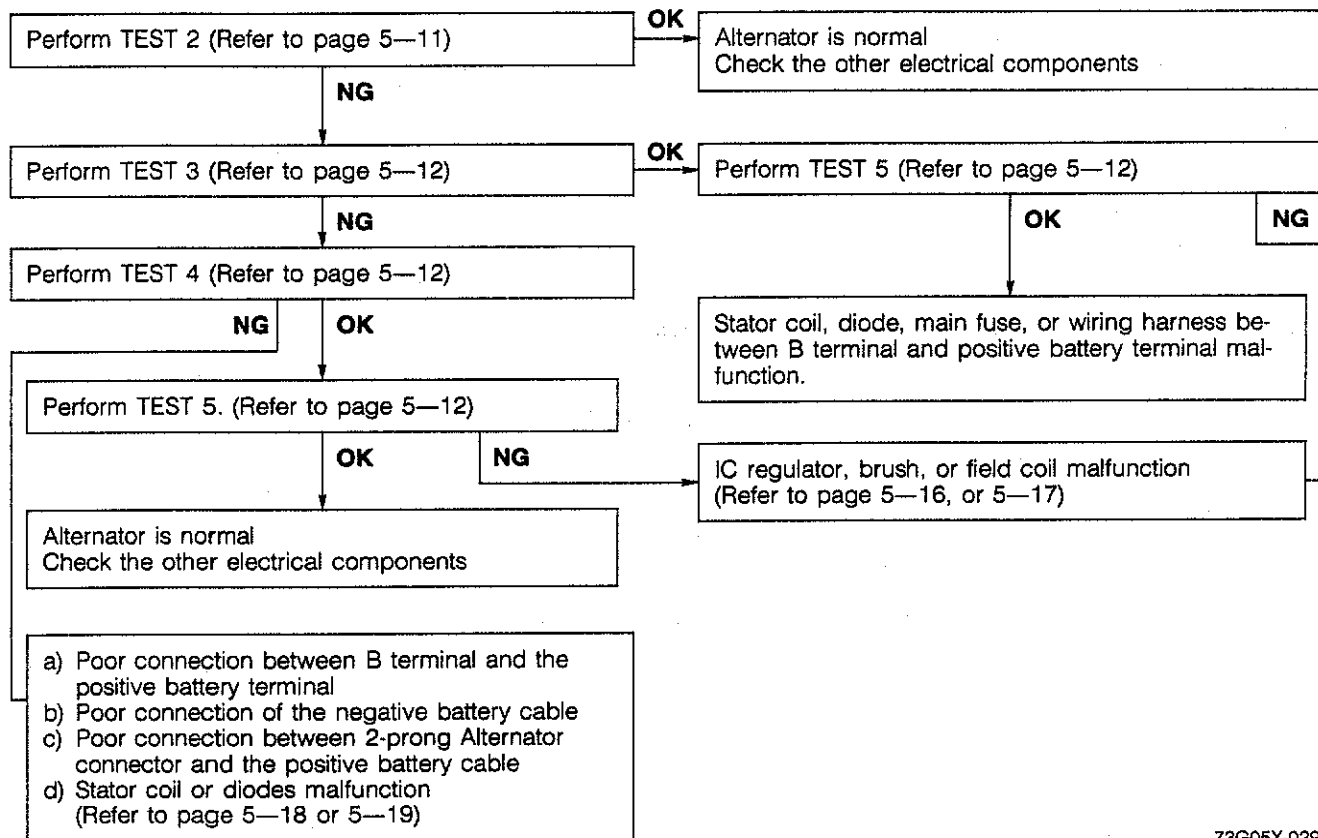

73G05X-029

## 4. Battery overcharged

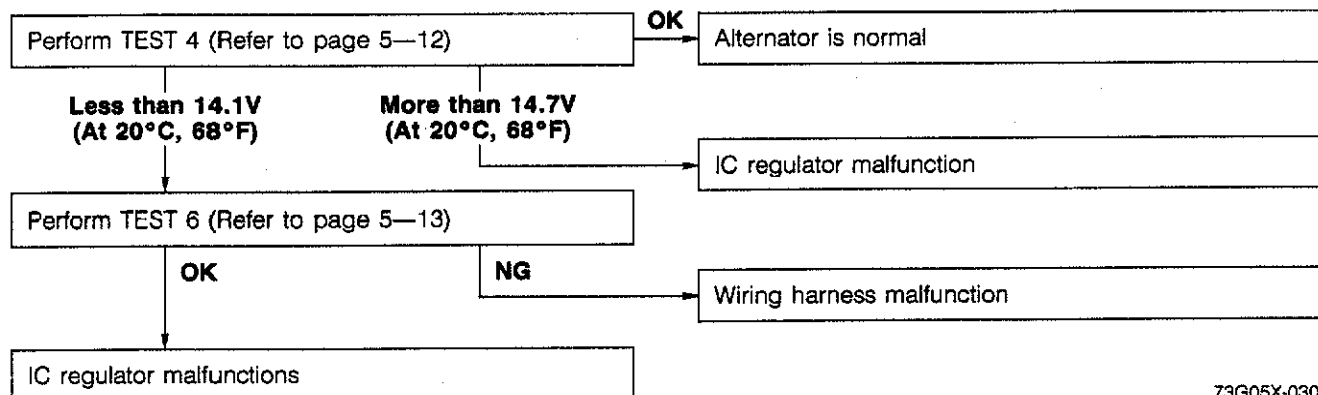

73G05X-030

**Warning**

Disconnect the negative battery terminal when disconnecting or reconnecting B terminal.

**TEST 1**

1. Disconnect the alternator connector (2-pin).
2. Connect the **SST**.

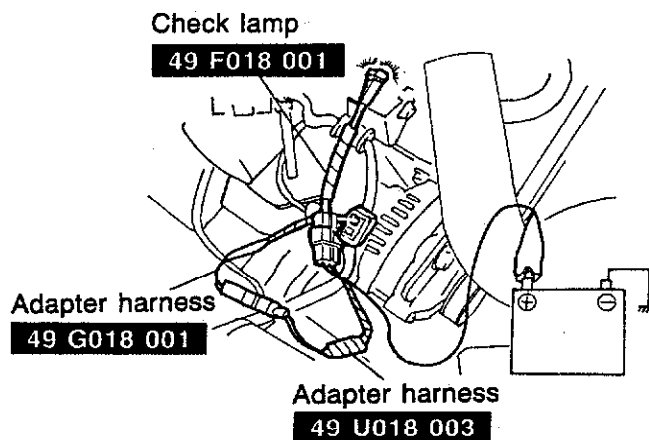

3. Connect the red clip of the adapter harness to the battery (+), and check that the red lamp and green lamp illuminate.
4. Start the engine and check that both lamps go off.

86U05X-010

**TEST 2**

1. Connect an ammeter (**60A min.**) between the wire and the B terminal.
2. Turn all headlights and accessories on, and depress the brake pedal.
3. Start the engine and check that output current is **60A or more** at **2,500—3,000 rpm** of the engine speed.

**Caution**

**Do not ground the B terminal.**

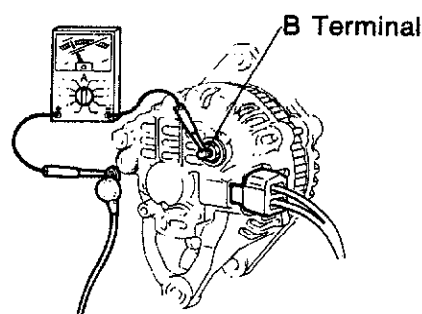

83U05X-024



# 5 ALTERNATOR

## TEST 3

1. Turn all electric loads off and release the brake pedal.
2. Check that output current is **5A or more** at **2,500—3,000 rpm** of the engine speed.

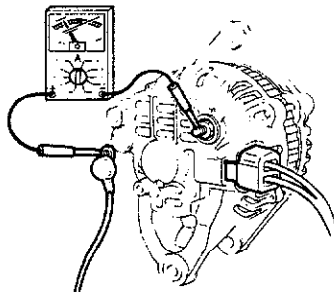

86U05X-013

## TEST 4

1. Turn all electric loads off and release the brake pedal.
2. Check that output voltage between S terminal and ground is within specification at **2,500—3,000 rpm** of the engine speed.

**Voltage: 14.1—14.7V**

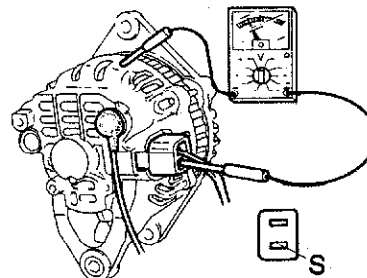

86U05X-072

## TEST 5

1. Turn the ignition switch ON.
2. Check that L terminal voltage is within specification.

**Voltage: 1—5V**

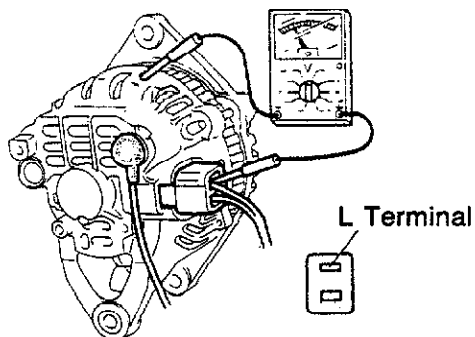

86U05X-073

**TEST 6**

1. Turn the ignition switch ON.
2. Turn all electric loads off and release the brake pedal.
3. Check that voltage between S terminal and ground is battery voltage.

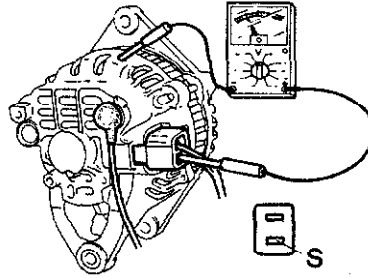

86U05X-074

# 5 ALTERNATOR

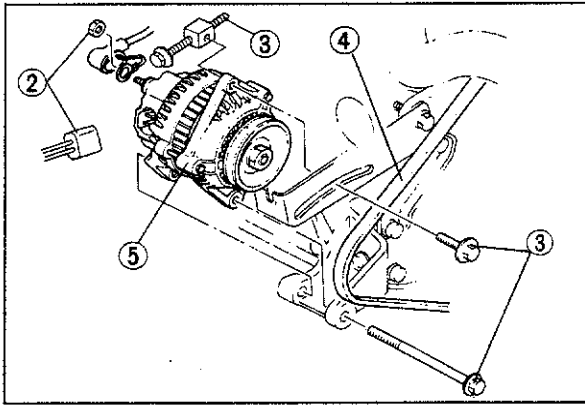

83U05X-010

## REMOVAL AND INSTALLATION

1. Disconnect the negative battery terminal.
2. Disconnect the wire and connector from the alternator.
3. Remove the bolts.
4. Remove the V-belt
5. Alternator
6. Install in the reverse order of removal.

### Tightening torque:

**Adjusting bolt: 19—24 N·m**  
(1.9—2.6 m·kg, 14—19 ft·lb)

**Installation bolt: 37—52 N·m**  
(3.8—5.3 m·kg, 27—38 ft·lb)

7. Adjust the tension of the V-belt.

### Deflection

**New belt: 8—9 mm (0.31—0.35 in)**

**Used belt: 9—10 mm (0.35—0.39 in)**

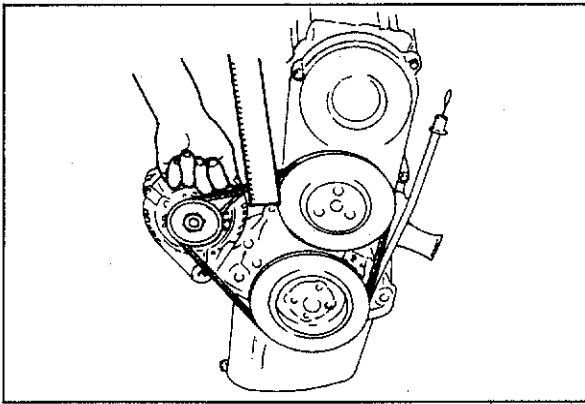

83U05X-011

## DISASSEMBLY

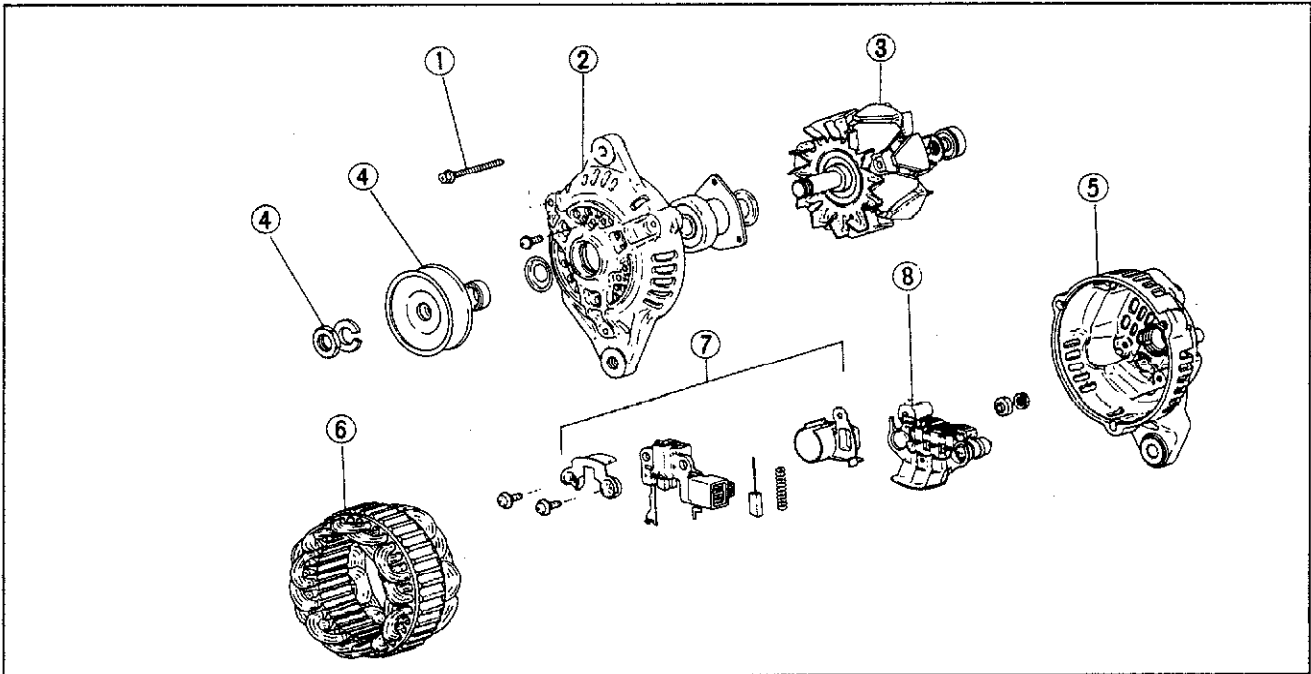

5BU05X-005

1. Bolt
2. Front bracket
3. Rotor and fan

4. Lock-nut and Pulley
5. Rear housing
6. Stator

7. Brush-holder assembly
8. Rectifier

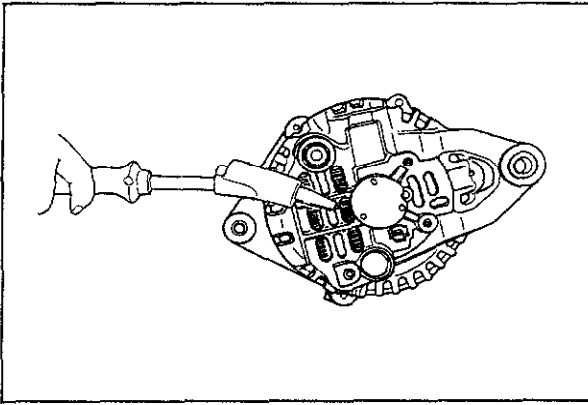

83U05X-012

1. Place a soldering iron (200W class) on the bearing box for **3 or 4 minutes** and heat it to about **50–60°C (122 & 140°F)**.

Next, pull out the three bolts, and then insert a flat-tip screwdriver between the stator and front bracket and separate them.

**Note**

- a) If the bearing box is not heated, the bearing cannot be pulled out, because the rear bearing and rear bracket fit together very tightly.
- b) Be careful not to force the screwdriver in too far, because the stator may become scratched.

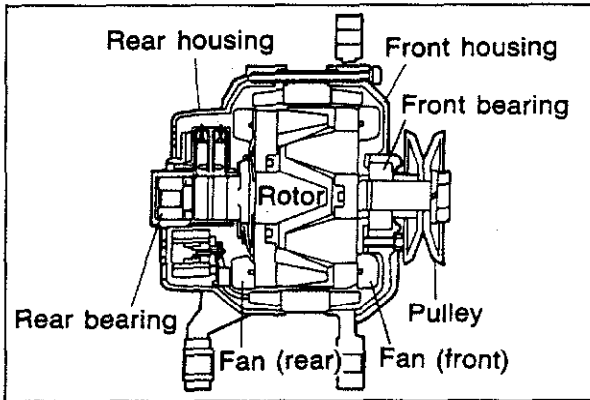

63U05X-999

2. Separate the rear and front sections.

**Note**

Be careful not to lose the stopper spring that fits around the circumference of the rear bearing.

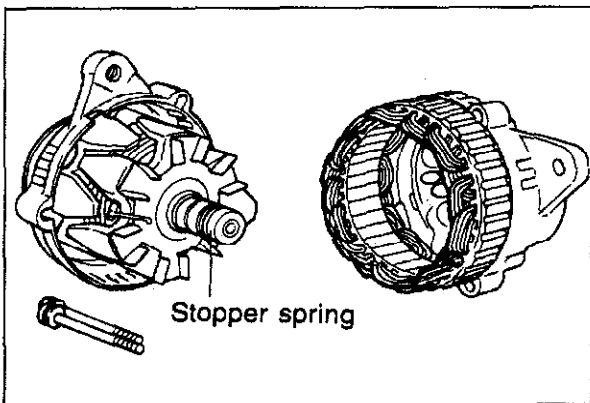

58U05X-057

3. Place the rotor in a vise and loosen the pulley nut, then disassemble the pulley, rotor and front housing.

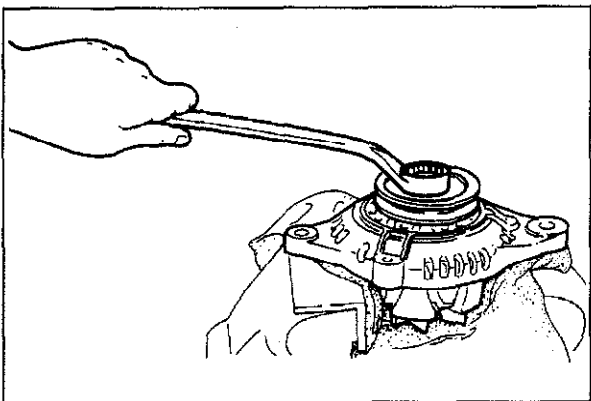

63U05X-016

# 5 ALTERNATOR

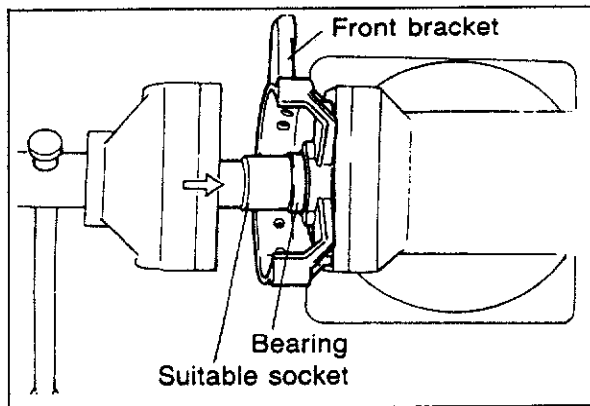

5BU05X-058

4. Replace the front bearing  
Using a socket which exactly fits on the outer race of the bearing, carefully press in the bearing. Use a hand press or a vice.

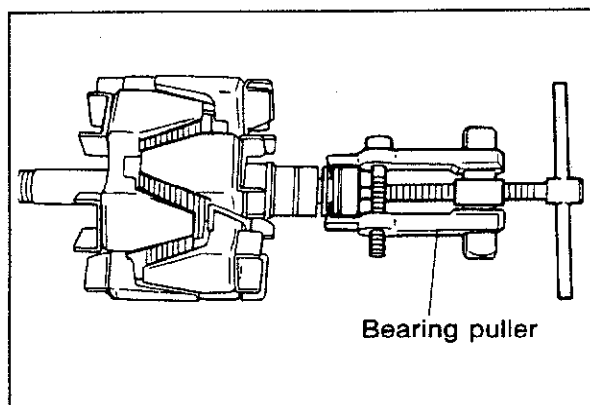

5BU05X-059

5. Replace the rear bearing  
The bearing can be pulled off by using a bearing puller.  
When it is pressed on, press it on so that the groove at the bearing circumference is at the slip ring side.

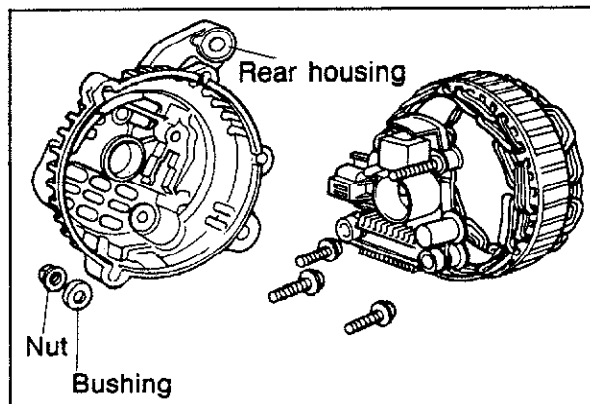

5BU05X-060

6. Remove the nut of the B terminal and the insulation bushing.
7. Remove the rectifier holding screws and the brush holder holding screw.
8. Separate the rear bracket and stator.

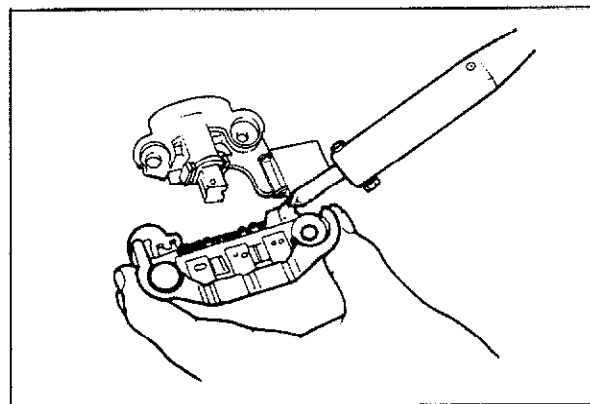

9. Use a soldering iron to remove the solder from the rectifier and the stator leads, and then remove the IC regulator.

**Caution**  
Disconnect quickly, use the soldering iron no more than about 5 seconds because the rectifier may be damaged if it is overheated.

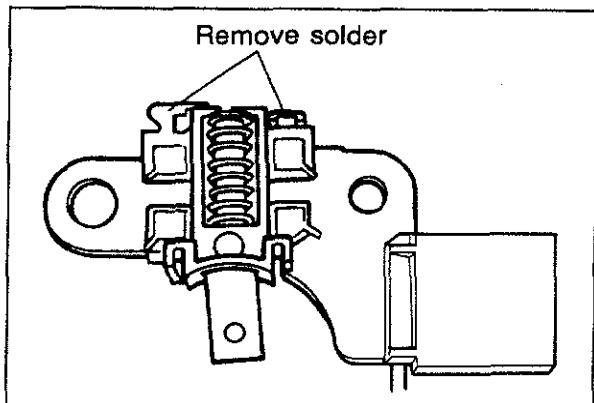

83U05X-026

10. Replace the brushes  
Remove the solder from the pigtail, and then remove the brush.

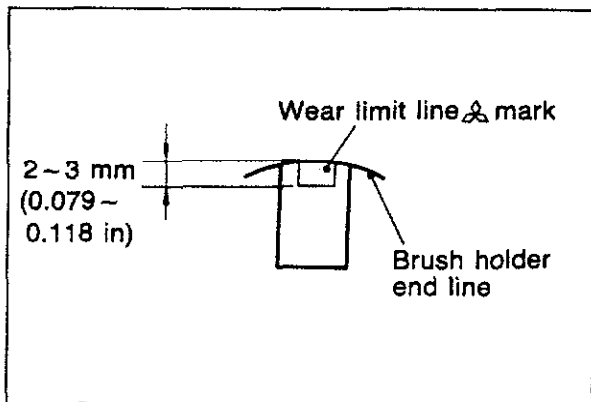

83U05X-027

11. When soldering the brush, solder the pigtail so that the wear limit line of the brush projects **2—3 mm (0.079—0.118 in)** out from the end of the brush holder.

# 5 ALTERNATOR

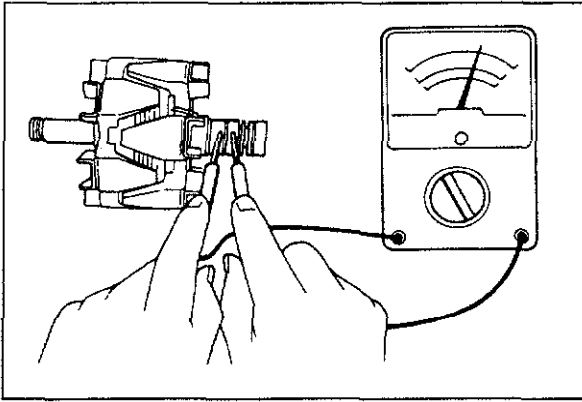

5BU05X-062

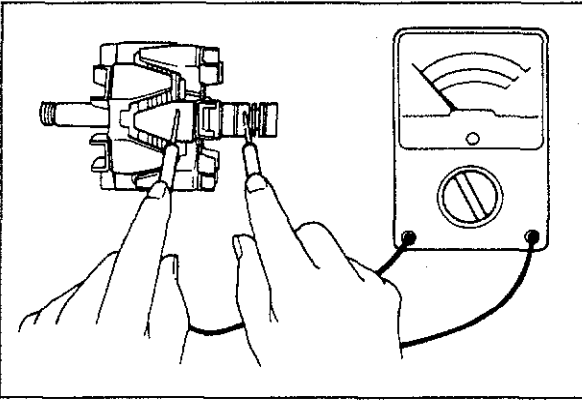

5BU05X-063

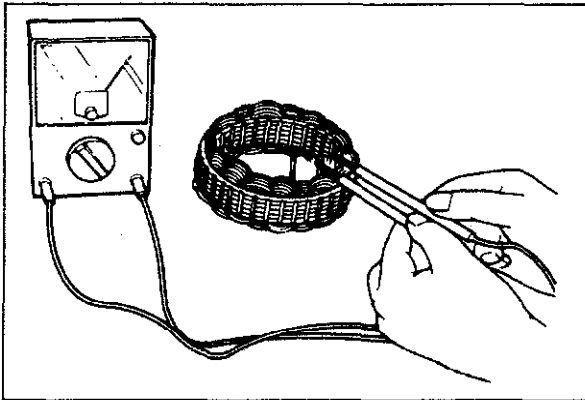

5BU05X-064

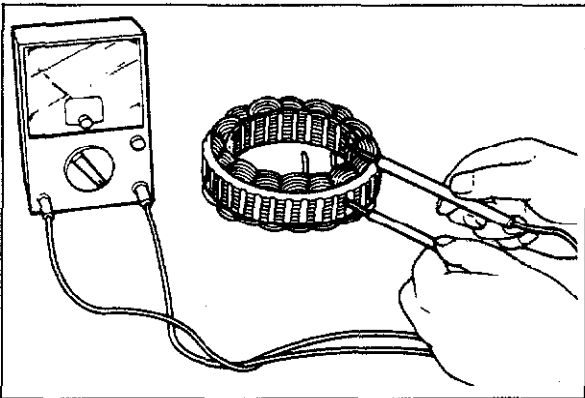

5BU05X-065

## INSPECTION

### Rotor

1. Wiring damage
  - (1) Measure the resistance between the slip rings by using a circuit tester.
  - (2) If it is not within standard resistance, replace the rotor.

**Standard resistance: 2.0—2.6  $\Omega$**

2. Ground of the rotor coil
  - (1) Check for continuity between the slip ring and the core by using a circuit tester.
  - (2) Replace the rotor if there is continuity.
3. Slip ring surface  
If the slip ring surface is rough, use a lathe or fine sandpaper to repair it.

### Stator

1. Wiring damage
  - (1) Check for continuity between the stator coil leads by using a circuit tester.
  - (2) Replace the stator if there is no continuity.

2. Ground of the stator coil
  - (1) Check for continuity between the stator coil leads and the core by using a circuit tester.
  - (2) Replace the stator if there is continuity.

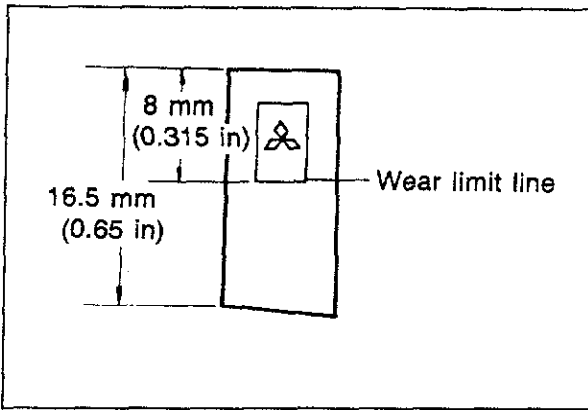

5BU05X-066

## Brush

If the brushes are worn almost to or beyond the limit, replace them.

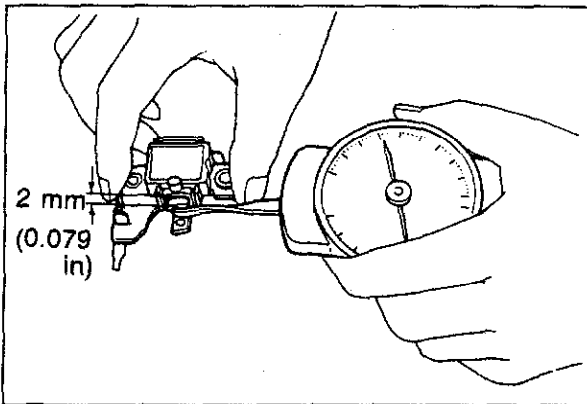

5BU05X-067

## Brush spring

Measure the force of the brush spring by using a spring pressure gauge. Replace the spring if the force is **2.0 N (210g, 7.4 oz)** or less. When making the measurement, use the spring pressure gauge to push the brush into the brush holder until the tip projects **2 mm (0.079 in)**, and read the force at that time.

## Note

**For a new brush the force is 2.9—4.3 N, (300—440g, 10.6 — 15.5 oz).**

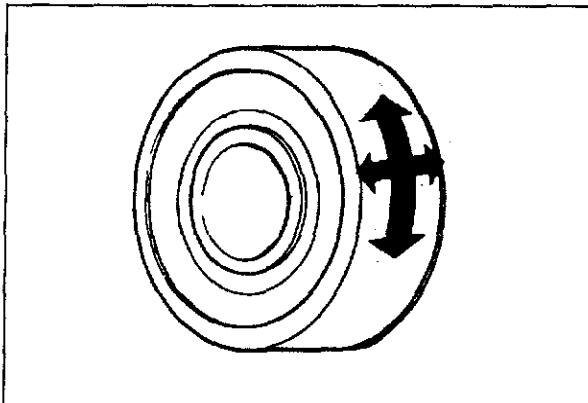

5BU05X-068

## Bearing

1. Check for abnormal noise, looseness, insufficient lubrication, etc.
2. Replace the bearing(s) if there is any abnormality.

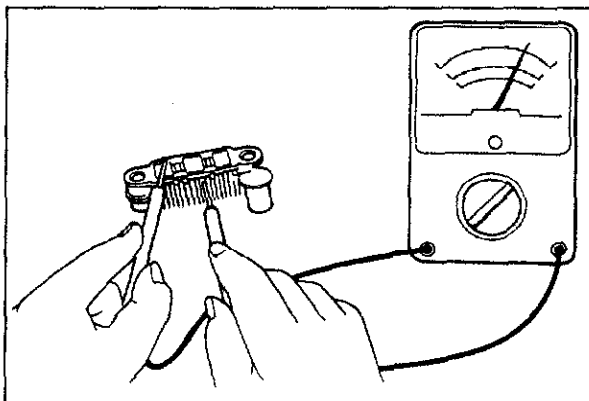

5BU05X-069

## Rectifier

1. Positive diode

Check for continuity between the diode lead and the heat sink at the positive side, using an ohmmeter. There should be continuity only in the direction from the diode lead to the heat sink.



# 5 ALTERNATOR

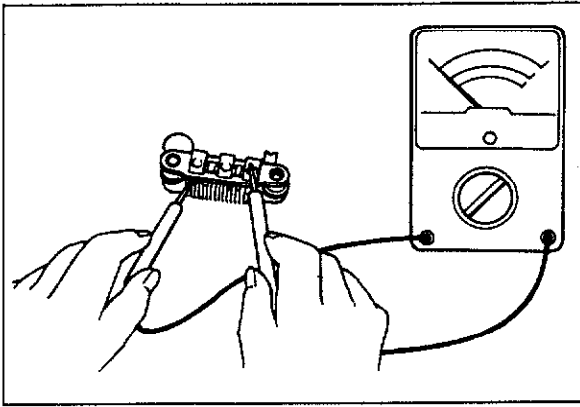

5BU05X-070

## 2. Negative diode

Check for continuity between the diode lead and the heat sink at the negative side. There should be continuity only in the direction from the heat sink to the diode.

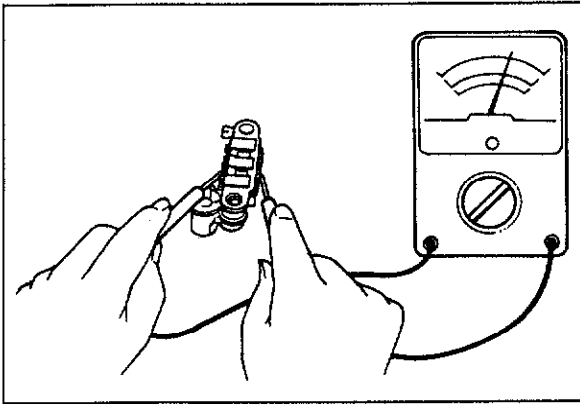

5BU05X-071

## 3. Trio diode

Check for continuity by using a circuit tester. There should be continuity in one direction only.

## ASSEMBLY

Assemble in the reverse order of disassembly. There are no lubrication points.

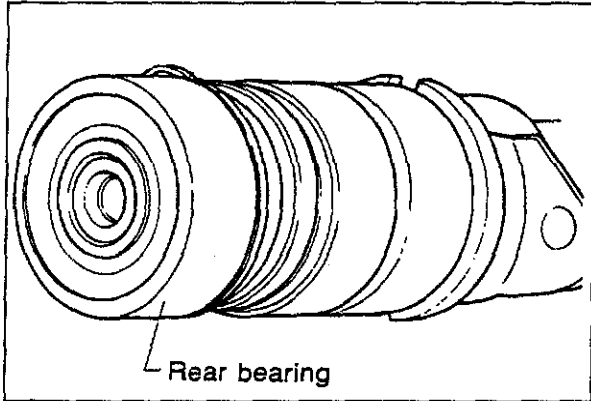

63U05X-018

1. Fit the stopper spring into the eccentric groove of the rear bearing circumference. The protruding part of the spring should fit into the deepest part of the groove. Note that, for easy recognition, the edge of the deepest part of the groove is chamfered.

### Note

**By fitting the stopper spring in this way, the amount of spring protruding from the groove is lessened so that assembly becomes easier. In addition, no strain is exerted on the spring and thus its stopping effect becomes greater.**

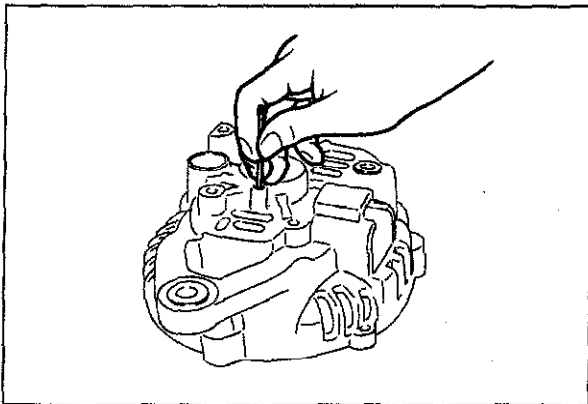

5BU05X-074

2. Brush lifting

Before assembly, use a finger to push the brush into the brush holder, pass a wire ( $\phi$  2 mm, 40—50 mm [ $\phi$  0.08 in, 1.6—2.0 in]) through the hole shown in the figure, and secure the brush in position.

### Note

**Be sure to pull the wire out after assembly is completed.**

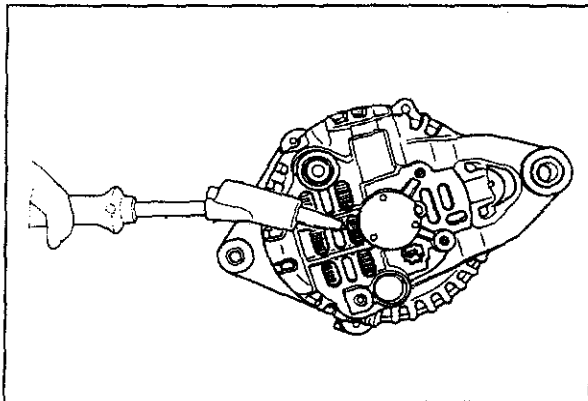

5BU05X-075

3. When the rear bearing is pressed into the rear bracket, first heat the bracket before pressing it in.
4. After assembly is completed, rotate the pulley manually and check that the rotor turns easily.

## STARTER

### STARTING SYSTEM CIRCUIT

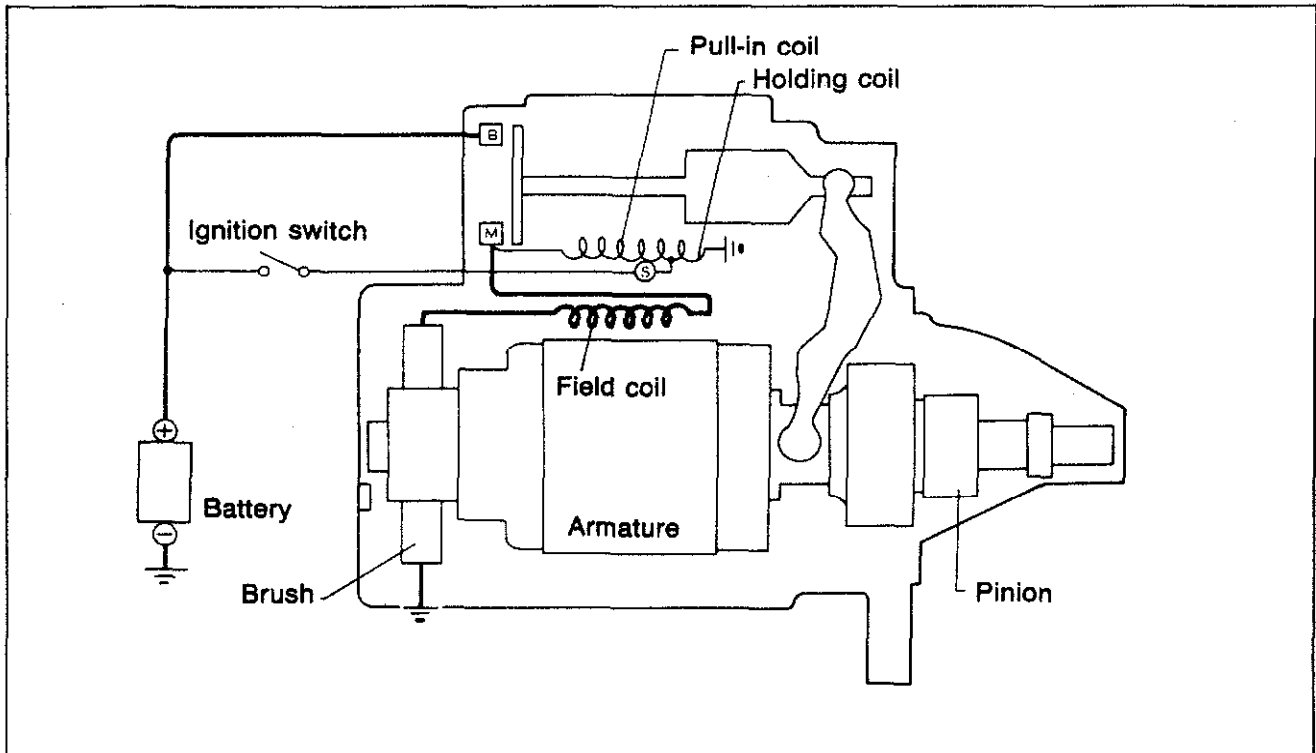

63U05X-008

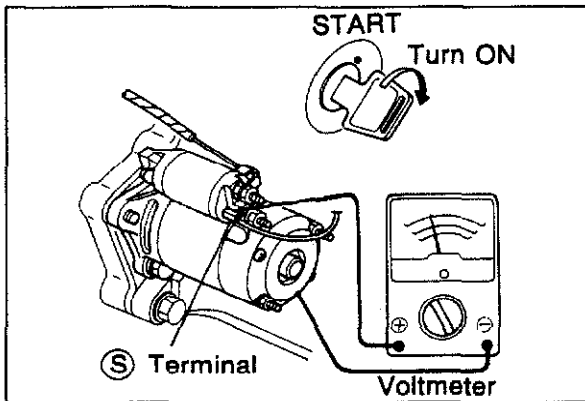

63U05X-019

#### ON-VEHICLE INSPECTION

Before this inspection, measure the specific gravity of the battery. Check that it is fully-charged or nearly fully-charged.

#### A. If the magnetic switch doesn't function during starting

With the ignition key switch at the start position, measure the voltage between the S terminal and ground. If it is 8V or more, there is a starter malfunction; if it is less than 8V, there is a malfunction in the wiring.

#### Caution

**If the magnetic switch is hot, it may not function even though the voltage is 8V or more.**

#### B. If the starter won't crank, or if the cranking speed is slow

The problem may be a malfunction of the starter or in the wiring. Repeat test A above, if voltage is 8V or more, or if headlights dim when starter is operated, remove the starter for detailed inspection.

#### Note

**The cranking speed is greatly affected by the viscosity of the engine oil.**

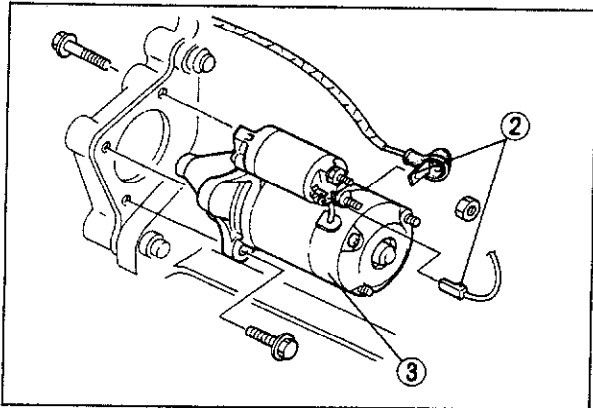

63U05X-020

## REMOVAL AND INSTALLATION

Remove as follows:

1. Disconnect the negative battery cable.
2. Disconnect the wiring from the starter.
3. Remove the starter.

Install in the reverse order of removal.

**Tightening torque: 31—41 N·m  
(3.2—4.7 m·kg, 23—34 ft·lb)**

## DISASSEMBLY AND ASSEMBLY

Disassemble in the numbered order shown in the figure. Assemble in the reverse order of disassembly.

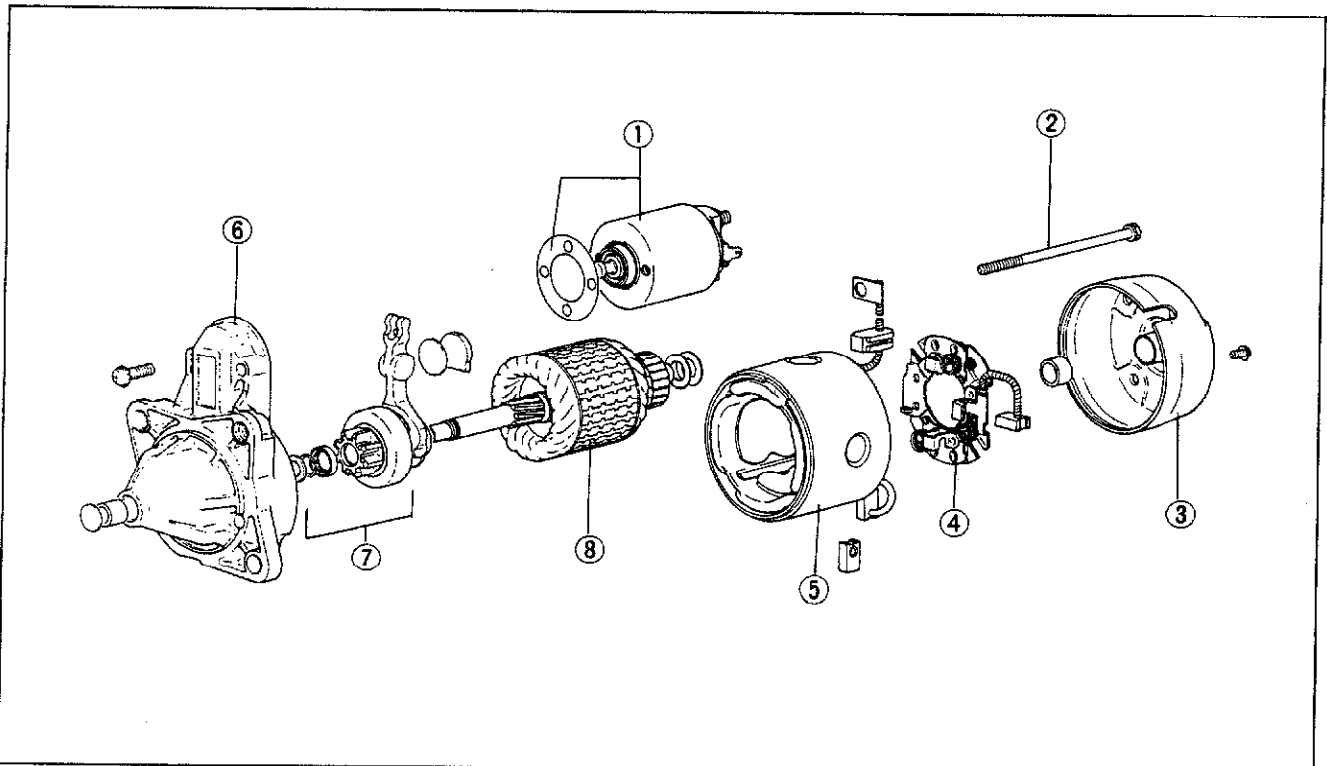

63U05X-021

1. Magnetic switch
2. Bolt
3. Rear cover

4. Brush-holder assembly
5. Yoke
6. Drive housing (front cover)

7. Drive pinion
8. Armature

# 5 STARTER

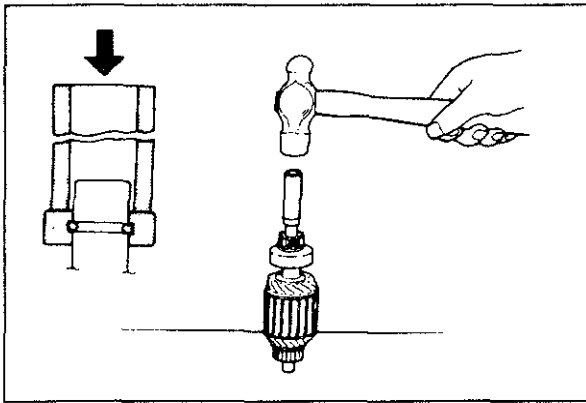

## Drive pinion

Remove the stopper for the overrunning clutch by using a pipe as shown in the figure.

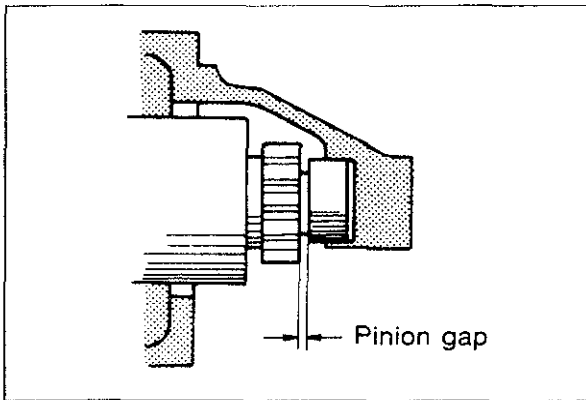

## Adjustment of pinion gap

1. Disconnect the wiring from terminal (M).
2. When the battery is connected between terminal (S) and the starter body, the pinion will eject outward and then stop. Then measure the clearance (pinion gap) between the pinion and the stopper. Do not operate the starter for more than 20 seconds.

## Pinion gap:

**0.5—2.0 mm (0.020—0.079 in)**

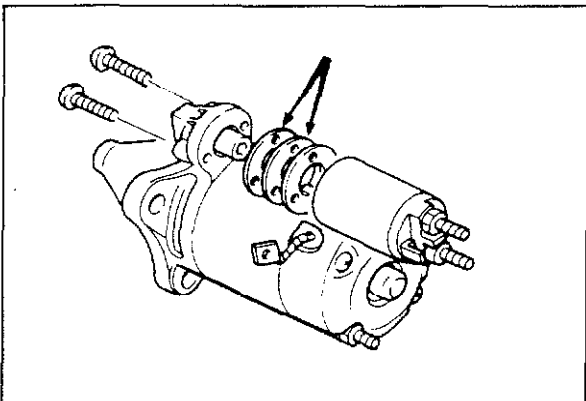

3. If the pinion gap is not within the specified range, make adjustment by increasing or decreasing the number of washers between the magnetic switch and the drive housing. The gap will become smaller if the number of washers is increased.

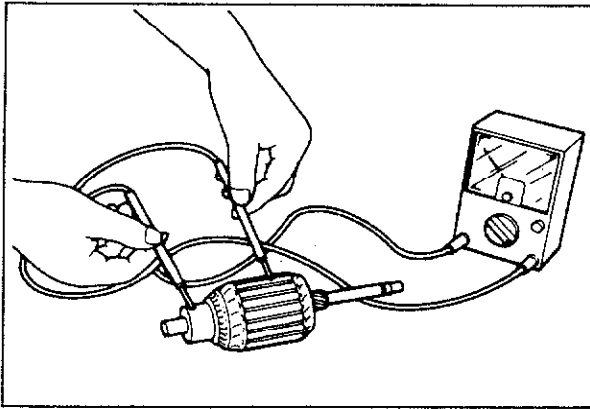

5BU05X-012

## INSPECTION

### Armature coil

1. Ground of the armature coil  
Check for continuity between the commutator and the core by using a circuit tester. Replace the armature if there is continuity.

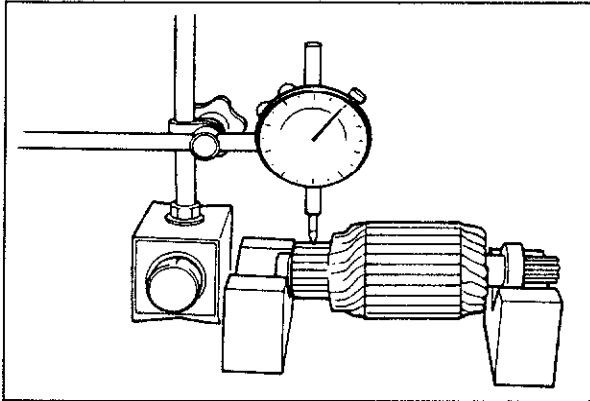

63U05X-023

2. Runout of the commutator  
Place the armature on V blocks, and measure the runout by using a dial gauge. If the runout is **0.05 mm (0.002 in)** or more, repair it by using a lathe, or replace the armature.

### Note

**Before checking, be sure that there is no play in the bearings.**

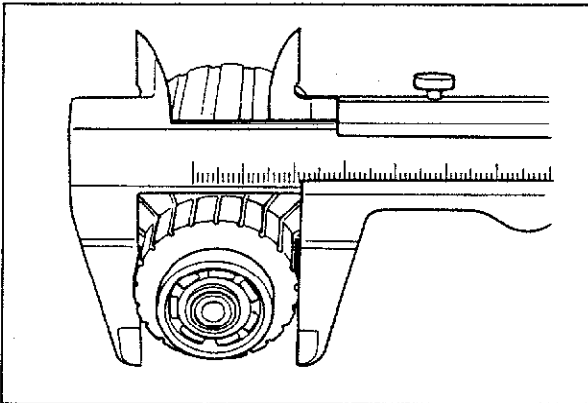

83U05X-013

3. Outer diameter of the commutator  
Replace the armature if the outer diameter of the commutator is **31 mm (1.22 in)** or less.
4. Roughness of the commutator surface  
If the commutator surface is dirty, wipe it with a cloth; if it is rough, repair it by using a lathe or fine sandpaper.

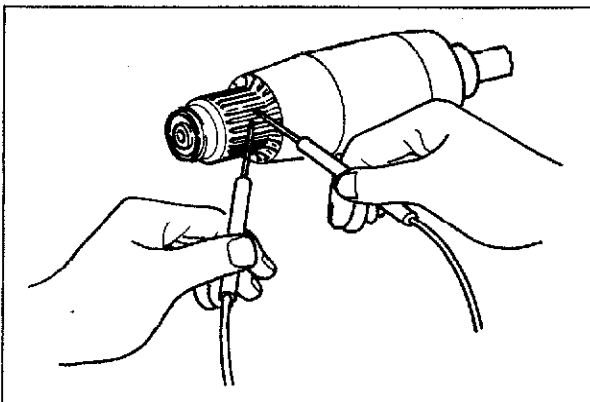

83U05X-014

5. Open circuit of the segment check for continuity between each segment of the commutator.  
If an open circuit exists between any segment, replace the armature.

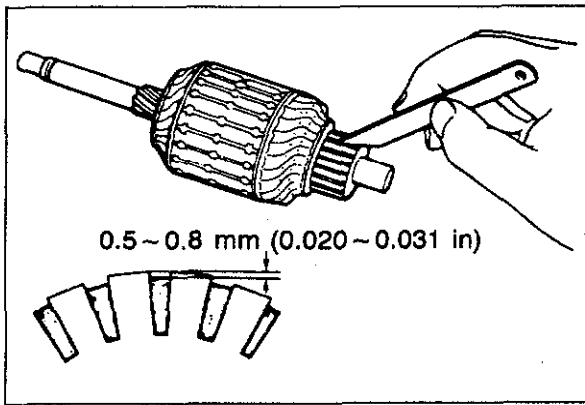

83U05X-015

## 6. Segments

If the depth of the mold between segments is **0.2 mm (0.008 in)** or less, undercut by **0.5 — 0.8 mm (0.020 — 0.031 in)**.

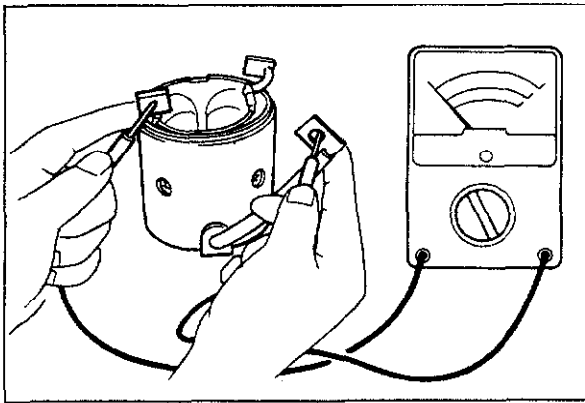

5BU05X-016

## Field coil

### 1. Wiring damage

Check for continuity between the connector and brushes by using a circuit tester. Replace the yoke assembly if there is no continuity.

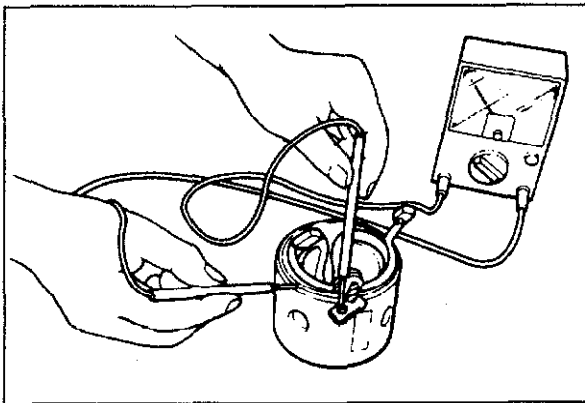

5BU05X-017

### 2. Ground of the field coil

Check for continuity between the connector and yoke by using a circuit tester. Repair, or replace the yoke assembly if there is continuity.

### 3. Installation of the field coil

Replace the yoke assembly if the field coil is loose.

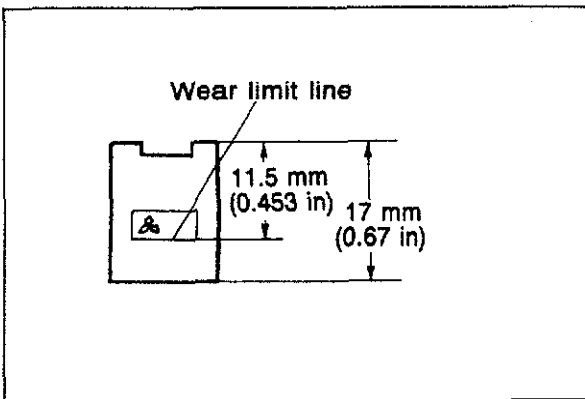

5BU05X-018

## Brush and brush holder

### 1. Brush

If the brushes are worn beyond the wear limit, or if the wear is near the limit, replace the brushes.

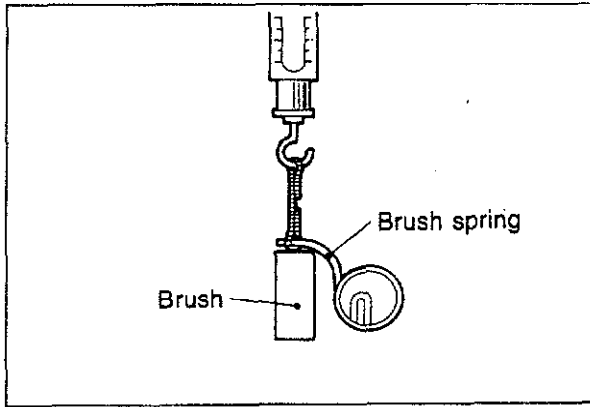

5BU05X-019

2. Brush spring  
Measure the force of the brush spring by using a spring balance. Replace the brush spring if the force is **9 N (900g, 31.75 oz)** or less.

**Note**

- a) The force is to be measured at the moment the brush spring separates from the brush.
- b) The force must be **14—25 N (1.4—2.6 kg, 3.1 lb—5.7 lb)** for a new brush.

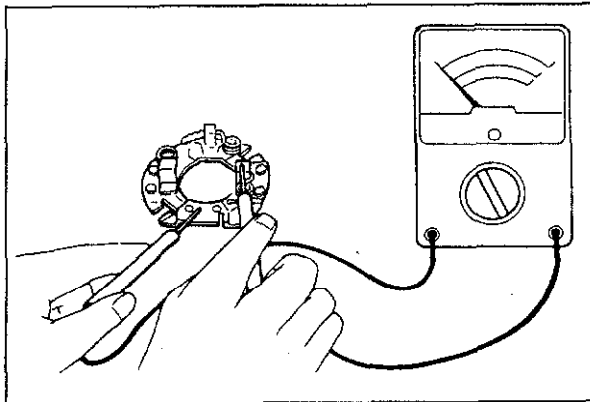

5BU05X-020

3. Brush holder  
Check for continuity between the insulated brush and the plate by using a circuit tester. Repair or replace if there is continuity.  
Also check that the brush slides smoothly inside the brush holder.

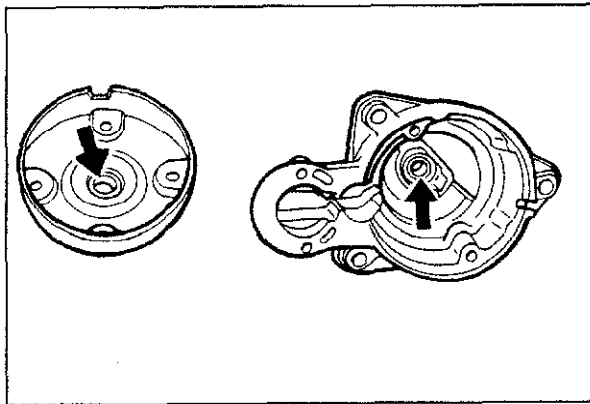

5BU05X-021

**Drive pinion and housing**

1. Pinion gear  
Check for wear or damage of the pinion gear. Replace if necessary.  
If the pinion gear is seriously damaged, also check the flywheel ring gear.
2. Bushing  
Check for wear or damage.  
Replace if necessary

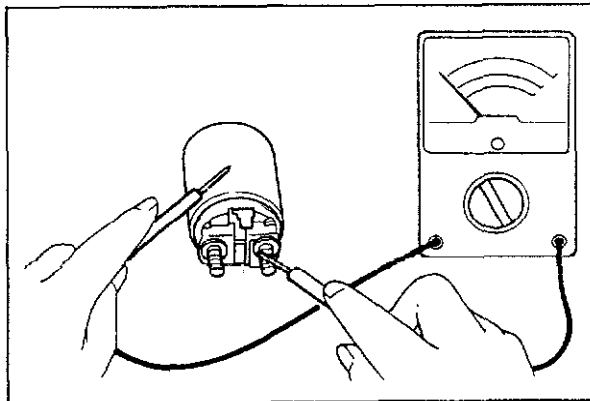

5BU05X-022

3. Switch coil  
Check for continuity between the M terminal and the body by using a circuit tester. Replace the switch if there is no continuity.



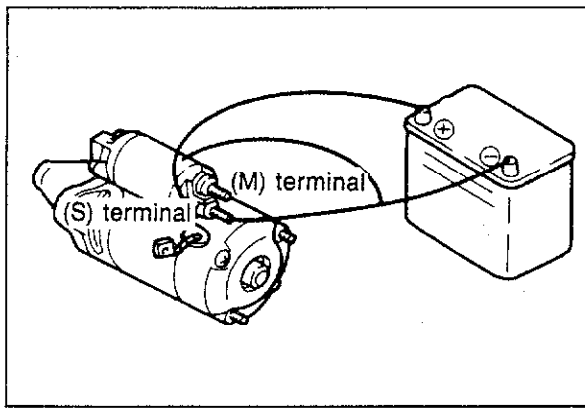

5BU05X-023

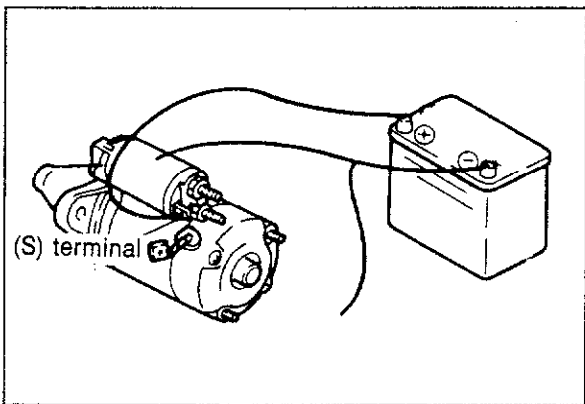

5BU05X-024

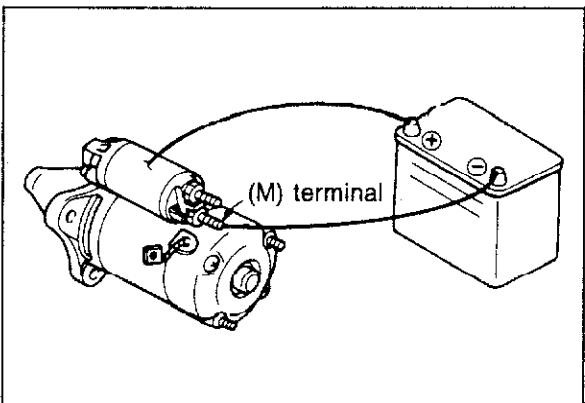

5BU05X-025

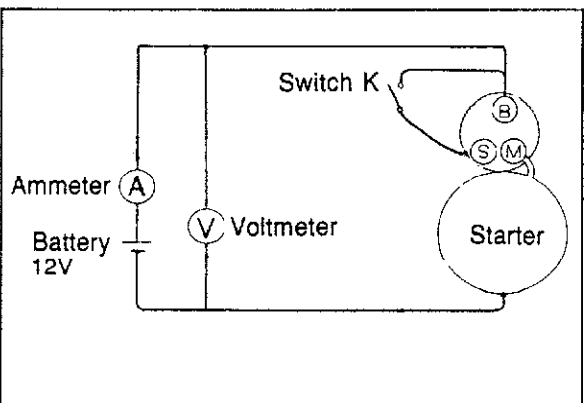

63U05X-024

## CHECKING OPERATION

### Magnetic switch

Disconnect the terminal M wire, and make the following tests.

### Pull-in test

The switch is normal if the pinion ejects outward when the battery is connected as shown in the figure at the left.

### Note

**Be careful not to apply power continuously for more than 10 seconds.**

### Hold-in test

After completing the pull-in test, disconnect the wire from terminal M (with the pinion left ejected). The hold-in coil is functioning properly if the pinion does not return.

### Return test

1. Connect the battery between terminal M of the magnetic switch and the body, as shown in the figure.
2. Pull the pinion out manually to the pinion stopper position.
3. The pinion should immediately return to its original position when it is released.

### No-load test

1. After adjusting the pinion gap, form a test circuit with a voltmeter and an ammeter.

### Note

**Use heavy cables or wiring to starter and tighten each terminal fully.**

2. Close switch "K" to run the starter at about 6500 rpm (gear shaft rpm). If the voltmeter and ammeter show the following values while the starter is running, it is normal.

**Battery voltage: 11.5 volts**

**Current: 60 amperes or less**

3. If any abnormality is noted, follow "INSPECTION" procedures to check starter.

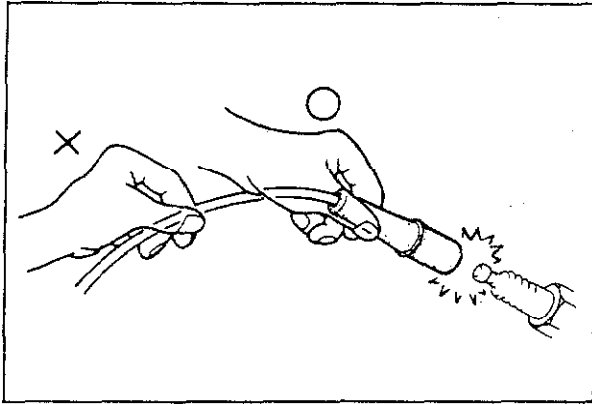

58U05X-027

## SPARK PLUGS

### REMOVAL AND INSTALLATION

Note the following points:

1. When the spark plug lead is to be pulled off, be sure to pull the boot itself, and not the wire.
2. Tighten the spark plugs to the specified torque.

### Spark plug tightening torque:

**14—23 N·m**

**(1.5—2.3 m·kg, 10.8—16.6 ft·lb)**

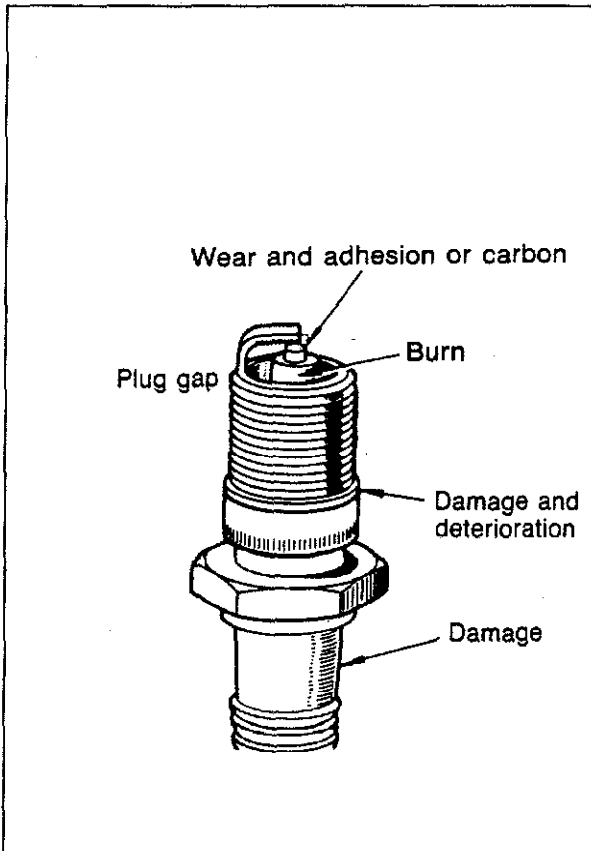

83U05X-028

### INSPECTION

Check the following points. If a problem is found, replace the spark plug.

1. Damaged insulation
2. Worn electrodes
3. Carbon deposits

If cleaning is necessary, use a plug cleaner or a wire brush. Clean the upper insulator also.

4. Damaged gasket
5. Burnt spark insulator

If it is black with carbon deposits, either misfiring due to improper proportions of gas and air, or overheating of the plug may have occurred.

**Plug gap: 1.0—1.1 mm (0.039—0.043 in)**

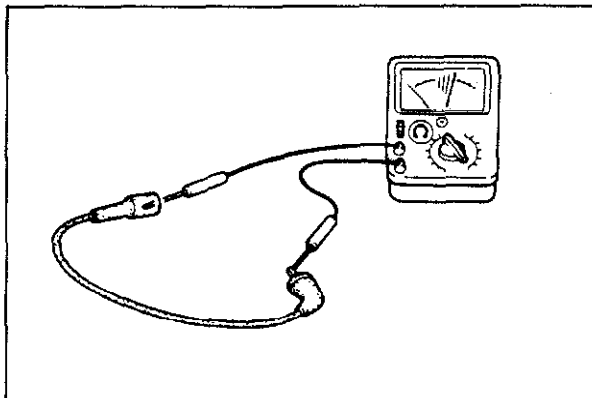

63U05X-026

## HIGH-TENSION LEADS

### INSPECTION

Use an ohmmeter to measure the resistance.

**Resistance: 16 kΩ per 1m (3.28 ft)**

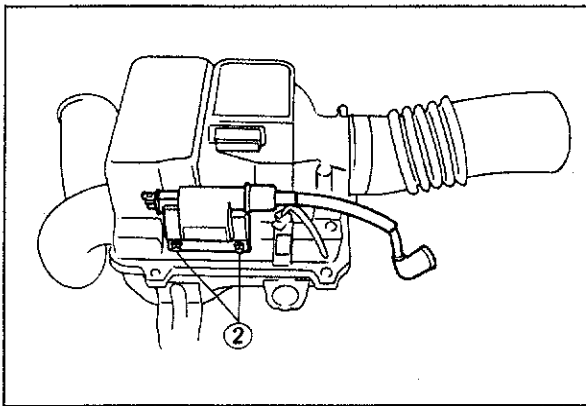

63U05X-013

## IGNITION COIL

### REMOVAL AND INSTALLATION

1. Disconnect the distributor lead and wires.
2. Remove the two installation bolts.
3. Install in the reverse order of removal.

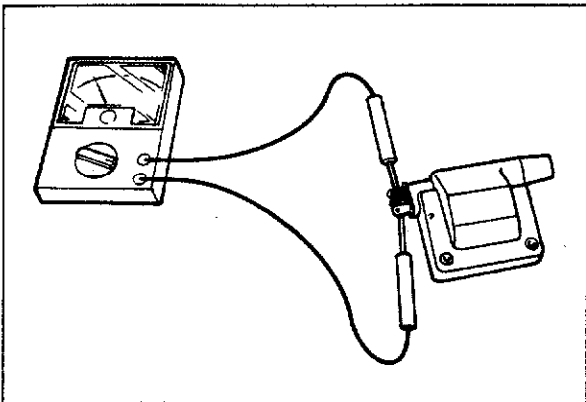

63U05X-027

### INSPECTION

#### Primary coil

Use a ohmmeter and check for continuity in the primary coil. If there is no continuity, replace the coil.

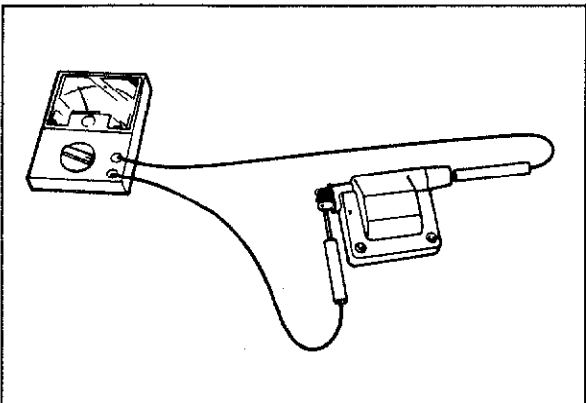

5BU05X-032

#### Secondary coil

Use a tester to measure the resistance of the secondary coil.

**Secondary coil resistance: 6—30 k $\Omega$**

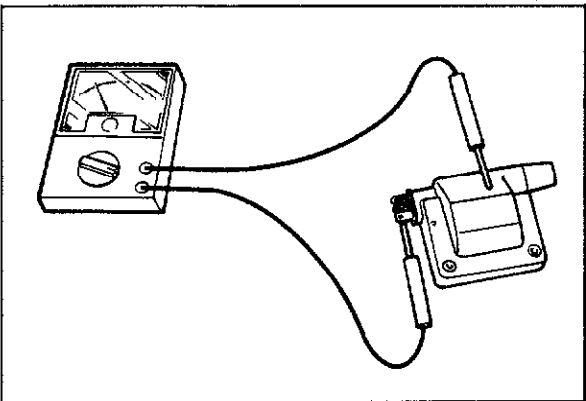

63U05X-028

#### Insulation of case

Use a 500V megger tester to measure the insulation resistance between the primary terminal and the case. The standard reading is **10 M $\Omega$  or more.**

#### Note

**The conventional type of ignition coil (for carburetor) is inspected the same as above.**

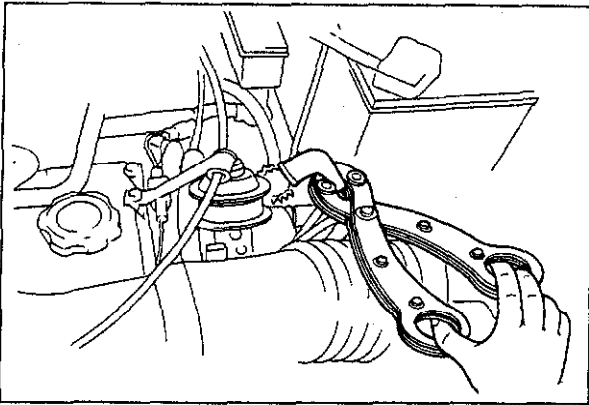

83U05X-016

**DISTRIBUTOR (NON-TURBO)****SPARK TEST**

1. Disconnect the distributor lead from distributor.
2. Hold it with insulated pliers and **5—10 mm (0.20—0.39 in)** from a ground.
3. Crank the engine and make sure a strong blue spark is visible.
4. If there is no spark, the ignition coil or pick-up coil may be bad.  
Check once again after replacing the ignition coil or pick-up coil.

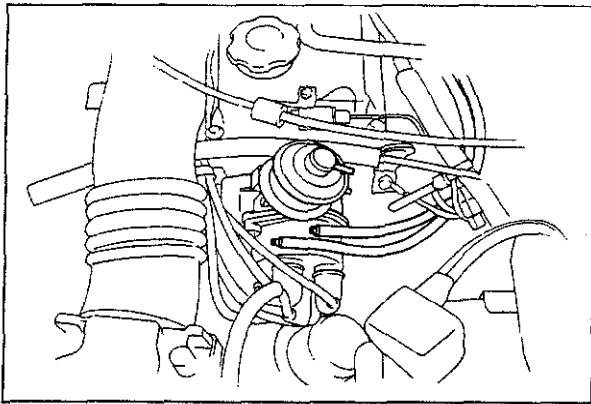

83U05X-017

**IGNITION TIMING (NON-TURBO)**

1. Warm up the engine to the normal operating temperature.
2. Turn all electric loads OFF.
3. Disconnect the vacuum hoses from the vacuum control and plug them.
4. Connect a tachometer and check the idle speed. Set to specified speed if necessary.

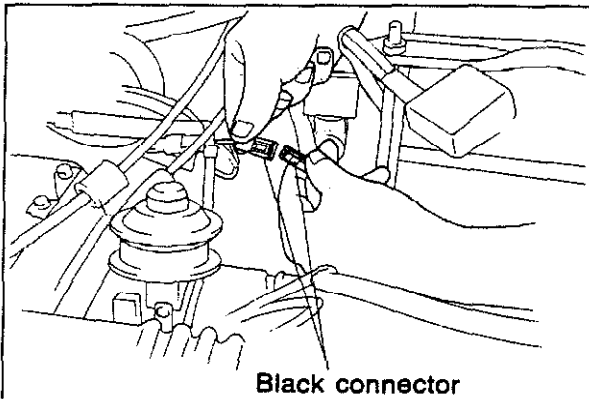
**Idle speed:****850 ± 50 rpm****Black connector**

63U05X-034

5. Disconnect the black connector at the distributor.
6. Connect a timing light.

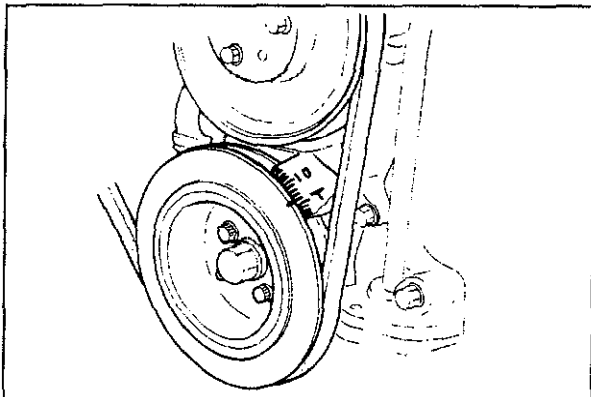

63U05X-035

7. With the timing light, check the ignition timing.

**Initial ignition timing: 2 ± 1° BTDC**

## 5 DISTRIBUTOR (NON-TURBO)

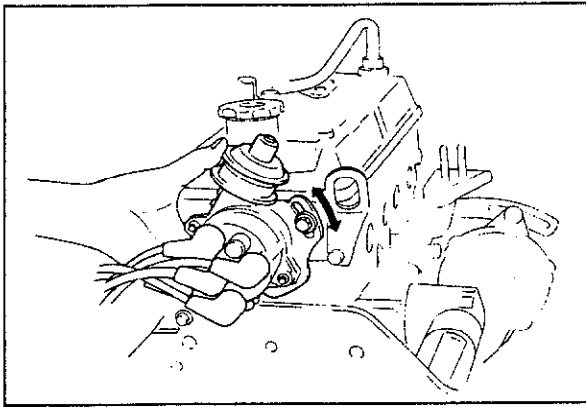

63U05X-036

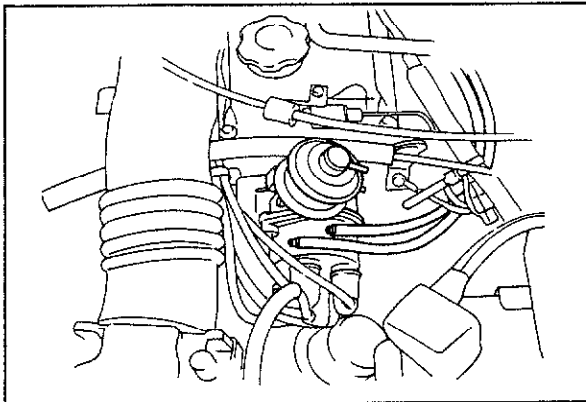

83U05X-018

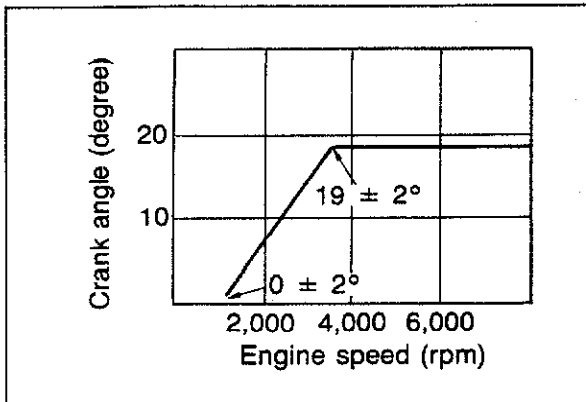

5BU05X-039

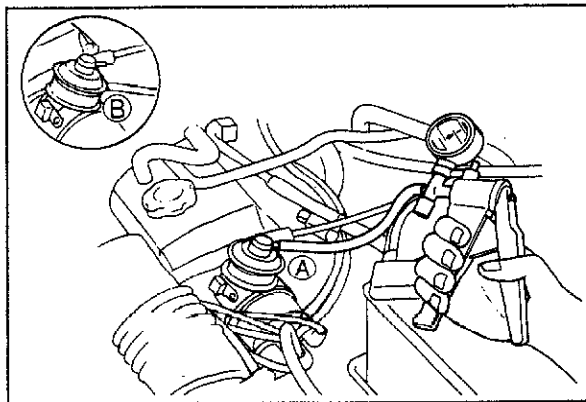

4BG05X-041

- If the ignition timing is not within specification, loosen the distributor body installation bolts and adjust the ignition timing by turning the body.
- Reconnect the vacuum hoses to the vacuum control and check the ignition timing.

**Ignition timing: approx. 7° BTDC**

- Reconnect the black connector.

### SPARK ADVANCE CONTROL

#### Centrifugal

- Warm up the engine to operating temperature.
- Check that the idle speed and ignition timing are correct.
- Disconnect the vacuum hoses from the vacuum control, and plug the ends of the hoses.

- While gradually increasing the engine speed, use a timing light to check the advance angle on the pulley.

Excess advance..... weak governor spring  
(if the governor spring is broken, the advance will rise very high)

Insufficient advance.. governor weight or cam malfunction

#### Vacuum

- Warm up the engine to operating temperature.
- Check that the idle speed and ignition timing are correct.
- Disconnect the vacuum hoses from the vacuum control, and plug the ends of the hoses.
- Run the engine at idle.
- Attach a vacuum pump to the control (A, B) and check by using the timing light while applying vacuum.

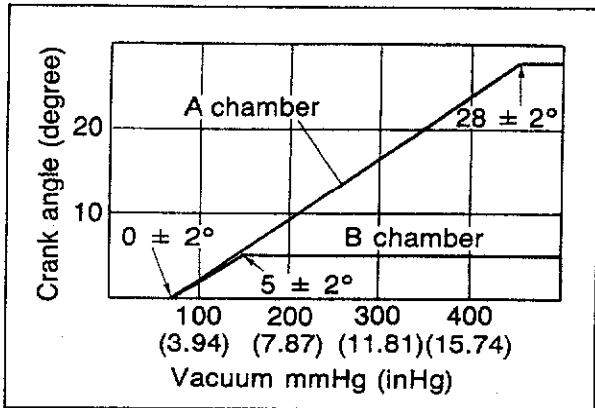

63U05X-999

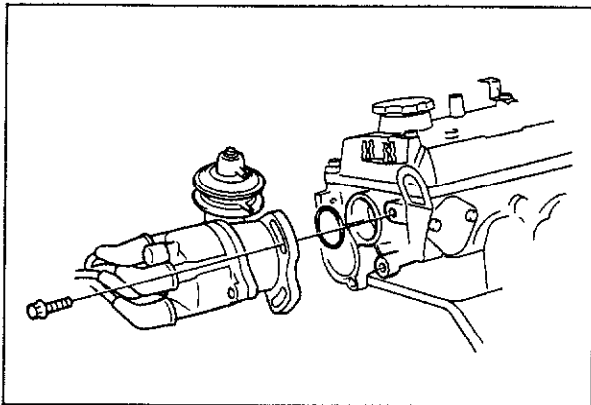

63U05X-042

## REMOVAL

1. Remove the high-tension leads.
2. Disconnect the vacuum hose and wiring.
3. Turn the crankshaft so that No. 1 cylinder is at top dead center of compression.
4. Remove the distributor.

### Note

**Do not turn the crankshaft after the distributor has been removed.**

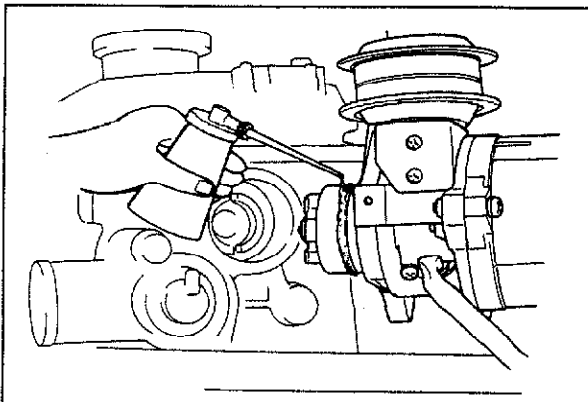

63U05X-043

## INSTALLATION

Install in the reverse order of removal.

Note the following points:

1. Coat the O-ring with engine oil.
2. Check that the No. 1 cylinder is at top dead center.

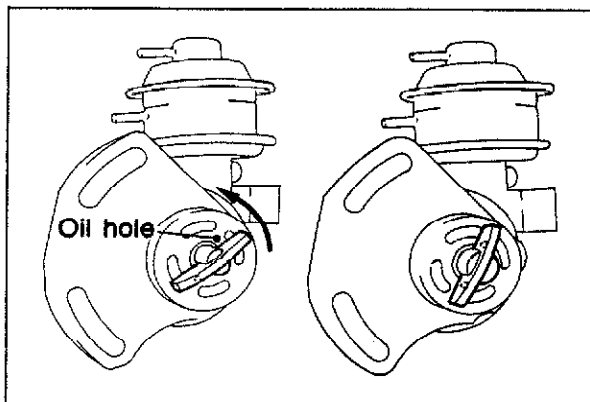

63U05X-044

3. Align the distributor blade with the small oil holes, then install the distributor.
4. Adjust the ignition timing after installation.

# 5 DISTRIBUTOR (NON-TURBO)

## DISASSEMBLY AND ASSEMBLY

1. Disassemble in the numbered order shown in the figure.
2. Assemble in the reverse order of disassembly.

63U05X-045

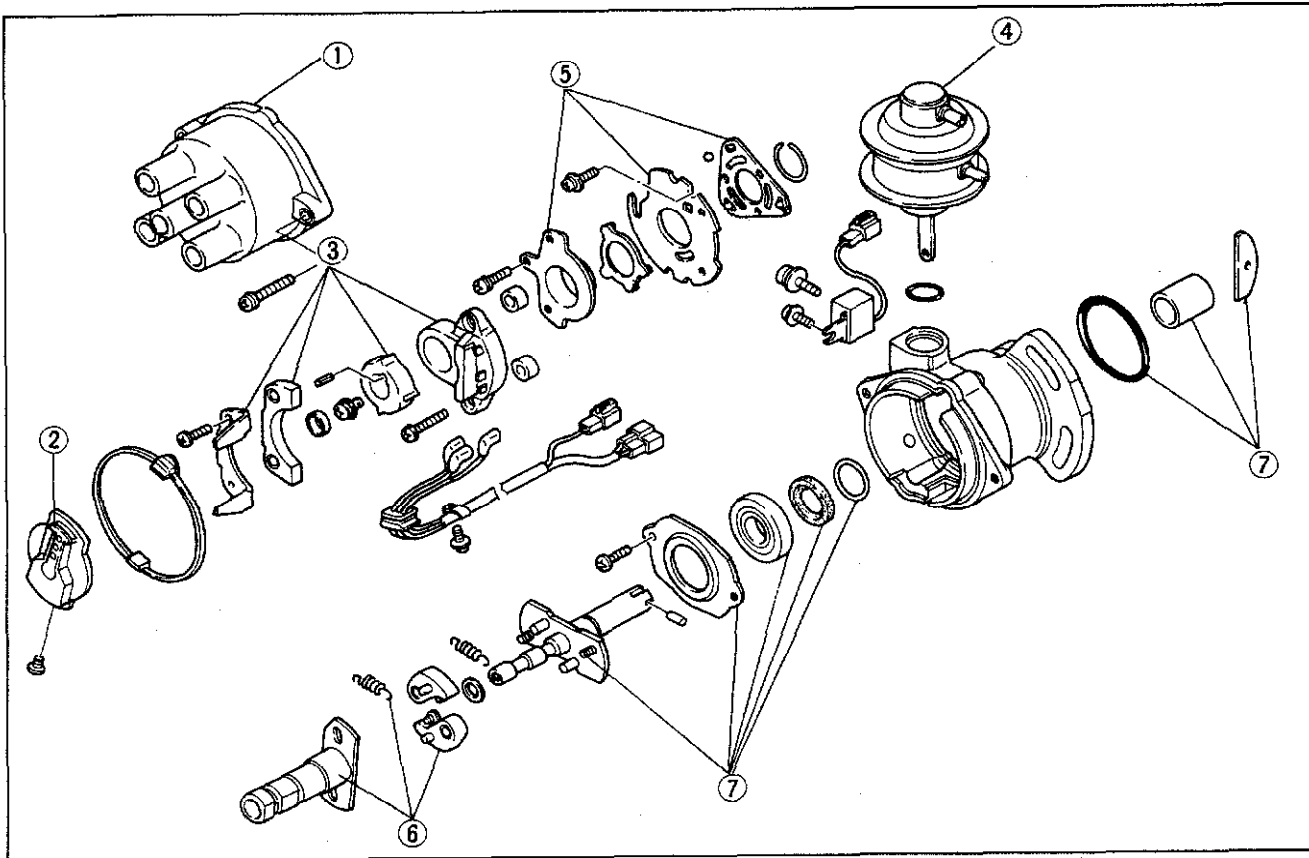

63U05X-046

1. Cap
2. Rotor
3. Pick-up set
4. Vacuum control unit

5. Breaker plate assembly
6. Governor set
7. Shaft assembly

H.E.I. TROUBLESHOOTING

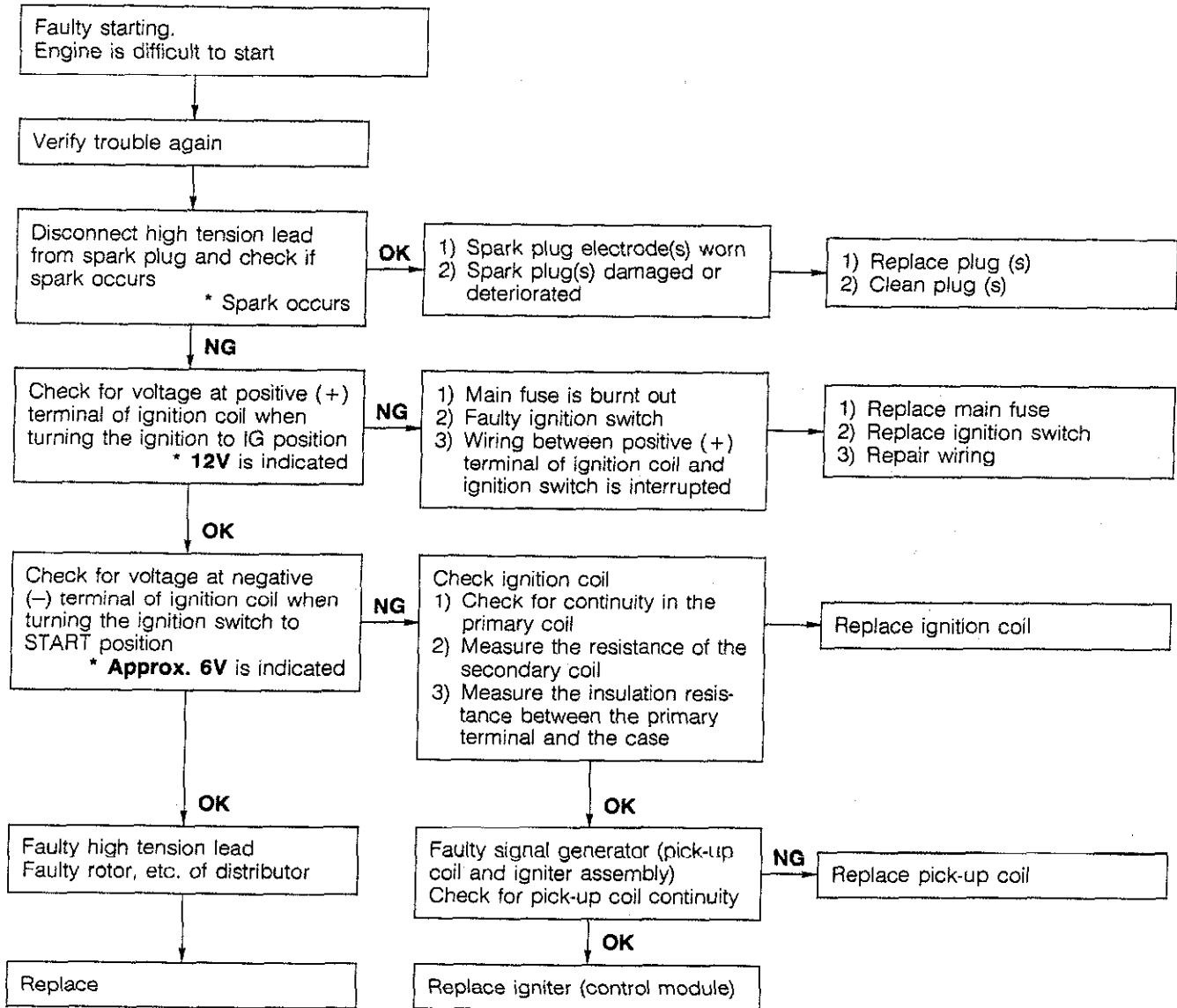

83U05X-029



## 5 DISTRIBUTOR (TURBO)

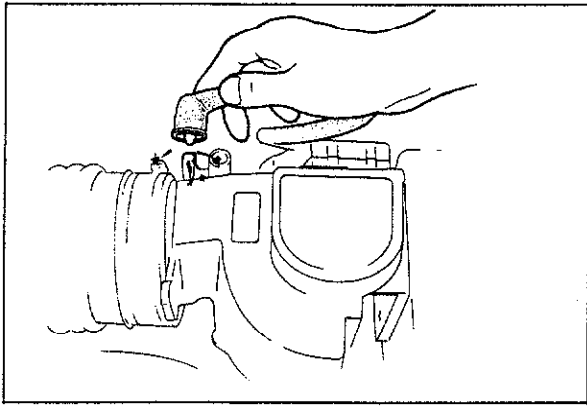

83U05X-019

### DISTRIBUTOR (TURBO)

#### SPARK TEST

1. Disconnect the distributor lead from the distributor.
2. Hold the lead approx. **5—10 mm (0.20—0.39 in)** from a ground.
3. Crank the engine and check for a strong blue spark.
4. If there is no spark, check the ignition coil and pick-up coil.

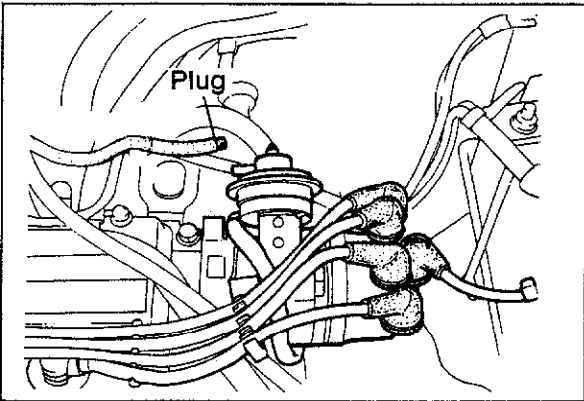

83U05X-020

#### IGNITION TIMING

1. Warm up the engine to operating temperature.
2. Turn all electric loads OFF.
3. Disconnect the vacuum hose from the vacuum control unit and plug the hose.
4. Connect a tachometer to the engine and check the idle speed.

**Idle speed: 850 ± 50 rpm**

5. Connect a timing light to the engine.

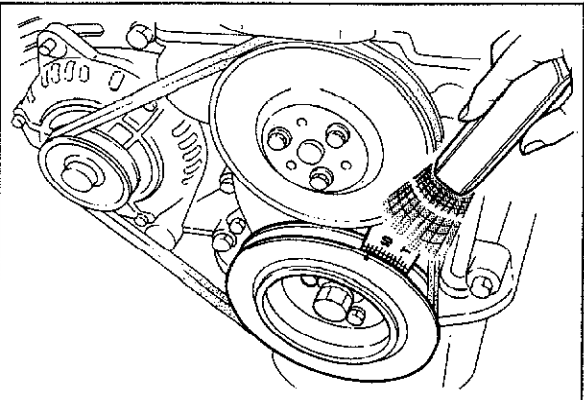

83U05X-030

6. Check the ignition timing.

**Initial ignition timing: 12 ± 1° BTDC**

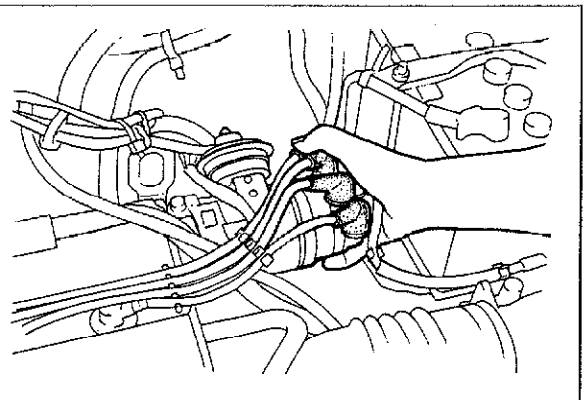

63G05X-349

7. If the ignition timing is not within specification, loosen the distributor body installation bolts and adjust.

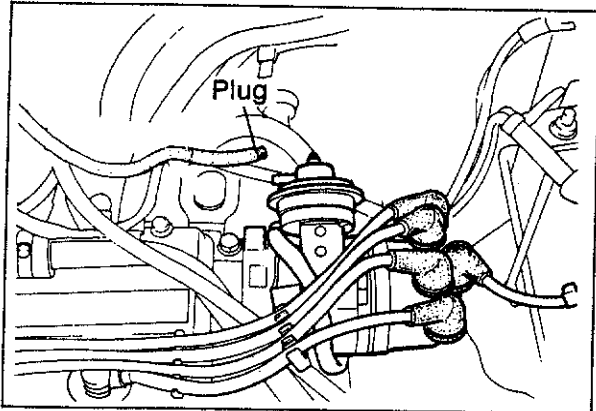

63G05X-350

## SPARK ADVANCE CONTROL

### Centrifugal

1. Warm up the engine to operating temperature.
2. Check that the idle speed and ignition timing are correct.
3. Disconnect the vacuum hose from the vacuum control unit, and plug the hose.

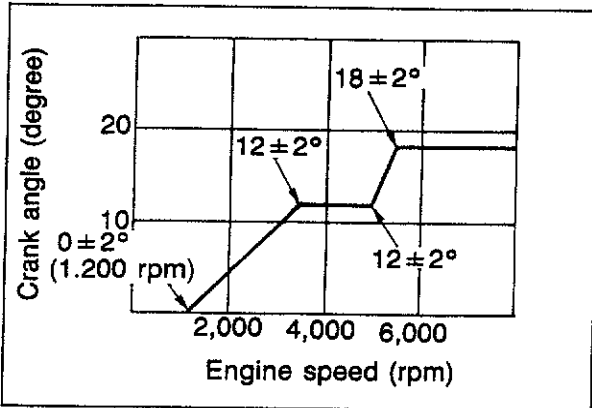

5BU05X-039

4. While gradually increasing the engine speed, use a timing light to check the timing advance.

Excess advance..... weak governor spring  
(if the governor spring is broken, the advance will rise very high)

Insufficient advance.. governor weight or cam malfunction

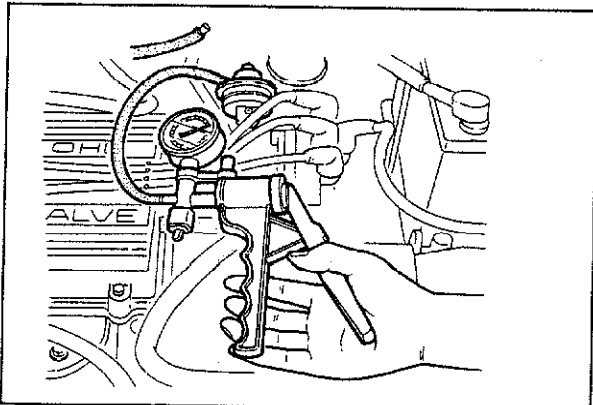

63G05X-351

### Vacuum

1. Warm up the engine to operating temperature.
2. Check that the idle speed and ignition timing are correct.
3. Disconnect the vacuum hose from the vacuum control unit, and plug the hose.
4. Connect a vacuum pump to the vacuum control unit and check by using the timing light while applying vacuum.

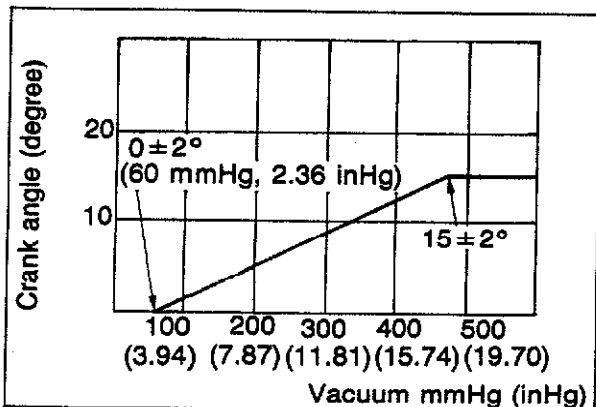

63G05X-352

# 5 DISTRIBUTOR (TURBO)

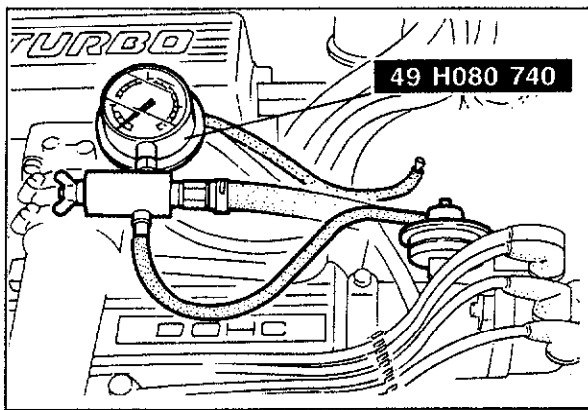

63G05X-353

## Positive Pressure (Boost)

1. Warm up the engine to operating temperature.
2. Check that the idle speed and ignition timing are correct.
3. Disconnect the vacuum hose from the vacuum control, and plug the hose.
4. Connect the **SST** to the vacuum control.
5. Apply compressed air gradually by turning the adjusting screw and check that the ignition timing retards.

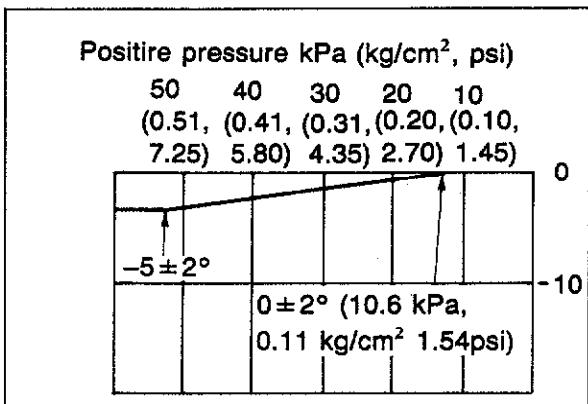

63G05X-352

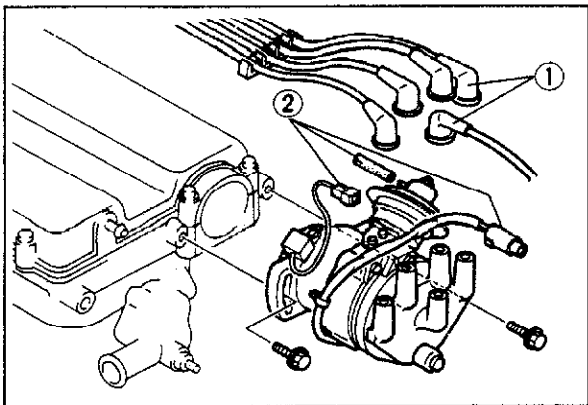

63U05X-042

## REMOVAL

1. Remove the high-tension leads.
2. Disconnect the vacuum hoses and wiring connectors.
3. Turn the crankshaft so that No. 1 cylinder is at top dead center of compression.
4. Remove the distributor.

## Note

**Do not turn the crankshaft after the distributor has been removed.**

## INSTALLATION

1. Coat the O-ring with engine oil.
2. Check that No. 1 cylinder is at top dead center.
3. Align the distributor blade with the grooved matching mark on the body, then install the distributor. Adjust the ignition timing after installation and tighten the retaining bolts.

63G05X-354

## DISASSEMBLY AND ASSEMBLY

1. Disassemble in the numbered order shown in the figure.
2. Assemble in the reverse order of disassembly.

63U05X-045

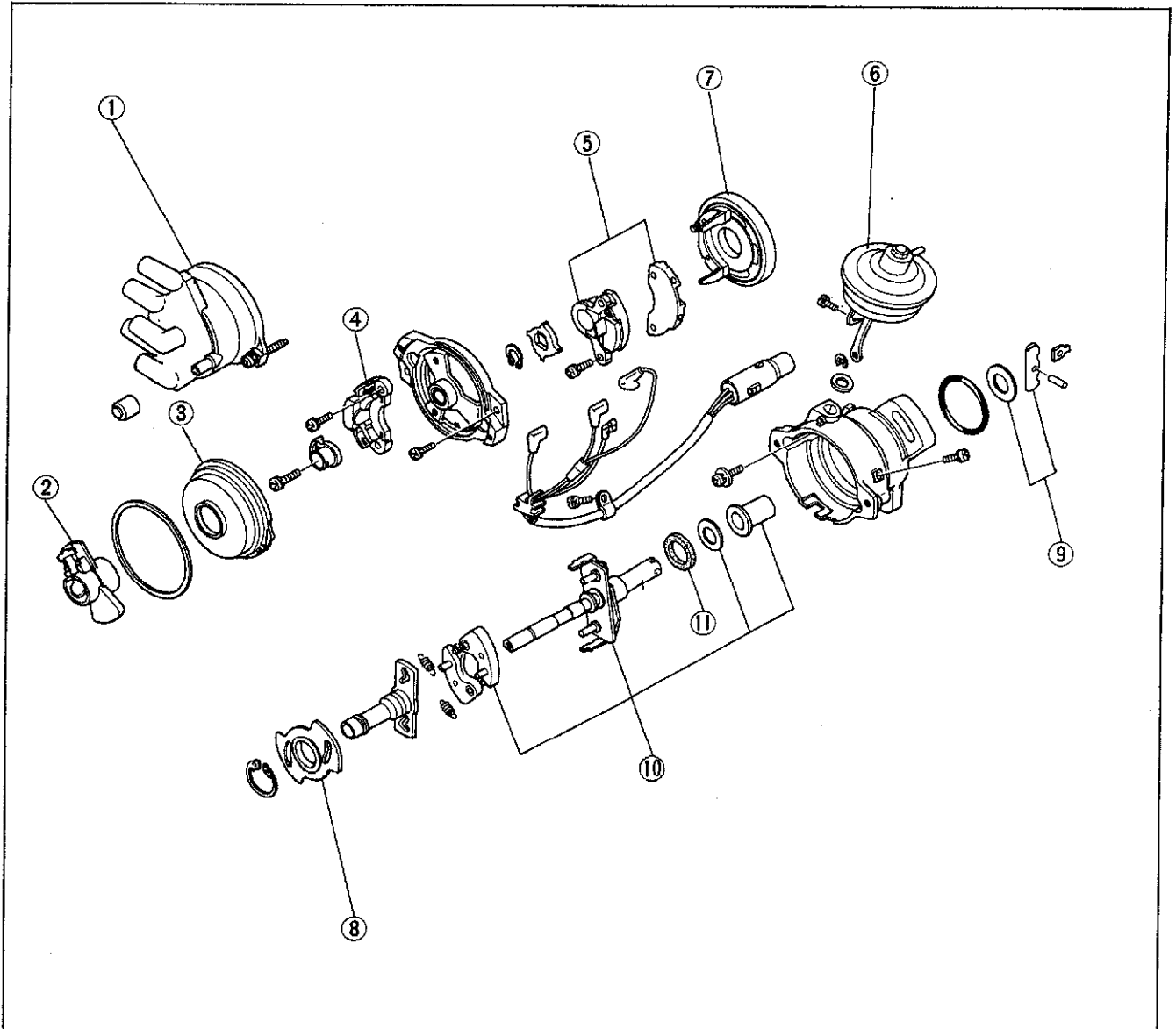

63G05X-355

- |                          |                             |                  |
|--------------------------|-----------------------------|------------------|
| 1. Cap                   | 5. Pick-up coil and igniter | 9. Coupling set  |
| 2. Rotor                 | 6. Vacuum control unit      | 10. Governor set |
| 3. Cover                 | 7. Breaker                  | 11. Oil seal     |
| 4. Signal rotor and unit | 8. Plate                    |                  |

# 5 DISTRIBUTOR (TURBO)

## H.E.I. TROUBLESHOOTING (TURBO)

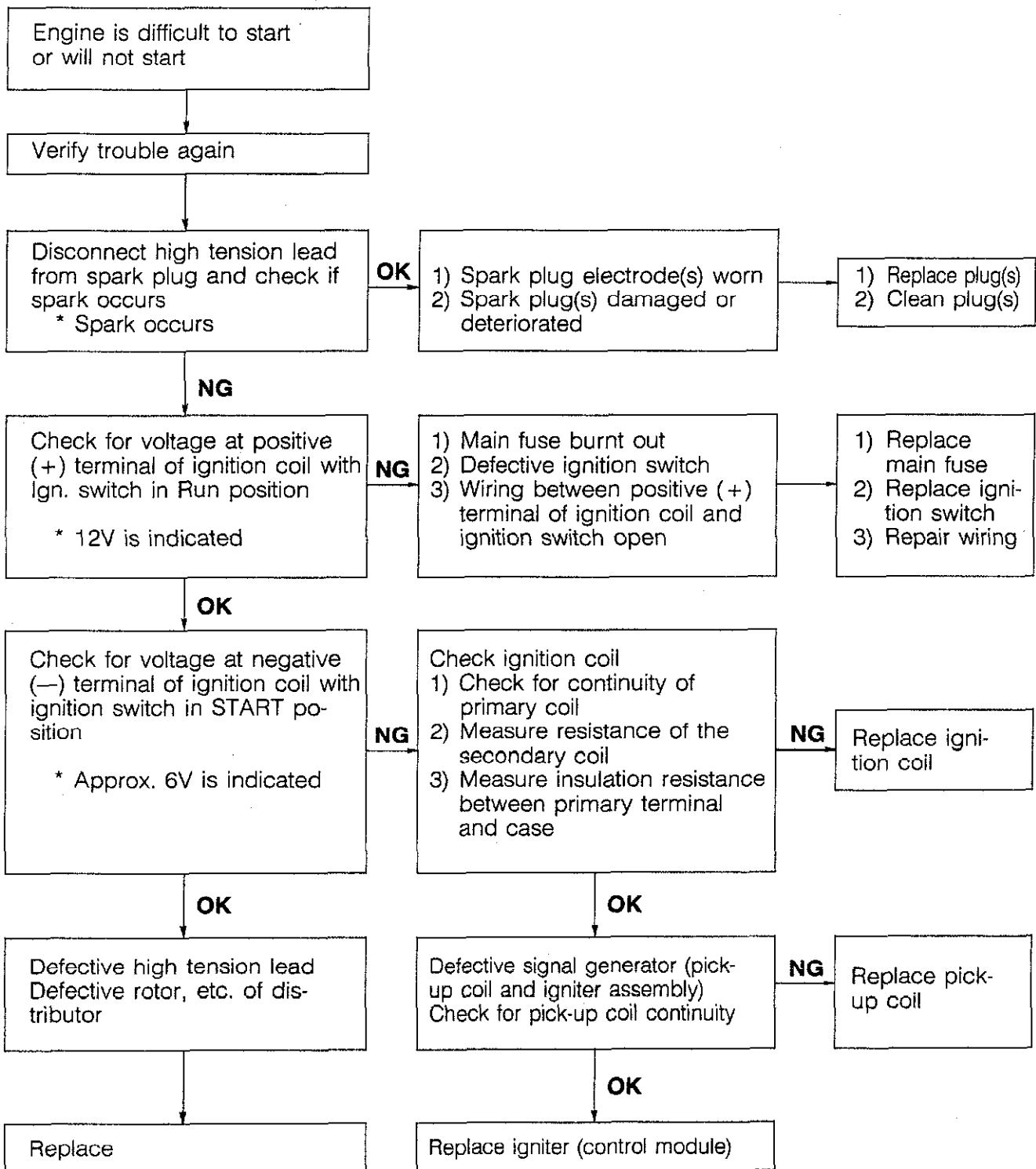

KNOCK CONTROL SYSTEM (TURBO)

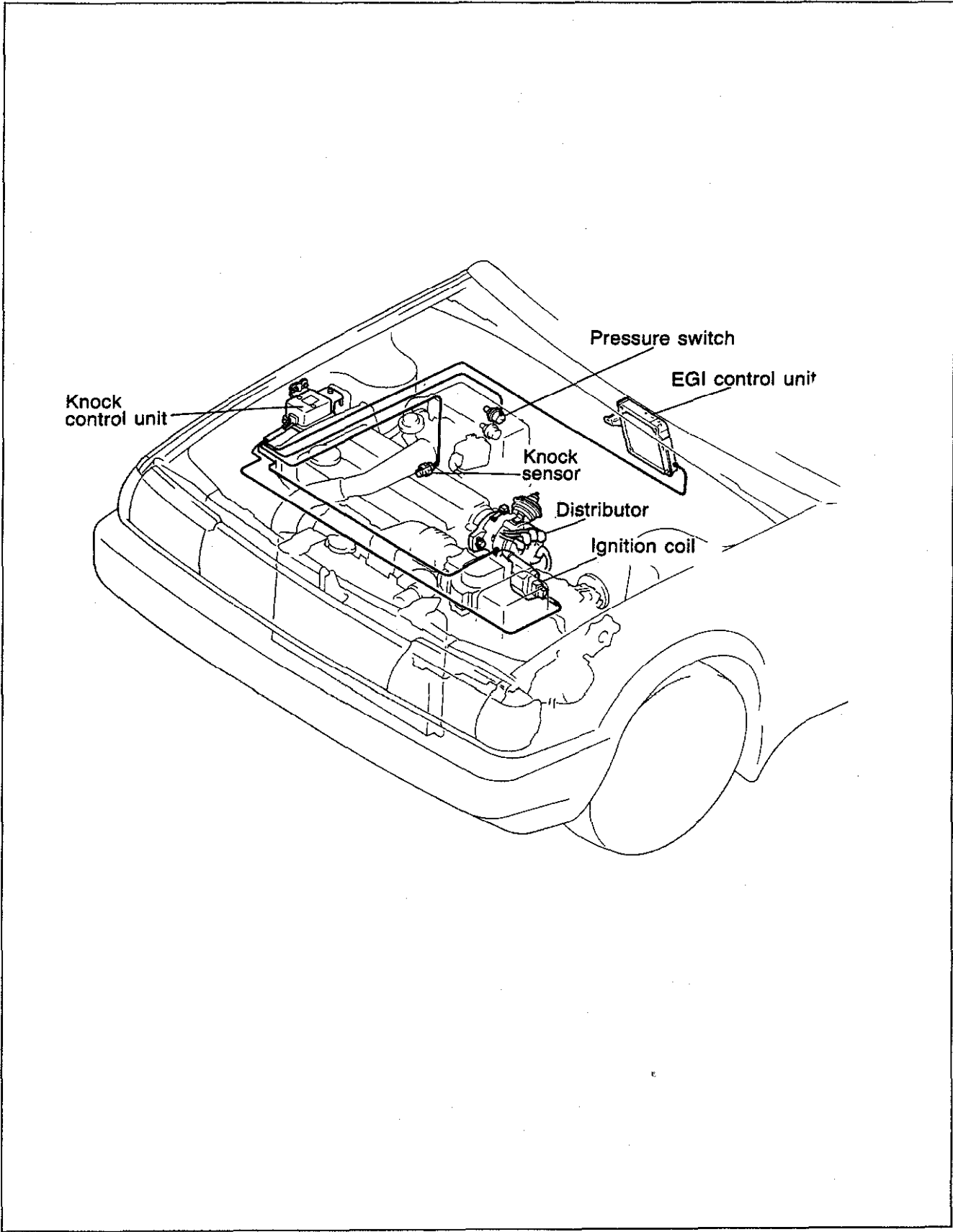

# 5 KNOCK CONTROL SYSTEM

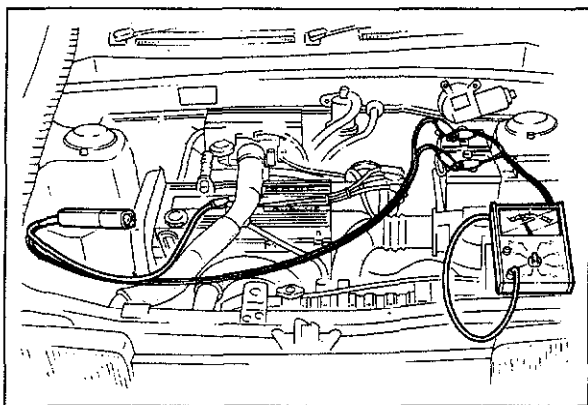

83U05X-032

## INSPECTION OF RETARD FUNCTION

1. Warm up the engine to operating temperature.
2. Connect a tachometer and a timing light to the engine.
3. Run at idle and check that the ignition timing is within specification.

**Specification:  $12 \pm 1^\circ$  BTDC**

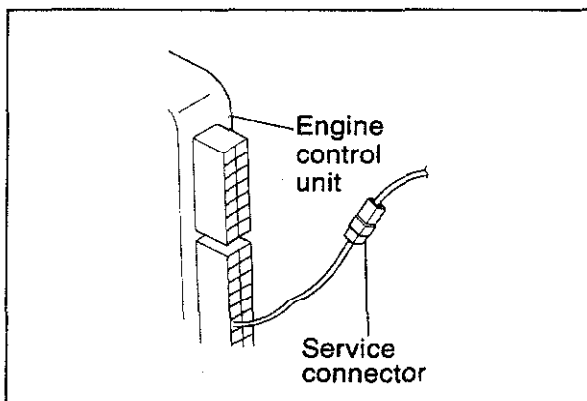

83U05X-022

4. Disconnect the service connector.

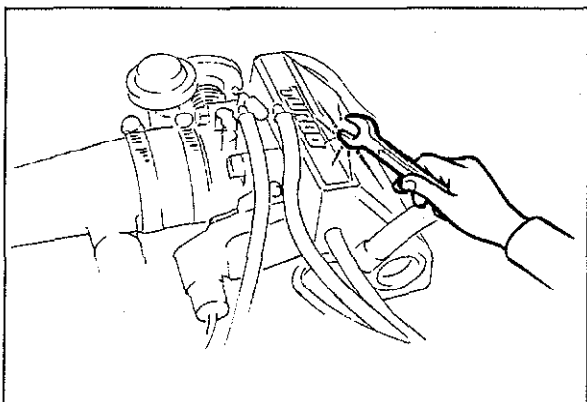

83U05X-033

5. Tap the intake manifold assembly with a wrench as shown in the figure, and check that the ignition timing retards.
6. Stop tapping the surge tank bracket and confirm that the ignition timing returns to specification.

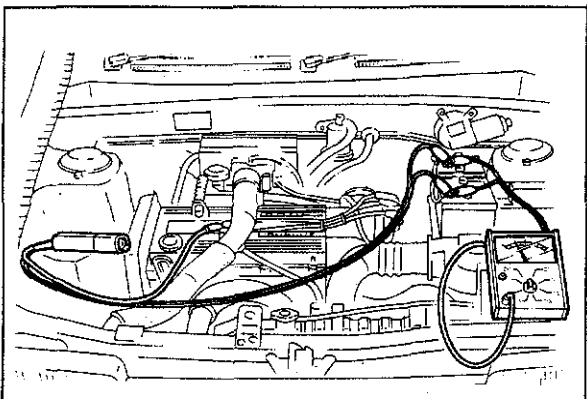

83U05X-034

## INSPECTION OF FAIL SAFE FUNCTION

1. Warm up the engine to operating temperature.
2. Attach a tachometer and a timing light to the engine.
3. Run at idle and check that the ignition timing is within specification.

**Specification:  $12 \pm 1^\circ$  BTDC**

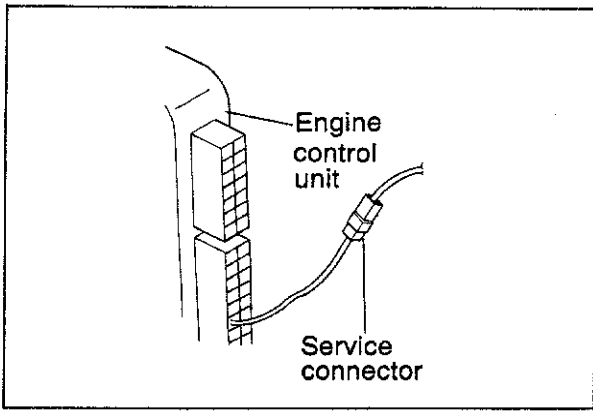

83U05X-035

4. Disconnect the service connector.

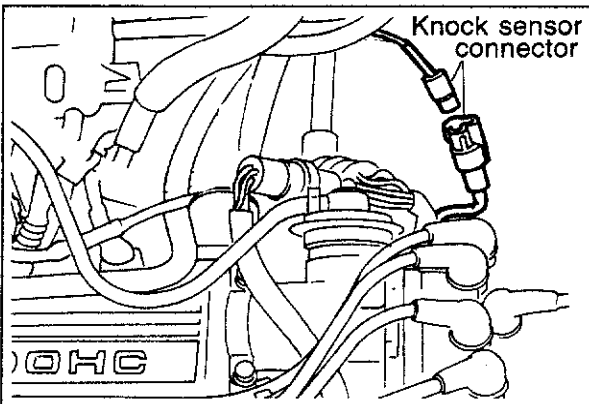

83U05X-036

5. Disconnect the knock sensor connector and check that the ignition timing retards.
6. Reconnect the knock sensor connector and confirm that the ignition timing returns to specification.

**Specification:  $12 \pm 1^\circ$  BTDC**

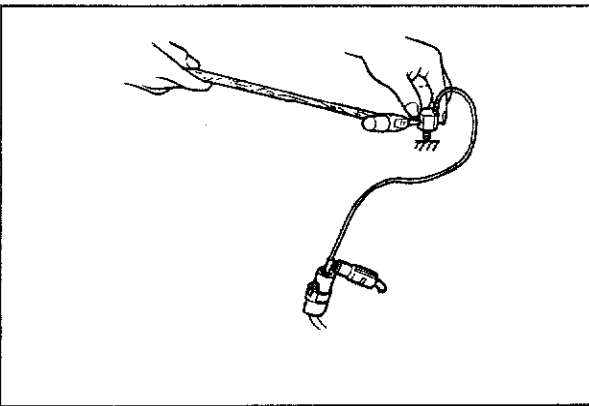

56U05X-088

### INSPECTION OF KNOCK SENSOR

1. Check the retard function.
2. If the ignition timing does not retard, go to next step.
3. Disconnect the knock sensor connector.
4. Connect a good knock sensor to the vehicle and ground the sensor.
5. Tap the sensor and make sure the ignition timing retards.
6. If the retard operates, replace the knock sensor.



# 5 KNOCK CONTROL SYSTEM

## TROUBLESHOOTING

This troubleshooting is made for devices concerning with the knock control system. Therefore, this troubleshooting should be performed after first checking the distributor (pick-up coil, spark advances, etc.), the ignition coil, the spark plugs, and the high-tension leads.

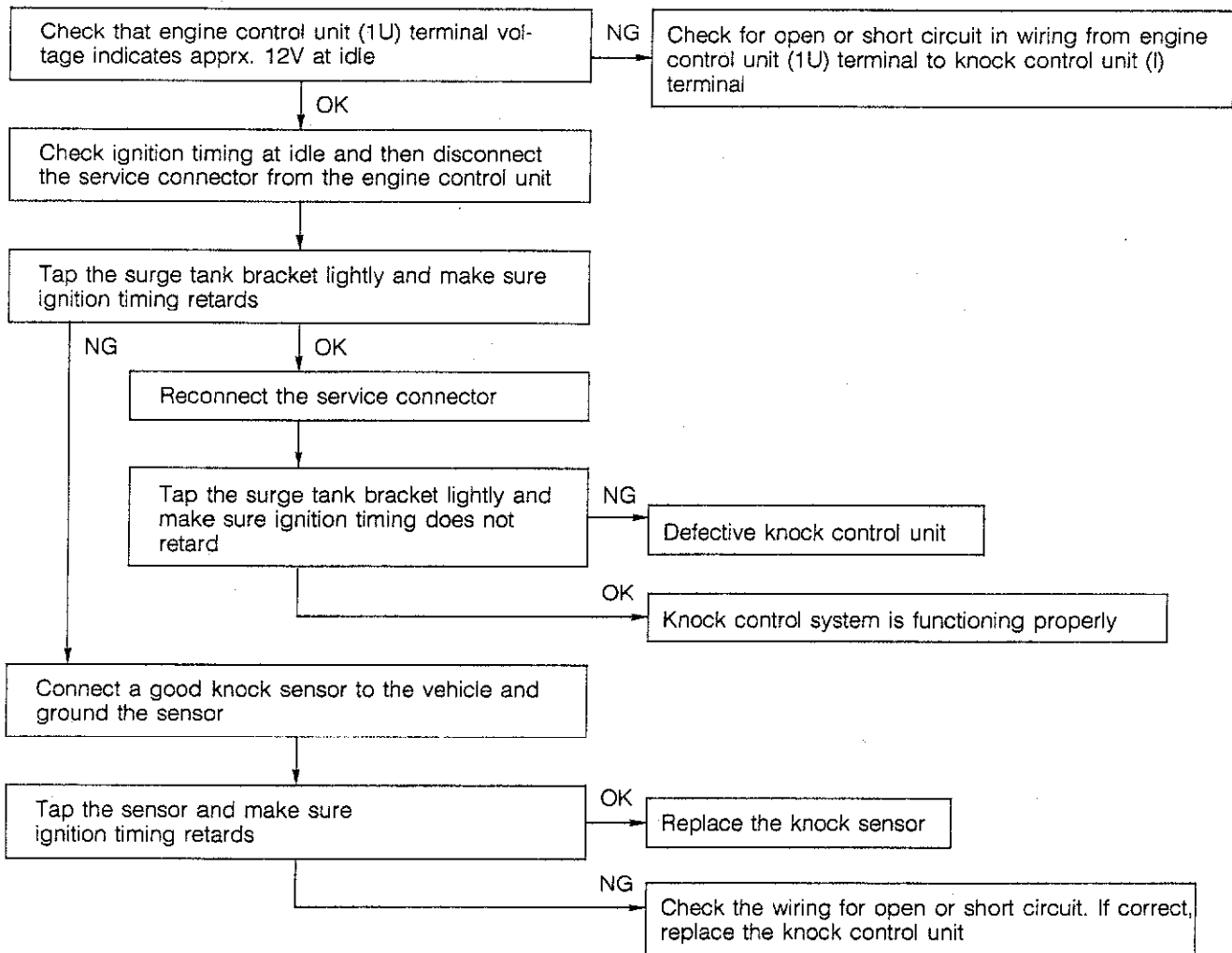

83U05X-037

# CLUTCH

## CABLE type

- OUTLINE** ..... 6— 2
- STRUCTURAL VIEW ..... 6— 2
- SPECIFICATIONS ..... 6— 4
- TROUBLESHOOTING GUIDE** ..... 6— 4
- ON-VEHICLE MAINTENANCE**..... 6— 5
- PEDAL HEIGHT..... 6— 5
- PEDAL FREEPLAY..... 6— 5
- CLUTCH PEDAL**..... 6— 6
- REMOVAL ..... 6— 6
- INSPECTION ..... 6— 6
- INSTALLATION..... 6— 7
- CLUTCH CABLE**..... 6— 8
- REMOVAL ..... 6— 8
- INSPECTION ..... 6— 8
- INSTALLATION..... 6— 8
- CLUTCH AND FLYWHEEL**..... 6—17
- REMOVAL ..... 6—17
- INSPECTION ..... 6—18
- INSTALLATION..... 6—20

## HYDRAULIC type

- OUTLINE** ..... 6— 3
- STRUCTURAL VIEW..... 6— 3
- SPECIFICATIONS..... 6— 4
- TROUBLESHOOTING GUIDE** ..... 6— 4
- ON-VEHICLE MAINTENANCE**..... 6— 9
- INSPECTION AND ADJUSTMENT**..... 6— 9
- CLUTCH PEDAL HEIGHT ..... 6— 9
- CLUTCH PEDAL PLAY ..... 6— 9
- CLUTCH PEDAL**..... 6—10
- REMOVAL AND INSTALLATION..... 6—10
- INSPECTION..... 6—10
- MASTER CYLINDER** ..... 6—11
- REMOVAL AND INSTALLATION..... 6—11
- DISASSEMBLY AND ASSEMBLY ..... 6—12
- INSPECTION..... 6—14
- ASSEMBLY..... 6—14
- RELEASE CYLINDER**..... 6—15
- REMOVAL AND INSTALLATION..... 6—15
- DISASSEMBLY, INSPECTION AND  
  ASSEMBLY ..... 6—16
- CLUTCH AND FLYWHEEL**..... 6—17
- REMOVAL ..... 6—17
- INSPECTION..... 6—18
- INSTALLATION..... 6—20

## OUTLINE

### STRUCTURAL VIEW 2WD

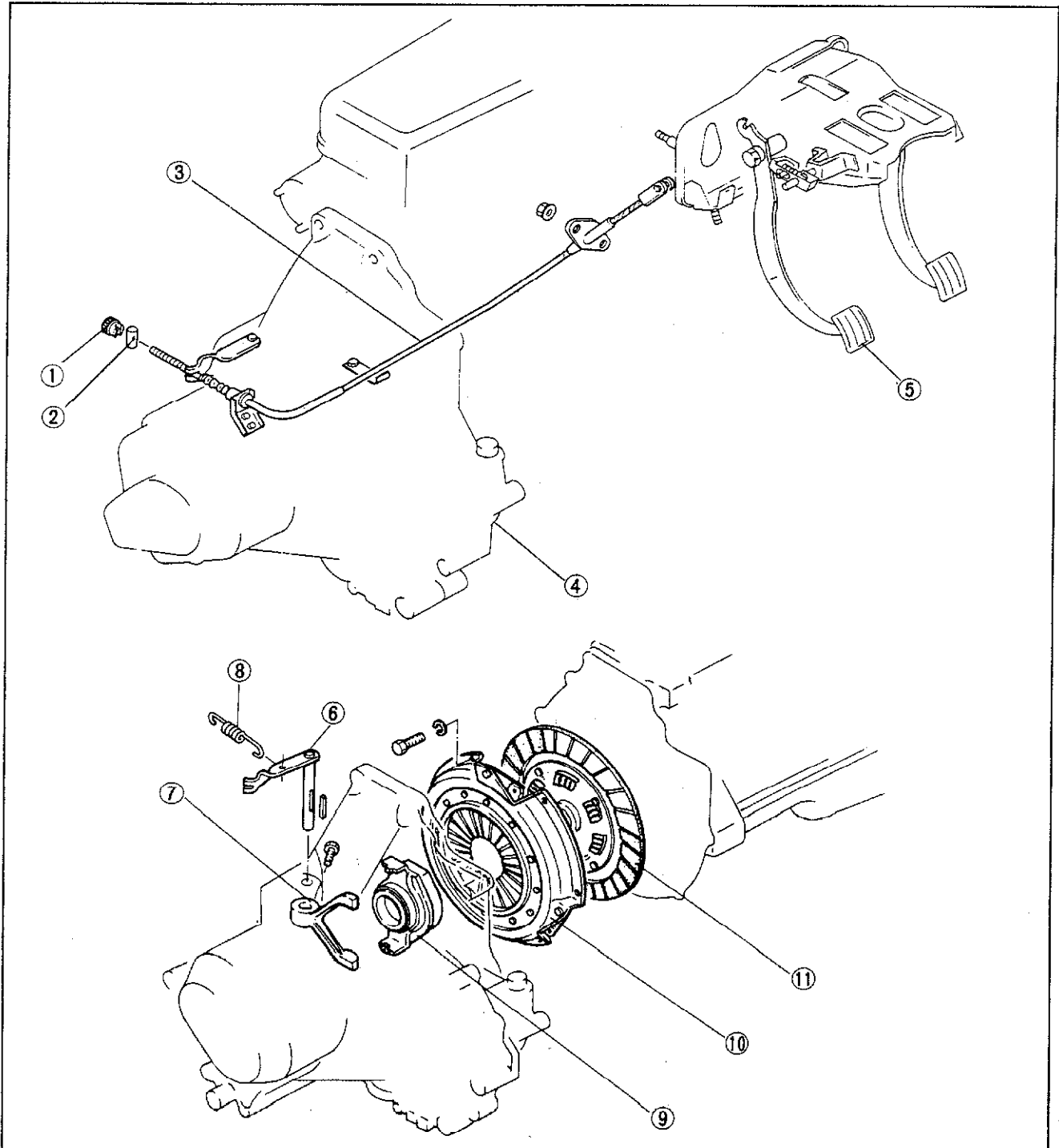

83U06X-002

- 1. Adjusting nut
- 2. Pin
- 3. Clutch cable
- 4. Transaxle
- 5. Clutch pedal
- 6. Release lever

- 7. Release fork
- 8. Return spring
- 9. Release bearing
- 10. Clutch cover
- 11. Clutch disc

OUTLINE

STRUCTURAL VIEW  
4WD

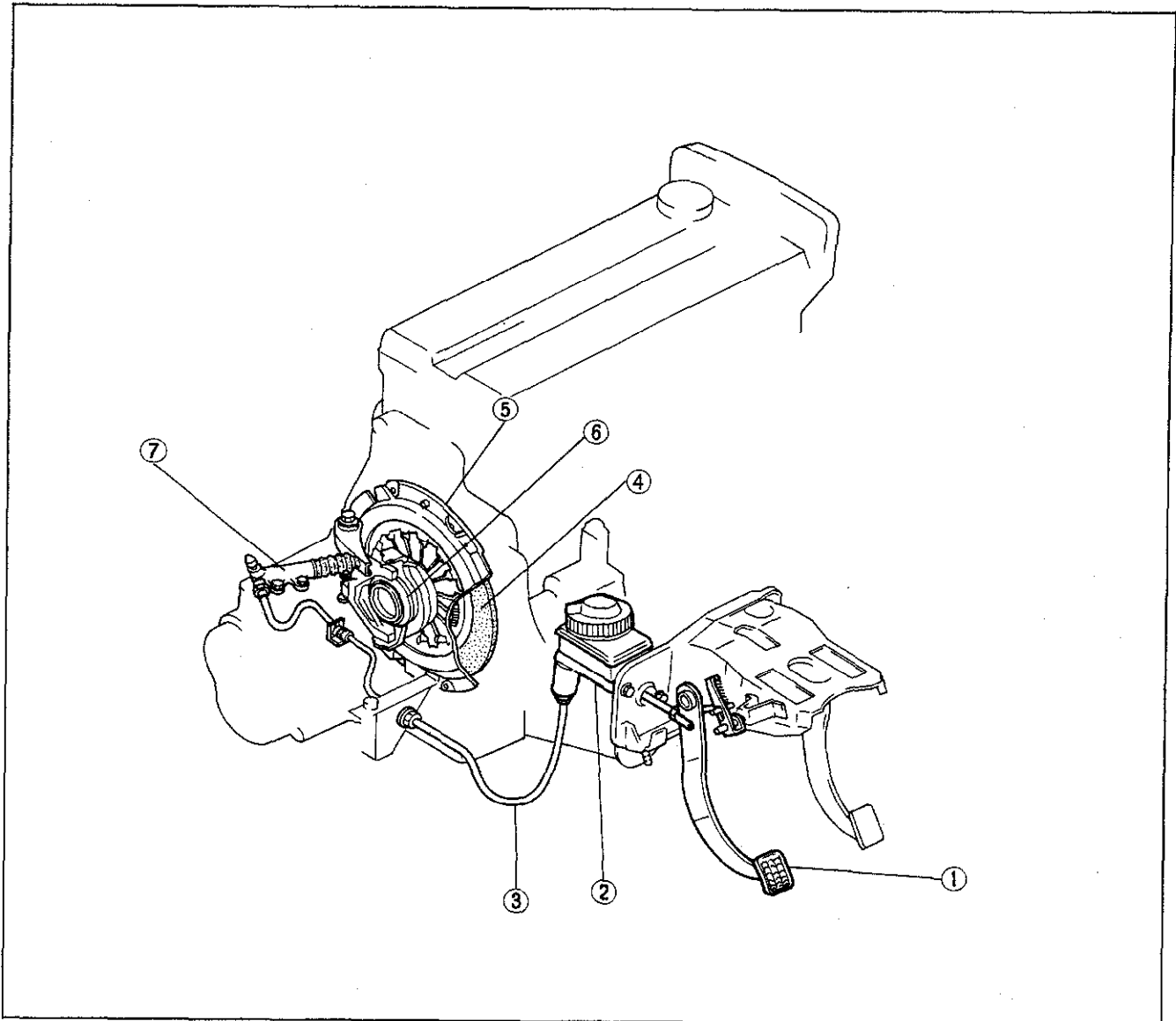

83U06X-003

- 1. Clutch pedal
- 2. Master cylinder
- 3. Pipe
- 4. Clutch disc

- 5. Clutch cover
- 6. Release bearing
- 7. Release cylinder

# 6 TROUBLESHOOTING GUIDE

## SPECIFICATIONS

Engine model			B6 EGI	B6 DOHC		
				2WD	4WD	
Clutch control			Cable		Hydraulic	
Clutch cover	Set load	N (kg, lb)	3277 (334, 735)	4316 (440, 968)		
Clutch disc	Outer diameter	mm (in)	190 (7.48)	225 (8.86)		
	Inner diameter	mm (in)	132 (5.20)	150 (5.91)		
	Thickness	Pressure plate side	mm (in)	3.5 (0.138)	4.1 (0.161)	
		Flywheel side	mm (in)	3.5 (0.138)		
Clutch pedal	Type	Suspended				
	Pedal ratio	6.2		5.96		
	Full stroke	mm (in)	145 (5.71)			
	Height	mm (in)	214.5 (8.44)	229 (9.02)		
Master cylinder inner diameter		mm (in)	—	—	15.87 (0.63)	
Release cylinder inner diameter		mm (in)	—	—	19.05 (0.75)	
Clutch fluid			—	—	SAE J1703a or FMVSS116, DOT-3 or DOT-4	

83U06X-004

## TROUBLESHOOTING GUIDE

Problem	Possible Cause	Remedy
<b>Slipping</b>	Clutch disc facing worn excessively Clutch disc facing surface hardened, or oil on surface Pressure plate damaged Diaphragm spring damaged or weakened Insufficient clutch pedal play Clutch pedal sticking Flywheel damaged	Replace Repair or replace Repair or replace Replace Adjust Repair or replace Repair or replace
<b>Faulty disengagement</b>	Excessive run-out or damaged of clutch disc Clutch disc splines rusted or worn Oil on facing Diaphragm spring weakened Excessive clutch pedal play Insufficient clutch fluid Leakage of clutch fluid	Replace Remove rust, or replace Repair or replace Replace Adjust Add fluid Repair or replace
<b>Clutch vibrates when starting</b>	Oil on facing Torsion spring weakened Clutch disc facing hardened or damaged Clutch disc facing rivets loose Pressure plate damaged or excessive run-out Flywheel surface hardened or damaged Loose or worn engine mount	Repair or replace Replace Repair or replace Replace Replace Repair or replace Tighten or replace
<b>Clutch pedal sticking</b>	Pedal shaft not properly lubricated	Lubricate or replace
<b>Abnormal noise</b>	Clutch release bearing damaged Poor lubrication of release bearing sleeve Torsion spring weakened Excessive crankshaft end play Pilot bearing worn or damaged Worn pivot points of release fork	Replace Lubricate or replace Replace Repair Replace Repair or replace

63G06X-304

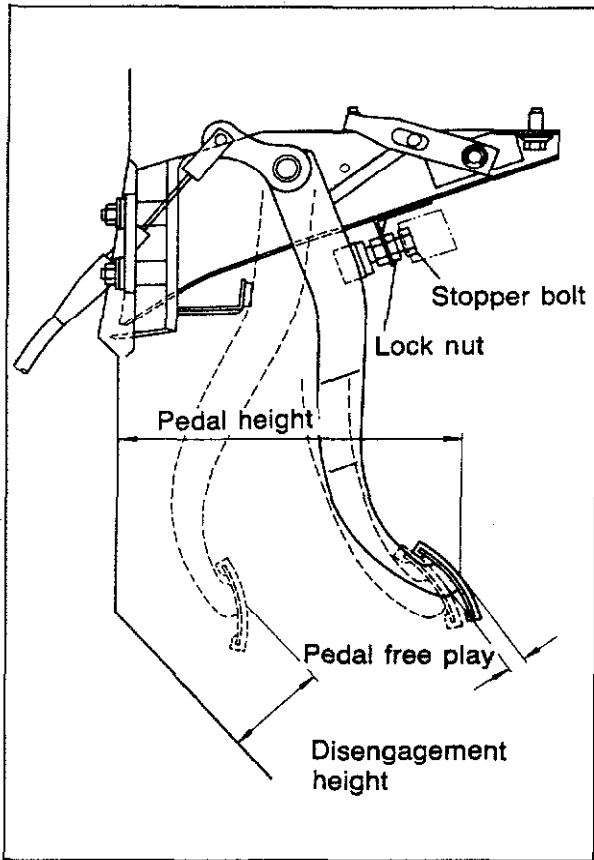

83U06X-005

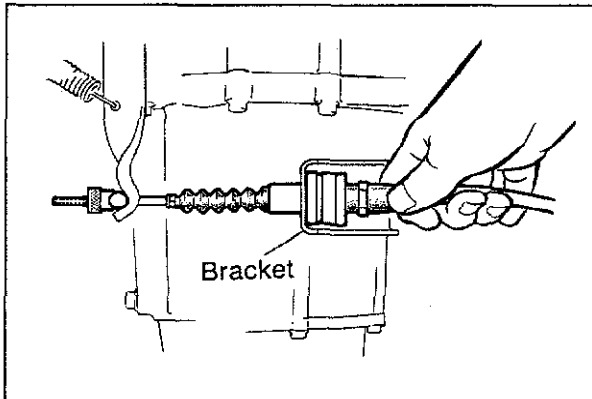

83U06X-006

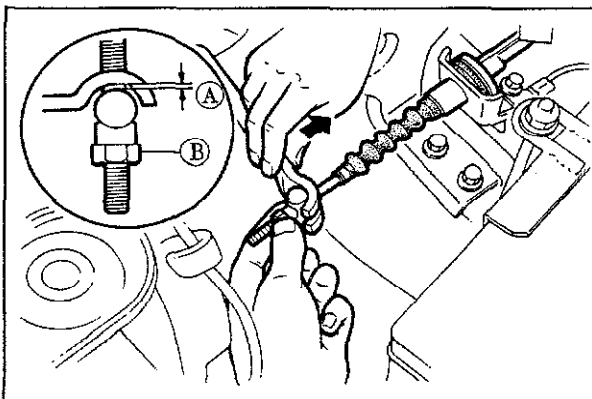

83U06X-007

## [Cable type] ON-VEHICLE MAINTENANCE

### PEDAL HEIGHT

#### Inspection

Measure the distance from the upper center of the pedal pad to the firewall and ensure the distance is within specification.

**Pedal height:**  $214.5 \pm 5 \text{ mm}$  ( $8.44 \pm 0.20 \text{ in}$ )

#### Adjustment

To adjust the pedal height, loosen locknut and turn clutch switch.

#### Note

**Remove the cover under the dashboard before carrying out this operation.**

### PEDAL FREEPLAY

#### Inspection

Depress the pedal lightly by hand and measure the freeplay, ensure that it is within specification.

**Pedal freeplay:** 9—15 mm (0.35—0.59 in)

#### Adjustment

1. Depress the clutch pedal seven times.
2. Straighten the clutch cable in the clutch cable bracket.

3. Depress the release lever and pull the pin away from the lever, then adjust clearance (A) by turning adjust nut (B).

**Clearance:**  $2 \pm 0.3 \text{ mm}$  ( $0.079 \pm 0.012 \text{ in}$ )

4. After adjustment, ensure that when the clutch is disengaged, the distance between the floor and the upper center of the pedal pad is within specification.

**Disengagement height:**  
85 mm (3.3 in) min.

## CLUTCH PEDAL

### REMOVAL

1. Remove the dashboard under cover and blower duct.
2. Remove the parts in the numbered sequence shown in the figure.

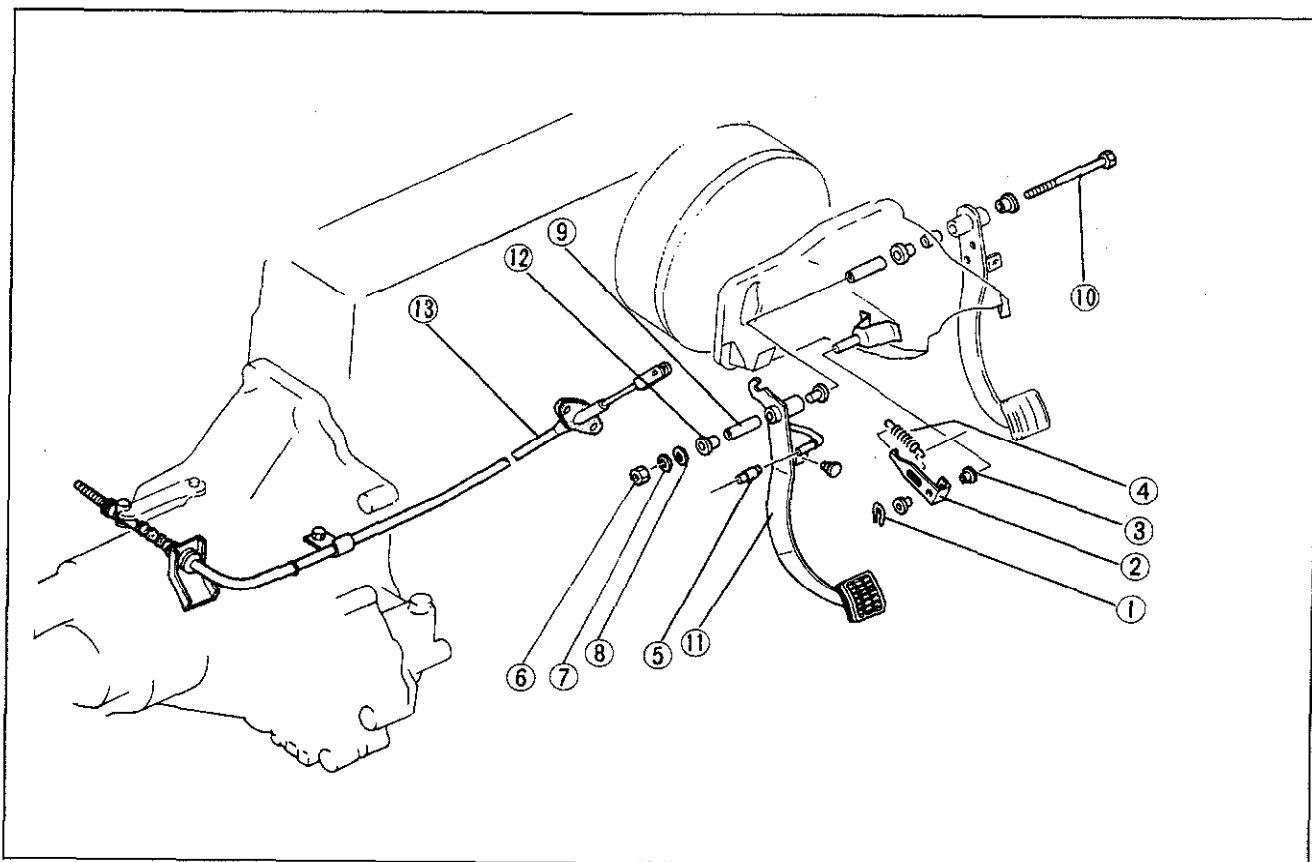

63U06X-007

1. Retaining ring
2. Lever
3. Bushing
4. Return spring

5. Bushing
6. Nut
7. Spring washer
8. Flat washer

9. Spacer
10. Through bolt
11. Clutch pedal
12. Bushing
13. Clutch cable

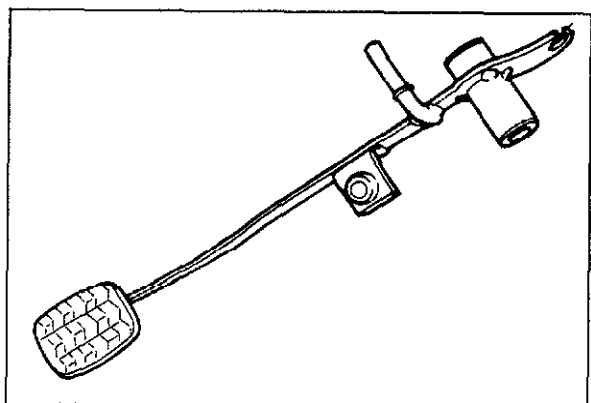

63U06X-008

### INSPECTION

Check the following, repair or replace if necessary:

1. Worn or damaged pedal bushing
2. Twisted or bent pedal
3. Worn or damaged pedal pad

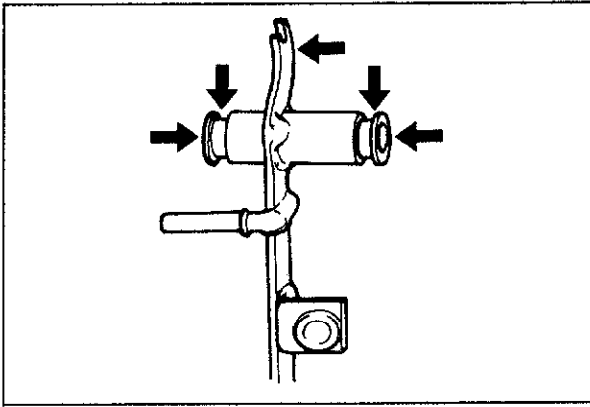

63U06X-009

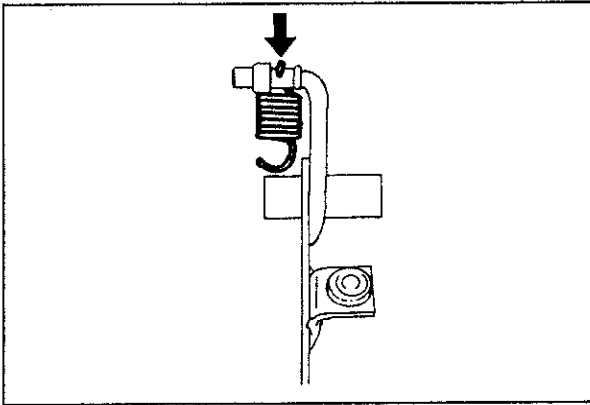

63U06X-010

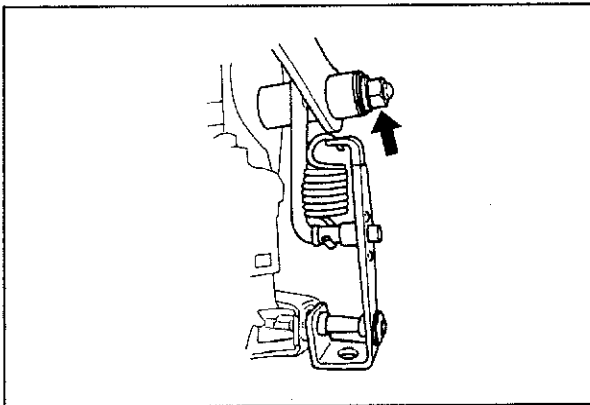

63U06X-011

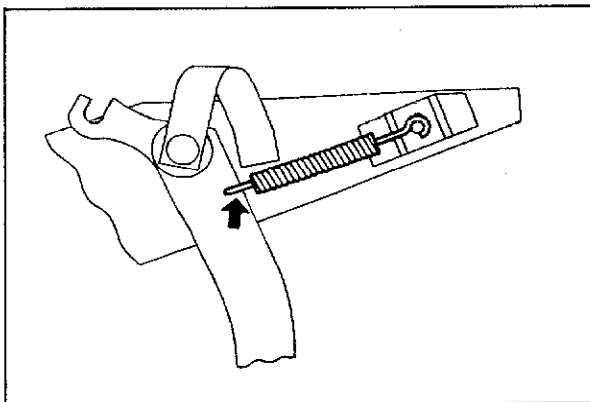

83U06X-016

## INSTALLATION

Install in the reverse order of removal and note the following:

1. Apply lithum grease to the inner and outer surfaces of the pedal bushing, pedal cable and hook unit.

2. Install the return spring to the bushing and apply lithum grease.

### Note

**Install spring in position shown.**

3. Install the clutch pedal and tighten the nut.

### Tightening torque

**20—35 N·m (2.0—3.5 m·kg, 14.5—25.3 ft·lb)**

4. After installation, adjust the pedal height and pedal freeplay.  
(Refer to Page 6—5)



# 6 CLUTCH CABLE

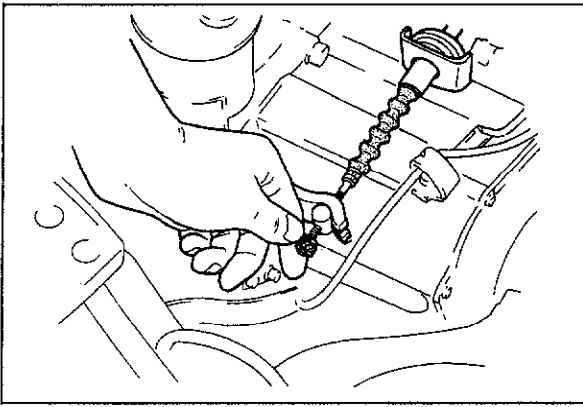

63U06X-013

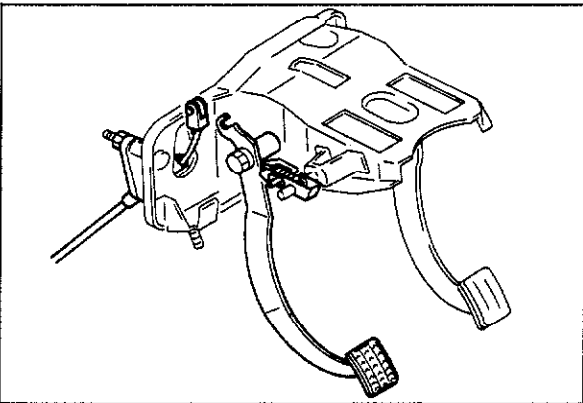

63U06X-014

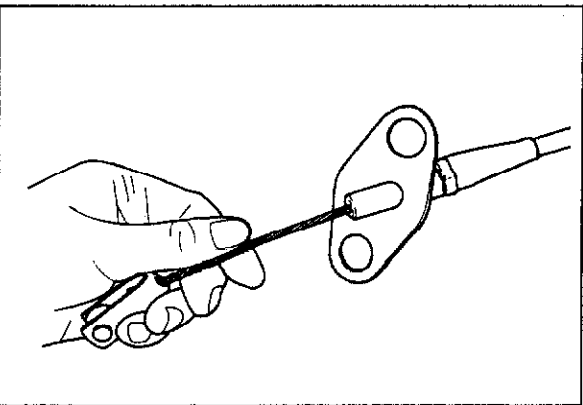

63U06X-015

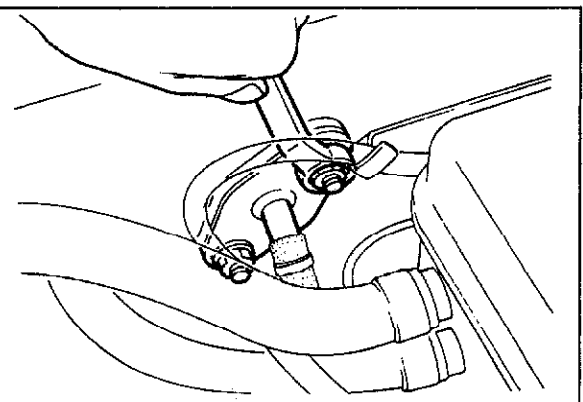

83U06X-017

## CLUTCH CABLE

### REMOVAL

1. Remove the adjusting nut and pin
2. Remove the clutch cable bracket.
3. Disconnect the cable from the pedal assembly.
4. Remove the cable from the engine compartment side.

### INSPECTION

Check the following, and replace if necessary:

1. Damage to the inner or outer cable
2. Function of the cable

### INSTALLATION

Install in the reverse order of removal and note the following:

1. Apply lithium grease to the pedal cable hook and the joint between the release lever and pin.
2. Install the clutch cable bracket.

#### Tightening torque

**16—23 N·m (1.6—2.3 m·kg, 12—17 ft·lb)**

3. Adjust the pedal freeplay (Refer to Page 6—5)

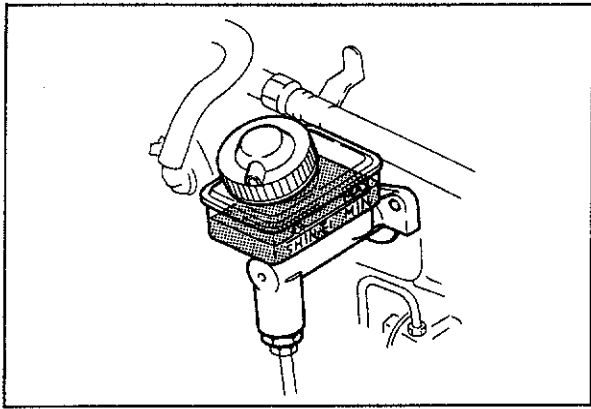

83U06X-009

## [Hydraulic type] ON-VEHICLE MAINTENANCE

### FLUID LEVEL

1. Clean the area around the reservoir and the reservoir cap.
2. Check the fluid level. If the level is near or below the "MIN" mark, add brake fluid to the "MAX" mark.

### Fluid specification:

**DOT-3 or DOT-4**

**(FMVSS 116, or SAEJ1703a)**

## INSPECTION AND ADJUSTMENT

### CLUTCH PEDAL HEIGHT

#### Inspection

Measure the distance from the upper surface of the pedal pad to the firewall, after removing the carpet.

#### Standard height:

**229 ± 5 mm (9.02 ± 0.20 in)**

#### Adjustment

1. Adjust the clutch pedal height by loosening lock nut (A) and turning clutch switch (B).
2. After the adjustment, tighten lock nut (A).

### CLUTCH PEDAL PLAY

#### Inspection

Depress the clutch pedal lightly by hand and measure the free play.

**Standard play: 0.6—3.0 mm (0.02—0.12 in)**

#### Adjustment

1. Adjust the free play by loosening lock nut (C) and turning push rod (D).
2. After adjustment, tighten lock nut (C).
3. Check that the distance from the floor to the center of the upper surface of the pedal pad is correct when the clutch is fully disengaged. If it is not within specification, readjust.

#### Disengagement height:

**82 mm (3.23 in) min.**

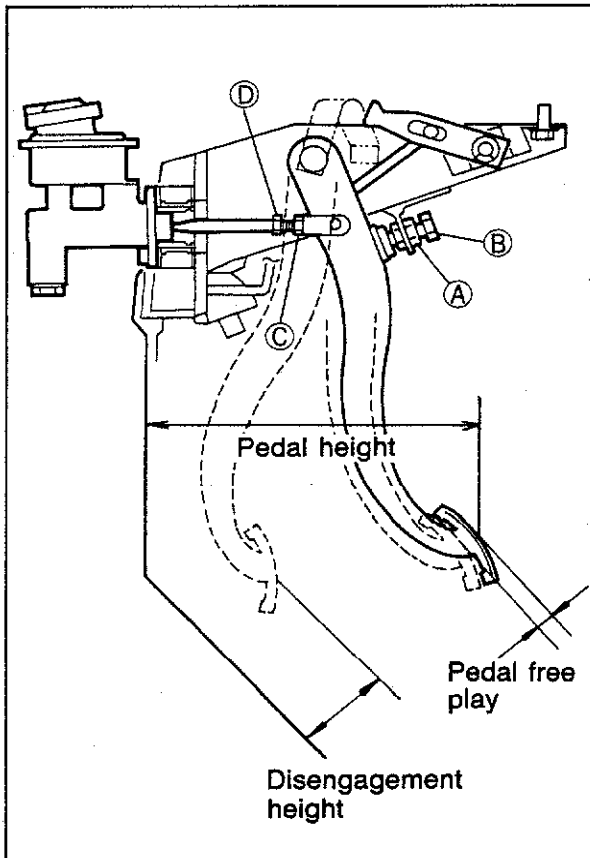

83U06X-018

# 6 CLUTCH PEDAL

## CLUTCH PEDAL

### REMOVAL AND INSTALLATION

1. Remove the parts in the sequence shown in the figure.
2. Install in the reverse order of removal.
3. Adjust the clutch pedal free play.

67U06X-006

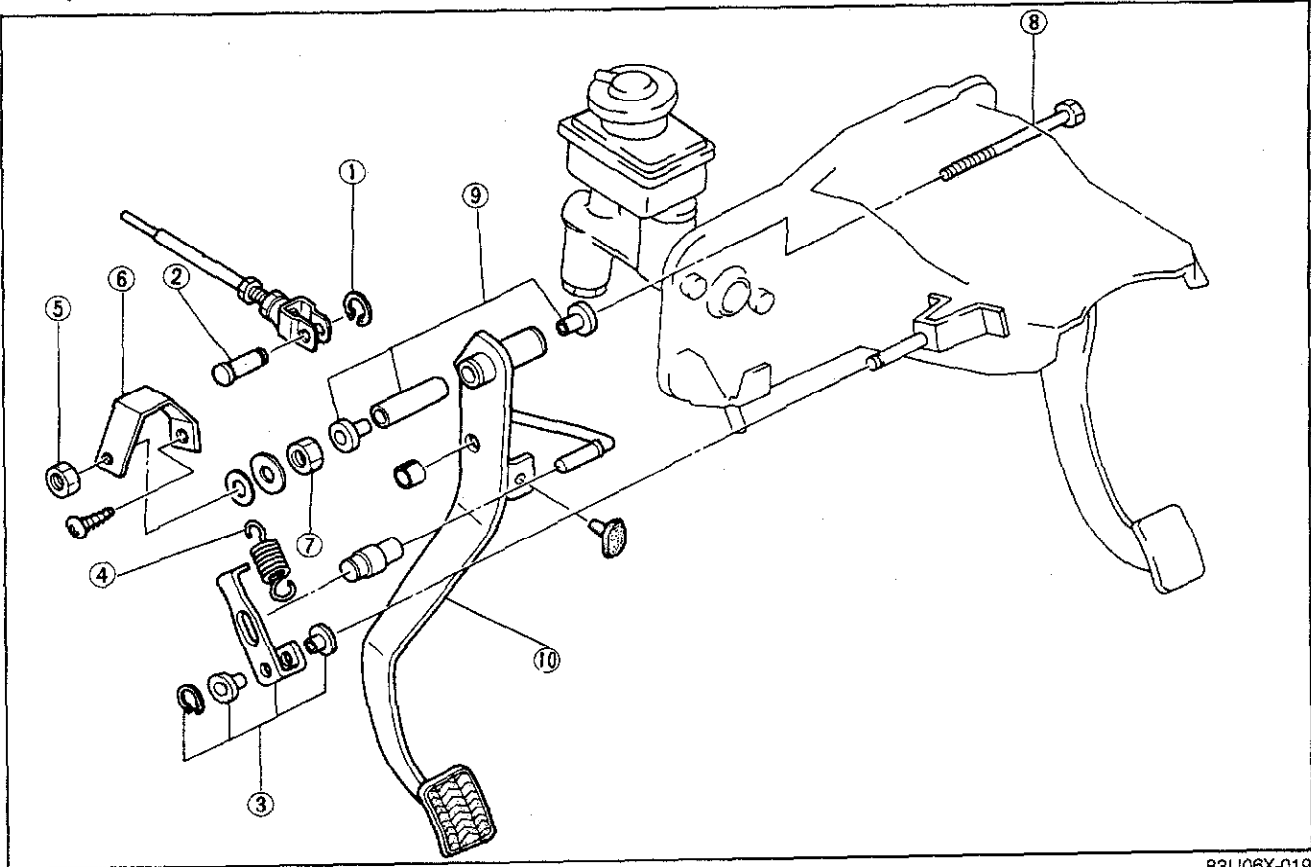

83U06X-019

1. Clip
2. Push rod
3. Clip, bushing and washer
4. Spring
5. Nut

6. Cover
7. Nut
8. Bolt
9. Bushing and washer
10. Clutch pedal

### Caution

Apply grease (lithium base, NLGI No. 2) to the bushings and pivot points.

### INSPECTION

Check the following, parts replace if necessary.

1. Worn or damaged bushings.
2. Twisted or bent clutch pedal.
3. Worn or damaged pedal pad.

48G06X-121

## MASTER CYLINDER

### REMOVAL AND INSTALLATION

1. Remove the parts in the sequence shown in the figure.
2. Install in the reverse order of removal.
3. After installation, perform air bleeding.

67U06X-008

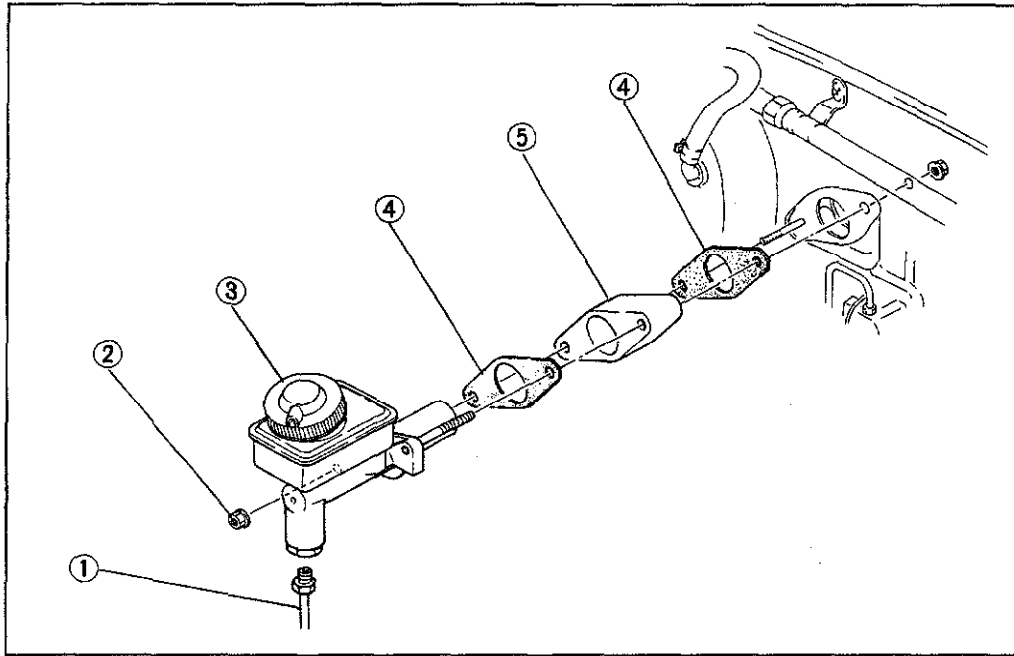

1. Clutch pipe
2. Nut
3. Master cylinder
4. Gaskst.
5. Spacer.

67U06X-009

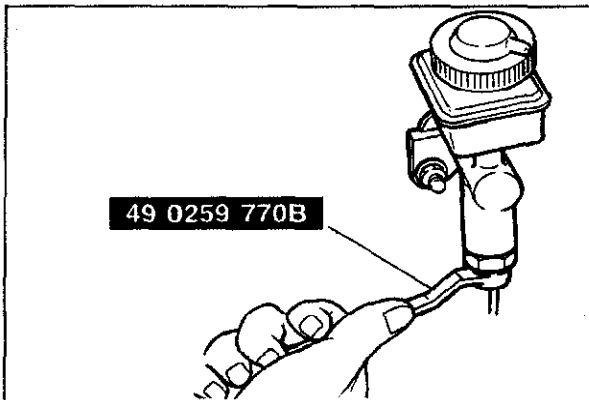

83U06X-020

### Clutch Pipe

Use **SST** to disconnect and connect the clutch pipe.

### Caution

**Clutch fluid will damage painted surfaces. Use a container or rags to collect the fluid. If fluid does get on a painted surface, wipe it off immediately.**

# 6 MASTER CYLINDER

## DISASSEMBLY AND ASSEMBLY

1. Disassemble the parts in the sequence shown in the figure.
2. Assemble in the reverse order of removal.
3. Disassemble and assemble in a clean location free from dirt and dust.
4. Use clutch fluid to wash the inner parts.

67U06X-012

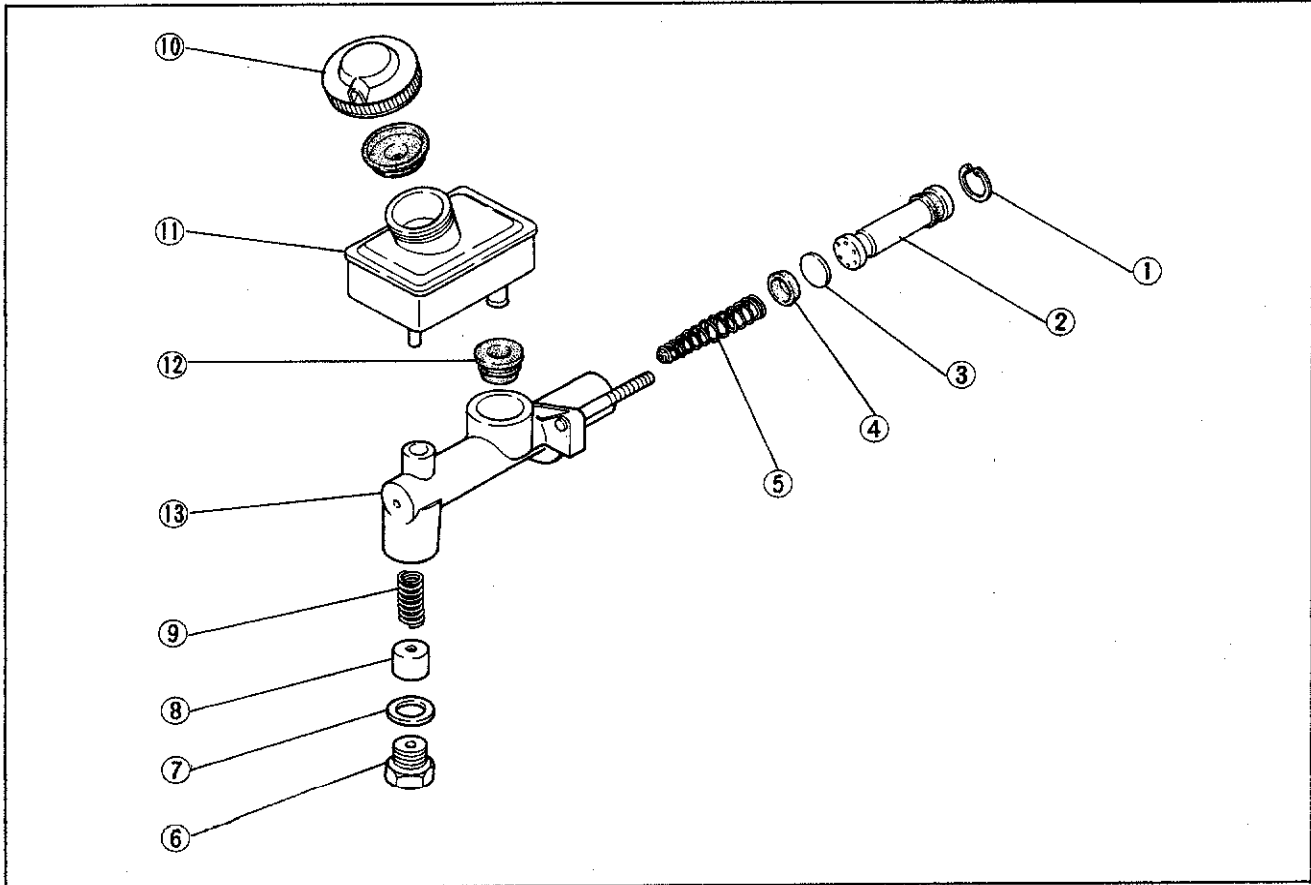

83U06X-021

1. Snap ring
2. Piston and secondary cup assembly
3. Protector
4. Primary cup
5. Return spring
6. Joint bolt
7. Gasket

8. One-way valve piston
9. One-way valve spring
10. Cap
11. Reservoir
12. Bushing
13. Cylinder body

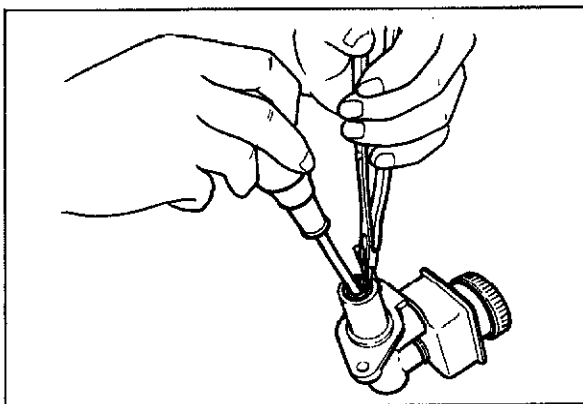

4BG06X-010

### Snap Ring

Press down on the piston and remove the snap ring with snap ring pliers.

### Caution

**Do not damage push rod contact surface of piston.**

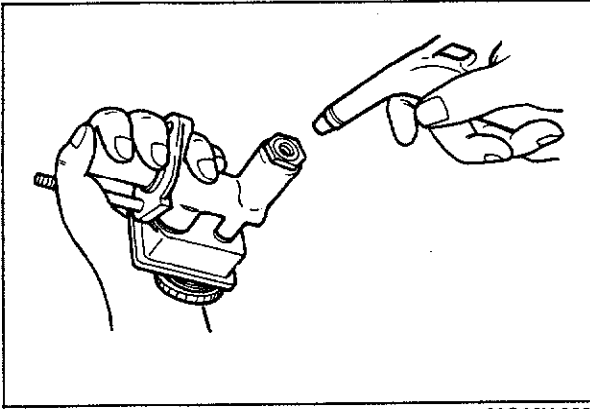

63G06X-309

## Piston and Secondary Cup Assembly

Remove the piston and secondary cup assembly by compressed air.

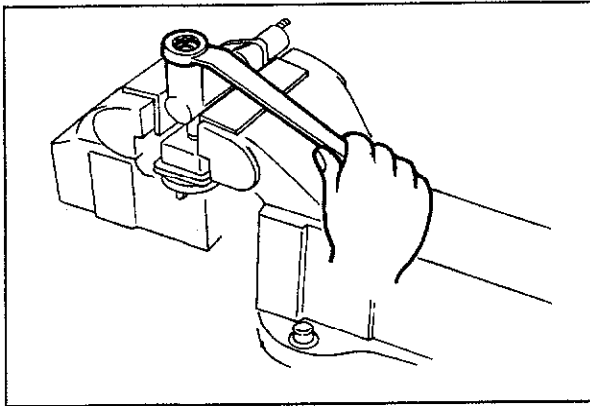

63G06X-310

## One-way Valve

1. Remove the joint bolt.

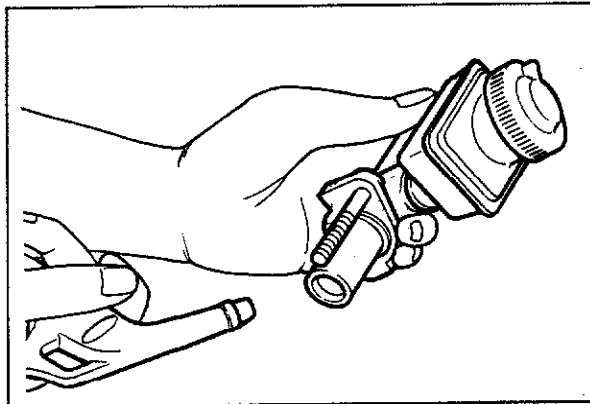

63G06X-311

2. Remove the one-way valve piston and spring by compressed air.

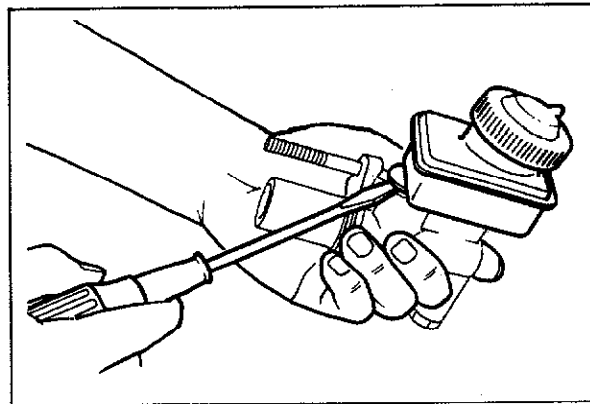

63G06X-312

## Reservoir

Pry the reservoir off the body.

# 6 MASTER CYLINDER

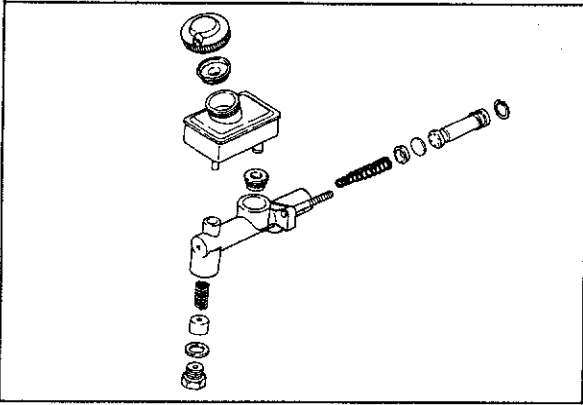

63G06X-313

## INSPECTION

After cleaning each part, check the following parts, replace if necessary. Note that rubber parts should be cleaned with brake fluid.

1. Wear or damage to master cylinder bore and piston.
2. Weakness of return spring.
3. Wear or damage to primary or secondary cups.

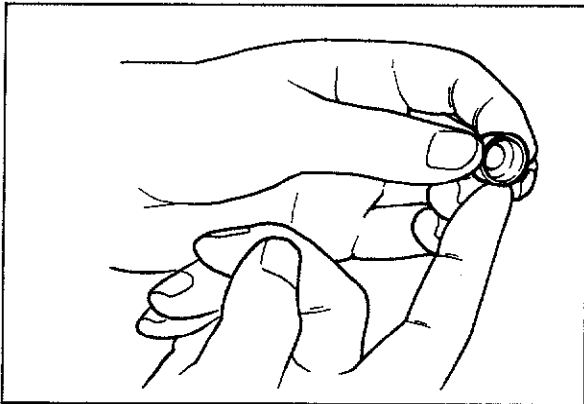

63G06X-314

## ASSEMBLY

Assemble the clutch master cylinder in the reverse order of disassembly.

### Note

- a) Before assembling, coat the edges of the piston and cups with clean brake fluid.
- b) After assembling, fill the cylinder with new brake fluid and operate the piston with a screwdriver until fluid is ejected from the outlet.

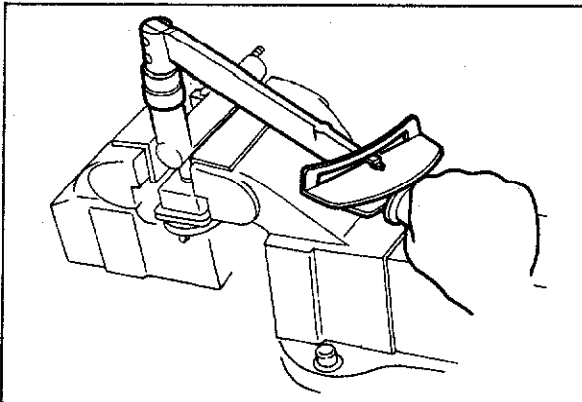

63G06X-315

### Joint bolt tightening torque:

83—113 N·m

(8.5—11.5 m·kg, 61—83 ft·lb)

## RELEASE CYLINDER

### REMOVAL AND INSTALLATION

1. Remove the parts in the sequence shown in the figure.
2. Install in the reverse order of removal.
3. After installation, perform air bleeding.

67U06X-016

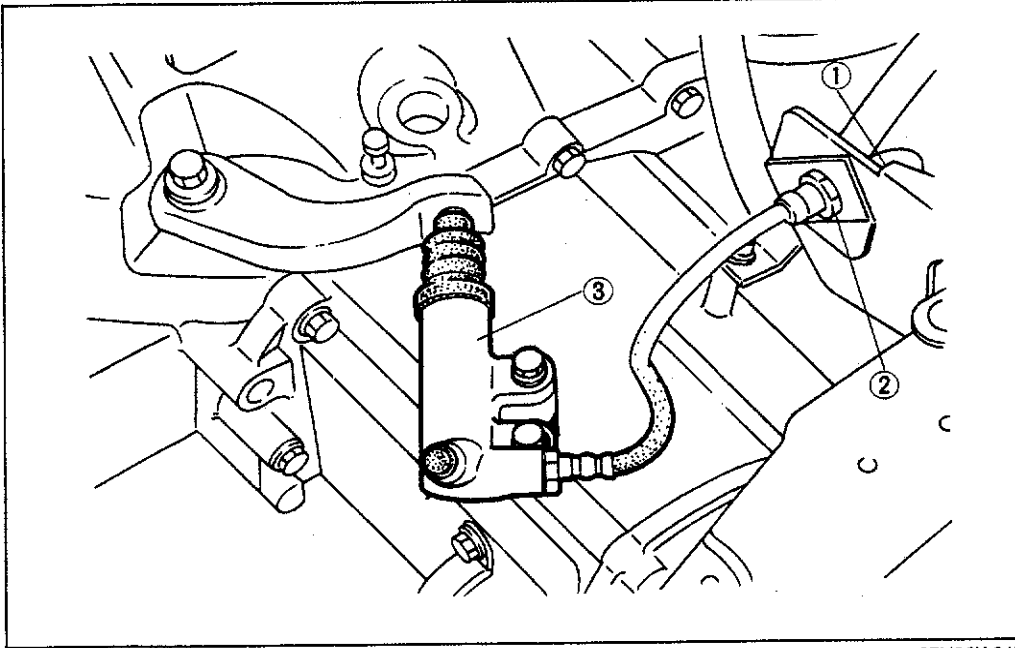

1. Clutch pipe
2. Clip
3. Release cylinder

67U06X-017

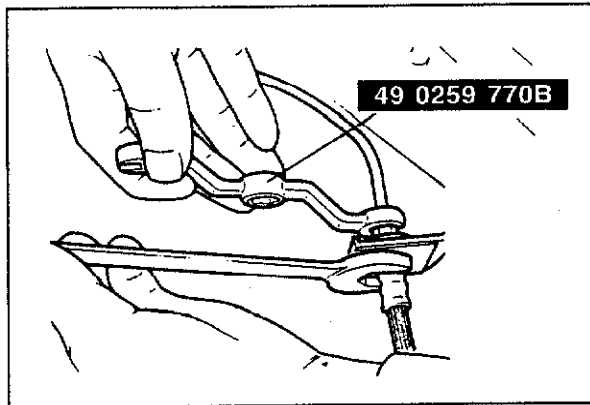

83U06X-022

#### Flare Nut

Use **SST** to loosen and tighten the flare nut of the clutch pipe.

#### Note

**After disconnecting the clutch pipe, plug it to avoid fluid leakage.**

#### Caution

**Clutch fluid will damage painted surfaces. Use a container or rags to collect the fluid. If fluid does get on a painted surface, wipe it off immediately.**

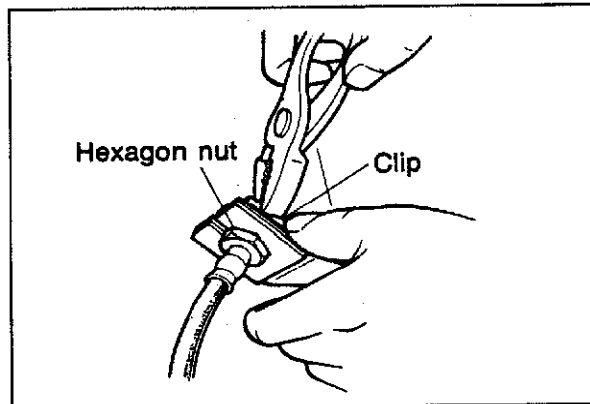

67U06X-019

#### Clip

When assembling, insert the clip between the bracket and flare nut of the clutch pipe.

#### Caution

- a) The hexagon nut must seat correctly into the hexagonal groove of the bracket.
- b) The flexible hose must not be twisted.



# 6 RELEASE CYLINDER

## DISASSEMBLY, INSPECTION AND ASSEMBLY

1. Disassemble the parts in the sequence shown in the figure.
2. Assemble in the reverse order of removal.
3. Disassemble and assemble in a clean location free from dirt and dust.
4. Use brake fluid to wash the inner parts.
5. To inspect, refer to master cylinder section.

63G06X-316

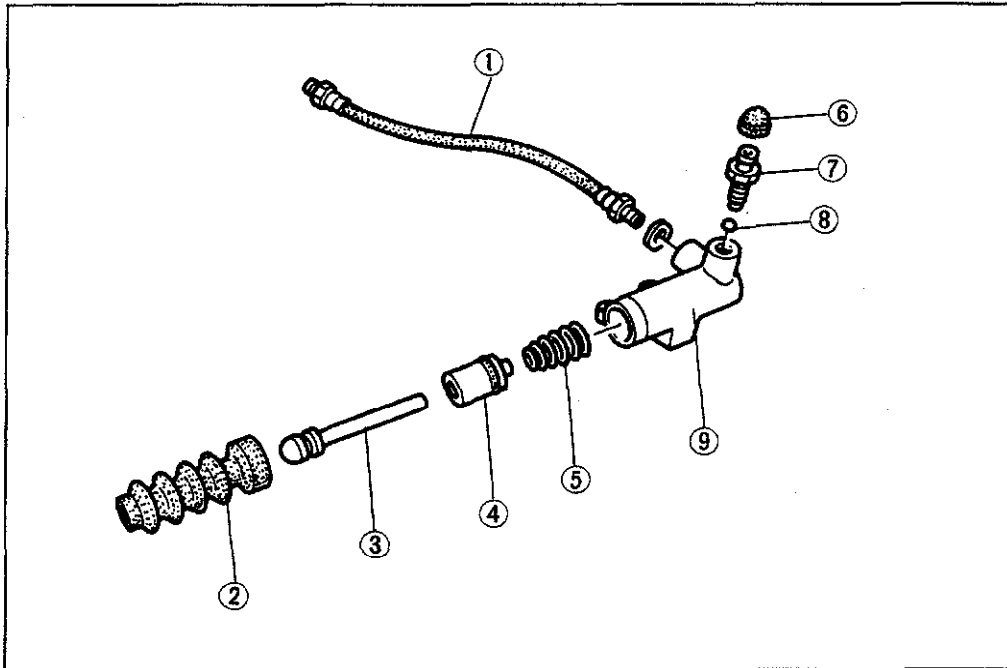

1. Flexible hose
2. Boot
3. Push rod
4. Piston and cap assembly
5. Return spring
6. Bleeder cap
7. Bleeder plug
8. Steel ball
9. Release cylinder

83U06X-023

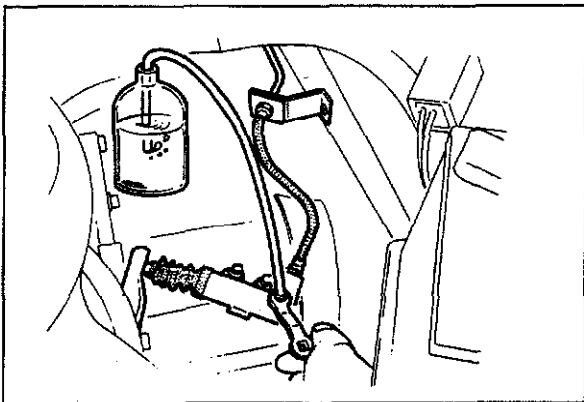

4BG06X-015

## AIR BLEEDING

The clutch hydraulic system must be bled to remove air which has entered when the pipes are disconnected for repairs, etc. This bleeding is done as described below.

### Caution

- a) The fluid in the reservoir tank must be maintained at the 3/4 level or higher during air bleeding.
- b) Be careful not to spill clutch fluid onto a painted surface

1. Remove the bleeder cap and attach a vinyl tube to the bleeder plug.
2. Place the other end of the vinyl tube in a container.
3. Slowly pump the clutch pedal several times.
4. While the clutch pedal is pressed, loosen the bleeder screw to let fluid and air escape. Then tighten the bleeder screw.
5. Repeat steps 3 and 4 until there are no more air bubbles in the fluid.
6. Check for correct clutch operation.

83U06X-024

## CLUTCH AND FLYWHEEL

### REMOVAL

1. Remove the transaxle (Refer to Section 7A).
2. For removing the clutch cover and clutch disc, use the **SST**.

#### Note

To avoid dropping the disc, use the clutch disc centering tool (49 SE01 310).

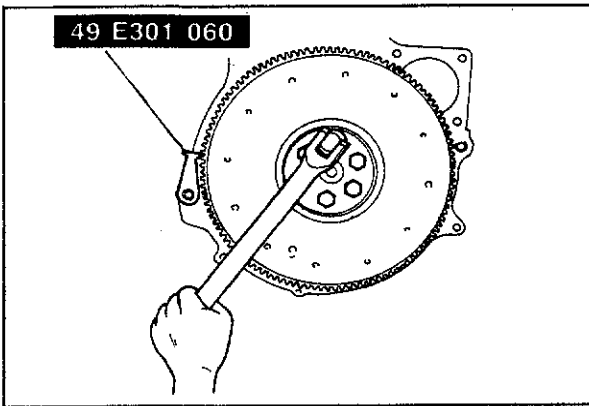
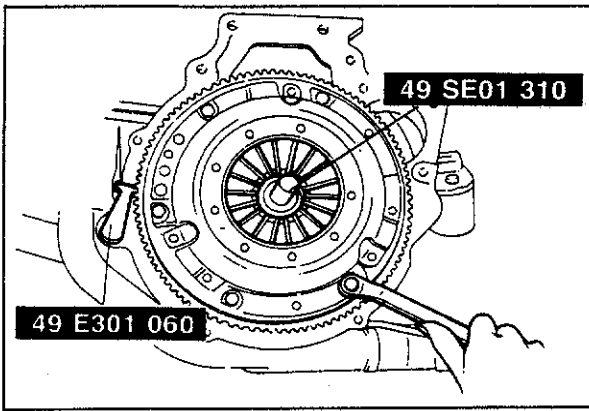

3. Remove the flywheel mounting bolts, and then remove the flywheel.

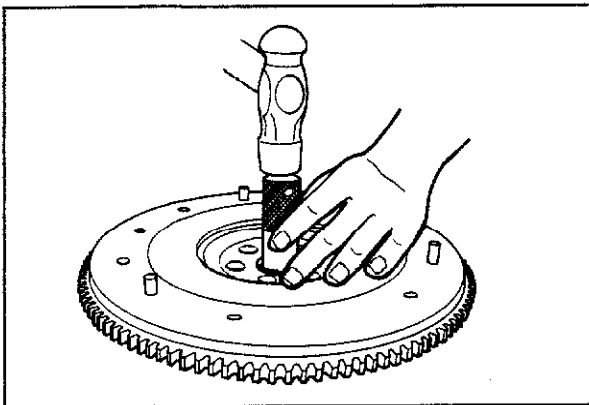

4. Remove the pilot bearing from the flywheel with a suitable rod and a hammer.

#### Note

Do not remove the bearing if it is not necessary.

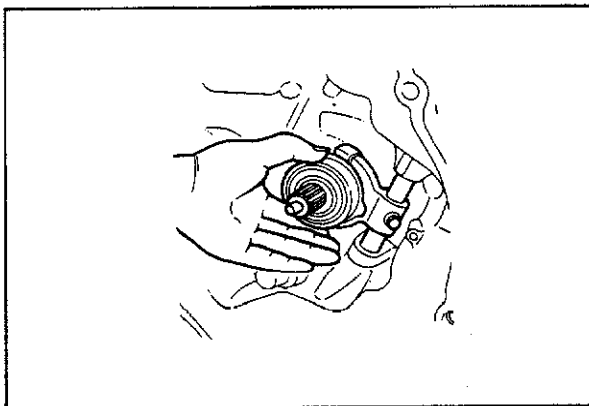

5. Remove the return spring and release bearing.
6. Remove the bolt holding the release fork and release lever together.
7. Remove the release fork and set key by pulling the release lever out of the case.

# 6 CLUTCH AND FLYWHEEL

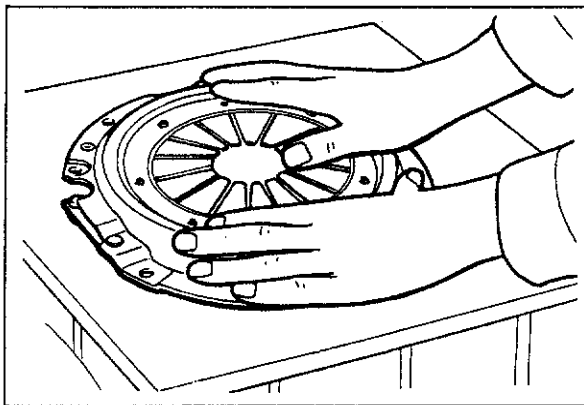

63U06X-021

## INSPECTION

Check the following parts, and repair or replace if necessary:

### Clutch Cover

1. Contact surface of the clutch disc for scoring, cracks, or discoloration.

#### Note

**Minor scratches or discoloration should be removed with sandpaper.**

2. Diaphragm spring for damage, or damage to the cover.

### Clutch Disc

1. Facing surface for hardening or presence of oil.

#### Note

**Use sandpaper if the trouble is minor.**

2. Loose facing rivets.
3. Worn clutch disc.  
Measure the depth to the rivet heads with a slide caliper.

**Depth: 0.3 mm (0.012 in) min.**

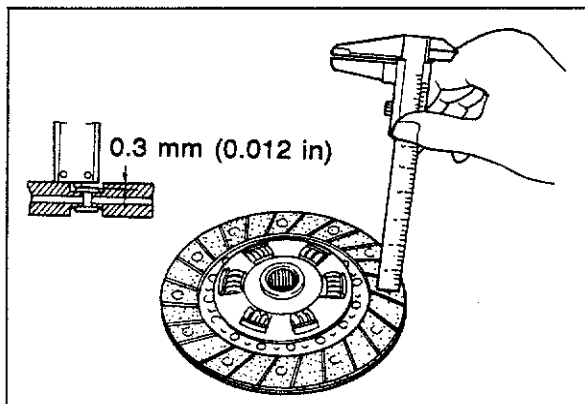

83U06X-011

4. Run-out of clutch disc.

**Lateral run-out limit: 0.7 mm (0.027 in)**  
**Vertical run-out limit: 1.0 mm (0.039 in)**

5. Wear or rust on the splines.  
Remove any minor rust.

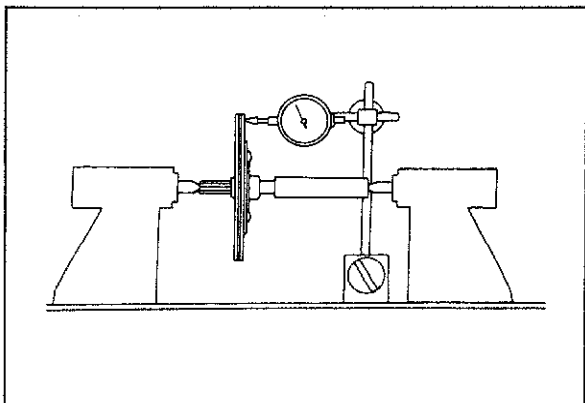

4BG06X-109

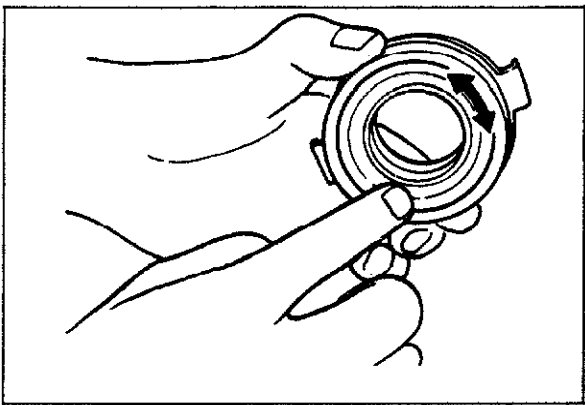

83U06X-012

### Clutch Release Bearing

1. Turn the bearing both directions and check for any binding or abnormal noise.
2. Worn or damaged diaphragm spring or release fork contact surface.

#### Note

**The clutch release bearing is a sealed bearing and must not be washed.**

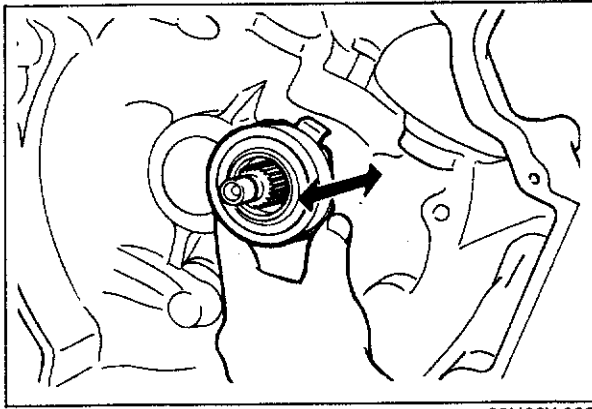

63U06X-025

- Sliding condition of bearing.  
Install the bearing on the clutch housing extension and check for smooth movement.

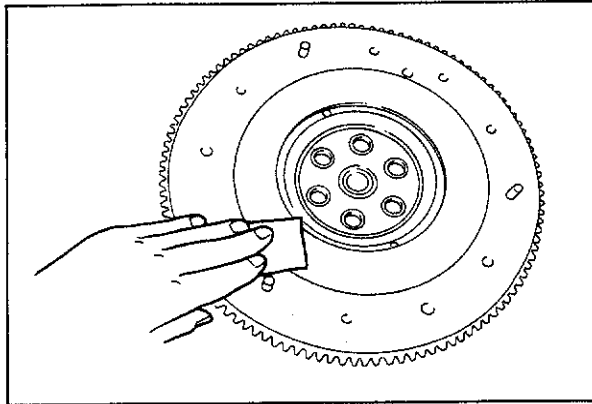

86U06X-025

## Flywheel

- Surface marks, scoring or discoloration of clutch disc contact surface.

### Note

**If problem is minor, repairs can be made by cleaning with sandpaper.**

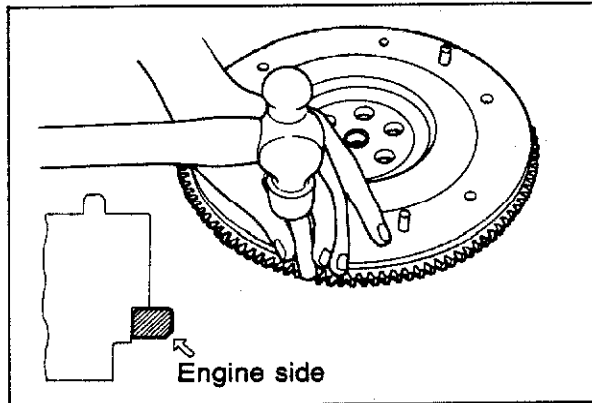

83U06X-013

- Damaged or worn ring gear teeth.  
If necessary, replace the ring gear as follows:

- Heat the ring gear with a blowtorch, and then tap around the gear to remove it from the flywheel.
- Heat the new ring gear to 250—300°C (480—570°F), and then fit it onto the flywheel.

### Note

**The bevelled side of the ring gear must face toward the engine side.**

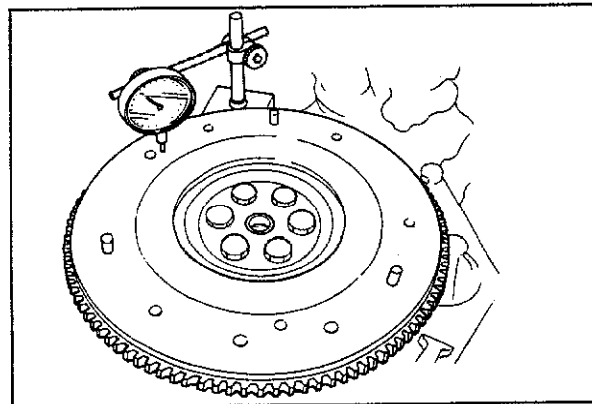

4BG06X-030

- Deflection of flywheel  
(1) To measure, set a dial gauge on the clutch disc contact surface, and then turn the flywheel.

**Deflection limit: 0.2 mm (0.008 in)**

- If the deflection exceeds the limit, repair by grinding.

**Grinding limit: 0.5 mm (0.020 in)**

## 6 CLUTCH AND FLYWHEEL

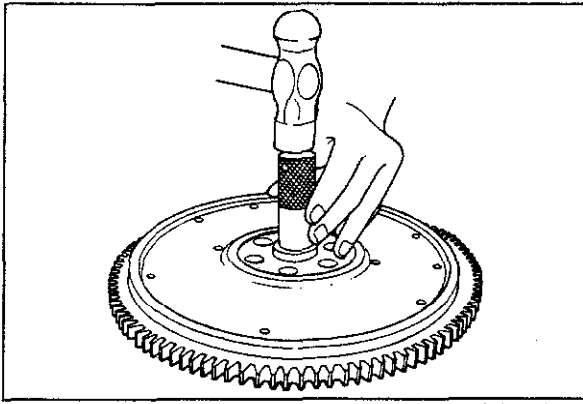

63U06X-029

### INSTALLATION

Install in the reverse order of removal and note the following:

1. Install the pilot bearing in the flywheel with a suitable rod and a hammer.

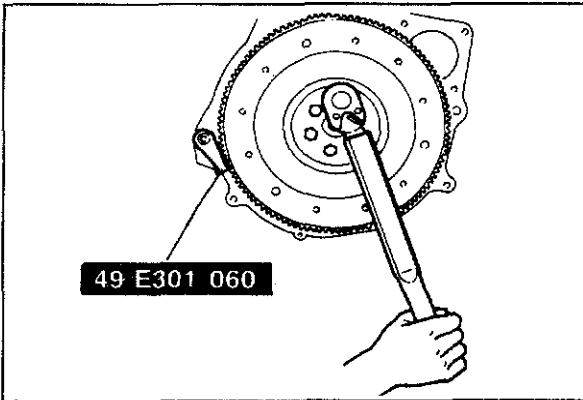

83U06X-014

2. After installing the flywheel, attach the **SST** and tighten the flywheel installation bolts.

### Tightening torque

**96—103 N·m (9.8—10.5 m·kg, 71—75 ft·lb)**

### Note

**If reinstalling flywheel bolts clean threads to remove old sealant, apply new sealant and tighten to specification.**

**If old sealant can not be removed replace bolts.**

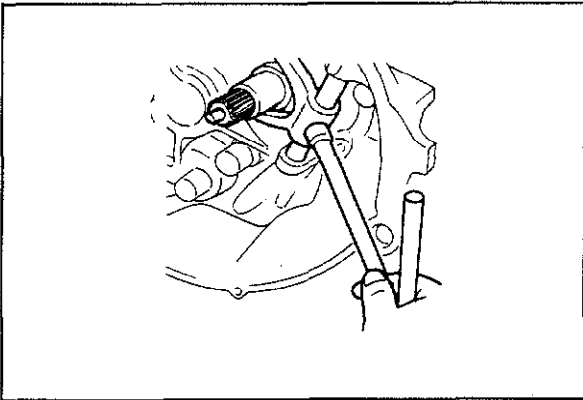

63U06X-031

3. Install the release lever and apply a coating sealant the bolt.

### Tightening torque

**7.8—10.8 N·m (0.8—1.1 m·kg, 5.8—8.0 ft·lb)**

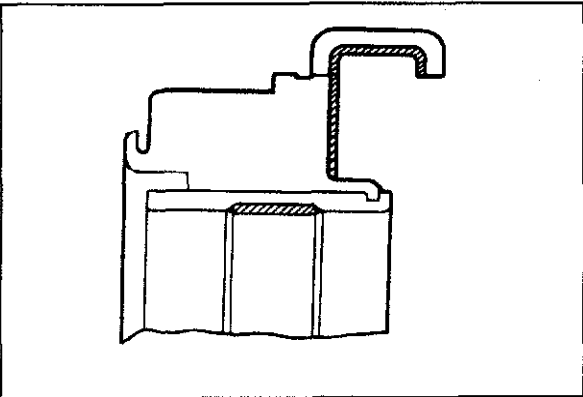

63U06X-032

4. Apply clutch grease (Mori White TA No. 2 or equivalent organic molybdenum grease) to the shaded areas of the release bearing.

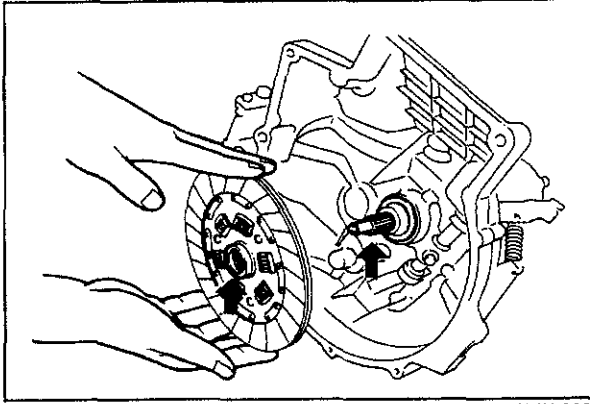

63U06X-033

5. Clean the clutch disc splines and primary shaft splines, then apply clutch grease. (Mori White TA No. 2 or equivalent organic molybdenum grease)

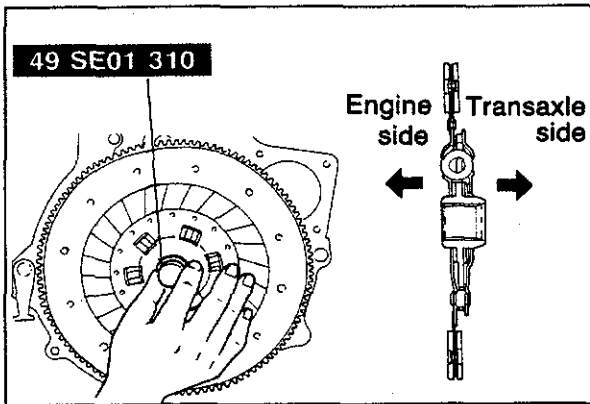

63U06X-015

6. Install the clutch disc by using the **SST**.

**Note**

Install the clutch so that it faces in the direction shown in the figure.

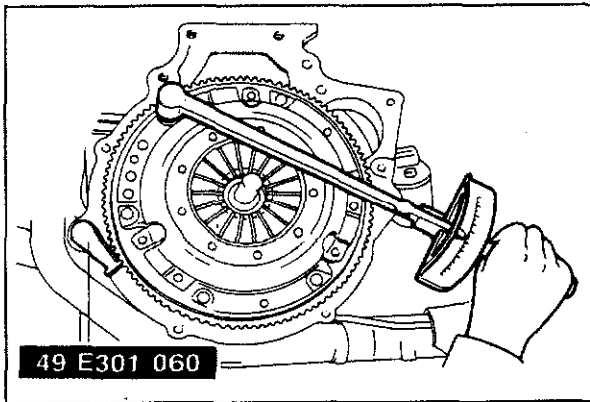

83U06X-026

7. Tighten the pressure plate gradually, diagonally and evenly. Use the **SST**.

**Tightening torque**

18—26 N·m (1.8—2.6 m·kg, 13.0—20.3 ft·lb)

# MANUAL TRANSAXLE 2WD

## F-type (Non-Turbo)

<b>OUTLINE</b> .....	7A— 2
STRUCTURAL VIEW .....	7A— 2
CROSS-SECTIONAL VIEW .....	7A— 4
SPECIFICATIONS .....	7A— 6
<b>TROUBLESHOOTING GUIDE</b> .....	7A— 7
<b>ON-VEHICLE MAINTENANCE</b> .....	7A— 8
TRANSAXLE OIL .....	7A— 8
DRIVESHAFT OIL SEALS.....	7A— 9
<b>REMOVAL</b> .....	7A—12
<b>DISASSEMBLY</b> .....	7A—15
STEP 1 .....	7A—15
STEP 2 .....	7A—19
STEP 3 .....	7A—22
DIFFERENTIAL .....	7A—25
<b>INSPECTION</b> .....	7A—26
<b>ASSEMBLY</b> .....	7A—30
DIFFERENTIAL .....	7A—30
STEP 1 .....	7A—32
STEP 2 .....	7A—42
STEP 3 .....	7A—44
<b>INSTALLATION</b> .....	7A—78
<b>TRANSAXLE CONTROL</b> .....	7A—81
REMOVAL.....	7A—81
INSPECTION .....	7A—82
INSTALLATION .....	7A—82

## G-type (Turbo)

<b>OUTLINE</b> .....	7A— 3
STRUCTURAL VIEW .....	7A— 3
CROSS-SECTIONAL VIEW.....	7A— 5
SPECIFICATIONS .....	7A— 6
<b>TROUBLESHOOTING GUIDE</b> .....	7A— 7
<b>ON-VEHICLE MAINTENANCE</b> .....	7A— 8
TRANSAXLE OIL .....	7A— 8
DRIVESHAFT OIL SEALS.....	7A— 9
<b>REMOVAL</b> .....	7A—12
<b>DISASSEMBLY</b> .....	7A—49
STEP 1 .....	7A—49
STEP 2 .....	7A—52
STEP 3 .....	7A—54
DIFFERENTIAL .....	7A—56
<b>INSPECTION</b> .....	7A—58
<b>ASSEMBLY</b> .....	7A—62
<b>INSTALLATION</b> .....	7A—78
<b>TRANSAXLE CONTROL</b> .....	7A—81
REMOVAL.....	7A—81
INSPECTION .....	7A—82
INSTALLATION .....	7A—82

## OUTLINE (F-type)

### STRUCTURAL VIEW

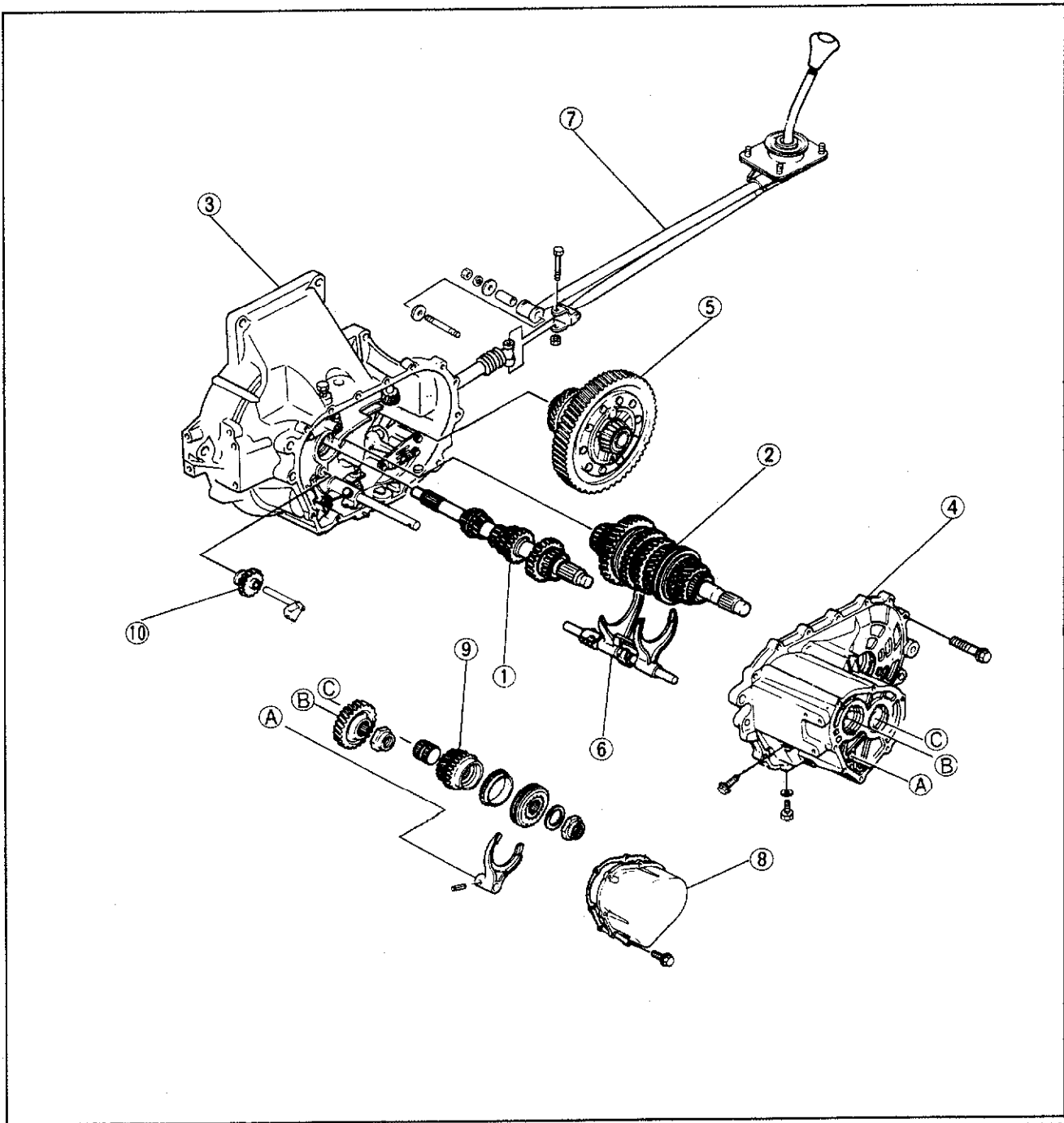

83U07A-002

- 1. Primary shaft gear assembly
- 2. Secondary shaft gear assembly

- 3. Clutch housing
- 4. Transaxle case
- 5. Differential assembly
- 6. Shift fork and shift rod assembly

- 7. Transaxle control assembly
- 8. Rear cover
- 9. 5th gear
- 10. Reverse idle gear



OUTLINE (G-type)

STRUCTURAL VIEW

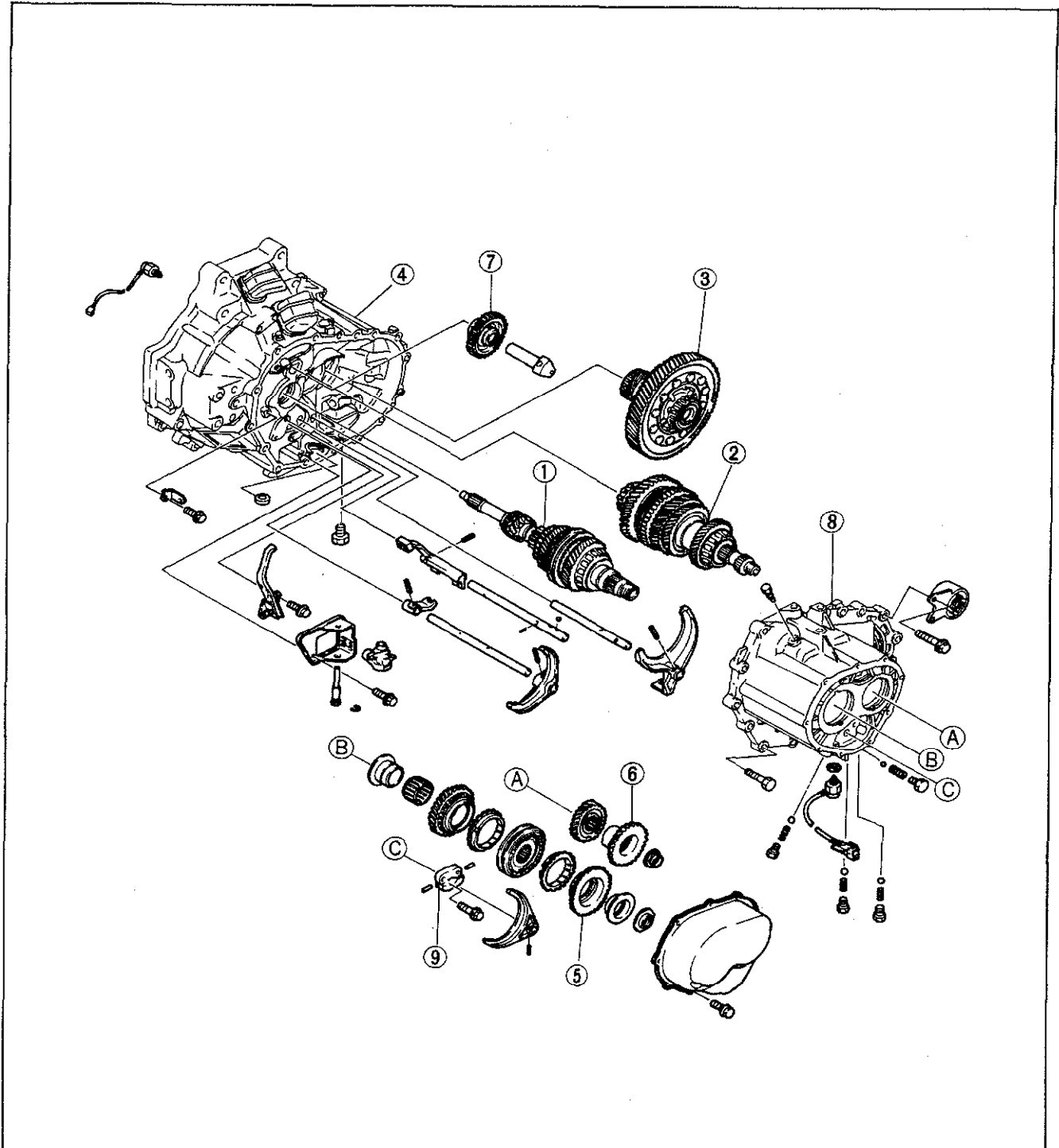

86U07A-046

- 1. Primary shaft gear assembly
- 2. Secondary shaft gear assembly
- 3. Differential assembly
- 4. Clutch housing

- 5. Primary reverse synchronizer gear
- 6. Secondary reverse synchronizer gear
- 7. Reverse idle gear
- 8. Transaxle case

## CROSS-SECTIONAL VIEW (F-type)

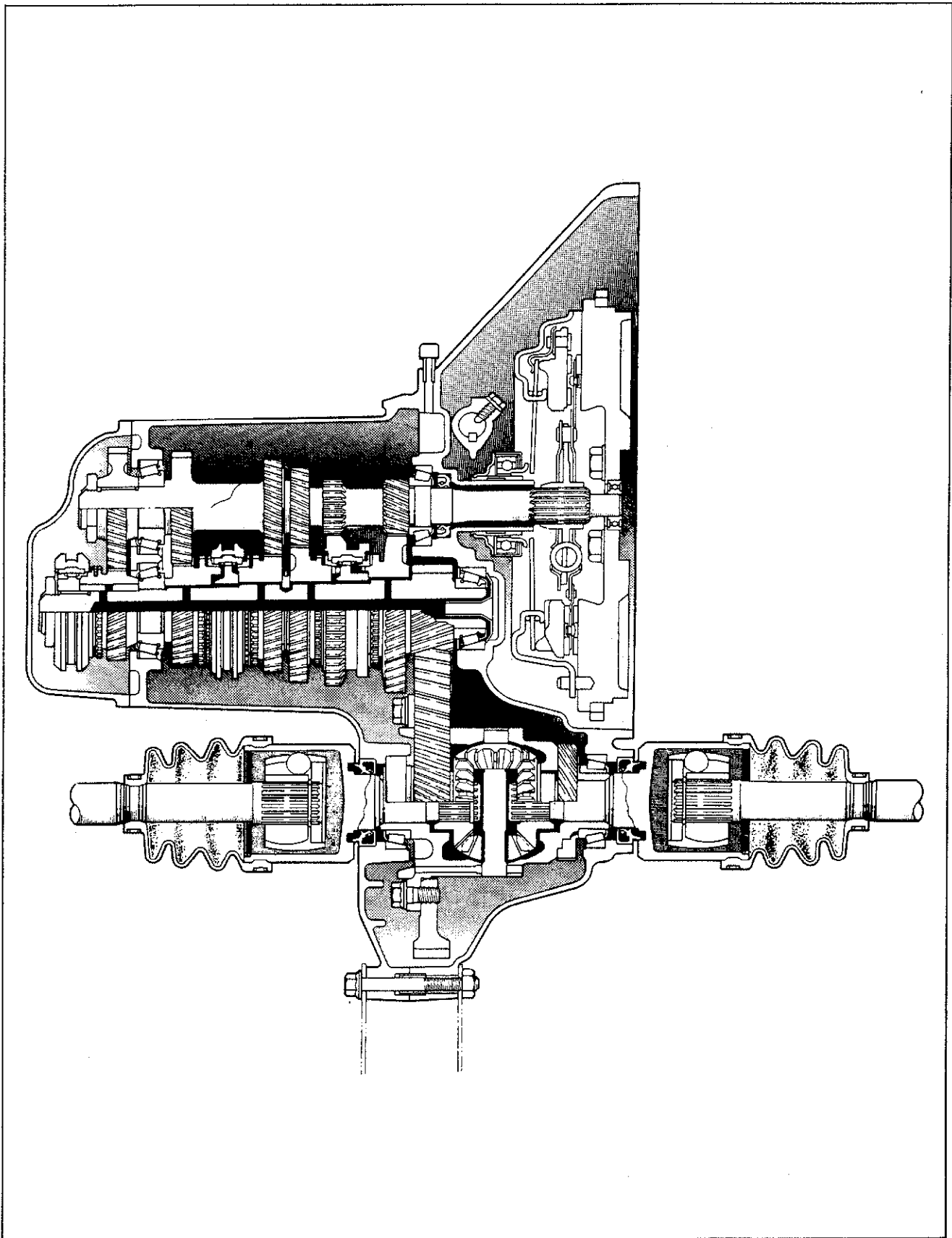

83U07A-003

CROSS-SECTIONAL VIEW (G-type)

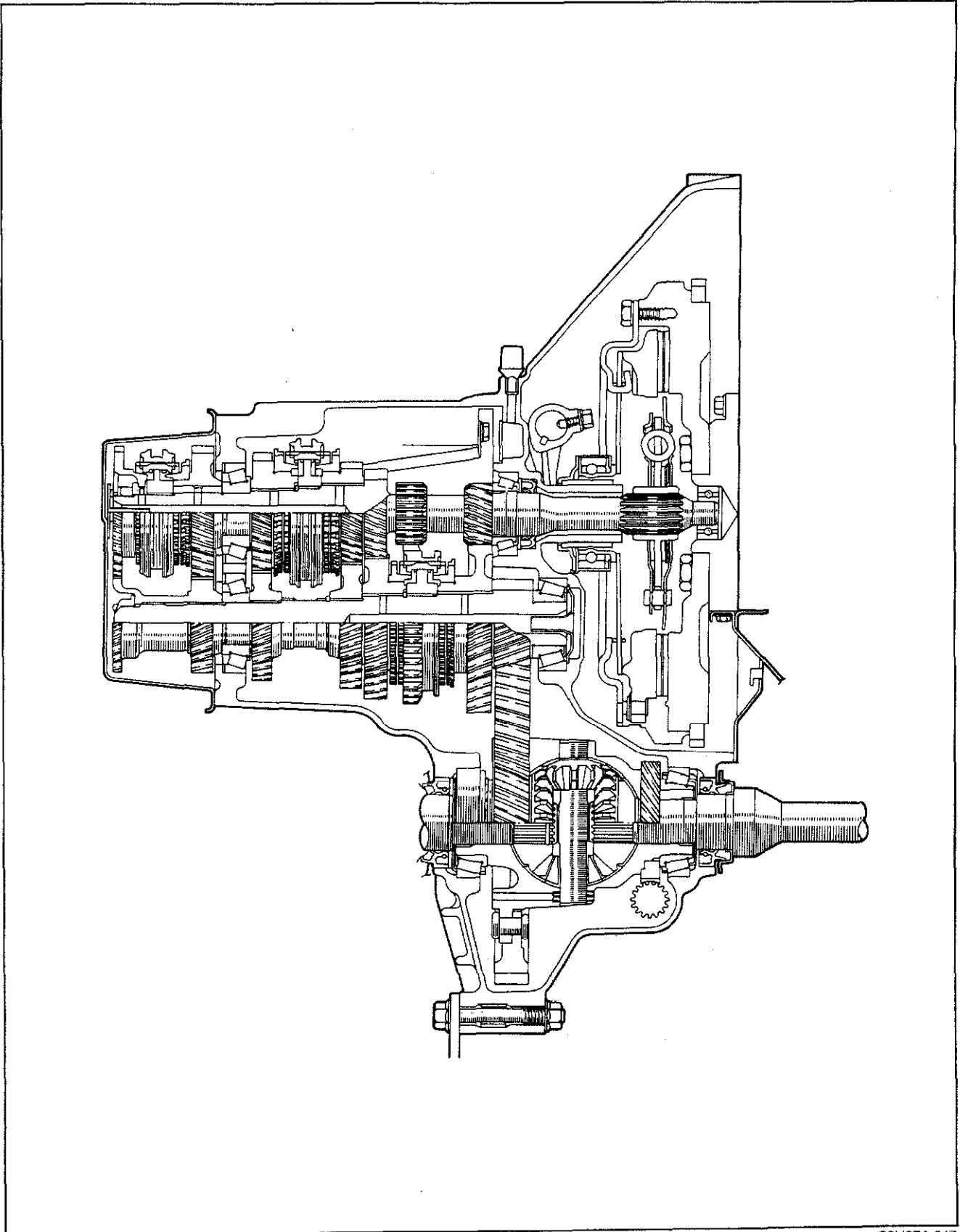

83U07A-047

## SPECIFICATIONS

Item		Transaxle model	F-type (non-turbo)	G-type (turbo)
Transaxle control			Floor shift	
Synchronesh system	Forward		Synchronesh	
	Reverse		Selective sliding	Selective sliding and synchronesh
Gear ratio	First		3.416	3.307
	Second		1.842	1.833
	Third		1.290	1.233
	Fourth		0.918	0.970
	Fifth		0.731	0.795
	Reverse		3.214	3.166
Final gear ratio			4.105	3.850
Speedometer gear ratio			0.88	
Oil	Type		API: GL-4 or GL-5 SAE80W-90 or SAE90 Above -18°C (0°F) ATF: M2C33-F or DEXRON-II	ATF: DEXRON-II  API: GL-4 or GL-5 SAE80W-90 or SAE-90
	Capacity liters (US qt, Imp qt)		3.2 (3.4, 2.8)	3.35 (3.55, 2.96)

83U07A-005

## TROUBLESHOOTING GUIDE

Problem	Probable Cause	Remedy
<b>Change lever won't shift smoothly, or is hard to shift</b>	Seized change lever ball Seized change control rod joint Bent change control rod	Replace Replace Replace
<b>Too much play in change lever</b>	Worn change control rod bushing Weak change lever ball spring Worn change lever ball bushing	Replace Replace Replace
<b>Difficult to shift</b>	Bent change control rod No grease in transaxle control Insufficient oil Deterioration of oil quality  Wear or play of shift fork or shift rod Worn synchronizer ring Worn synchronizer cone of gear Bad contact of synchronizer ring and cone of gear Excessive longitudinal play of gears Worn bearing Worn synchronizer key spring Excessive primary shift gear bearing preload Improperly adjusted change guide plate	Replace Lubricate with grease Add oil Replace with oil of specified quality Replace Replace Replace Replace  Replace Adjust or replace Replace Adjust Adjust
<b>Won't stay in gear</b>	Bent change control rod Worn change control rod bushing Weak change lever ball spring Improperly installed extension bar Worn shift fork Worn clutch hub Worn clutch hub sleeve Worn secondary shaft gear Worn sliding surface of gear Worn steel ball sliding groove of control end Weak spring pressing against steel ball Excessive gear backlash Worn bearing Improperly installed engine mount	Replace Replace Replace Tighten Replace Replace Replace Replace Replace Replace Replace Replace Replace Replace Tighten
<b>Abnormal noise</b>	Insufficient oil Deterioration of oil quality  Worn bearing Worn secondary shaft gear Worn sliding surface of gear Excessive gear backlash Damaged gear teeth Foreign material in gears Damaged differential gear, or excessive backlash	Add oil Replace with oil of specified quality Adjust or replace Replace Replace Replace Replace Replace Replace Repair or replace

83U07A-006

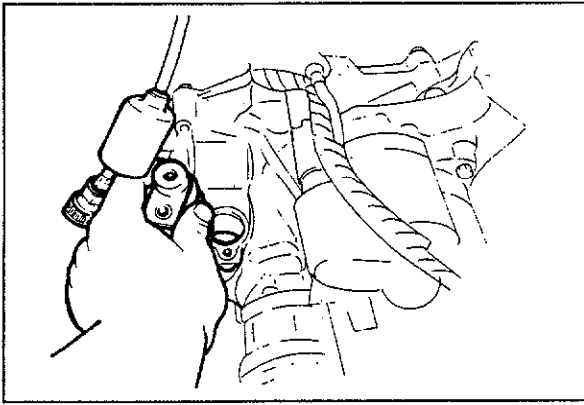

63U07A-006

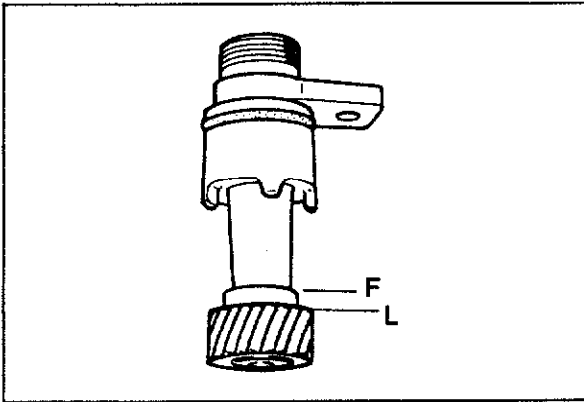

63U07A-007

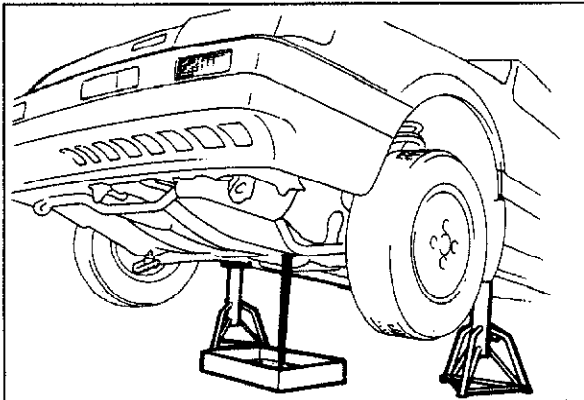

83U07A-007

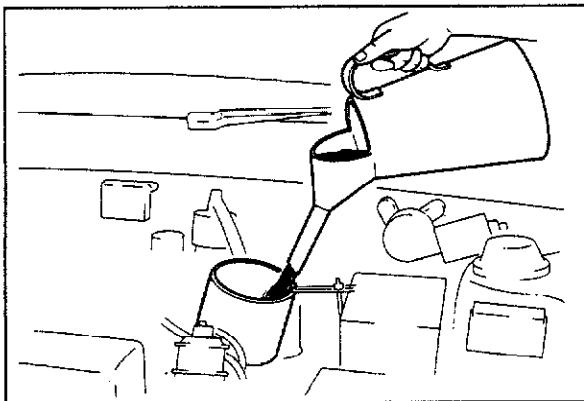

83U07A-008

## ON-VEHICLE MAINTENANCE

### TRANSAXLE OIL

#### Inspection

1. Park the vehicle on a level area.
2. Remove the speedometer cable dust cover, and disconnect the cable from the speedometer driven gear.
3. After removing the bolt, pull the gear case to remove it from the housing. (Insert a flat-tipped screwdriver between the speedometer gear case and the clutch housing, and use it to pry the gear case loose if necessary.)
4. Check whether the oil level is between the "F" and "L".
5. If not, add the necessary amount of the specified oil through the gear case hole.

#### Replacement

1. Park the vehicle on a level area.
2. Remove the speedometer driven gear. (See "Inspection" section above.)
3. Remove the drain plug, and drain the oil.
4. Replace the drain plug, and add the necessary amount of the specified oil through the speedometer gear case hole.

#### Tightening torque :

39—59 N·m (4.0—6.0 m·kg, 29—43 ft·lb)

#### Specified oil

##### Type:

##### F-type MTX

Above -18°C(0°F):

API Service GL-4 or GL-5  
(SAE 90 or 80W-90)

Below -18°C(0°F):

ATF M2C33-F or DEXRON-II.

##### G-type MTX

ATF DEXRON-II

API: GL-4 or GL-5  
SAE80W-90 or SAE 90

#### Capacity:

F-type MTX 3.2 liters  
(3.4 US qt, 2.8 Imp qt)

G-type MTX 3.35 liters  
(3.55 US qt, 2.96 Imp qt)

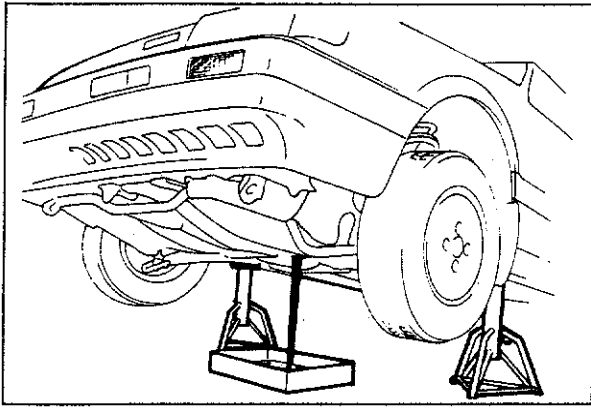

63U07A-010

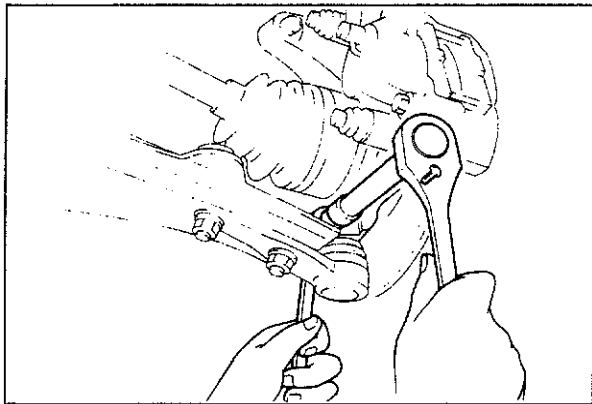

63U07A-011

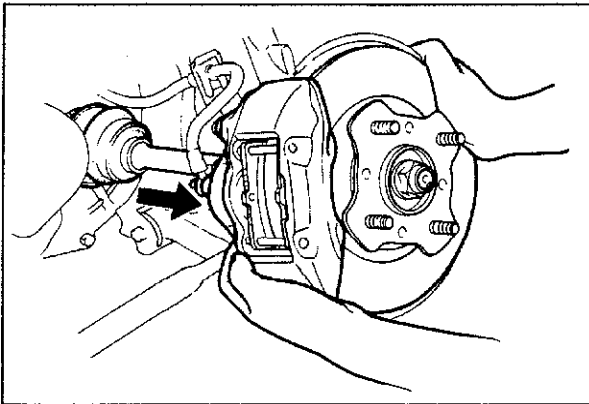

63U07A-012

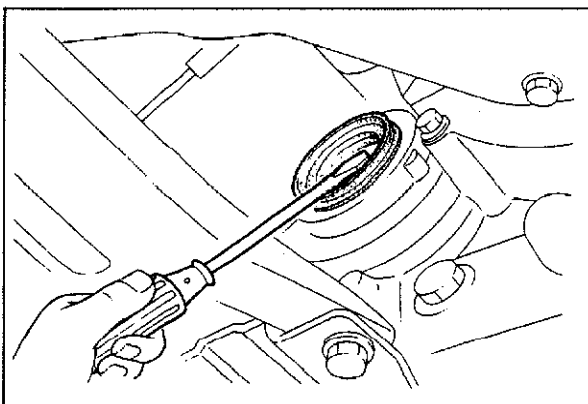

63U07A-013

## DRIVESHAFT OIL SEALS

### Replacement

Jack up the vehicle, support it on safety stands, and then drain the transaxle oil. Next, use the following procedure to replace the driveshaft oil seals:

1. Remove the front wheel(s).
2. Remove the undercover.
3. Remove the side cover.
4. Separate the front stabilizer from the lower arm.

5. Remove the clinch bolt and pull the lower arm downward. Separate the knuckle from the lower arm.

### Caution

**Be careful not to damage the ball joint dust boot.**

6. Separate the driveshaft by pulling the front hub outward. Make sure not to use too much force at once, increase the force gradually.

### Note

- a) **Make sure not to allow the drive shaft ball joint to be bent to its maximum extent.**
- b) **Support the driveshaft using string, wire etc.**

7. Remove the oil seal with a flat-tipped screwdriver.

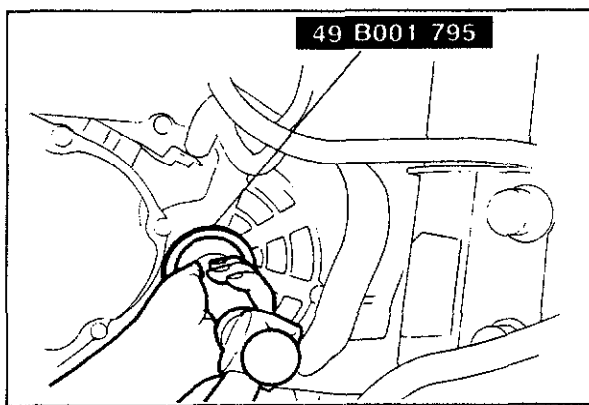

83U07A-048

8. Tap the new oil seal into the transaxle case with the **SST**.

**Caution**

- a) Tap in until the oil seal installer contacts the case.
- b) Coat the oil seal lip with transaxle oil.

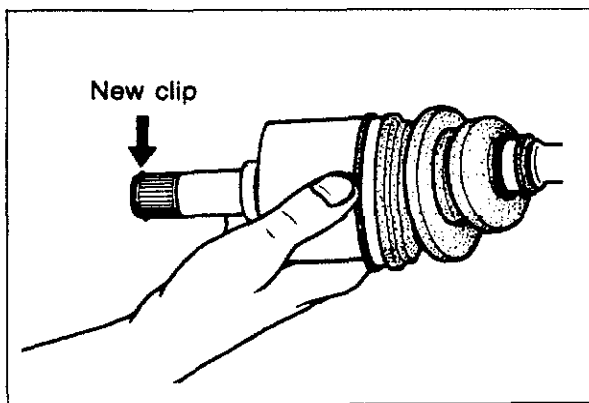

63U07A-015

9. Replace the driveshaft end clip with a new one. Insert the clip with the gap at the top of the groove.

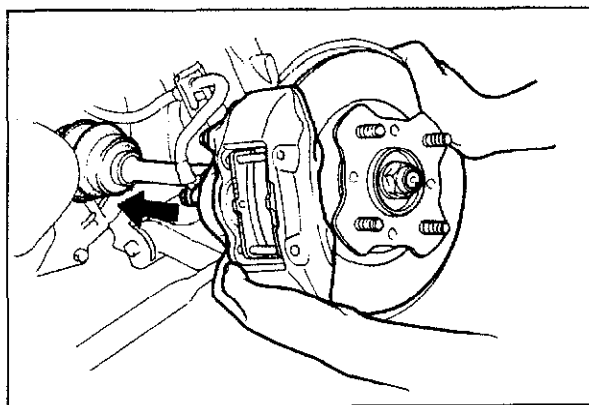

63U07A-016

10. Install the driveshaft, as follows:
- (1) Pull the front hub outward, and then fit the driveshaft into the transaxle.
  - (2) Insert the driveshaft into the transaxle by pushing on the wheel hub assembly.

**Caution**

- a) Be careful not to damage the oil seal.
- b) After installation is finished, pull the front hub slowly outward to check that the driveshaft is held securely by the clip.

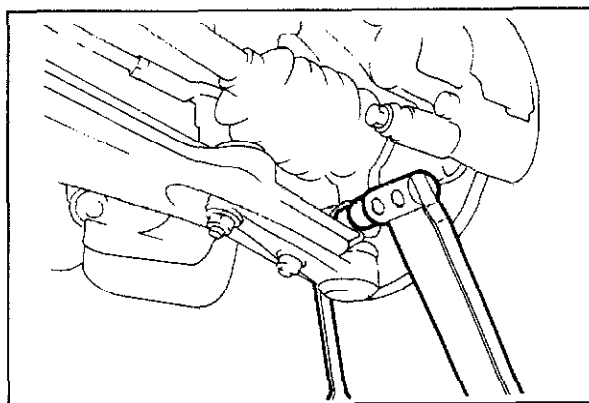

63U07A-017

11. Install the lower arm ball joint to the knuckle, and tighten the clinch bolt.

**Tightening torque:**

**43—54 N·m (4.4—5.5 m·kg, 32—40 ft·lb)**



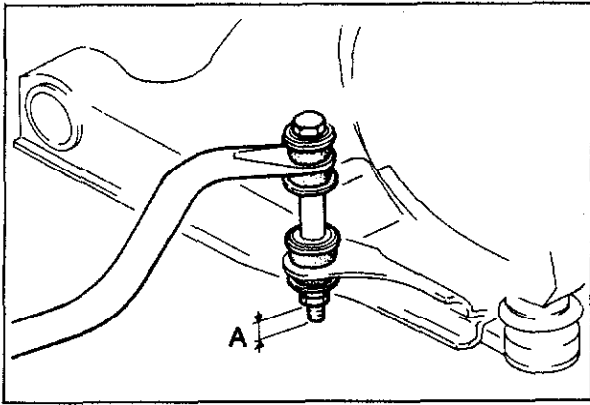

63U07A-018

12. Adjust and tighten the front stabilizer bolt.

**Tightening torque:**

**12—18 N·m (1.2—1.8 m·kg, 9—13 ft·lb)**

**Dimension A:**

**10.8 mm (0.43 in)**

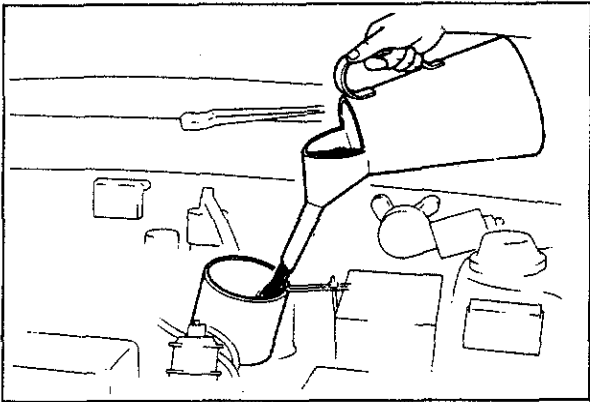

63U07A-019

13. Install the side cover.

14. Install the undercover.

15. Mount the front wheel(s).

16. Remove the safety stands.

17. Add the correct quantity of the specified transaxle oil.

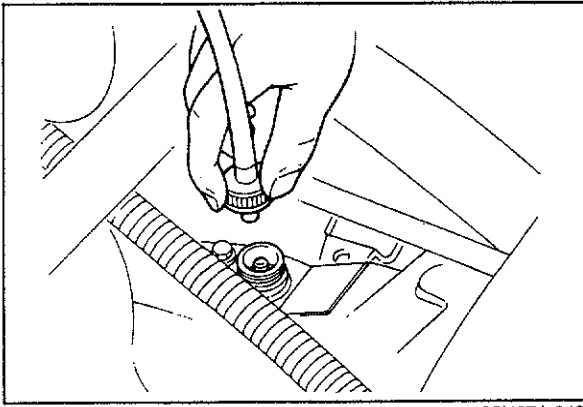

83U07A-049

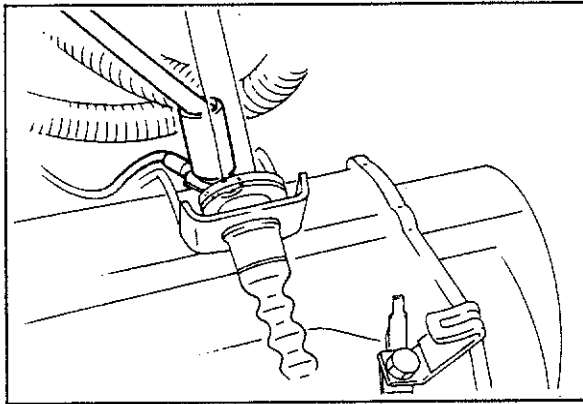

63U07A-021

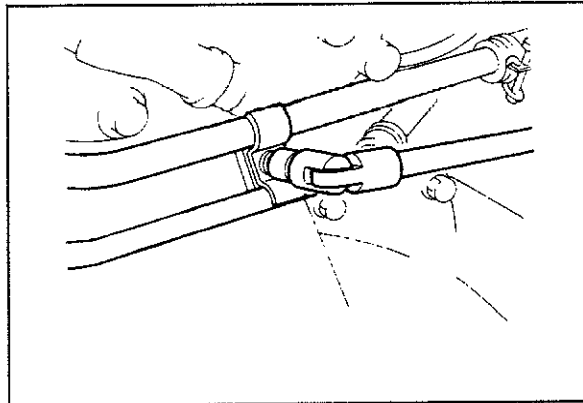

63U07A-022

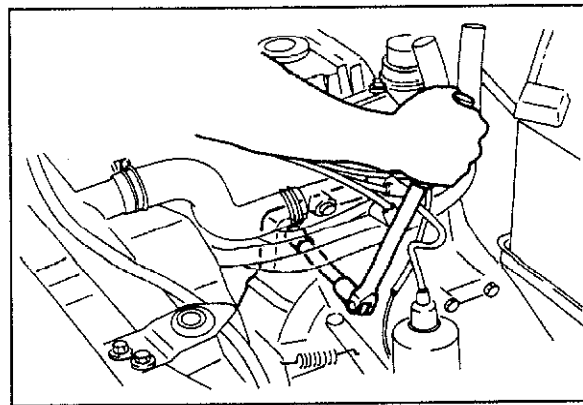

83U07A-050

## REMOVAL

1. Disconnect the battery negative cable.
2. Remove the air cleaner.
3. Loosen the front wheel lug nuts.
4. Disconnect the speedometer cable from the transaxle.
5. Disconnect the clutch cable from the release lever, and remove the clutch cable bracket mounting bolts.
6. Remove the ground wire installation bolt.
7. Remove water pipe bracket.
8. Remove the secondary air pipe and E.G.R. pipe bracket.
9. Remove the wire harness clip.
10. Disconnect the coupler for the neutral switch and the back-up light switch.
11. Disconnect the body ground connector.
12. Remove the two upper transaxle to engine mounting bolts.

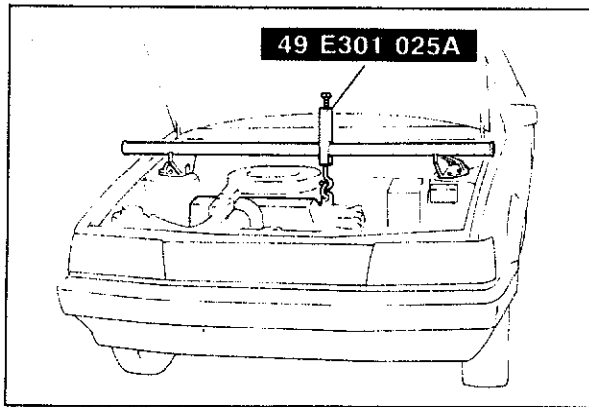

83U07A-051

13. Mount the **SST** to the engine hanger.
14. Jack up the vehicle and support it with safety stands at the specified positions.
15. Drain the transaxle oil.
16. Remove the front wheels.
17. Remove the undercover and side covers.
18. Remove the front stabilizer.

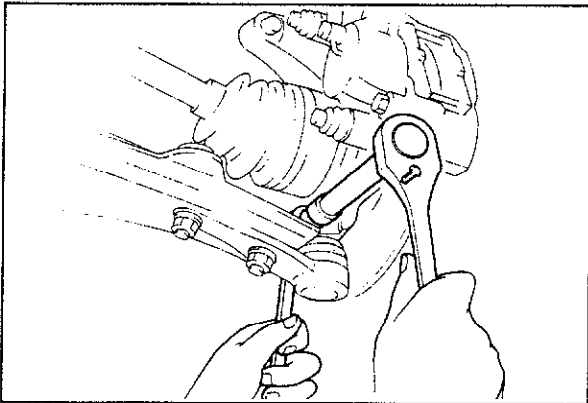

63U07A-025

19. Remove the lower arm ball joints and the knuckle clinch bolts, pull the lower arms downward, and separate the lower arms from the knuckles.

**Caution**

**Be careful not to damage the ball joint dust boot.**

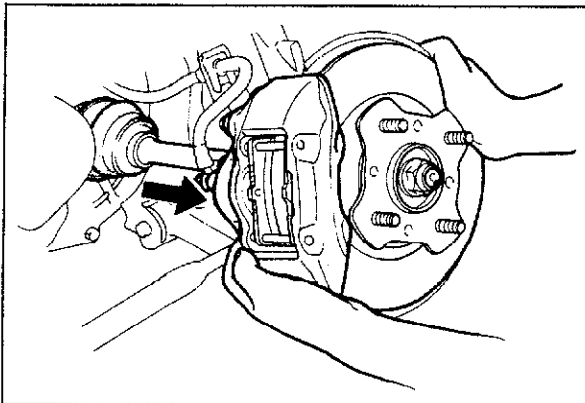

63U07A-026

20. Separate the driveshaft by pulling the front hub outward. Make sure not to use too much force at once, increase the force gradually.

**Note**

- a) Make sure not to allow the driveshaft ball joint to be bent to its maximum extent.
- b) Support the driveshaft using wire, string etc.

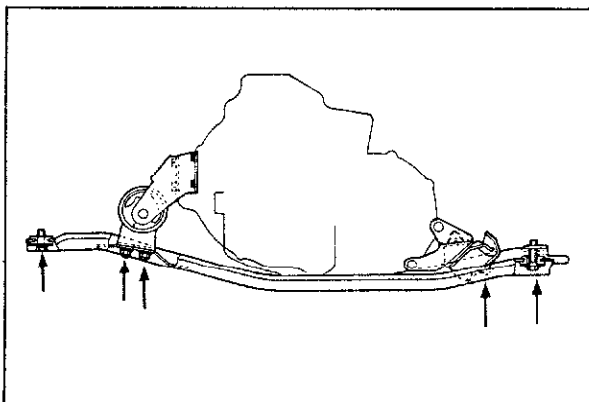

63U07A-027

21. Remove the crossmember.

# 7A REMOVAL

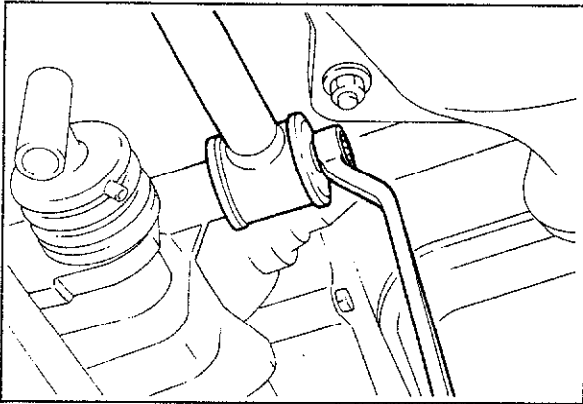

63U07A-028

22. Separate the change control rod from the transaxle.
23. Remove the extension bar from the transaxle.
24. Remove the wires from the starter motor, and remove the starter motor.

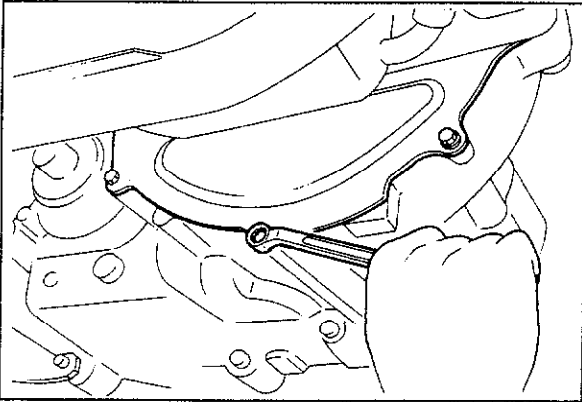

63U07A-029

25. Remove the end plate.
26. Lean the engine toward the transaxle side by loosening the engine support hook bolt.

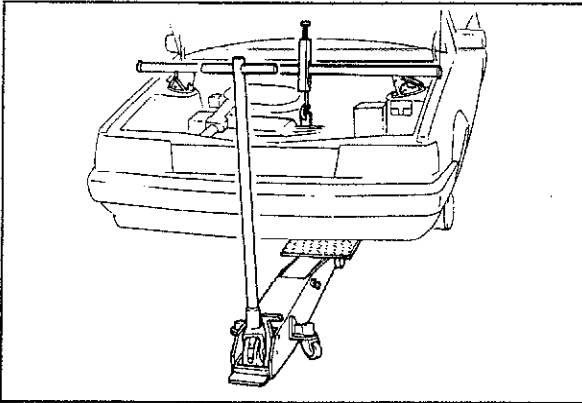

63U07A-030

27. Support the transaxle with a jack.

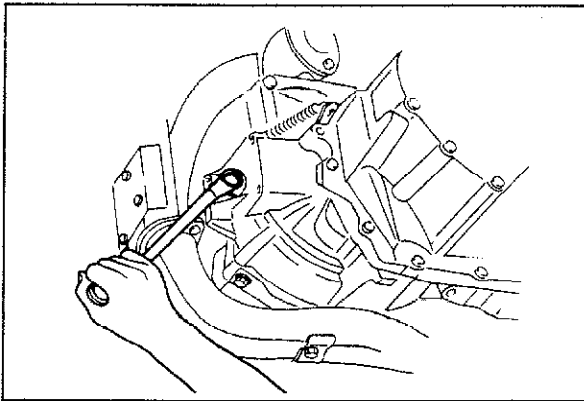

63U07A-031

28. Remove the No. 2 engine bracket.
29. Remove the remaining transaxle mounting bolts.
30. Remove the transaxle.

## [F-type] DISASSEMBLY

### DISASSEMBLY-STEP 1

Disassemble in the numbered order shown in the figure.

#### Note

1—11 apply to 5 speed only. (Commence disassembly of 4 speed by removing transaxle case.)

83U07A-052

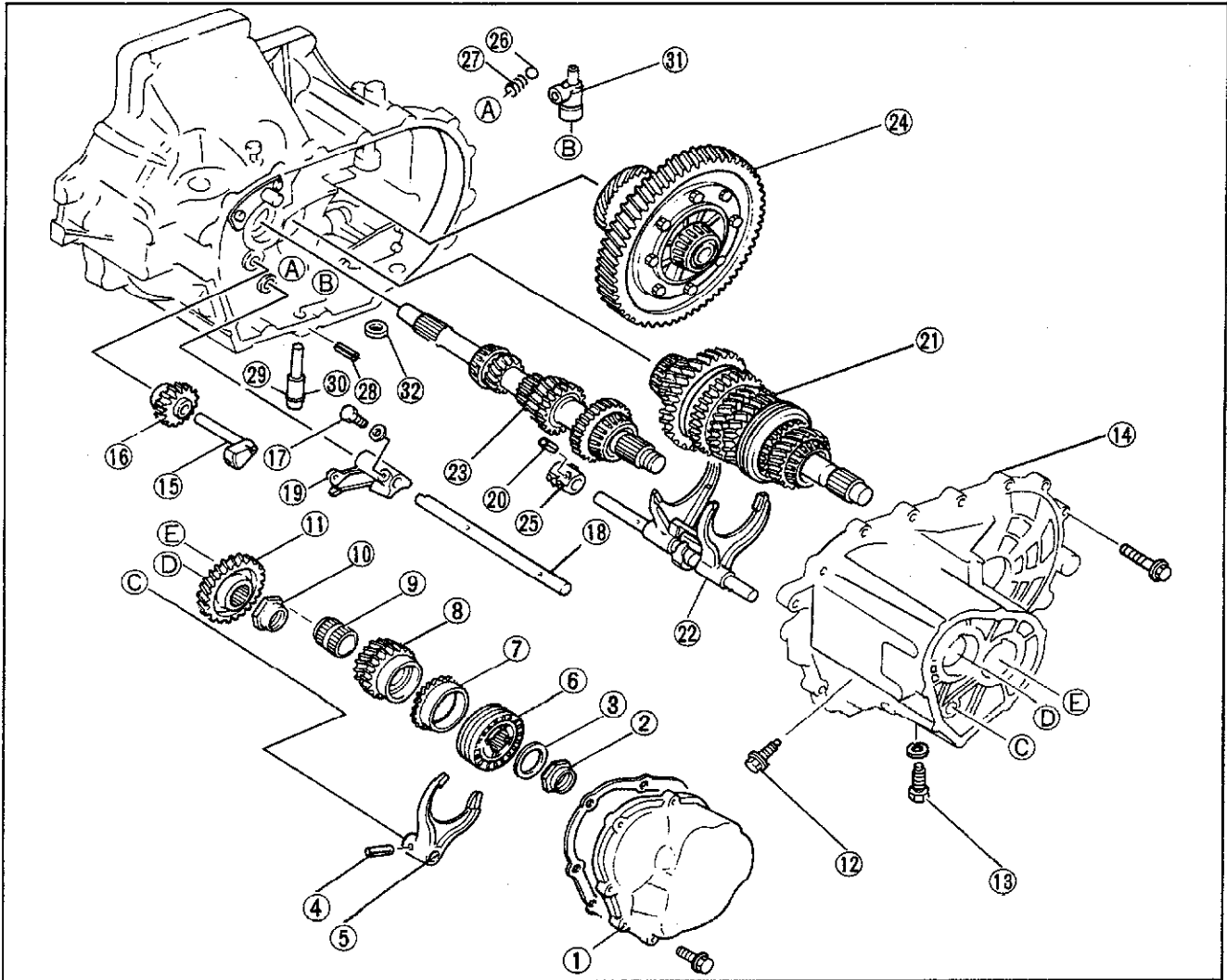

63U07A-033

- |                        |                                   |                                 |
|------------------------|-----------------------------------|---------------------------------|
| 1. Rear cover          | 12. Lock bolt                     | 22. Shift fork assembly         |
| 2. Lock nut            | 13. Guide bolt                    | 23. Primary shaft gear assembly |
| 3. Stopper plate       | 14. Transaxle case                | 24. Differential assembly       |
| 4. Spring pin          | 15. Reverse idle shaft            | 25. Control end                 |
| 5. Shift fork          | 16. Reverse idle gear             | 26. Steel ball                  |
| 6. Clutch hub assembly | 17. Lock bolt                     | 27. Spring                      |
| 7. Synchronizer ring   | 18. Shift rod (5th and reverse)   | 28. Spring pin                  |
| 8. 5th gear            | 19. Gate                          | 29. Crank lever shaft           |
| 9. Gear sleeve         | 20. Spring pin                    | 30. O-ring                      |
| 10. Lock nut           | 21. Secondary shaft gear assembly | 31. Crank lever assembly        |
| 11. Primary gear       |                                   | 32. Magnet                      |

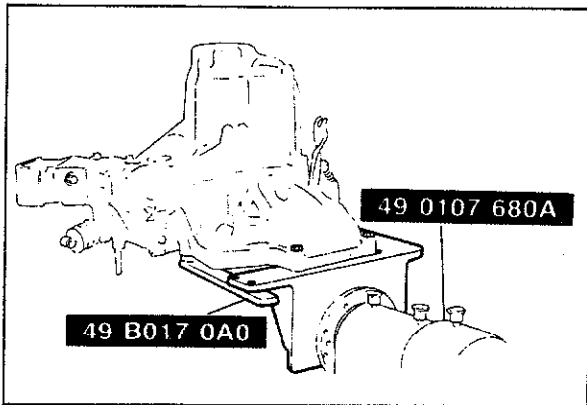

83U07A-053

## Transaxle

Position the **SST**, and mount the transaxle on the hanger.

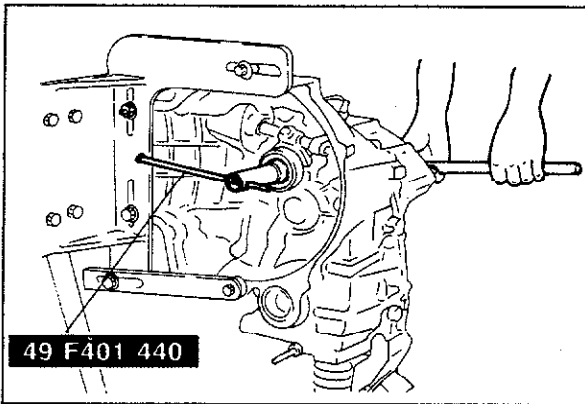

83U07A-054

## Lock Nut

Lock the primary shaft with the **SST**, and remove the lock nut.

## Note

**Shift to 1st or 2nd.**

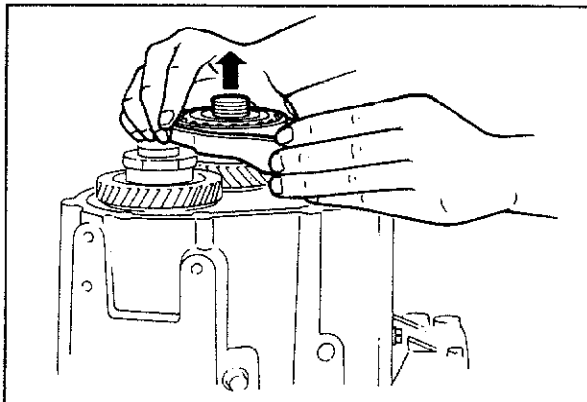

63U07A-036

## Shift Fork (5th)

Remove the shift fork (5th) together with the clutch hub assembly.

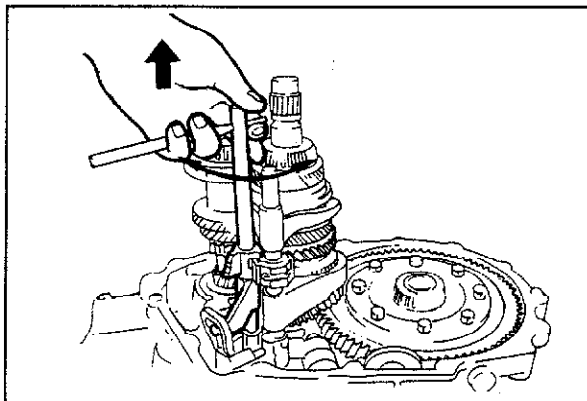

63U07A-037

## Shift rod (5th and reverse)

1. Insert a pin punch or suitable rod into the spring pin hole of the shift rod.
2. Pull out the shift rod while turning the pin punch or the rod (5 speed).

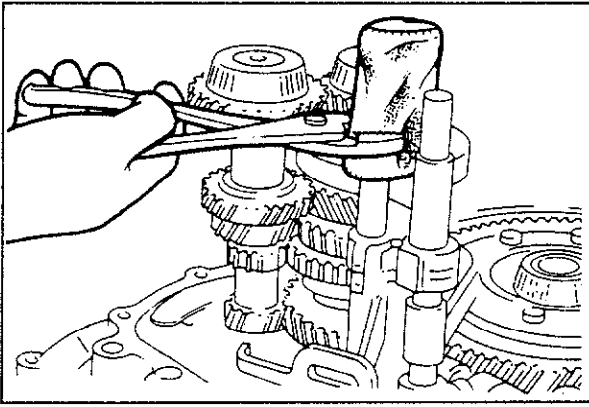

73U07A-505

### Reverse Shift Rod

To remove the reverse shift rod, wrap it with a cloth and turn it with pliers while pulling out.

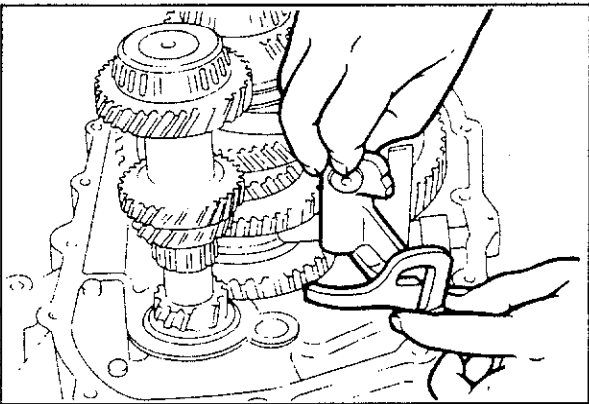

73U07A-506

### Gate

Remove the gate by lifting it out together with the reverse lever.

### Note

**Before removing the gate, place the transaxle in neutral.**

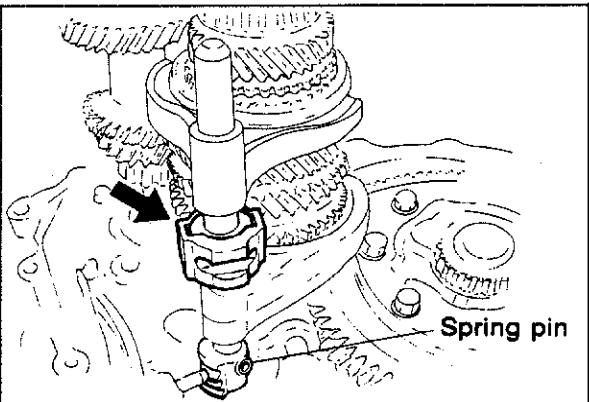

63U07A-040

### Spring Pin

The spring pin used for attaching the control rod and control end can easily be removed by the following procedure:

1. Make sure the transaxle is in neutral and the interlock sleeve and control lever are in the position as shown in the figure.

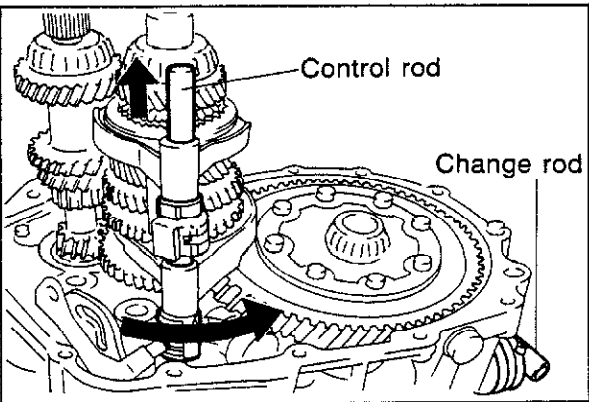

63U07A-041

2. Move the change rod to turn the control rod counter clockwise.
3. Hold the change rod in the turned position and push inward on it to raise the control rod upward.

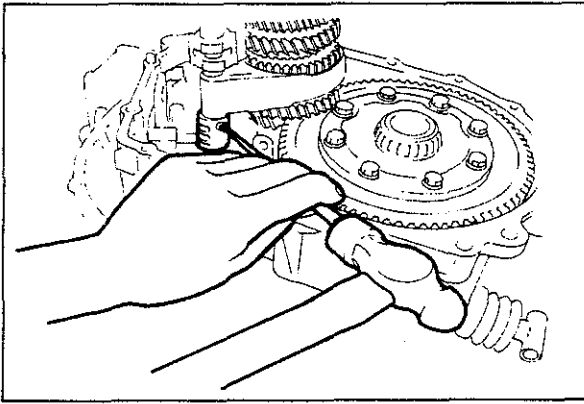

63U07A-042

4. Remove the spring pin with a pin punch.

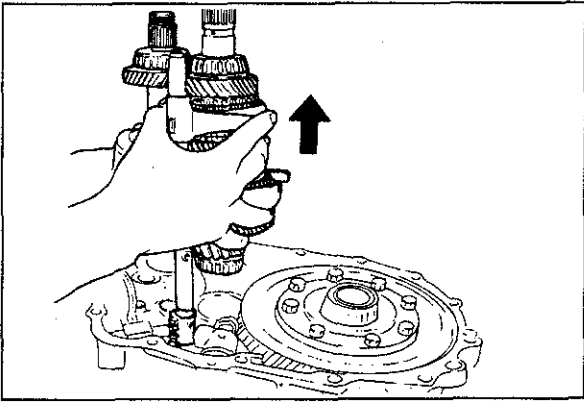

63U07A-043

### Primary Shaft Gear Assembly, Secondary Shaft Gear Assembly and Shift Fork Assembly

Lift the primary shaft, secondary shaft and shift fork assemblies out as a unit.

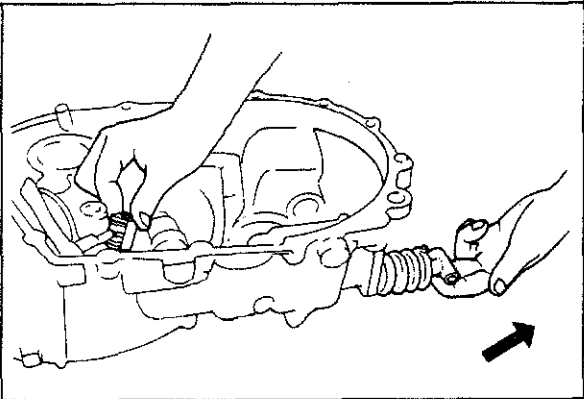

63U07A-044

### Control End

Pull the change rod rearward and remove the control end and ball and spring.

### Caution

Be careful not to lose the ball and spring.

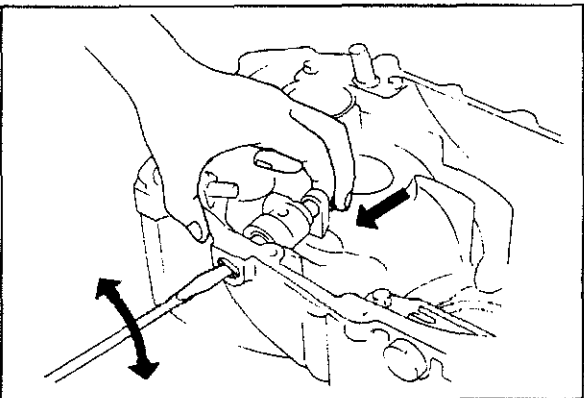

63U07A-045

### Crank Lever Shaft

Turn the lever with a screwdriver while pushing the lever out of the housing, and remove.



**DISASSEMBLY-STEP 2**

Disassemble in the numbered order shown in the figure.

**Note**

10, 11, and 25 are for 5 speed only.

63U07A-046

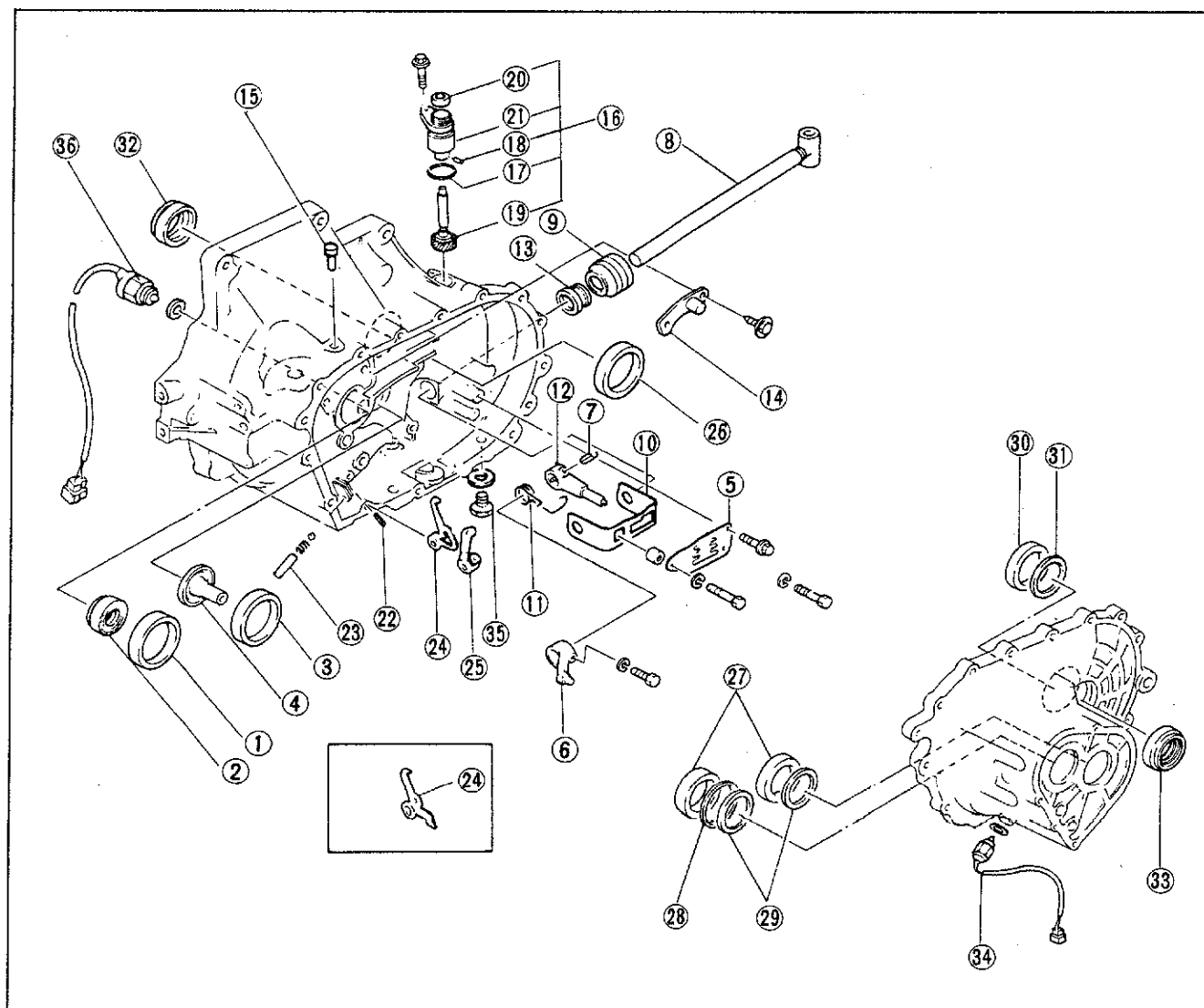

63U07A-047

- |                       |                                      |                          |
|-----------------------|--------------------------------------|--------------------------|
| 1. Bearing outer race | 13. Oil seal                         | 25. Lever set spring     |
| 2. Oil seal           | 14. Breather cover                   | 26. Bearing outer race   |
| 3. Bearing outer race | 15. Breather                         | 27. Bearing outer race   |
| 4. Funnel             | 16. Speedometer driven gear assembly | 28. Diaphragm spring     |
| 5. Guide plate        | 17. O-ring                           | 29. Adjustment shim      |
| 6. Change arm         | 18. Spring pin                       | 30. Bearing outer race   |
| 7. Spring pin         | 19. Driven gear                      | 31. Adjustment shim      |
| 8. Change rod         | 20. Oil seal                         | 32. Oil seal             |
| 9. Boot               | 21. Gear case                        | 33. Oil seal             |
| 10. Reverse gate      | 22. Spring pin                       | 34. Back-up light switch |
| 11. Spring            | 23. Reverse lever shaft              | 35. Drain plug           |
| 12. Selector          | 24. Reverse lever                    | 36. Neutral switch       |

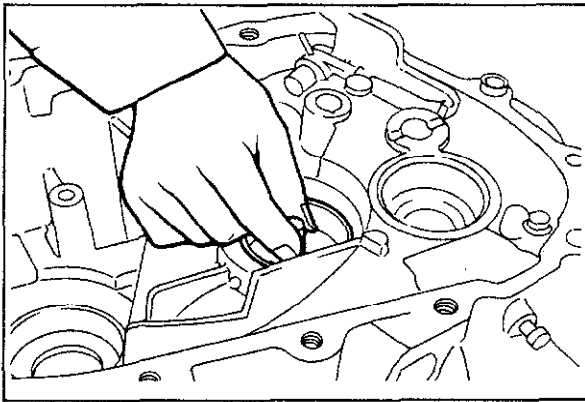

63U07A-048

### Bearing Outer Race (secondary shaft gear)

Remove the bearing outer race by lifting the funnel and the race out together.

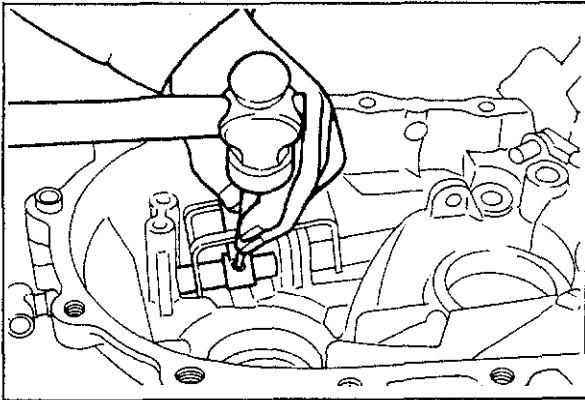

63U07A-049

### Spring pin

For removing the selector attaching pin, match the pin's position with the removing groove, then tap the pin out with a pin punch and hammer.

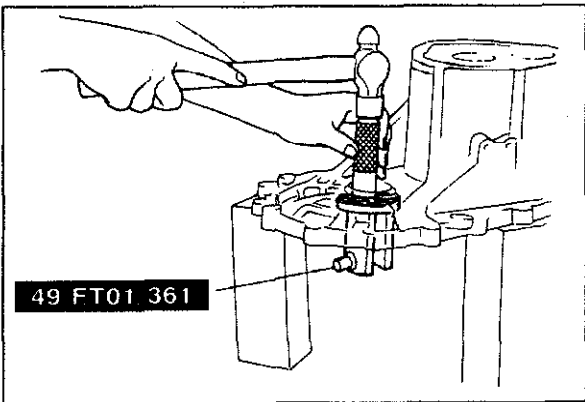

83U07A-055

### Bearing Outer Race (differential, clutch housing and transaxle case)

Remove the bearing outer races with the **SST** and hammer. Do not remove the oil seals, unless replacement is necessary due to damage.

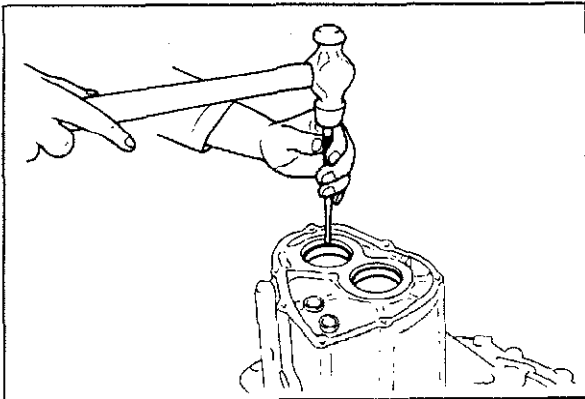

63U07A-051

### Bearing Outer Race (5th gear, transaxle case)

Remove both of the bearing outer races with a brass rod positioned on the race by means of the grooves in the case.

### Note

**Remove the races gradually and evenly.**

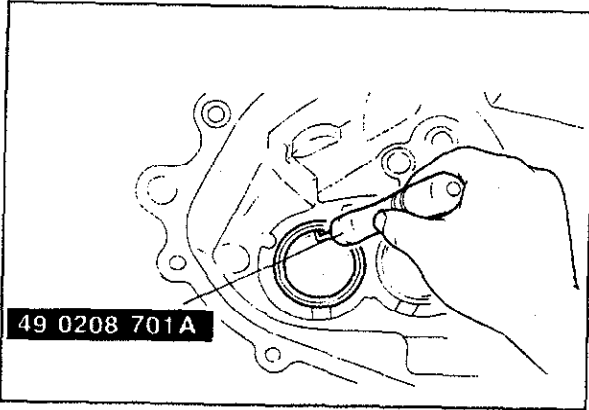

83U07A-056

**Bearing Outer Race (4th gear, transaxle case)**  
Remove the bearing outer races gradually with the **SST** or a screwdriver with a bent end.

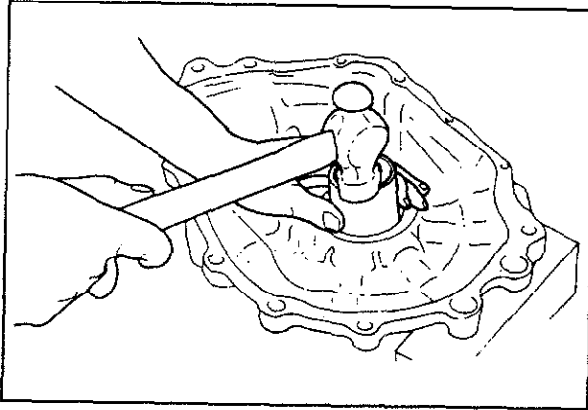

83U07A-053

**Oil Seal (differential)**

Check the oil seals and if necessary replace them. Use a pipe of the proper size to tap the seal out.

**Note**

**Remove the oil seal gradually and evenly.**

## DISASSEMBLY-STEP 3

Disassemble in the numbered order shown in the figure.

### Note

a) 35—39 are for 5 speed only.

b) Do not disassemble the bearing inner races (except the 4th gear end (10) of the secondary shaft gear assembly) unless necessary. Replace them with new races whenever they are disassembled.

c) Before disassembly, check the thrust clearance of all gears. (Refer to page 7A—34)

83U07A-057

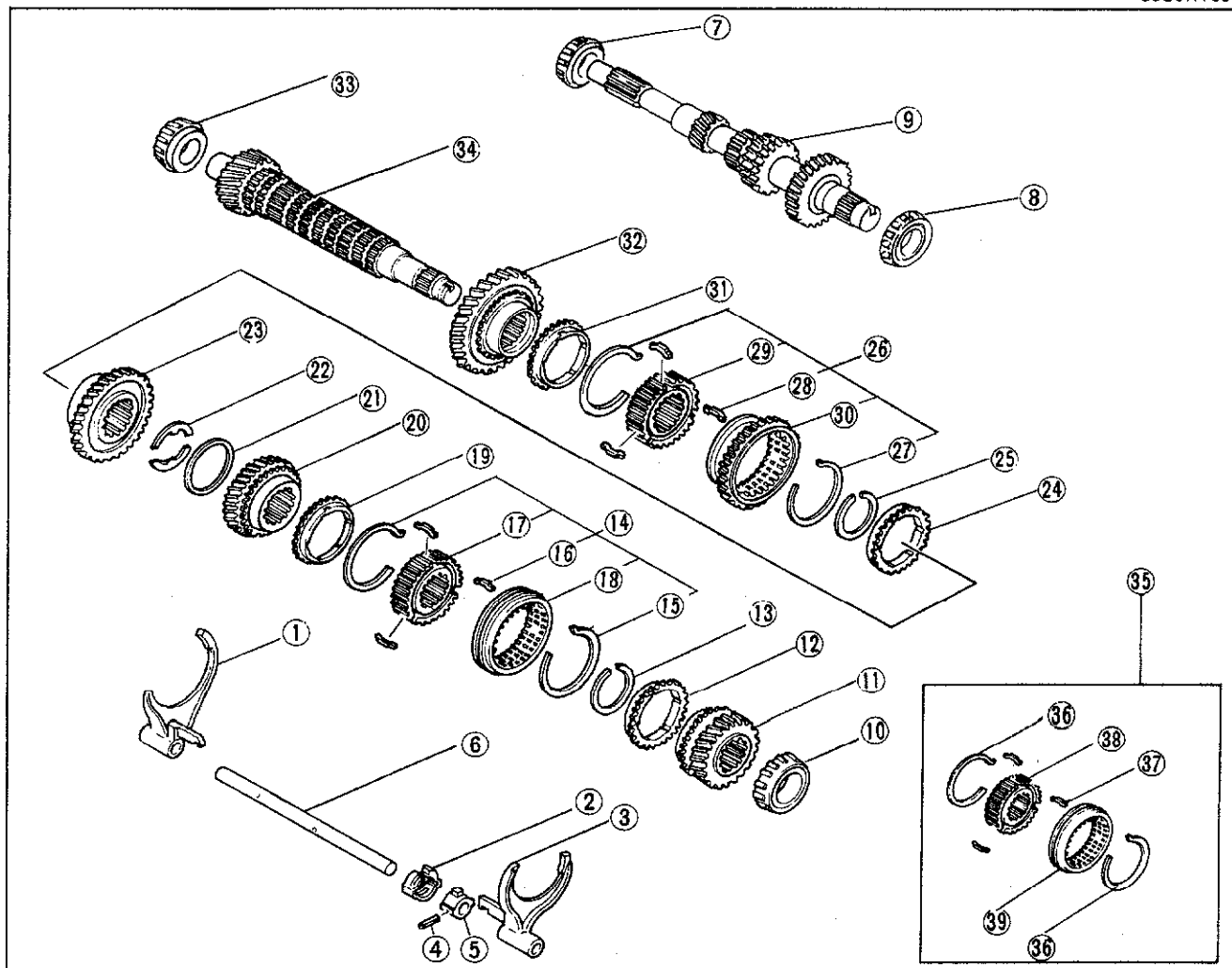

63U07A-055

- |                                 |   |                                      |
|---------------------------------|---|--------------------------------------|
| 1. Shift fork (1st - 2nd gears) | 14. Clutch hub assembly (3rd - 4th gears) | 27. Synchronizer spring              |
| 2. Interlock sleeve             | 15. Synchronizer spring                   | 28. Synchronizer key                 |
| 3. Shift fork (3rd - 4th gears) | 16. Synchronizer key                      | 29. Clutch hub                       |
| 4. Spring pin                   | 17. Clutch hub                            | 30. Clutch hub sleeve (reverse gear) |
| 5. Control lever                | 18. Clutch hub sleeve                     | 31. Synchronizer ring                |
| 6. Control rod                  | 19. Synchronizer ring                     | 32. 1st gear                         |
| 7. Bearing inner race           | 20. 3rd gear                              | 33. Bearing inner race               |
| 8. Bearing inner race           | 21. Ring                                  | 34. Secondary shaft gear             |
| 9. Primary shaft gear           | 22. Thrust washer                         | 35. Clutch hub assembly (5th gear)   |
| 10. Bearing inner race          | 23. 2nd gear                              | 36. Synchronizer spring              |
| 11. 4th gear                    | 24. Synchronizer ring                     | 37. Synchronizer key                 |
| 12. Synchronizer ring           | 25. Retaining ring                        | 38. Clutch hub                       |
| 13. Retaining ring              | 26. Clutch hub assembly (1st - 2nd gears) | 39. Clutch hub sleeve                |

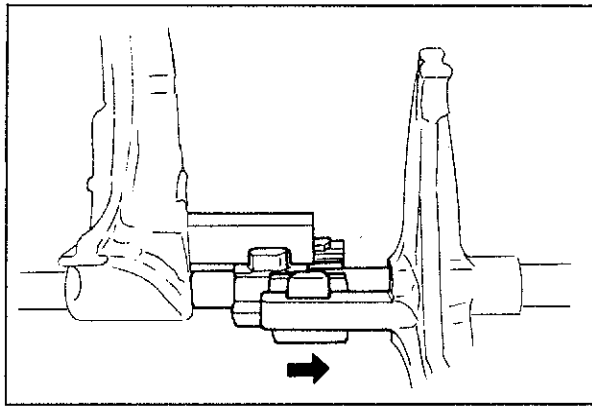

83U07A-056

### Shift Fork Assembly

Disassemble the 1st - 2nd shift fork, interlock sleeve and 3rd - 4th shift fork after setting them as shown in the figure. Slide the 3rd - 4th shift fork and interlock sleeve off the shaft.

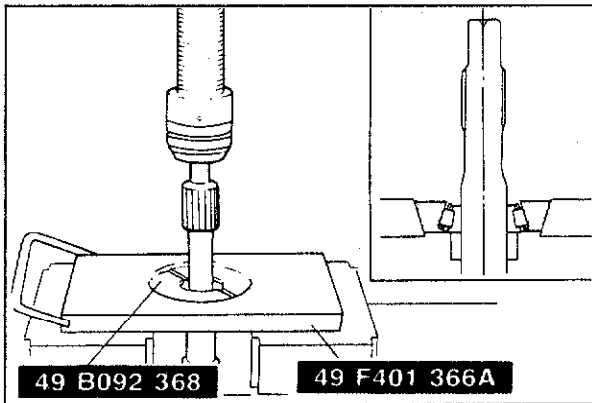

83U07A-058

### Bearing Inner Race (1st gear end of primary shaft gear)

Press the bearing inner race from the shaft with the SST.

**Caution**  
Hold the shaft with one hand so that it does not fall.

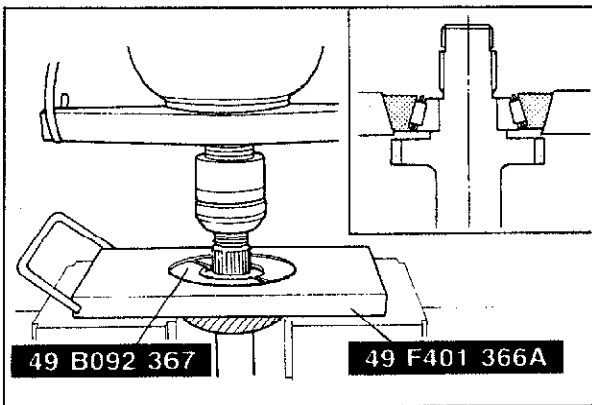

83U07A-059

### Bearing Inner Race (4th gear end of primary shaft gear)

Press the bearing inner race from the shaft with the SST.

**Caution**  
Hold the shaft with one hand so that it does not fall.

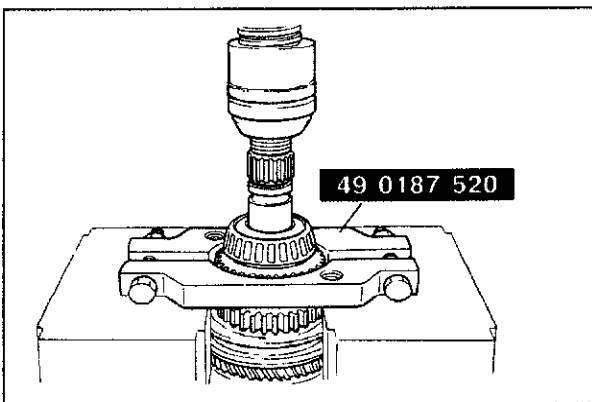

83U07A-060

### Bearing Inner Race and 4th Gear (secondary shaft gear assembly)

Remove the bearing inner race and the 4th gear with the SST.

Piston the puller between the two sets of gear teeth on the 4th gear.

**Caution**  
Hold the shaft with one hand so that it does not fall.

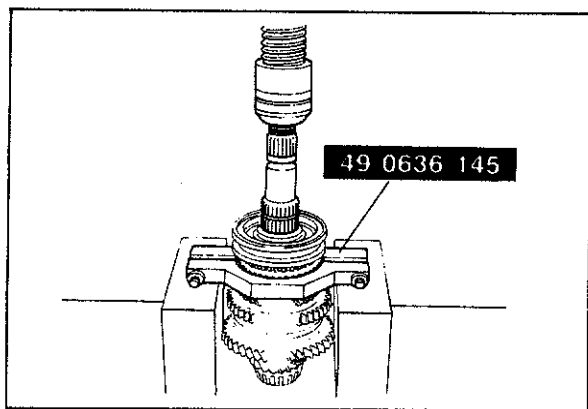

83U07A-061

### Clutch Hub Assembly (3rd - 4th gear)

Set the **SST** onto the 3rd gear, between the two sets of teeth, and then, by using a press, remove the clutch hub assembly together with the gear.

#### Caution

Hold the shaft with one hand so that it does not fall.

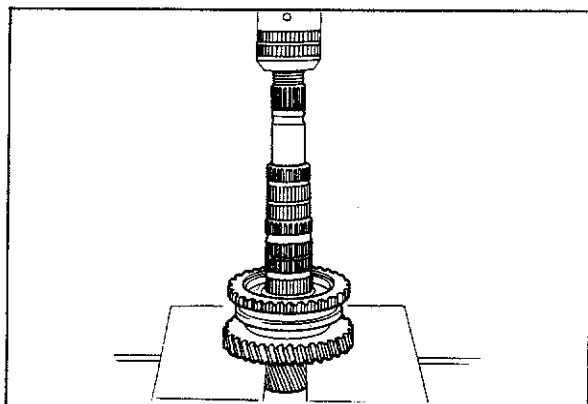

63U07A-071

### Clutch Hub Assembly (1st - 2nd gear)

Support the 1st gear and press it and the clutch hub assembly off the secondary shaft.

#### Caution

Hold the shaft with one hand so that it does not fall.

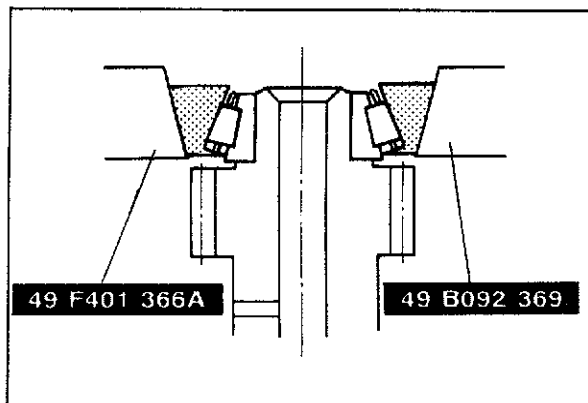

83U07A-062

### Bearing Inner Race (drive pinion end of secondary shaft gear)

Remove the bearing inner race from the shaft with the **SST**.

#### Caution

Hold the shaft with one hand so that it does not fall.

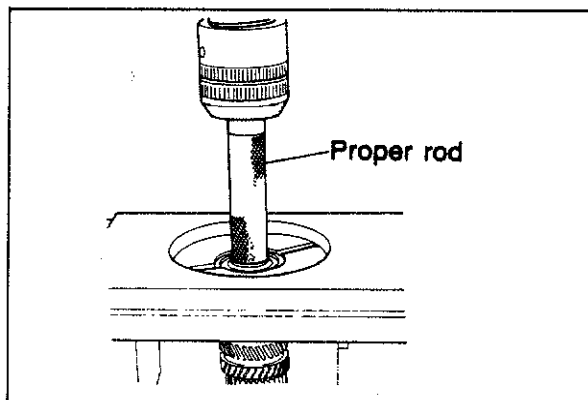

63U07A-900

**DIFFERENTIAL**

Disassemble the differential in the numbered order shown in the figure.

**Caution**

If any of the bearing inner races are removed (with bearing remover) replace with a new one.

63U07A-060

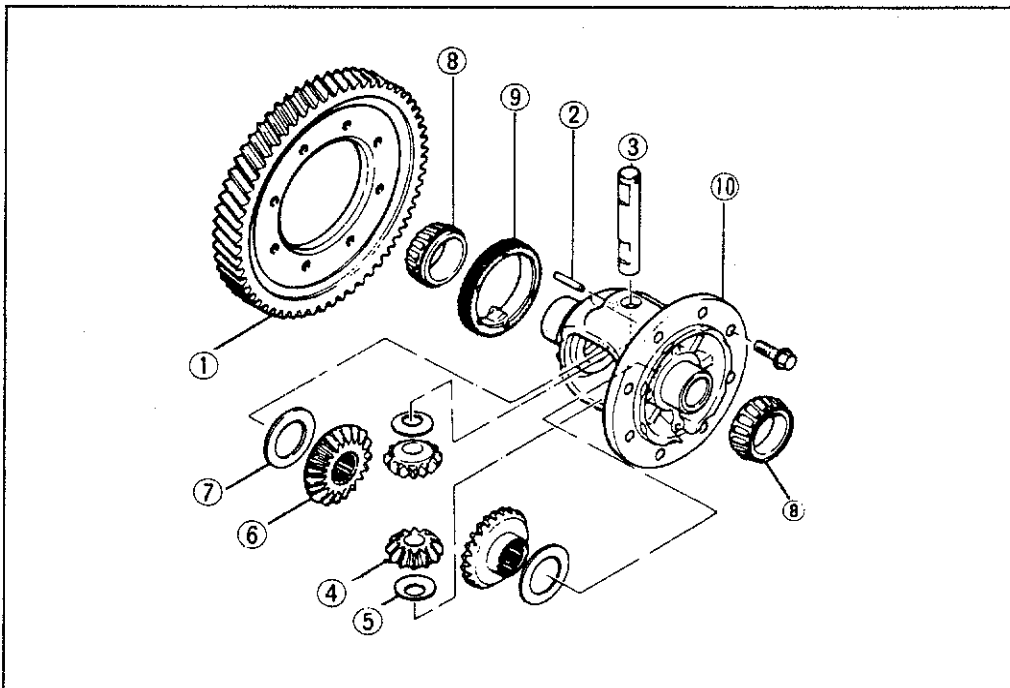

63U07A-061

1. Ring gear
2. Knock-pin
3. Pinion shaft
4. Pinion gear
5. Thrust washer
6. Side gear
7. Thrust washer
8. Side bearing inner race
9. Speedometer drive gear
10. Gear case

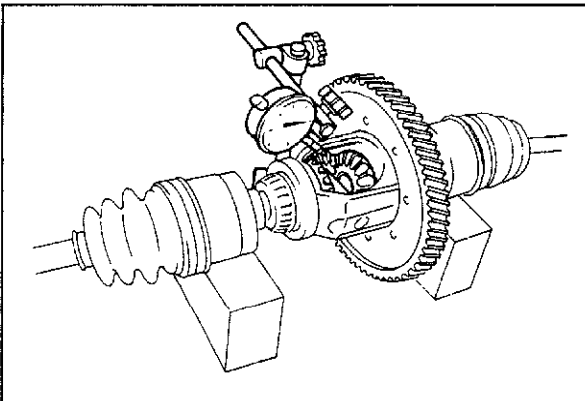

83U07A-063

**Backlash**

Before disassembly, check the backlash of side gears and pinion gears. (Refer to page 7A—31)

**Standard backlash: 0—0.1 mm (0—0.004 in)**

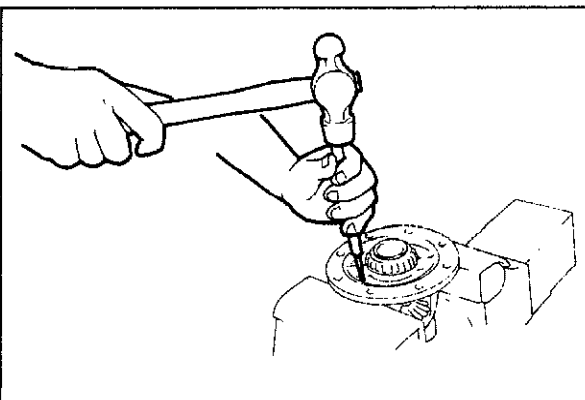

73U07A-510

**Knock-pin**

To remove the knock-pin from the pinion shaft, place the gear case on a vise and knock the pin out with a 4 mm diameter rod, and hammer.

**Note**

Insert the rod into the knock-pin hole from the ring gear mounting surface side.

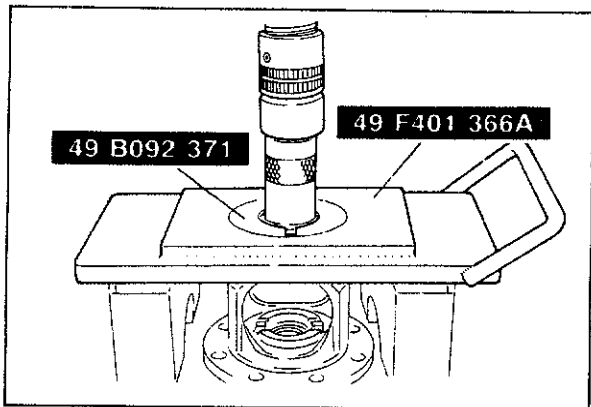

83U07A-064

### Side Bearing Inner Race (side opposite the ring gear)

Remove the bearing inner race from the gear case by using the **SST**.

#### Caution

**Hold the gear case with one hand so that it does not fall.**

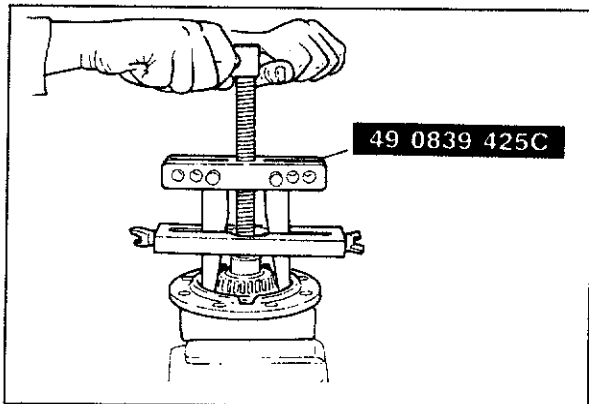

83U07A-065

### Side Bearing Inner Race (ring gear side)

Remove the side bearing inner race by using a combination of parts from the **SST**.

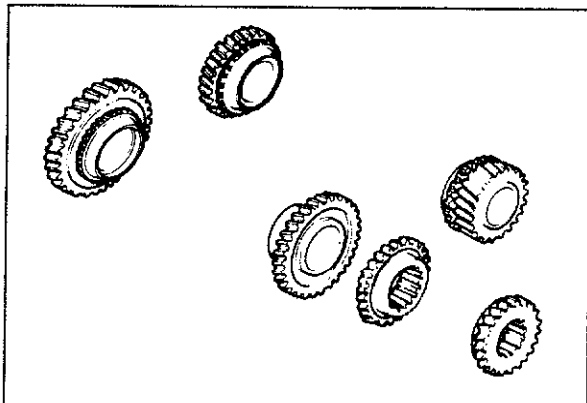

63U07A-064

## INSPECTION

Check the following parts, and replace if necessary.

### 1st, 2nd, 3rd, 4th, and 5th gears

1. Worn or damaged synchronizer cone.
2. Worn or damaged hub sleeve coupling.
3. Worn or damaged teeth.
4. Worn or damaged inner surface or end surface of gears.

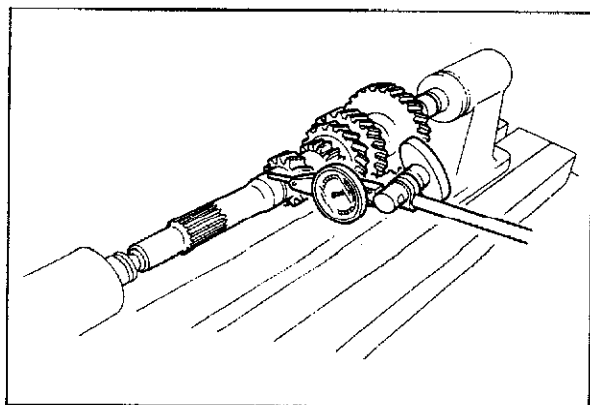

83U07A-066

### Primary Shaft Gear and Primary Gear (5 speed)

1. Worn teeth.
2. Primary shaft gear run-out.

**Standard run-out : 0.05 mm (0.002 in)**

#### Note

**If the shaft gear is replaced, adjust the bearing preload. (Refer to Page 7A—36)**



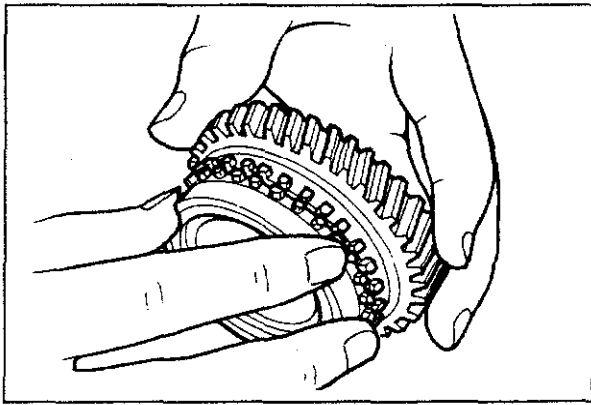

63U07A-066

**Synchronizer Ring**

1. Engagement with gear.
2. Worn or damaged teeth.
3. Worn or damaged tapered surface.

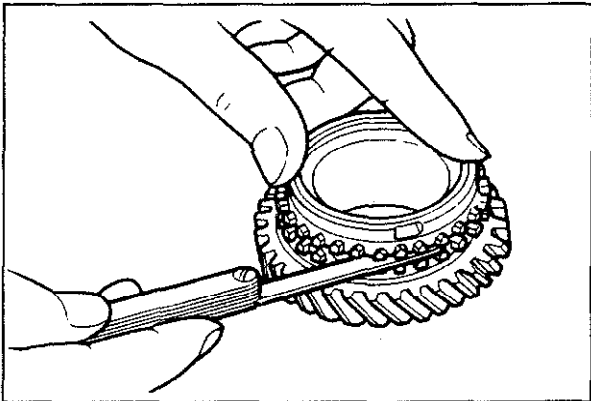

63U07A-067

4. Clearance from the side of gear.

**Standard: 1.5 mm (0.059 in)**

**Limit: 0.8 mm (0.031 in)**

**Caution**

- a) Press the synchronizer ring uniformly against the gear and measure around the circumference.
- b) If the measured value is less than the limit, replace the synchronizer ring or gear.

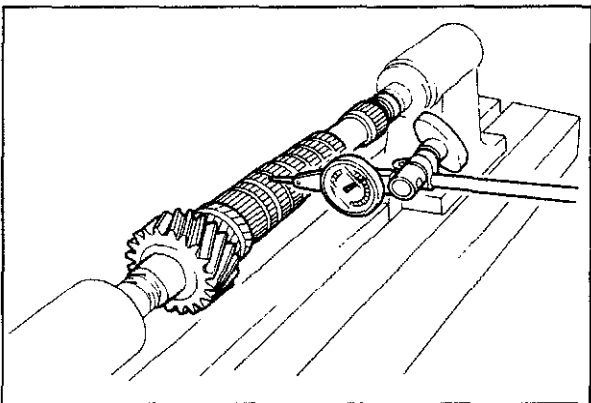

63U07A-068

**Secondary Shaft Gear**

1. Worn or damaged gear contact surface.
2. Worn or damaged splines.
3. Worn teeth.
4. Clogged oil passage.
5. Secondary shaft gear run-out.

**Standard run-out: 0.015 mm (0.0006 in)**

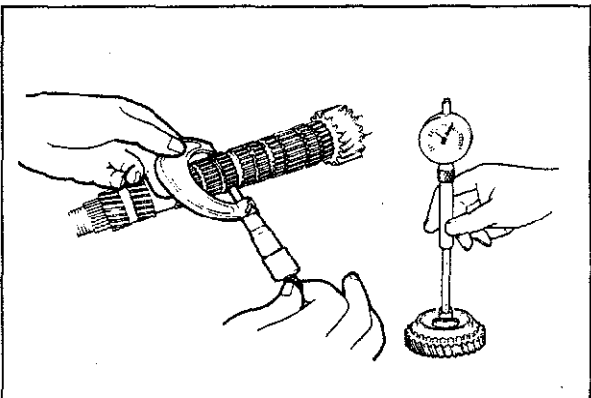

63U07A-069

6. Oil clearance between secondary gear shaft and gears.

**Standard: 0.03—0.08 mm (0.001—0.003 in)**

**Caution**

**If the shaft gear is replaced, adjust the bearing preload.**

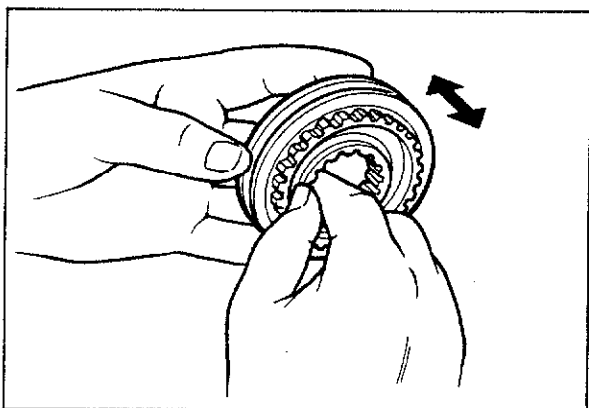

63U07A-070

### Clutch Hub

1. Worn or damaged splines.
2. Worn or damaged synchronizer key groove.
3. Worn end surface.
4. Operation of the hub sleeve when it is installed.

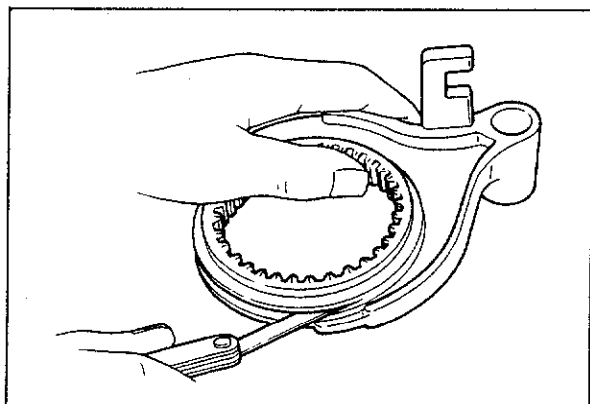

63U07A-071

### Clutch Hub Sleeve

1. Worn or damaged hub splines.
2. Worn or damaged sleeve fork groove.
3. Clearance between sleeve and shift fork.

**Standard: 0.2—0.458 mm (0.008—0.018 in)**  
**Limit: 0.5 mm (0.020 in)**

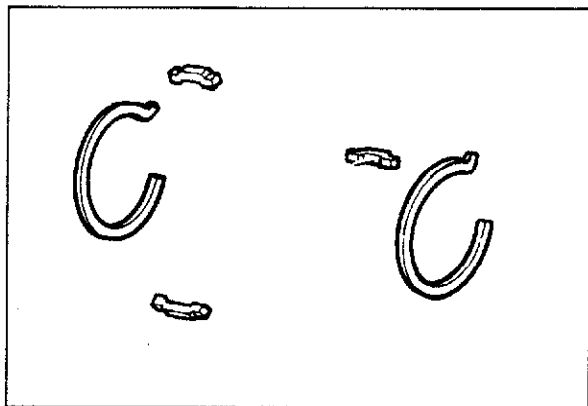

63U07A-072

### Synchronizer Key and Spring

1. Worn key.
2. Bent spring.

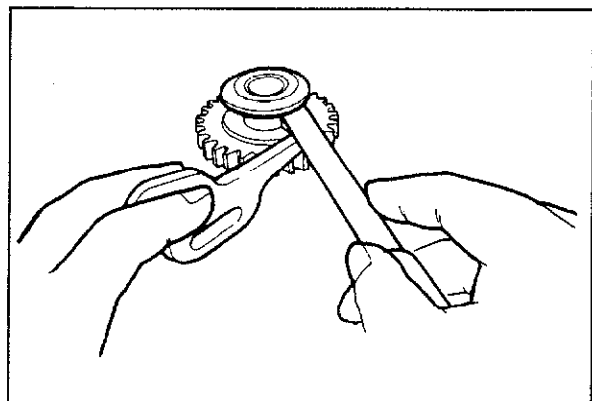

63U07A-073

### Reverse Idle Gear

1. Worn or damaged bushing.
2. Worn or damaged teeth.
3. Worn or damaged release lever coupling groove.
4. Clearance between sleeve and reverse lever.

**Standard: 0.095—0.318 mm (0.004—0.013 in)**  
**Limit: 0.5 mm (0.020 in)**

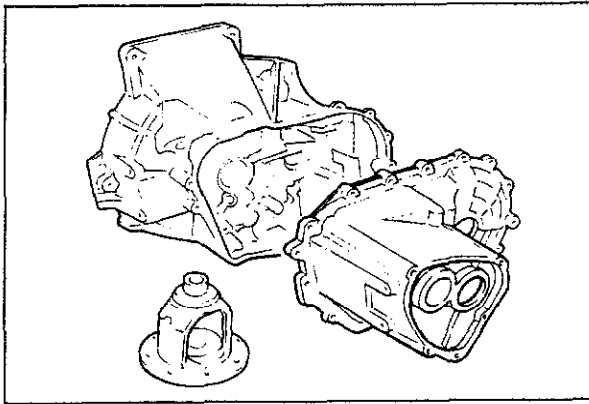

63U07A-074

### Clutch Housing, Transaxle Case, Rear Cover, and Differential Gear Case

Cracks or damage.

#### Caution

If the clutch housing, transaxle case, or differential gear case is replaced, adjust the bearing preload of the shaft gears and the preload of the differential side bearings.

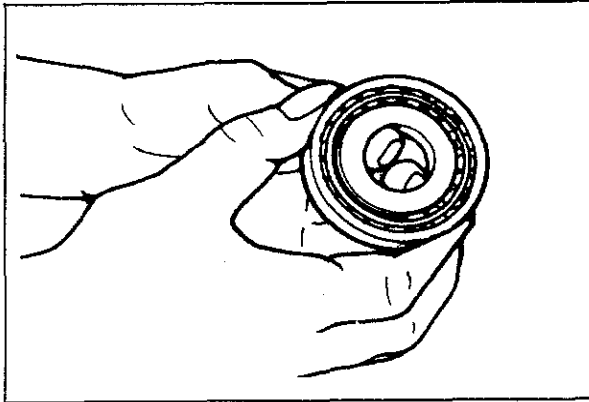

63U07A-075

### Bearing

1. Roughness or noise while turning
2. Worn or damaged outer race or rollers

#### Caution

- a) Replace the bearing, the outer race, and the inner race as a unit.
- b) If the bearing is replaced, adjust the preload.

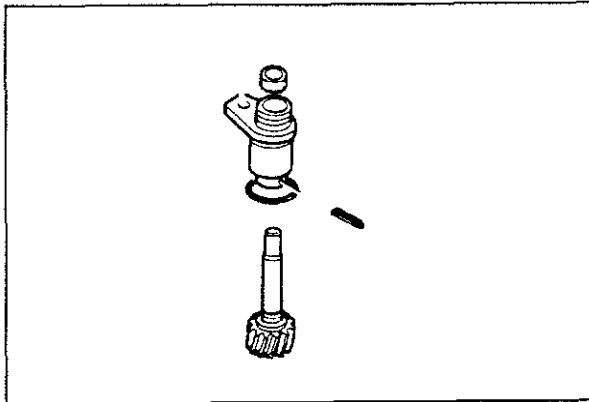

63U07A-076

### Speedometer Driven Gear Assembly

1. Worn or damaged teeth.
2. Worn or damaged O-ring.

### Ring Gear Speedometer Drive Gear

Worn or damaged teeth.

### Oil Seal

Damaged or worn lip.

## ASSEMBLY

### Note

- a) Wash all parts.
- b) Apply oil to all friction surfaces.
- c) Use new spring pins and retaining rings.

### DIFFERENTIAL

Assemble in the numbered order shown in the figure.

63U07A-077

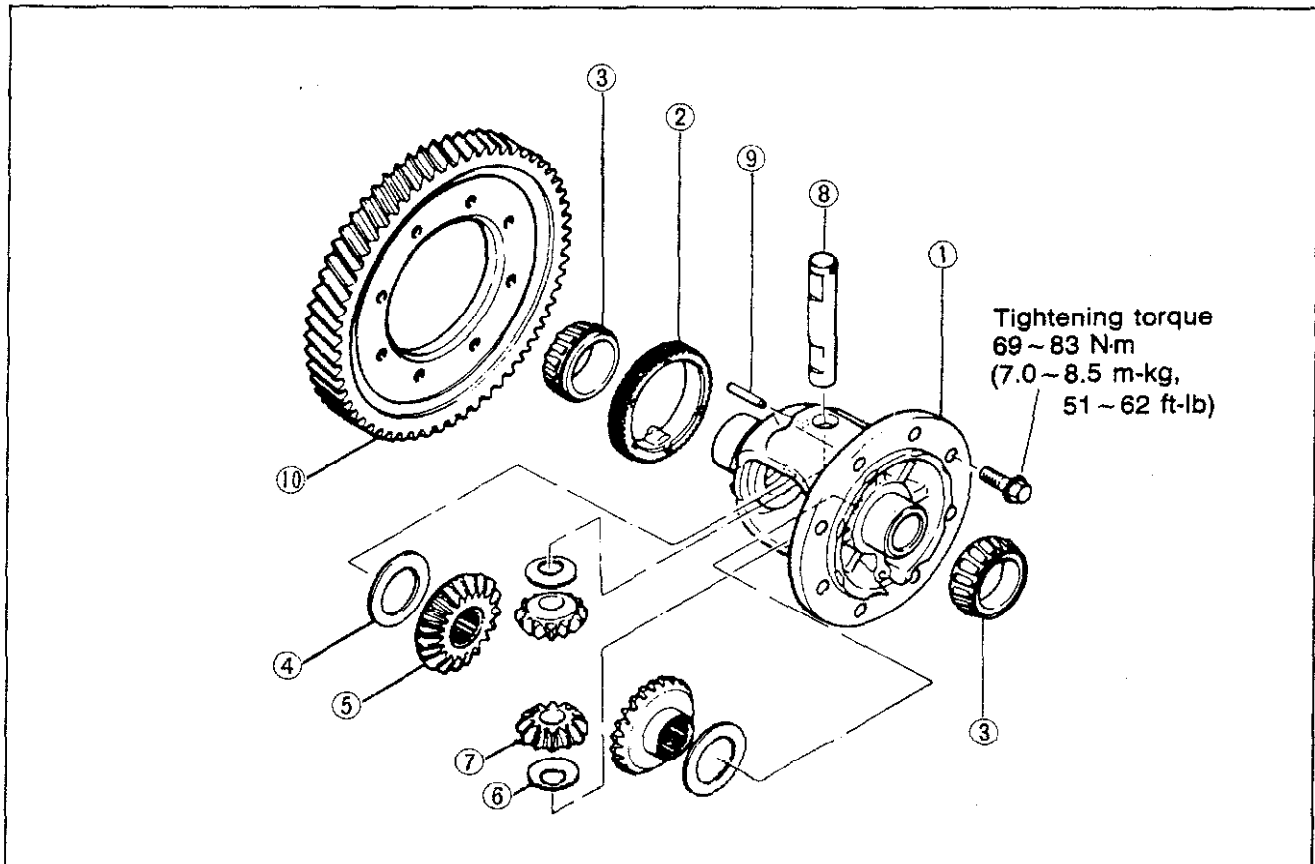

63U07A-078

- 1. Gear case
- 2. Speedometer drive gear
- 3. Side bearing inner race
- 4. Thrust washer
- 5. Side gear
- 6. Thrust washer
- 7. Pinion gear
- 8. Pinion shaft
- 9. Knock-pin
- 10. Ring gear

### Side Bearing Inner Race

Install the side bearing inner race by the **SST**, as shown in the figure.

### Note

Press to 19,620N (2,000 kg, 4,400 lb)

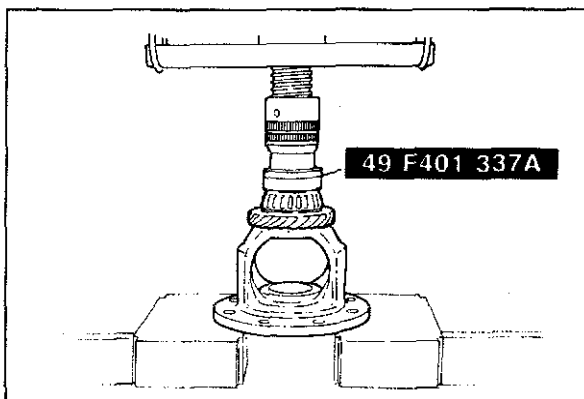

83U07A-067

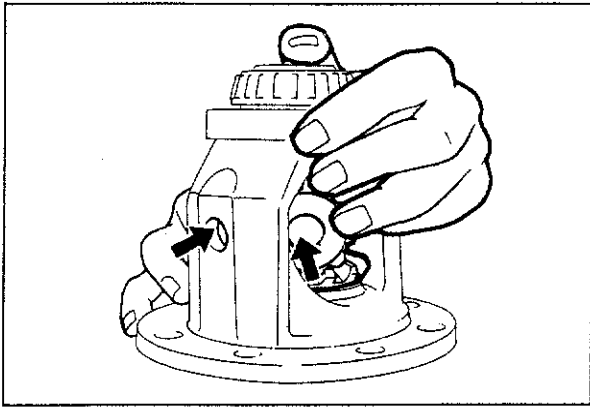

63U07A-080

### Side Gear and Pinion Gear

After installing thrust washers on the side gears, place the two side gears into the gear case at the same time, turn them back on the pinion gear and install them into the gear case.

#### Note

**The pinion gears and pinion shaft hole must be aligned.**

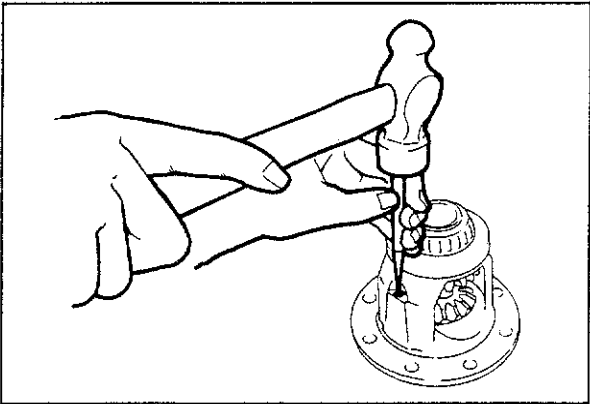

63U07A-081

### Knock-pin

After installing the knock pin, make a crimp so that the pin cannot come out of the gear case.

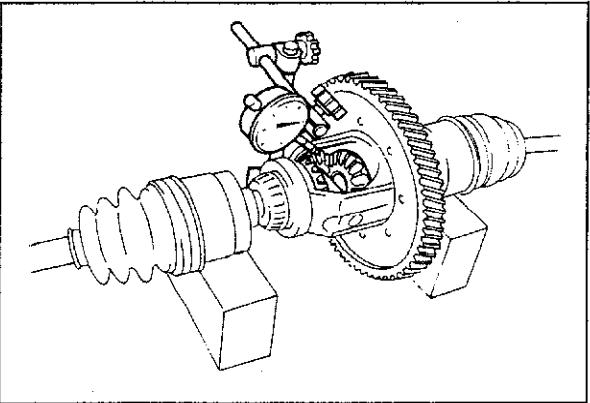

63U07A-082

### Backlash of Side Gear and Pinion Gear

Check and adjust by the following procedures:

1. Install the left and right driveshafts on the differential assembly.
2. Support the driveshafts on V-blocks, as shown in the figure.
3. Measure the backlash of both pinion gears.

**Standard backlash: 0—0.1 mm (0—0.004 in)**

Identification mark	Thickness
0	2.0 mm (0.079 in)
1	2.1 mm (0.083 in)
2	2.2 mm (0.087 in)

63U07A-083

4. If the backlash is more than the standard, adjust by selecting a thrust washer from the table to go between the case and side gears.

#### Note

**Use thrust washers with the same thickness on each side as much as possible.**

# 7A ASSEMBLY

## ASSEMBLY-STEP 1

Assemble in the numbered order shown in the figure.

### Note

1—5 are for 5 speed only. During assembly, check the thrust clearance of each gear.  
(Refer to Page 7A—34)

83U07A-068

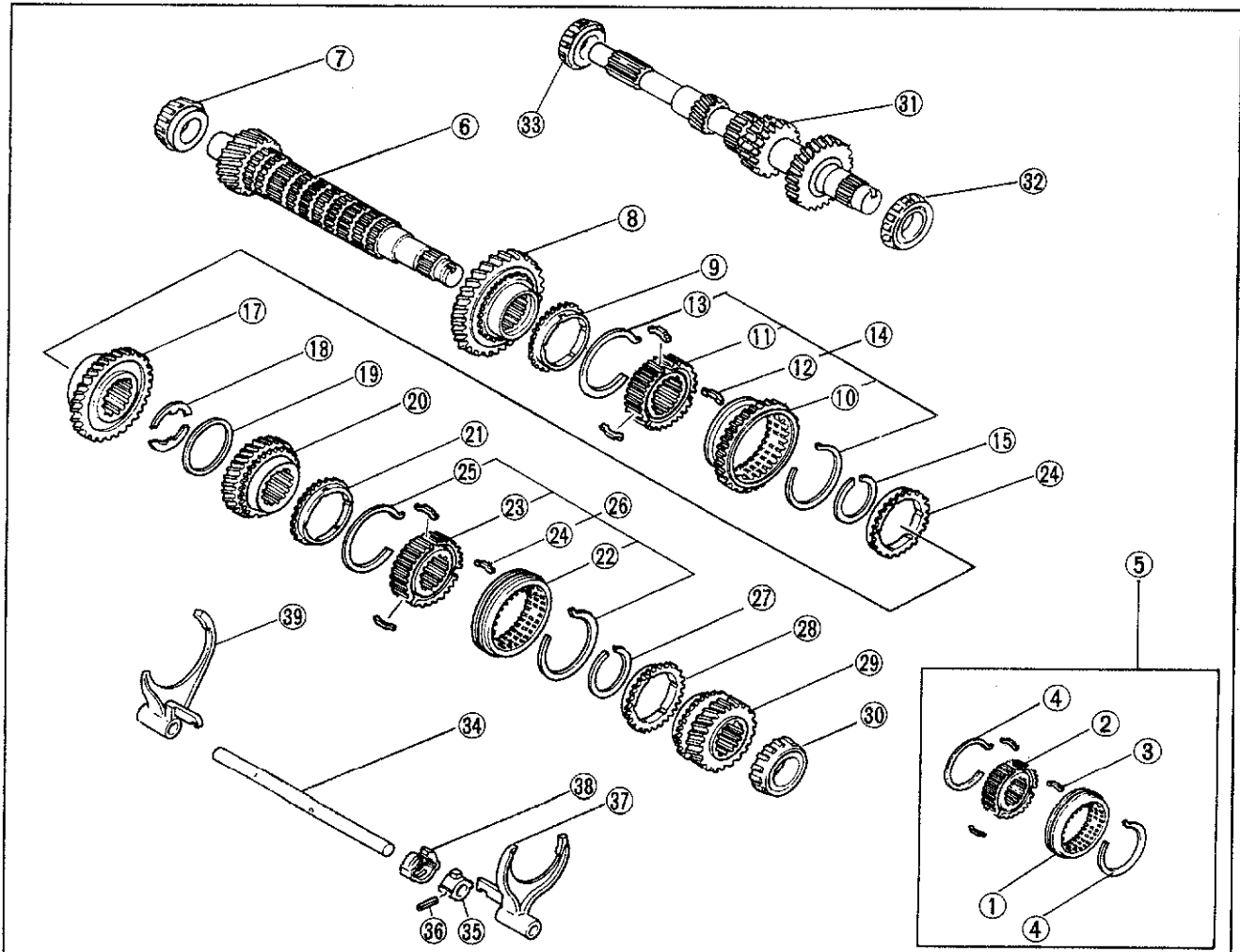

63U07A-065

- |                                      |   |                                  |
|--------------------------------------|---|----------------------------------|
| 1. Clutch hub sleeve                 | 14. Clutch hub assembly (1st - 2nd gears) | 27. Retaining ring               |
| 2. Clutch hub                        | 15. Retaining ring                        | 28. Synchronizer ring            |
| 3. Synchronizer key                  | 16. Synchronizer ring                     | 29. 4th gear                     |
| 4. Synchronizer spring               | 17. 2nd gear                              | 30. Bearing inner race           |
| 5. Clutch hub assembly (5th)         | 18. Thrust washer                         | 31. Primary shaft gear           |
| 6. Secondary shaft gear              | 19. Ring                                  | 32. Bearing inner race           |
| 7. Bearing inner race                | 20. 3rd gear                              | 33. Bearing inner race           |
| 8. 1st gear                          | 21. Synchronizer ring                     | 34. Control rod                  |
| 9. Synchronizer ring                 | 22. Clutch hub sleeve                     | 35. Control lever                |
| 10. Clutch hub sleeve (reverse gear) | 23. Clutch hub                            | 36. Spring pin                   |
| 11. Clutch hub                       | 24. Synchronizer key                      | 37. Shift fork (3rd - 4th gears) |
| 12. Synchronizer key                 | 25. Synchronizer spring                   | 38. Interlock sleeve             |
| 13. Synchronizer spring              | 26. Clutch hub assembly (3rd - 4th gears) | 39. Shift fork (1st - 2nd gears) |

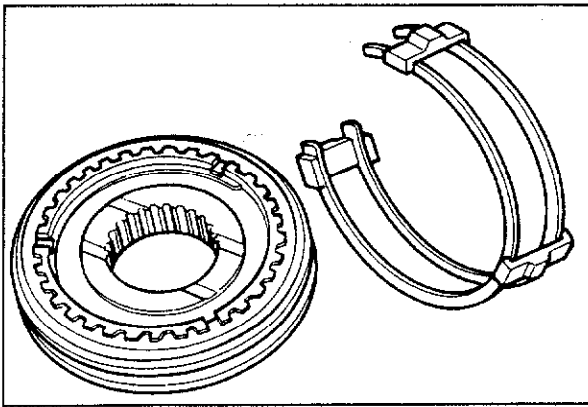

63U07A-086

### Clutch Hub Assembly

Install the synchronizer key-spring in the clutch hub by placing the hook in its groove. This holds the three synchronizer keys in place.

### Caution

The synchronizer keys for the 5th gear are to be installed in one direction. The wider side face of the synchronizer key must be install to reverse gear direction.

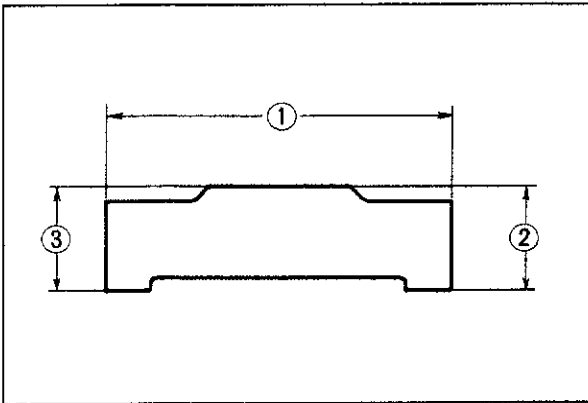

83U07A-095

	①	②	③
1st-2nd	19 (0.7480)	4.25 (0.1673)	4.25 (0.1673)
3rd-4th	17 (0.6693)	4.25 (0.1673)	4.25 (0.1673)
5th-Rev.	17 (0.6639)	4.25 (0.1673)	5.55 (0.2185)

mm (in)

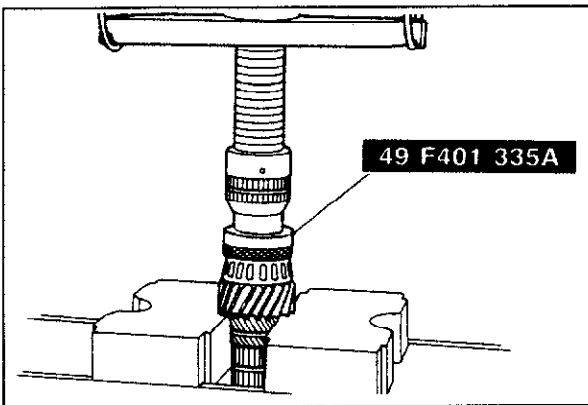

83U07A-096

### Bearing Inner Race (drive pinion end of secondary shaft gear)

Install the drive pinion end inner race on the secondary shaft gear with **SST** and a press, as shown in the figure.

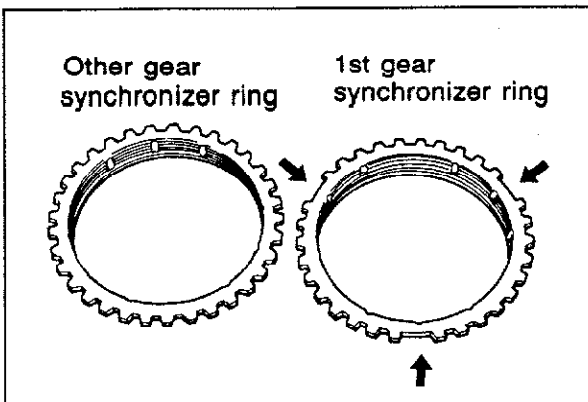

63U07A-088

### 1st Gear Synchronizer Ring

The 1st synchronizer ring is different from the other synchronizer rings

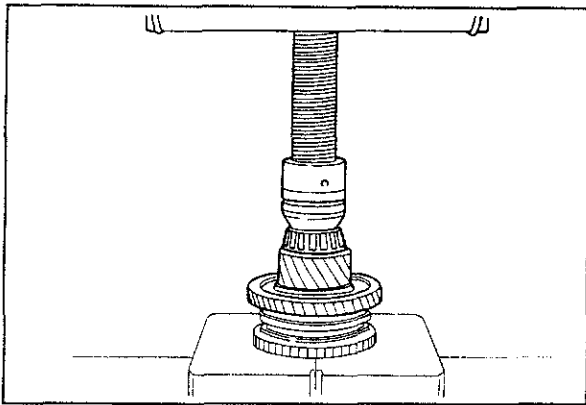

63U07A-090

### Retaining Ring

Install the retaining ring with snap ring pliers.

#### Note

**Make sure that the ring is seated properly in the groove.**

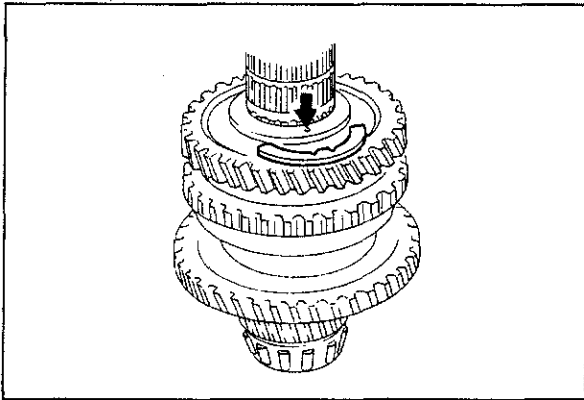

63U07A-091

### Thrust Washer

Install the thrust washer tangs into the holes in the groove.

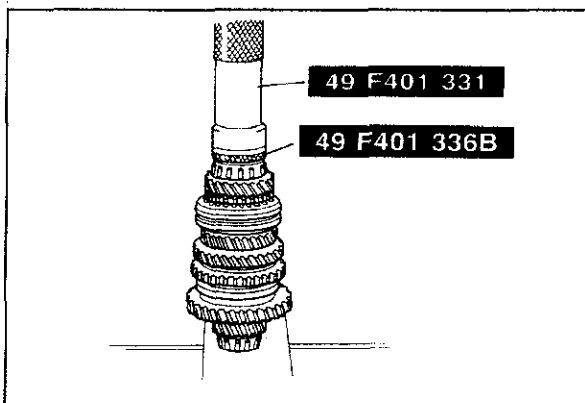

83U07A-069

### Bearing Inner Race (4th gear end of secondary shaft gear)

Press the inner race on the end of the secondary shaft with SST.

#### Note

**Press to 19,620N (2,000 kg, 4,400 lb)**

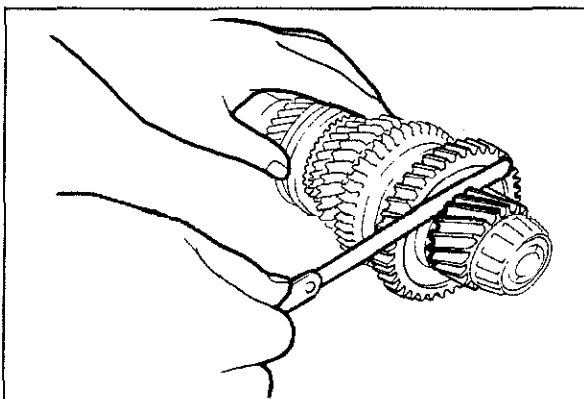

63U07A-093

### Thrust Clearance of 1st Gear

Measure the clearance between the 1st gear and the differential drive gear on the secondary shaft.

**Standard: 0.14—0.37 mm (0.006—0.015 in)**

**Limit: 0.42 mm (0.017 in)**



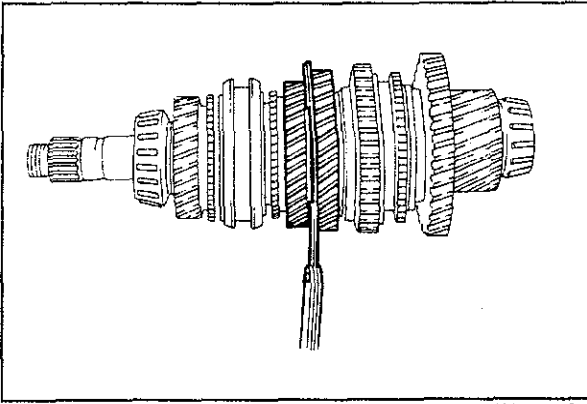

63U07A-094

### Thrust Clearance of 2nd Gear

Measure the clearance between the 2nd gear and the thrust washer.

**Standard: 0.245—0.580 mm (0.010—0.023 in)**  
**Limit: 0.63 mm (0.025 in)**

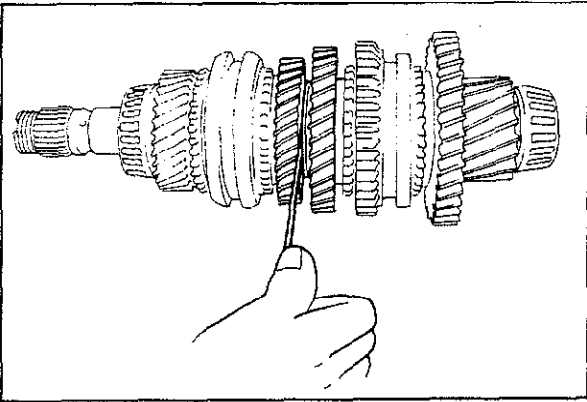

63U07A-095

### Thrust Clearance of 3rd Gear

Measure the clearance between the 3rd gear and the thrust washer.

**Standard: 0.095—0.38 mm (0.004—0.015 in)**  
**Limit: 0.43 mm (0.017 in)**

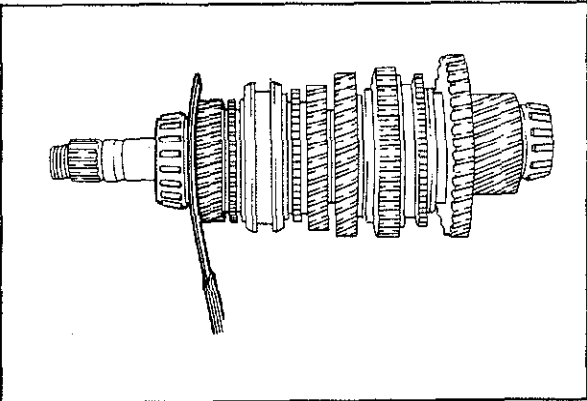

63U07A-096

### Thrust Clearance of 4th Gear

Measure the clearance between the 4th gear and the bearing inner race.

**Standard: 0.09—0.4 mm (0.004—0.016 in)**  
**Limit: 0.45 mm (0.018 in)**

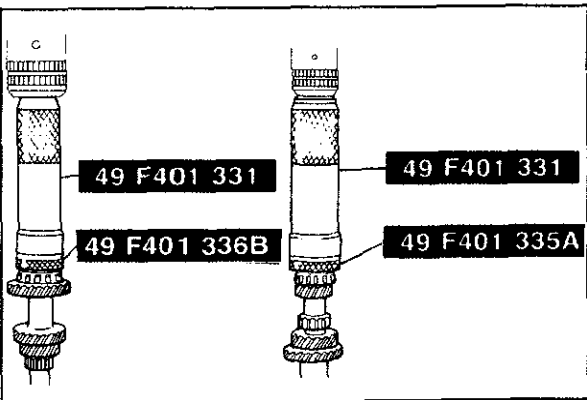

83U07A-070

### Bearing Inner Race (primary shaft)

Press the inner race on the end of the primary shaft (4th gear end) with **SST**.

Press the inner race on the opposite end of the primary shaft (1st gear end) with **SST**.

# 7A ASSEMBLY

## Bearing Preload

Adjust the bearing preload by selecting adjustment shim(s).

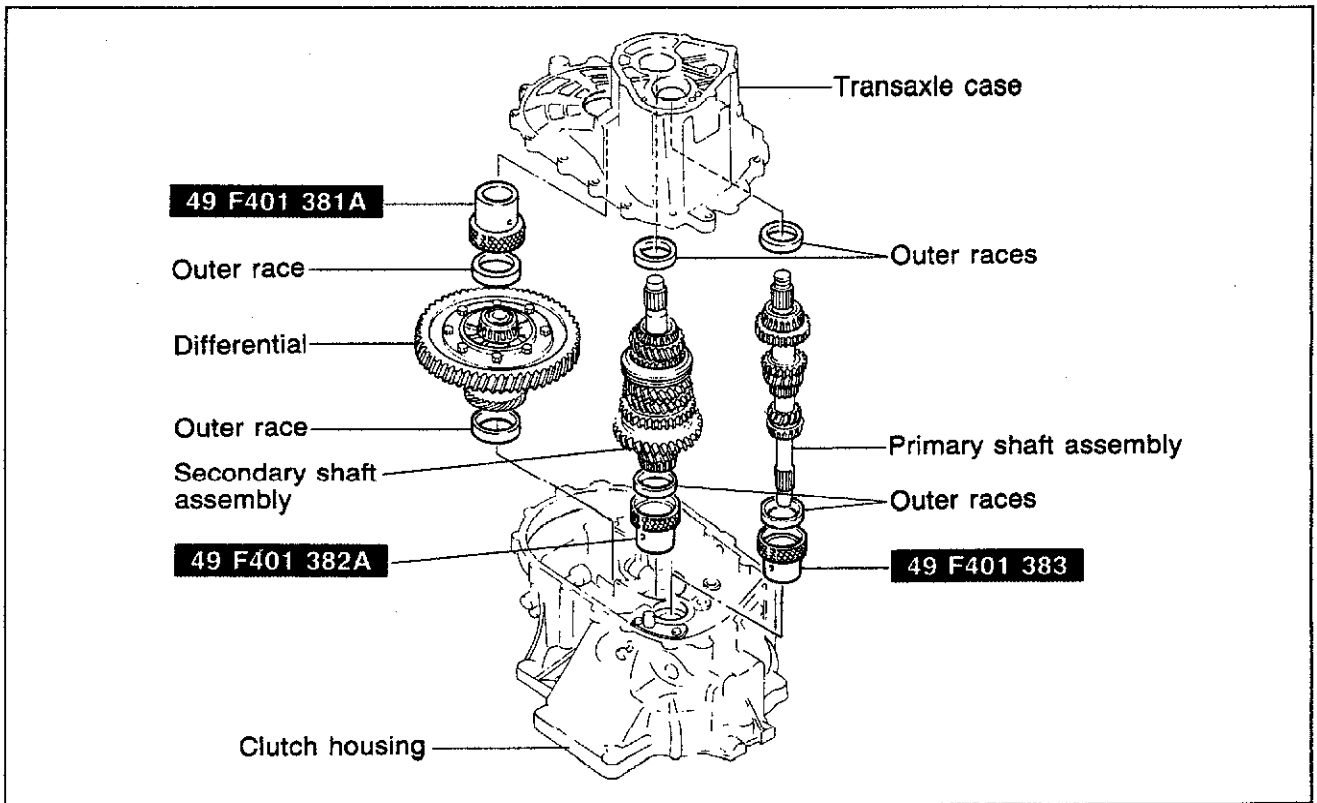
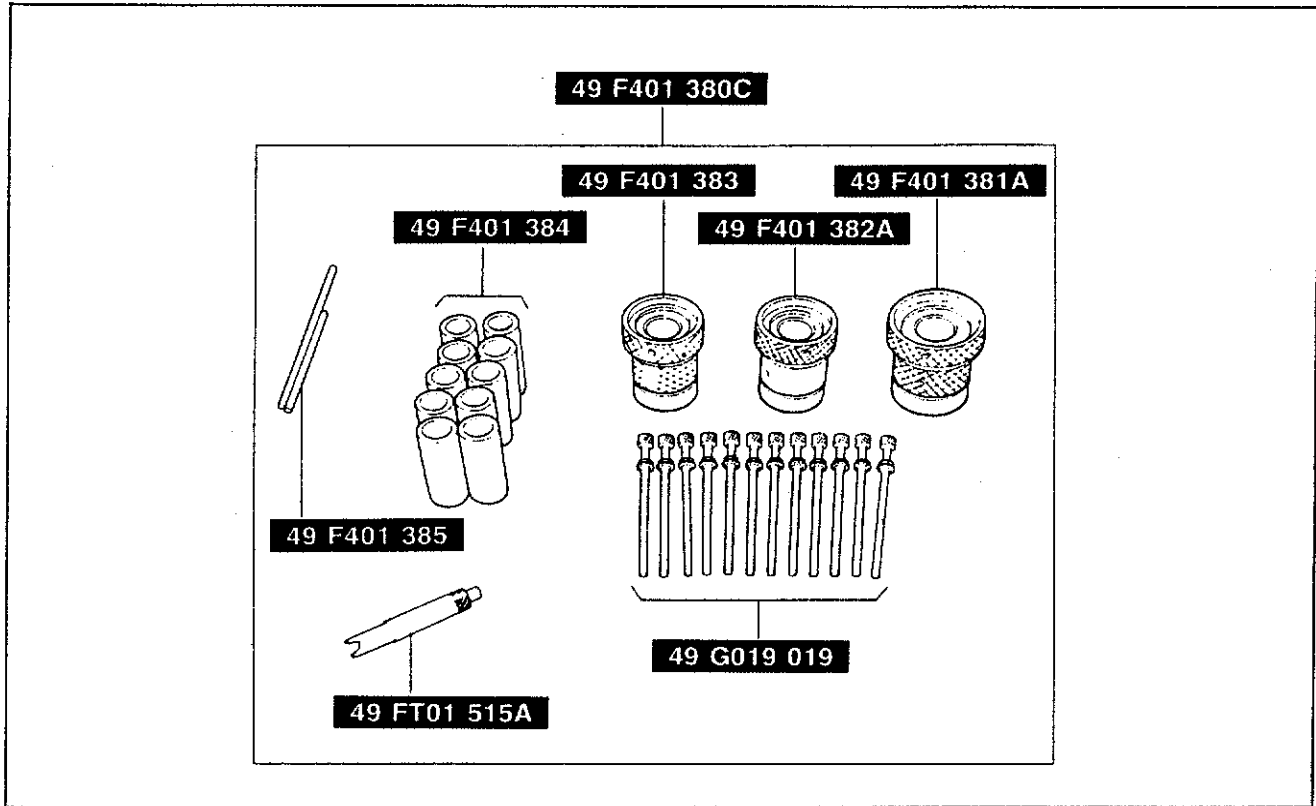

83U07A-071

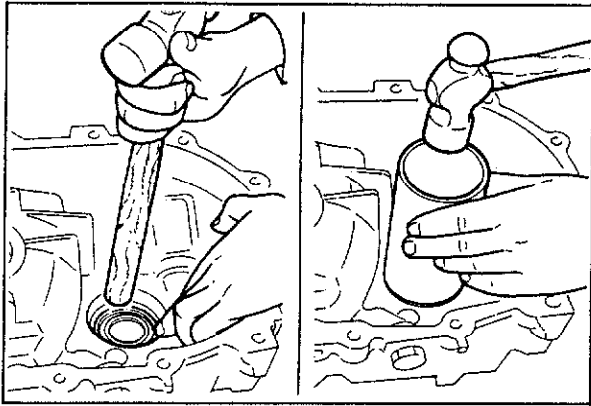

83U07A-072

1. Install the primary and secondary shaft bearing outer races into the transaxle case (shims removed).
2. After mounting the clutch housing onto the transaxle hanger, install the differential bearing outer race into the clutch housing.  
Next, position a piece of pipe against the outer race and tap in with a hammer until it contacts the clutch housing.

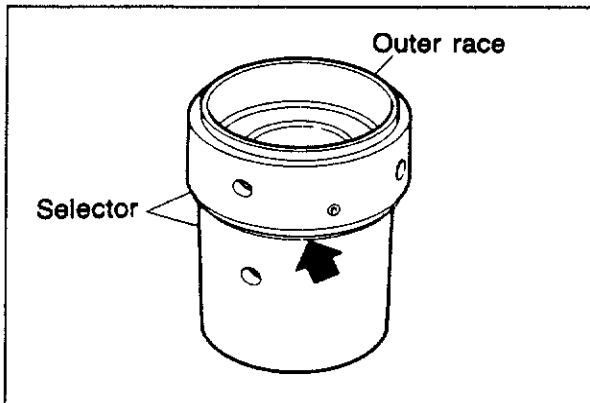

83U07A-097

3. As shown in the figure, put the outer races into the **SST** for primary (49 F401 383), for secondary (49 F401 382A).

**Caution**

Turn the **SST** to eliminate the gap indicated by the arrow in the figure.

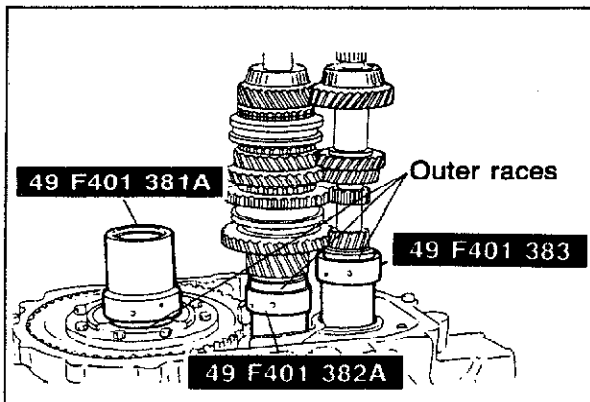

83U07A-073

4. Set the differential assembly into the clutch housing, and then mount the assembled **SST** and bearing outer race on the differential.  
Mount the assembled selectors and bearing outer races for the primary and secondary shaft into the clutch housing.  
Mount both shaft gear assemblies as shown in the figure.

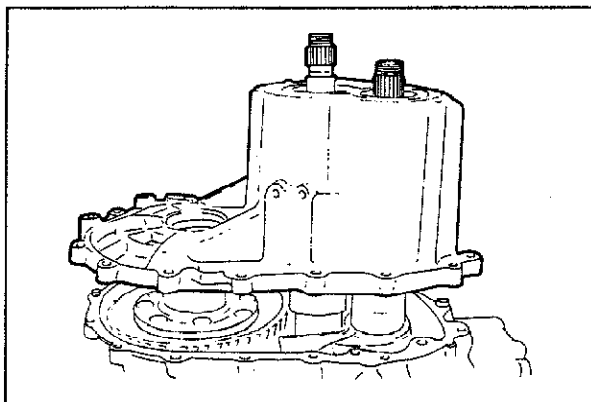

63U07A-103

5. Mount the transaxle case to the shafts and the differential selector, as shown in the figure.

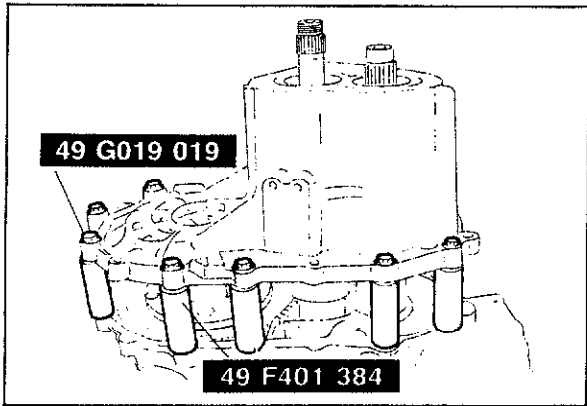

83U07A-074

6. Set the **SST** between the transaxle case and the clutch housing, and install the **SST**, and tighten to the specified torque.

**Tightening torque:**

**18—20 N·m (1.8—2.0 m·kg, 13—14 ft·lb)**

**Caution**

**Install the collars at the positions shown in the figure.**

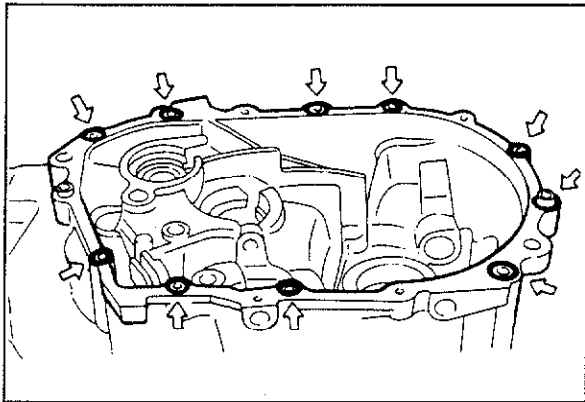

63U07A-105

7. To seat the bearings, mount the **SST** on parts (A) and (B) of the selector, and then turn the selector so the gap shown by the arrow in the figure is widened.

Move the bar by hand until the selector can no longer be turned, and then turn it in the reverse direction until the gap (arrow) is eliminated.

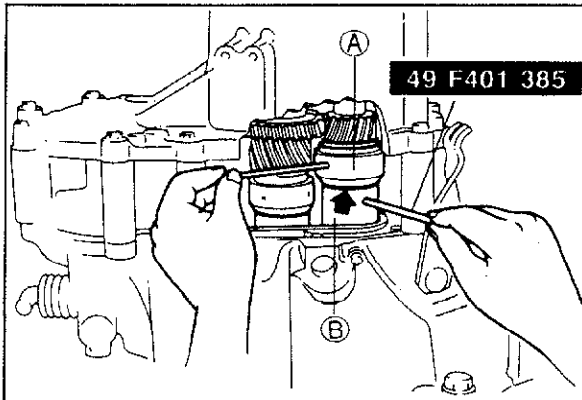

83U07A-075

8. Manually expand the selector for both shafts until the selector no longer turns.

**Caution**

**Make sure that each shaft gear turns smoothly.**

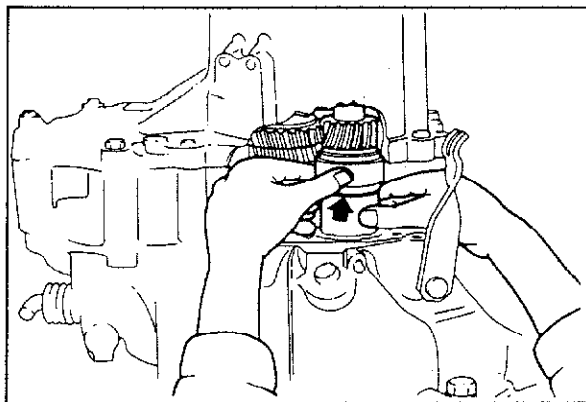

63U07A-107

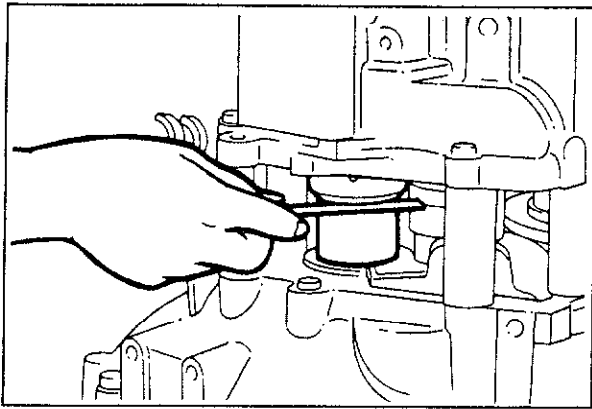

63U07A-108

9. Use a thickness gauge to measure the gap in the selector for both gears.

**Caution**

**Measure the gap around the entire circumference of the selector.**

Part No.	Thickness
99963 5120	0.20 mm (0.008 in)
99963 5125	0.25 mm (0.010 in)
99963 5130	0.30 mm (0.012 in)
99963 5135	0.35 mm (0.014 in)
99963 5140	0.40 mm (0.016 in)
99963 5145	0.45 mm (0.018 in)
99963 5150	0.50 mm (0.020 in)
99963 5155	0.55 mm (0.022 in)

63U07A-109

10. Select an appropriate adjustment shim.

(1) The shim to be used for the primary shaft gear should be selected by referring to the table and selecting the shim which is nearest (on the large side) to the value obtained, by subtracting the thickness of the diaphragm spring which goes between the shim and the race, from the measured value of the gap in the selector.

**Example: 0.94 mm (0.0370 in)**

**0.94 mm (0.0370 in) — 0.70 mm (0.0276 in)**  
**[Diaphragm spring]**

**= 0.24 mm (0.009 in)**

**So the nearest shim (on the large side) to 0.24 mm (0.009 in) is 0.25 mm (0.010 in).**

(2) The shim to be used for the secondary shaft gear should be selected by referring to the table and selecting the shim which is nearest (on the large side) to the measured value of the gap in the selector.

**Example: 0.39 mm (0.0154 in)**

**So the nearest shim (on the large side) to 0.39 mm (0.0154 in) is 0.40 mm (0.016 in).**

**Caution**

**The number of shims to be used must not be more than two.**

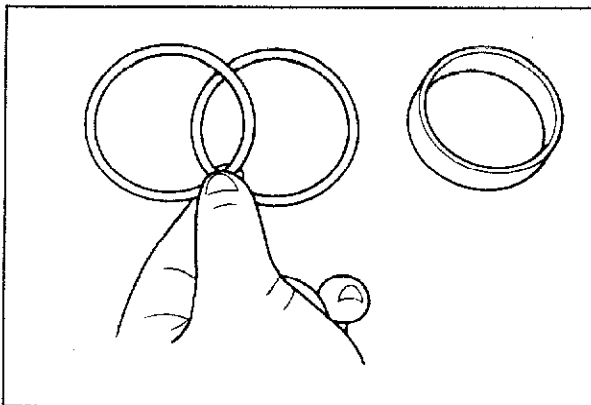

63U07A-110

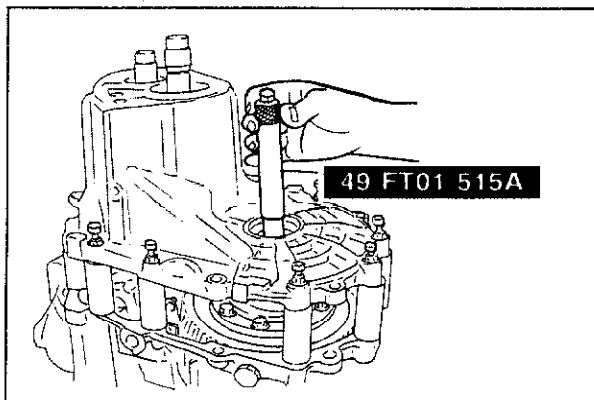

83U07A-076

11. Install the **SST**.

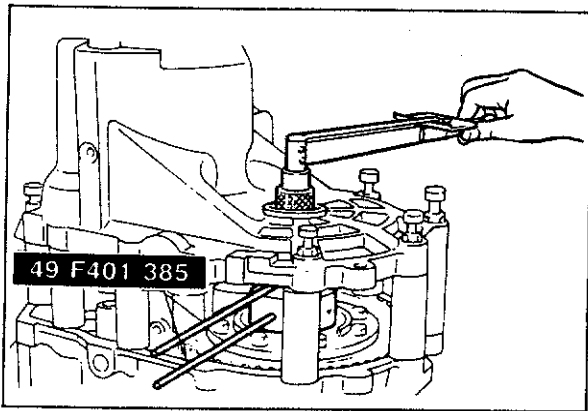

83U07A-077

12. Adjust the selector with the **SST** until the preload specification is obtained.

**Preload:**

**0.5—0.75 N·m (5—7.6 cm·kg, 4.3—6.6 in·lb)**

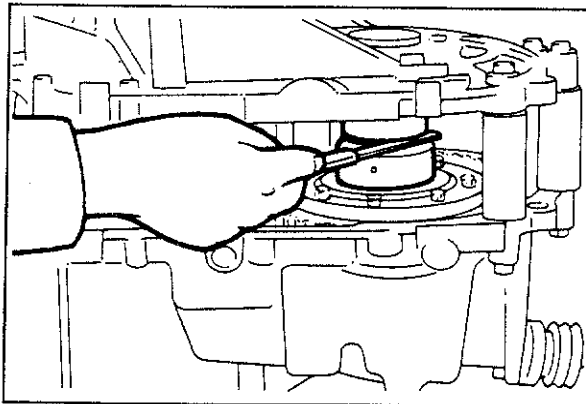

83U07A-113

13. Use a thickness gauge to measure the gap in the selector for the differential.

**Caution**

**Measure the gap around the entire circumference of the selector**

Part No.	Thickness
99963 5110	0.10 mm (0.004 in)
99963 5115	0.15 mm (0.006 in)
99963 5120	0.20 mm (0.008 in)
99963 5125	0.25 mm (0.010 in)
99963 5130	0.30 mm (0.012 in)
99963 5135	0.35 mm (0.014 in)
99963 5130	0.40 mm (0.016 in)
99963 5145	0.45 mm (0.018 in)
99963 5150	0.50 mm (0.020 in)
99963 5155	0.55 mm (0.022 in)
99963 5160	0.60 mm (0.024 in)
99963 5165	0.65 mm (0.026 in)
99963 5170	0.70 mm (0.028 in)
99963 5175	0.75 mm (0.030 in)
99963 5180	0.80 mm (0.032 in)
99963 5185	0.85 mm (0.034 in)
99963 5190	0.90 mm (0.036 in)

83U07A-114

14. Select an appropriate adjustment shim to be used for the differential. It should be selected by referring to the table and selecting the shim which is nearest (on the large side) to the largest measured value of the gap in the selector.

**Example: 0.54 mm (0.021 in)**

**So the nearest shim (on the large side) to 0.54 mm (0.021 in) is 0.55 mm (0.022 in).**

**Caution**

**The number of shims to be used must not be more than three.**

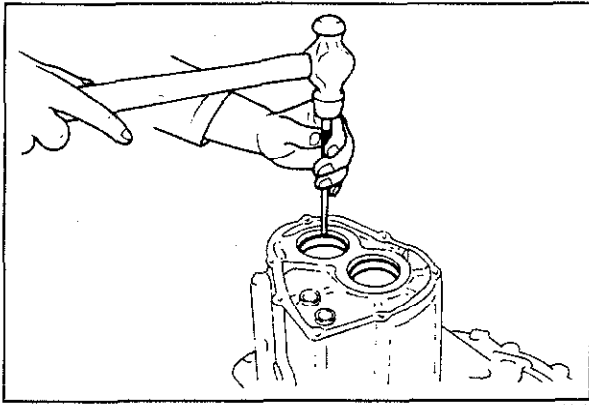

83U07A-078

15. Remove the **SST**, and then remove the transaxle case. Remove the shaft gears, selectors, and the differential.
16. Remove the bearing outer races for both shafts from the transaxle case.  
Leave the differential side bearing outer race in the clutch housing.

## ASSEMBLY-STEP 2

Assemble in the numbered order shown in the figure.

### Note

12, 26 and 27 are applicable to the 5 speed only.

63U07A-116

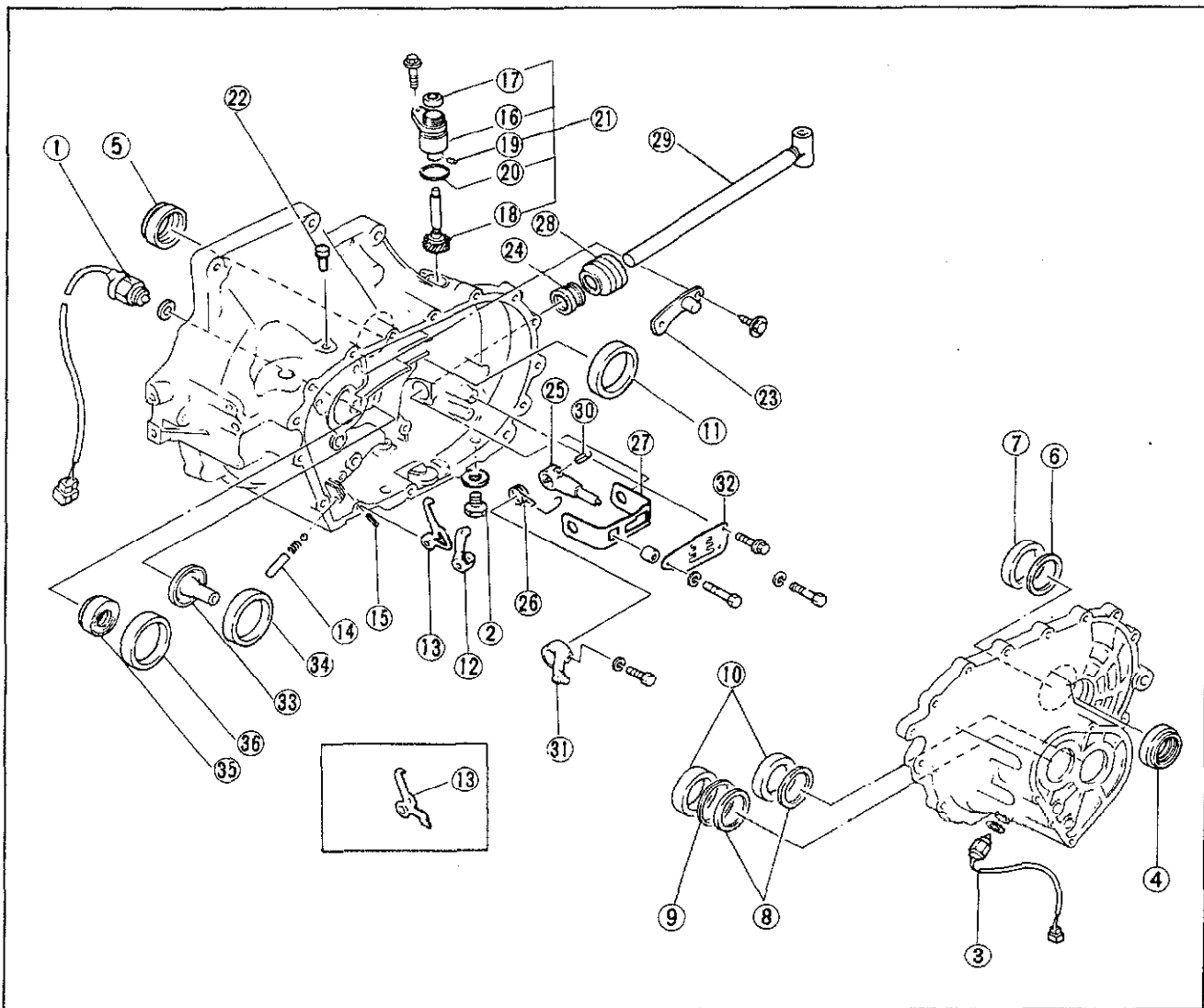

63U07A-117

- |                         |                                      |                        |
|-------------------------|--------------------------------------|------------------------|
| 1. Neutral switch       | 13. Reverse lever                    | 25. Selector           |
| 2. Drain plug           | 14. Reverse lever shaft              | 26. Spring             |
| 3. Back-up light switch | 15. Spring pin                       | 27. Reverse gate       |
| 4. Oil seal             | 16. Gear case                        | 28. Boot               |
| 5. Oil seal             | 17. Oil seal                         | 29. Change rod         |
| 6. Adjustment shim      | 18. Driven gear                      | 30. Spring pin         |
| 7. Bearing outer race   | 19. Spring pin                       | 31. Change arm         |
| 8. Adjustment shim      | 20. O-ring                           | 32. Guide plate        |
| 9. Diaphragm spring     | 21. Speedometer driven gear assembly | 33. Funnel             |
| 10. Bearing outer race  | 22. Breather                         | 34. Bearing outer race |
| 11. Bearing outer race  | 23. Breather cover                   | 35. Oil seal           |
| 12. Lever set spring    | 24. Oil seal                         | 36. Bearing outer race |



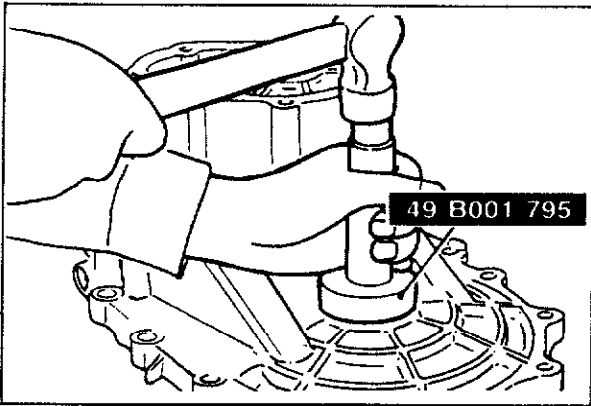

83U07A-079

### Oil Seal (differential)

Tap the differential oil seals into the transaxle case with the **SST**.

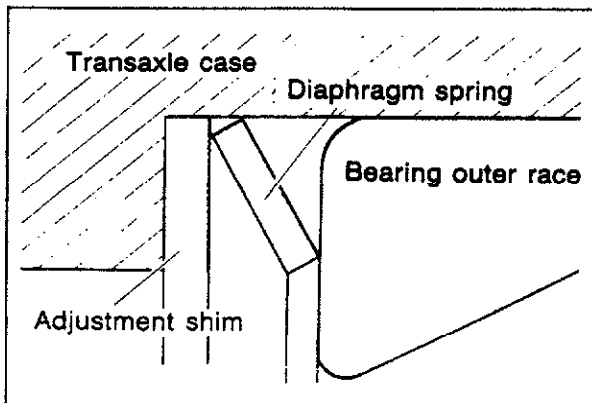

63U07A-119

### Bearing Outer Race

1. Install the selected adjustment shims and the diaphragm spring into the transaxle case.

#### Caution

**Install the diaphragm spring as shown in the figure.**

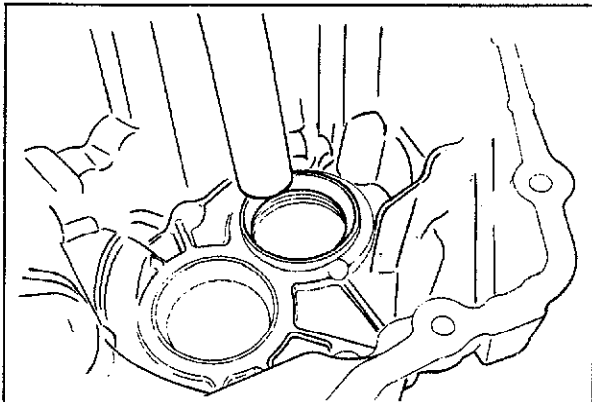

63U07A-120

2. Install the bearing outer races into the transaxle case and clutch housing.

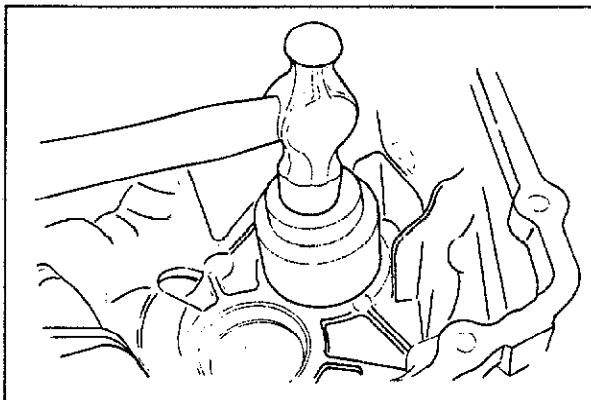

63U07A-121

3. Use a suitable pipe and a hammer to tap the outer races in until they are seated.

## ASSEMBLY-STEP 3

Assemble in the numbered order shown in the figure.

### Note

22—32 are applicable only to the 5 speed.

63U07A-122

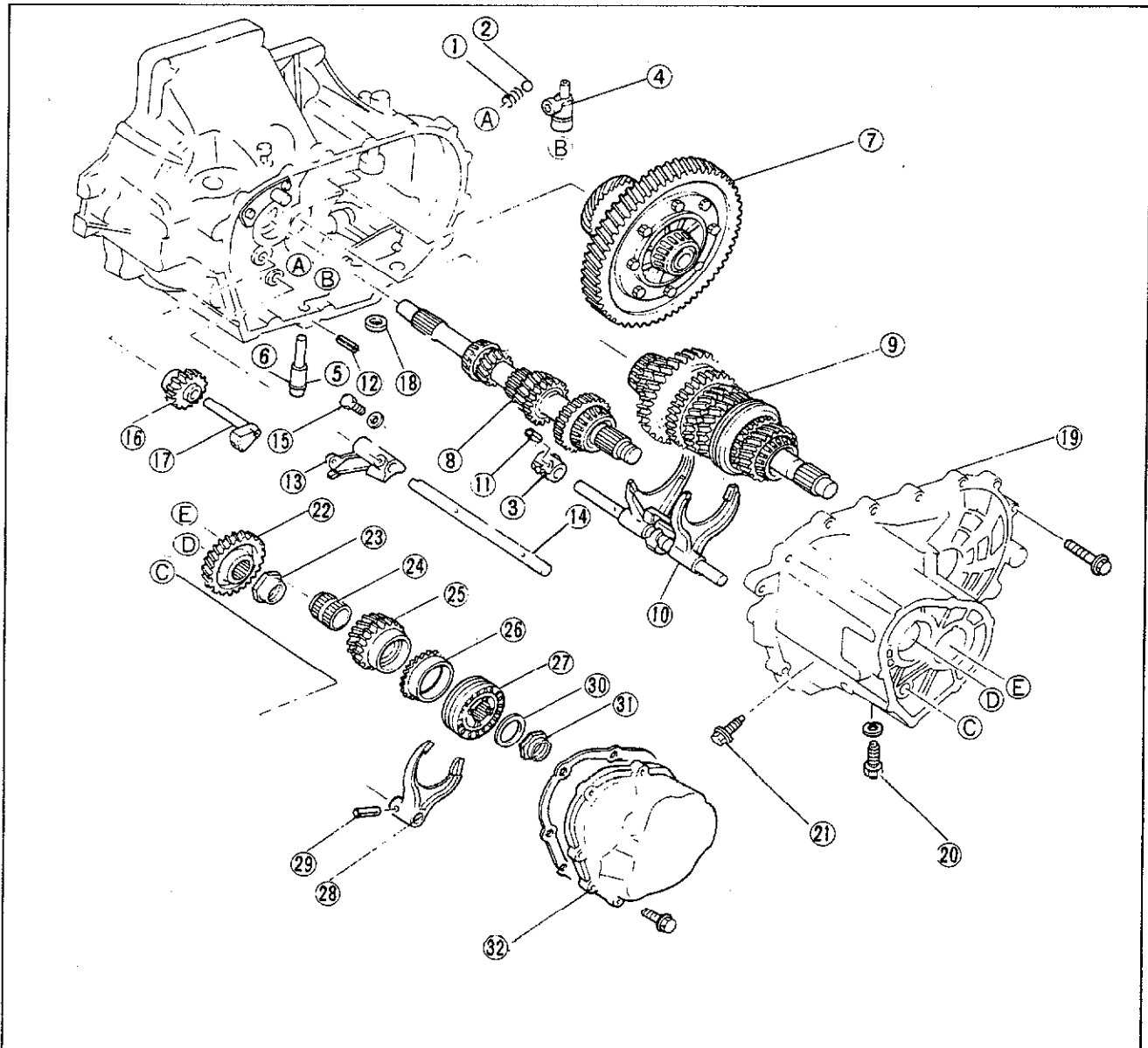

63U07A-123

- |                                  |                                 |                         |
|----------------------------------|---------------------------------|-------------------------|
| 1. Spring                        | 10. Shift fork assembly         | 22. Primary gear        |
| 2. Steel ball                    | 11. Spring pin                  | 23. Lock nut            |
| 3. Control end                   | 12. Spring pin                  | 24. Gear sleeve         |
| 4. Crank lever assembly          | 13. Gate                        | 25. 5th gear            |
| 5. O-ring                        | 14. Shift rod (5th and reverse) | 26. Synchronizer ring   |
| 6. Crank lever shaft             | 15. Lock bolt                   | 27. Clutch hub assembly |
| 7. Differential assembly         | 16. Reverse idle gear           | 28. Shift fork          |
| 8. Primary shaft gear assembly   | 17. Reverse idle shaft          | 29. Spring pin          |
| 9. Secondary shaft gear assembly | 18. Magnet                      | 30. Stopper plate       |
|                                  | 19. Transaxle case              | 31. Lock nut            |
|                                  | 20. Guide bolt                  | 32. Rear cover          |
|                                  | 21. Lock bolt                   |                         |

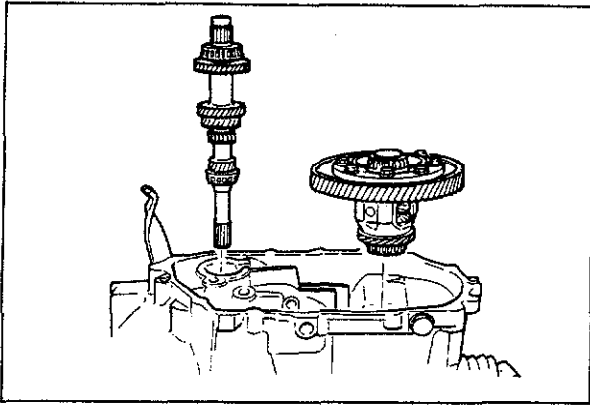

63U07A-124

### Bearing Preload

Check the primary shaft gear and the differential bearing preload.

#### Note

- a) Confirm that the correct adjustment shims were selected.
- b) If the bearing preload is not within the standard range, adjust again.

1. Install the primary shaft gear and the differential into the clutch housing.
2. Install the transaxle case, and tighten to the specified torque.

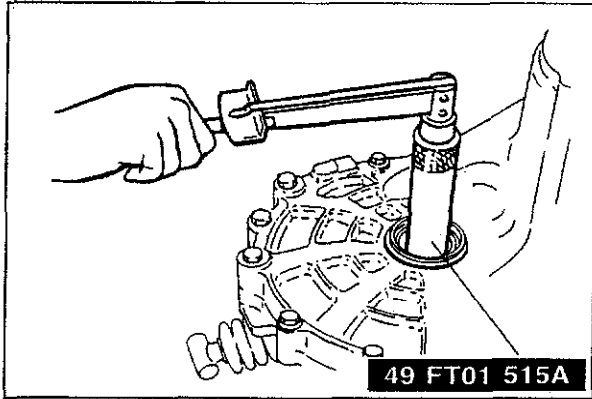

83U07A-080

### Tightening torque:

**18—26 N·m (1.8—2.6 m·kg, 13—19 ft·lb)**

3. Install the **SST**.
4. Measure the preload.

### Preload:

**0.03—0.75 N·m  
(0.3—7.6 cm·kg, 0.26—6.6 in·lb)**

5. Remove the adapter and the attachment.

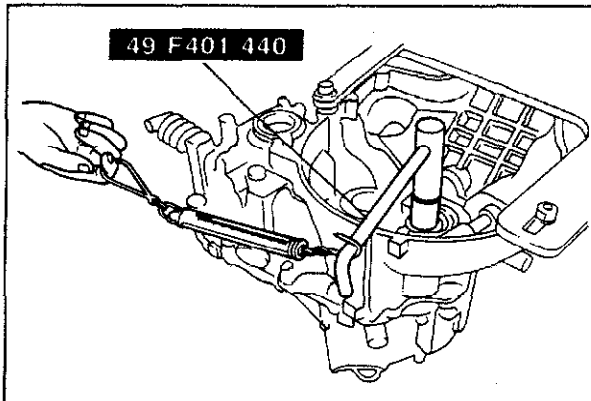

83U07A-081

6. With the transaxle facing in the direction shown in the figure, install the **SST** to the primary shaft gear. Hook the spring scale to the holder and measure the preload.

### Preload:

**0.10—0.34 N·m  
(1.0—3.5 cm·kg, 0.87—3.0 in·lb)**

### Spring scale reading:

**0.54—1.84 N (54—190 g, 0.12—0.41 lb)**

#### Note

**Extend the handle fully and hook the pull scale to the end of the handle.**

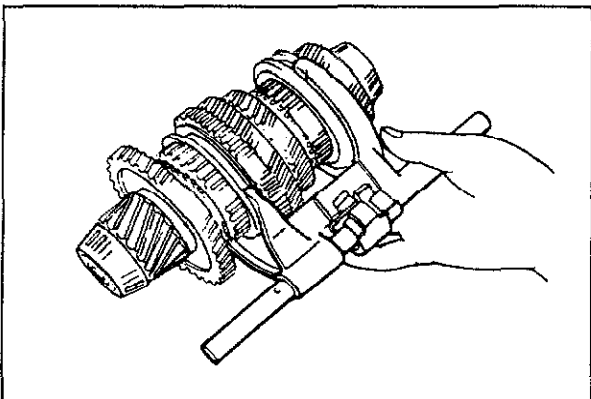

63U07A-127

### Shaft Gear and Shift Fork Assembly

Install the primary shaft gear, secondary shaft gear, and shift fork assembly according to the following procedures:

1. Install the shift fork assembly on the secondary shaft gear assembly.

#### Note

**Be careful of the rod direction.**

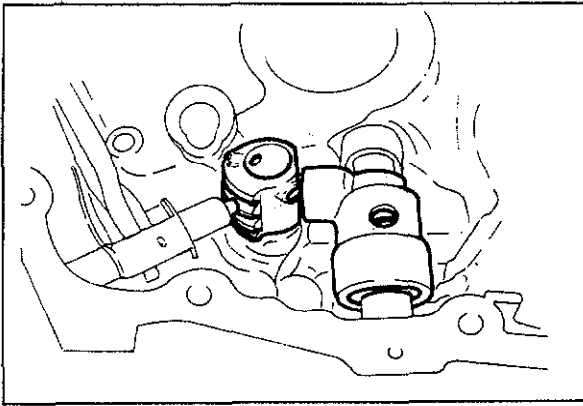

2. Assemble the control end, ball, spring, and crank lever to the clutch housing as shown in the figure.

**Caution**  
Be careful not to lose the ball and spring.

3. Install the differential assembly.

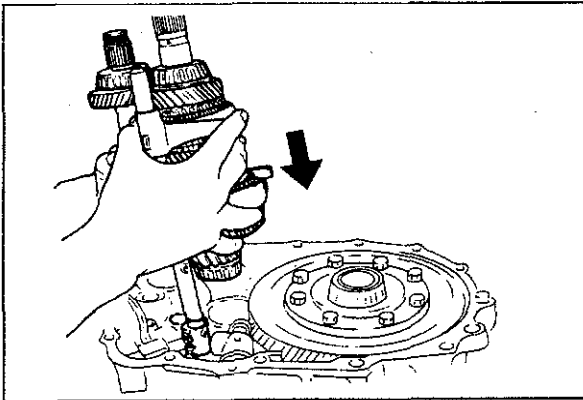

4. Unite the primary shaft gear, secondary shaft gear and shift fork assembly. Install the control rod into the control end as the unit is lowered into place.

**Note**  
Keep the assembly nearly vertical while installing it.

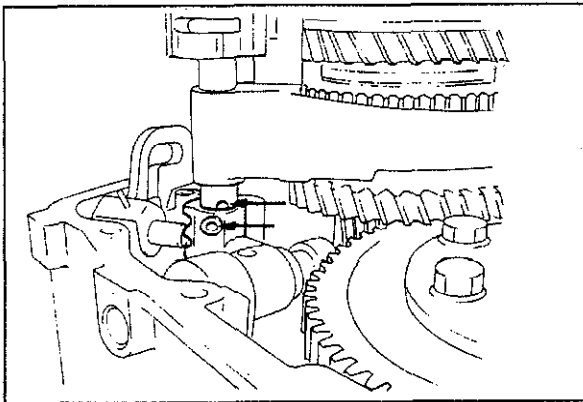

5. Align the holes in the control rod and the control end.

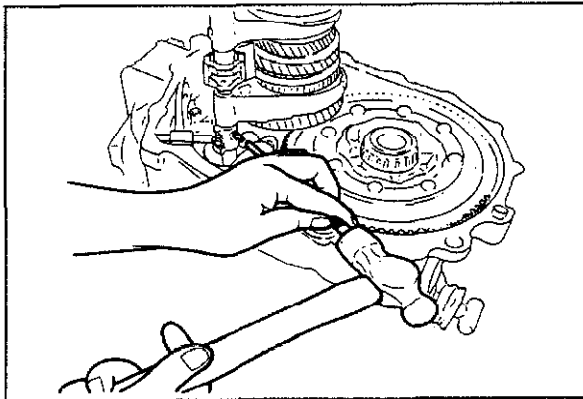

6. Tap the spring pin in with a pin punch and hammer.

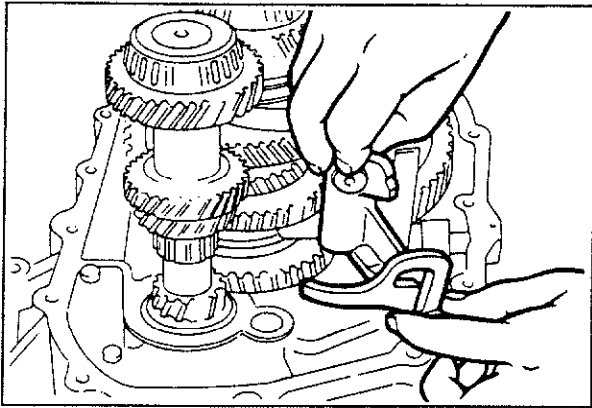

83U07A-098

### Gate

Raise the reverse lever and install the gate in its groove and guide pin.

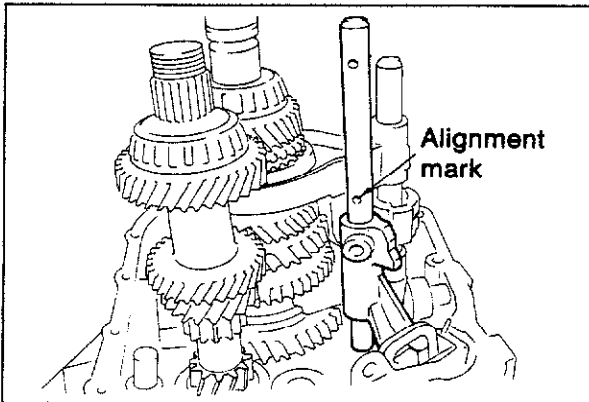

63U07A-133

### Shift Rod (5th and reverse)

When installing the shift rod (5th and reverse), make sure that the alignment mark on the rod is in the correct position.

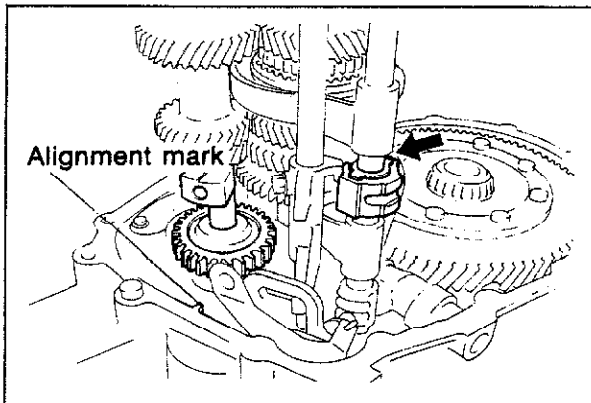

63U07A-134

### Interlock Sleeve and Reverse Idle Shaft

Before installing the transaxle case, make sure the control lever (arrow) is kept flush with the surface of the end of the interlock sleeve. Point the threaded hole of the reverse idle shaft toward the alignment mark of the clutch housing.

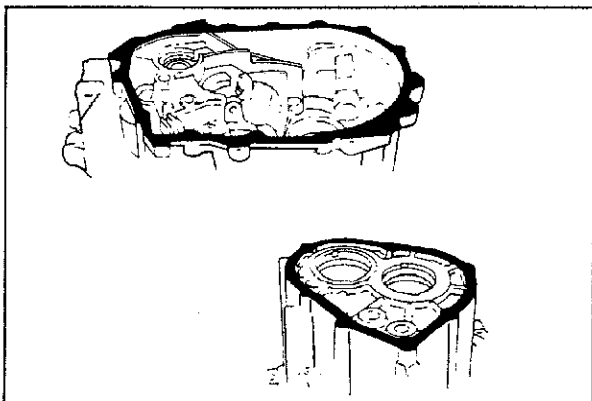

63U07A-135

### Sealant

Coat sealant sparingly onto the matching surfaces of the case and housing, and the case and rear cover.

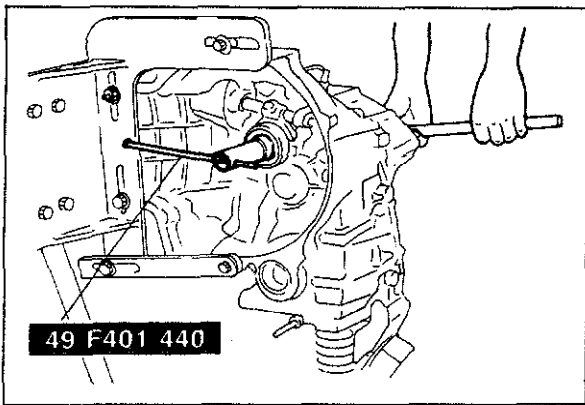

83U07A-082

### Lock Nut (primary gear)

Lock the shaft with the **SST** before tightening the locknut. Use a new locknut and tighten it to the specified torque. Stake the locknut to the groove in the primary shaft.

#### Tightening torque:

**128—206 N·m (13—21 m·kg, 94—152 ft·lb)**

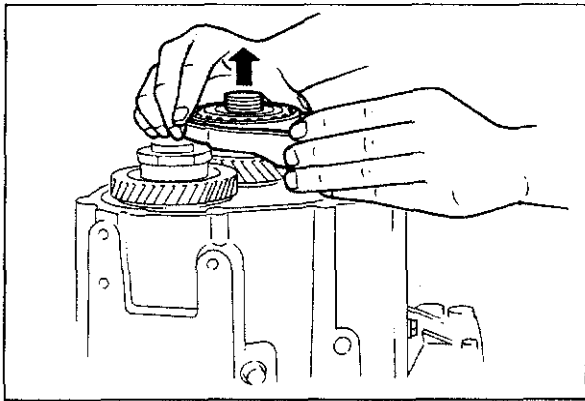

83U07A-136

### Shift Fork (5th gear)

Install the shift fork together with the clutch hub assembly.

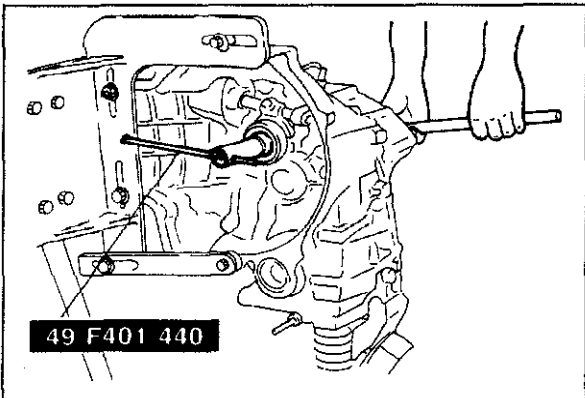

83U07A-083

### Lock Nut (5th clutch hub)

Put the transaxle in 1st or 2nd gear and lock the primary shaft with the **SST** and tighten the locknut on the secondary shaft to the specified torque. Stake the locknut to the groove in the secondary shaft.

#### Tightening torque:

**127—206 N·m (13—21 m·kg, 94—152 ft·lb)**

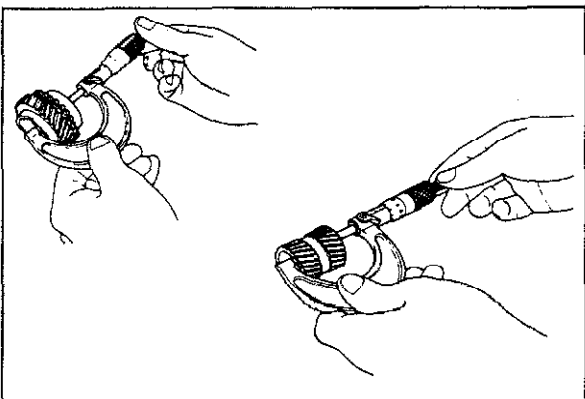

83U07A-138

### 5th Gear End Play

Measure the width of both the gear sleeve and the 5th gear.

The 5th gear end play equals the difference between the gear sleeve and the 5th gear.

**Standard: 0.15—0.262 mm (0.006—0.010 in)**  
**Limit: 0.31 mm (0.012 in)**

## G-type DISASSEMBLY

### DISASSEMBLY—STEP 1

Disassemble in the sequence shown in the figure.

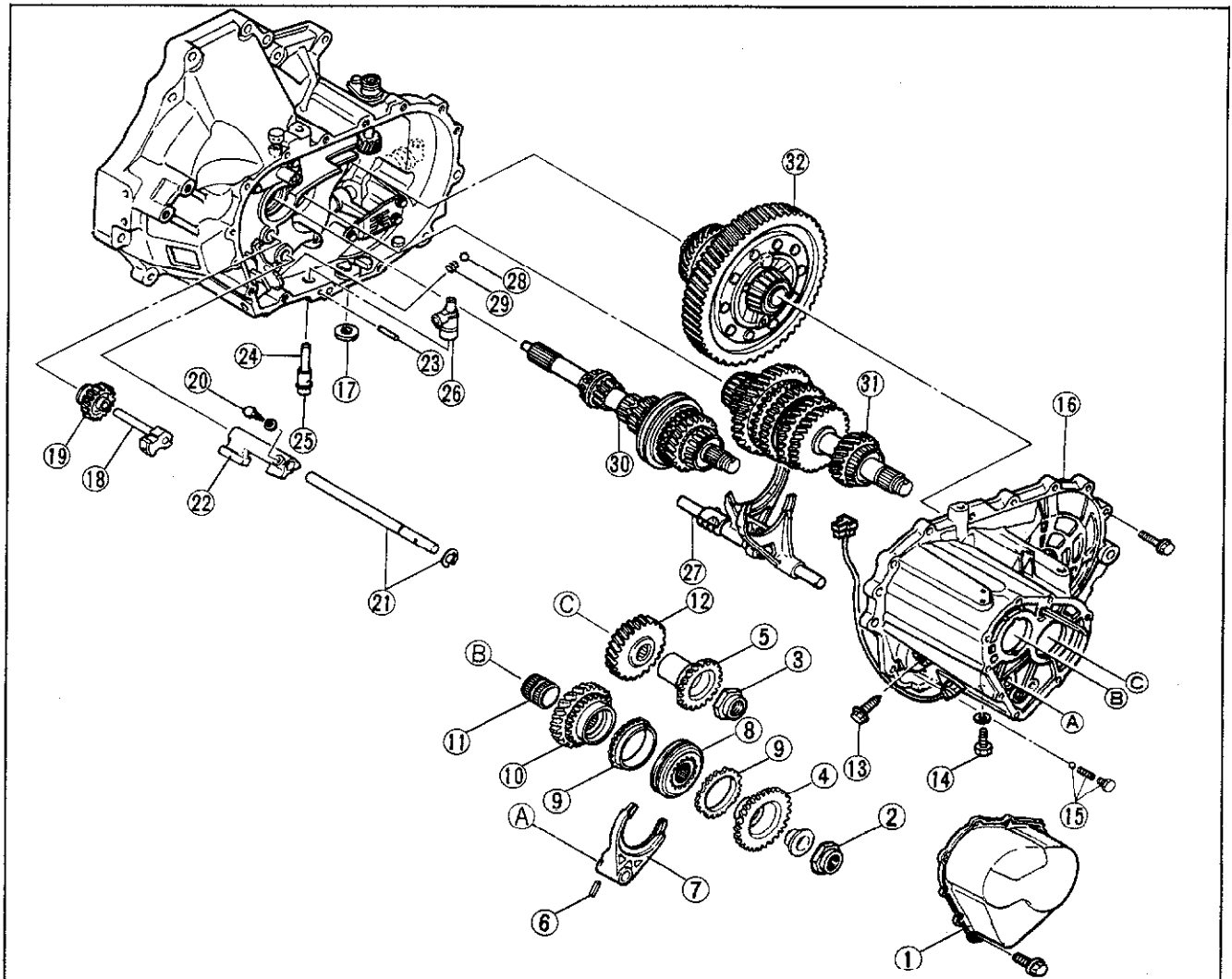

83U07A-010

- |  |  |   |
|--|--|---|
| 1. Rear cover                          | 13. Lock bolt                            | 25. O-ring                              |
| 2. Lock nut                            | 14. Guide bolt                           | 26. Crank lever assembly                |
| 3. Lock nut                            | 15. Lock bolt, and ball and spring       | 27. Shift fork and shift rod assembly   |
| 4. Primary reverse synchronizer gear   | 16. Transaxle case assembly              | 28. Steel ball                          |
| 5. Secondary reverse synchronizer gear | 17. Magnet                               | 29. Spring                              |
| 6. Spring pin                          | 18. Reverse idle shaft                   | 30. Primary shaft gear assembly         |
| 7. Shift fork                          | 19. Reverse idle gear                    | 31. Secondary shaft gear assembly       |
| 8. Clutch hub assembly                 | 20. Lock bolt                            | 32. Ring gear and differential assembly |
| 9. Synchronizer ring                   | 21. Shift rod (5th and reverse) and clip |   |
| 10. 5th gear                           | 22. Gate                                 |   |
| 11. Gear sleeve                        | 23. Pin                                  |   |
| 12. Secondary 5th gear                 | 24. Crank lever shaft                    |   |

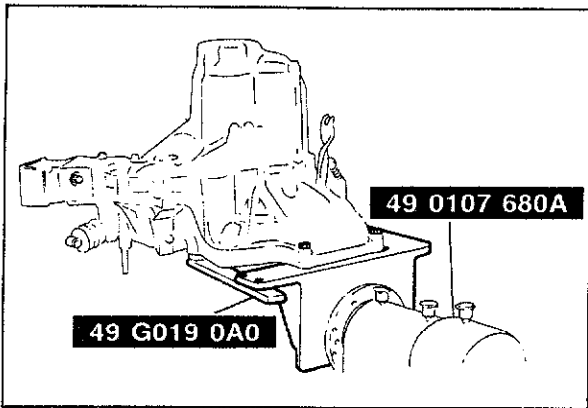

86U07A-084

## Transaxle

Position the **SST**, and mount the transaxle on the hanger.

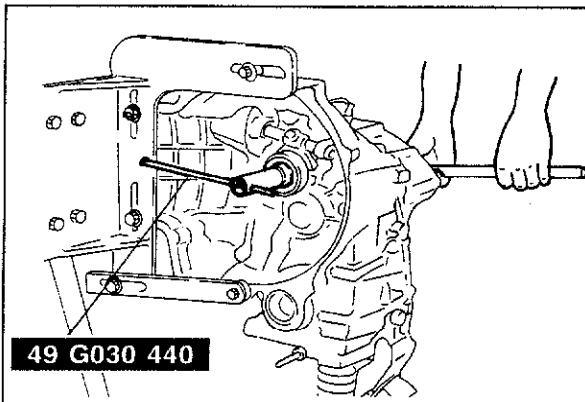

86U07A-085

## Lock Nut

Lock the primary shaft using the **SST**, and remove the lock nut.

### Note

- a) Turn the transaxle on its side.
- b) Shift to 1st or 2nd gear.

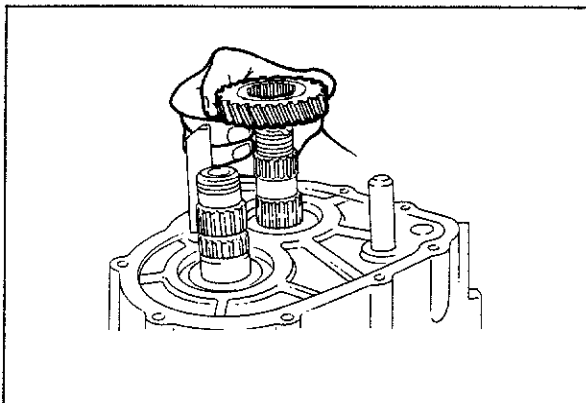

73G07A-026

## Secondary 5th Gear

Remove the secondary 5th gear.

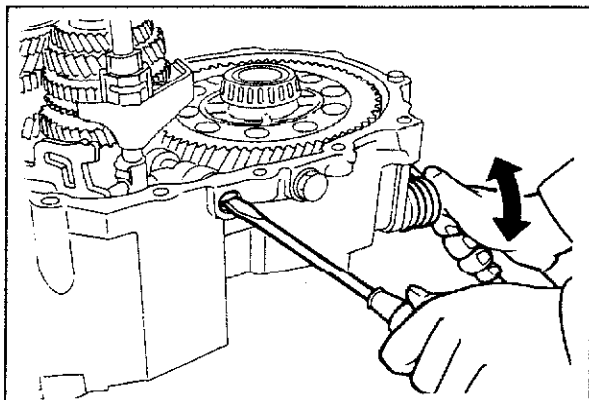

76U07A-042

## Crankshaft Lever Shaft

The crankshaft lever shaft can be removed by moving the change rod in the direction shown in the figure while turning the shaft with a flat-tipped screwdriver.



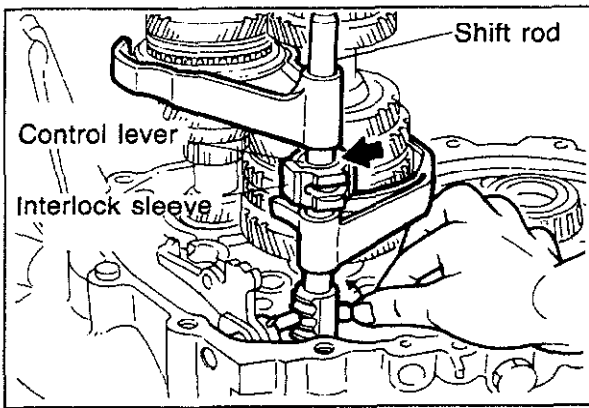

76U07A-226

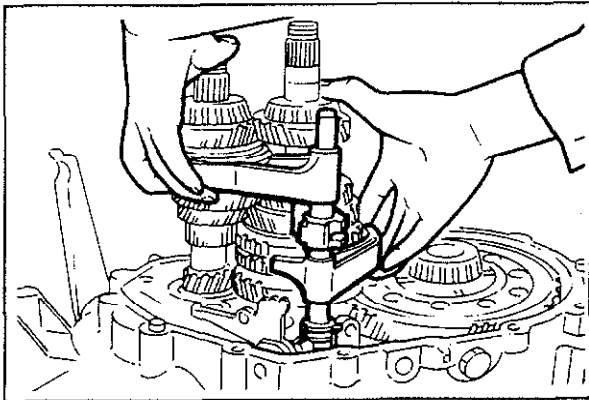

76U07A-044

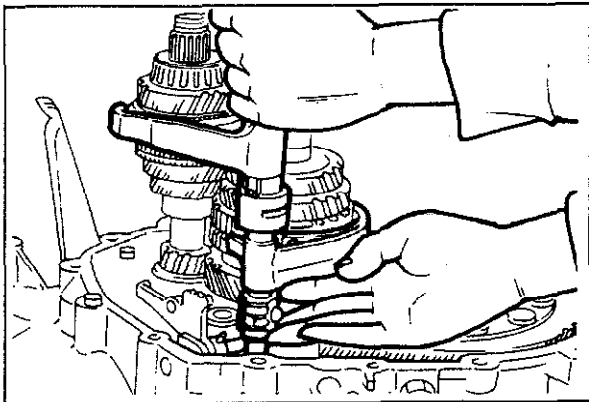

76U07A-227

### Shift Fork and Shift Rod Assembly

The shift fork and shift rod assembly can be removed as follows:

1. Align the ends of the interlock sleeve and of the control lever, then turn the shift rod counter-clockwise.
2. While holding the 1st - 2nd shift fork with one hand and the 3rd - 4th shift fork with the other, raise them both at the same time and shift each of the clutch hub sleeves.
3. Lift the control end and remove the steel ball, and, at the same time, remove the shift rod from the clutch housing.
4. Separate the shift rod and shift fork assembly from each of the clutch hub sleeves.

## DISASSEMBLY—STEP 2

Disassemble in the sequence shown in the figure.

76U07A-228

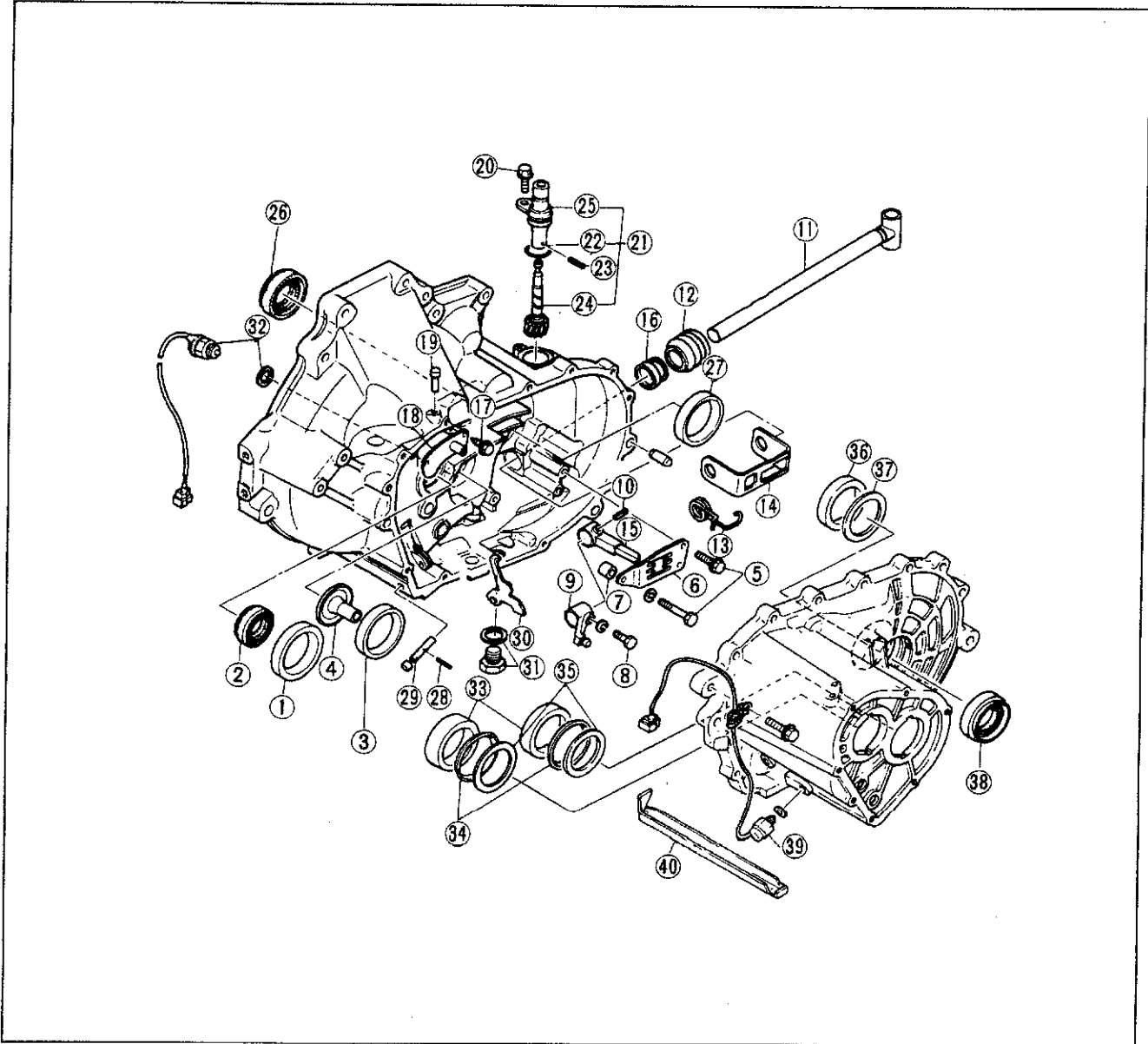

76U07A-229

- |                       |                                      |                               |
|-----------------------|--------------------------------------|-------------------------------|
| 1. Bearing outer race | 15. Selector                         | 28. Spring pin                |
| 2. Oil seal           | 16. Oil seal                         | 29. Reverse lever shaft       |
| 3. Bearing outer race | 17. Bolts                            | 30. Reverse lever             |
| 4. Funnel             | 18. Bleeder cover                    | 31. Drain plug and washer     |
| 5. Bolts              | 19. Bleeder                          | 32. Neutral switch and gasket |
| 6. Guide plate        | 20. Bolt                             | 33. Bearing outer race        |
| 7. Pipe               | 21. Speedometer driven gear assembly | 34. Diaphragm spring          |
| 8. Bolt               | 22. O-ring                           | 35. Adjust shim               |
| 9. Change arm         | 23. Spring pin                       | 36. Bearing outer race        |
| 10. Spring pin        | 24. Driven gear                      | 37. Adjust shim               |
| 11. Change rod        | 25. Gear case                        | 38. Oil seal                  |
| 12. Boot              | 26. Oil seal                         | 39. Back-up light switch      |
| 13. Spring            | 27. Bearing outer race               | 40. Oil passage               |
| 14. Reverse gate      |                                      |                               |

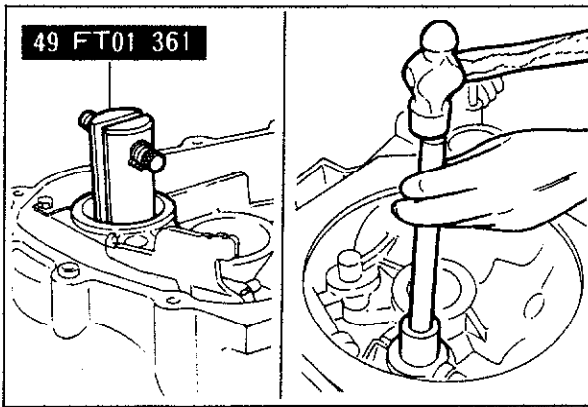

83U07A-012

**Bearing Outer Race (on engine side of primary shaft)**

Mount the **SST**, then reverse the clutch housing and use a piece of pipe to tap out the bearing outer race through the primary shaft hole.

**Caution**

**Before the bearing outer race comes all the way out, tap with lighter strokes and hold it to prevent it from falling.**

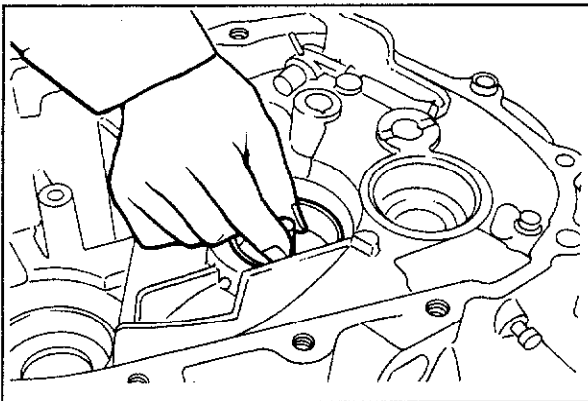

76U07A-049

**Bearing Outer Race (between secondary shaft and engine)**

Remove the bearing outer race by lifting out the funnel and the race together.

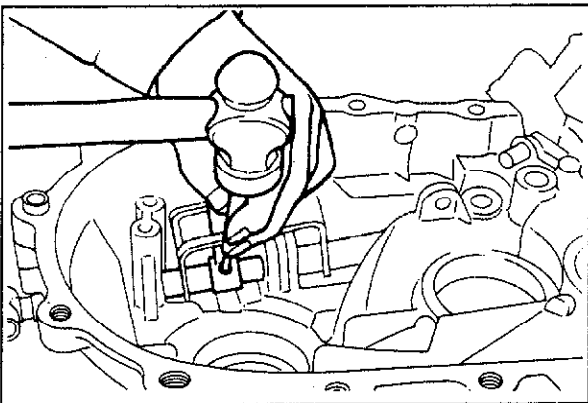

76U07A-231

**Spring Pin**

Align the groove for removal of the clutch housing pin with the position of the spring pin, then tap the pin out using a pin punch.

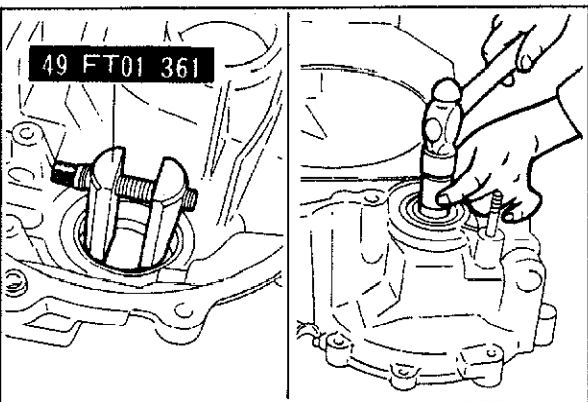

83U07A-013

**Bearing Outer Race (differential side)**

Mount the **SST**, then use a piece of pipe to tap out the bearing outer race through the driveshaft hole.

**Caution**

**Before the bearing outer race comes all the way out, tap with lighter strokes and hold it to prevent it from falling.**

# 7A DISASSEMBLY

## DISASSEMBLY—STEP 3

Disassemble in the sequence shown in the figure.

### Note

Replace the bearing inner race with a new one.

76U07A-233

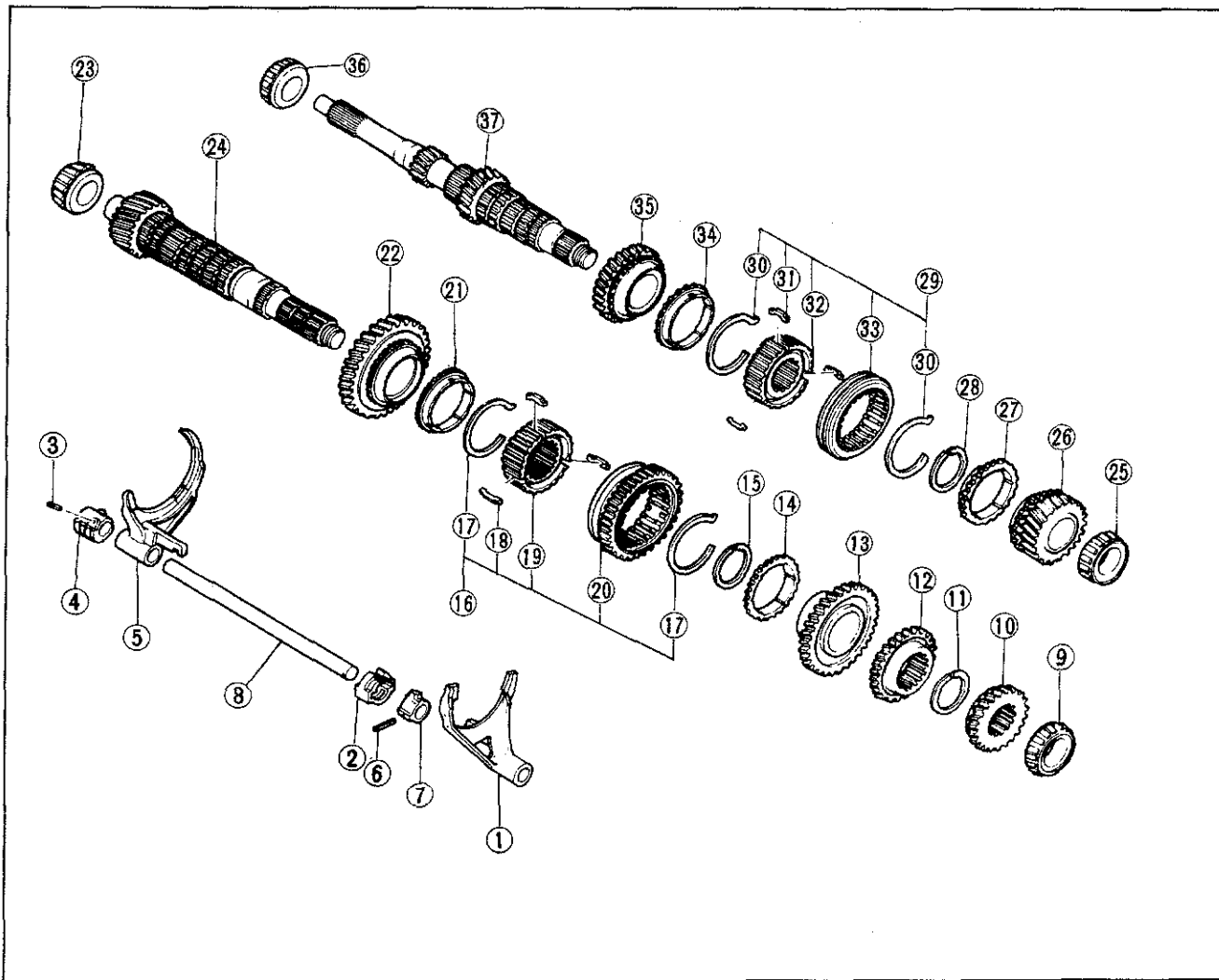

83U07A-014

- |                                   |                                      |   |
|-----------------------------------|--------------------------------------|---|
| 1. Shift fork (3rd and 4th gears) | 13. 2nd gear                         | 26. 4th gear                                |
| 2. Interlock sleeve               | 14. Synchronizer ring                | 27. Synchronizer ring                       |
| 3. Spring pin                     | 15. Retaining ring                   | 28. Retaining ring                          |
| 4. Control end                    | 16. Clutch hub assembly              | 29. Clutch hub assembly (3rd and 4th gears) |
| 5. Shift fork (1st and 2nd gears) | 17. Synchronizer spring              | 30. Synchronizer spring                     |
| 6. Spring pin                     | 18. Synchronizer keys                | 31. Synchronizer keys                       |
| 7. Control lever                  | 19. Clutch hub                       | 32. Clutch hub                              |
| 8. Control rod                    | 20. Clutch hub sleeve (reverse gear) | 33. Clutch hub sleeve                       |
| 9. Bearing outer race             | 21. Synchronizer ring                | 34. Synchronizer ring                       |
| 10. 4th gear                      | 22. 1st gear                         | 35. 3rd gear                                |
| 11. Retaining ring                | 23. Bearing inner race               | 36. Bearing inner race                      |
| 12. 3rd gear                      | 24. Secondary shaft                  | 37. Primary shaft                           |
|                                   | 25. Bearing inner race               |   |

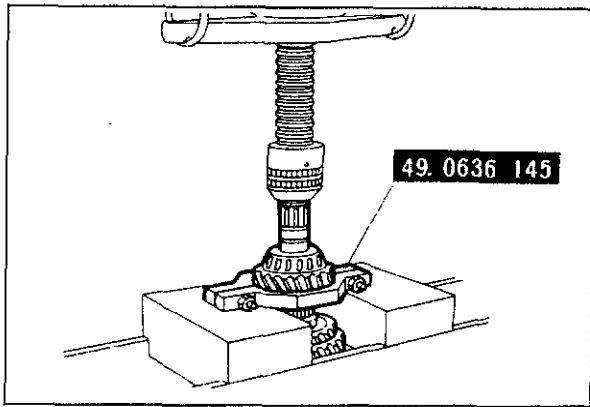

83U07A-015

## (SECONDARY SHAFT)

### Bearing Outer Race and 4th Gear

Press off the bearing outer race together with 4th gear using the **SST** on 4th gear.

#### Caution

Hold the shaft with one hand so that it doesn't fall.

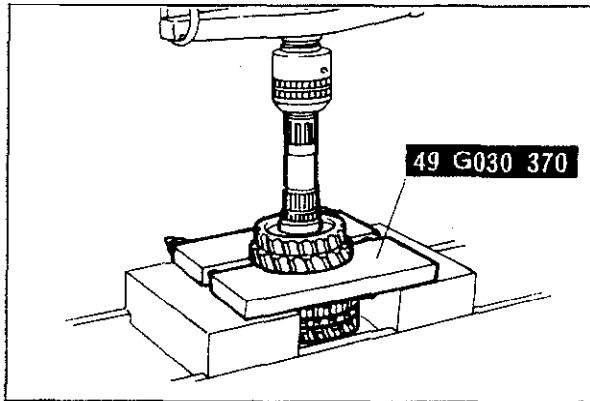

83U07A-016

### 3rd Gear

Press off 3rd gear together with 2nd gear using the **SST** on 2nd gear as shown.

#### Note

The clutch hub sleeve must be meshed with 1st gear.

#### Warning

Hold the shaft with one hand so that it doesn't fall.

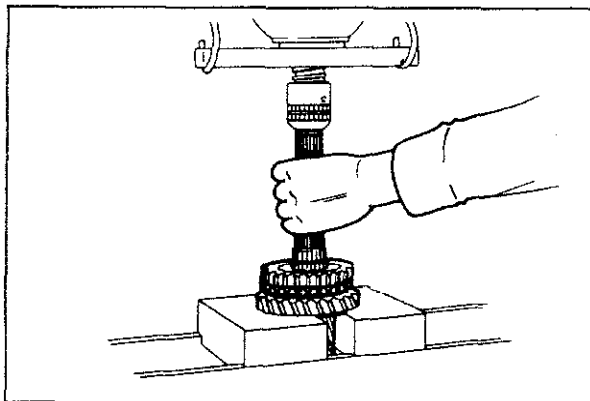

83U07A-017

### Clutch Hub Assembly (1st and 2nd gears)

Press off the 1st and 2nd clutch hub assembly by pushing against 1st gear. Remove it with the gears intact.

#### Caution

Hold the shaft with one hand so that it doesn't fall.

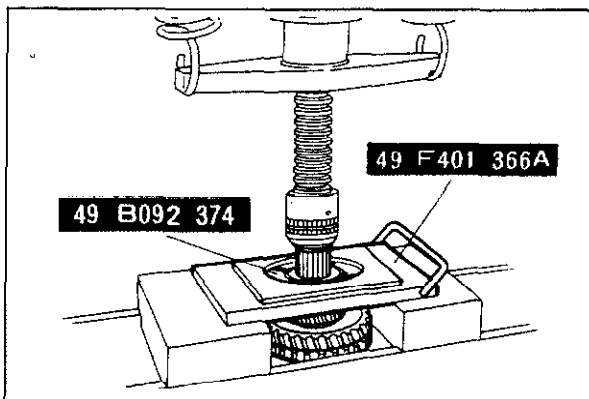

83U07A-018

### Bearing Inner Race (drive gear side)

Press the bearing inner race from the shaft using the **SST**.

#### Caution

Hold the shaft with one hand so that it doesn't fall.

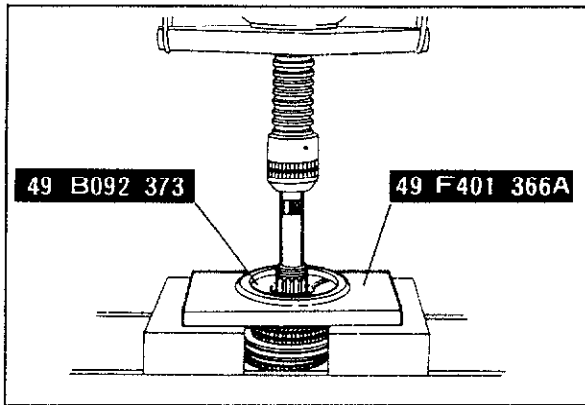

83U07A-019

## (PRIMARY SHAFT)

### Bearing Inner Race (4th gear side)

Press the bearing inner race from the shaft using the SST.

#### Caution

Hold the shaft with one hand so that it doesn't fall.

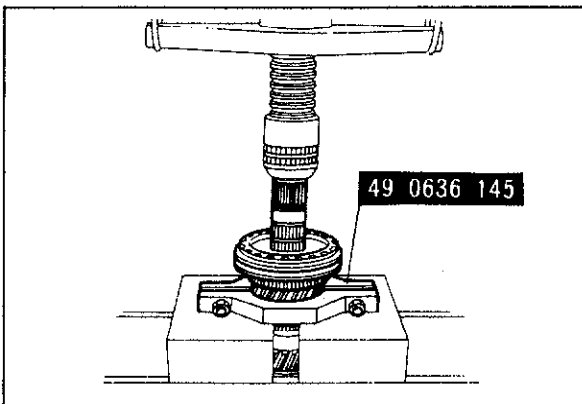

83U07A-020

### Clutch Hub Assembly (3rd and 4th gears)

Set the SST onto the 3rd gear, and press off the clutch hub assembly together with the gear.

#### Caution

Hold the shaft with one hand so that it doesn't fall.

## DIFFERENTIAL

Disassemble in the sequence shown in the figure.

#### Note

Replace the bearing inner race with a new one.

83U07A-021

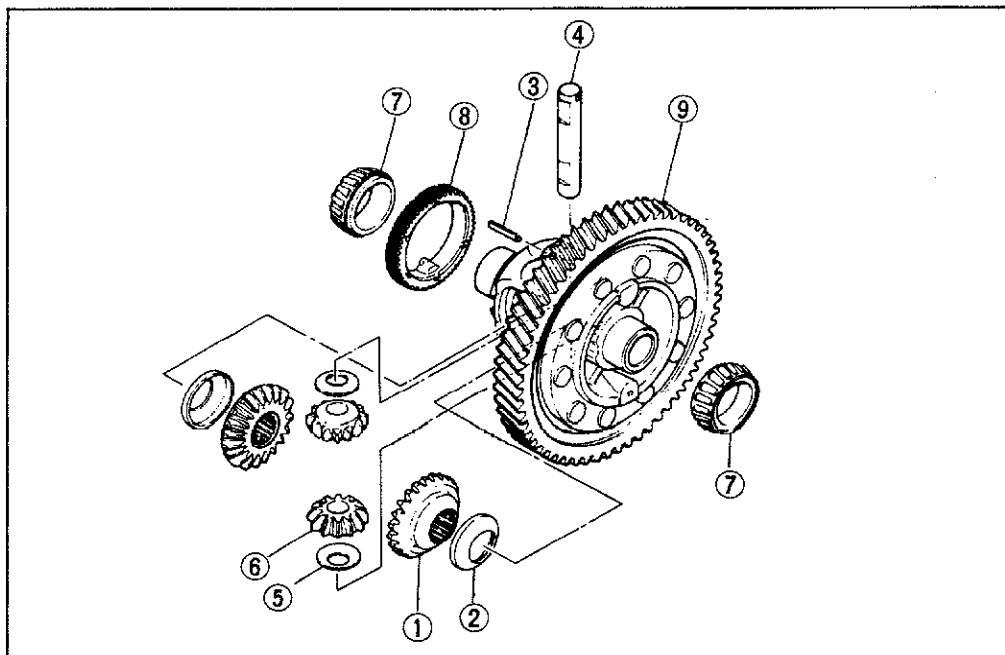

1. Side gears
2. Thrust washers
3. Spring pin
4. Pinion shaft
5. Thrust washers
6. Pinion gears
7. Side bearings
8. Speedometer drive gear
9. Ring gear and gear case assembly

73G07A-007

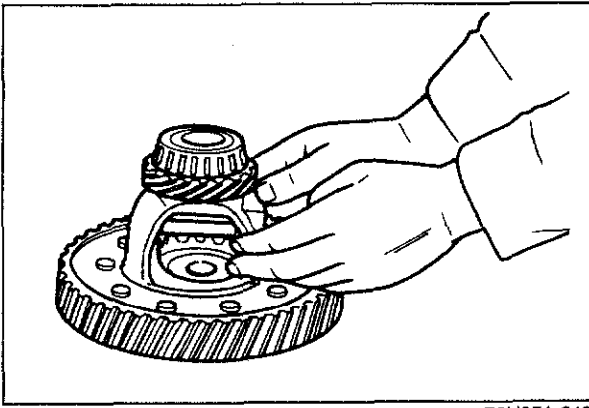

76U07A-243

### Side gear

Remove the side gear from the gear case, turning it backward on top of the pinion gear.

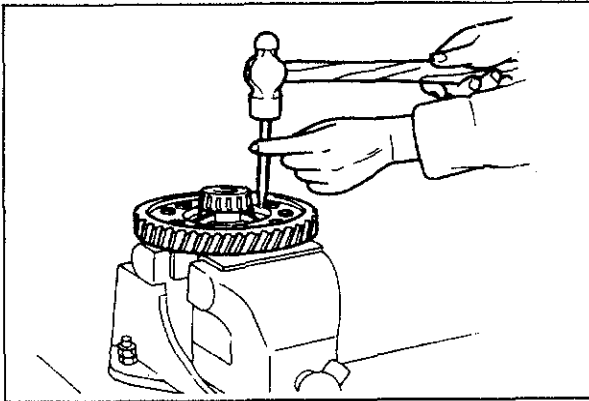

76U07A-063

### Spring pin

With the gear case secured in a vice, use a pin punch to tap out the spring pin.

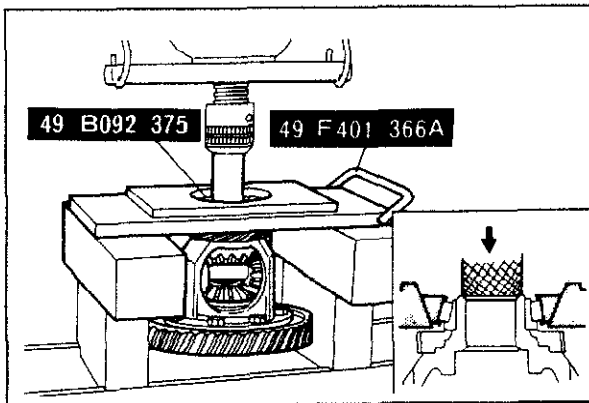

83U07A-022

### Side bearing inner race (side opposite the ring gear)

Remove the bearing inner race from the gear case using the **SST**.

#### Caution

Hold the gear case with one hand so that it doesn't fall.

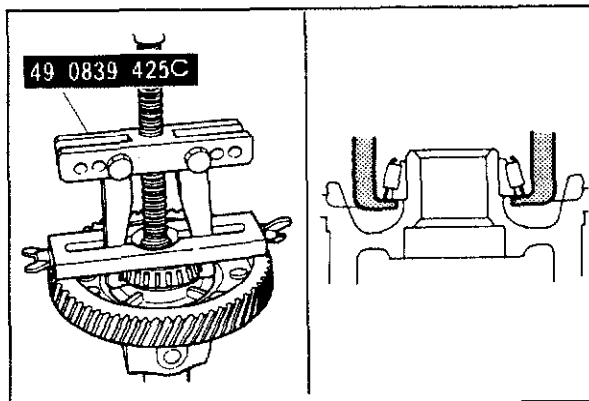

83U07A-066

### Side bearing inner race (ring gear side)

Remove the side bearing inner race using a combination of parts from the **SST**.

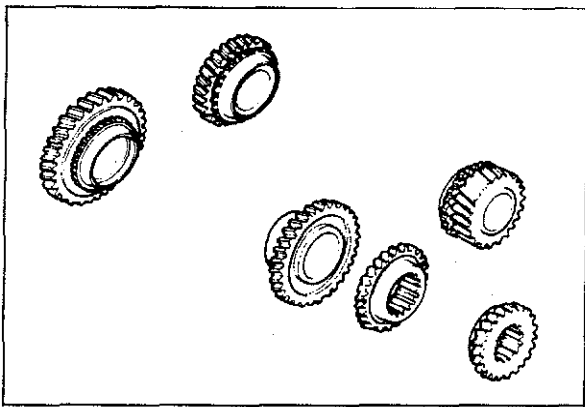

76U07A-244

## INSPECTION

Check the following parts, replace if necessary.

### 1st, 2nd, 3rd, 4th, and 5th Gears

1. Worn or damaged synchronizer cone.
2. Worn or damaged hub sleeve coupling.
3. Worn or damaged teeth.
4. Worn or damaged inner surface or end surface of gears.

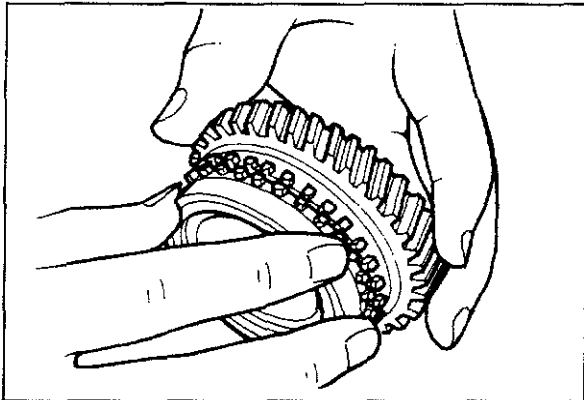

76U07A-245

### Primary Shaft Gear and Primary Gear (5-speed)

1. Worn teeth.
2. Worn or damaged sliding parts of each gear.
3. Worn or damaged spline.
4. Clogged oil passage.

#### Note

When the shaft gear is replaced, adjust the bearing preload.

### Synchronizer Ring

1. Engagement with gear.

#### Caution

If meshing is not good, coat the gear and the synchronizer ring contact surfaces with compound and repair by lapping.

2. Worn or damaged spline.
3. Worn or damaged tapered surface.
4. Clearance from the side of gear.

Standard: 1.5 mm (0.0591 in)

Min: 0.8 mm (0.0315 in)

#### Caution

a) Press the synchronizer ring uniformly against the gear and measure the overall circumference.

b) If the measured value is less than min., replace the synchronizer ring or gear.

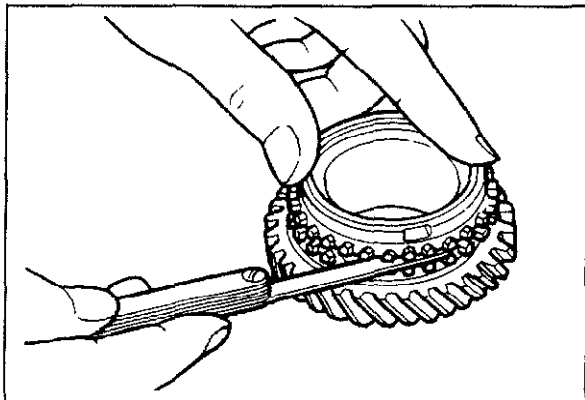

76U07A-246



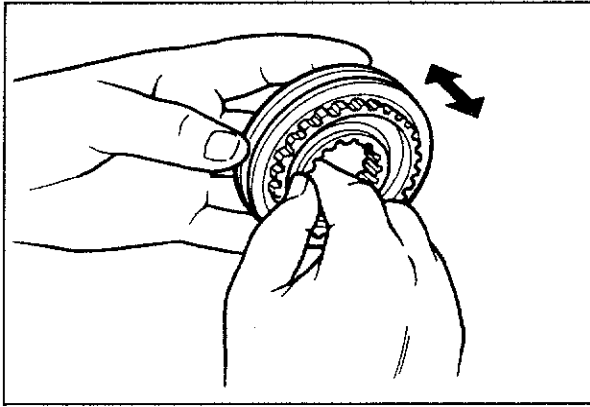

83U07A-023

**Secondary Shaft Gear**

1. Worn or damaged gear sliding parts.
2. Worn or damaged splines.
3. Worn teeth.
4. Clogged oil passage.

**Note**

**If the shaft gear is replaced, adjust the bearing preload.**

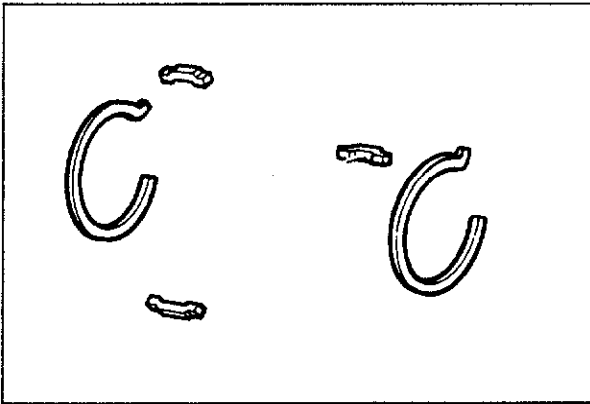

83U07A-024

**Clutch Hub**

1. Worn or damaged sleeve sliding surface.
2. Worn or damaged synchronizer key groove.
3. Worn end surface.
4. Operation of the hub sleeve when it is installed.

**Clutch Hub Sleeve**

1. Worn or damaged hub sliding surface.
2. Worn or damaged sleeve fork groove.

**Synchronizer Key and Spring**

1. Worn key.
2. Weak or bent spring.

**Reverse Idle Gear**

1. Worn or damaged bushing.
2. Worn or damaged teeth.
3. Worn or damaged release lever coupling groove.

**Clutch housing, Transaxle case, Rear cover, and Differential Gear Case**

1. Cracks or damage.

**Note**

**If the clutch housing, transaxle case, or differential gear case are replaced, adjust the bearing preload of each shaft gear and the preload of the differential side bearing.**

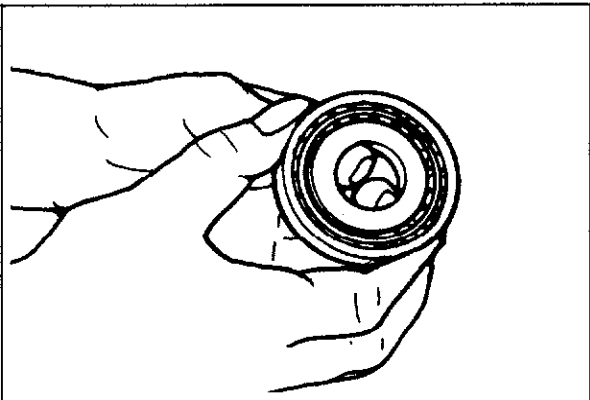

83U07A-025

**Bearing**

1. Roughness or noise while turning.
2. Worn or damaged outer race or roller.

**Note**

- a) **Replace the bearing, the outer race, and the inner race as a unit.**
- b) **If the bearing is replaced, adjust the preload.**

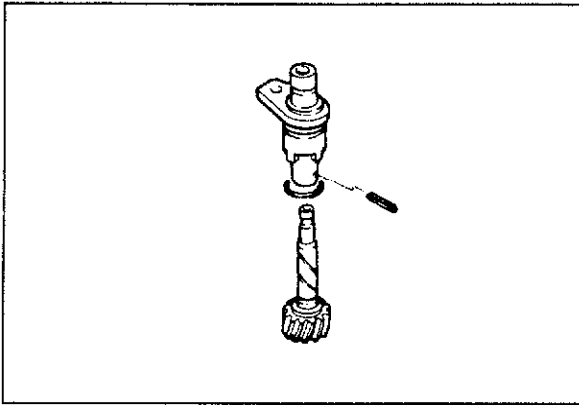

76U07A-250

## Ring Gear and Speedometer Drive Gear

1. Worn or damaged teeth.

### Note

If the ring gear is faulty, replace the entire ring gear and gear case assembly.

### Oil Seal

1. Deformed, damaged, or worn lip.

### Speedometer Driven Gear Assembly

1. Worn or damaged teeth.
2. Worn or damaged O-ring.

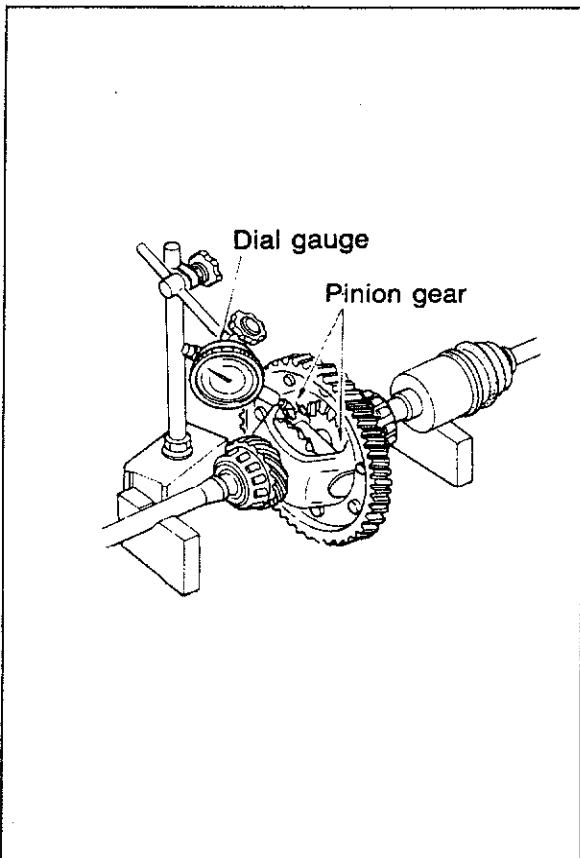

76U07A-251

## Backlash of Side Gear and Pinion Gear

Check and adjust using the following procedure.

1. Install the driveshaft and the joint shaft onto the differential assembly.
2. Support the shafts on V-blocks as shown.
3. Measure the backlash of both pinion gears.

**Backlash: 0—0.1 mm (0—0.0039 in)**

4. If the backlash exceeds specification, replace all the thrust washers with new ones.

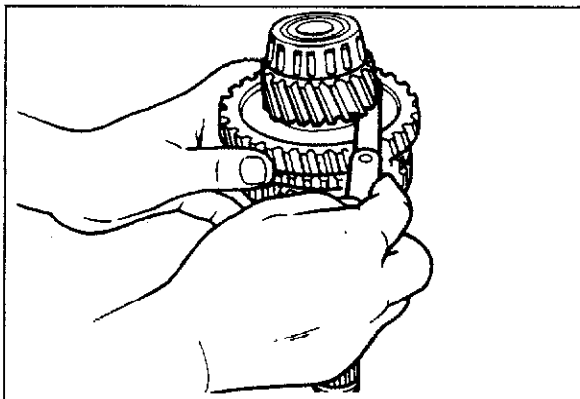

76U07A-252

## Thrust Clearance of 1st, 2nd, 3rd, and 4th Gears

### Note

Measure either before disassembling the shaft gear assembly or while assembling it.

1. Measure the clearance between 1st gear and the differential drive gear on the secondary shaft.

**Standard: 0.05—0.28 mm (0.0020—0.0110 in)**  
**Max: 0.33 mm (0.019 in)**

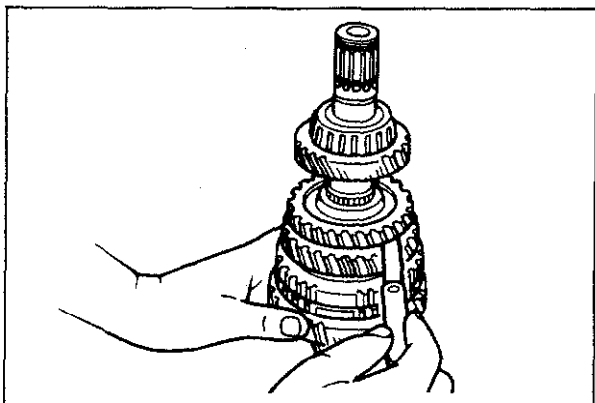

76U07A-253

2. Measure the clearance between 2nd gear and 3rd gear.

**Standard:**

**0.175—0.455 mm (0.0069—0.0179 in)**

**Max: 0.505 mm (0.0199 in)**

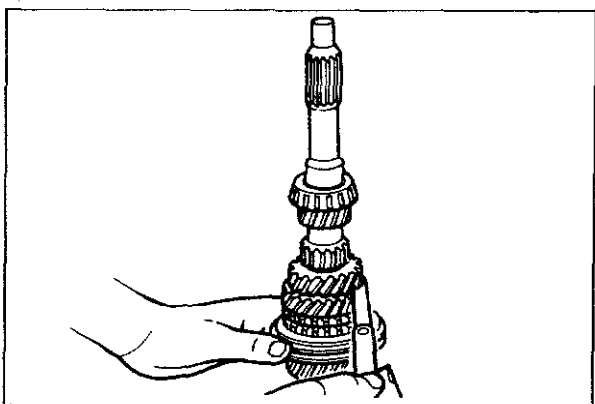

76U07A-254

3. Measure the clearance between 3rd gear and 2nd gear.

**Standard: 0.05—0.20 mm (0.0020—0.0079 in)**

**Max: 0.25 mm (0.0098 in)**

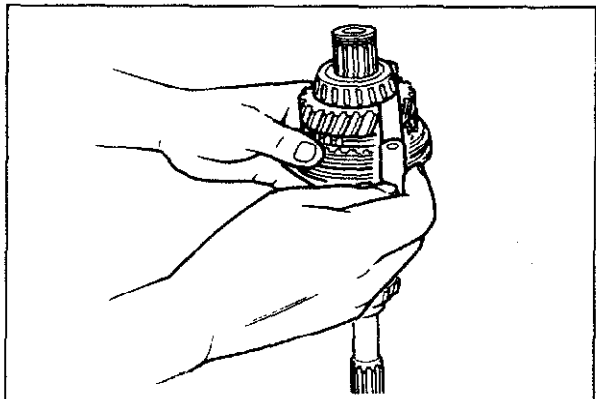

76U07A-255

4. Measure the clearance between 4th gear and the bearing inner race.

**Standard:**

**0.165—0.365 mm (0.0064—0.0144 in)**

**Max: 0.415 mm (0.0163 in)**

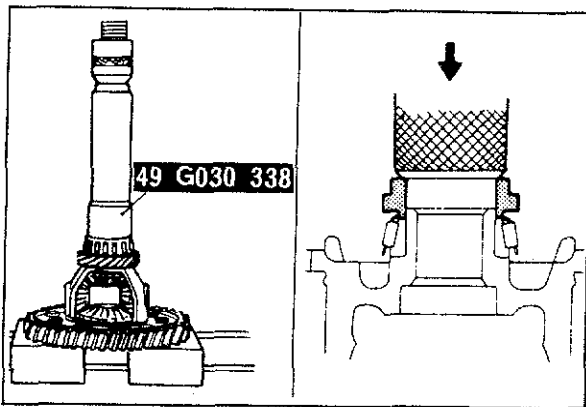

83U07A-026

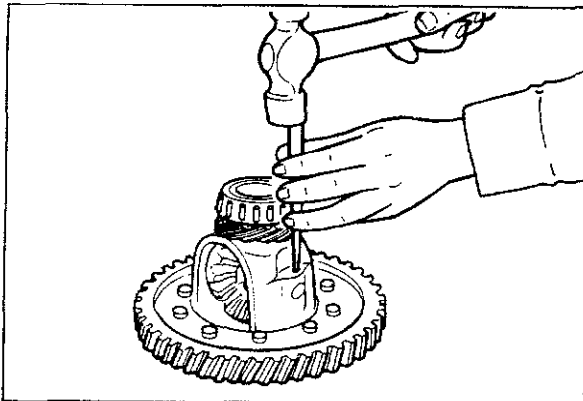

76U07A-257

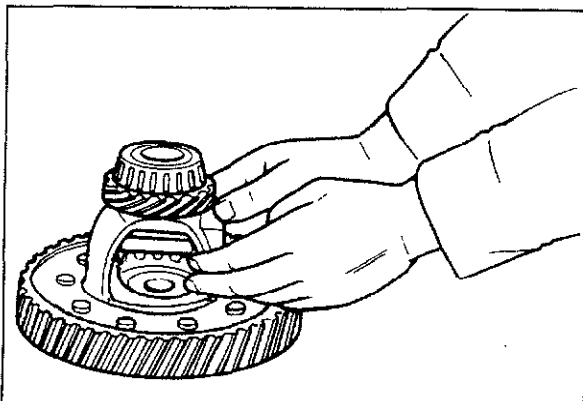

76U07A-080

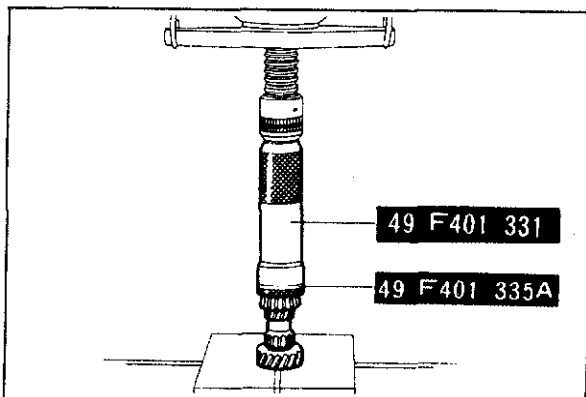

83U07A-027

## ASSEMBLY

### Caution

- a) Clean each part before installing it.
- b) Before installation, coat sliding surfaces of the bearings and gears with transaxle oil.
- c) Be sure to use new spring pins and retaining rings.

### Differential

1. Install the speedometer drive gear into the gear case.
2. Support the ring gear, and press on the side bearing inner race using **SST**.

### Note

**Press on until there is no gap between the bearing and the gear case.**

3. Install the thrust washer onto the pinion gear, then install both into the gear case and install the pinion shaft.
4. Tap the spring pin into the gear case from the speedometer gear side.

5. After installing thrust washers onto the side gears, place the two side gears into the gear case at the same time, turn them back on the pinion gear and install them into the gear case.

### Primary Shaft Gear

1. Support 2nd gear, then press on the bearing outer race (engine side) using the **SST**.

### Note

**Press on until there is no gap between the primary shaft and the bearing.**

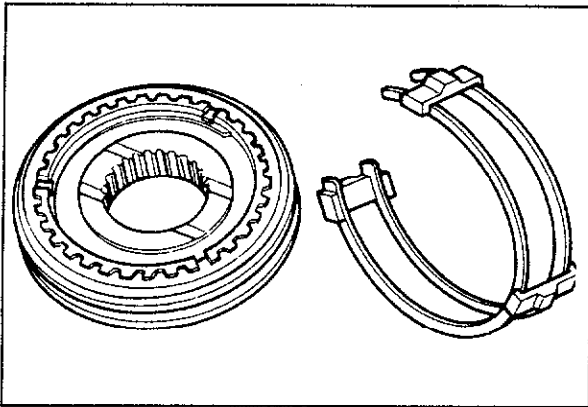

76U07A-082

2. Install the clutch hub and 3 synchronizer keys into the clutch hub sleeve (3rd and 4th gears).
3. Fit the hook of the synchronizer key spring into the clutch hub groove for the hook, and install the 3 synchronizer keys so that they are held down.
4. Install 3rd gear onto the shaft gear.

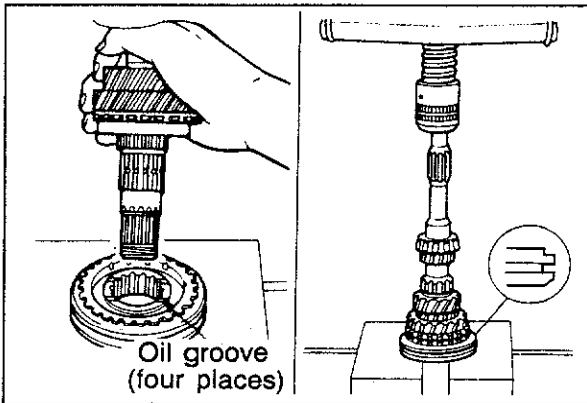

73G07A-008

5. Install the synchronizer ring onto the clutch hub assembly.
6. Place the clutch hub assembly so that it faces in the direction shown in the figure and press on the shaft gear.

**Note**  
Install the clutch hub sleeve as shown.

**Caution**  
Begin pressing only after confirming that the splines of the shaft gear and the clutch hub are properly positioned, and press until the force applied reaches 19.620 N (4,409 lb).

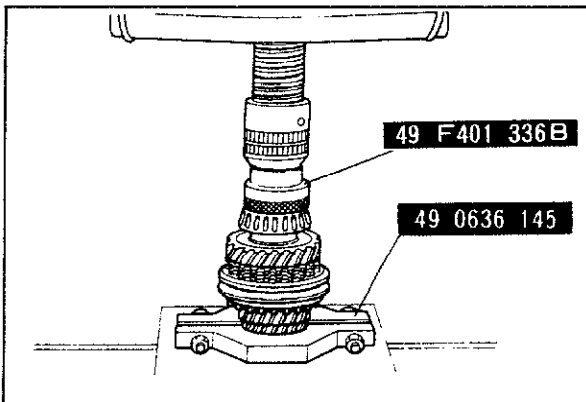

83U07A-028

7. Install the retaining ring, the synchronizer ring, and 4th gear onto the shaft gear in that order.
8. Install the 2nd gear using the **SST**.

**Note**  
Press on until there is no gap between the shaft and the bearing.

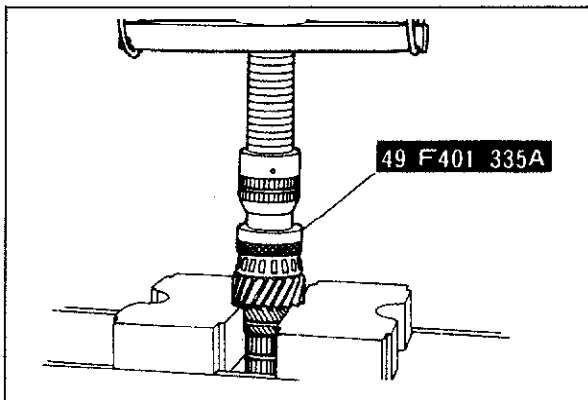

83U07A-029

### Secondary Shaft Gear

1. Support the drive gear, and press on the bearing inner race using **SST**.

**Note**  
Press on until there is no gap between the shaft and the bearing.

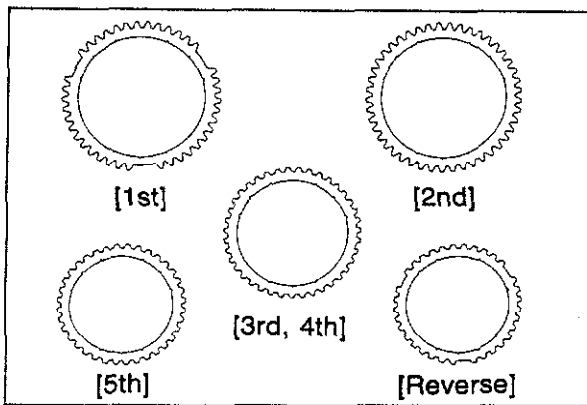

76U07A-086

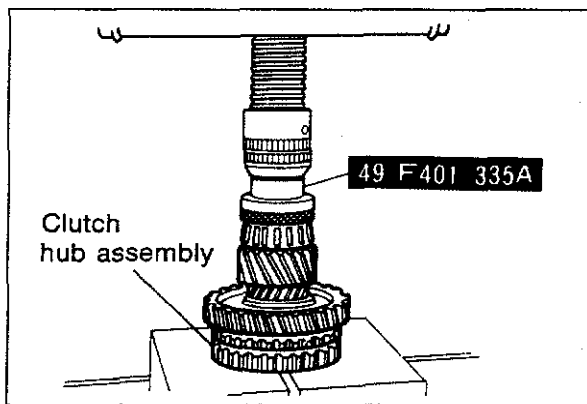

83U07A-030

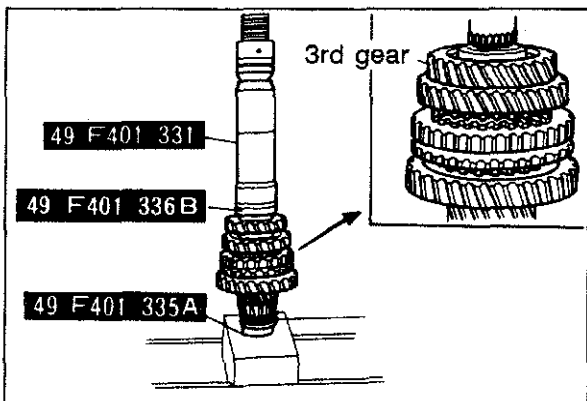

83U07A-031

2. Install the clutch hub and the 3 synchronizer keys into the clutch hub sleeve (1st and 2nd gears).
3. Fit the hook of the synchronizer key spring into the clutch hub groove for the hook, and install the 3 synchronizer keys so that they are held down.
4. Install 1st gear onto the shaft gear.

### Note

The styles and size of the synchronizer rings are different as shown in the illustration.

5. Install the synchronizer ring onto the clutch hub assembly.
6. Place the clutch hub assembly so that it faces in the direction shown in the figure and press in the shaft gear.
7. Press the clutch hub assembly onto the shaft gear using **SST**.

### Note

Begin pressing only after confirming that the splines of the shaft gear and the clutch hub are properly positioned, and press until the force applied reaches 19,620 N (4,409 lb).

8. Install the retaining ring, the synchronizer ring, and 2nd gear onto the shaft gear in that order.
9. Support the bearing inner race of the shaft gear using **SST**.
10. Press 3rd gear onto the shaft gear using the **body** (49 F401 331) and **attachment B** (49 F401 336B) of the **bearing installer**.

### Note

- a) Install 3rd gear so that it faces in the direction shown in the figure.
- b) Press only after confirming that the splines of the shaft gear and 3rd gear are properly positioned, and press until the force applied reaches 29,430 N (6,614 lb).

11. Install the retaining ring onto the shaft gear.

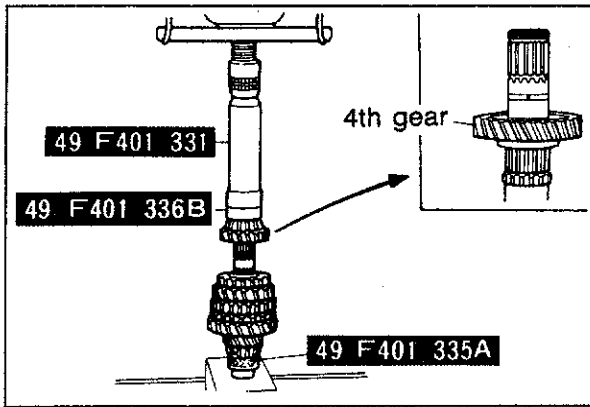

83U07A-032

12. Support the bearing inner race of the shaft gear using **SST**.
13. Install 4th gear and the bearing inner race onto the shaft gear.
14. Position the **SST** in place on the bearing inner race, and press on the bearing inner race and 4th gear at the same time.

### Note

- a) Install 4th gear so that it faces in the direction shown in the figure.
- b) Begin pressing only after confirming that the splines of the shaft gear and 4th gear are properly aligned, and press in until there is no gap between the shaft and the bearing inner race.

### Bearing Preload

Adjust the bearing preload through the use of adjust shim(s).

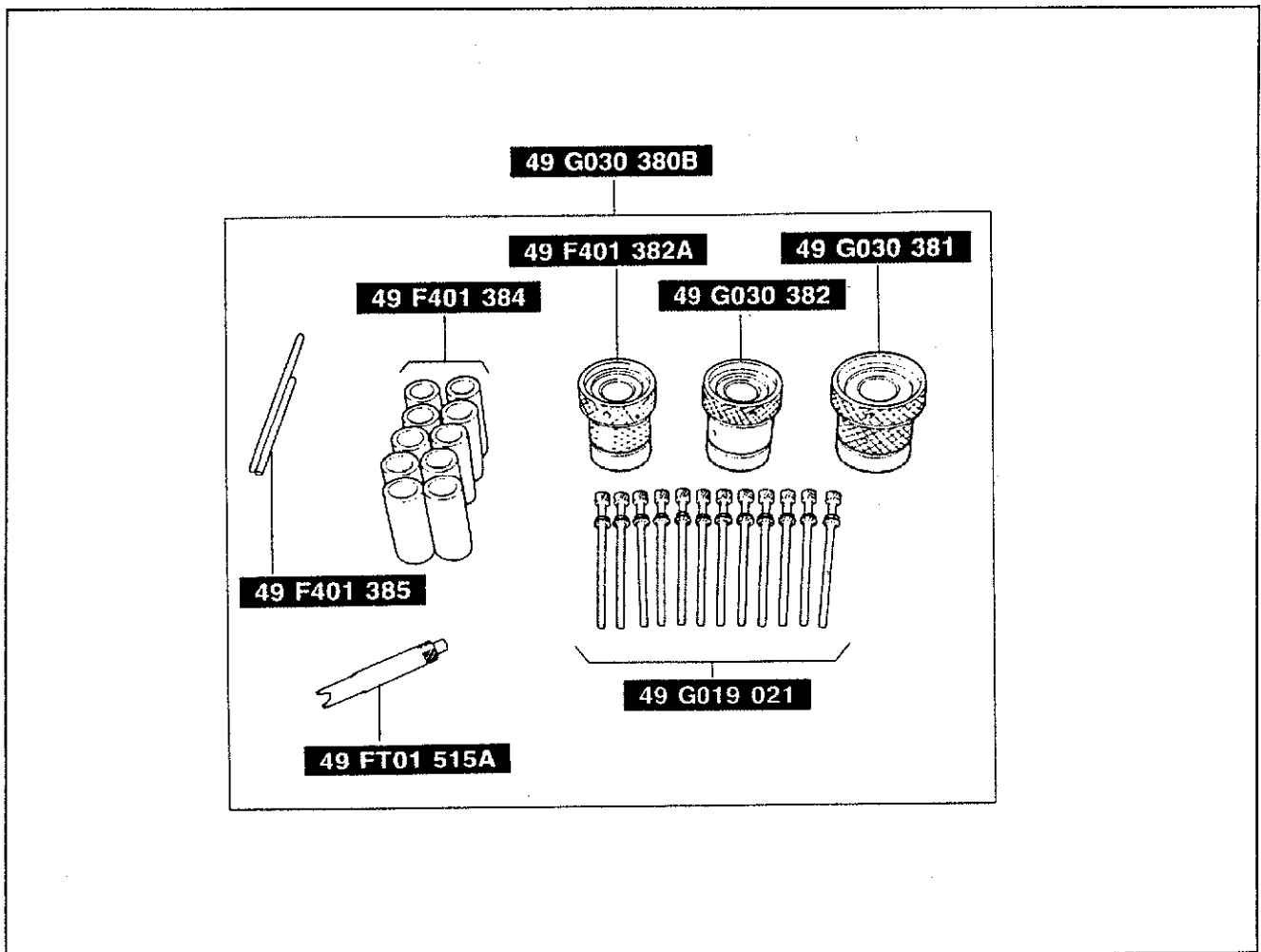

83U07A-099

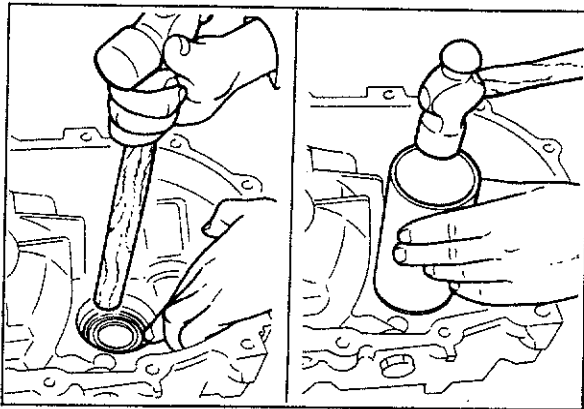

83U07A-087

1. Install the primary and secondary bearing outer races into the transaxle case (shims removed).
2. Mount the clutch housing on the transaxle hanger, and install the differential bearing outer race with brass drift until it is flush with the clutch housing.
3. Position a piece of pipe [outer diameter 68 mm (2.68 in) or less] against the differential bearing outer race and tap with a hammer until it contacts the clutch housing.

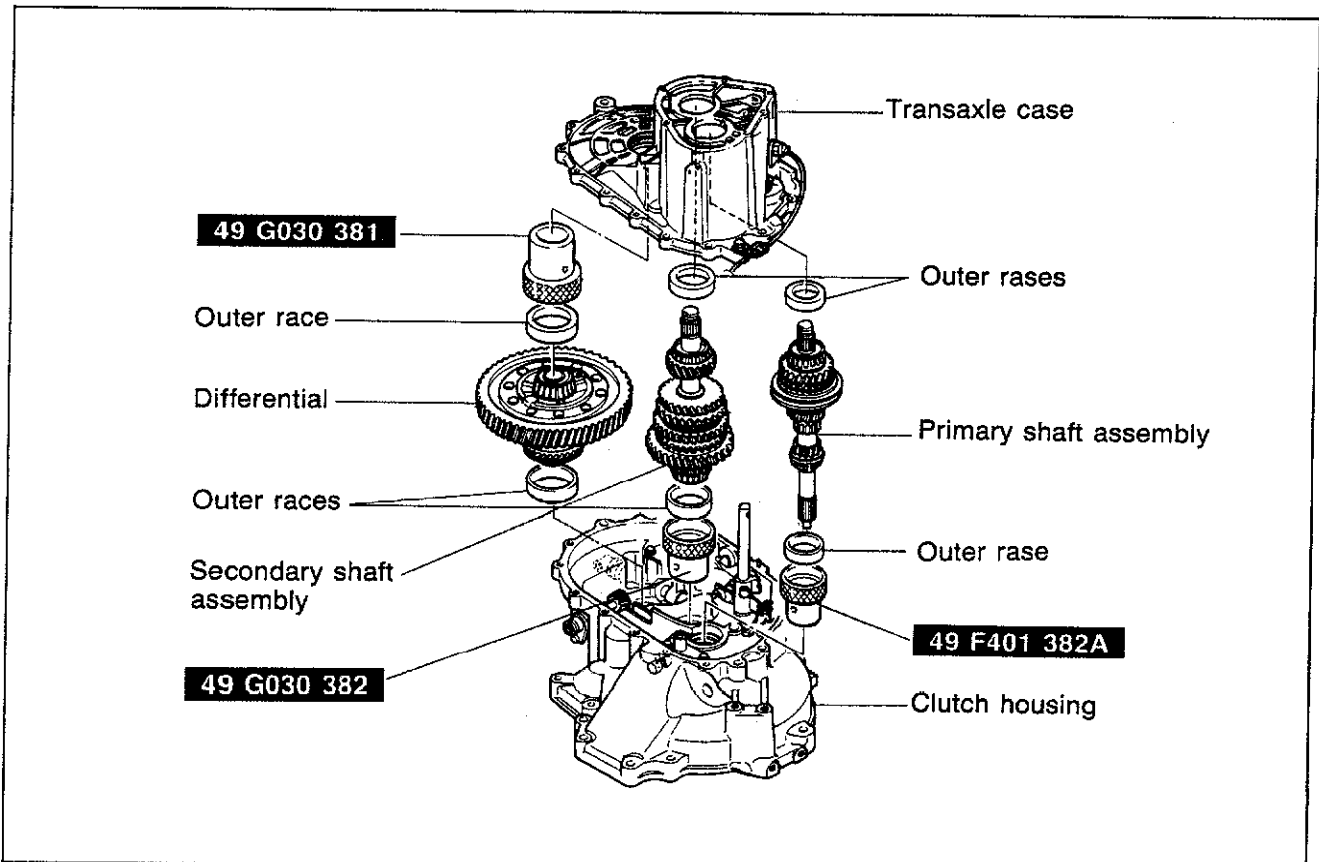

83U07A-033

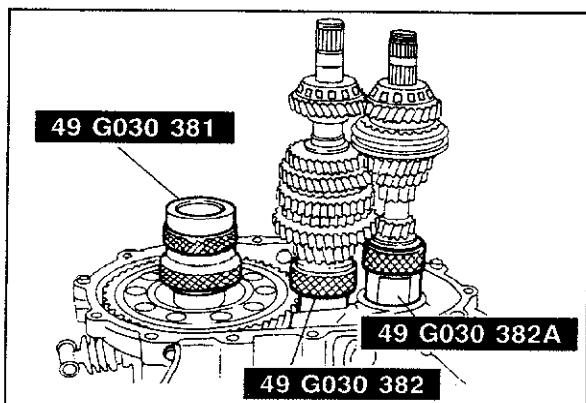

83U07A-095

4. Install the outer races into the **SST**.
5. Mount the differential assembly to the clutch housing, and mount the assembled selector and bearing outer race on the differential.
6. Mount the assembled selector and bearing outer race for primary and for secondary shaft into the clutch housing.
7. Mount both shaft gear assemblies as shown.



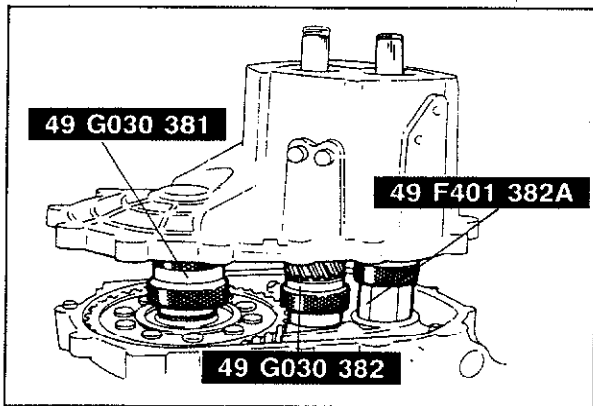
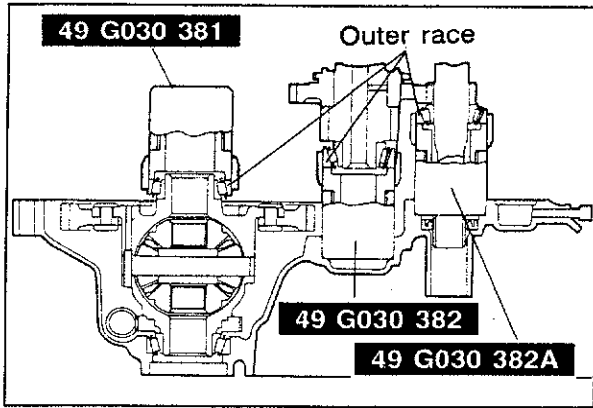

76U07A-267

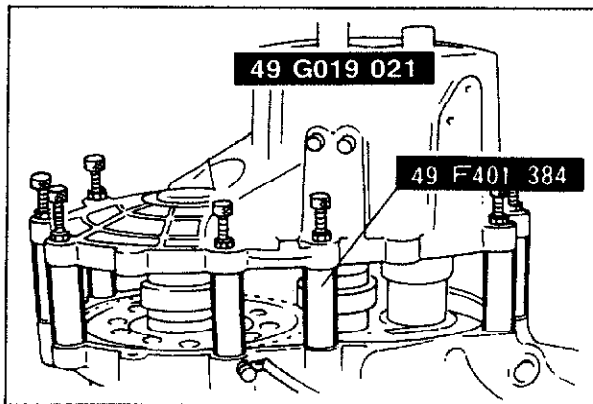

83U07A-088

8. Mount the transaxle case to the shafts and the differential selector as shown.

9. Set the **SST** between the transaxle case and the clutch housing, then install the **SST** and tighten to the specified torque.

**Tightening torque:**

18—20 N·m (1.8—2.0 m·kg, 13—14 ft·lb)

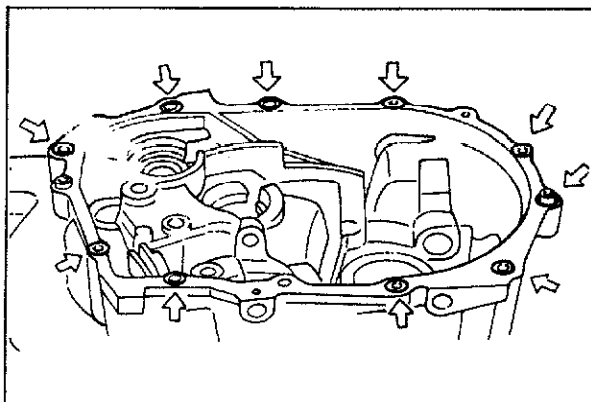

83U07A-034

**Note**  
Install the collars at the positions shown in the figure.

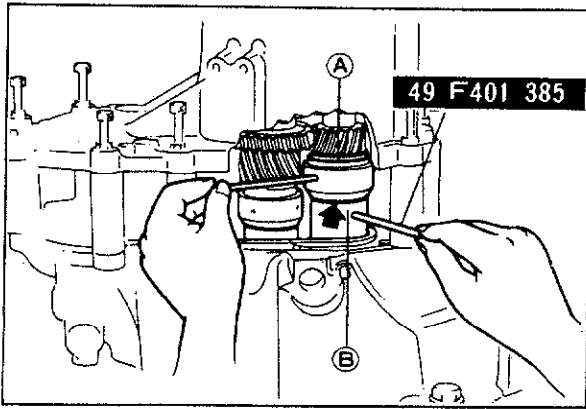

83U07A-089

10. To seat the bearings, mount the **SST** on parts (A) and (B) of the selector, and turn the selector so the gap shown by the arrow in the figure is widened.
11. Move the bar by hand until the selector can no longer be turned, and turn it in the reverse direction until the gap is eliminated.

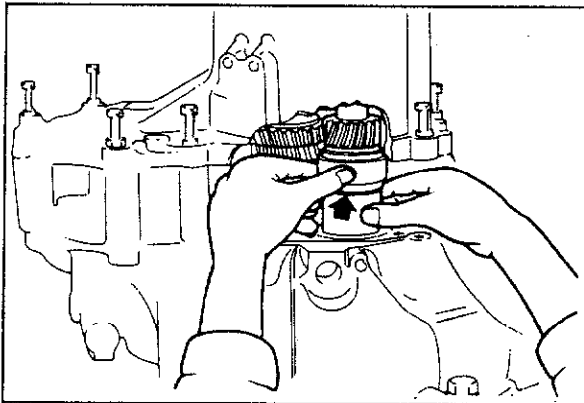

83U07A-035

12. Manually expand the selector without the bars for both shafts until the selector no longer turns.

**Note**

**Make sure that each shaft gear turns smoothly.**

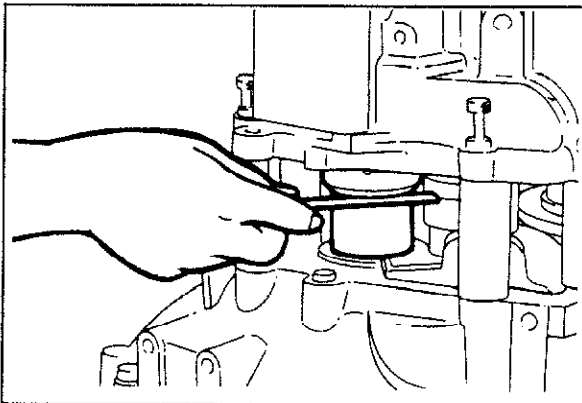

83U07A-036

13. Use a feeler gauge to measure the gap in the selector at each shaft gear.

**Note**

**Measure the gap around the entire circumference of the selector.**

14. Select an appropriate adjust shim.

- (1) The shim to be used at the **primary shaft** gear side should be selected by referring to the table and selecting the shim which is nearest (on the thin side) to the value obtained by subtracting the thickness of the diaphragm spring [**0.70 mm (0.0276 in)**] from the largest measured value **(A)**.

**Example:**

$$\begin{aligned} \text{(A)} &= 0.94 \text{ mm (0.037 in)} \\ &0.94 \text{ mm (0.0370 in)} - 0.70 \text{ mm (0.0276 in)} \\ &= 0.24 \text{ mm (0.0094 in)} \end{aligned}$$

**So the nearest shim (on the thin side) to 0.24 mm (0.0094 in) is 0.20 mm (0.0079 in).**

- (2) The shim to be used at the **secondary shaft** gear side should be selected by referring to the table and selecting the shim which is nearest (on the thin side) to the value obtained by subtracting the thickness of the diaphragm spring [**0.70 mm (0.0276 in)**] from the largest measured value **(B)**.

Thickness	
0.20 mm (0.0079 in)	0.50 mm (0.0197 in)
0.25 mm (0.0098 in)	0.55 mm (0.0217 in)
0.30 mm (0.0118 in)	0.60 mm (0.0236 in)
0.35 mm (0.0138 in)	0.65 mm (0.0256 in)
0.40 mm (0.0157 in)	0.70 mm (0.0276 in)
0.45 mm (0.0177 in)	

83U07A-037

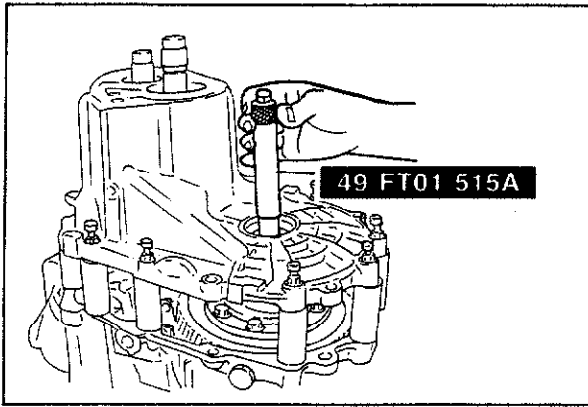

83U07A-038

**Example:**

(B) = 0.94 mm (0.037 in)  
 0.94 mm (0.037 in) - 0.70 mm (0.0276 in)  
 = 0.24 mm (0.0094 in)  
 So the nearest shim (on the thick side) to 0.24 mm (0.0094 in) is 0.25 mm (0.0098 in).

**Note**

The number of shims used must not be more than two.

15. Install the **SST**.

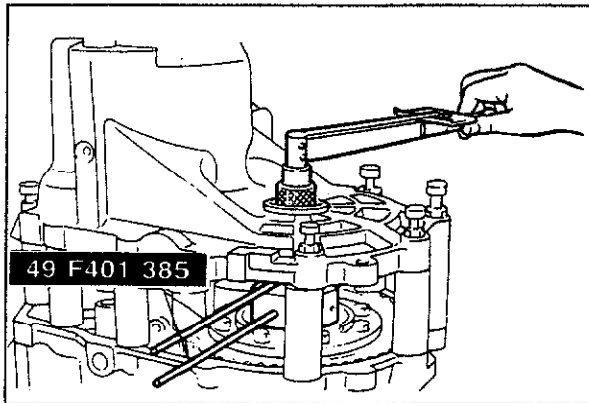

83U07A-090

16. Adjust the selector with the **SST** until the preload specification is obtained.

**Preload: 0.5 N·m (5 cm·kg, 4.3 in·lb)**

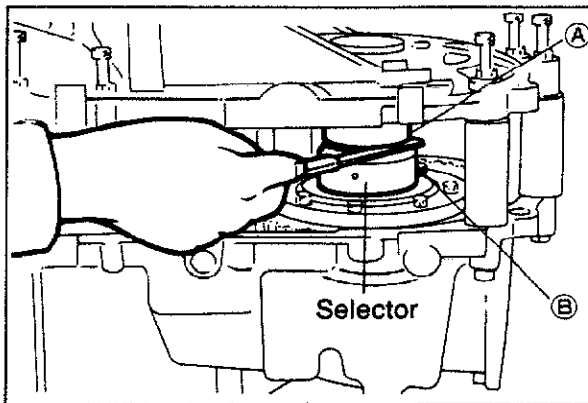

83U07A-039

17. Measure the clearance between (A) and (B) with a feeler gauge.

18. Add **0.15 mm (0.0059 in)** to the measured clearance and select the combination of shims closest in value to that measurement.

See the table below for available shim sizes.

**Note**

a) Measure the gap around the entire circumference of the selector

b) The number of shims used must not be more than three.

Thickness	
0.1 mm (0.0039 in)	0.9 mm (0.0354 in)
0.2 mm (0.0079 in)	1.0 mm (0.0394 in)
0.3 mm (0.0118 in)	1.1 mm (0.0433 in)
0.4 mm (0.0157 in)	1.2 mm (0.0472 in)
0.5 mm (0.0197 in)	0.12 mm (0.0047 in)
0.6 mm (0.0236 in)	0.14 mm (0.0055 in)
0.7 mm (0.0276 in)	0.16 mm (0.0063 in)
0.8 mm (0.0315 in)	

83U07A-040

19. Remove the **SST**, and remove the transaxle case. Remove the shaft gears, selectors, and the differential.

20. Remove the bearing outer races for both shafts from the transaxle case. Leave the differential side bearing outer race in the clutch housing.

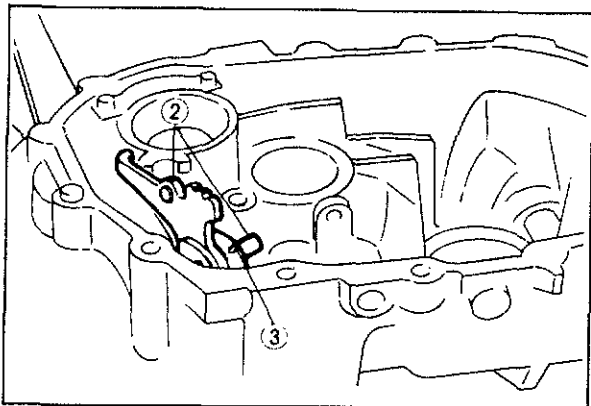

76U07A-105

## Clutch Housing

1. Install the drain bolt and washer.
2. Install the reverse lever, and secure it with the reverse lever shaft.

### Note

Align the shaft with the spring pin coupling hole in the clutch housing.

3. Tap in a new spring pin.

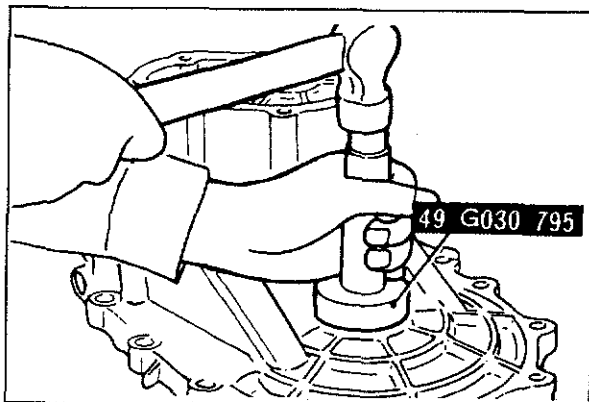

83U07A-091

4. Tap in the oil seal (differential side) using the **SST**.
5. Install the bleeder.
6. Install the bleeder cover.
7. Install the oil seal (change rod side).

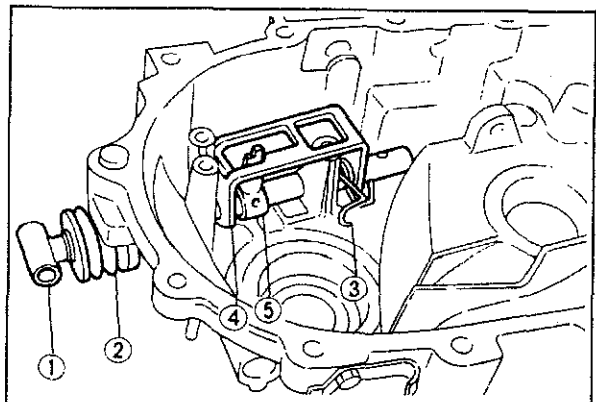

76U07A-275

8. Install the change rod (1), the boot (2), the spring (3), the reverse gate (4), and the selector (5), as shown.

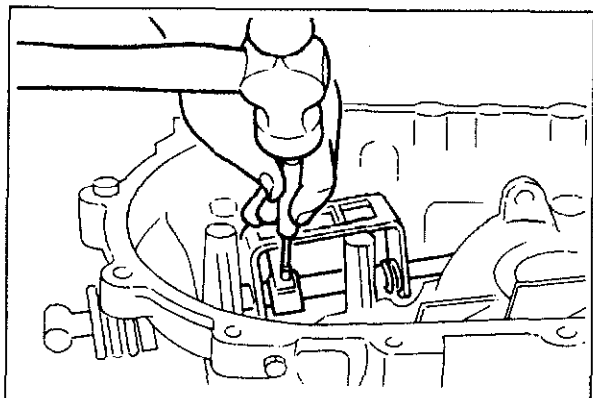

76U07A-276

9. Align the change rod and spring pin coupling hole in the selector, then tap in a new spring pin.

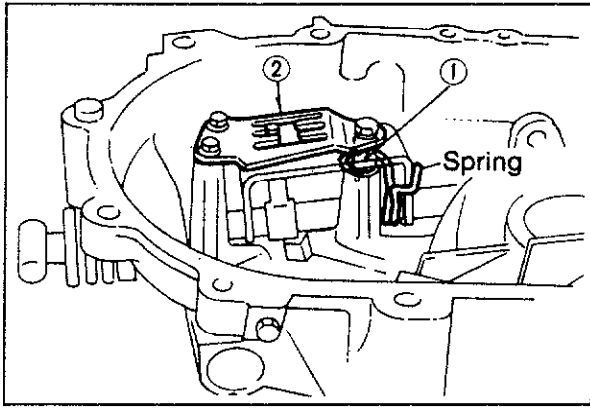

76U07A-109

10. Install the pipe (1) and the guide plate (2), and temporarily tighten the bolts.

**Note**

**Set the spring as shown.**

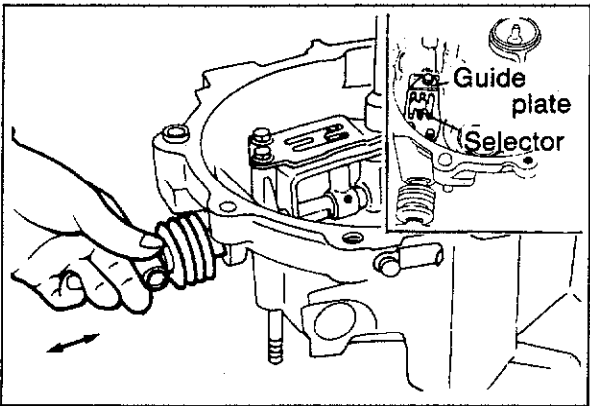

76U07A-277

11. Install the change arm onto the change rod, and secure it with the bolt.  
Install the shift control rod and detent ball and spring, and select neutral position.
12. Install the crankshaft lever and the crankshaft lever shaft, and secure the shaft to the housing with the pin.
13. Push and pull the change rod and move the guide plate so that the selector moves smoothly in the grooves of the guide plate. Then tighten the guide plate mounting bolts.
14. Remove the control rod, ball, spring and pin.  
Remove the crankshaft lever shaft and the crankshaft lever.
15. Install the funnel and the bearing outer race into the secondary shaft gear bearing bore of the clutch housing.
16. Install the oil seal and the bearing inner race into the primary shaft gear bearing bore of the clutch housing.

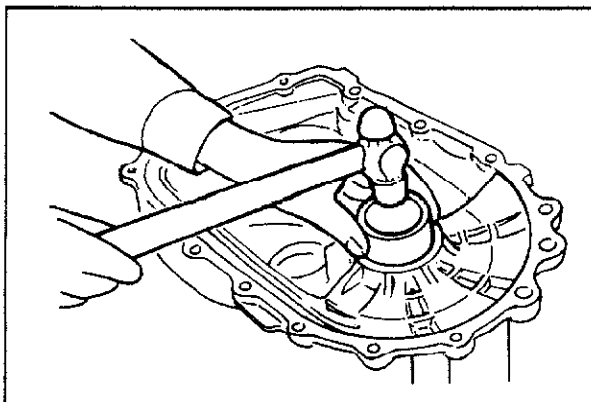

76U07A-278

**Transaxle Case**

1. Install the oil passage and tighten the bolt.
2. Install the back-up light switch.
3. Install the selected adjust shim into the differential side bearing bore of the transaxle case.
4. Tap the bearing outer race with a hammer handle until it is flush with the end of the transaxle case.
5. Tap in the outer races until the edges contact the clutch housing, using a piece of pipe (outer diameter **68 mm (2.68 in)** or less) and a hammer.

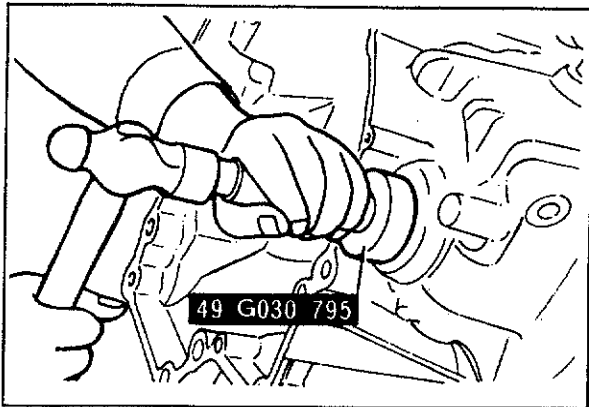

83U07A-096

6. Tap in the oil seal using the **SST**.

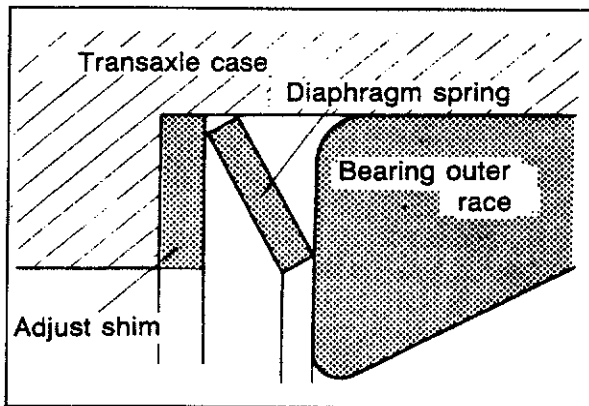

73G07A-014

7. Install the previously selected adjustment shims and the diaphragm springs in the direction shown in the figure, and install the bearing outer races.

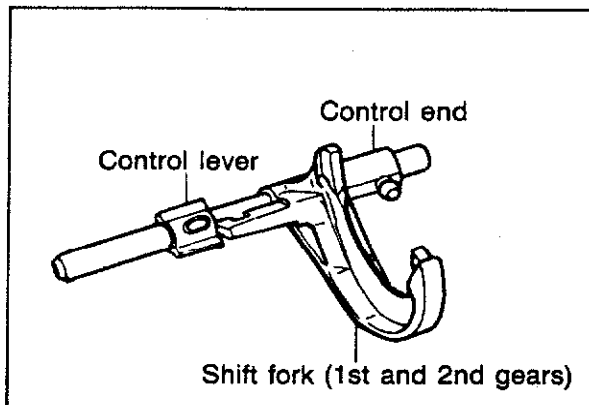

76U07A-114

### Shift Fork and Shift Rod

1. Install the control lever onto the control rod, align each of the spring pin coupling holes, and tap in new spring pins.
2. Install the shift fork (1st and 2nd gears) and the control end onto the control rod so that they face in the direction shown in the figure, align the control end and the spring pin hole in the rod, and tap in the new spring pin.

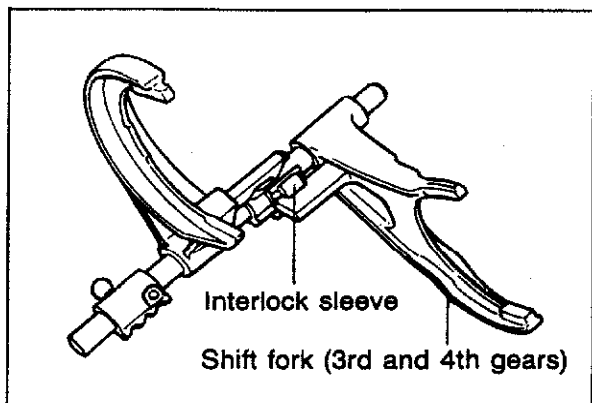

73G07A-015

3. Assemble the shift fork (1st and 2nd gears), the interlock sleeve and the shift fork (3rd and 4th gears).

### Note

The dot on the interlock sleeve must face toward the 3rd gear and the shift fork.

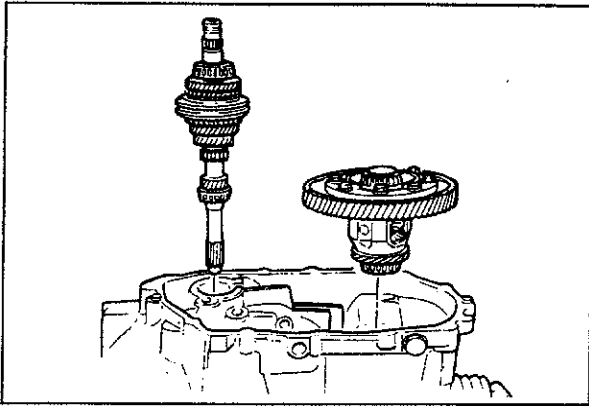

73G07A-016

## Bearing Preload

Check the shaft gears and the differential bearing preload.

### Note

- a) Check that the correct adjust shims were selected.
- b) If the bearing preload is not within specification, adjust again.

1. Set the primary shaft gear and the differential into the clutch housing.
2. Install the transaxle case, and tighten to the specified torque.

**Tightening torque: 37—52 N·m  
(3.8—5.3 m·kg, 27—38 ft·lb)**

3. Install the **SST**.
4. Measure the preload.

**Preload: 1.4—2.0 N·m  
(14—20 cm·kg, 12.2—17.5 in·lb)**

5. Remove the **SST**.

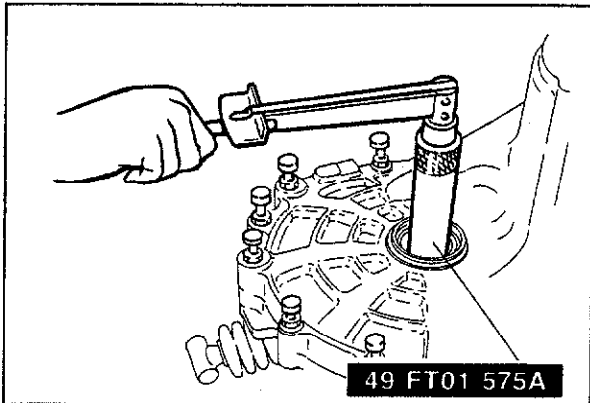

83U07A-100

6. With the transaxle facing in the direction shown in the figure, install the **SST** to the primary shaft gear.
7. Measure the preload.

**Preload: 0.1—0.25 N·m  
(1.0—2.5 cm·kg, 0.87—2.18 in·lb)**

### Note

**Extend the handle fully and hook the pull scale to the end of the handle.**

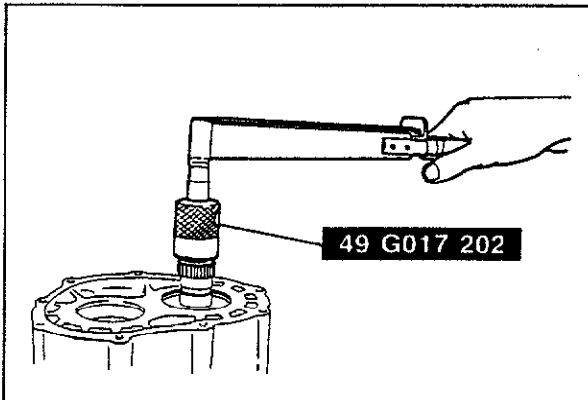

83U07A-101

8. Remove the **SST**, transaxle case, primary shaft gear and differential.
9. Install the secondary shaft gear and transaxle case then tighten to the specified torque.

**Tightening torque: 18—26 N·m  
(1.8—2.7 m·kg, 13.0—18.8 ft·lb)**

10. Check the secondary shaft preload with the **SST**.

**Preload: 0.2—0.4 N·m  
(2.0—4.0 cm·kg, 1.7—3.4 in·lb)**

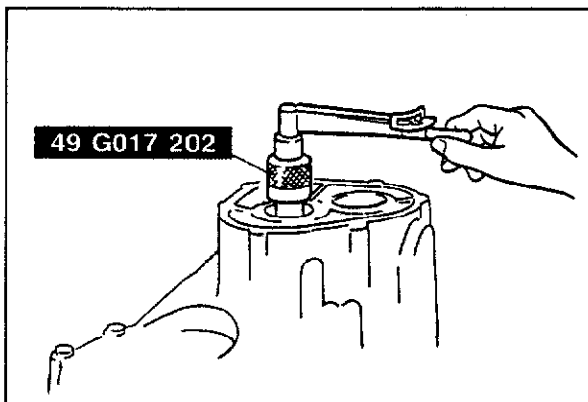

86U07A-101

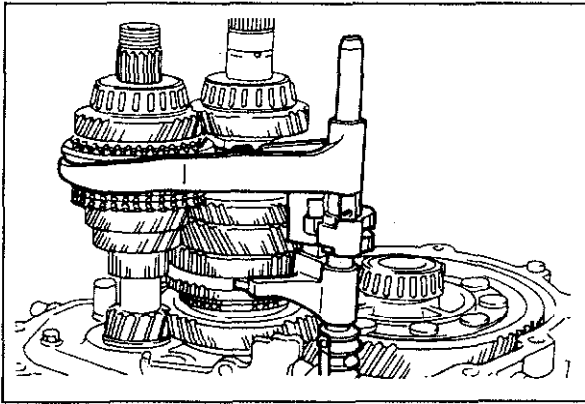

73G07A-020

1. Remove the transaxle case and shaft gears.
2. Shift the clutch hub sleeve (secondary shaft gear) to 2nd gear and the clutch hub sleeve (primary shaft gear) to 4th gear.
3. Position the shift fork and shift rod assembly as shown and install the shift fork into each hub sleeve.

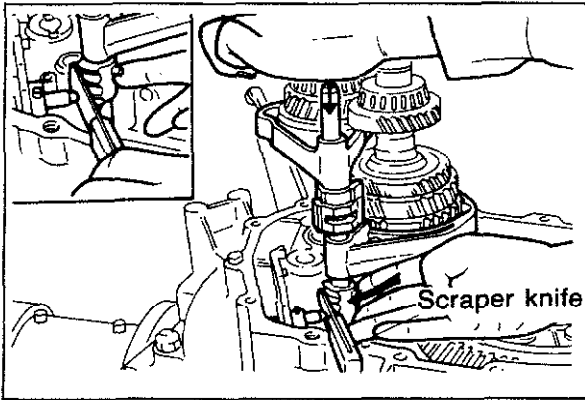

76U07A-284

4. Insert the spring seat and spring into the reverse lever shaft, install the steel ball, and place a scraper knife so that it contacts the steel ball.
5. With the edge of the control end against the knife, when the control end is pushed in the direction of the arrow in the figure so that the ball goes into the shaft, the rod will at the same time line up with the shift rod coupling hole in the clutch housing.

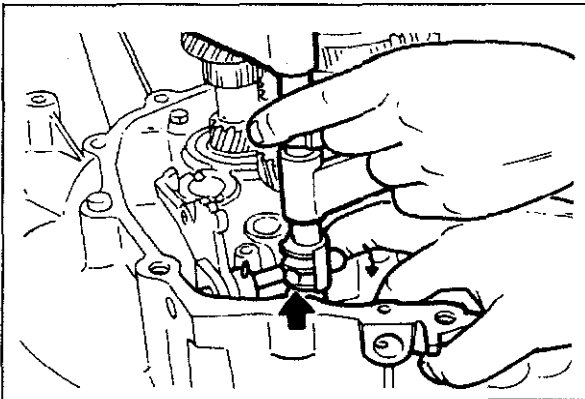

76U07A-119

6. Set each clutch hub sleeve to the neutral position, and tap the shift rod from above so that the steel ball goes into the center groove (of the 3 grooves in the control end).
7. Pull the ball part of the control end forward so that the steel ball goes into the detent in the groove.

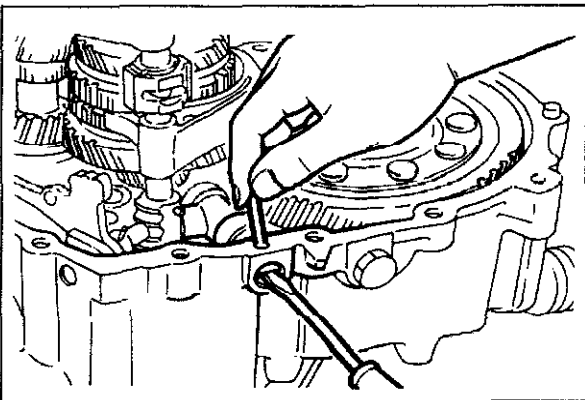

76U07A-285

8. Fit the crank lever in between the change arm and the control end, and connect the crank lever shaft to the crank lever.
9. Align the pin holes of the crank lever shaft and the clutch housing, and insert the pin.

### Caution

**Use a new O-ring for the crank lever shaft.**



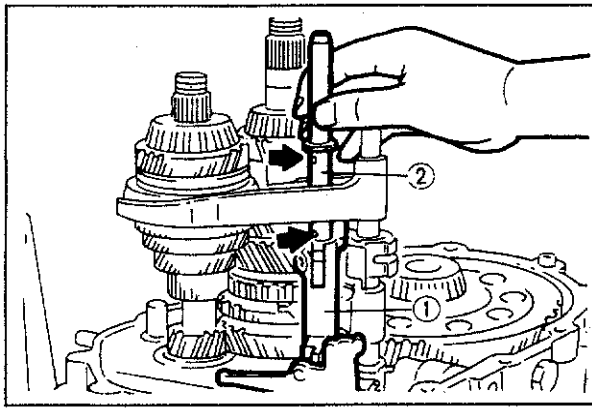

76U07A-121

- 10 Install the gate (1) and the shift rod (2), and tighten the gate mounting bolt.

**Note**

The mark (indicated by the arrow in the figure) and the gate mounting bolt hole must be in the same direction.

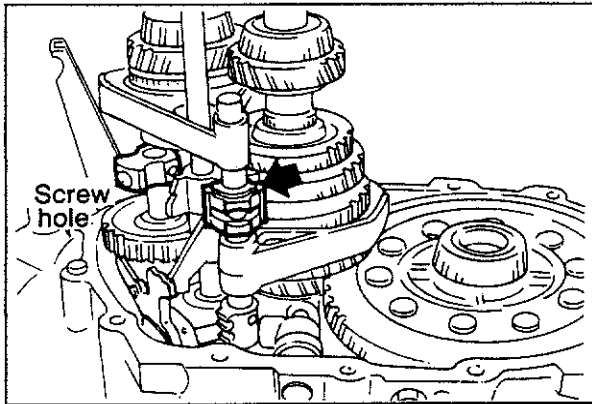

76U07A-122

- 11 Install the reverse idle gear and the reverse idle shaft.  
 12. Connect the magnet to the clutch housing.  
 13. Align the end of the interlock sleeve with the control lever indicated by the arrow, and, at the same time, face the reverse idle shaft screw hole in the direction shown in the figure.

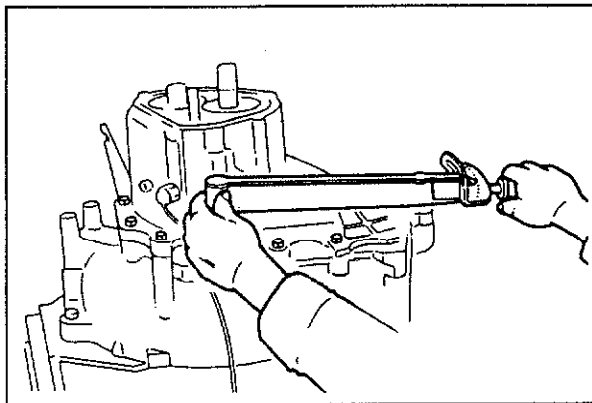

73G07A-031

14. Apply a thin coat of sealant to the contact surfaces of the clutch housing and transmission case, tighten the transaxle case installation bolts to the specified torque.

**Tightening torque:**

**37—52 N·m (3.8—5.3 m·kg, 27—38 ft·lb)**

**Caution**

a) Apply sealant after cleaning the contact surfaces of the clutch housing and transaxle case.

b) Insert the preload adaptor (49 G030 455) into the driveshaft coupling hole.

If this is not done, the side gear will turn on the pinion gear within the differential gear case, and it might become necessary to disassemble the transaxle again. Leave this adaptor inserted until installation of the driveshaft.

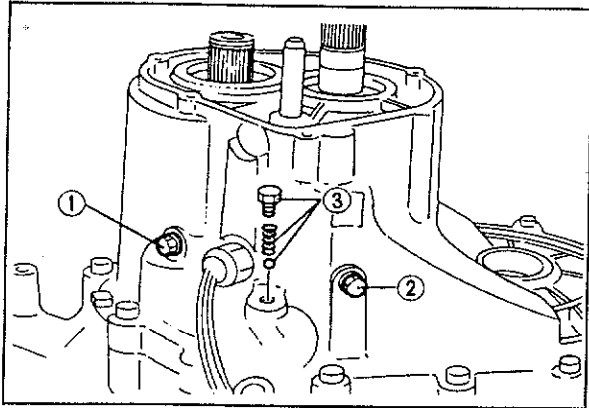

83U07A-092

## 5th Gear and Rear Cover

1. Install the lock bolt (1) and the guide bolt (2), and install the ball, spring and the lock bolt (3).

### Caution

After installation, move the change rod to check that the gear change operation is smooth.

### Tightening torque:

- ① 18—26 N·m  
(1.8—2.6 m·kg, 13—19 ft·lb)
- ② 9—14 N·m  
(90—140 cm·kg, 78—162 in·lb)
- ③ 15—21 N·m  
(150—210 cm·kg, 173—242 in·lb)

2. Position the secondary 5th gear on the secondary shaft gear in the direction shown in the figure.

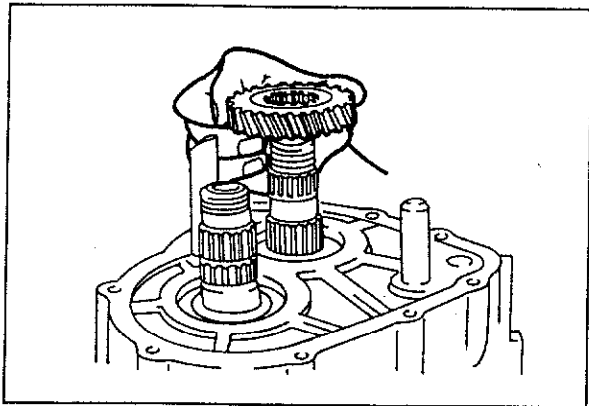

73G07A-022

3. Install the clutch hub and the 3 synchronizer keys to the clutch hub sleeve (5th gear).
4. Insert the hook part of the synchronizer key spring into the groove for the hook in the clutch hub.
5. Install the spring so that the 3 synchronizer keys are secured.

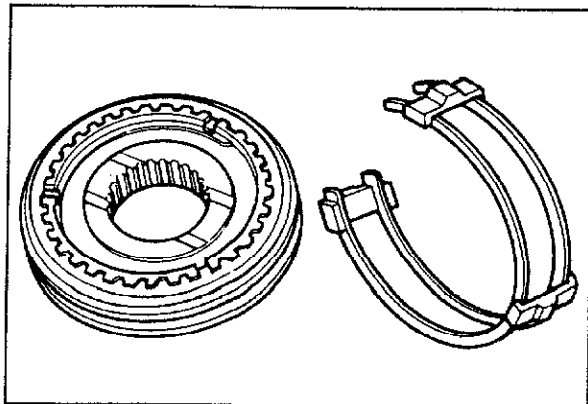

76U07A-126

6. Install the gear sleeve onto the primary shaft gear, then connect the 5th gear and synchronizer ring.
7. Install the shift fork to the clutch hub assembly, and install them together as shown.

### Caution

Install the clutch hub assembly and shift fork so that they face in the direction indicated in the figure.

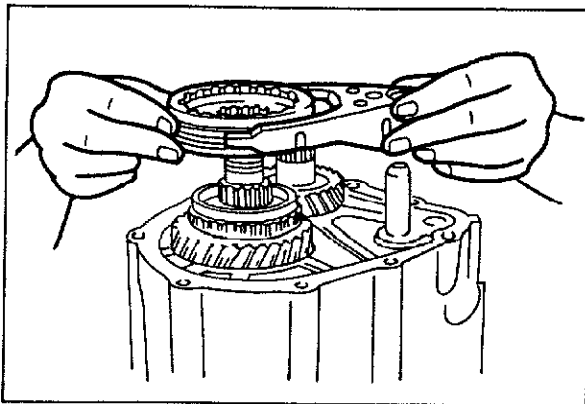

73G07A-023

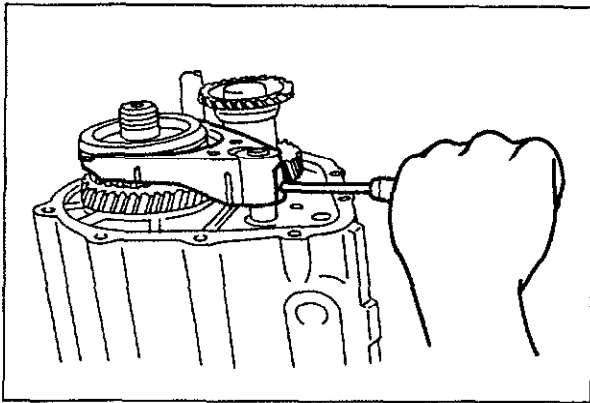

73G07A-024

8. Align the shift fork and shift rod spring pin holes, tap in the spring pin, and install the synchronizer ring and the reverse synchronizer gears.

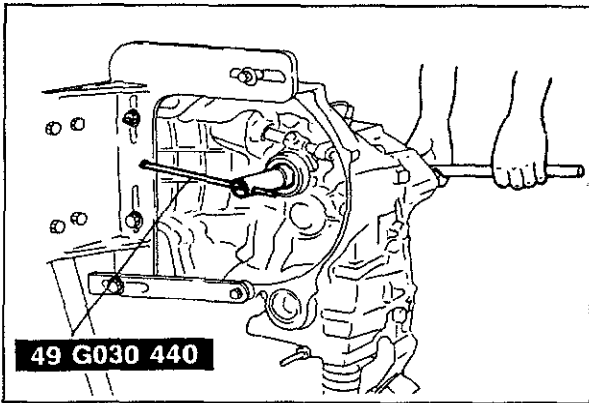

83U07A-093

9. Lock the shaft gear using the **SST**, then tighten the primary shaft gear and the secondary shaft gear lock nuts to the specified torque.
10. Remove the shaft holder, then stake the lock nut to the groove.

**Caution**  
Shift to 1st or 2nd gear.

**Tightening torque: 128—196 N·m**  
(13.0—20.0 m·kg, 94—145 ft·lb)

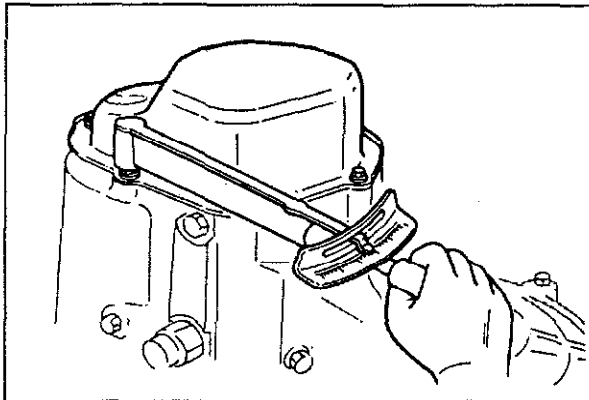

76U07A-290

11. Coat the surface of the transaxle case which faces the rear cover with sealant, then install the rear cover and tighten the bolts to the specified torque.

**Tightening torque:**  
8—11 N·m (0.8—1.1 m·kg, 69—95 in·lb)

**Caution**  
Before coating with sealant, clean the contact surfaces of the rear cover and the transaxle case.

12. Temporarily install the speedometer driven gear.

**Caution**  
Before tightening the driven gear into the transaxle, connect the transaxle to the engine and supply the necessary amount of transaxle oil.

13. Move the change rod to check the shifting operations, then remove the transaxle from the **transaxle hanger**.

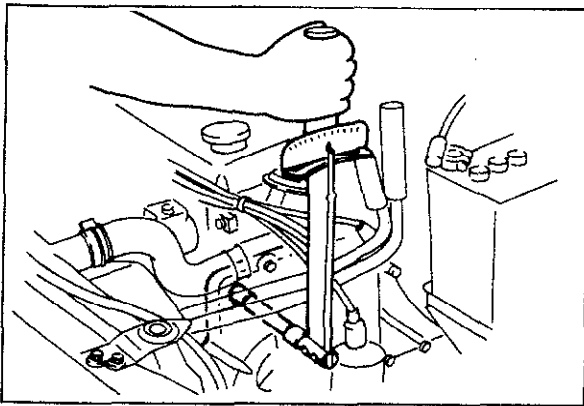

83U07A-094

## INSTALLATION

Install in the reverse order of removal and be careful of the following:

### Transaxle

Apply a thin coat molybdenum disulphide grease to the spine of the primary shaft gear. Tighten the transaxle mounting bolts to the specified torque.

#### Tightening torque:

##### Upper bolts

63—89 N·m (6.5—9.1 m·kg, 47—66 ft·lb)

##### Lower bolts

63—89 N·m (6.5—9.1 m·kg, 47—66 ft·lb)

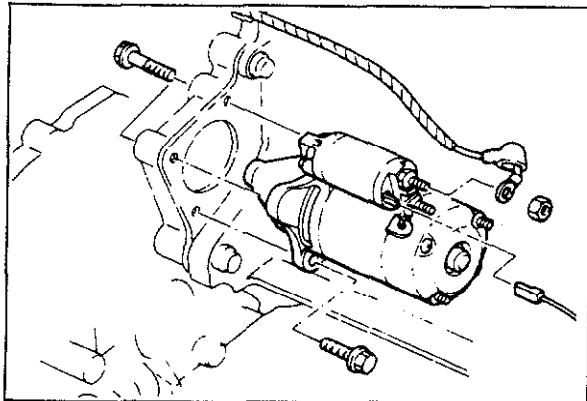

63U07A-140

### Starter

Tighten the starter to the specified torque.

#### Tightening torque:

31—46 N·m (3.2—4.7 m·kg, 23—34 ft·lb)

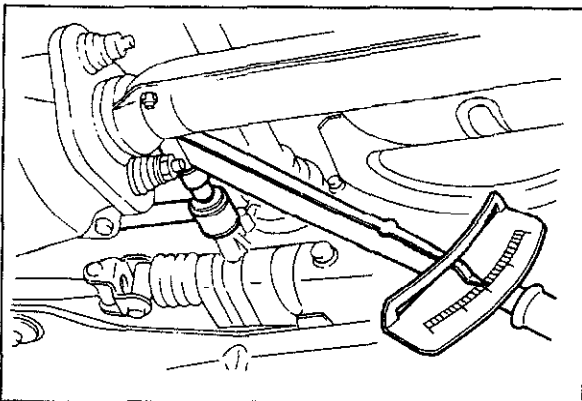

63U07A-141

### Extension Bar and Change Control Rod

Install the extension bar and the change control rod, and tighten them to the specified torque.

#### Tightening torque

##### Extension bar:

31—46 N·m (3.2—4.7 m·kg, 23—34 ft·lb)

##### Change control rod:

16—22 N·m (1.6—2.3 m·kg, 12—17 ft·lb)

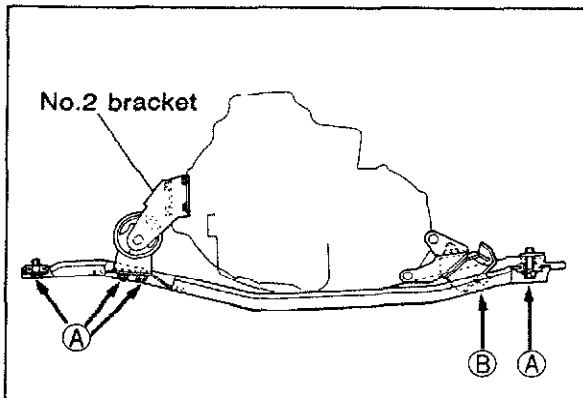

63U07A-142

### Crossmember

After tightening the engine mounting rubber No. 2 bracket to the transaxle, install the crossmember and tighten to the specified torque.

#### Tightening torque

##### No. 2 bracket:

37—52 N·m (3.8—5.3 m·kg, 27—38 ft·lb)

##### A:

64—89 N·m  
(6.5—9.1 m·kg, 47—66 ft·lb)

##### B:

28—46 N·m  
(2.9—4.7 m·kg, 20—34 ft·lb)

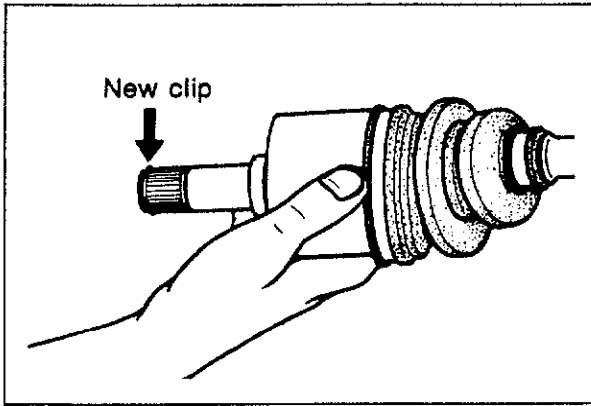

63U07A-143

### Clip

Replace the clip at the end of the driveshaft with a new one. Insert the clip with gap to the top of the groove.

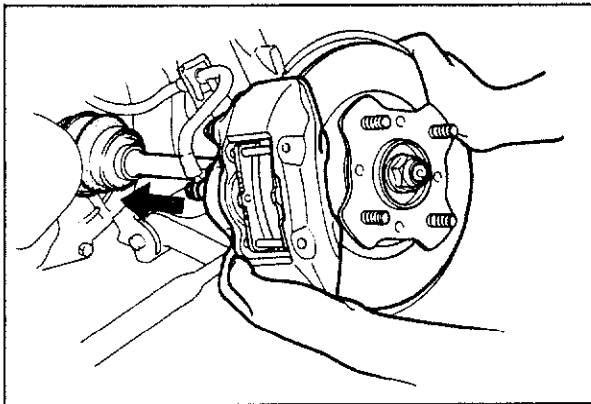

63U07A-114

### Driveshaft

Fit the driveshaft to the side gear, and push it into the transaxle by pushing in on the front hub.

### Caution

- a) When installing the driveshaft, be careful not to damage the oil seal.
- b) After installation, pull the front hub outward to confirm that the driveshaft is securely held by the clip.

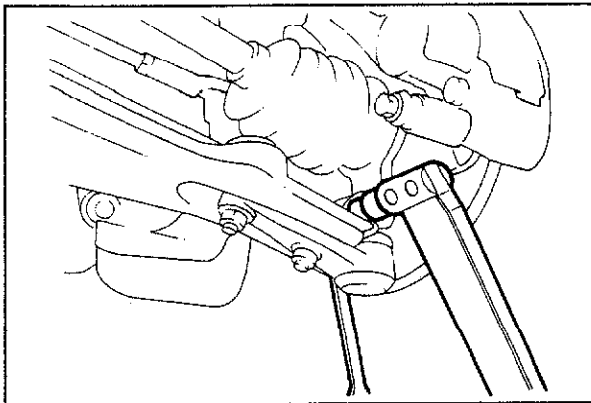

63U07A-145

### Ball Joint

Install the lower arm ball joint to the knuckle, and tighten the bolt.

### Tightening torque:

43—54 N·m (4.4—5.5 m·kg, 32—40 ft·lb)

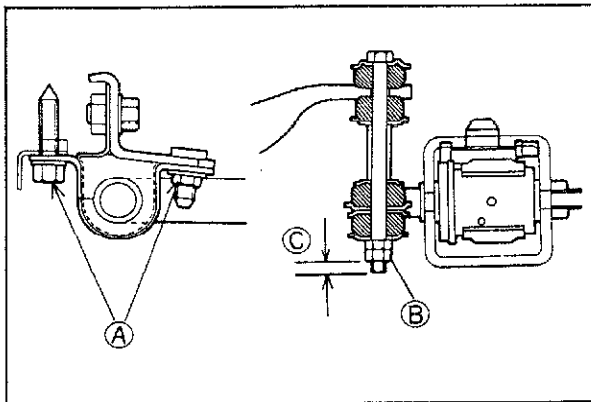

63U07A-146

### Stabilizer

Install and adjust the front stabilizer.

### Tightening torque

A: 31—44 N·m  
(3.2—4.5 m·kg, 23—33 ft·lb)

B: 12—81 N·m  
(1.2—1.8 m·kg, 9—13 ft·lb)

Dimension C: 10.8 mm (0.43 in)

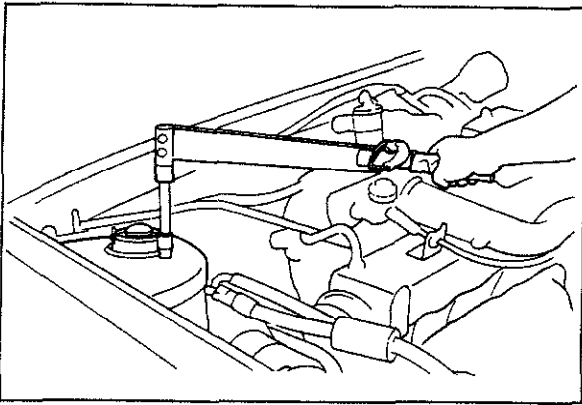

63U07A-147

### Mounting Block

Remove the engine support, and tighten the mounting block installation nuts to the specified torque.

### Tightening torque:

**23—29 N·m (2.3—3.0 m·kg, 17—22 ft·lb)**

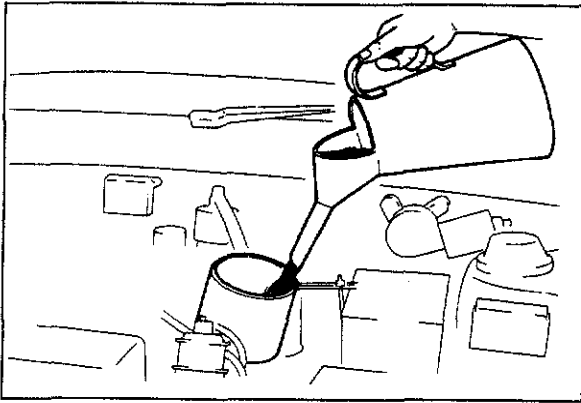

63U07A-148

### Transaxle Oil

1. Add the specified amount of the specified transaxle oil through the speedometer driven gear installation hole.
2. Road test the vehicle and check the transaxle for proper operation and check for oil leaks.

# TRANSAXLE CONTROL

## REMOVAL

After jacking up the vehicle and supporting it with safety stands, remove the parts in the numbered order shown in the figure.

63U07A-149

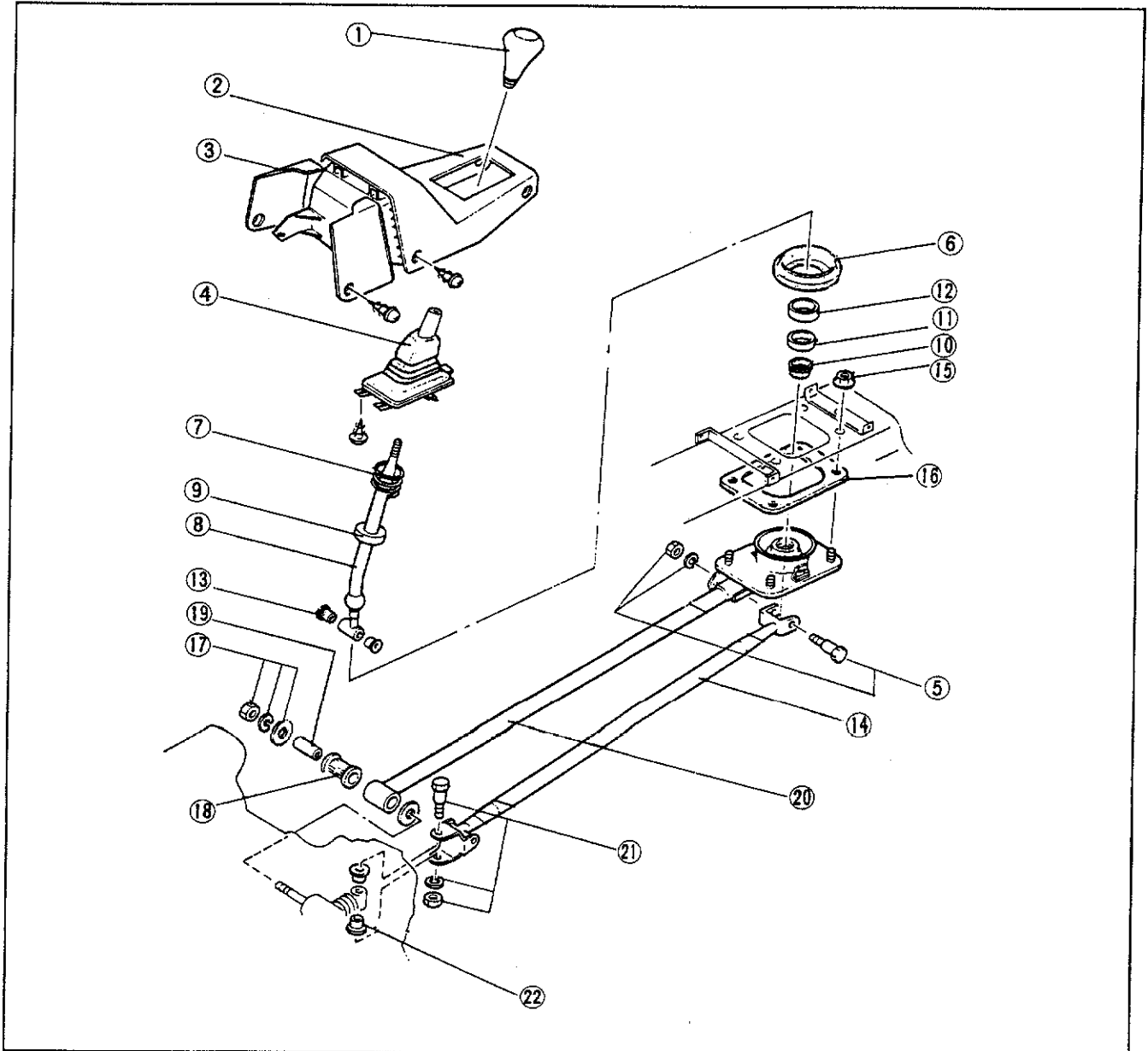

63U07A-150

- 1. Change lever knob
- 2. Center console
- 3. Side wall
- 4. Change boot
- 5. Bolt and nut
- 6. Mounting rubber
- 7. Spring

- 8. Change lever
- 9. Ball seat (upper)
- 10. Boot
- 11. Holder
- 12. Ball seat (lower)
- 13. Bushing
- 14. Change control rod

- 15. Self locking nut
- 16. Seal rubber
- 17. Nut and washer
- 18. Bushing
- 19. Spacer
- 20. Extension bar
- 21. Bolt and nut
- 22. Bushing

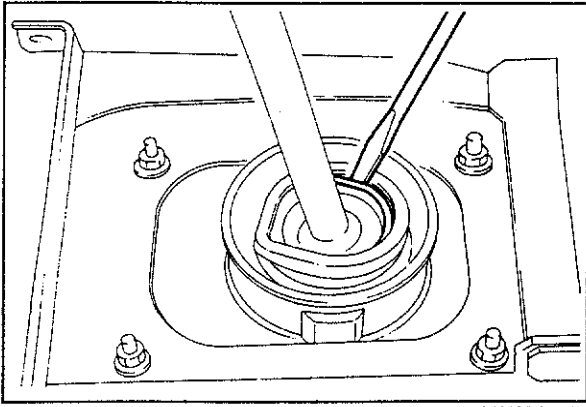

63U07A-151

## Spring

Remove the spring by prying on the hooked part of the spring with a screwdriver.

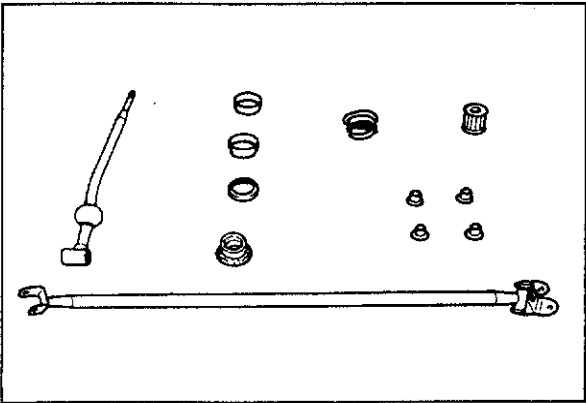

63U07A-152

## INSPECTION

Check the following, and replace if necessary:

1. Bent control rod.
2. Wear, damage, or malfunction of any joint.
3. Damaged change lever ball.
4. Weak spring.
5. Wear or damage of bushing.

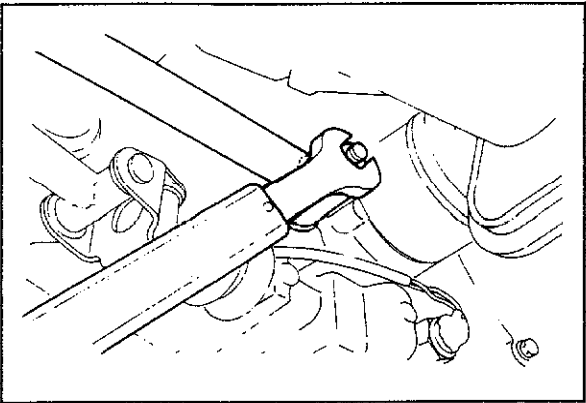

63U07A-153

## INSTALLATION

Install in the reverse order of removal and note the following:

### Extension Bar

First, install the extension bar to the floor, and then install it onto the transaxle.

### Tightening torque:

**31—46 N·m (3.2—4.7 m·kg, 23—34 ft·lb)**

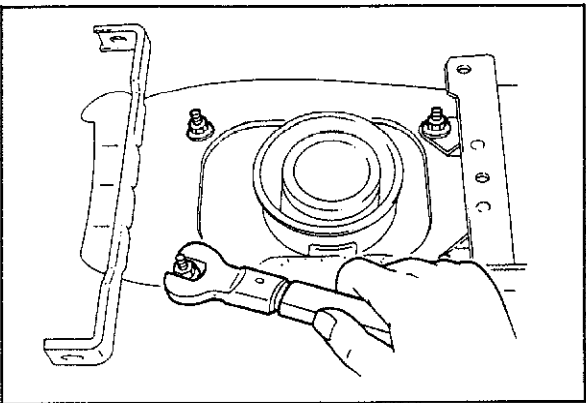

63U07A-154

### Self Locking Nut

Tighten the self locking nuts to the specified torque.

### Tightening torque:

**7—10 N·m (70—100 cm·kg, 61—87 in·lb)**



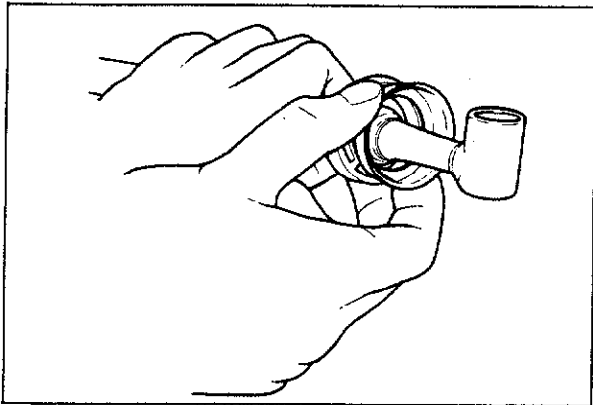

63U07A-155

## Change Lever Ball

Apply a coating of grease to the ball seat surface, and install the upper and lower ball seat, holder, and boot.

### Note

Also apply grease to all joints.

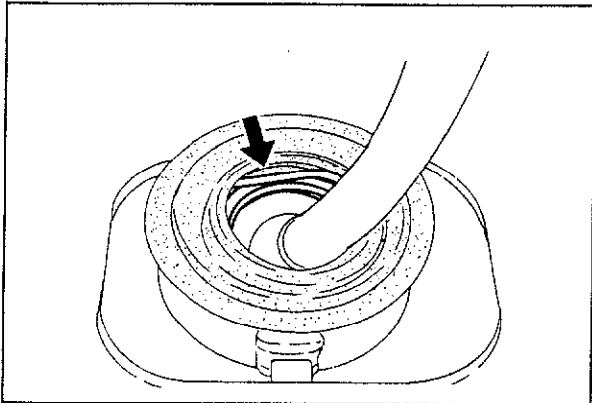

63U07A-156

## Spring

Make sure that the hooked part of spring is properly seated in the bracket groove, as shown in the figure.

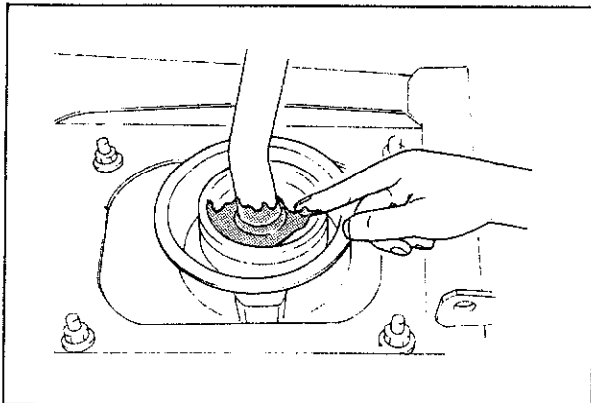

63U07A-157

## Bracket Cavity

Put grease in the bracket cavity.

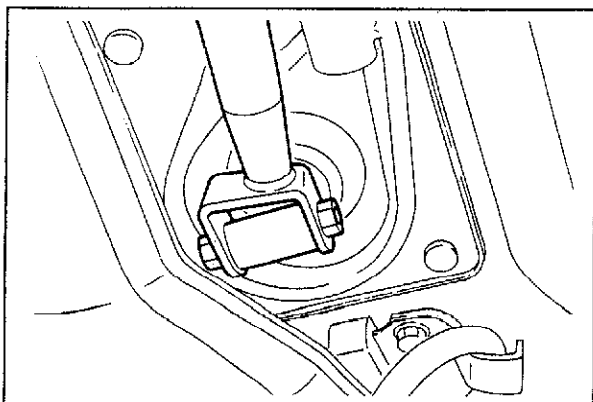

63U07A-158

## Change Control Rod

Install the change control rod so that its relationship with the change lever is as shown in the figure.

### Tightening torque:

16—22 N·m (1.6—2.3 m·kg, 12—17 ft·lb)

# MANUAL TRANSAXLE 4WD

<b>OUTLINE</b> .....	7C— 2
STRUCTURAL VIEW .....	7C— 2
CROSS-SECTIONAL VIEW .....	7C— 3
SPECIFICATIONS .....	7C— 4
<b>TROUBLESHOOTING GUIDE</b> .....	7C— 5
<b>ON-VEHICLE MAINTENANCE</b> .....	7C— 6
<b>REMOVAL</b> .....	7C—11
<b>DISASSEMBLY</b> .....	7C—15
STEP1 .....	7C—15
STEP2 .....	7C—22
STEP3 .....	7C—25
STEP4 .....	7C—30
STEP5 .....	7C—35
<b>INSPECTION</b> .....	7C—38
<b>ASSEMBLY</b> .....	7C—45
STEP1 .....	7C—45
STEP2 .....	7C—49
STEP3 .....	7C—58
STEP4 .....	7C—64
STEP5 .....	7C—74
<b>INSTALLATION</b> .....	7C—81
<b>TRANSAXLE CONTROL</b> .....	7C—85

## OUTLINE

### STRUCTURAL VIEW

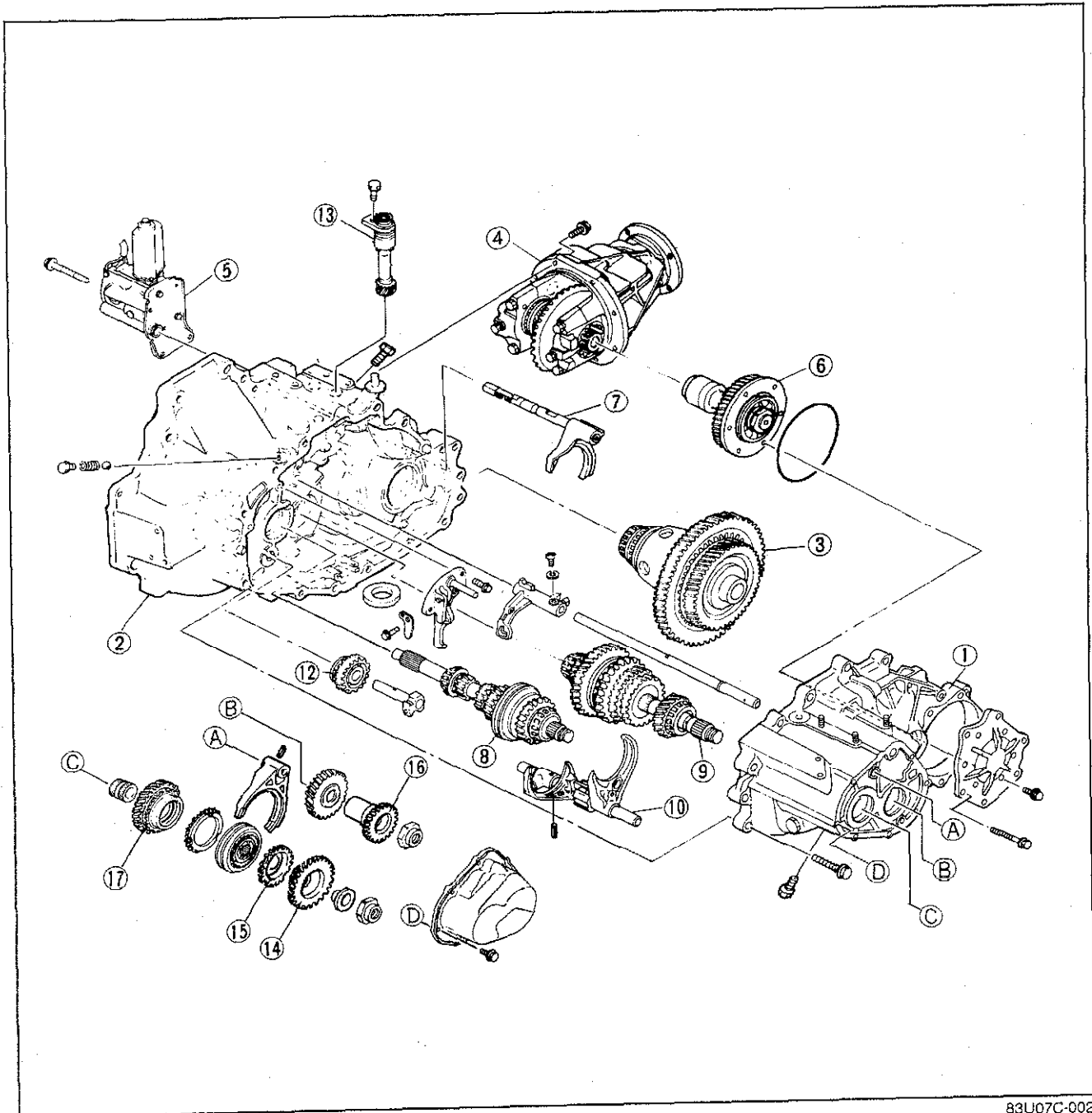

83U07C-002

- |   |   |
|---|---|
| 1. Transaxle case                               | 9. Secondary shaft gear assembly        |
| 2. Clutch housing                               | 10. Shift fork and shift rod assembly   |
| 3. Center differential                          | 11. 5th gear                            |
| 4. Transfer carrier                             | 12. Reverse idle gear                   |
| 5. Center differential lock assembly            | 13. Speedometer driven gear             |
| 6. Idle gear                                    | 14. Primary reverse synchronizer gear   |
| 7. Center differential lock shift fork assembly | 15. Synchronizer ring                   |
| 8. Primary shaft gear assembly                  | 16. Secondary reverse synchronizer gear |
|   | 17. 5th gear                            |

CROSS-SECTIONAL VIEW

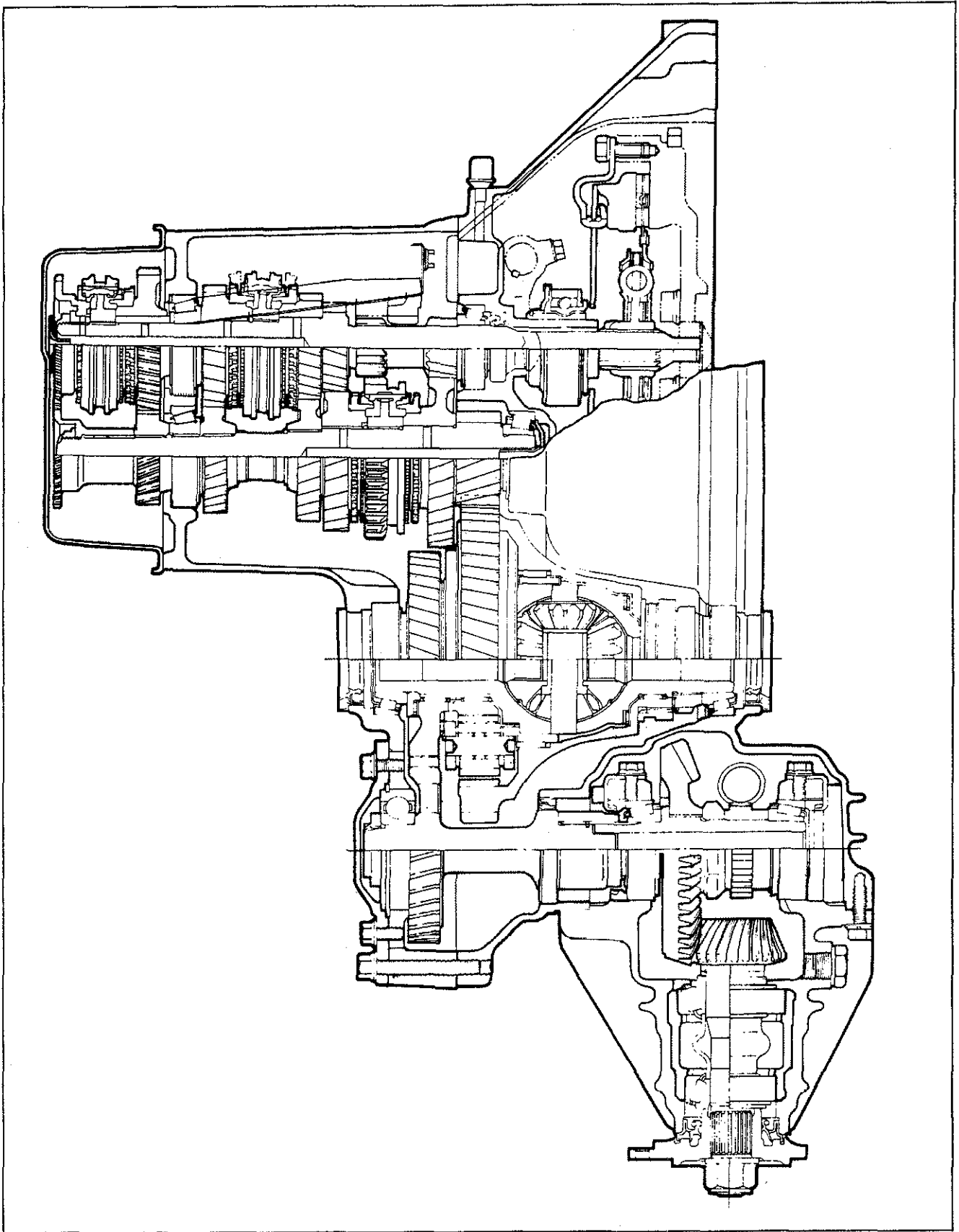

63G07C-003

## SPECIFICATIONS

Item		Engine model	B6 DOHC
Transaxle control			Floor shift
Synchromesh system			Forward ... Synchromesh, Reverse ... Selective sliding and synchromesh
Gear ratio	First		3.307
	Second		1.833
	Third		1.233
	Fourth		0.970
	Fifth		0.795
	Reverse		3.166
Front final gear ratio			4.105
Speedometer gear ratio			1.045
Oil	Transaxle	Type	ATF: DEXRON-II API: GL-4 or GL-5 SAE 80W-90 or SAE 90 (Above -18°C (0°F))
		Capacity	3.6 liters (3.8 US qt, 3.2 Imp qt)
	Transfer carrier	Type	API: GL-5 Above 0°F: SAE 90 Below 0°F: SAE 80W
		Capacity	0.5 liter (0.53 US qt, 0.44 Imp qt)

83U07C-003

## TROUBLESHOOTING GUIDE

Problem	Probable Cause	Remedy
<b>Shift lever won't shift smoothly, or is hard to shift</b>	Seized shift lever ball Seized shift control rod joint Bent shift control rod	Replace Replace Replace
<b>Too much play in shift lever</b>	Worn shift control rod bushing Weak shift level ball spring Worn shift lever ball bushing	Replace Replace Replace
<b>Difficult to shift</b>	Bent shift control rod No grease in transaxle control Insufficient oil Deterioration of oil quality  Wear or play of shift fork or shift rod Worn synchronizer ring Worn synchronizer cone of gear Bad contact of synchronizer ring and cone of gear Excessive longitudinal play of gears Worn bearing Worn synchronizer key spring Excessive primary shaft gear bearing preload Improperly adjusted change guide plate	Replace Lubricate with grease Add oil Replace with oil of specified quality Replace Replace Replace Replace Replace Adjust or replace Replace Adjust Adjust
<b>Won't stay in gear</b>	Bent shift control rod Worn shift control rod bushing Weak shift lever ball spring Improperly installed extension bar Worn shift fork Worn clutch hub Worn clutch hub sleeve Worn secondary shaft gear Worn sliding surface of gear Worn steel ball detent of control end Weak spring pressing against steel ball Excessive gear backlash Worn bearing Improperly installed engine mount	Replace Replace Replace Tighten Replace Replace Replace Replace Replace Replace Replace Replace Replace Tighten
<b>Abnormal noise</b>	Insufficient oil Deterioration of oil quality  Worn bearing Worn secondary shaft gear Worn sliding surface of gear Excessive gear backlash Damaged gear teeth Foreign material in gears Damaged differential gear, or excessive backlash	Add oil Replace with oil of specified quality Adjust or replace Replace Replace Replace Replace Replace Replace Repair or replace

63G07C-005

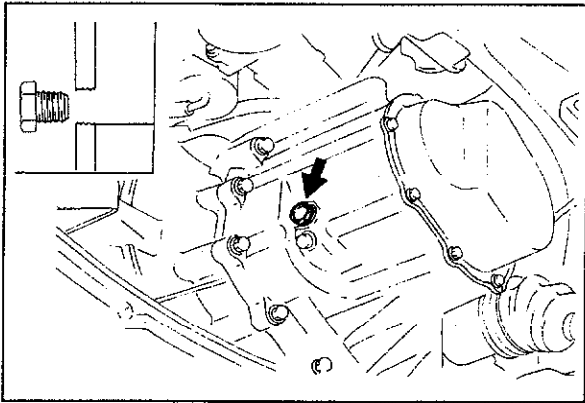

63G07C-006

## ON-VEHICLE MAINTENANCE

### TRANSAXLE AND TRANSFER CARRIER OIL

Remove the oil-supply port plug. Check if the oil level is near the opening.

If the level is low, add the specified oil.

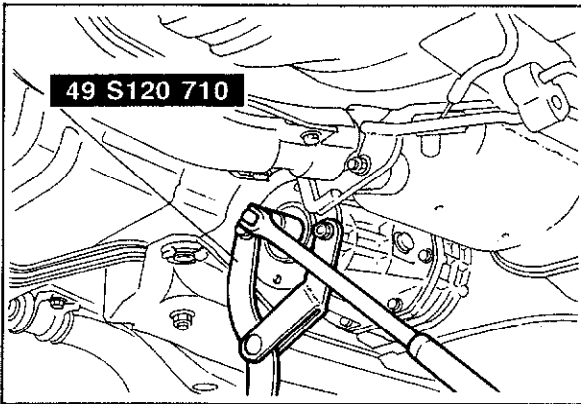

83U07C-042

### OIL SEAL (Transfer Carrier) Replacement

1. Remove the drain plug and oil.
2. Remove the propeller shaft.
3. Before loosening the lock nut, measure the rotation starting torque of the drive pinion.

#### Note

**Make a notation of this torque, at the time of installation, tighten the lock nut to this value.**

4. Remove the lock nut with the **SST**.
5. Remove the companion flange with the **SST**.

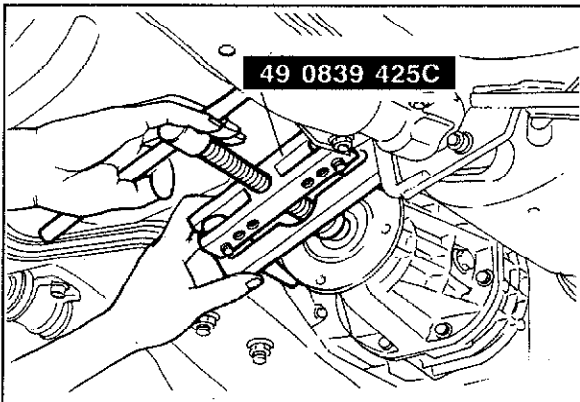

83U07C-043

6. Remove the oil seal.

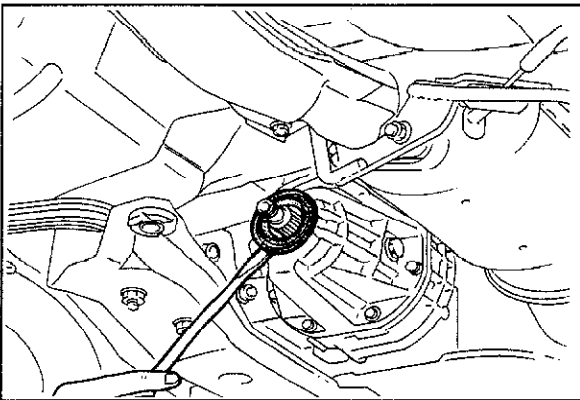

63G07C-009

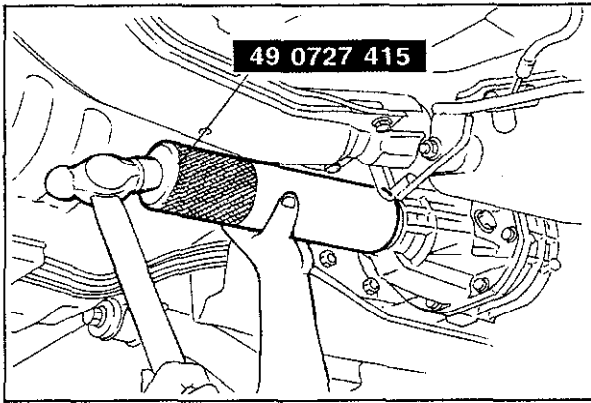

83U07C-044

7. Install the new oil seal with the **SST**.

**Note**

**Coat the seal with differential oil.**

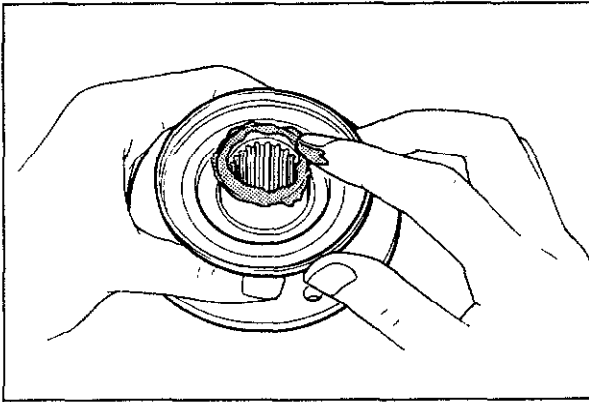

8. Coat companion flange seal surface with differential oil and install the washer and companion flange.

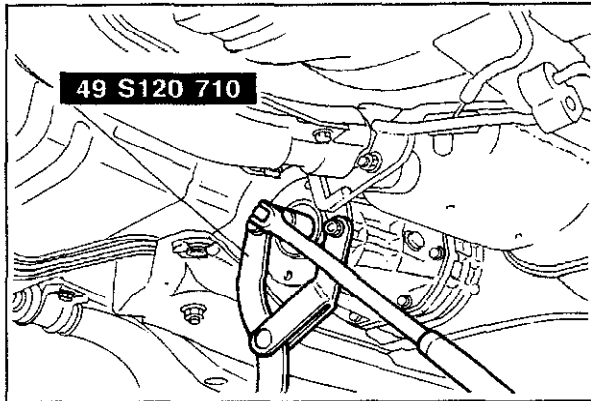

83U07C-046

9. Tighten the bolt with the **SST**.

**Note**

**Check the drive pinion preload.**

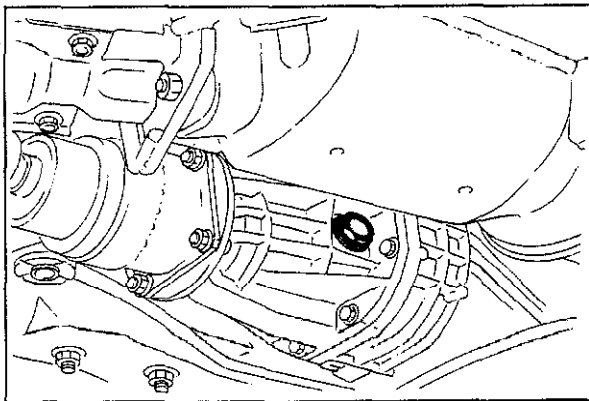

83U07C-047

10. Install the drain plug and add the specified oil.

**Tightening torque:**

**39—59 N·m (4—6 m·kg, 29—43 ft·lb)**



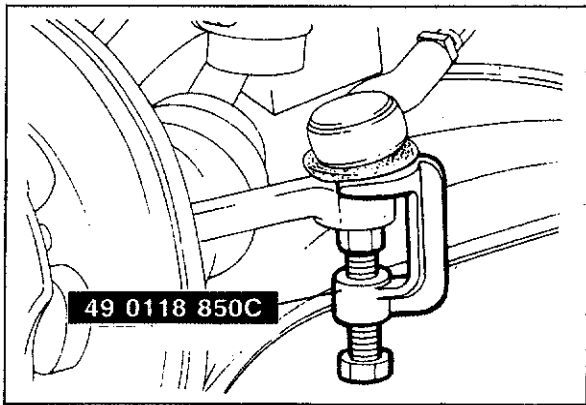

83U07C-048

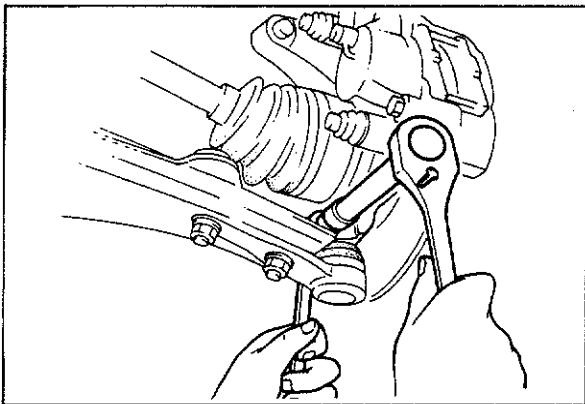

83U07C-049

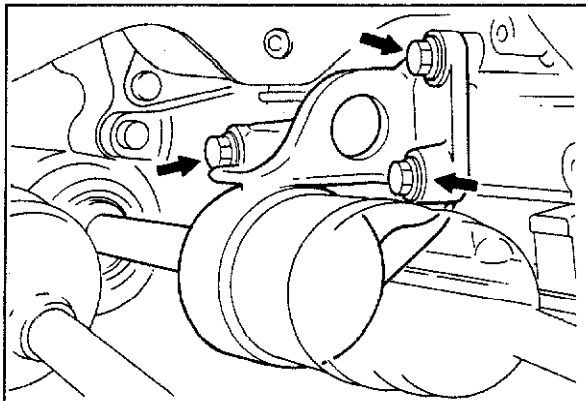

83U07C-050

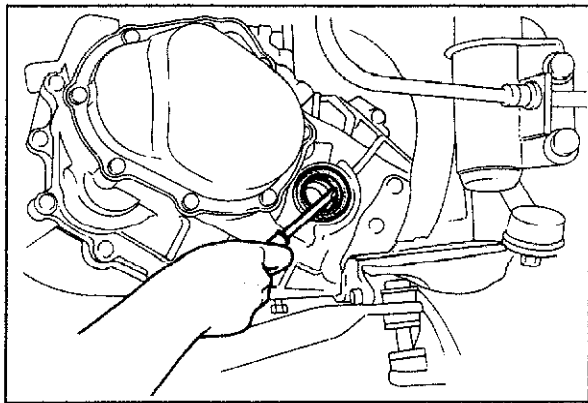

63G07C-018

## OIL SEAL (Transaxle)

1. Remove the tie-rod end from the knuckle with the SST.

2. Remove the clinch bolt and pull the lower arm downward. Separate the knuckle from the lower arm ball-joint.

### Note

**Be careful not to damage the ball-joint dust boot.**

3. Remove the drain plug and oil.

4. Remove the joint shaft bolts.

5. Remove the wheel hub and shaft.

6. Remove the oil seal.

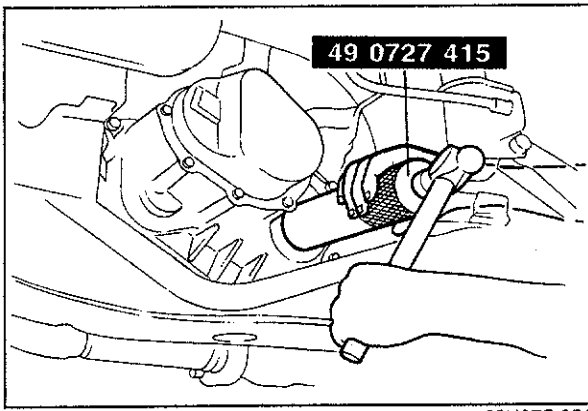

83U07C-051

7. Install the new oil seal with the **SST**.

**Note**

**Coat transaxle oil on oil seal.**

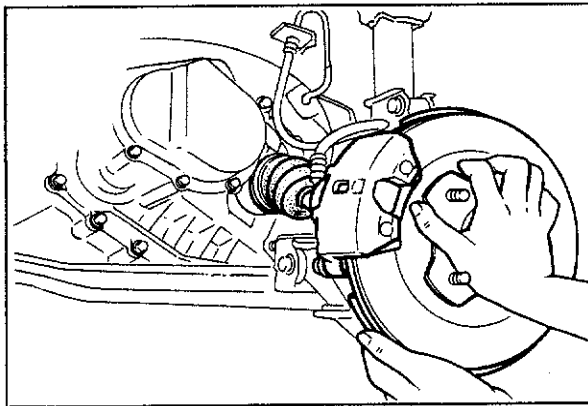

83U07C-052

8. Fit a new clip on driveshaft.

9. Install the driveshaft to transaxle and transfer carrier.

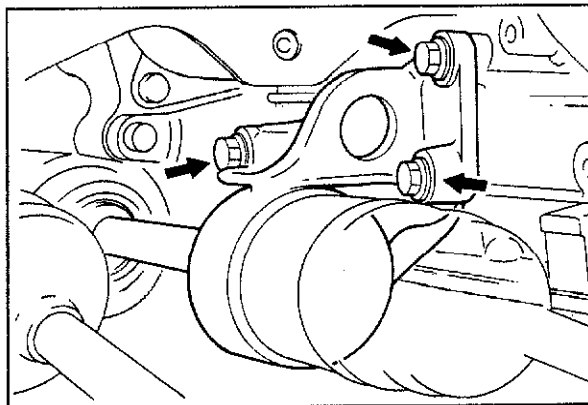

83U07C-053

10. Install the joint shaft.

**Tightening torque:**

**42—62 N·m (4.3—6.3 m·kg, 31—46 ft·lb)**

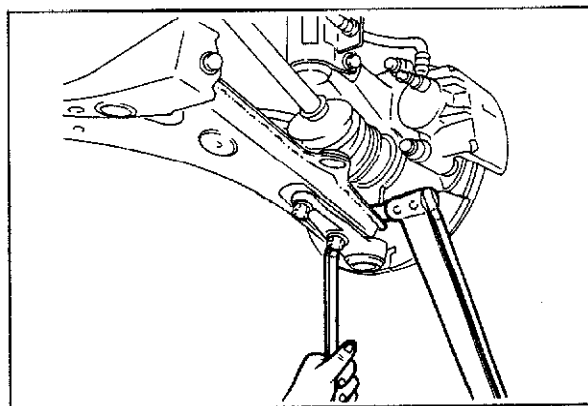

83U07C-054

11. Install the lower arm ball-joint to the knuckle and tighten.

**Tightening torque:**

**43—54 N·m (4.4—5.5 m·kg, 32—40 ft·lb)**

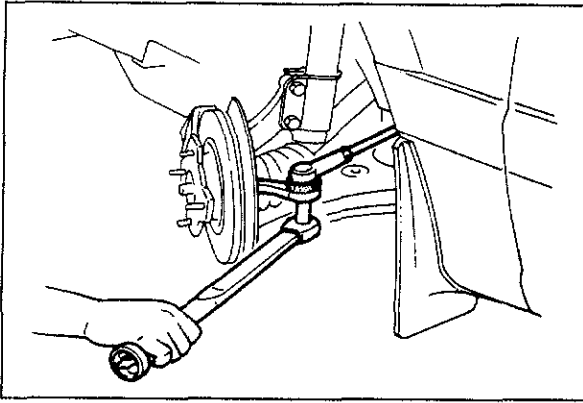

83U07C-055

12. Install the tie-rod end to the knuckle and tighten it.

**Tightening torque:**  
29—44 N·m (3.0—4.5 m·kg, 22—33 ft·lb)

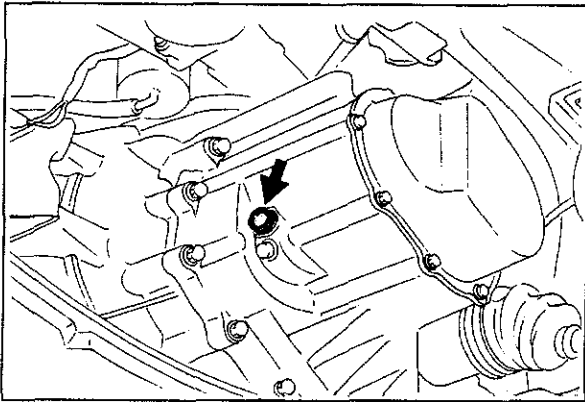

83U07C-056

13. Install the drain plug and add the specified oil from oil-supply port plug.

**Tightening torque: 39—54 N·m**  
(4.0—5.5 m·kg, 29—40 ft·lb)

## REMOVAL

Remove in the sequence shown in the figure.

63G07C-301

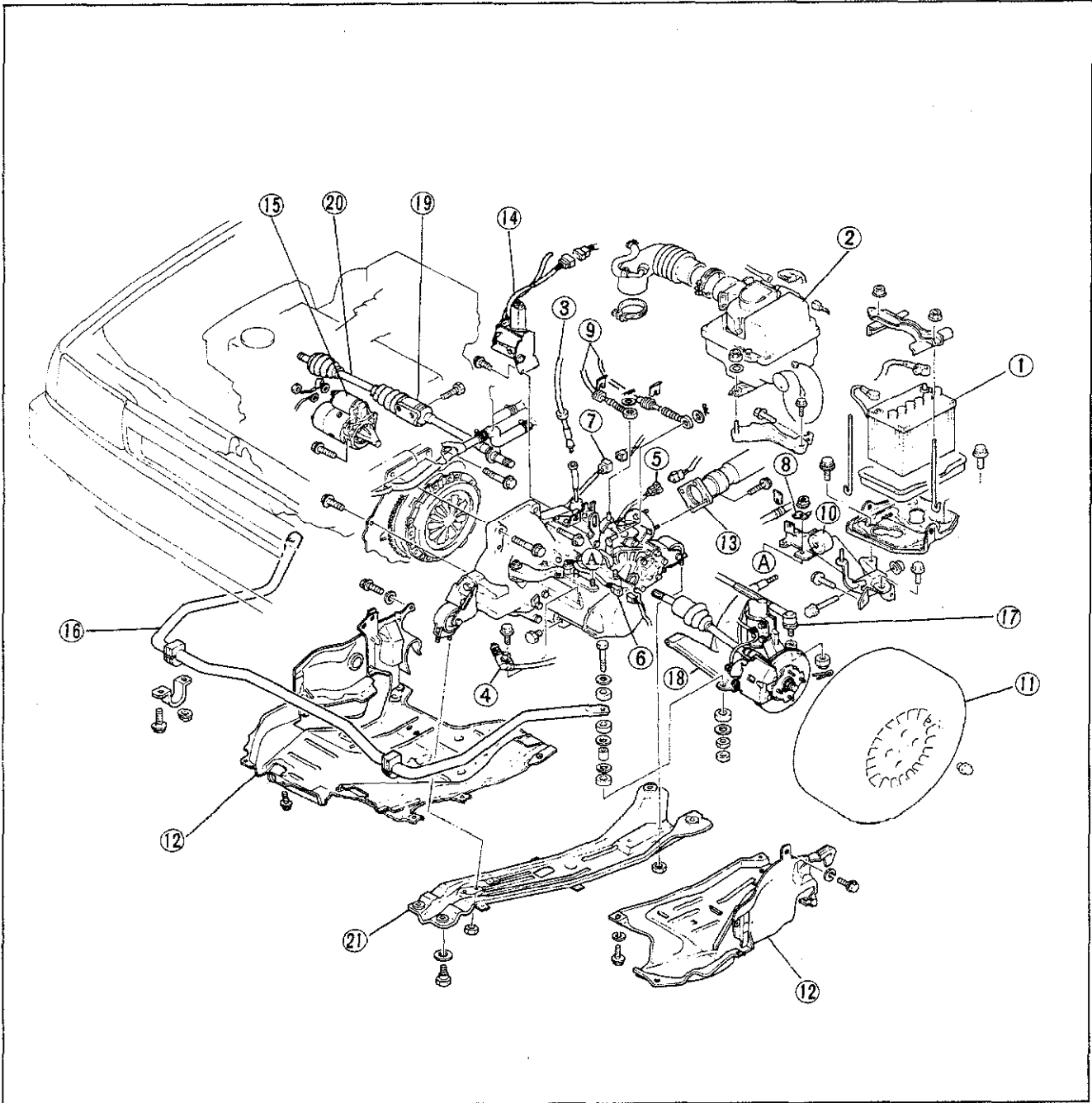

63G07C-026

- |   |                                       |                     |
|---|---------------------------------------|---------------------|
| 1. Battery                                | 8. Body ground                        | 15. Starter         |
| 2. Air cleaner                            | 9. Control cable                      | 16. Stabilizer      |
| 3. Speedometer cable                      | 10. Mount bracket No. 4               | 17. Tie-rod end     |
| 4. Clutch release cylinder                | 11. Tire and wheel                    | 18. Lower arm       |
| 5. Neutral switch                         | 12. Side cover and undercover         | 19. Joint shaft     |
| 6. Backup lamp switch                     | 13. Propeller shaft                   | 20. Driveshaft      |
| 7. Center differential lock sensor switch | 14. Center differential lock assembly | 21. Mounting member |

# 7C REMOVAL

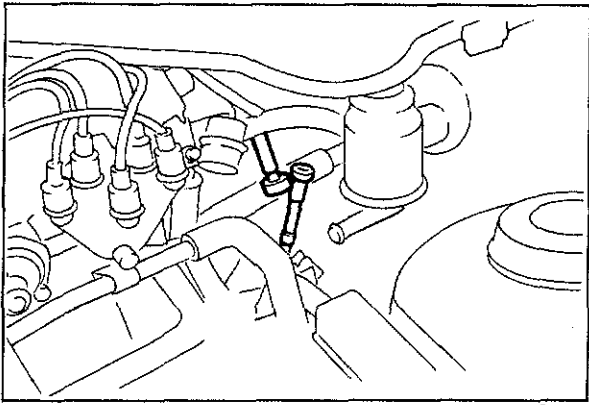

63G07C-027

1. Disconnect the speedometer cable in the center.

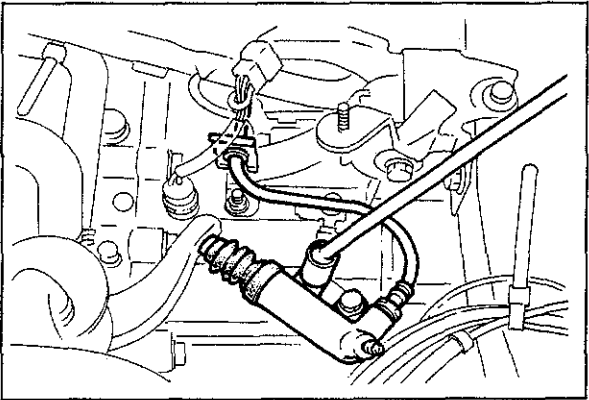

83U07C-057

2. Remove the bolt and clip, and remove the clutch release cylinder.

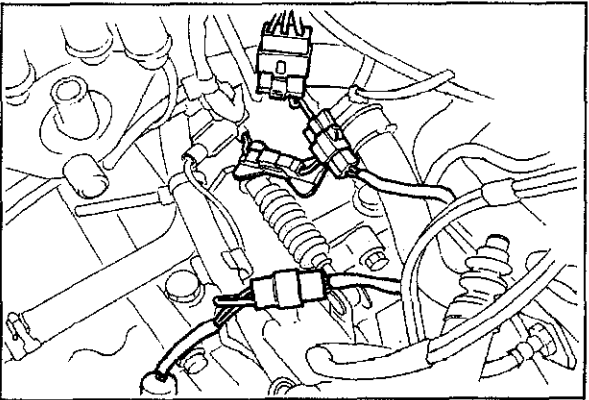

83U07C-058

3. Disconnect the neutral switch, backup lamp switch, differential lock sensor switch, and differential lock motor connector.

4. Remove the body ground.

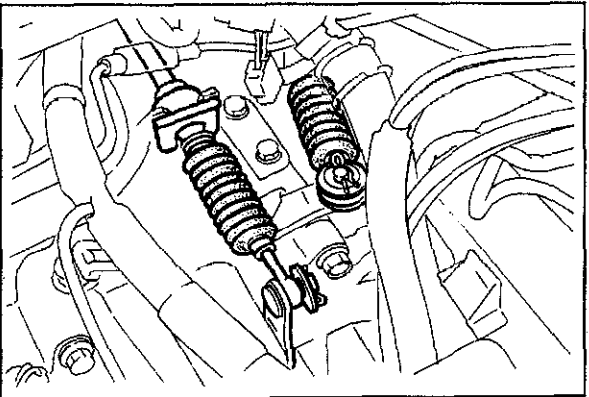

63G07C-030

5. Remove the pin and cable.

6. Remove the clip and cable.

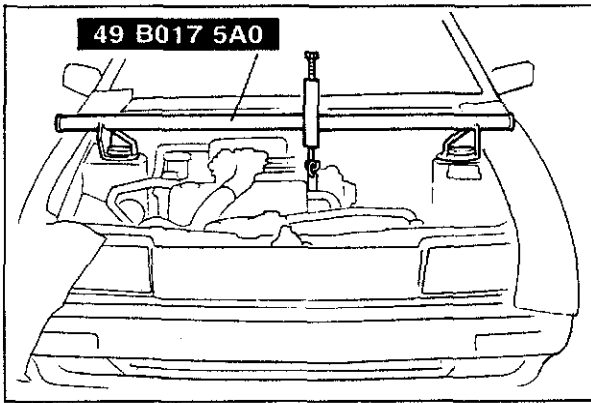

83U07C-059

7. Mount the **SST** to the engine hanger.

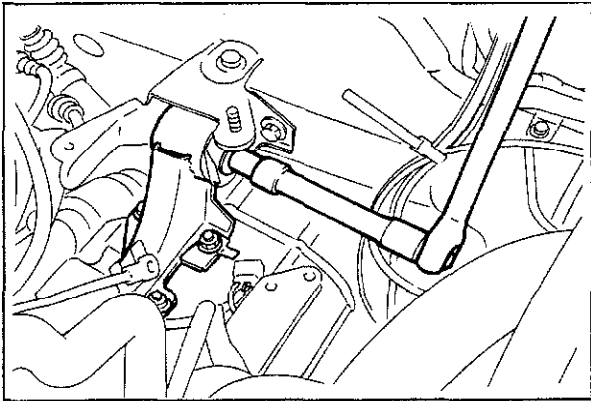

63G07C-032

8. Remove mount bracket No. 4.  
9. Remove the wheels.

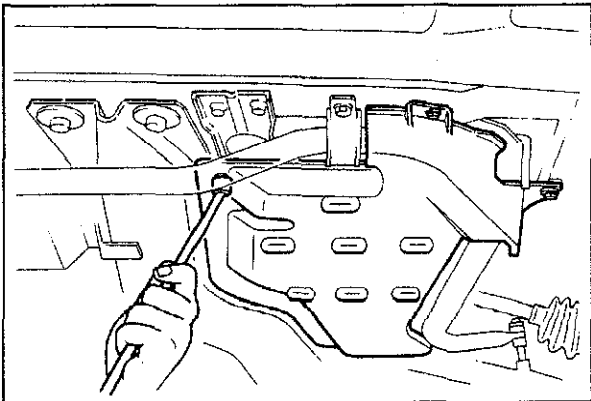

63G07C-033

10. Remove the side cover and undercover.

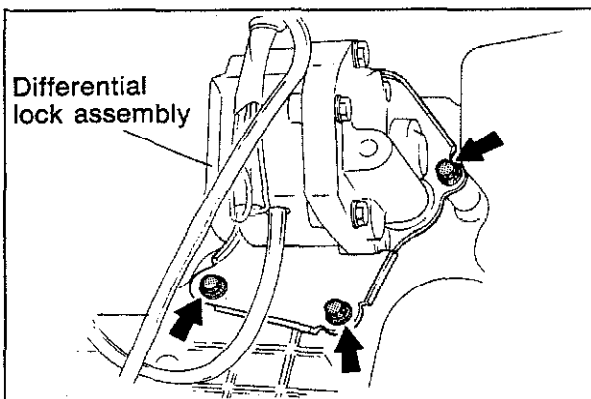

83U07C-060

11. Remove the oil filter, differential lock assembly, starter and stabilizer.

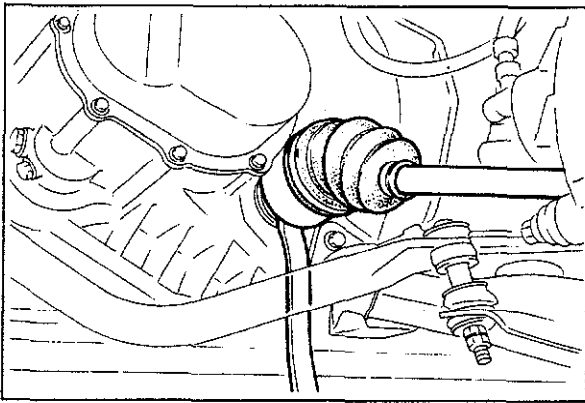

83U07C-061

12. Remove the tie-rod end and lower arm.
13. Remove the driveshaft.

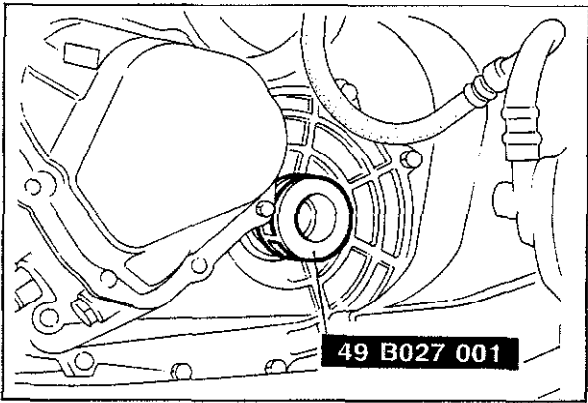

83U07C-062

14. Insert the **SST** to hold the side gear.

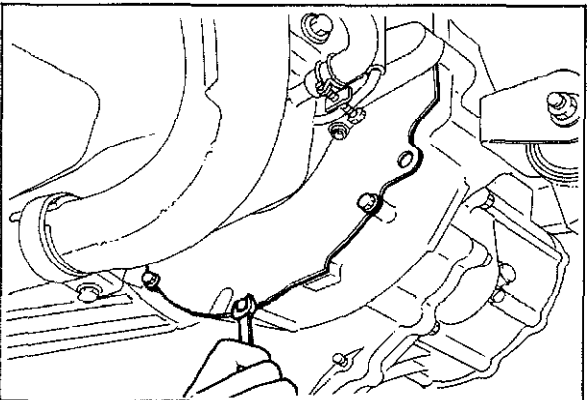

63G07C-037

15. Remove the end plate bolts.

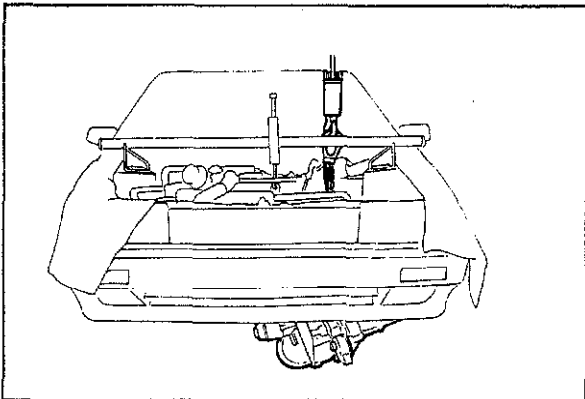

63G07C-038

16. Use an engine hoist and remove the transaxle and transfer carrier.

## DISASSEMBLY

## DISASSEMBLY-STEP 1

Disassemble in the sequence shown in the figure.

83U07C-042

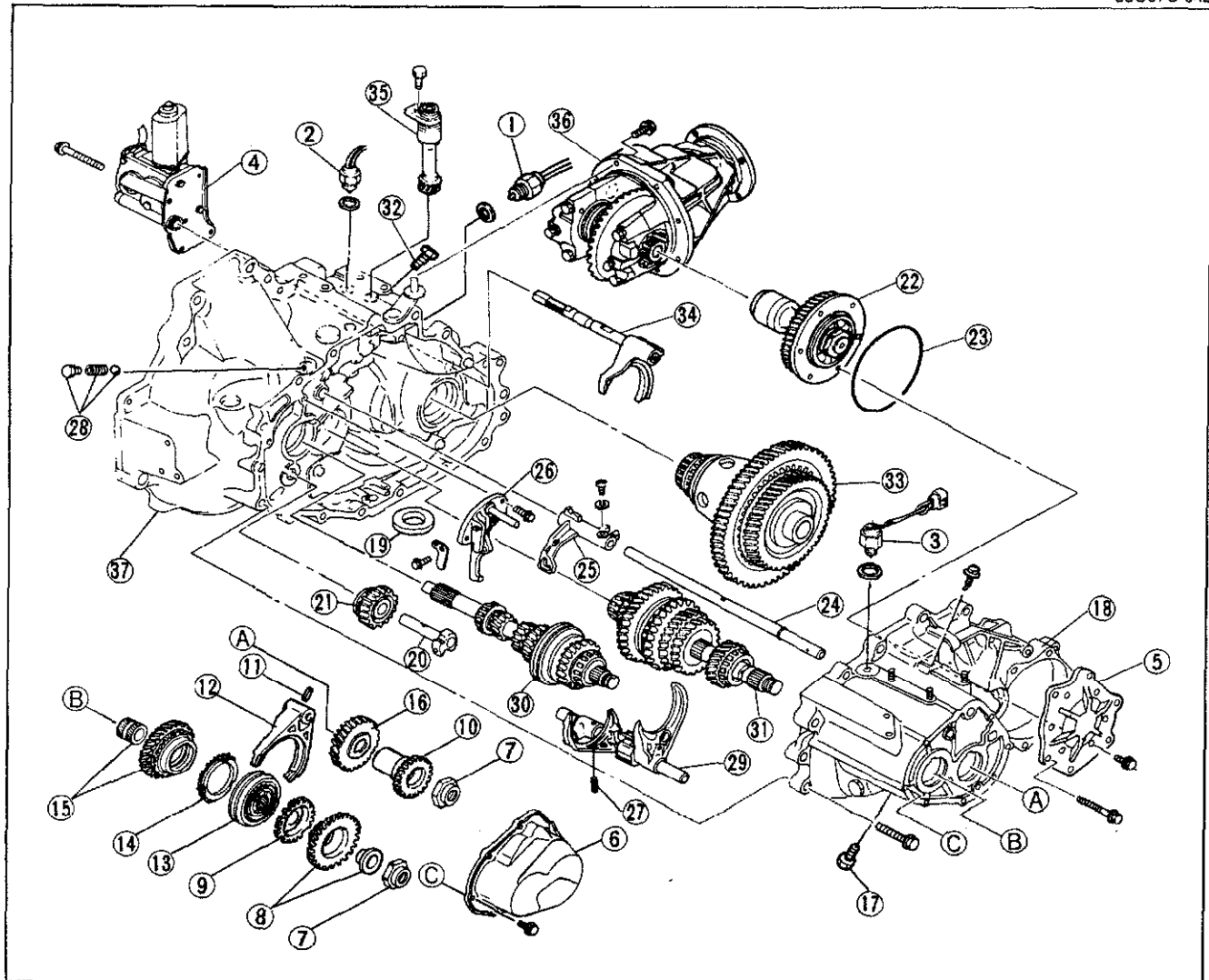

83U07C-004

- |  |                              |  |
|--|------------------------------|--|
| 1. Neutral switch                                    | 12. Shift fork               | 27. Spring pin                                   |
| 2. Center differential lock switch                   | 13. Clutch hub assembly      | 28. Ball, spring and bolt                        |
| 3. Backup lamp switch                                | 14. Synchronizer ring        | 29. Shift fork and shift rod assembly            |
| 4. Center differential lock assembly                 | 15. 5th gear and gear sleeve | 30. Primary shaft gear assembly                  |
| 5. Side cover  | 16. Secondary 5th gear       | 31. Secondary shaft gear assembly                |
| 6. Rear cover  | 17. Bolt                     | 32. Bolt   |
| 7. Lock nut (s)                                      | 18. Transaxle case           | 33. Center differential assembly                 |
| 8. Primary reverse synchronizer gear and gear sleeve | 19. Magnet                   | 34. Center differential lock shift fork assembly |
| 9. Synchronizer ring                                 | 20. Reverse idle shaft       | 35. Speedometer driven gear                      |
| 10. Secondary reverse synchronizer gear              | 21. Reverse idle gear        | 36. Transfer carrier assembly                    |
| 11. Spring pin                                       | 22. Idle gear                | 37. Clutch housing                               |
|  | 23. "O" ring                 |  |
|  | 24. Shift rod                |  |
|  | 25. Shift gear               |  |
|  | 26. Reverse lever support    |  |



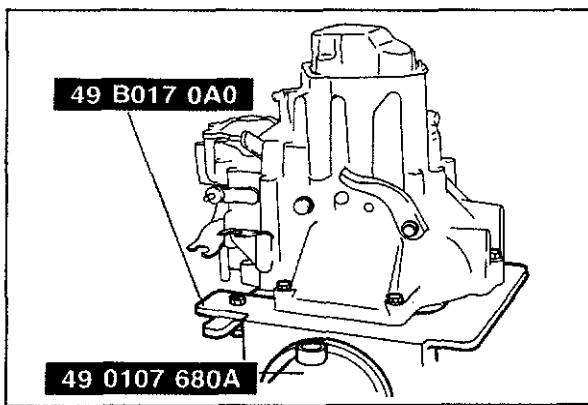

83U07C-063

## Transaxle

Position the **SST** and mount the transaxle on the **SST**.

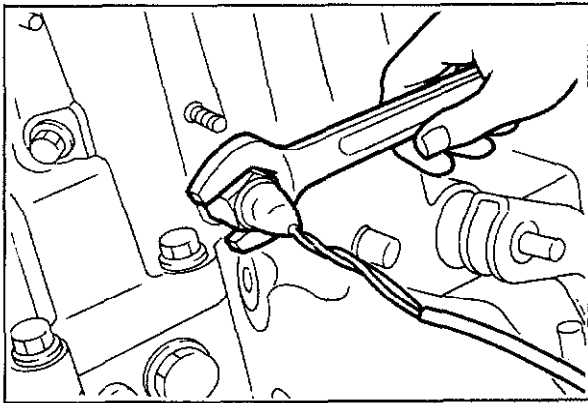

63G07C-041

## Switch

Remove the neutral switch, center differential lock sensor switch and backup lamp switch.

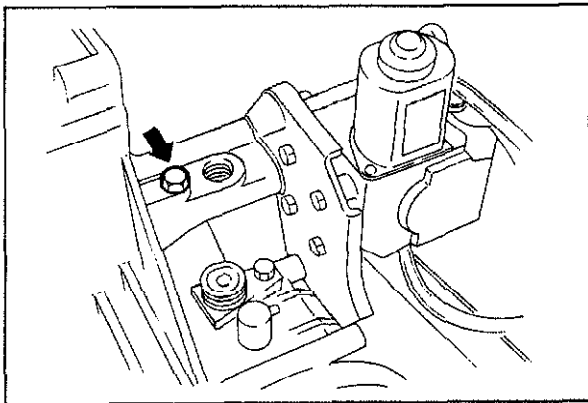

63G07C-042

## Center Differential Lock Assembly

1. Remove the bolt.

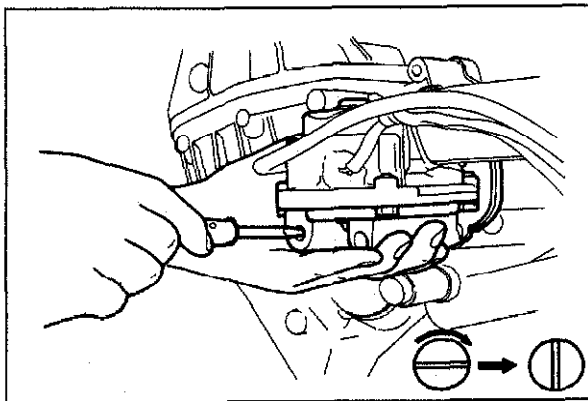

63G07C-043

2. Turn the differential lock shift rod 90° clockwise with flat-tipped screwdriver.

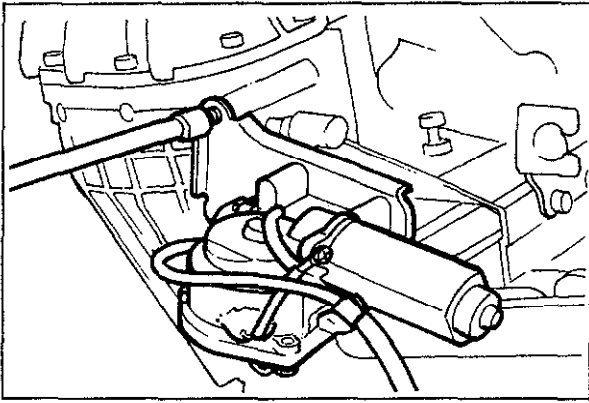

63G07C-044

3. Remove the differential lock assembly.

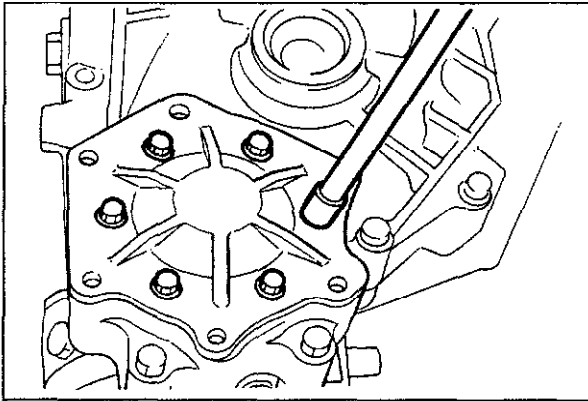

63G07C-045

### Cover

1. Remove the side cover.

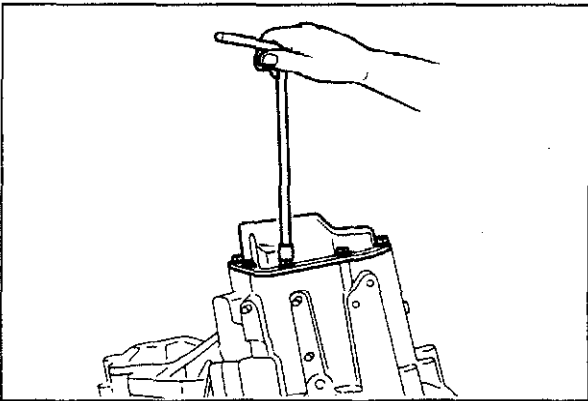

63G07C-046

2. Remove the rear cover.

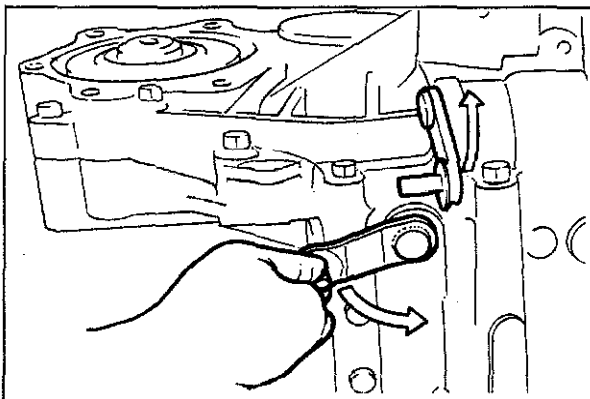

63G07C-047

### 5th Gear

1. Shift the lever into 1st gear.

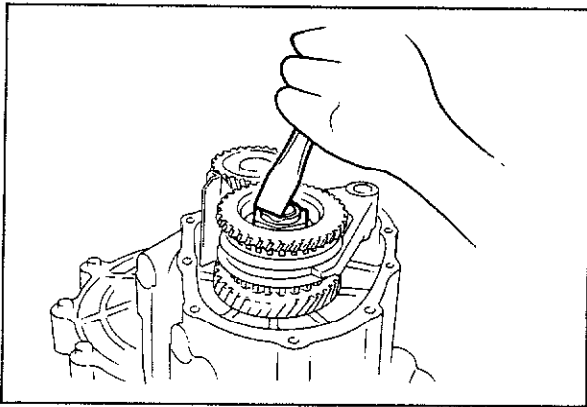

83U07C-005

2. Uncrimp the tab of the lock nuts.

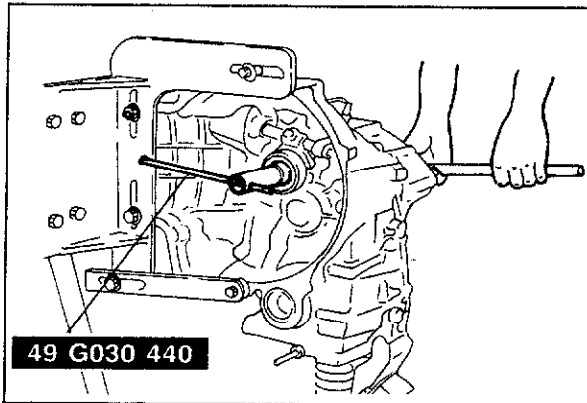

83U07C-006

3. Lock the primary shaft with the **SST**, and remove the lock nuts.

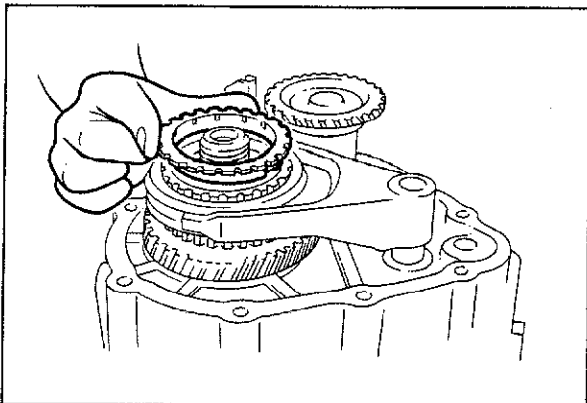

83U07C-007

4. Drive the spring pin out and remove the primary reverse synchronizer gear, gear sleeve and synchronizer ring.

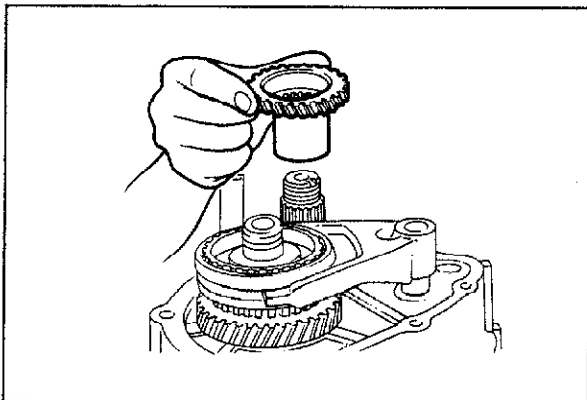

83U07C-008

5. Remove the secondary reverse synchronizer gear.  
6. Remove the shift fork and clutch hub assembly.  
7. Remove the synchronizer ring, the 5th gear and gear sleeve.

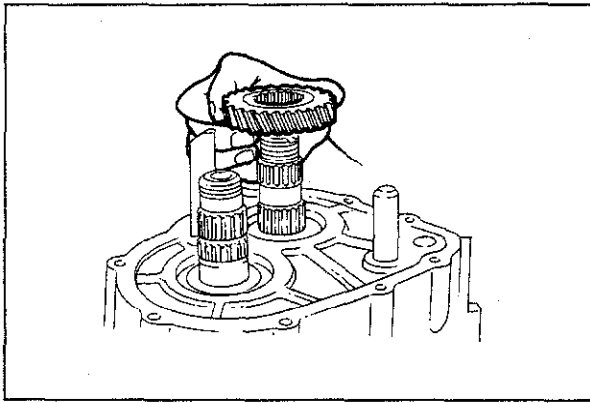

83U07C-009

7. Remove the secondary 5th gear.

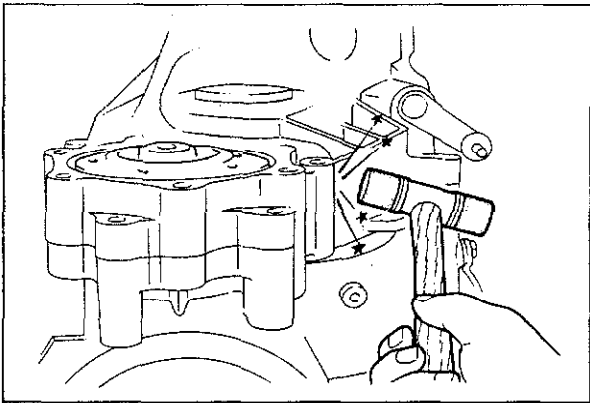

63G07C-053

### Transaxle Case

1. Remove the idle gear shaft mount bolt and interlock sleeve mount bolt.
2. Disconnect the idle gear from the transaxle case by tapping lightly with a plastic hammer.
3. Remove the transaxle case.
4. Remove the magnet.

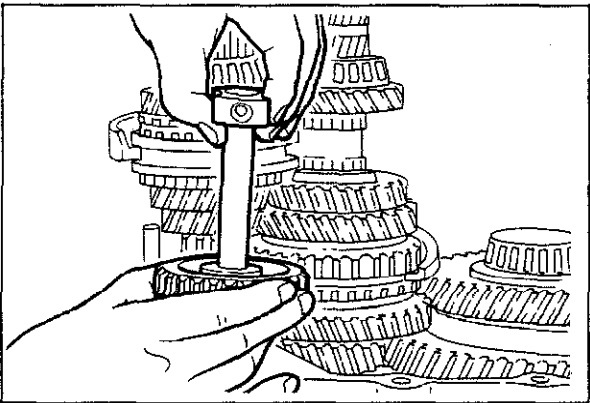

63G07C-054

### Reverse Idle Gear

Remove the reverse idle shaft and reverse idle gear.

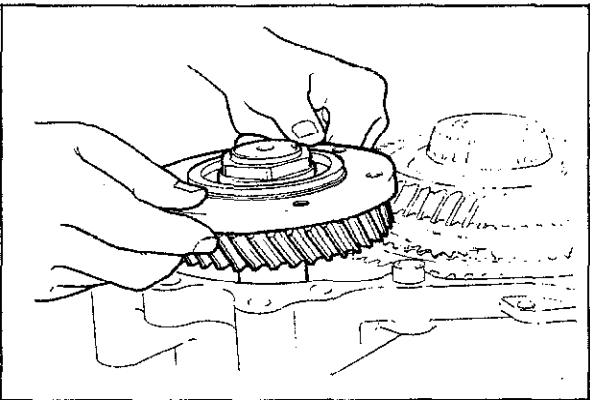

63G07C-055

### Idle Gear

Remove the idle gear and "O" ring.

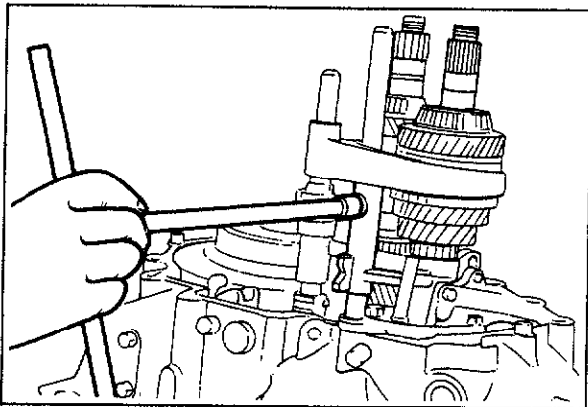

63G07C-056

## Primary Shaft Gear Assembly, Secondary Shaft Gear Assembly and Shift Fork Assembly

1. Remove the set bolt.

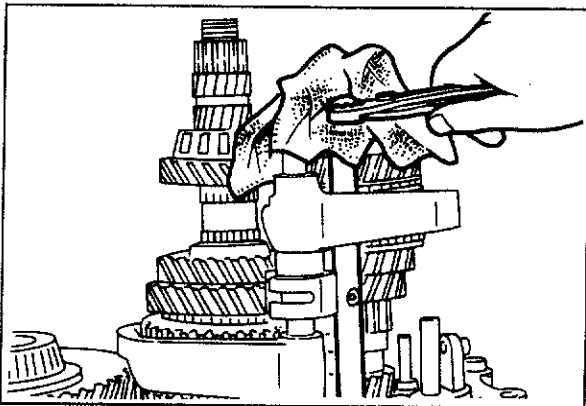

63G07C-057

2. To remove the reverse shift rod, wrap it with a cloth and turn it with pliers while pulling out.

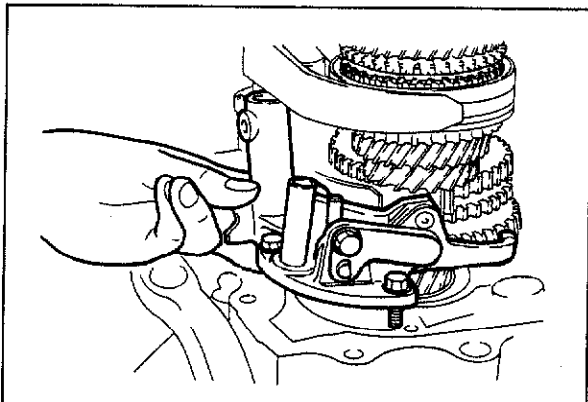

63G07C-058

3. Remove the shift gate and reverse lever support assembly.

4. Remove the bolt, spring and ball.

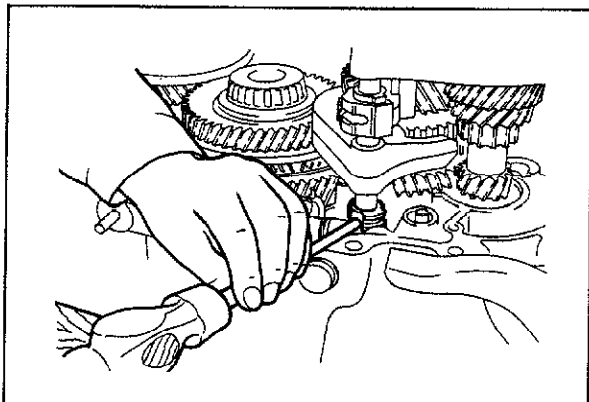

63G07C-059

5. Remove the spring pin.

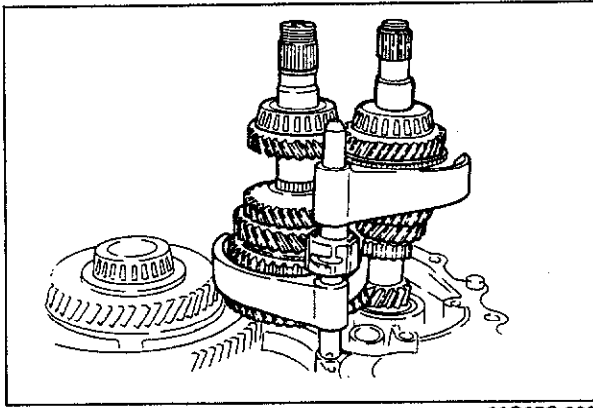

63G07C-060

6. Lift the primary shaft, secondary shaft and shift fork assemblies out as a unit.

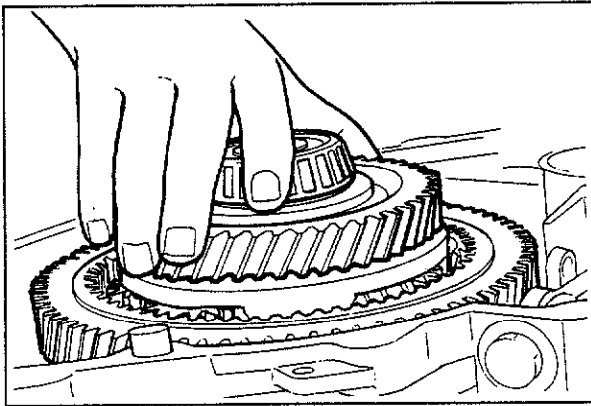

63G07C-061

### Center Differential

1. Remove the set bolt and remove the center differential assembly.
2. Remove the center differential lock shift fork.

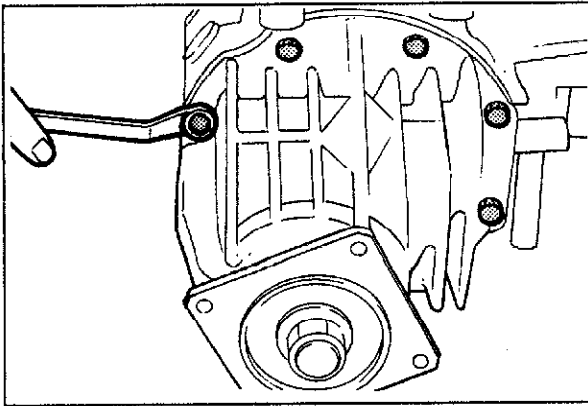

63G07C-062

### Transfer Carrier

1. Remove the speedometer driven gear.
2. Remove the transfer carrier.

## DISASSEMBLY-STEP 2

Disassemble in the sequence shown in the figure.

63G07C-303

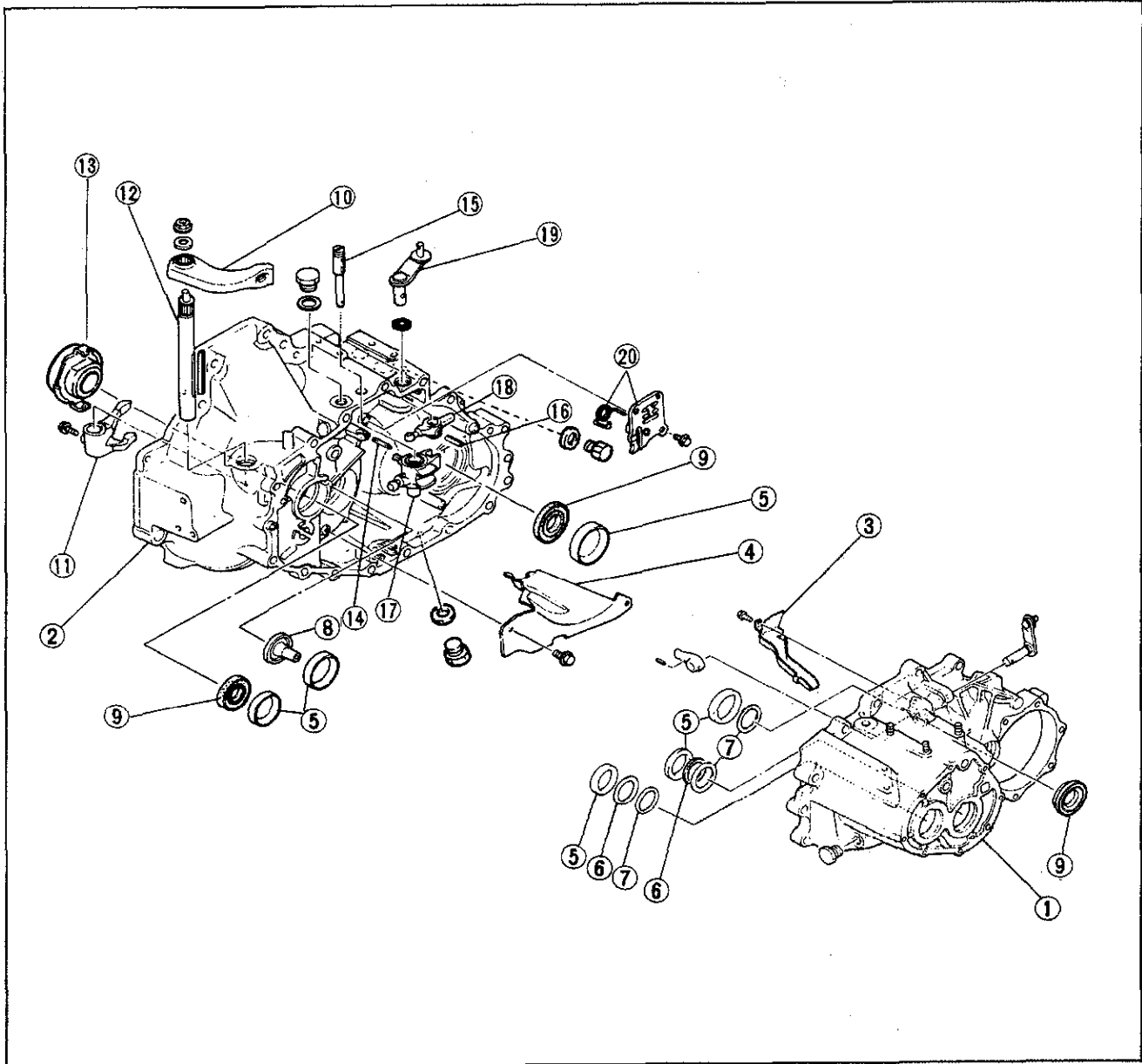

83U07C-010

- |                       |                           |
|-----------------------|---------------------------|
| 1. Transaxle case     | 11. Clutch release fork   |
| 2. Clutch housing     | 12. Clutch release shaft  |
| 3. Oil passage        | 13. Clutch release collar |
| 4. Baffle plate       | 14. Spring pin            |
| 5. Bearing outer race | 15. Crank lever shaft     |
| 6. Diaphragm spring   | 16. Spring pin            |
| 7. Washer(s)          | 17. Crank lever           |
| 8. Funnel             | 18. Inner shift lever     |
| 9. Oil seal           | 19. Select lever          |
| 10. Clutch lever      | 20. Base plate assembly   |

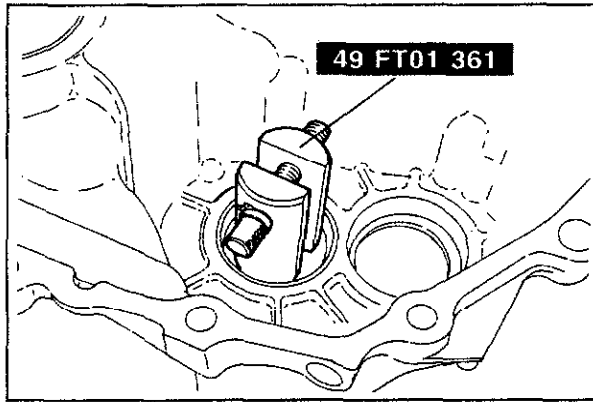

83U07C-064

## Bearing Outer Race

1. Install the SST .

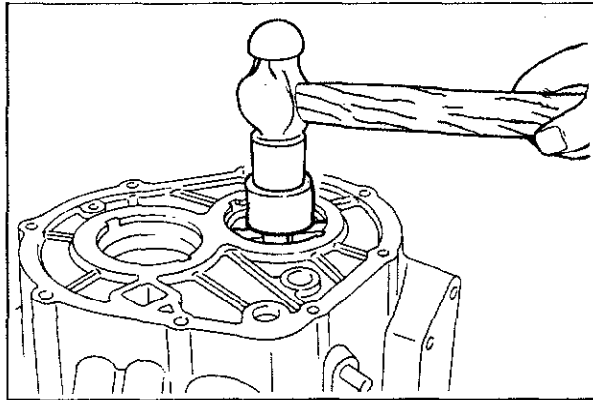

63G07C-065

2. Remove the bearing outer races.

### Note

**Do not remove the oil seals, unless replacement is necessary due to damage.**

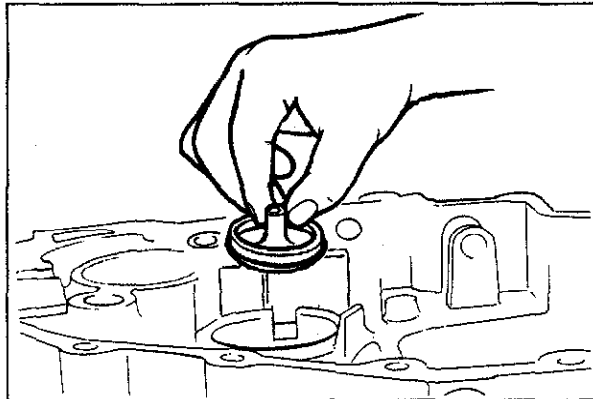

63G07C-066

3. Remove the bearing outer race by lifting the funnel and the race out together.

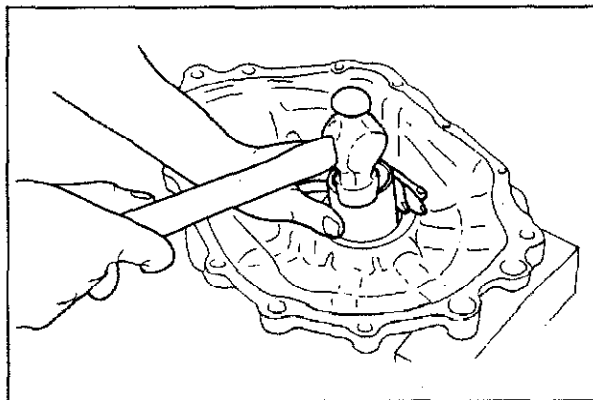

63G07C-067

### Oil Seal

Check the oil seals and if necessary replace them. Use a pipe of the proper size to tap the seal out.

### Note

**Remove the oil seal gradually and evenly.**



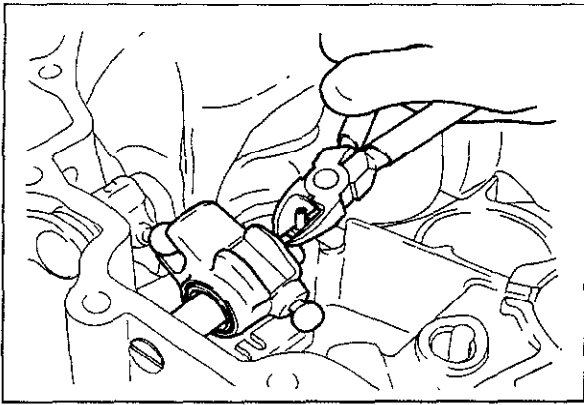

63G07C-068

## Clutch Housing

1. Remove the spring pin and crank lever.

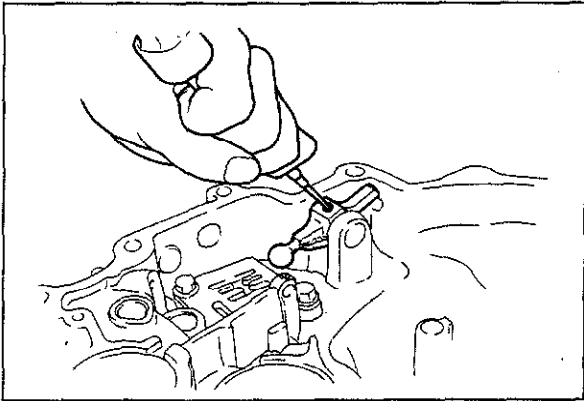

63G07C-069

2. Remove the spring pin and inner shift lever.

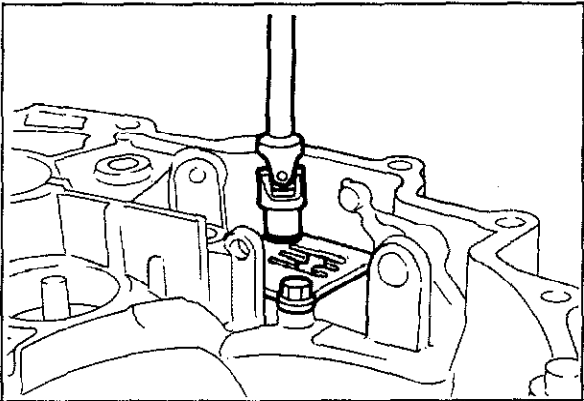

63G07C-070

3. Remove the base plate.

**DISASSEMBLY-STEP 3**

Disassemble in the sequence shown in the figure.

**Note**

a) Do not disassemble the bearing inner races (except the secondary 4th gear end ⑩ of the secondary shaft gear assembly and the 4th gear end ① of the primary shaft gear assembly) unless necessary. Replace them with new races whenever they are disassembled.

b) Before disassembly, check the thrust clearance of all gears. (Refer to page 7C—62)

63G07C-304

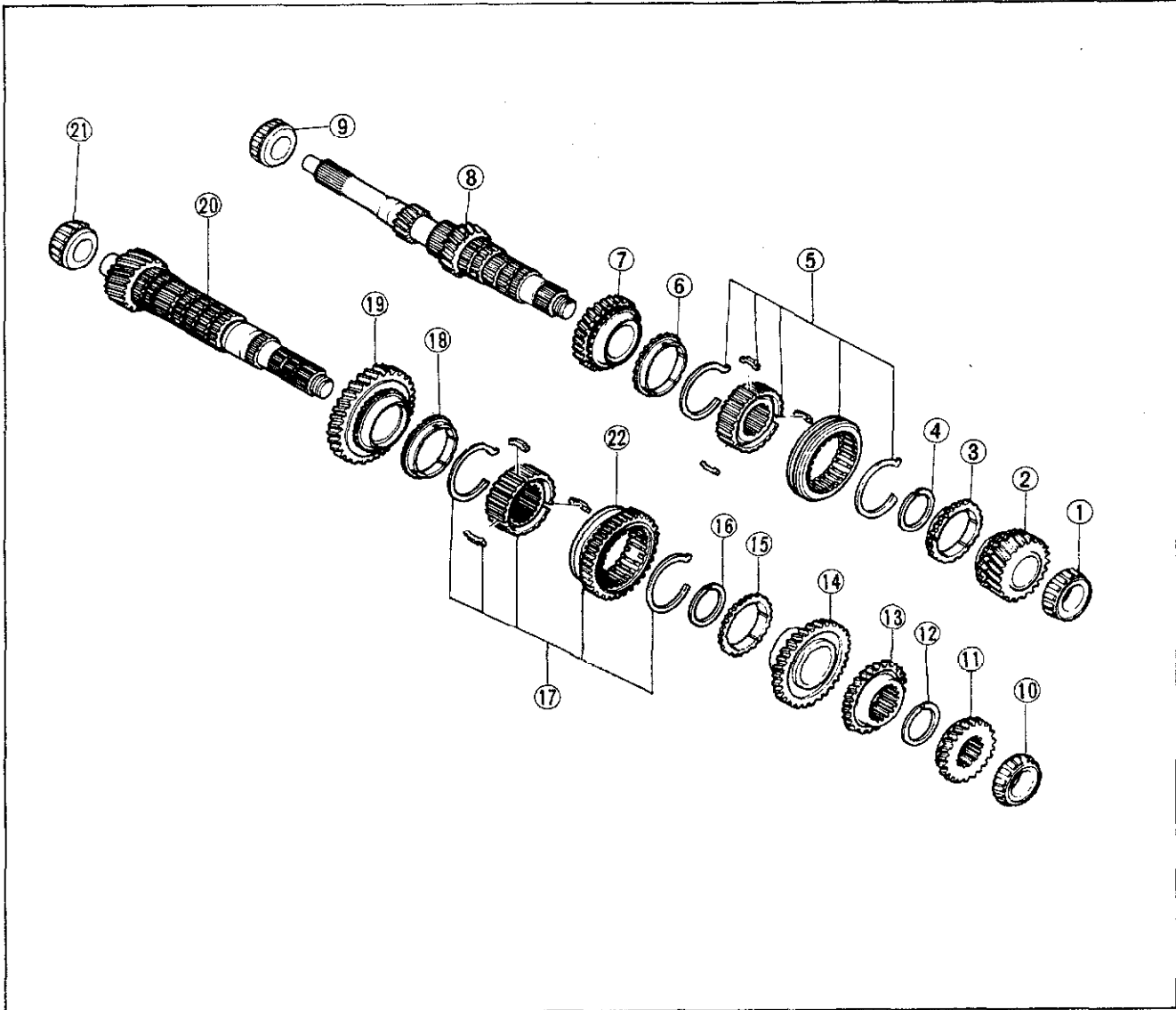

63G07C-071

- |                        |                        |                          |
|------------------------|------------------------|--------------------------|
| 1. Bearing inner race  | 8. Primary shaft gear  | 15. Synchronizer ring    |
| 2. 4th gear            | 9. Bearing inner race  | 16. Retaining ring       |
| 3. Synchronizer ring   | 10. Bearing inner race | 17. Clutch hub assembly  |
| 4. Retaining ring      | 11. Secondary 4th gear | 18. Synchronizer ring    |
| 5. Clutch hub assembly | 12. Retaining ring     | 19. 1st gear             |
| 6. Synchronizer ring   | 13. Secondary 3rd gear | 20. Secondary shaft gear |
| 7. 3rd gear            | 14. 2nd gear           | 21. Bearing inner race   |
|                        |                        | 22. Reverse gear         |

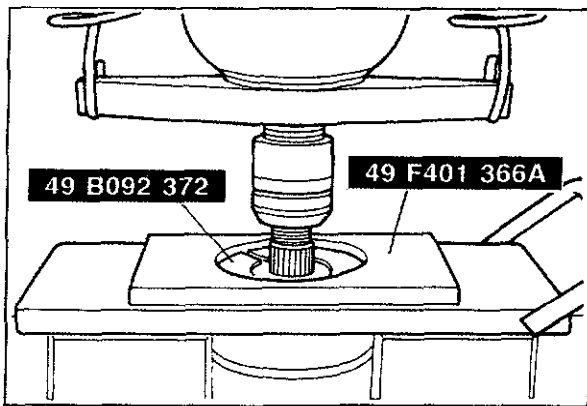

83U07C-065

## (PRIMARY SHAFT GEAR)

### Bearing Inner Race (4th gear end of primary shaft gear)

Press the bearing inner race from the shaft with the SST and a press.

#### Caution

Hold the shaft with one hand so that it does not fall.

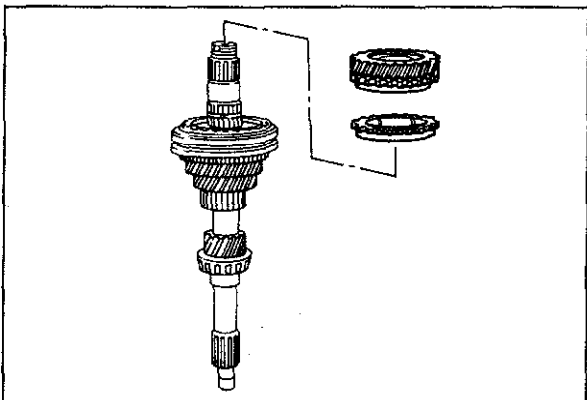

63G07C-073

## 4th Gear

Remove the 4th gear and synchronizer ring.

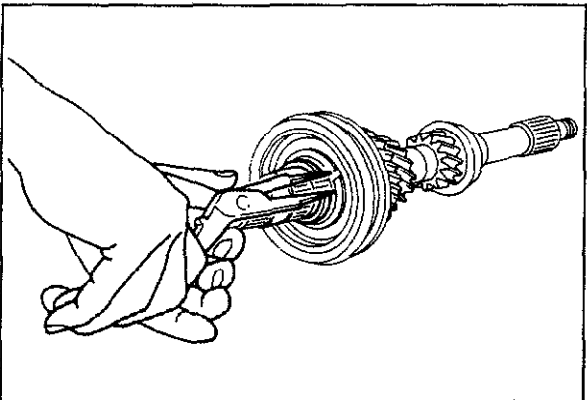

63G07C-074

## Clutch Hub Assembly (3rd-4th gear)

1. Remove the retaining ring.

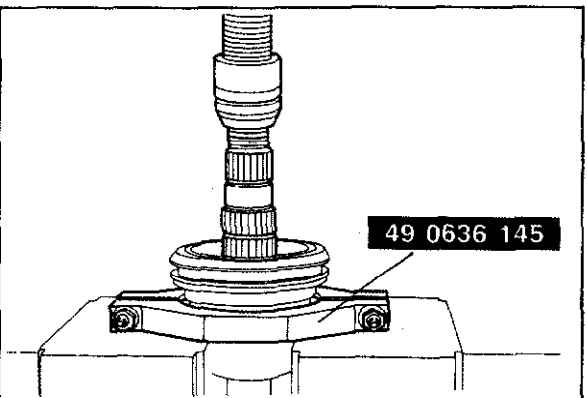

83U07C-066

2. Set the SST onto the 3rd gear, and then, using a press, remove the clutch hub assembly and 3rd gear.

#### Caution

Hold the shaft with one hand so that it does not fall.

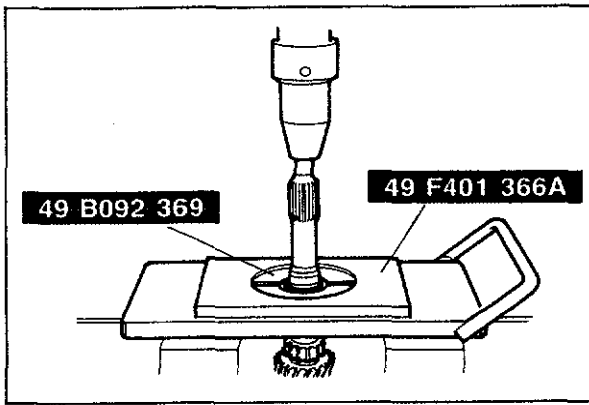

83U07C-067

**Bearing Inner Race (1st gear end of primary shaft gear)**

Press the bearing inner race from the shaft with the **SST** and a press.

**Caution**

Hold the shaft with one hand so that it does not fall.

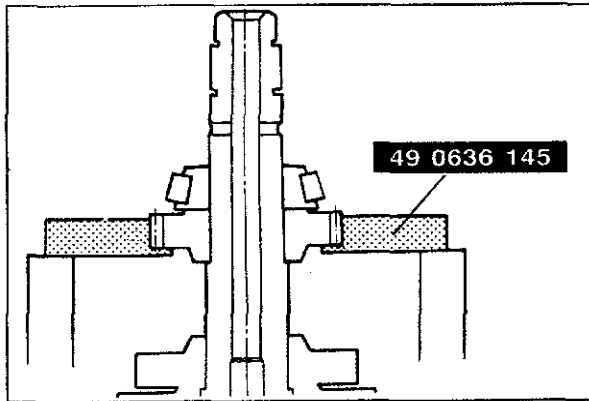

83U07C-068

**(SECONDARY SHAFT GEAR)****Bearing Inner Race and Secondary 4th Gear**

1. Set the **SST** onto the secondary 4th gear.

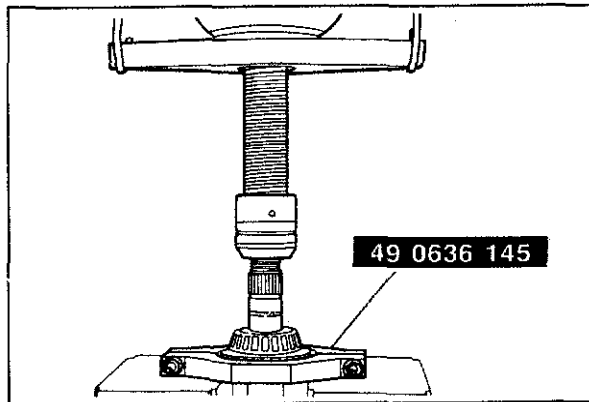

63G07C-078

2. Remove the bearing inner race and the secondary 4th gear.

**Caution**

Hold the shaft with one hand so that it does not fall.

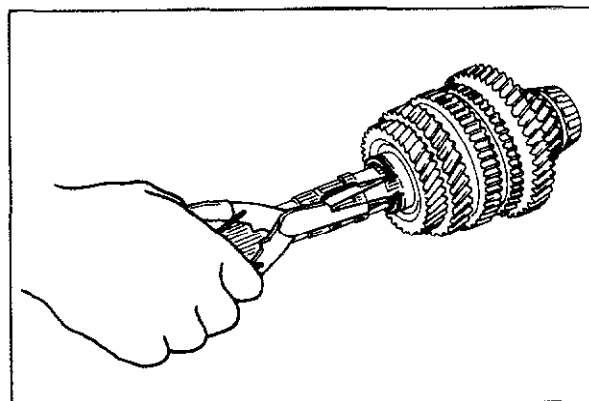

63G07C-079

**2nd Gear and Secondary 3rd Gear**

1. Remove the retaining ring.

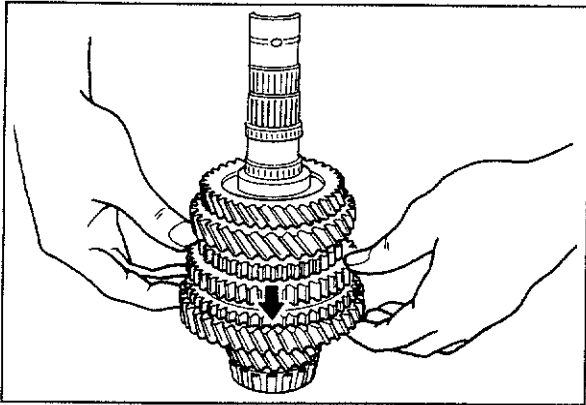

63G07C-080

2. Shift the clutch hub sleeve into 1st gear.

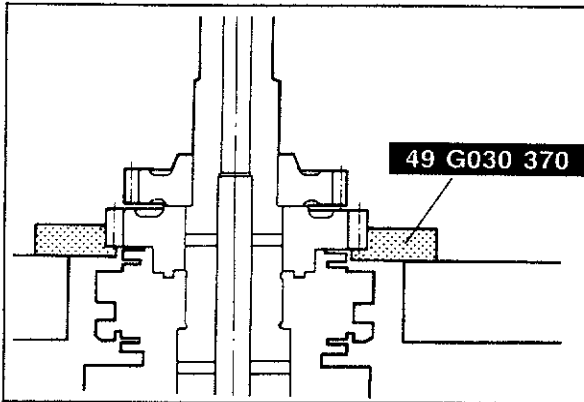

83U07C-069

3. Set the **SST** onto the 2nd gear.

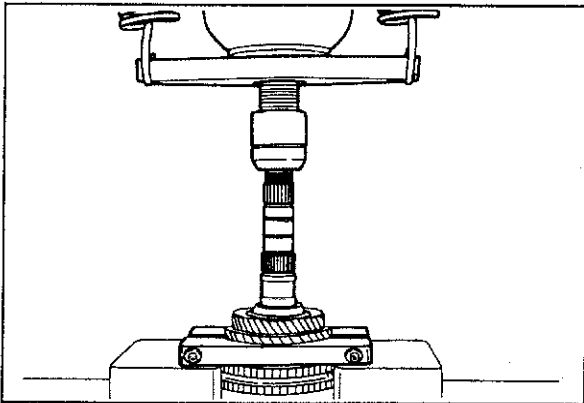

63G07C-082

4. Remove the 2nd gear and secondary 3rd gear with a press.

**Caution**  
Hold the shaft with one hand so that it does not fall.

## Clutch Hub Assembly and 1st Gear

1. Remove the retaining ring.

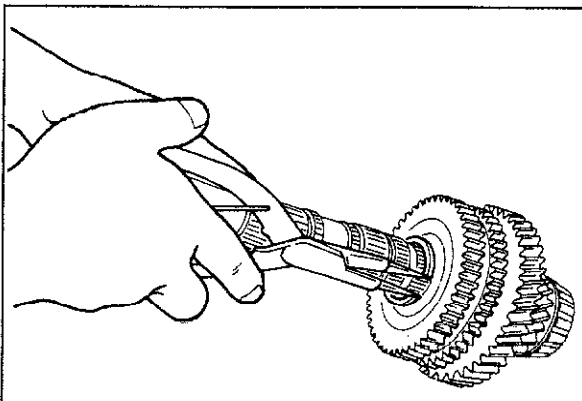

63G07C-083

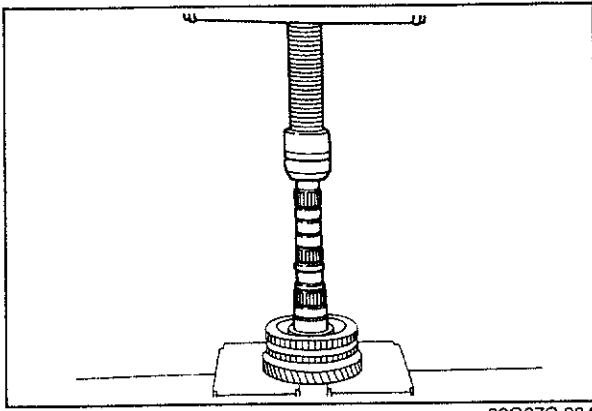

63G07C-084

- Support the 1st gear and remove the clutch hub assembly and 1st gear with a press.

**Caution**

Hold the shaft with one hand so that it does not fall.

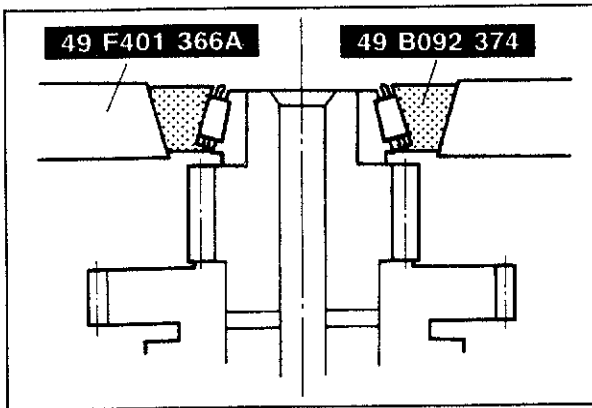

83U07C-070

**Bearing Inner Race**

Remove the bearing inner race from the shaft with the **SST** and press against the shaft with a proper rod.

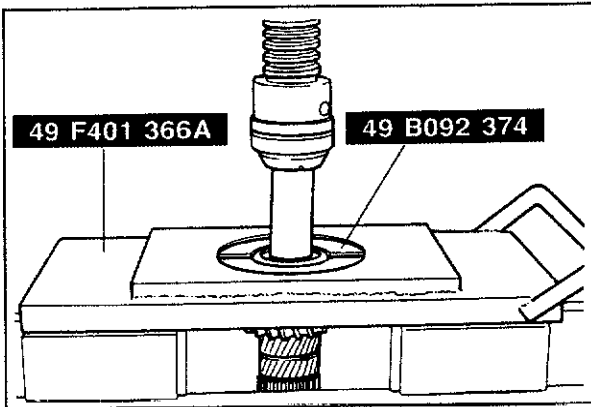

63G07C-086

**Caution**

Hold the shaft with one hand so that it does not fall.

## DISASSEMBLY-STEP 4

Disassemble in the sequence shown in the figure.

63G07C-305

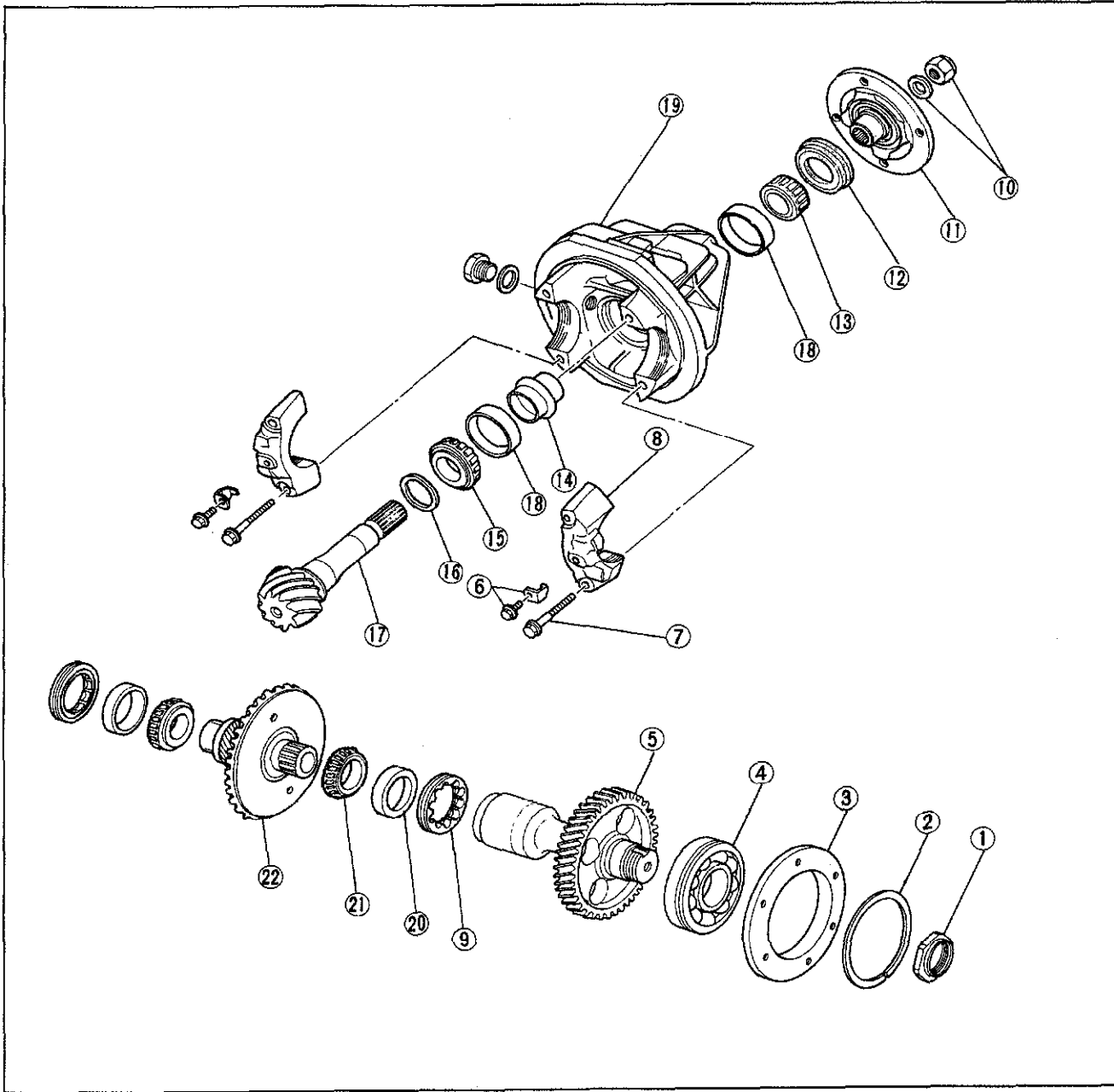

63G07C-087

- 1. Lock nut
- 2. Retaining ring
- 3. Side cover (B)
- 4. Bearing
- 5. Idle gear
- 6. Lock plate and bolt
- 7. Bolt

- 8. Bearing cap
- 9. Adjustment screw
- 10. Washer and lock nut
- 11. Companion flange
- 12. Oil seal
- 13. Bearing inner race
- 14. Collapsible spacer

- 15. Bearing inner race
- 16. Spacer
- 17. Drive pinion
- 18. Bearing outer race
- 19. Transfer carrier
- 20. Bearing outer race
- 21. Bearing inner race
- 22. Differential gear

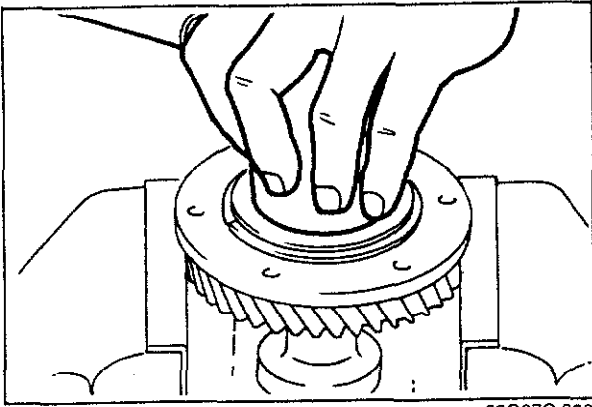

63G07C-088

**Idle Gear**

1. Secure the idle gear in a vise.
2. Uncrimp the tab of the lock nut.
3. Remove the lock nut.

**Note**

**Use pads in the vise**

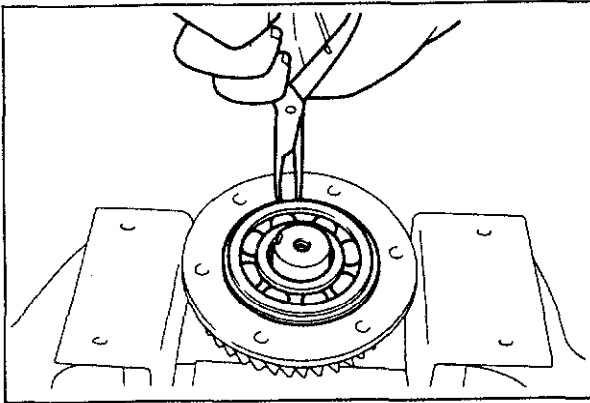

63G07C-089

4. Remove the retaining ring.

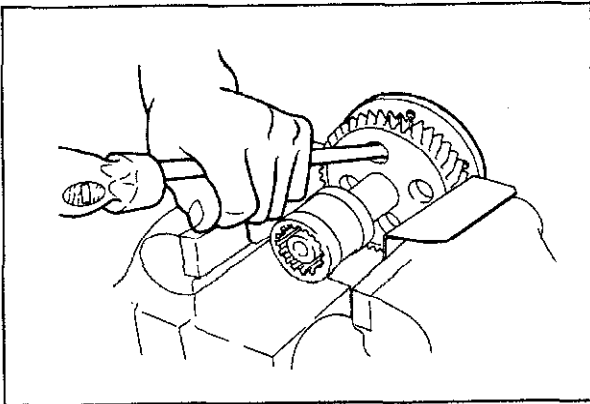

63G07C-090

5. Tap the bearing and remove the side cover (B) and bearing.

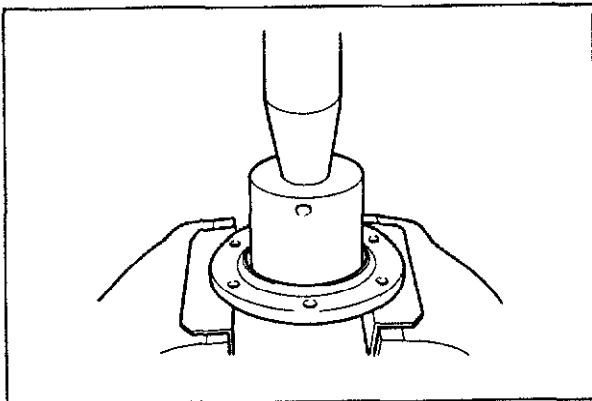

63G07C-091

6. Remove the bearing from the side cover (B) using a suitable pipe.



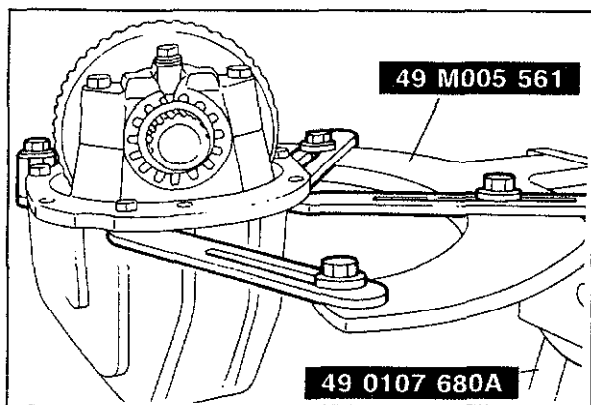

83U07C-071

## Transfer Carrier

1. Position the **SST** and mount the transfer carrier.

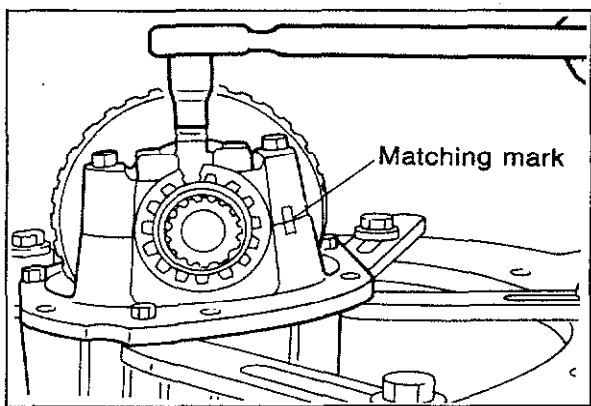

63G07C-093

## Adjustment Screw

1. Make matching marks on the carrier and caps.
2. Remove the bolts, lock plates and the bearing caps.

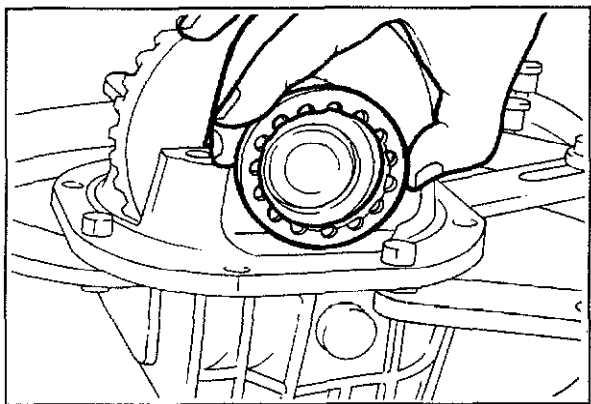

63G07C-094

3. Remove the adjustment screw.

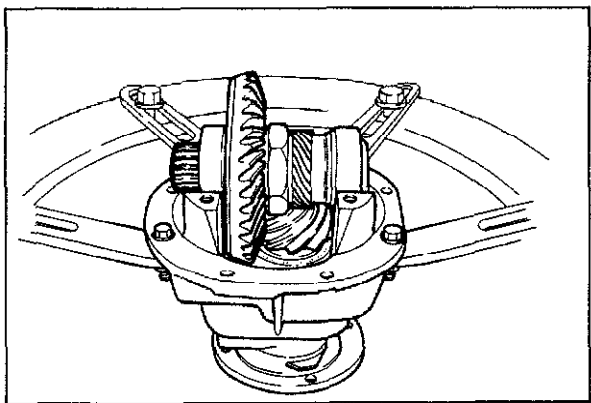

63G07C-095

## Differential Gear

1. Remove the differential gear.

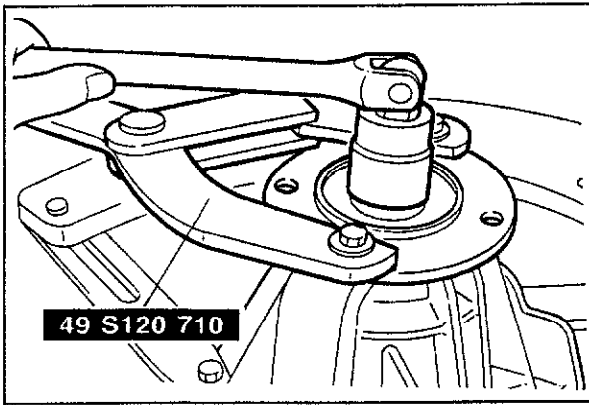

83U07C-072

## Drive Pinion

1. Remove the lock nut with the **SST**.

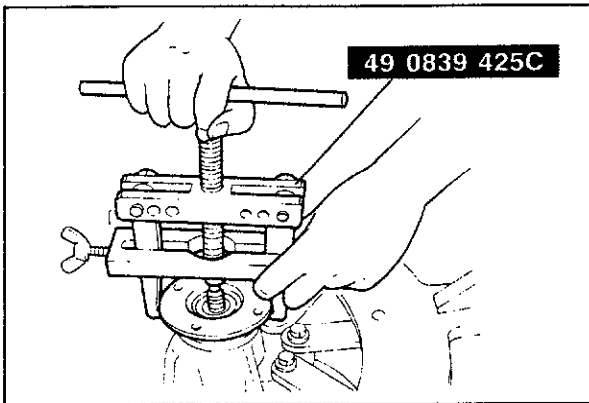

83U07C-073

2. Remove the companion flange with the **SST**.

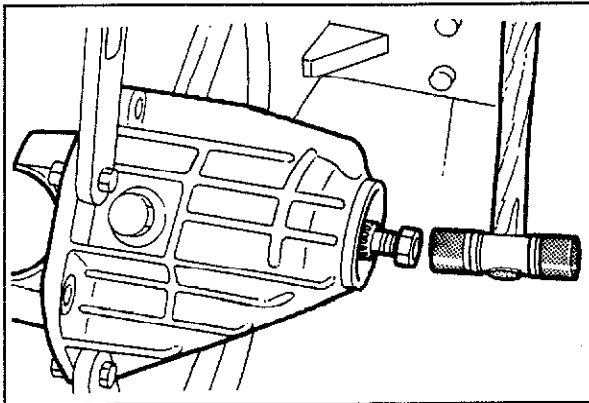

63G07C-098

3. Push the drive pinion out by attaching a miscellaneous lock nut to the drive pinion, and tapping it with a copper hammer.

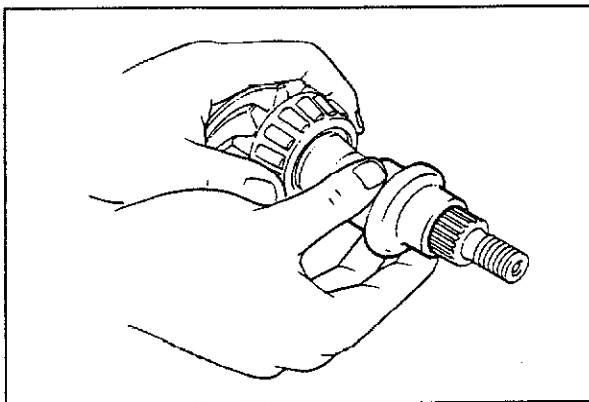

63G07C-099

4. Remove the collapsible spacer.

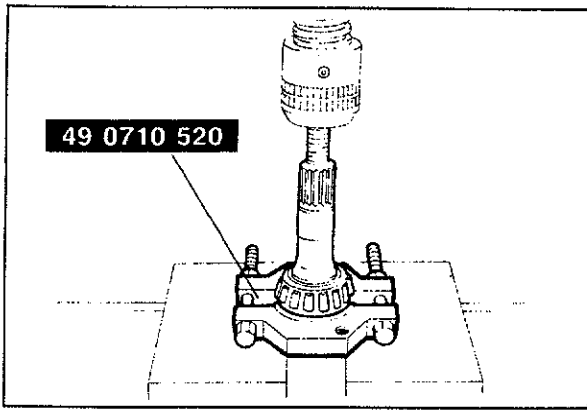

83U07C-074

5. Remove the bearing with the **SST**.

**Caution**

**Support the drive pinion by hand so that it will not fall.**

6. Remove the spacer.

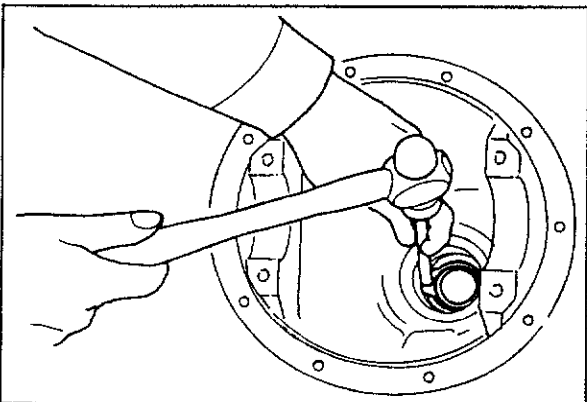

63G07C-101

**Bearing Outer Race (Carrier)**

1. Using a brass drift and hammer drive out the bearing.
2. Remove the bearing outer races by using the two grooves in the carrier and tapping the races alternately.

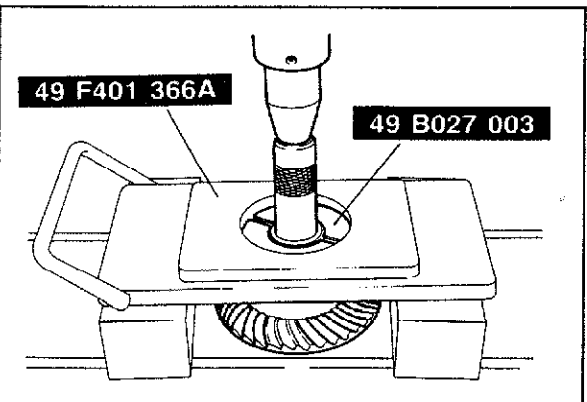

83U07C-011

**Bearing Inner Race (Differential gear)**

1. Remove the bearing inner race with the **SST**.

**Note**

**Do not disassemble the bearing inner race unless necessary.**

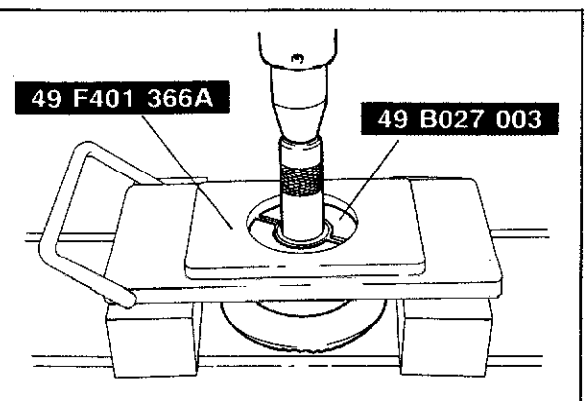

83U07C-012

2. Remove the bearing inner race with the **SST**.

**Note**

**Do not disassemble the bearing inner race unless necessary.**

**DISASSEMBLY-STEP 5**

Disassemble in the sequence shown in the figure.

63G07C-306

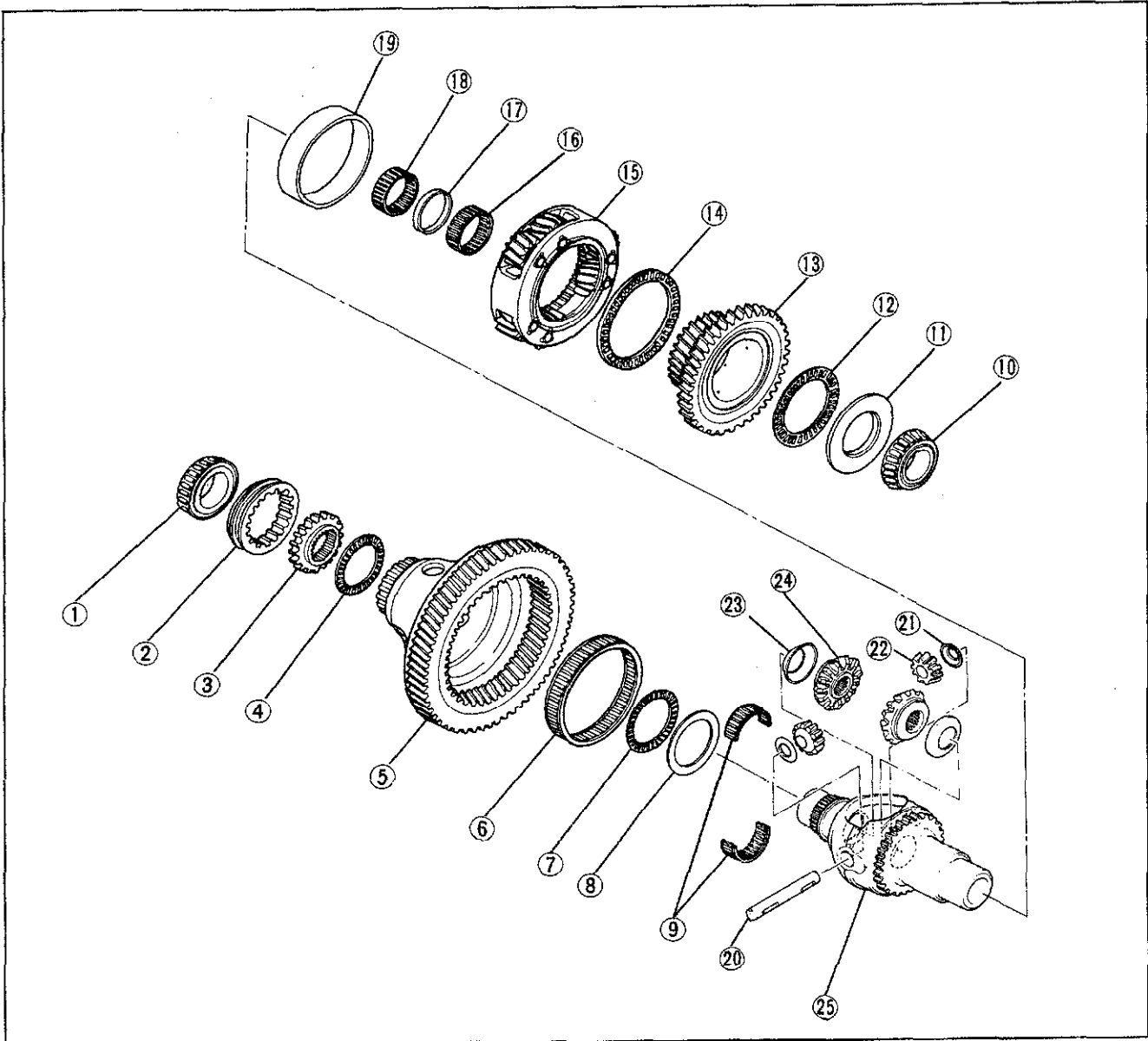

63G07C-139

- |                                    |                                   |
|------------------------------------|-----------------------------------|
| 1. Bearing inner race              | 13. Sun gear                      |
| 2. Differential lock gear sleeve   | 14. Gear case needle bearing      |
| 3. Differential lock hub           | 15. Planetary carrier             |
| 4. Gear case needle bearing        | 16. Gear case needle bearing      |
| 5. Ring gear case                  | 17. Spacer                        |
| 6. Gear case needle bearing        | 18. Gear case needle bearing      |
| 7. Gear case needle bearing        | 19. Differential gear case sleeve |
| 8. Differential lock thrust washer | 20. Pinion shaft                  |
| 9. Gear case needle bearing        | 21. Washer                        |
| 10. Bearing inner race             | 22. Pinion gear                   |
| 11. Thrust washer                  | 23. Washer                        |
| 12. Gear case needle bearing       | 24. Side gear                     |
|                                    | 25. Differential gear case        |

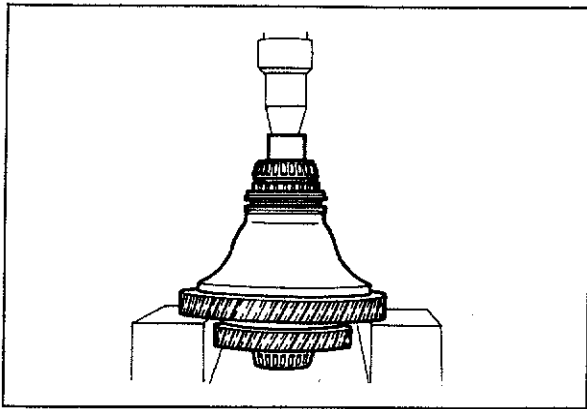

63G07C-105

## Center Differential

1. Remove the bearing inner race from the center differential with a suitable pipe.

### Caution

**Hold the center differential with one hand so that it does not fall.**

2. Remove the differential lock gear sleeve, differential lock hub and gear case needle bearing.
3. Remove the gear case needle bearings and differential lock thrust washer.

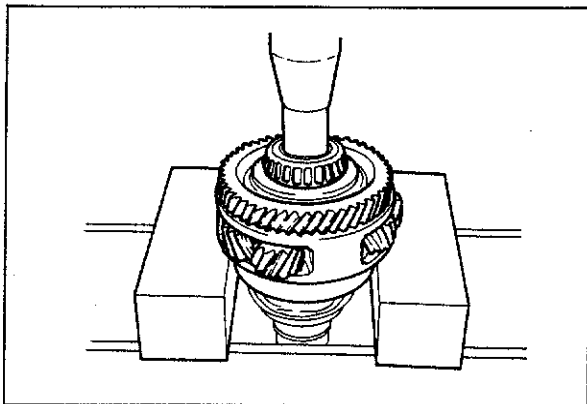

63G07C-107

4. Remove the bearing inner race using a press, then remove the washer, gear case needle bearing, sun gear, planetary carrier and gear case needle bearing.

### Note

**Do not disassemble the planetary carrier assembly.**

5. Remove the gear case needle bearings and spacer.

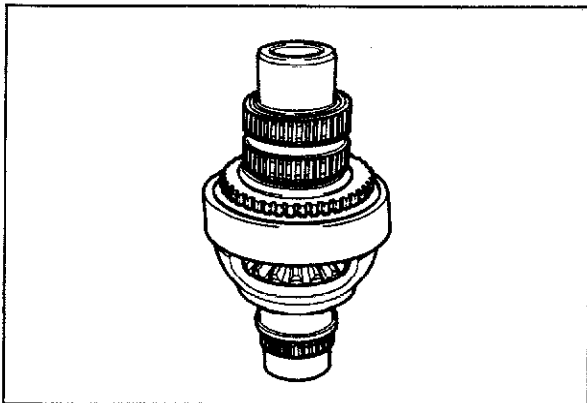

63G07C-108

6. Remove the differential gear case sleeve.

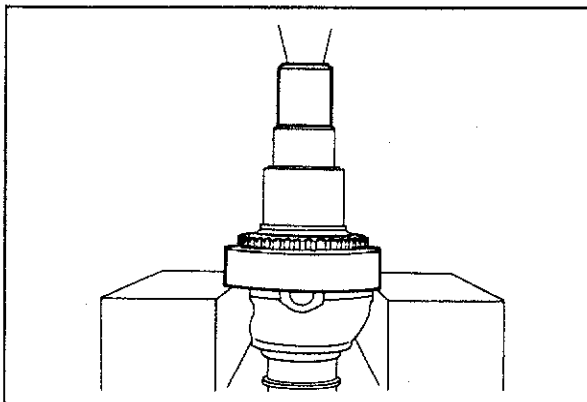

63G07C-109

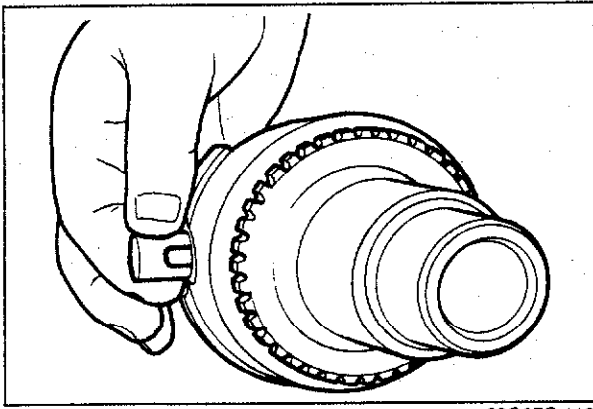

63G07C-110

- Front Differential**  
1. Remove the pinion shaft.

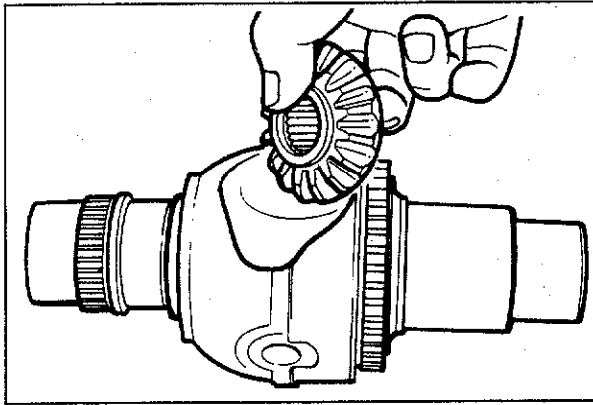

63G07C-111

2. Remove the side gears and pinion gears.

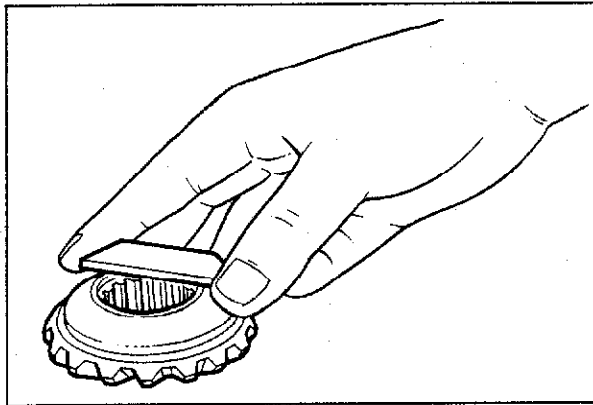

63G07C-112

3. Remove the washers.

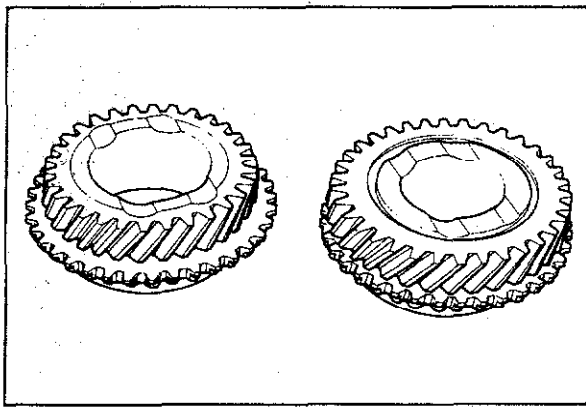

63G07C-113

## INSPECTION

Check the following parts, replace if necessary:

### 1st, 2nd, 3rd, 4th, and 5th gears.

1. Worn or damaged synchronizer cone.
2. Worn or damaged hub sleeve coupling.
3. Worn or damaged teeth.
4. Worn or damaged inner surface or end surface of gears.

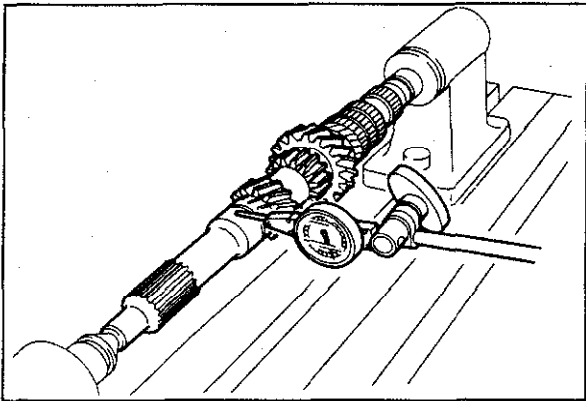

63G07C-114

### Primary Shaft Gear

1. Worn teeth.
2. Primary shaft gear run-out.

**Maximum run-out: 0.03 mm (0.001 in)**

### Note

**If the shaft gear is replaced, adjust the bearing preload. (Refer to Page 7C—65)**

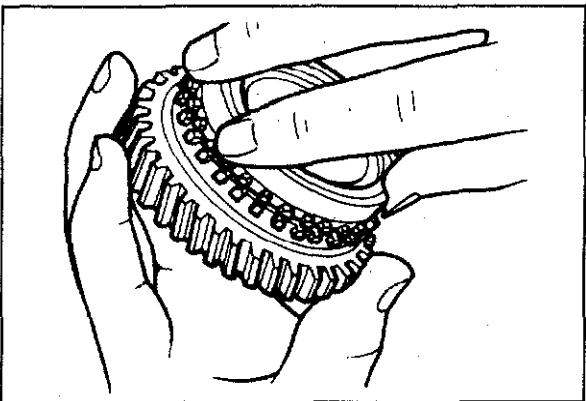

63G07C-115

### Synchronizer Ring

1. Engagement with gear.
2. Worn or damaged teeth.
3. Worn or damaged tapered surface.

4. Clearance from the side of gear.

**Standard: 1.5 mm (0.059 in)**

**Minimum: 0.8 mm (0.031 in)**

### Note

- a) **Press the synchronizer ring uniformly against the gear and measure around the circumference.**
- b) **If the measured value is less than the minimum replace the synchronizer ring or gear.**

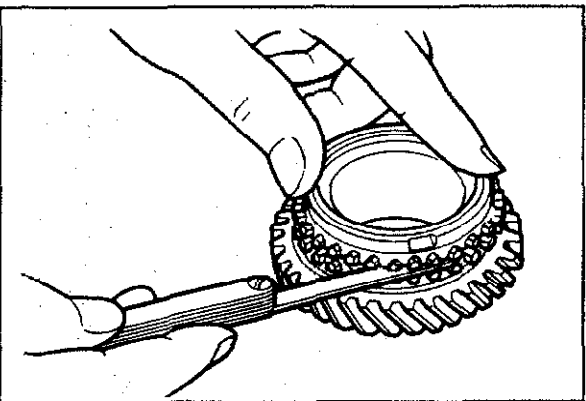

63G07C-116

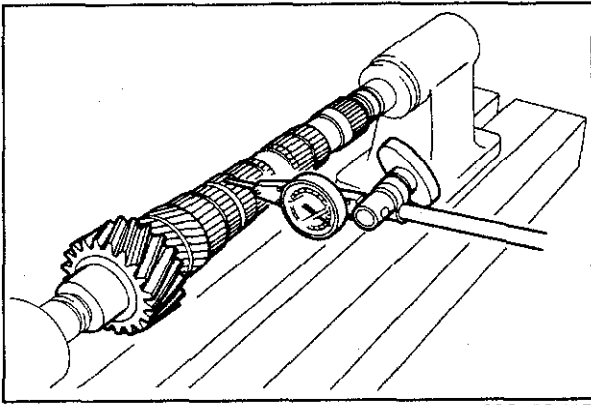

63G07C-117

### Secondary Shaft Gear

1. Worn or damaged gear contact surface.
2. Worn or damaged splines.
3. Worn teeth.
4. Clogged oil passage.
5. Secondary shaft gear run-out.

**Maximum run-out: 0.03 mm (0.001 in)**

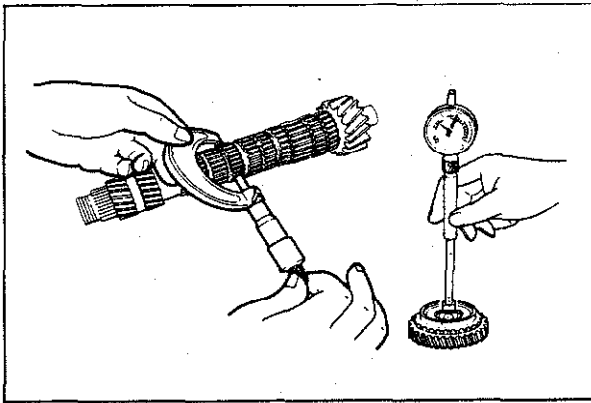

83U07C-013

6. Oil clearance between the gear shaft and gears.

**Standard: 0.03—0.08 mm (0.001—0.003 in)**

### Note

**If the shaft gear is replaced, adjust the bearing preload.**

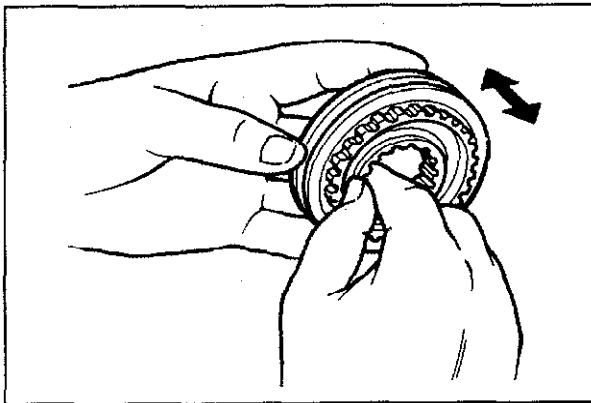

63G07C-119

### Clutch Hub

1. Worn or damaged splines.
2. Worn or damaged synchronizer key groove.
3. Worn end surface.
4. Operation of the hub sleeve when it is installed.

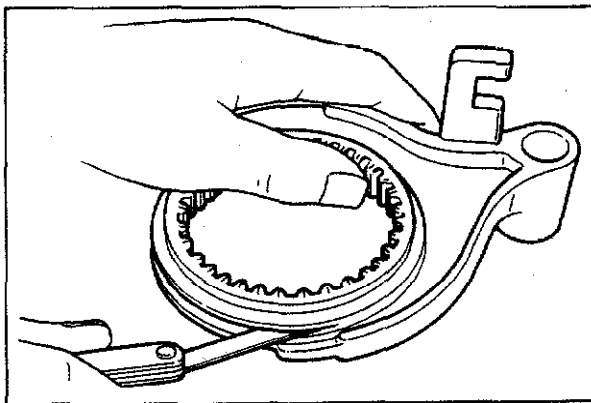

83U07C-075

### Clutch Hub Sleeve

1. Worn or damaged hub splines.
2. Worn or damaged sleeve fork groove.
3. Clearance between sleeve and shift fork.

**Standard: 0.2—0.4 mm (0.008—0.016 in)**

**Maximum: 0.5 mm (0.020 in)**



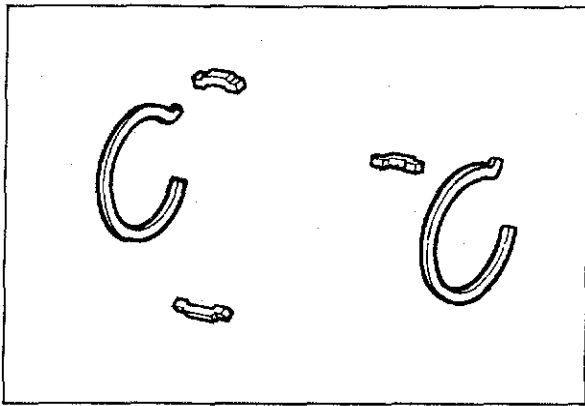

63G07C-121

## Synchronizer Key and Key Spring

1. Worn key.
2. Fatigued or damaged spring.

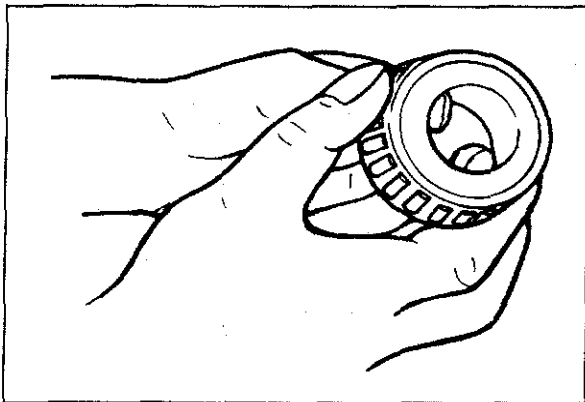

63G07C-122

## Bearing

1. Roughness or noise while turning.
2. Damaged bearing
3. Worn bearing.

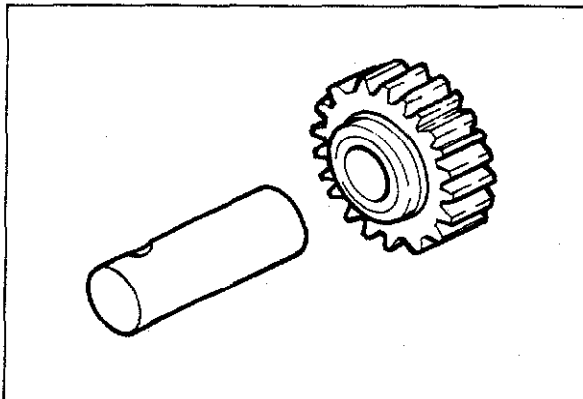

63G07C-123

## Reverse Idle Gear and Shaft

1. Worn or damaged gear.
2. Worn shaft.

### Standard clearance:

0.1—0.32 mm (0.004—0.013 in)

Maximum: 0.5 mm (0.02 in)

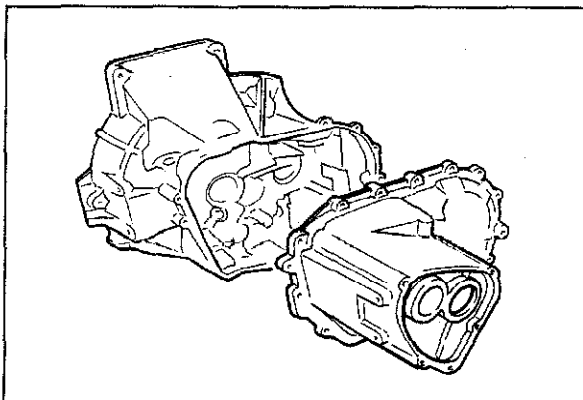

63G07C-124

## Clutch Housing and Transaxle Case

Cracks or damage.

### Note

If the clutch housing or transaxle case is replaced, adjust the bearing preload of the shaft gears and the preload of the differential side bearings.

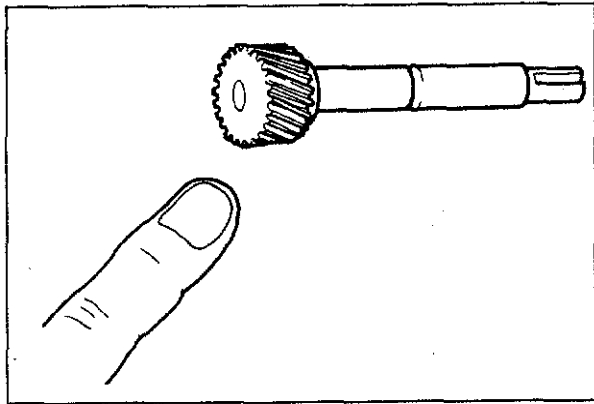

63G07C-125

**Speedometer Driven Gear Assembly**

1. Worn or damaged teeth.
2. Worn or damaged "O" ring.

**Ring Gear Speedometer Drive Gear**

Worn or damaged teeth.

**Oil Seal**

Damaged or worn lip.

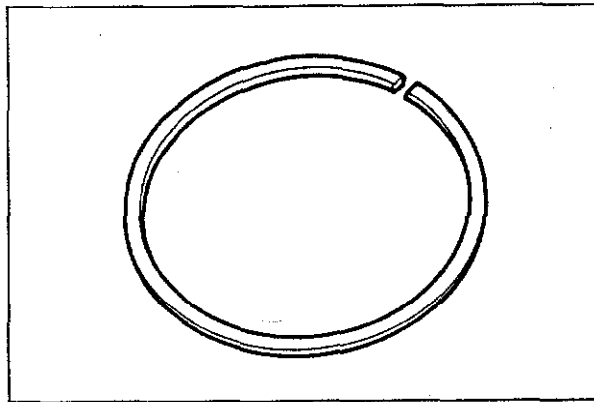

63G07C-126

**Retaining Ring**

Bent ring.

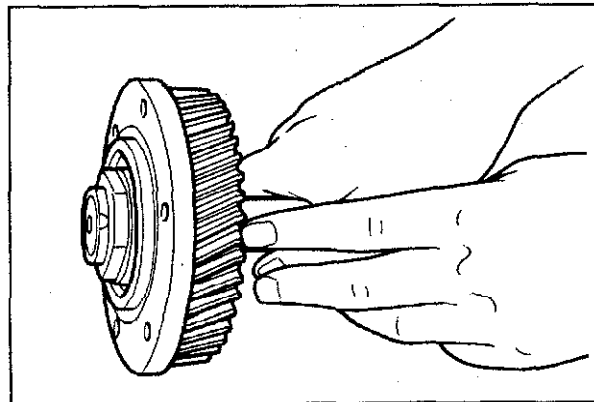

63G07C-127

**Idle Gear**

Worn or damaged teeth.

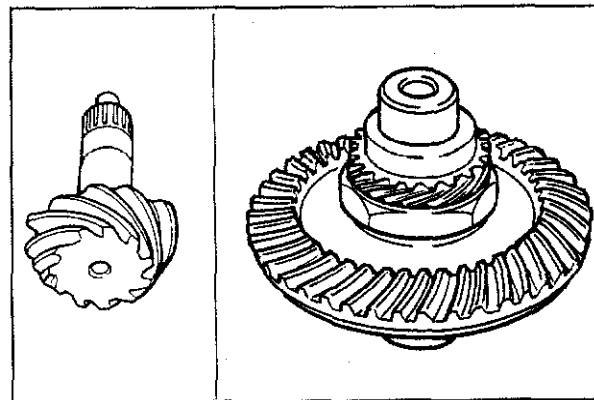

63G07C-128

**Drive Pinion and Ring Gear**

Poor contact, wear or damage.

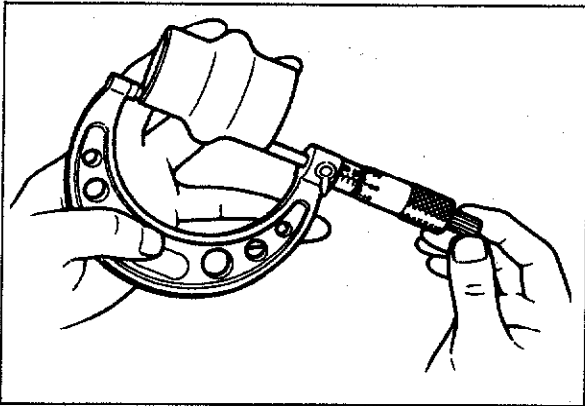

63G07C-129

### Collapsible Spacer

Measure the length of the collapsible spacer.

### Standard length:

43.35—43.65 mm (1.701—1.719 in)

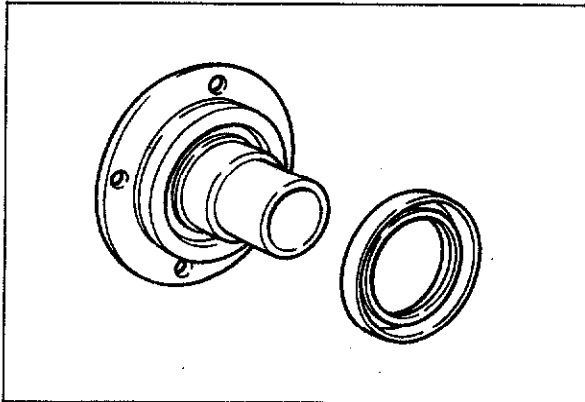

67U09X-105

### Companion Flange and Oil Seal

1. Check the oil seal for wear or damage.
2. Check the companion flange for cracks, worn splines, or rough oil seal contact surface.

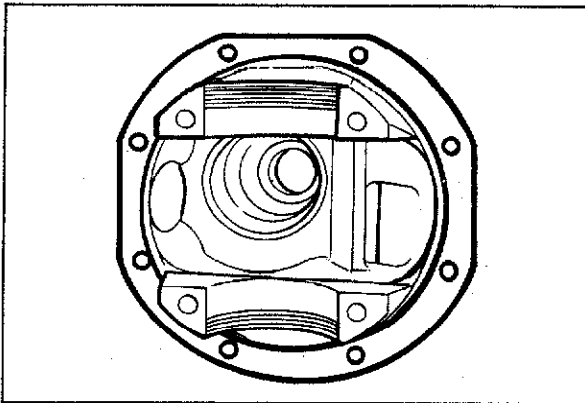

63G07C-130

### Transfer Carrier

Cracks or damage.

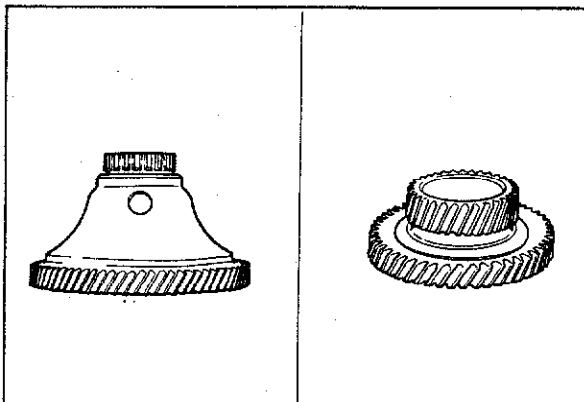

63G07C-131

### Ring Gear Case and Sun Gear

Worn or damaged.

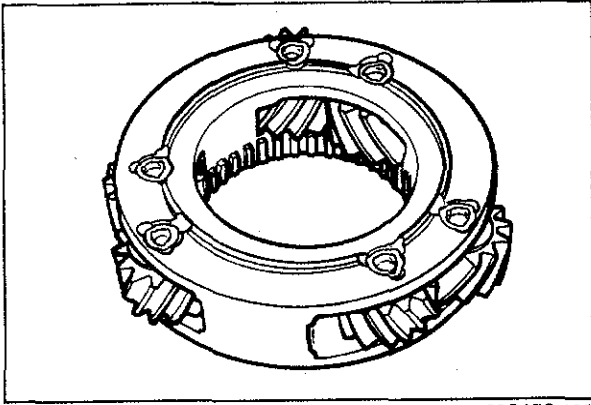

63G07C-132

**Planetary Carrier Assembly**  
Engagement with pinion gears.

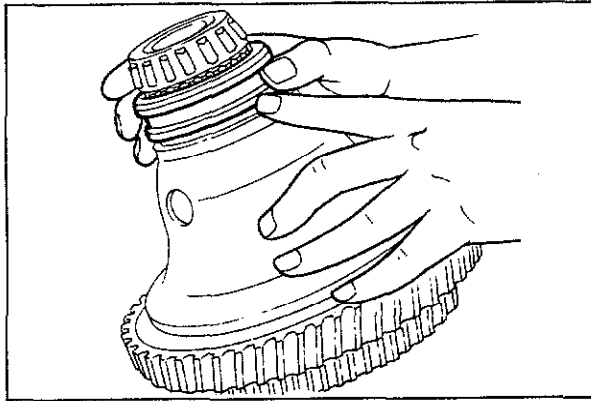

63G07C-133

**Differential Lock Gear Sleeve**  
Worn or damaged.

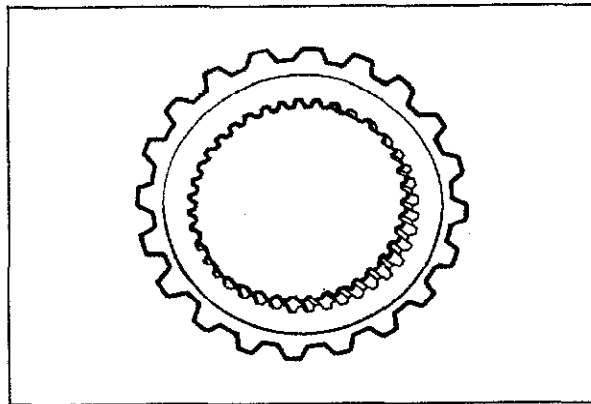

63G07C-134

**Differential Lock Hub**  
Worn or damaged.

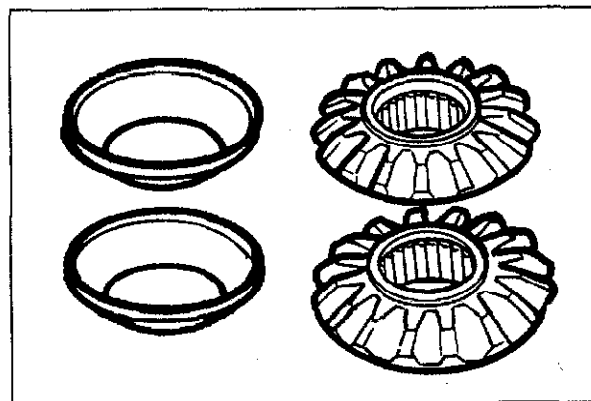

63G07C-135

**Side Gear, Pinion Gear and Washer**  
Worn or damaged.

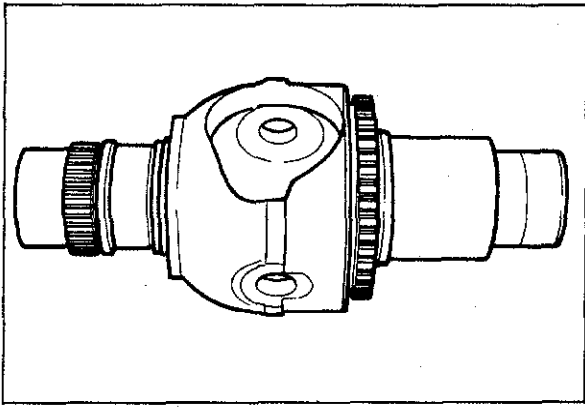

63G07C-136

**Differential Gear Case**  
Worn or damaged.

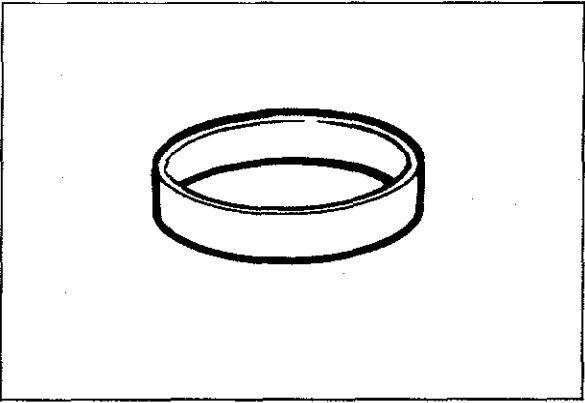

63G07C-137

**Differential Gear Case Sleeve**  
Worn or damaged.

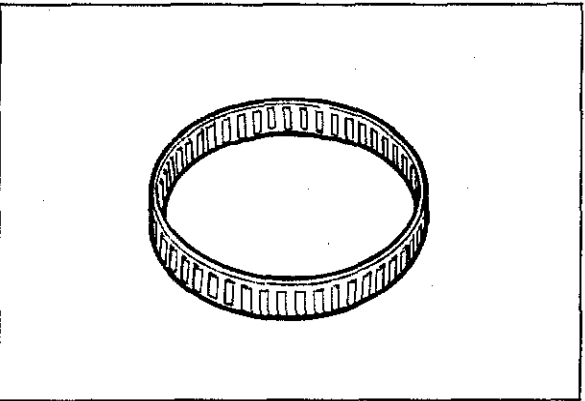

63G07C-138

**Gear Case Needle Bearing**  
Worn or damaged.

**ASSEMBLY**

**ASSEMBLY-STEP 1**

Assemble in the sequence shown in the figure.

83U07C-014

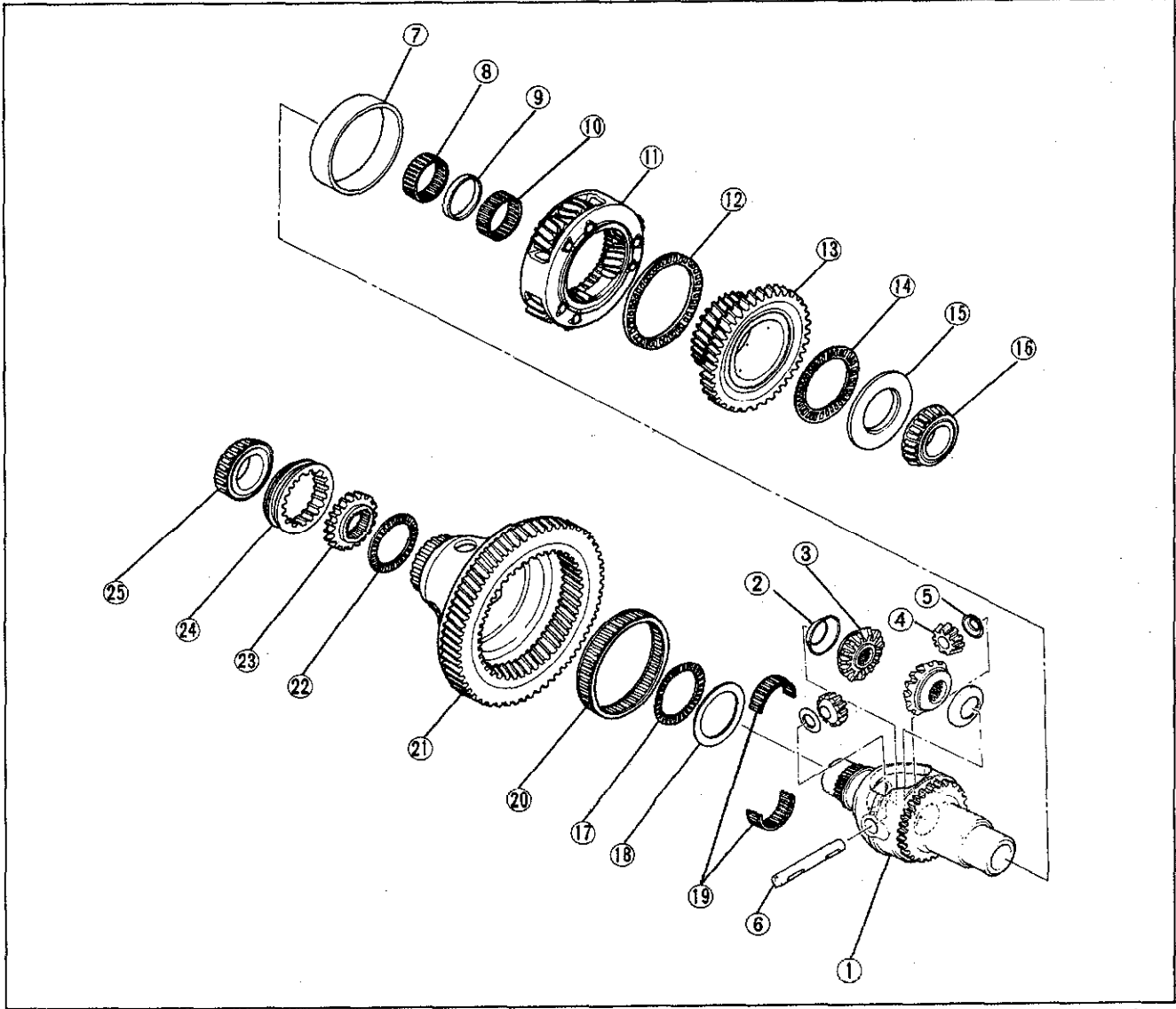

63G07C-104

- |                                  |                                     |
|----------------------------------|-------------------------------------|
| 1. Differential gear case        | 14. Gear case needle bearing        |
| 2. Washer                        | 15. Thrust washer                   |
| 3. Side gear                     | 16. Bearing inner race              |
| 4. Pinion gear                   | 17. Gear case needle bearing        |
| 5. Washer                        | 18. Differential lock thrust washer |
| 6. Pinion shaft                  | 19. Gear case needle bearing        |
| 7. Differential gear case sleeve | 20. Gear case needle bearing        |
| 8. Gear case needle bearing      | 21. Ring gear case                  |
| 9. Spacer                        | 22. Gear case needle bearing        |
| 10. Gear case needle bearing     | 23. Differential lock hub           |
| 11. Planetary carrier            | 24. Differential lock gear sleeve   |
| 12. Gear case needle bearing     | 25. Bearing inner race              |
| 13. Sun gear                     |                                     |

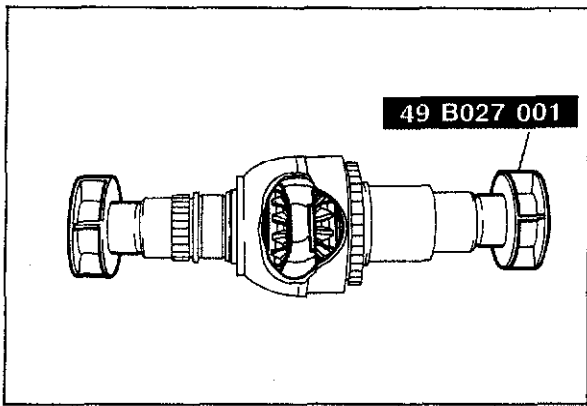

## Front Differential

1. Install the side gears and washers, and fix them with the **SST**.

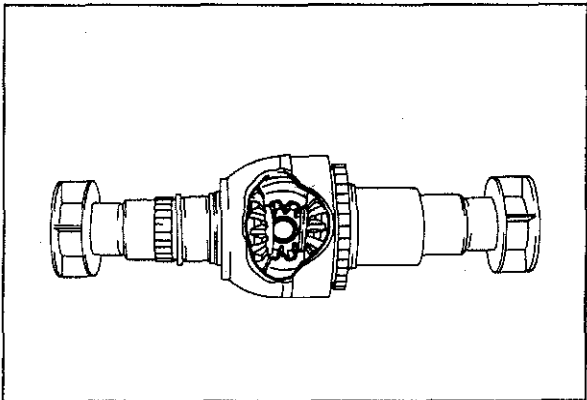

2. Install a pinion gear and turn it 180°.

### Note

**Do not install the washer at this time.**

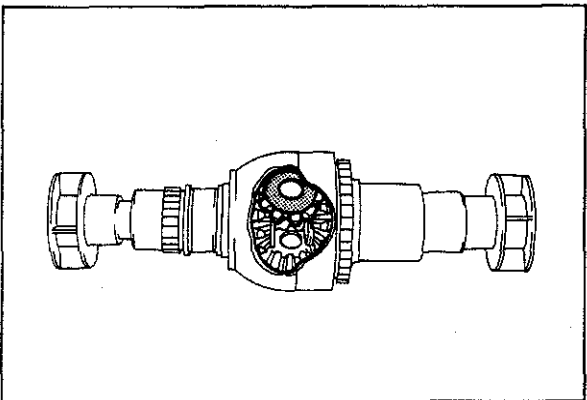

3. Install the other pinion gear and washer.
4. Turn the pinion gear and washer 150°.
5. Install the washer on opposite pinion gear.

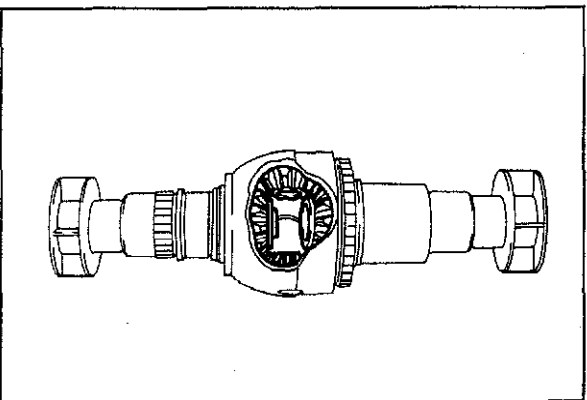

6. Align the pinion shaft holes of the pinion gears with the differential gear case.

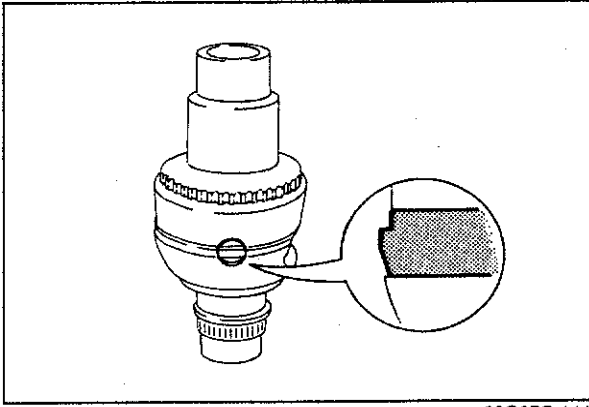

63G07C-144

7. Insert the pinion shaft.

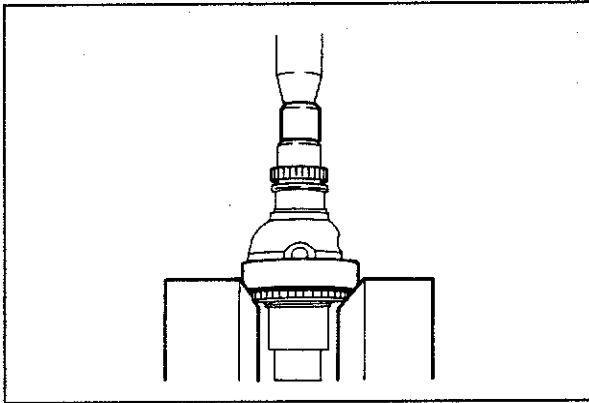

63G07C-145

**Center Differential**

1. Install the differential gear case sleeve.

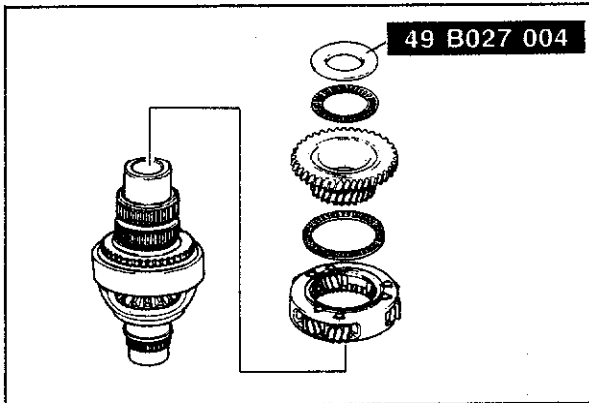

83U07C-077

- 2. Install the gear case needle bearings and spacer.
- 3. Install the planetary carrier assembly, gear case needle bearing, sun gear, gear case needle bearing and the **SST**.

**Note**

**Apply transaxle oil to the needle bearings.**

**Measuring plate thickness: 4.3 mm (0.169 in)**

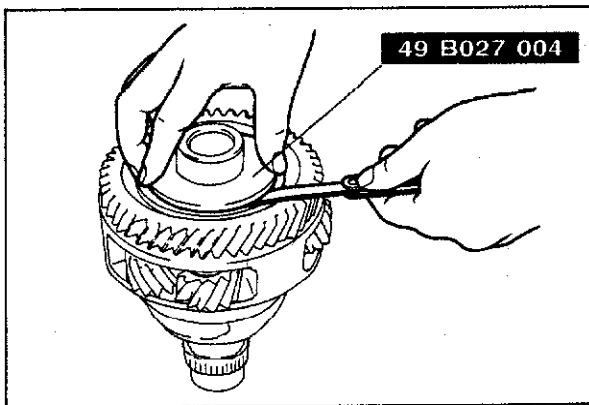

83U07C-078

- 4. Measure the clearance between the **SST** and gear case needle bearing.  
If the clearance is not within specification, select the proper washer.

**Standard: 0.1—0.3 mm (0.004—0.012 in)**

**Available washer thickness:**

- 3.5 mm (0.138 in) 3.7 mm (0.146 in)
- 3.9 mm (0.154 in) 4.1 mm (0.161 in)
- 4.3 mm (0.169 in)



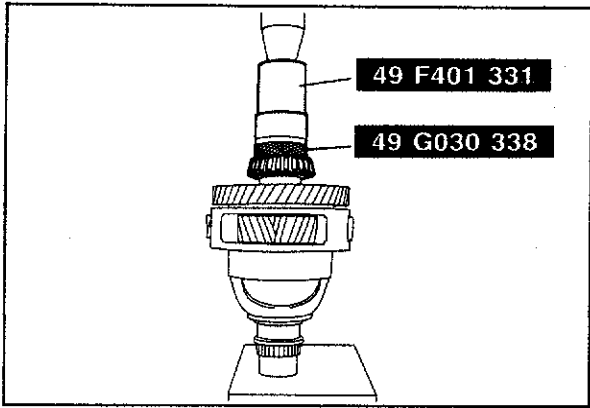

83U07C-079

5. Install the washer and the bearing inner race with the **SST**.

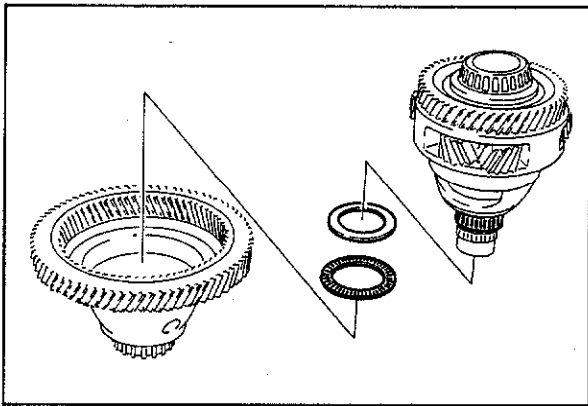

63G07C-149

6. Install the gear case needle bearings and differential lock thrust washer.

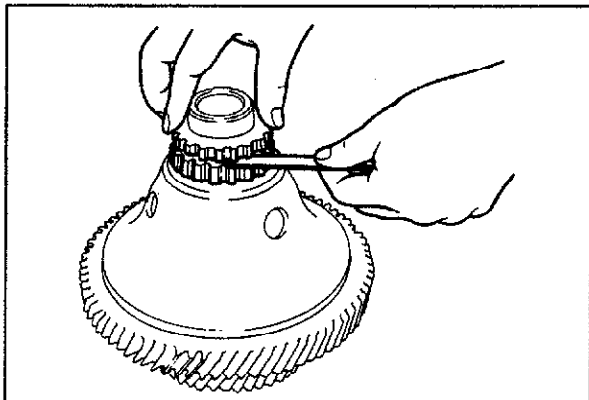

63G07C-150

7. Install the differential lock gear sleeve, differential lock hub and gear case needle bearing.  
8. Measure the clearance between the differential lock hub and the gear case needle bearing. If the clearance is not within specification, select the proper differential lock thrust washer.

**Standard: 0.15—0.30 mm (0.006—0.012 in)**

**Available washer thickness:**

**1.20 mm (0.047 in) 1.35 mm (0.053 in)**

**1.50 mm (0.059 in) 1.65 mm (0.065 in)**

**1.80 mm (0.071 in)**

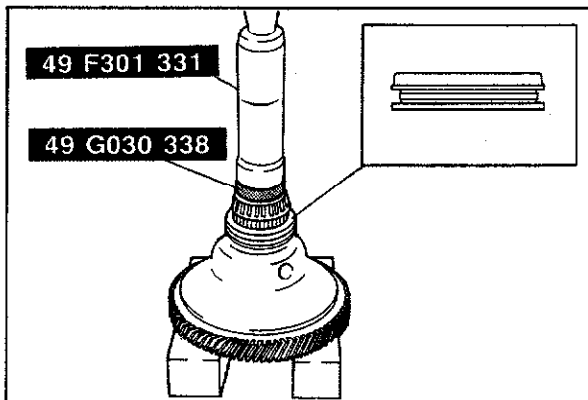

83U07C-015

9. Install the bearing inner race using a press and the **SST**.

## ASSEMBLY-STEP 2

Assemble in the sequence shown in the figure.

63G07C-307

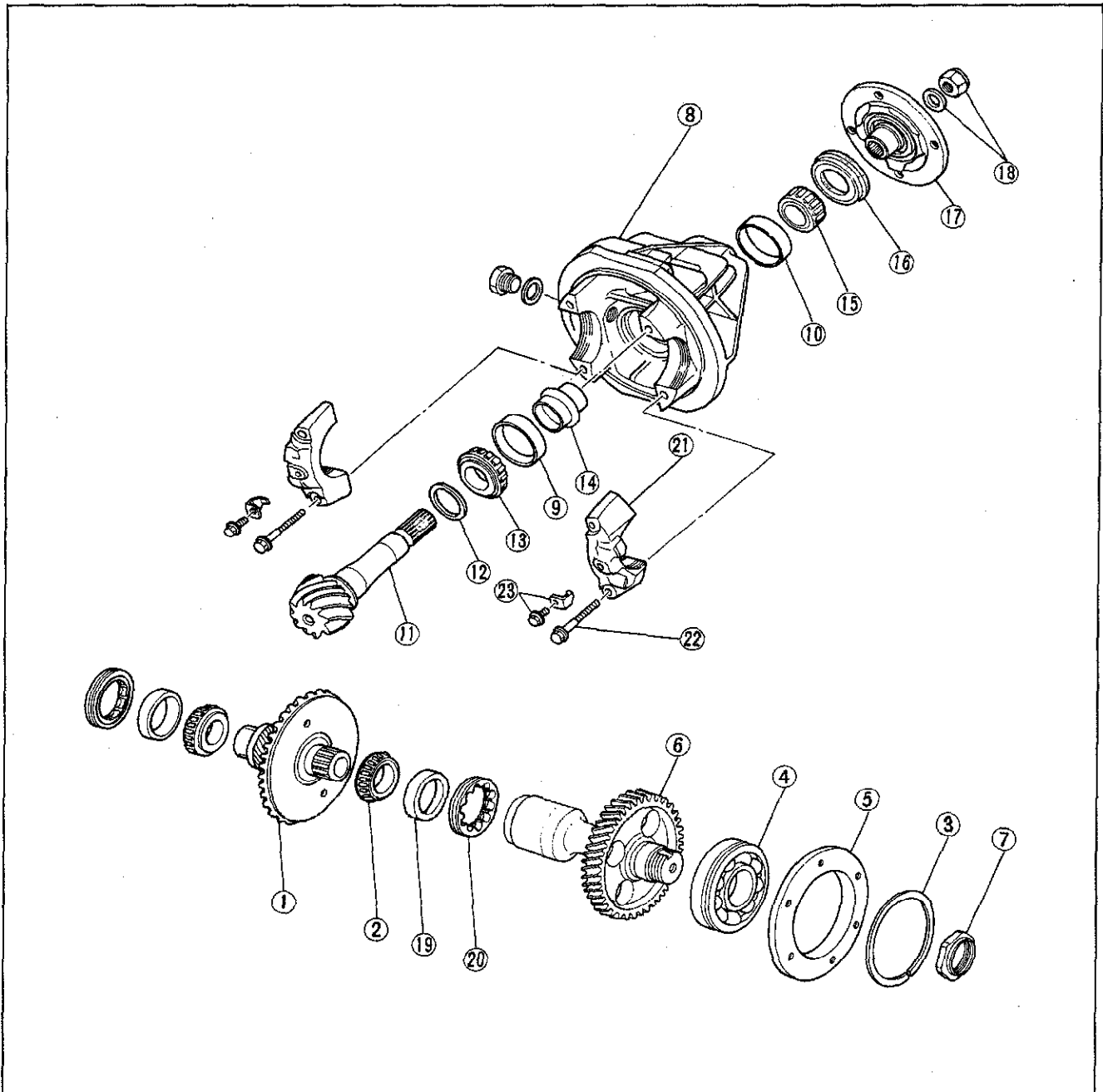

63G07C-152

- |                       |                        |                         |
|-----------------------|------------------------|-------------------------|
| 1. Differential gear  | 9. Bearing outer race  | 17. Companion flange    |
| 2. Bearing inner race | 10. Bearing outer race | 18. Washer and lock nut |
| 3. Retaining ring     | 11. Drive pinion       | 19. Bearing outer race  |
| 4. Bearing            | 12. Spacer             | 20. Adjustment screw    |
| 5. Side cover (B)     | 13. Bearing inner race | 21. Bearing cap         |
| 6. Idle gear          | 14. Collapsible spacer | 22. Bolt                |
| 7. Lock nut           | 15. Bearing inner race | 23. Lock plate and bolt |
| 8. Transfer carrier   | 16. Oil seal           |                         |

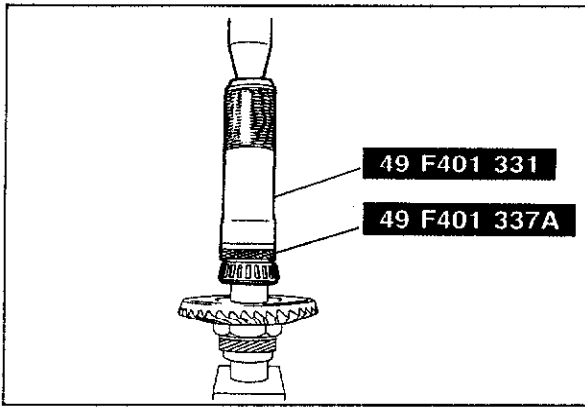

63G07C-153

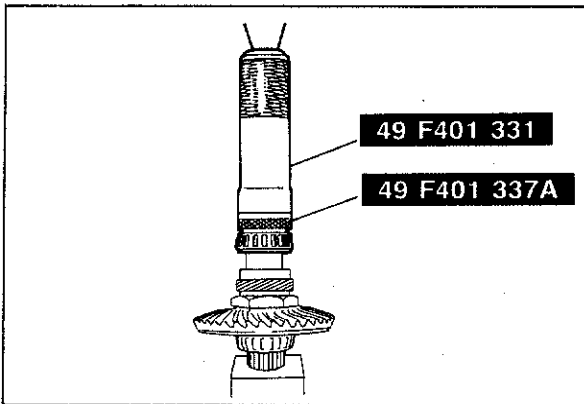

63G07C-154

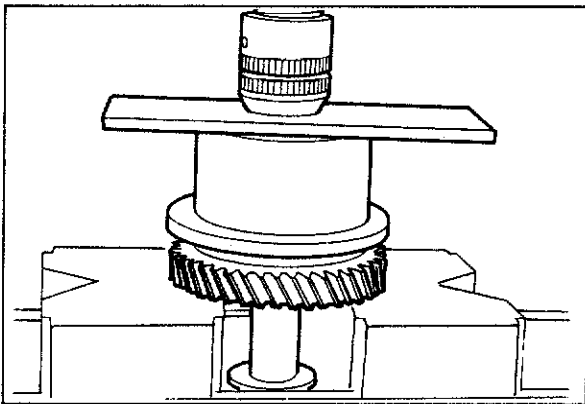

63G07C-155

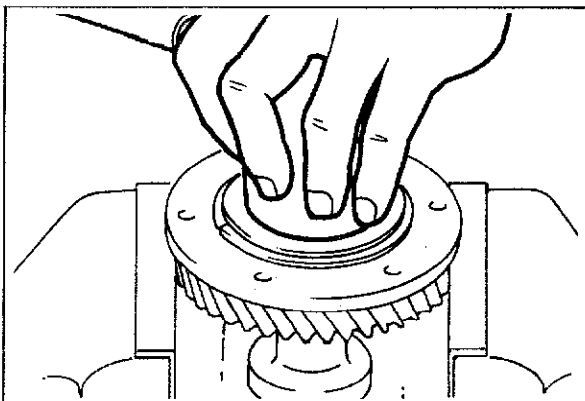

63G07C-156

## Bearing Inner Race (Differential gear)

1. Install the bearing inner race to the differential gear.

2. Install the bearing inner race to the differential gear.

## Idle Gear

1. Install the retaining ring to the bearing.
2. Install the side cover (B) and bearing to the idle gear using a press.

3. Use a new lock nut, tighten it and crimp it.

**Tightening torque: 127—206 N·m  
(13—21 m·kg, 94—152 ft·lb)**

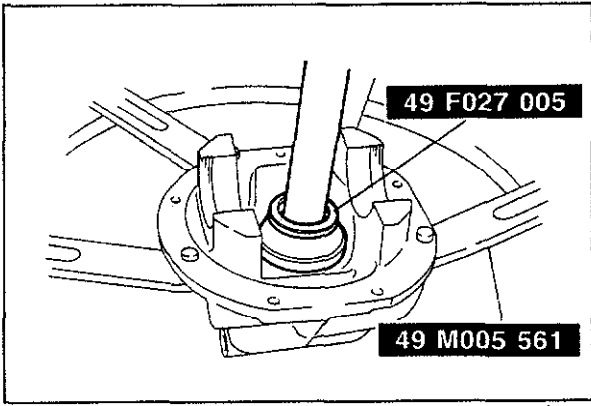

83U07C-080

**Adjustment of Pinion Height**

1. Mount the transfer carrier on the **SST**.
2. Install the bearing outer race with the **SST**.

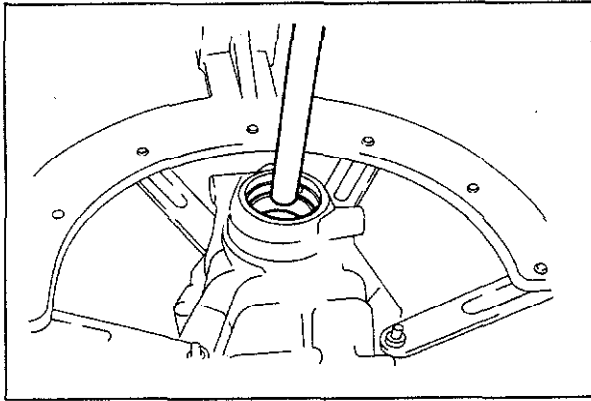

63G07C-158

3. Install the bearing outer race using a brass drift.

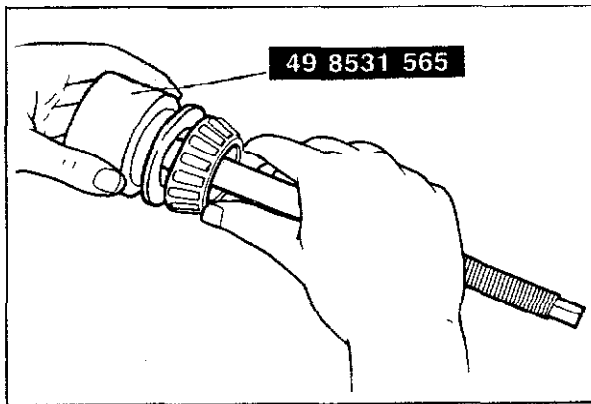

83U07C-081

4. Install the spacer and bearing inner race to the **SST**.

**Note**

**Use the spacer which was removed.**

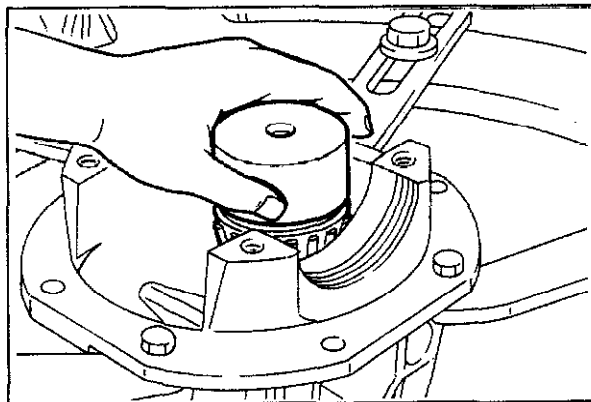

63G07C-160

5. Install the drive pinion model to transfer carrier.

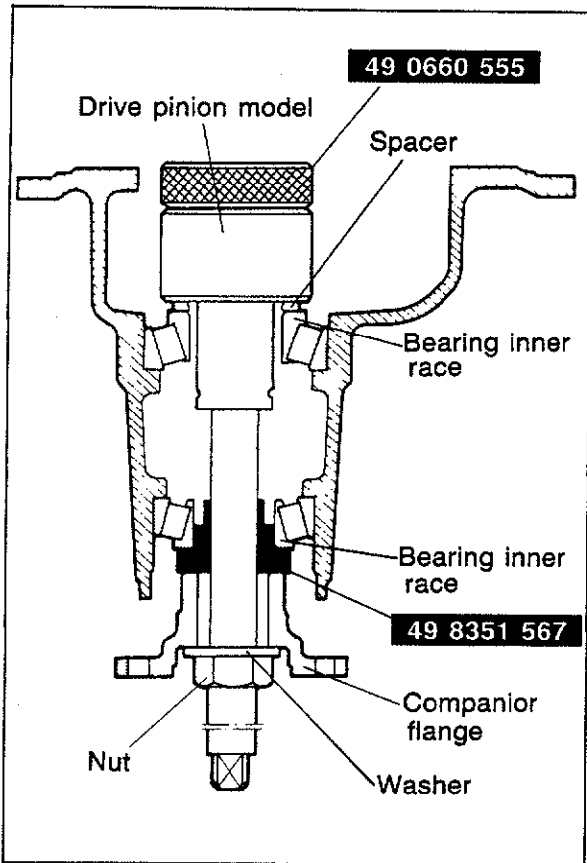

83U07C-082

6. Install the bearing inner race, companion flange, washer, nut and the **SST** to the drive pinion model.

**Note**

- a) Use the nut which was removed.
- b) Tighten the nut enough so that the drive pinion model can still be turned by hand.

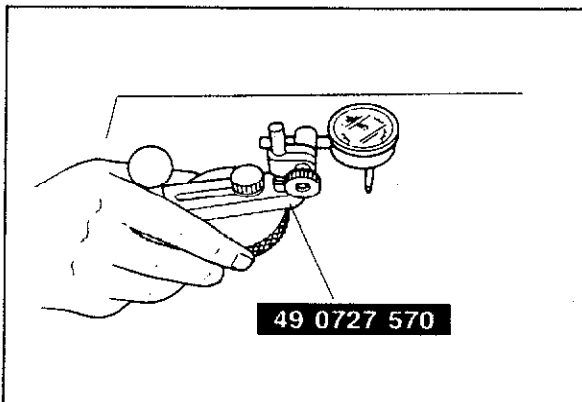

83U07C-083

7. Place the **SST** on the surface plate and set the dial indicator to "Zero".

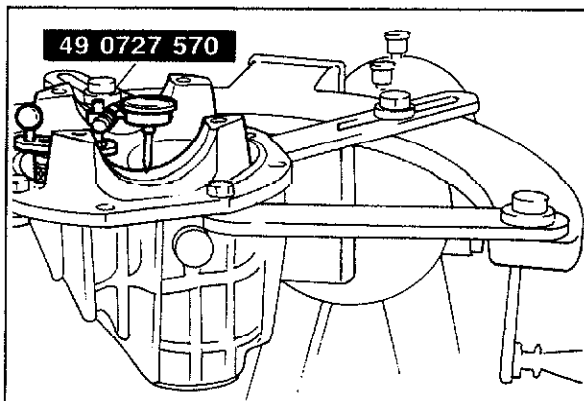

83U07C-084

8. Set the **SST** on top of the gauge block.
9. Place the measure probe of the dial indicator so that it contacts the area where the side bearing is installed in the carrier, and measure the lowest position. Measure both the left and the right sides.

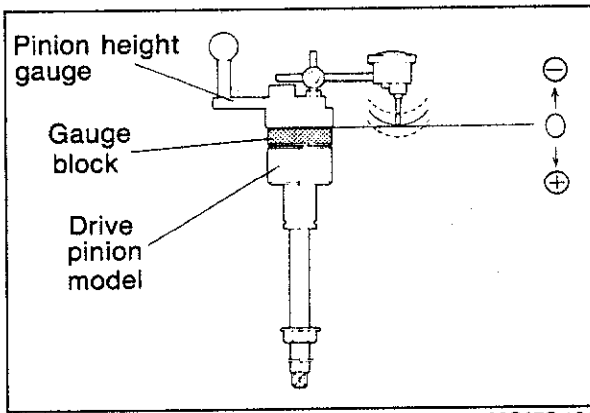

63G07C-164

10. Add the two (left and right) values obtained by the measurements taken in step 9, and then divide the total by 2.

**Specification: 0 mm (0 in)**

Mark	Thickness	Mark	Thickness
08	3.08 mm (0.1213 in)	29	3.29 mm (0.1295 in)
11	3.11 mm (0.1224 in)	32	3.32 mm (0.1307 in)
14	3.14 mm (0.1236 in)	35	3.35 mm (0.1319 in)
17	3.17 mm (0.1248 in)	38	3.38 mm (0.1331 in)
20	3.20 mm (0.1260 in)	41	3.41 mm (0.1343 in)
23	3.23 mm (0.1271 in)	44	3.44 mm (0.1354 in)
26	3.26 mm (0.1283 in)	47	3.47 mm (0.1366 in)

63G07B-165

11. If it is not to the specification, adjust the pinion height by selection of a spacer.

**Note**

**The spacer thicknesses are available in 0.03 mm (0.001 in) steps. Select the spacer thickness that is closest to that necessary.**

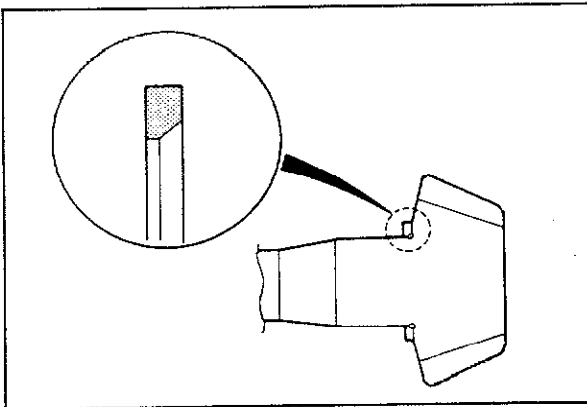

63G07C-166

12. Install the spacer to the drive pinion.

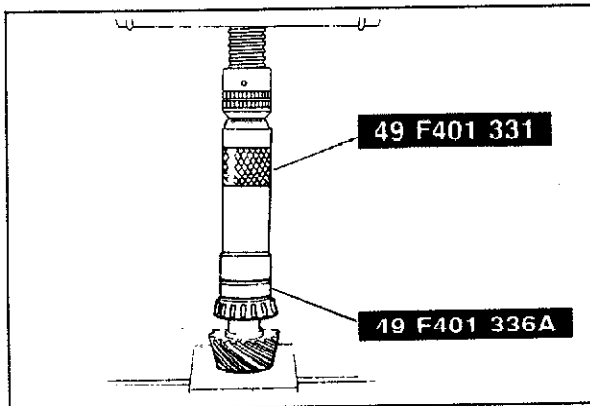

83U07C-085

13. Press the bearing inner race on with the **SST**.

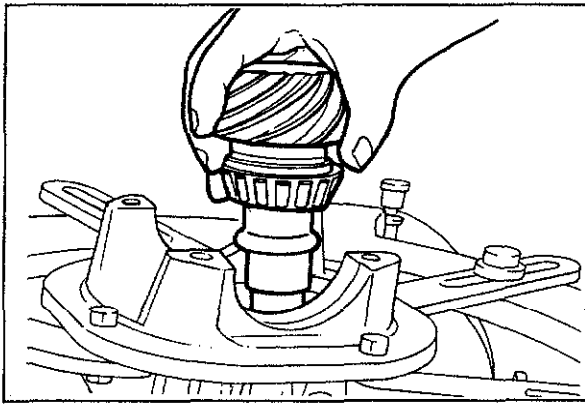

63G07C-168

## Adjustment of Drive Pinion Preload

1. Install the collapsible spacer.
2. Install the drive pinion assembly

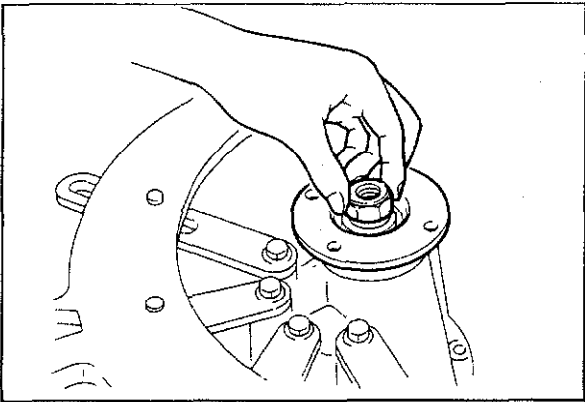

63G07C-169

3. Install the bearing inner race and companion flange and tighten the lock nut.

### Note

**Do not install the oil seal.**

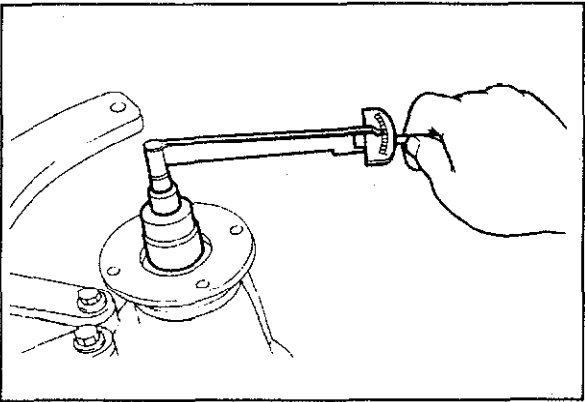

63G07C-170

4. Turn the companion flange by hand to seat the bearing.
5. Measure the drive pinion preload.

**Preload: 1—1.6 N·m**

**(10—16 cm·kg, 8.7—13.9 in·lb)**

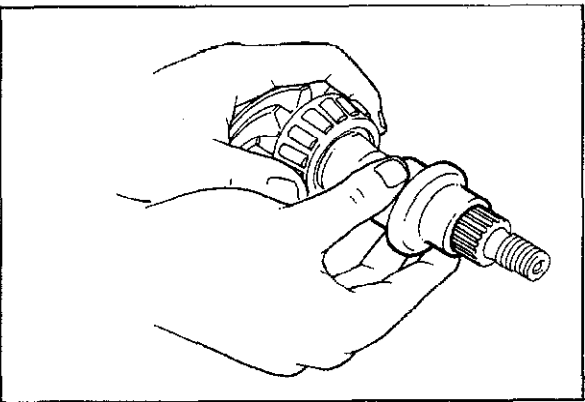

63G07C-171

6. If the specified preload can not be obtained, replace the collapsible spacer with a new one and check again.

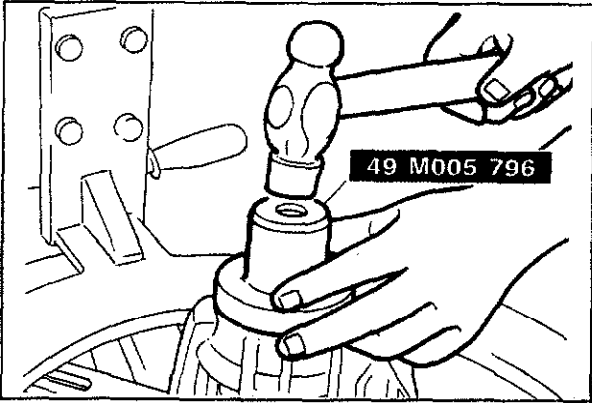

83U07C-086

7. Remove the nut, washer and companion flange.
8. Tap the oil seal into the differential carrier with the **SST**.

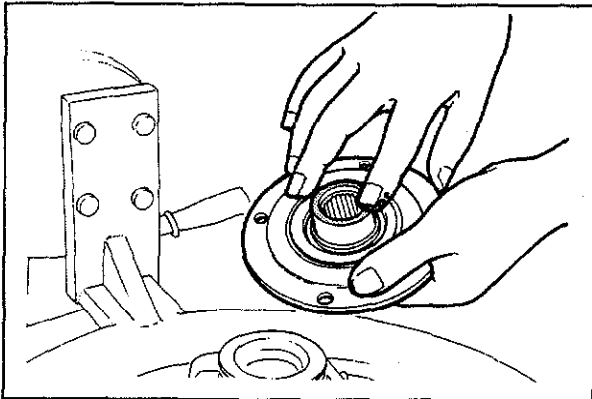

63G07C-173

9. Coat companion flange with oil.
10. Install the companion flange and washer.

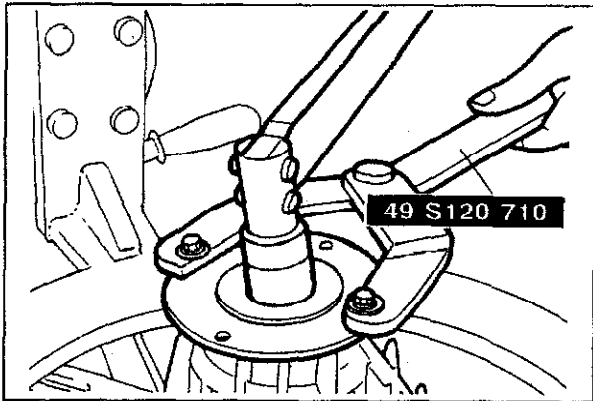

83U07C-087

11. Install and tighten a new lock nut with the **SST**.

**Tightening torque: 118—177 N·m  
(12—18 m·kg, 87—130 ft·lb)**

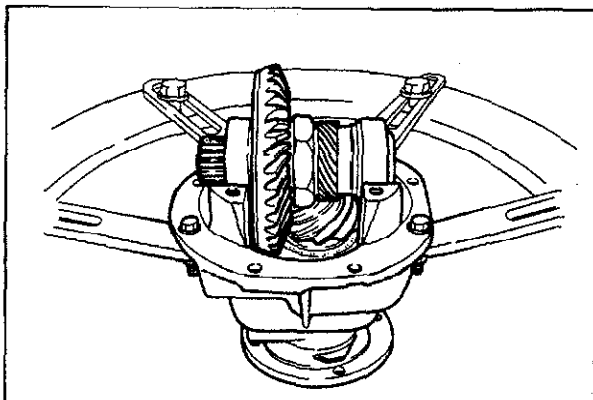

63G07C-175

**Adjustment of Backlash**

1. Position the idle gear assembly in the carrier.



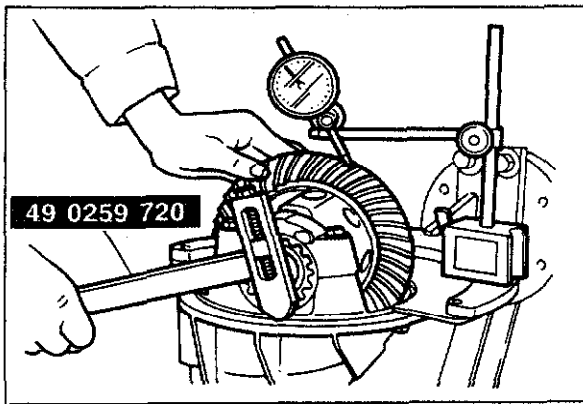

63G07C-176

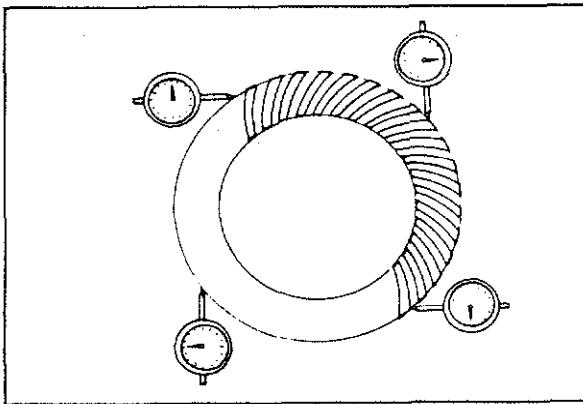

83U07C-088

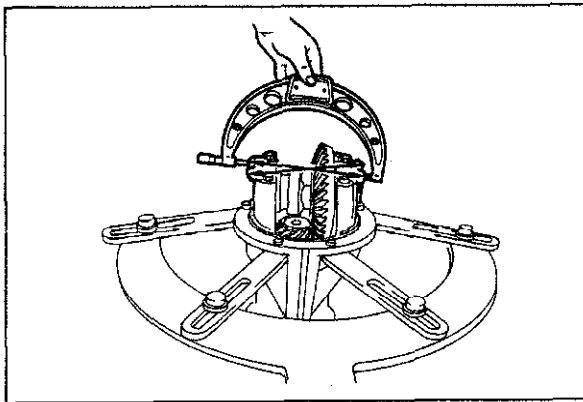

63G07C-178

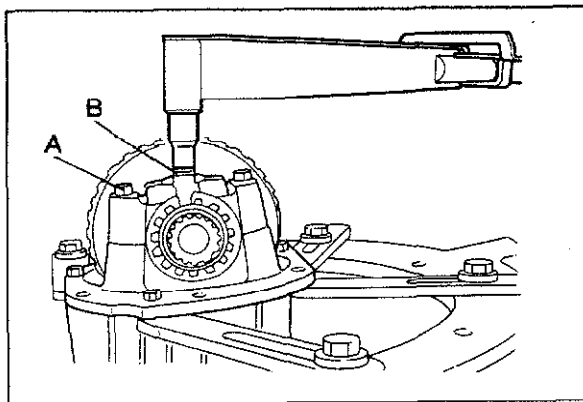

83U07C-089

2. Install the differential bearing caps making sure that the matching marks on the caps correspond with those on the carrier.
3. Loosely tighten the bearing cap bolts on each side and adjust the backlash.
4. Mark the ring gear at four points at approx. 90° intervals on the ring gear and mount a dial indicator to the carrier so that the feeler comes in contact at a 90° angle with one of the ring gear teeth.

5. Turn both adjustment screws equally until the backlash is within specifications with the **SST**.

**Standard backlash: 0.09—0.11 mm  
(0.0035—0.0043 in)**

6. After adjusting the backlash, tighten the adjustment screws equally until the distance between the pilot sections on the bearing caps becomes as specified distance.

**Specification:  
144.17—144.24 mm (5.6760—5.6787 in)**

**Note**  
When adjusting the differential bearing preload, care must be taken not to affect the backlash of the drive pinion gear and ring gear.

7. Tighten the bearing cap bolts to the specified torque.

**Tightening torque:**  
A 37—52 Nm (3.8—5.3 m-kg, 27—38 ft-lb)  
B 18—26 Nm (1.8—2.6 m-kg, 13—19 ft-lb)

8. Install the lock plates on the bearing caps to prevent the adjustment screws from loosening.

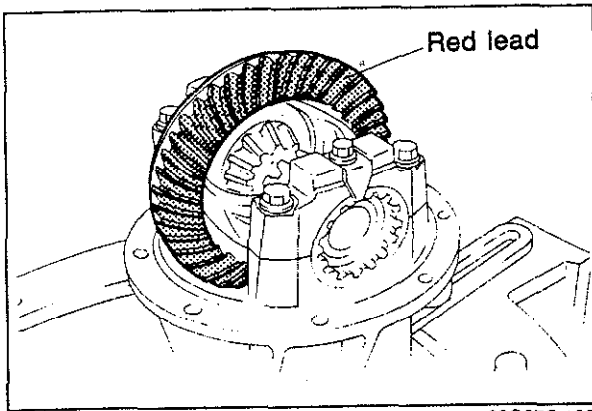

63G07C-180

- Inspection and Adjustment of Tooth Contact**
1. Coat both surfaces of 6—8 teeth of the ring gear uniformly with a thin coating of red lead.
  2. While moving the ring gear back and forth by hand, rotate the drive pinion several times and check the tooth contact.

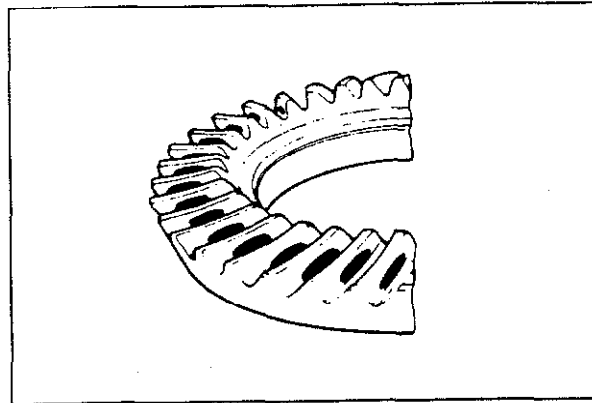

63G07C-181

3. If the tooth contact is correct, wipe off the red lead.

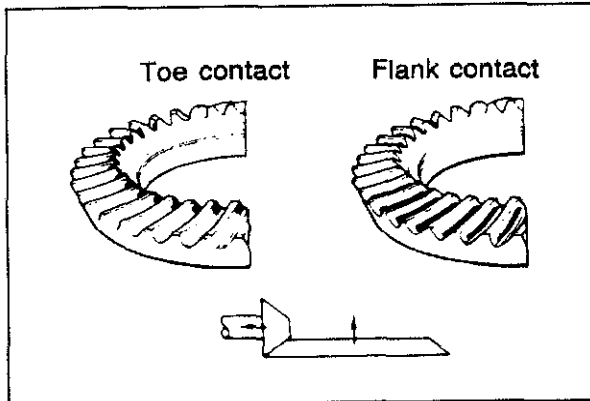

63G07C-182

4. If it is not correct, adjust the pinion height, and then adjust the backlash.

(1) Toe and flank contact

Replace the spacer with a thinner one, and move the drive pinion outward.

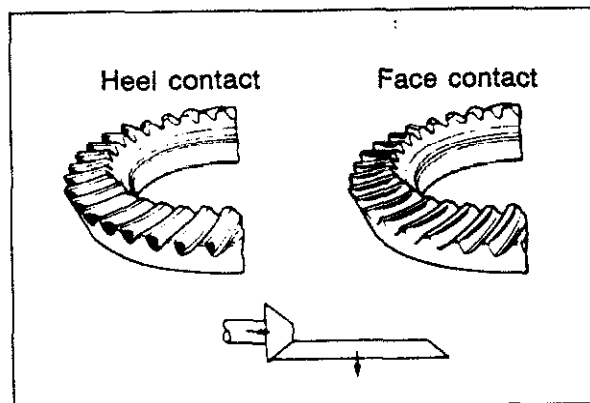

63G07C-183

(2) Heel and face contact

Replace the spacer with a thicker one, and bring the drive pinion closer in.

## ASSEMBLY-STEP 3

Assemble in the sequence shown in the figure.

63G07C-308

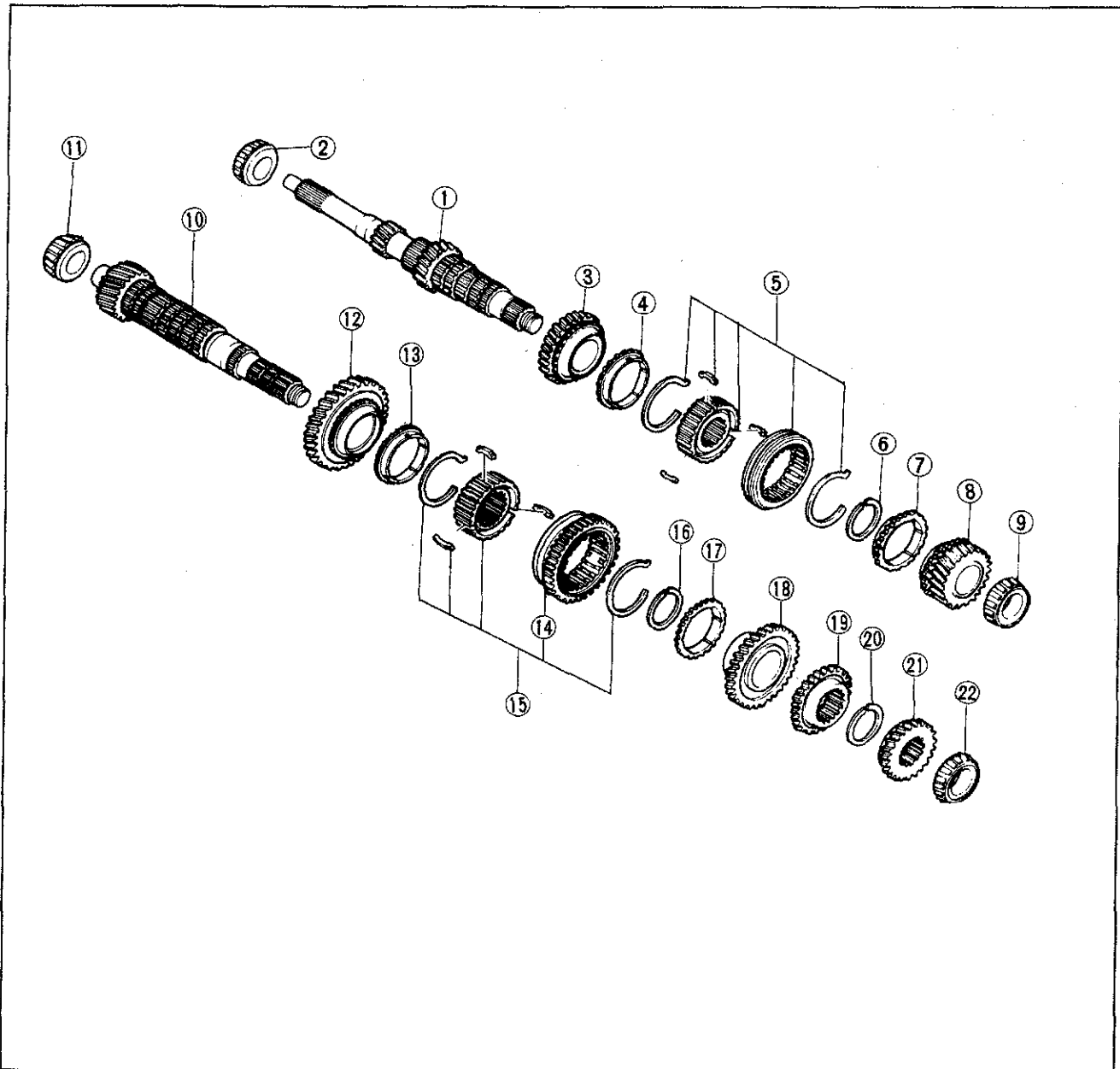

63G07C-184

- |                          |                         |
|--------------------------|-------------------------|
| 1. Primary shaft gear    | 12. 1st gear            |
| 2. Bearing inner race    | 13. Synchronizer ring   |
| 3. 3rd gear              | 14. Reverse gear        |
| 4. Synchronizer ring     | 15. Clutch hub assembly |
| 5. Clutch hub assembly   | 16. Retaining ring      |
| 6. Retaining ring        | 17. Synchronizer ring   |
| 7. Synchronizer ring     | 18. 2nd gear            |
| 8. 4th gear              | 19. Secondary 3rd gear  |
| 9. Bearing inner race    | 20. Retaining ring      |
| 10. Secondary shaft gear | 21. Secondary 4th gear  |
| 11. Bearing inner race   | 22. Bearing inner race  |

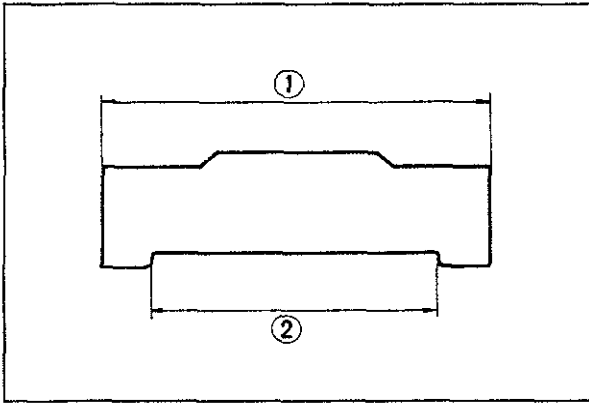

63G07C-185

## Synchronizer Key

### Note

There are two (2) types of synchronizer key.

Standard dimension:

mm (in)

	①	②
1st and 2nd	19 (0.7480)	14.2 (0.5591)
3rd and 4th 5th and rev.	17 (0.6693)	12.2 (0.4803)

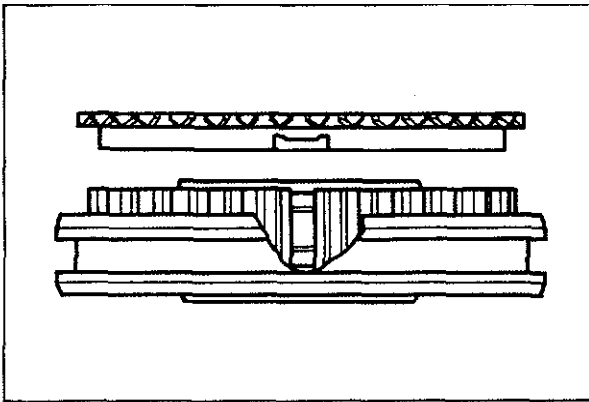

7707A-050

### Note

Align the synchronizer ring groove and clutch hub key when installing.

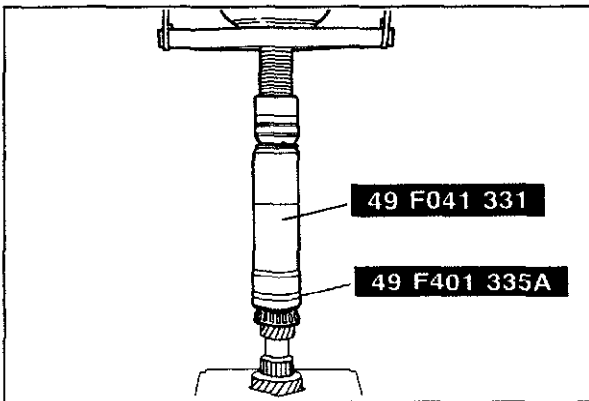

83U07C-090

## (PRIMARY SHAFT GEAR)

### Bearing Inner Race

1. Install the bearing inner race with the **SST**.

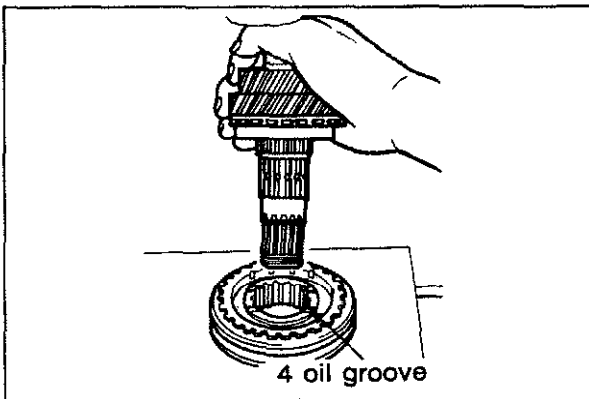

63G07C-187

## Clutch Hub Assembly (3rd-4th gear)

1. Install 3rd gear and synchronizer ring.  
2. Set the clutch hub assembly as shown in the figure.

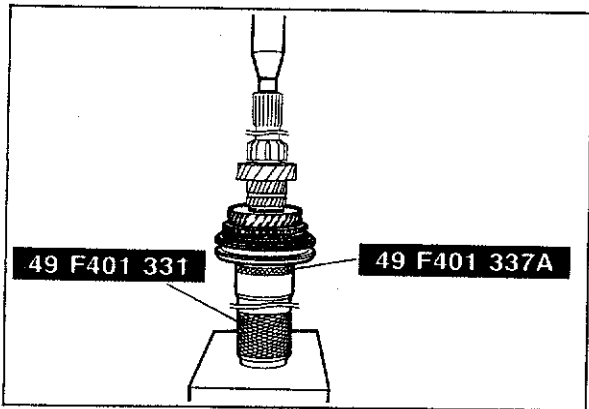

83U07C-091

3. Install the clutch hub assembly with the **SST**.

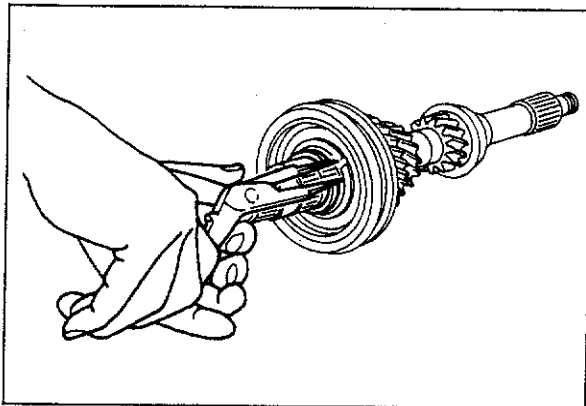

63G07C-189

4. Install the retaining ring.

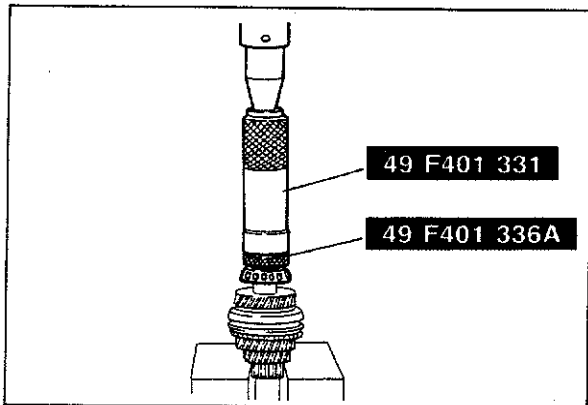

83U07C-092

### 4th Gear

1. Install the 4th gear and synchronizer ring.
2. Install the bearing inner race with the **SST**.

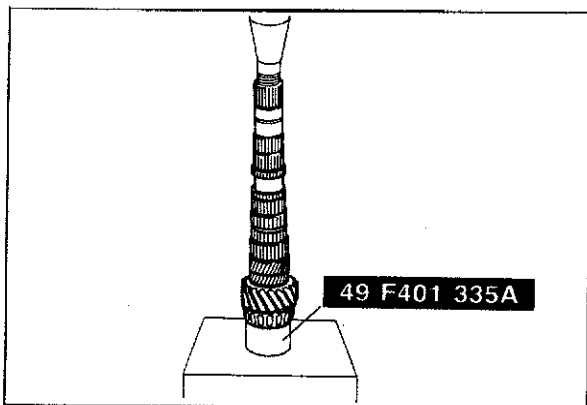

83U07C-093

### (SECONDARY SHAFT GEAR)

#### Bearing Inner Race

Install the bearing inner race with the **SST**.

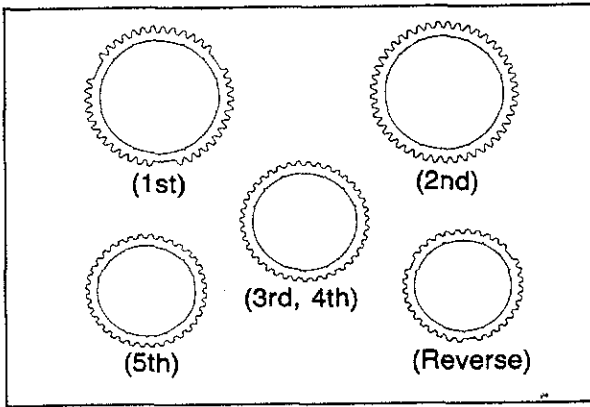

83U07C-094

**Note**  
The styles and size of the synchronizer rings are different as shown in the illustration.

1. Install the 1st gear and synchronizer ring.
2. Install the clutch hub assembly with the **SST**.

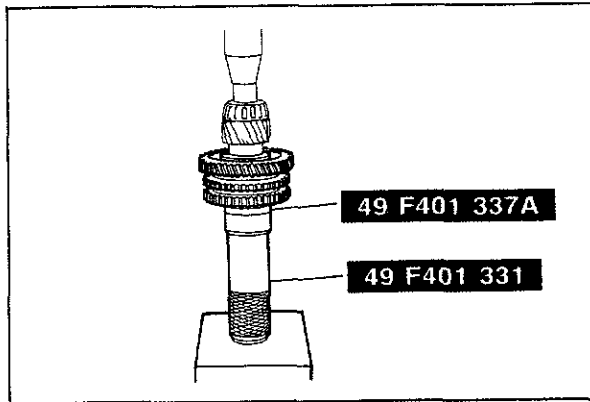

83U07C-095

3. Install the retaining ring.

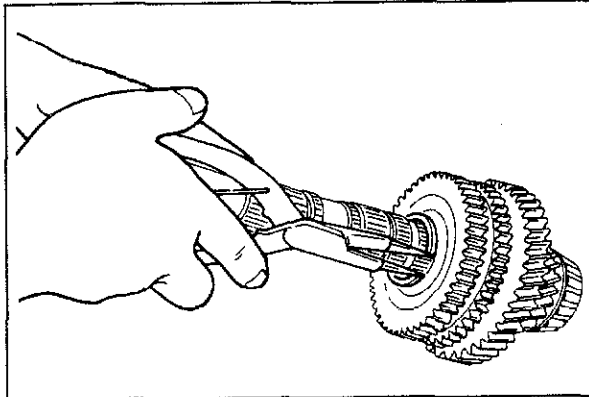

63G07C-194

### 2nd Gear

1. Install the synchronizer ring and 2nd gear.
2. Install the secondary 3rd gear.

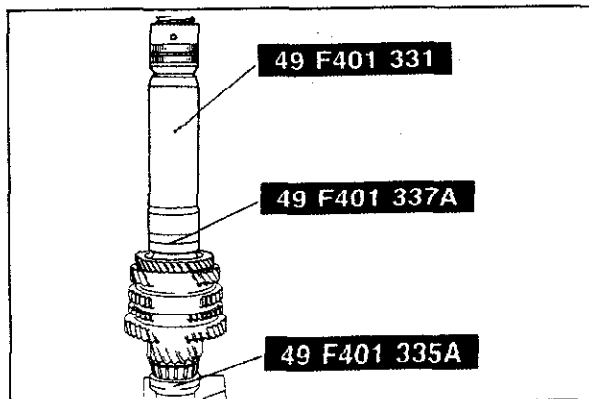

63G07C-195

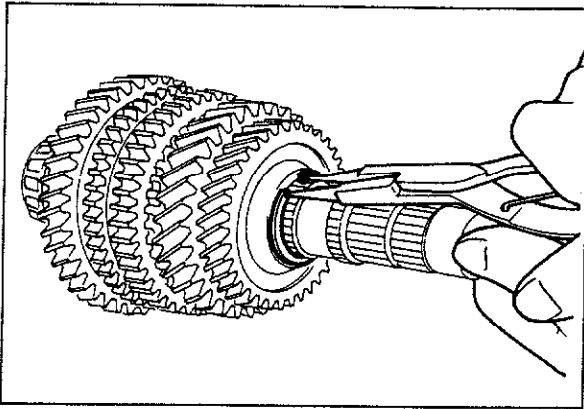

63G07C-196

3. Install the retaining ring.

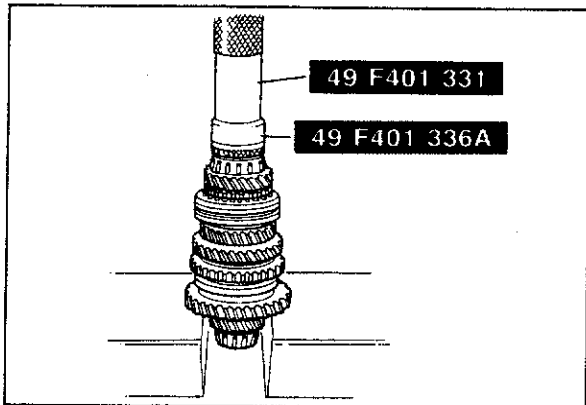

63G07C-197

### Secondary 4th Gear

1. Install the secondary 4th gear.
2. Install the bearing inner race.

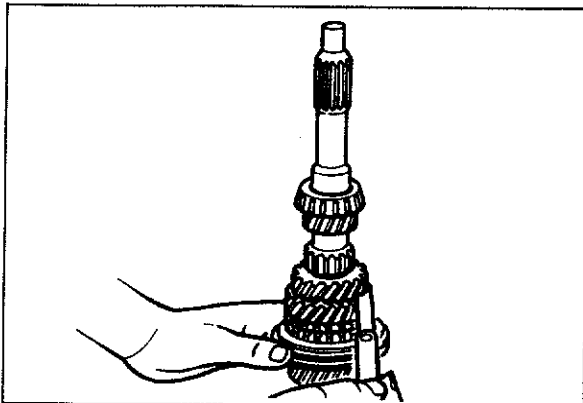

63G07C-198

### Thrust Clearance of 3rd Gear

Measure the clearance between the 3rd gear and the primary shaft gear.

**Standard: 0.050—0.200 mm (0.002—0.008 in)**  
**Maximum: 0.250 mm (0.039 in)**

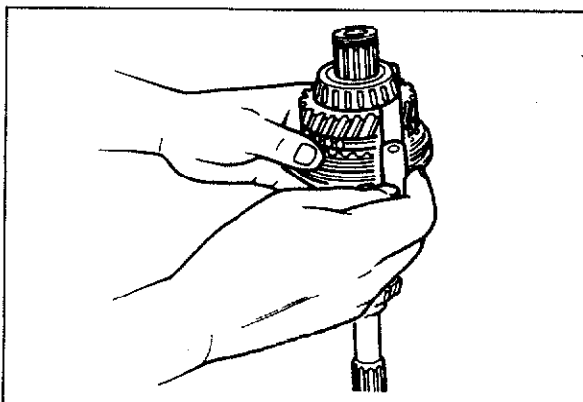

63G07C-199

### Thrust Clearance of 4th Gear

Measure the clearance between the 4th gear and the bearing inner race.

**Standard: 0.165—0.365 mm (0.006—0.014 in)**  
**Maximum: 0.415 mm (0.0163 in)**

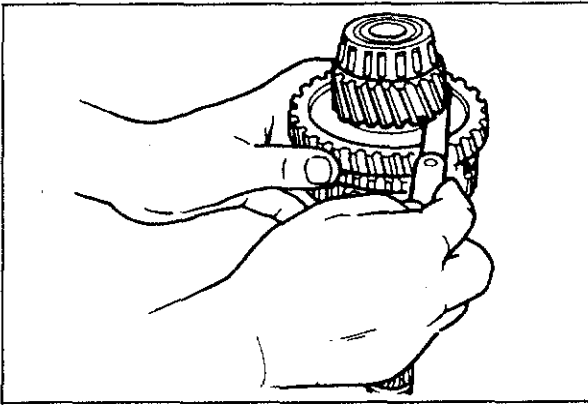

63G07C-200

**Thrust Clearance of 1st Gear**

Measure the clearance between the 1st gear and the differential drive gear on the secondary shaft.

**Standard: 0.050—0.280 mm (0.002—0.011 in)**

**Maximum: 0.330 mm (0.013 in)**

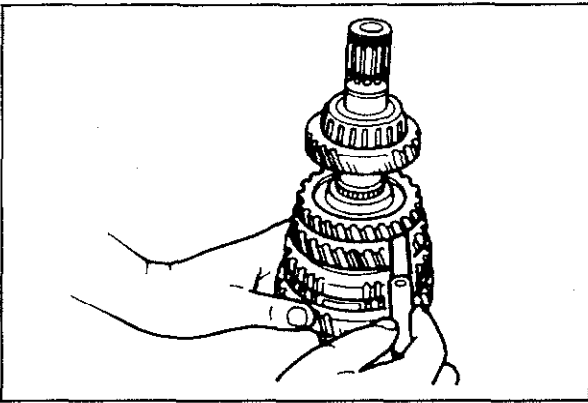

63G07C-201

**Thrust Clearance of 2nd Gear**

Measure the clearance between the 2nd gear and the secondary 3rd gear.

**Standard: 0.175—0.455 mm (0.007—0.018 in)**

**Maximum: 0.505 mm (0.0199 in)**

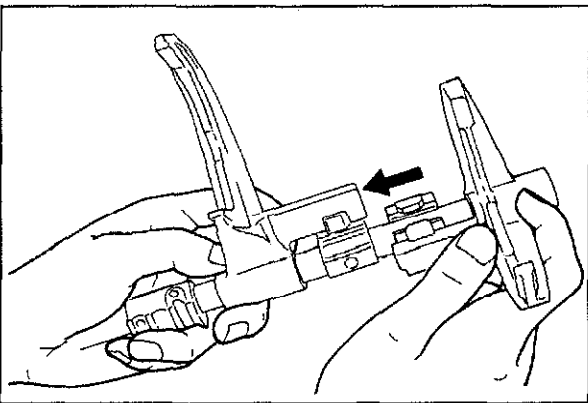

63G07C-202

**Shift Fork**

Install both shift forks and the interlock sleeve as in the figure.



## ASSEMBLY-STEP 4

Assemble in the sequence shown in the figure.

63G07C-309

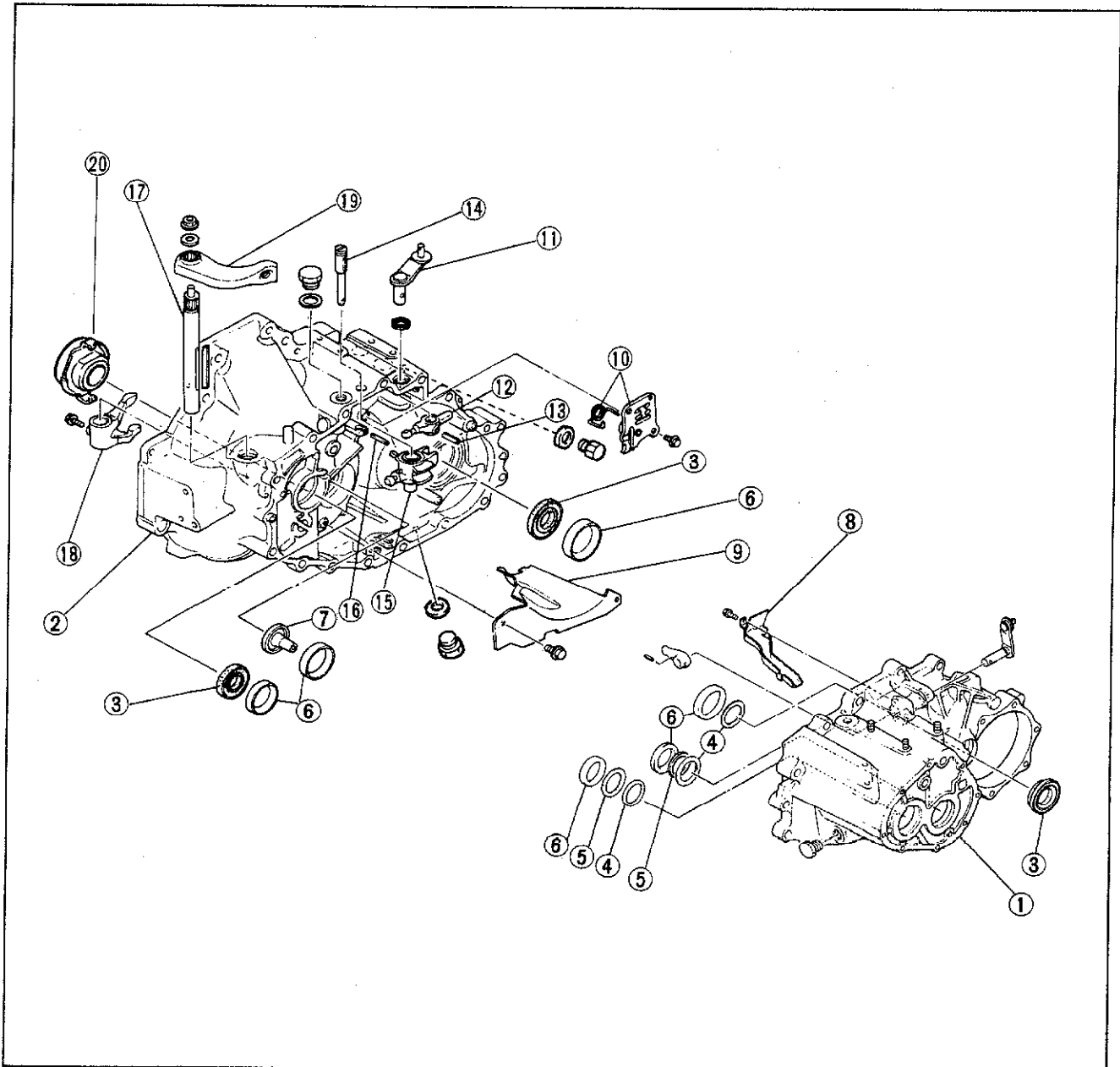

83U07C-016

- |                         |                           |
|-------------------------|---------------------------|
| 1. Transaxle case       | 11. Select lever          |
| 2. Clutch housing       | 12. Inner shift lever     |
| 3. Oil seal             | 13. Spring pin            |
| 4. Washer(s)            | 14. Crank lever shaft     |
| 5. Diaphragm spring     | 15. Crank lever           |
| 6. Bearing outer race   | 16. Spring pin            |
| 7. Funnel               | 17. Clutch release shaft  |
| 8. Oil passage          | 18. Clutch release fork   |
| 9. Baffle plate         | 19. Clutch lever          |
| 10. Base plate assembly | 20. Clutch release collar |

## Bearing preload

Adjust the bearing preload by selecting and installing the proper adjust shim (s).

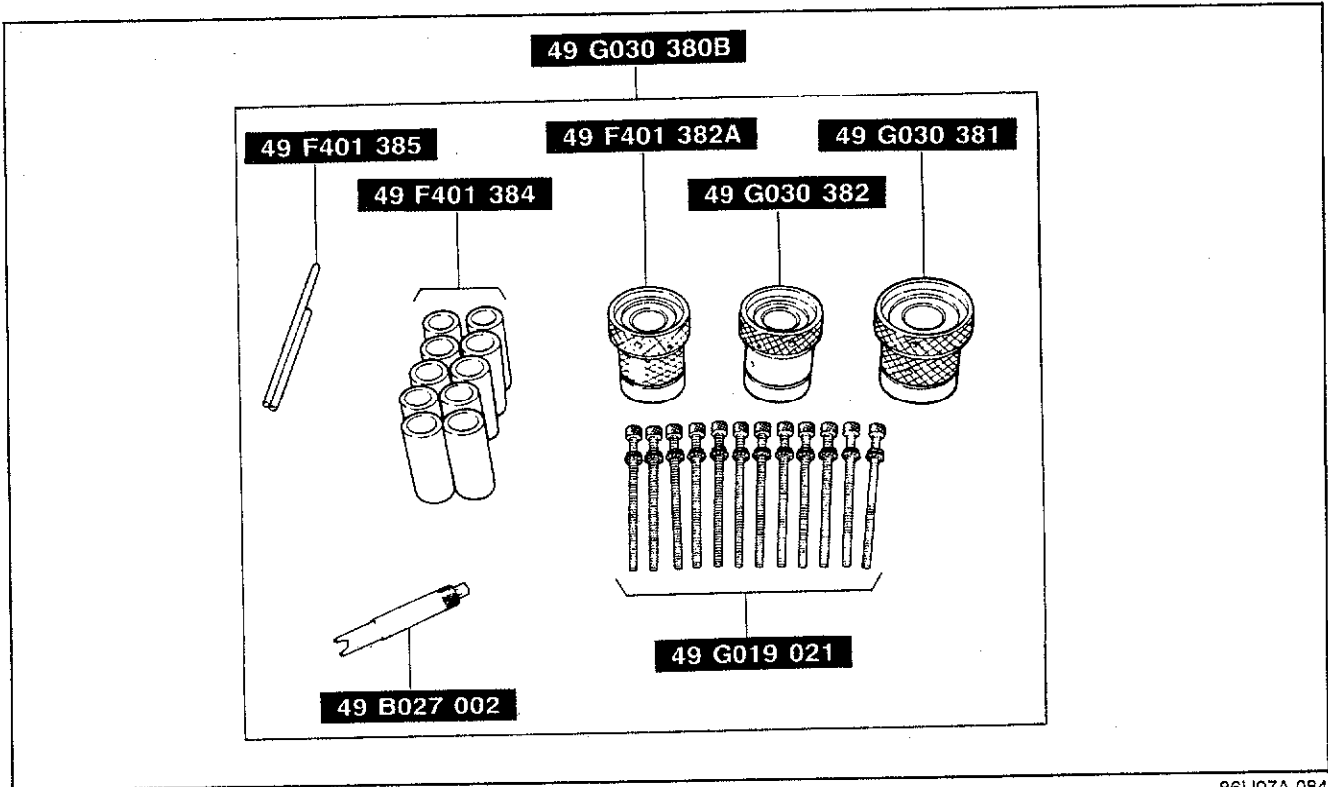

86U07A-084

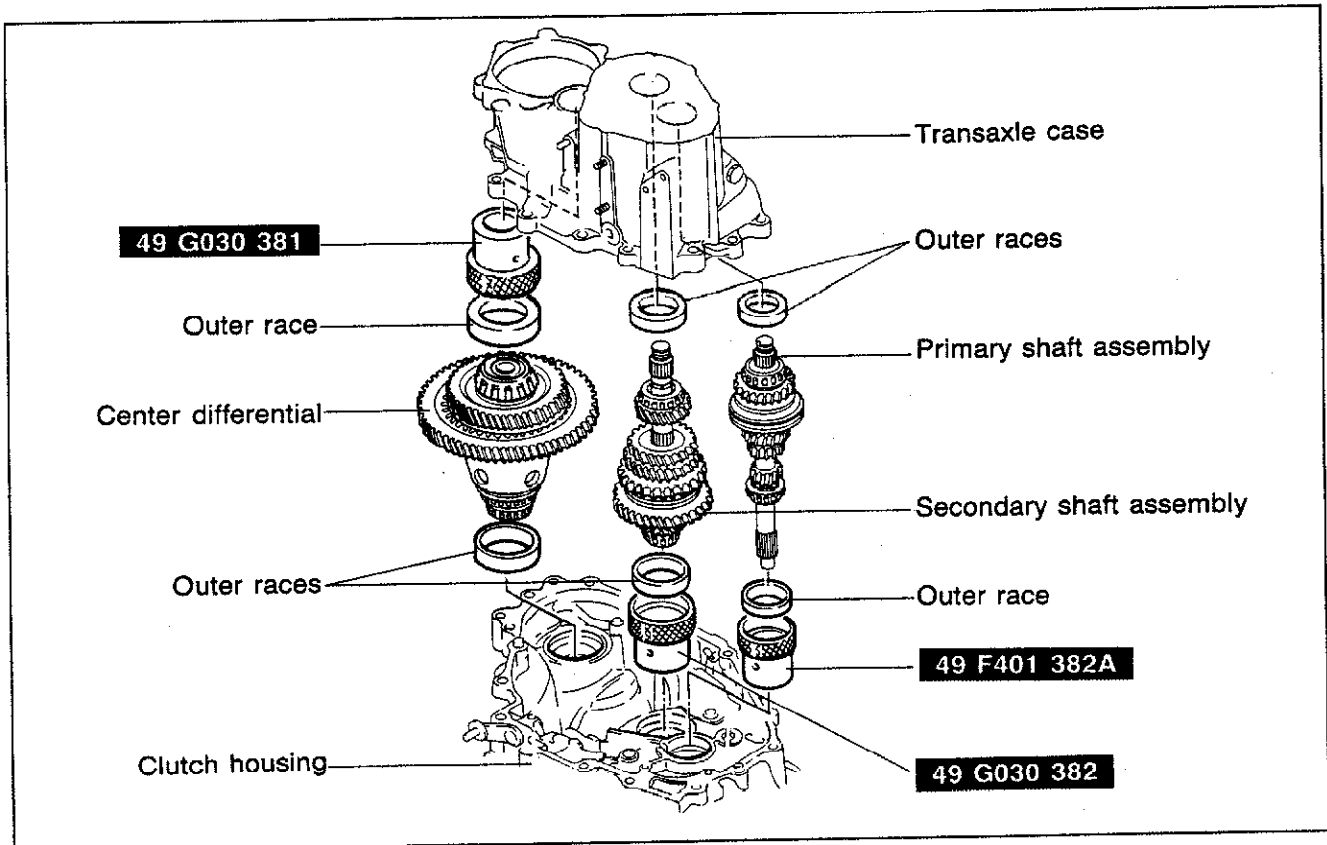

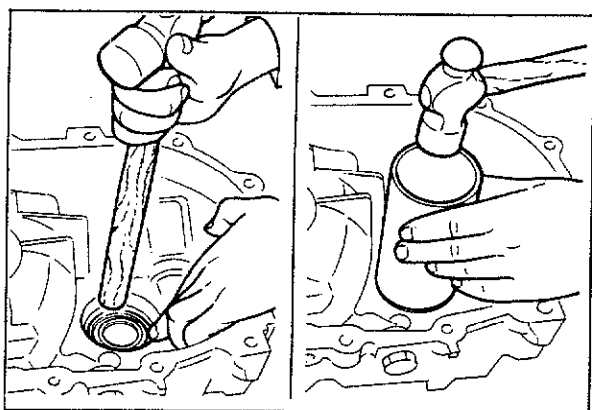

83U07C-096

1. Install the primary and secondary shaft bearing outer races into the transaxle case (shims removed).
2. After mounting the clutch housing onto the transaxle hanger, tap in the differential bearing outer race with a hammer handle until it is flush with the end of the clutch housing.

Next, position a piece of pipe against the outer race and tap in with a hammer until it contacts the clutch housing.

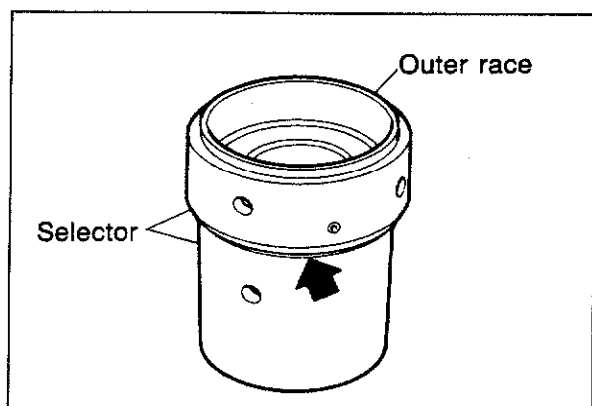

83U07C-097

### Primary and Secondary Shaft Gear

1. As shown in the figure, put the outer races into the **SST**.

#### Note

Turn the selector to eliminate the gap indicated by the arrow in the figure.

2. Set the **SST** in place.
3. Mount the primary and secondary shaft gear assemblies to the **SST**.

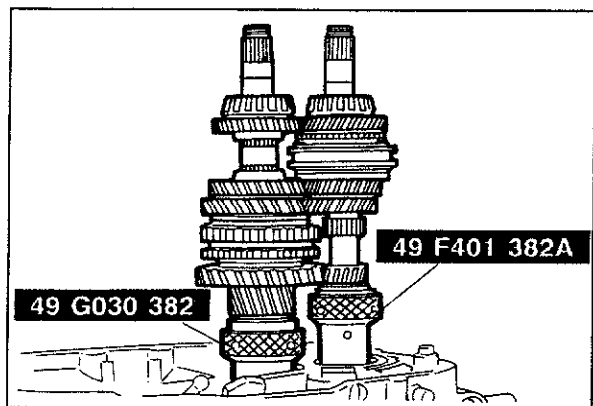

83U07C-098

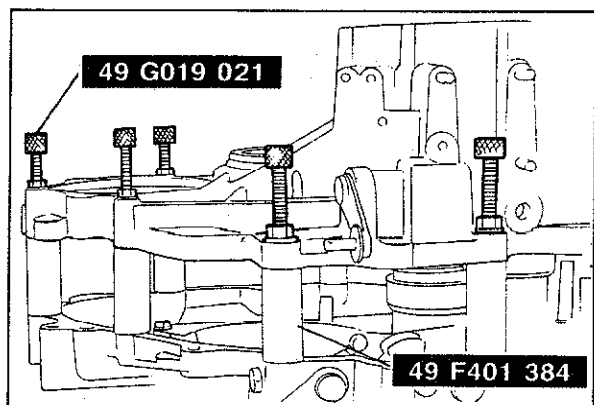

83U07C-099

4. Set the **SST** between the transaxle case and the clutch housing, and install the **SST**, and tighten to the specified torque.

#### Tightening torque:

37—52 N·m (3.8—5.3 m·kg, 27—38 ft·lb)

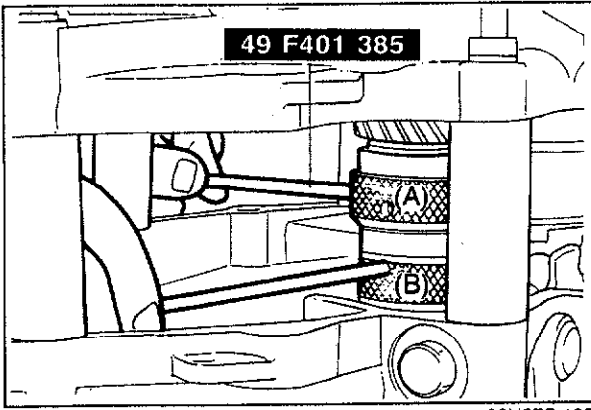

83U07C-100

- To seat the bearings, mount the **SST** on parts (A) and (B) of the selector, and then turn the selector so the gap is widened. Move the bar by hand until the selector can no longer be turned, and then turn it in the reverse direction until the gap is eliminated.

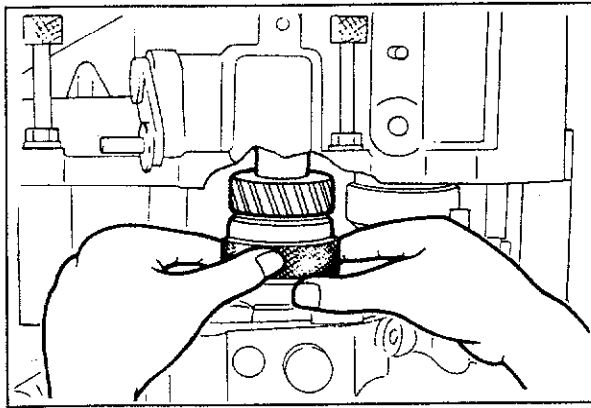

63G07C-210

- Manually expand the selector for both shafts until the selector no longer turns.

**Note**

**Make sure that each shaft turns smoothly.**

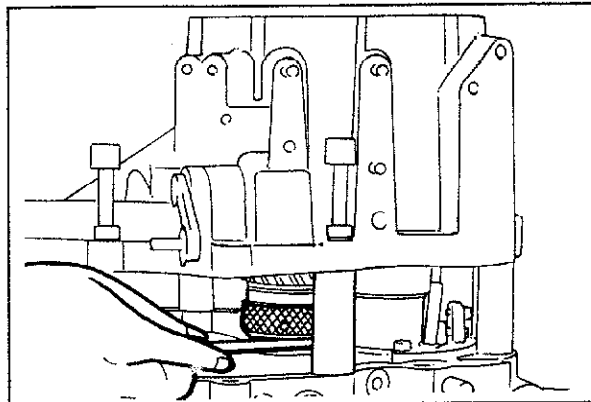

63G07C-211

- Use a thickness gauge to measure the gap of the selector for both gears.

**Note**

**Measure the gap around the entire circumference of the selector.**

- Select an appropriate adjustment shim.
  - The shim to be used for the primary shaft gear should be selected by referring to the table and selecting the shim which is nearest (on the thin side) to the value obtained, by subtracting the thickness of the diaphragm spring which goes between the shim and the race, from the measured value of the gap in the selector.

**Example: 0.94 mm (0.0370 in)**

$$0.94 \text{ mm (0.0370 in)} - 0.70 \text{ mm (0.0276 in)} \\ \text{[Diaphragm spring]}$$

$$= 0.24 \text{ mm (0.009 in)}$$

**So the nearest shim (on thin side) to 0.24 mm (0.009 in) is 0.20 mm (0.008 in).**

Thickness mm (in)
0.20 (0.008)
0.25 (0.010)
0.30 (0.012)
0.35 (0.014)
0.40 (0.016)
0.45 (0.018)
0.50 (0.020)
0.55 (0.022)
0.60 (0.024)
0.65 (0.026)
0.70 (0.028)

83U07C-018

- (2) The shim to be used for the secondary shaft gear should be selected by referring to the table and selecting the shim which is nearest (on the thick side) to the value obtained, by subtracting the thickness of the diaphragm spring which goes between the shim and the race, from the measured value of the gap in the selector.

**Example: 0.94 mm (0.0370 in)**  
**0.94 mm (0.0370 in) — 0.70 mm (0.0276 in)**  
**[Diaphragm spring]**  
**= 0.24 mm (0.009 in)**  
**So the nearest shim (on thick side) to 0.24 mm (0.009 in) is 0.25 mm (0.010 in).**

**Note**  
**The number of shims used must not be more than two.**

83U07C-043

9. Remove the **SST** and then remove the transaxle case, shaft gears and selectors.  
10. Remove the bearing outer races for both shafts from the transaxle case.

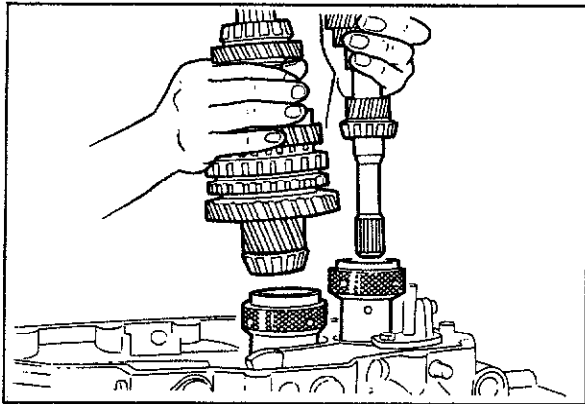

83U07C-101

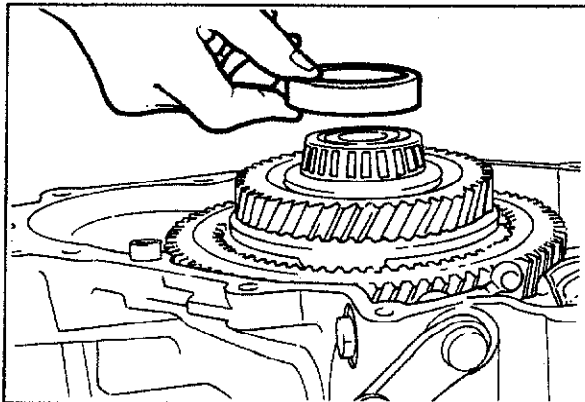

63G07C-214

## Center Differential

1. Install the center differential and bearing outer race.

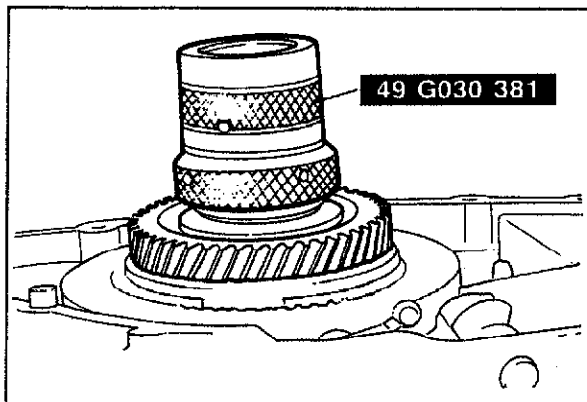

83U07C-102

2. Set the **SST** in place.

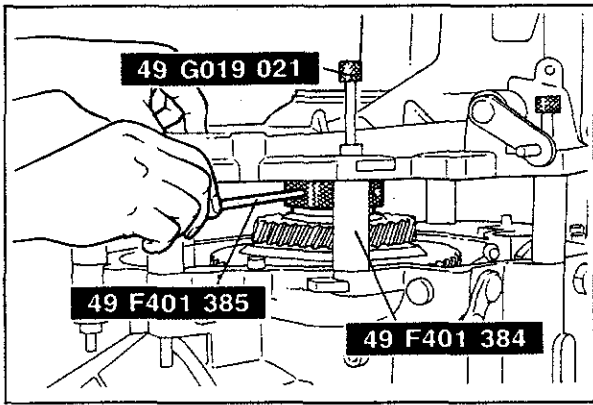

83U07C-103

3. Set the **SST** between the transaxle case and the clutch housing, and install the **SST**, and tighten to the specified torque.

**Tightening torque:**

**37—52 N·m (3.8—5.3 m·kg, 27—38 ft·lb)**

4. To seat bearings turn the **SST** so the gap is widened.

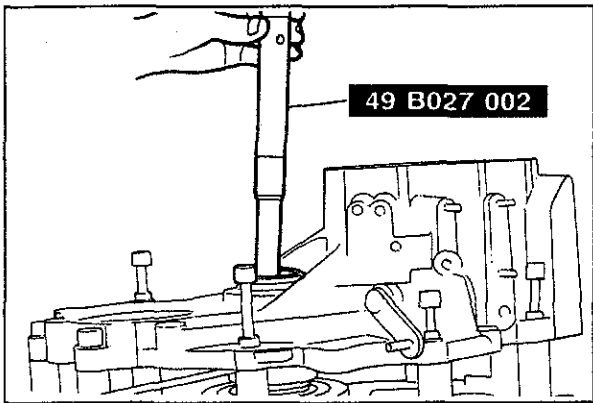

83U07C-104

5. Insert the **SST**.

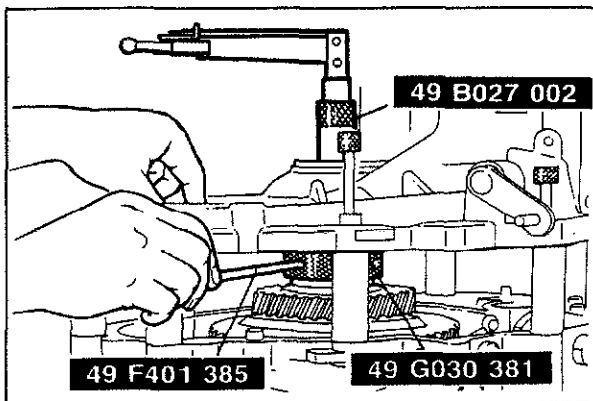

83U07C-105

6. Expand the **SST** until preload specification is obtained.

**Preload: 0.3—1.2 N·m**

**(3—12 cm·kg, 2.6—10.4 in·lb)**

7. Use a thickness gauge to measure the gap in the selector for both gears.

**Note**

**Measure the gap around the entire circumference of the selector.**

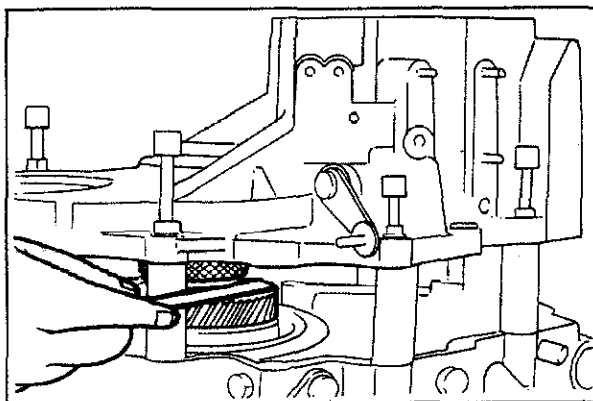

63G07C-219

Thickness mm (in)
0.1 (0.004)
0.2 (0.008)
0.3 (0.012)
0.4 (0.016)
0.5 (0.020)
0.6 (0.024)
0.7 (0.028)
0.8 (0.032)
0.9 (0.036)
1.0 (0.040)
1.1 (0.044)
1.2 (0.048)

83U07C-106

8. Select an appropriate adjustment shim to be used for the differential. It should be selected by referring to the table and selecting the shim which is nearest (on thick side) to the largest measured value of the gap in the selector.

**Example: 0.54 mm (0.021 in)**

**So the nearest shim (on thick side) to 0.54 mm (0.021 in) is 0.6 mm (0.014 in).**

**Note**

**The number of shims to be used must not be more than three.**

9. Remove the **SST** and then remove transaxle case.
10. Remove the selector, bearing outer race and front and center differential.

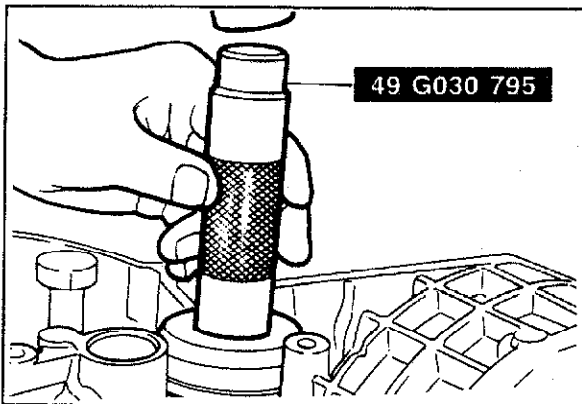

83U07C-019

**Oil Seal**

Tap the new oil seals into the transaxle case and clutch housing with the **SST**.

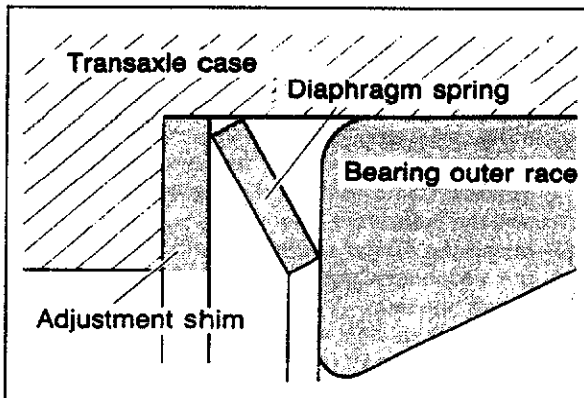

83U07C-020

**Bearing Outer Race**

1. Install the selected adjustment shims and the diaphragm springs into the transaxle case.

**Note**

**Install the diaphragm spring as shown in the figure.**

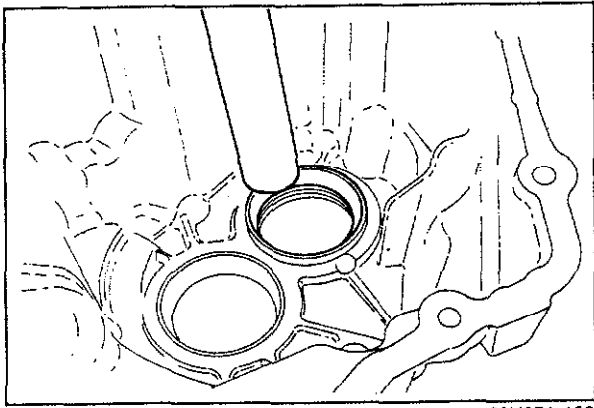

63U07A-120

2. Install the bearing outer races into the transaxle case and clutch housing.

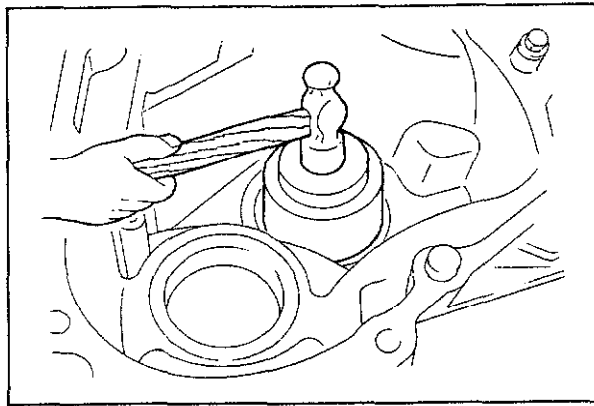

63U07A-121

3. Use a suitable pipe and a hammer to tap the outer races in until they are seated.

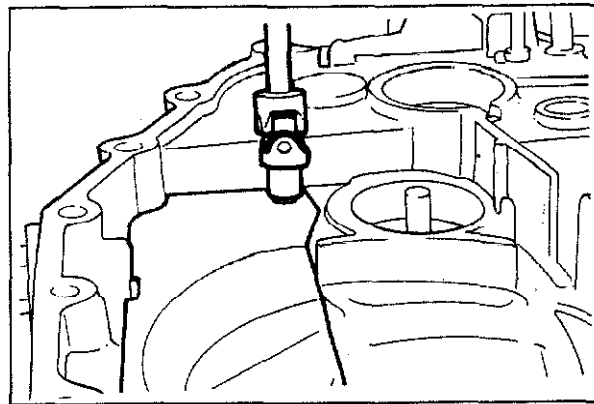

63G07C-223

**Baffle Plate and Oil Passage**

1. Install the baffle plate and oil passage.

**Tightening torque: 7.9—10.8 N·m  
(0.8—1.1 m·kg 5.79—7.96 ft·lb)**

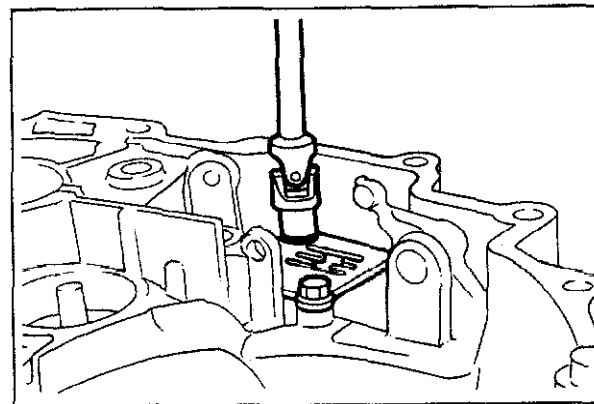

63G07C-224

**Base Plate Assembly**

1. Install the base plate spring and base plate.

**Tightening torque: 18.6—25.5 N·m  
(1.9—2.6 m·kg 13.74—18.81 ft·lb)**



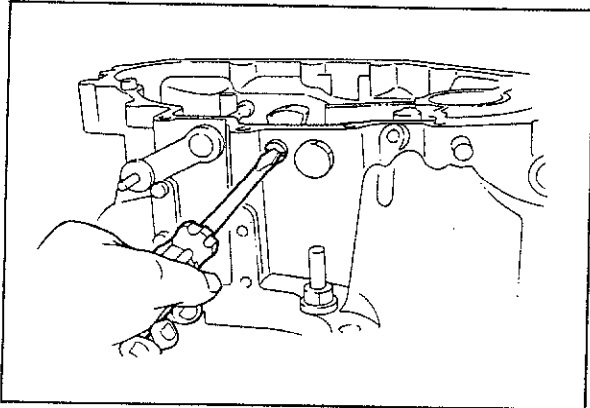

63G07C-225

2. Install the crank lever shaft and crank lever.
3. Install the spring pin.

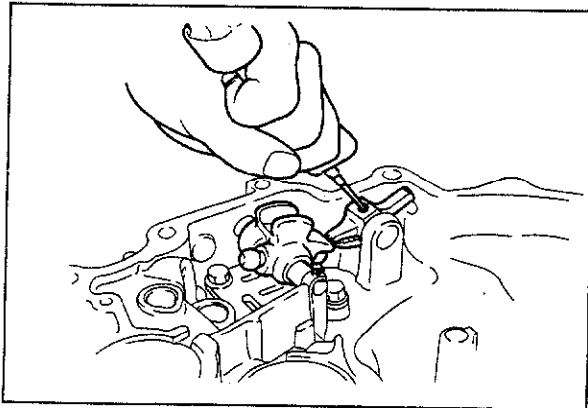

63G07C-226

4. Install the inner shift lever to shift lever assembly and then install them to crank lever assembly.
5. Install the spring pin.

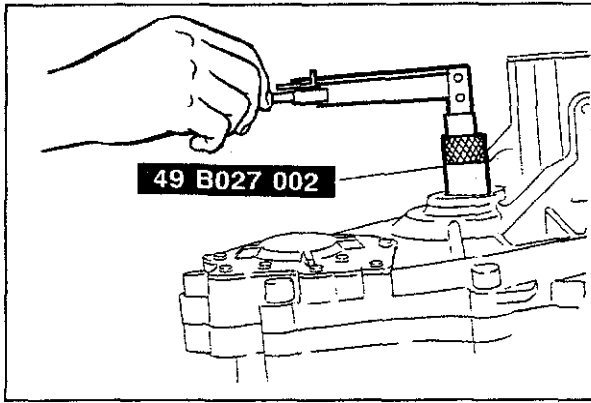

83U07C-021

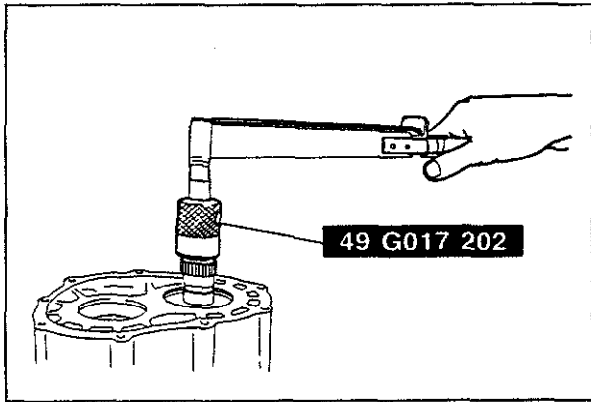

83U07C-022

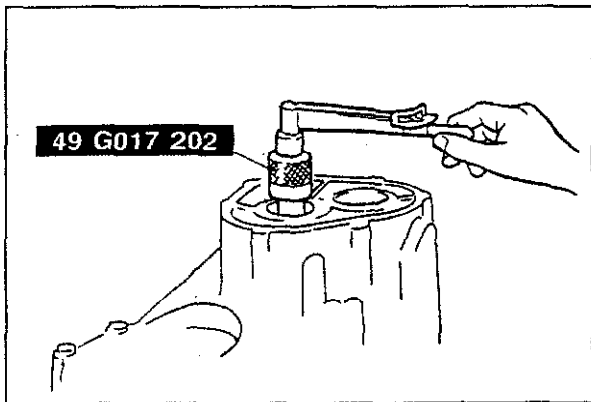

83U07C-023

**Bearing Preload**

Check the shaft gears and the differential bearing preload.

**Note**

- a) Check that the correct adjust shims were selected.
- b) If the bearing preload is not within specification, adjust again.

1. Set the primary shaft gear and the center differential assembly into the clutch housing.
2. Install the transaxle case, and tighten to the specified torque.

**Tightening torque: 37—52 N·m  
(3.8—5.3 m·kg, 27—38 ft·lb)**

3. Connect the **SST** and install it through the driveshaft hole.
4. Hook a spring scale to the attachment and measure the preload.

**Note**

**Extend the handle fully and hook the pull scale to the end of the handle.**

**Preload: 1.4—2.0 N·m  
(14—20 cm·kg, 12.2—17.5 in·lb)**

5. Remove the **SST**.
6. Connect the **SST** to the primary shaft gear.
7. Check the primary shaft preload.

**Preload: 0.10—0.25 N·m  
(1.0—2.5 cm·kg, 0.87—2.18 in·lb)**

8. Remove the **SST**, transaxle case, primary shaft gear and center differential assembly.
9. Install the secondary shaft gear and transaxle case then tighten to the specified torque.

**Tightening torque: 37—52 N·m  
(3.8—5.3 m·kg, 27—38 ft·lb)**

10. Check the secondary shaft preload with the **SST**.

**Preload: 0.2—0.4 N·m  
(2.0—4.0 cm·kg, 1.7—3.5 in·lb)**

11. Remove the **SST**, transaxle case and secondary shaft gear.

## ASSEMBLY-STEP 5

Assemble in the sequence shown in the figure.

63G07C-227

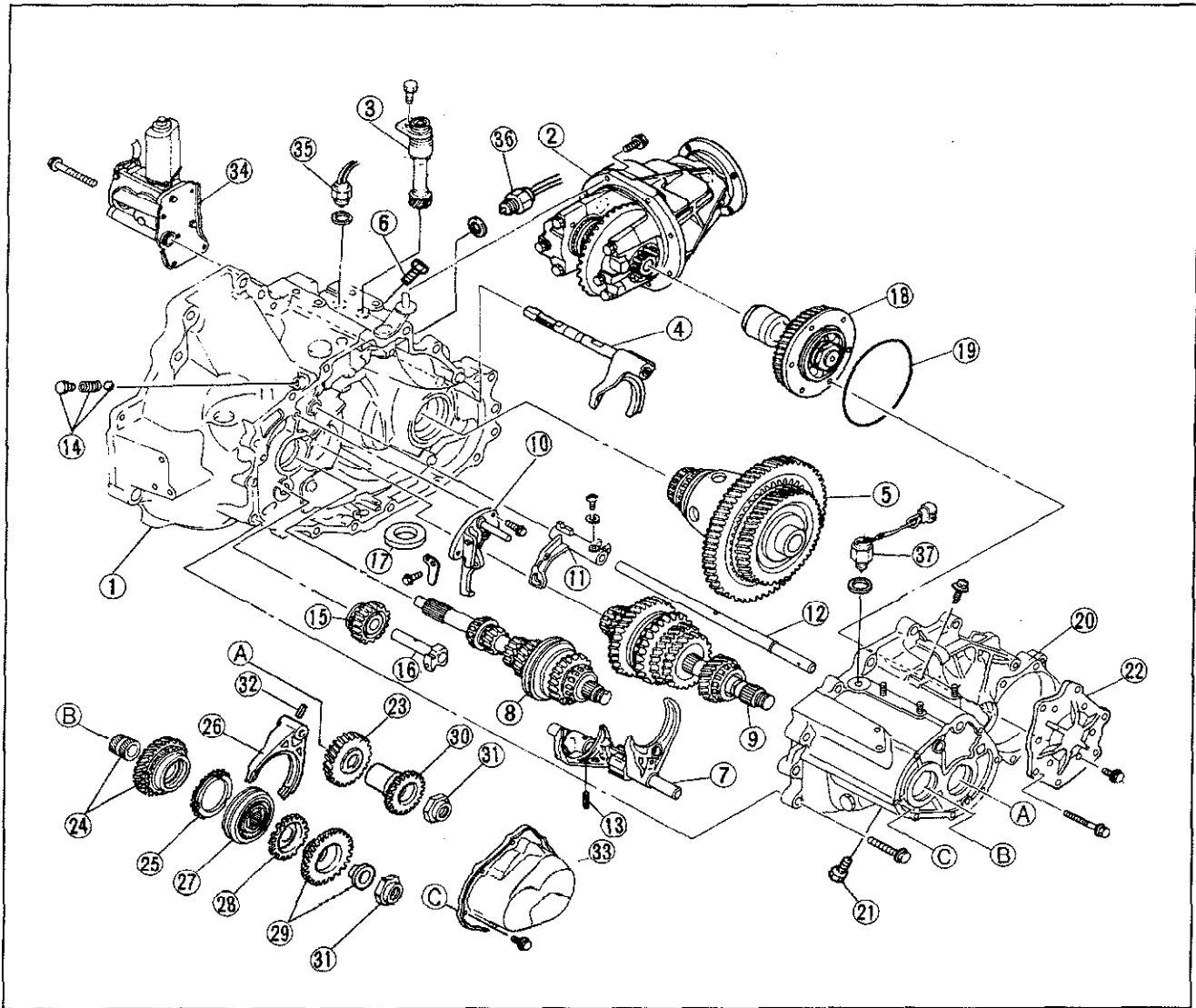

83U07C-024

- |   |                              |   |
|---|------------------------------|---|
| 1. Clutch housing                               | 12. Shift rod                | 27. Clutch hub assembly                               |
| 2. Transfer carrier assembly                    | 13. Spring pin               | 28. Synchronizer ring                                 |
| 3. Speedometer driven gear                      | 14. Ball, spring and bolt    | 29. Primary reverse synchronizer gear and gear sleeve |
| 4. Center differential lock shift fork assembly | 15. Reverse idle gear        | 30. Secondary reverse synchronizer gear               |
| 5. Center differential assembly                 | 16. Reverse idle shaft       | 31. Lock nut(s)                                       |
| 6. Bolt   | 17. Magnet                   | 32. Spring pin  |
| 7. Shift fork and shift rod assembly            | 18. Idle gear                | 33. Rear cover  |
| 8. Primary shaft gear assembly                  | 19. "O" ring                 | 34. Center differential lock motor                    |
| 9. Secondary shaft gear assembly                | 20. Transaxle case           | 35. Center differential lock switch                   |
| 10. Reverse lever support                       | 21. Bolt                     | 36. Neutral switch                                    |
| 11. Shift gate                                  | 22. Side cover               | 37. Backup lamp switch                                |
|   | 23. Secondary 5th gear       |   |
|   | 24. Gear sleeve and 5th gear |   |
|   | 25. Synchronizer ring        |   |
|   | 26. Shift fork               |   |

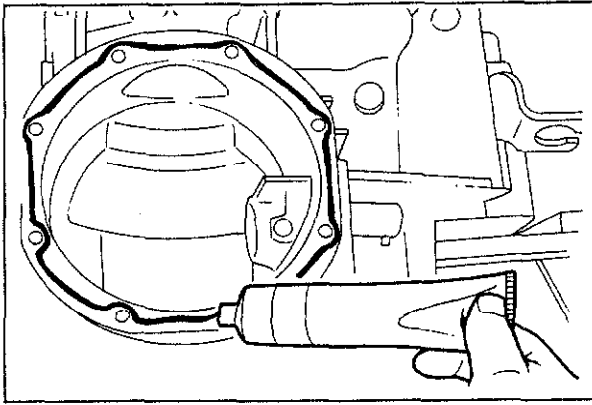

63G07C-230

**Transfer Carrier**

1. Coat both surfaces with sealant.
2. Install the transfer carrier assembly.

**Tightening torque: 25—30 N·m  
(2.5—3.1 m·kg, 18.1—22.4 ft·lb)**

**Note**

**Before coating with sealant, clean the contact surfaces.**

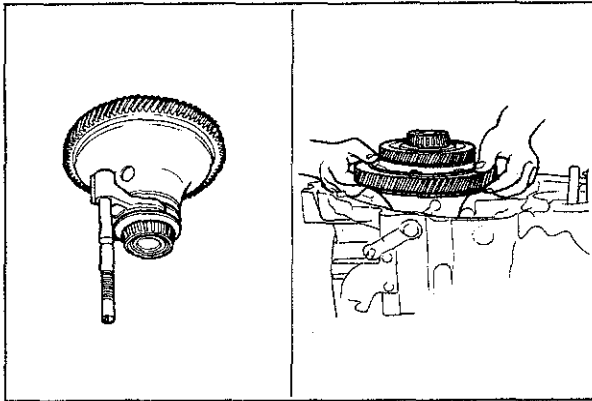

63G07C-229

**Front Differential Assembly**

1. Assemble the center differential lock shift fork assembly to the center differential assembly, and install the center differential assembly into the clutch housing.
2. Install the set bolt.

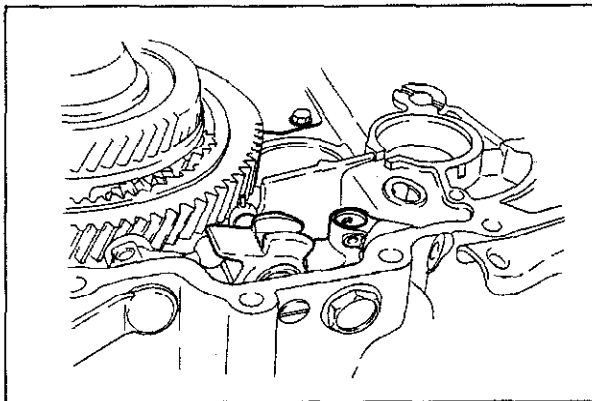

63G07C-231

**Shaft Gear and Shift Fork Assembly**

Install the primary shaft gear, secondary shaft gear, and shift fork assembly according to the following procedures:

1. Set the control end in place.

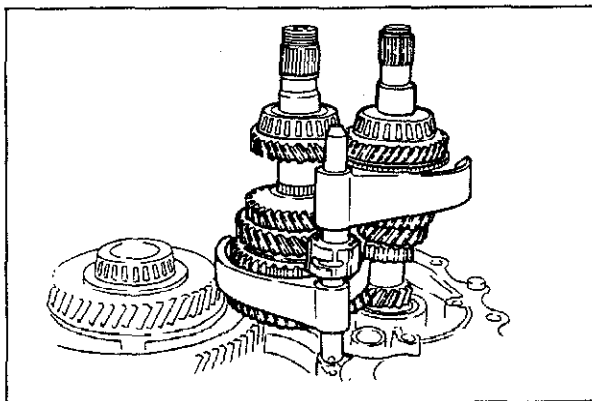

63G07C-232

2. Install the shift fork assembly on the secondary shaft gear assembly.
3. Unite the primary shaft gear, secondary shaft gear and shift fork assembly. Install the control rod into the control end as the unit is lowered into place.

**Note**

**Keep the assembly nearly vertical while installing.**

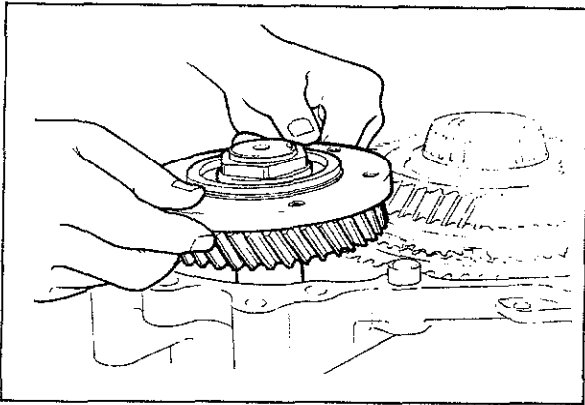

83U07C-025

### Idle Gear

Install the idle gear.

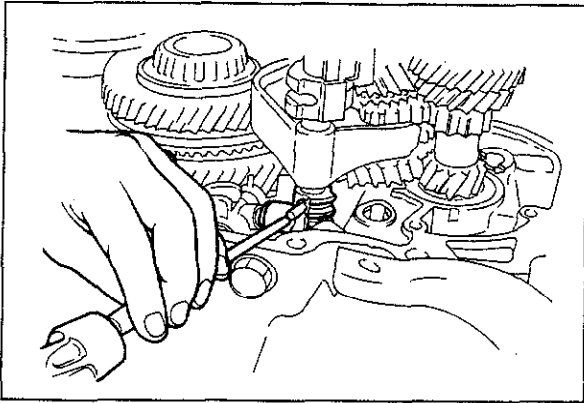

83U07C-026

### Control End

Tap the spring pin in with a pin punch and hammer.

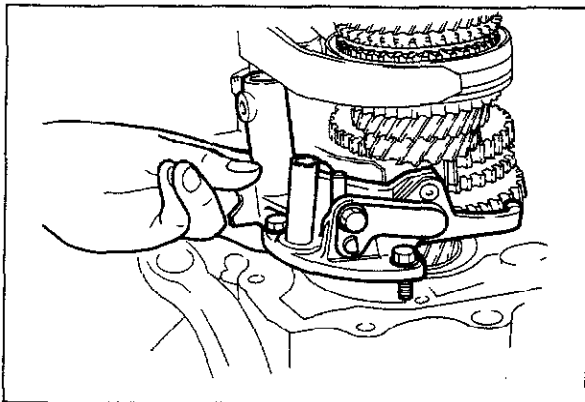

83U07C-027

### Reverse Lever Support and Shift Gate

1. Install the reverse lever support and shift gate.
2. Install the shift rod (5th/reverse)

**Tightening torque: 11.8—15.7 N·m**  
(1.2—1.6 m·kg, 8.7—11.6 ft·lb)

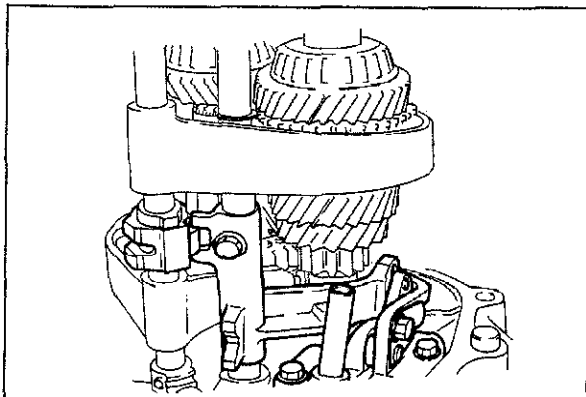

83U07C-028

3. Assemble the shift gate and install the shift rod then align the control lever and shift gate.
4. Tighten the set bolt.

**Tightening torque: 11.8—15.7 N·m**  
(1.2—1.6 m·kg, 8.7—11.6 ft·lb)

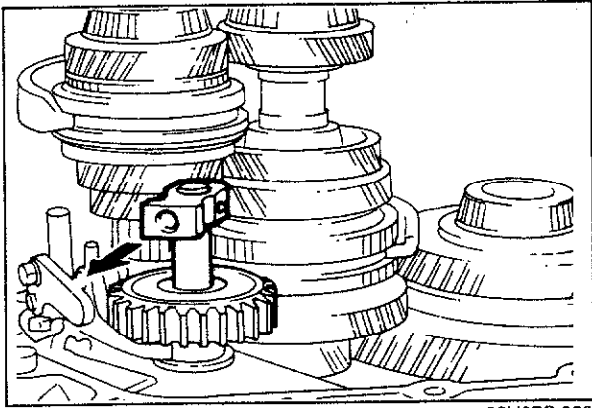

83U07C-029

**Reverse Idle Shaft**

Set the reverse idle shaft in the direction shown.

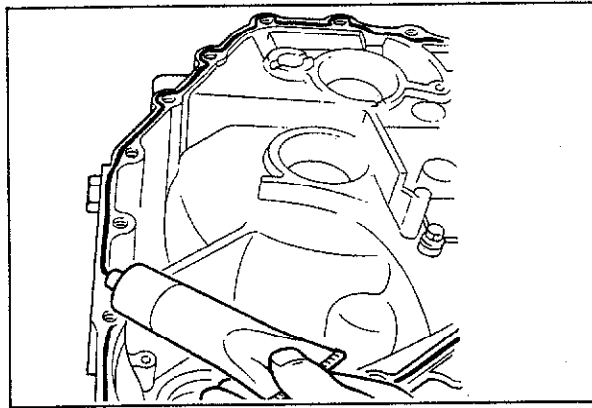

83U07C-030

**Transaxle Case**

1. Install the magnet.
2. Coat both surfaces with sealant.

**Note**

Before coating with sealant, clean the contact surfaces.

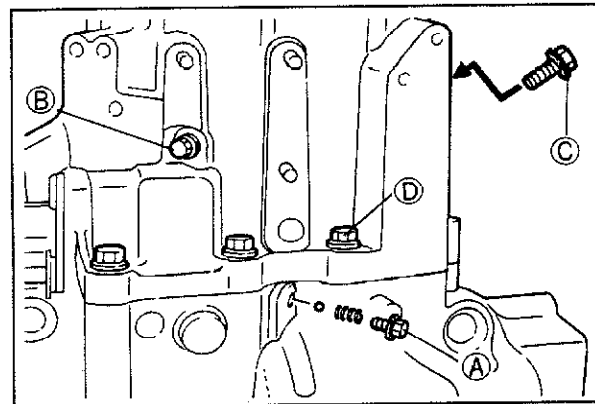

83U07C-031

3. Install the transaxle case.
4. Install the detent ball, spring and bolt (A), set bolts (B), (C) and case bolt (D).

**Note**

Coat the threads of (A) (B) (C) bolts with sealant before installing.

**Tightening torque:**

- (A) : 15—21 N·m  
(1.5—2.1 m·kg, 11—15 ft·lb)
- (B) : 9—14 N·m  
(90—140 cm·kg, 78—122 in·lb)
- (C) : 19—26 N·m  
(1.9—2.6 m·kg, 14—19 ft·lb)
- (D) : 37—52 N·m  
(3.8—5.3 m·kg, 27—38 ft·lb)

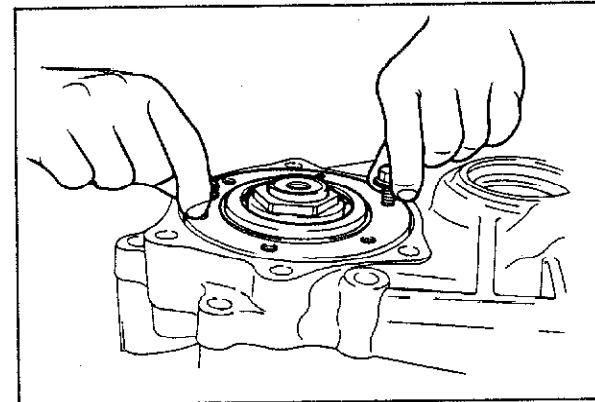

83U07C-032

**Side Cover**

1. Lift the idle gear slightly.

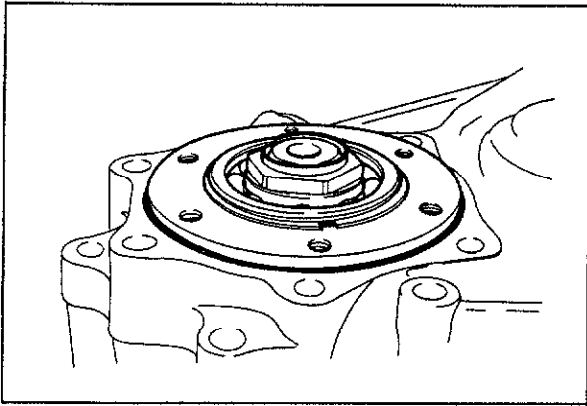

63G07C-241

2. Install the "O" ring.

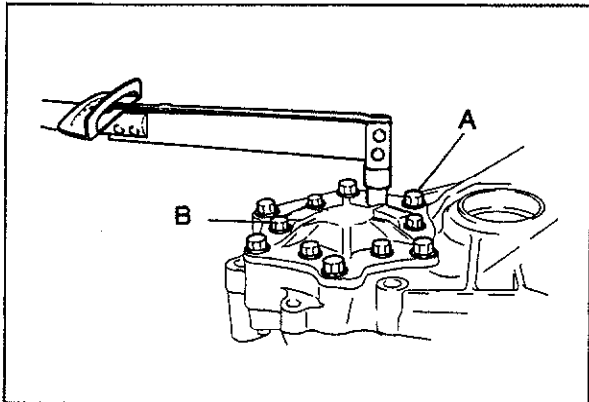

63G07C-242

3. Coat the side cover and clutch housing with sealant.

**Note**

**Before coating with sealant, clean the contact surfaces.**

4. Install the side cover.

**Tightening torque:**

**A. 37—52 N·m  
(3.8—5.3 m·kg, 27.5—38.3 ft·lb)**

**B. 19—25 N·m  
(1.9—2.6 m·kg, 14—19 ft·lb)**

**5th Gear**

1. Install the **SST** to hold the side gear.

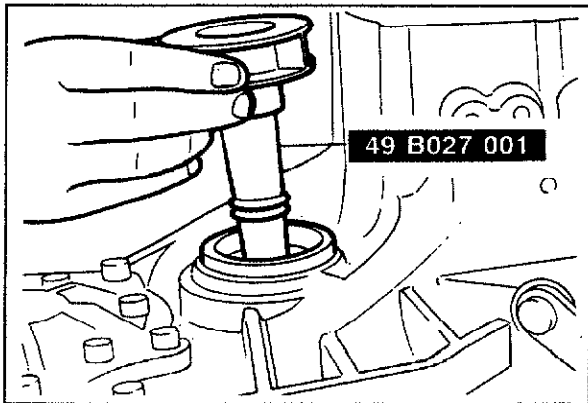

83U07C-033

2. Install the secondary 5th gear.

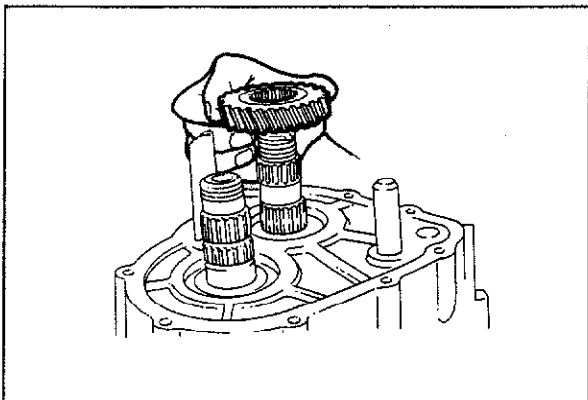

83U07C-034

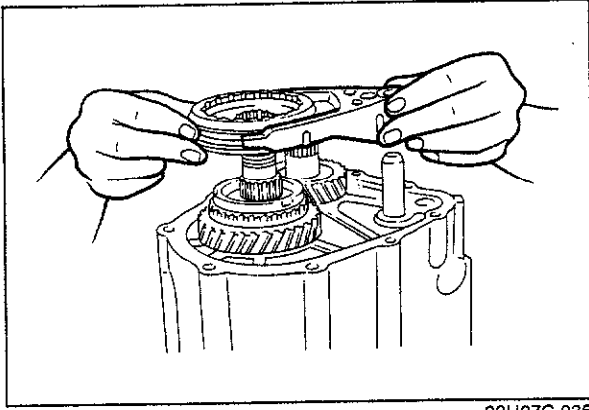

83U07C-035

3. Install the gear sleeve, the 5th gear and synchronizer ring.
4. Install the shift fork together with clutch hub assembly.

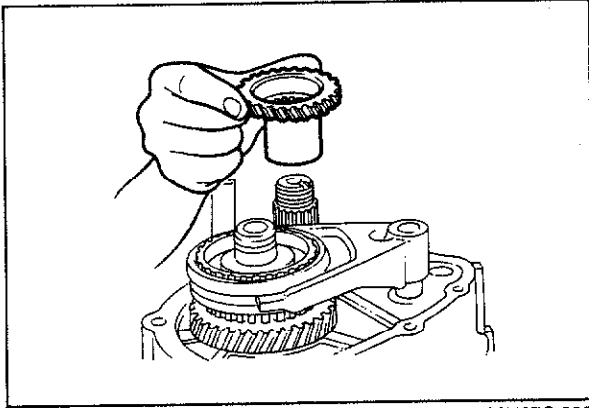

83U07C-036

5. Install the synchronizer ring.
6. Install the gear sleeve and reverse synchronizer gears.

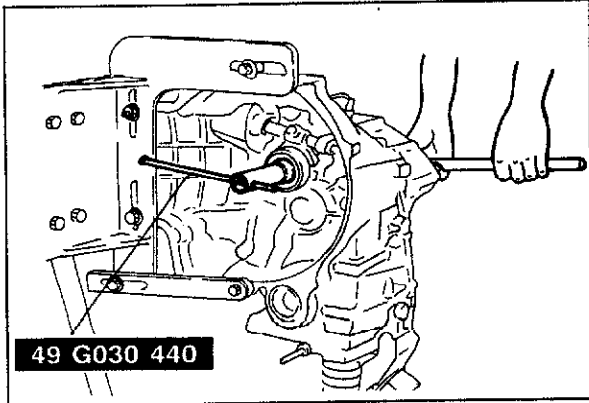

83U07C-037

7. Shift the lever into 1st gear.
8. Lock the primary shaft with the **SST**.
9. Use new lock nuts and tighten it to the specified torque.

**Tightening torque:**

**127—206 N·m (13—21 m·kg, 94—152 ft·lb)**

10. Stake the lock nuts to the groove.

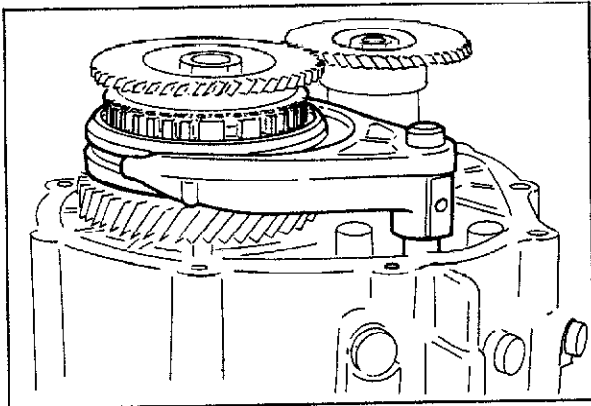

83U07C-038

11. Shift to neutral and install the spring pin.

**Note**

**After installation, move the shift rod to check to be sure that the gear change operation is smooth.**



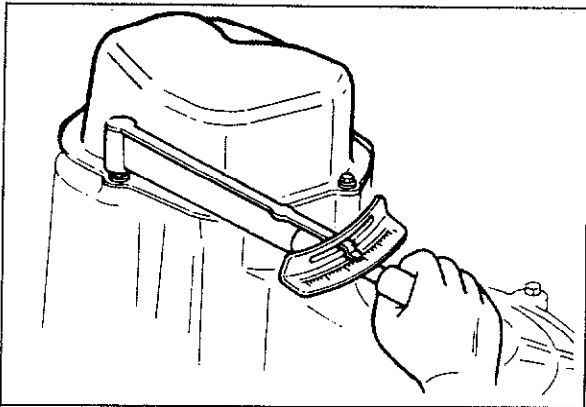

83U07C-039

## Rear Cover

1. Coat the transaxle case and rear cover with sealant.

### Note

**Before coating with sealant, clean the contact surfaces.**

2. Install the rear cover.

### Tightening torque:

**8—11 N·m (80—110 cm·kg, 69—95 in·lb)**

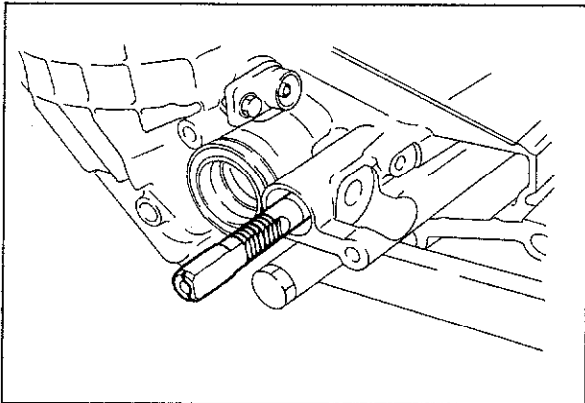

63G07C-258

## Center Differential Lock Assembly

1. Position the center differential lock shift rod as shown in the figure.
2. Install the center differential lock assembly.

### Tightening torque:

**19—25 N·m (1.9—2.6 m·kg, 14—19 ft·lb)**

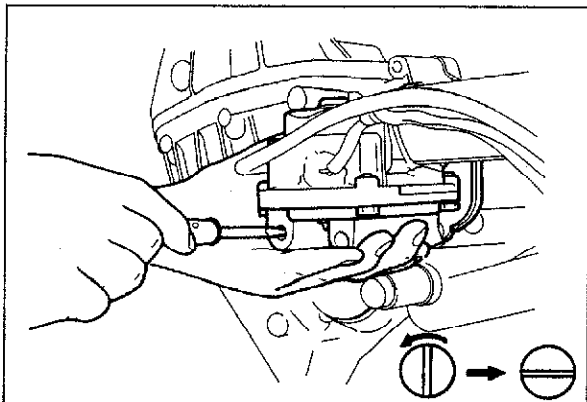

83U07C-040

3. Turn the rod 90° counterclockwise with a flat-tipped screwdriver.
4. Install the bolts.

### Tightening torque:

**9—14 N·m (90—140 cm·kg, 78—122 ft·lb)**

5. Install the differential lock switch.

### Tightening torque:

**20—29 N·m (2—3 m·kg, 14—22 ft·lb)**

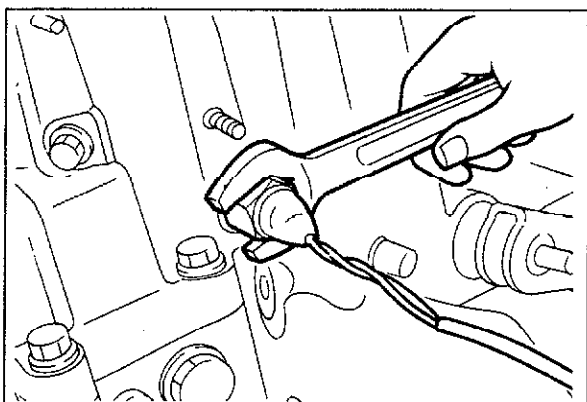

63G07C-257

## Switch

Install the neutral switch and backup lamp switch.

### Tightening torque:

**20—29 N·m (2—3 m·kg, 14—22 ft·lb)**

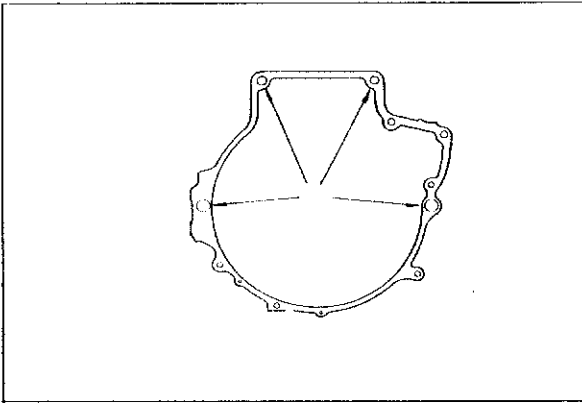

63G07C-261

## INSTALLATION

Install in the reverse order of removal and be careful of the following.

### Transaxle and Transfer

Tighten the bolts.

**Tightening torque: 89—117 N·m  
(9.1—11.9 m·kg, 66—86 ft·lb)**

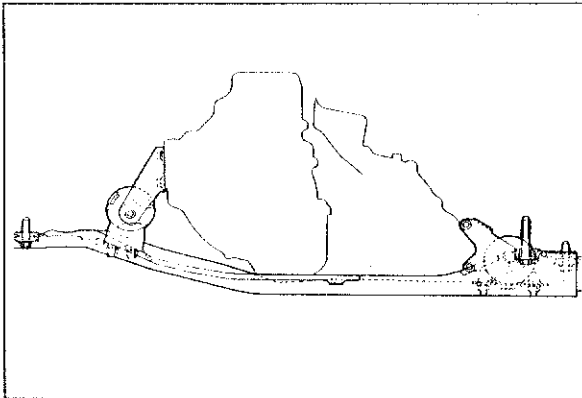

63G07C-262

### Crossmember

Install the crossmember.

**Tightening torque: 64—89 N·m  
(6.5—9.1 m·kg, 47—66 ft·lb)**

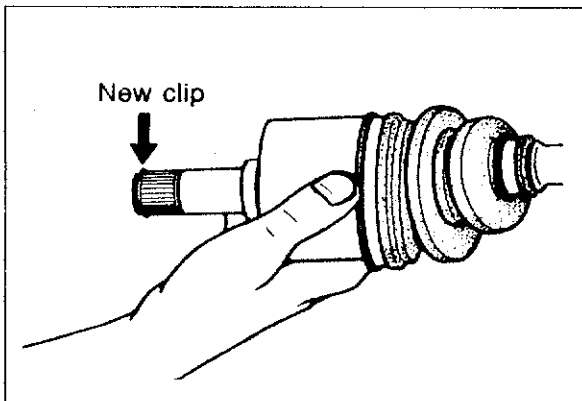

63U07A-143

### Clip

Replace the clip at the end of the driveshaft with a new one. Insert the clip with gap to the top of the groove.

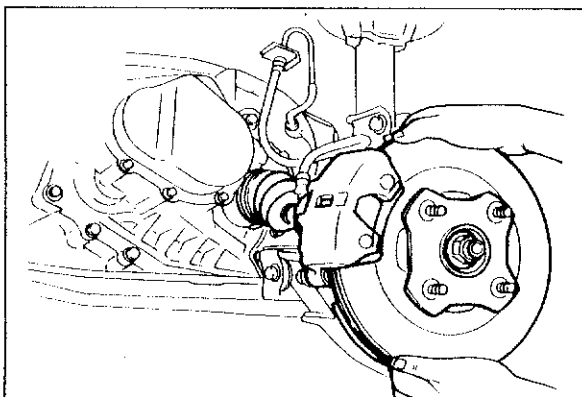

63G07C-263

### Driveshaft

1. Install driveshaft to transaxle.

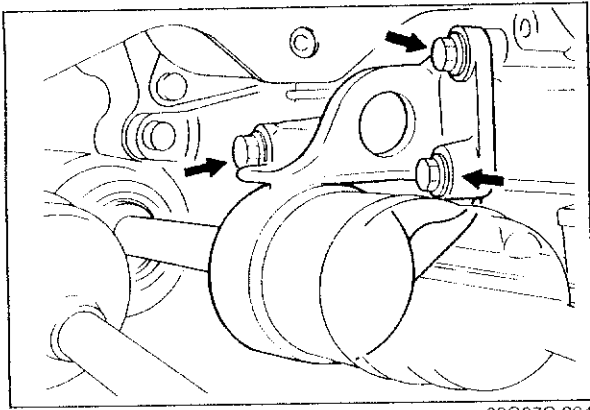

63G07C-264

2. Install joint shaft.

**Tightening torque:**

42—62 N·m (4.3—6.3 m·kg, 31—46 ft·lb)

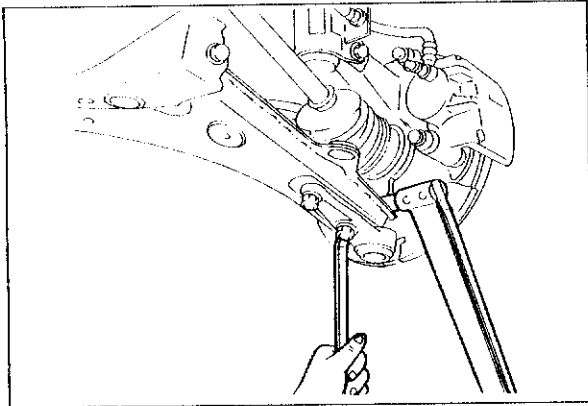

63G07C-265

**Lower Arm**

Install the lower arm ball-joint to the knuckle and the tighten the bolt.

**Tightening torque:**

43—54 N·m (4.4—5.5 m·kg, 32—40 ft·lb)

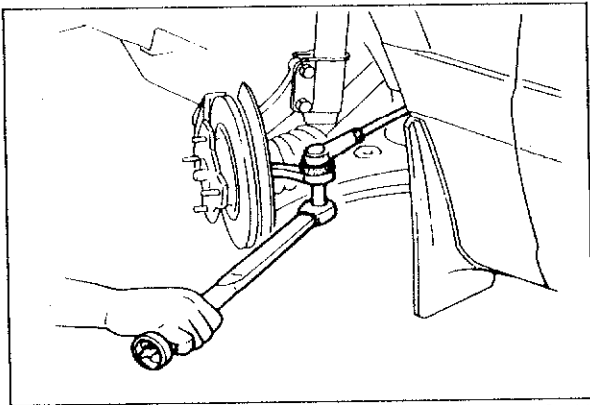

63G07C-266

**Tie-rod End**

Install tie-rod end to knuckle.

**Tightening torque:**

29—44 N·m (3.0—4.5 m·kg, 22—33 ft·lb)

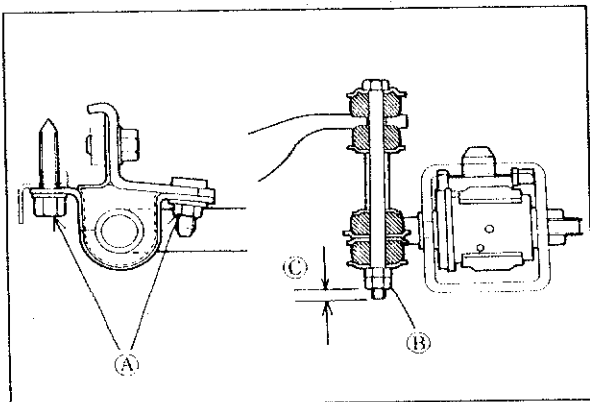

63G07C-267

**Stabilizer**

Install and adjust the front stabilizer.

**Tightening torque:**

Ⓐ : 31—44 N·m

(3.2—4.5 m·kg, 23—33 ft·lb)

Ⓑ : 12—18 N·m

(1.2—1.8 m·kg, 9—13 ft·lb)

Dimension Ⓒ : 8.8 mm (0.35 in)

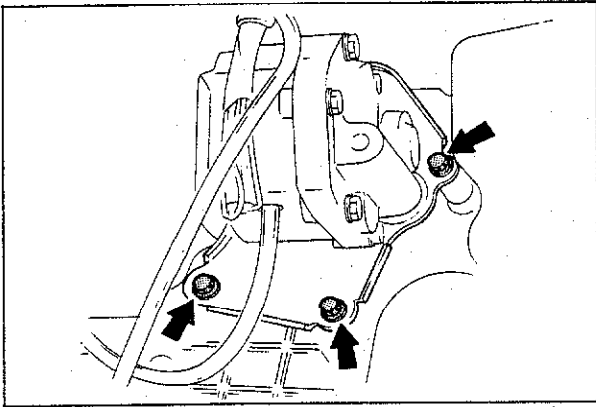

63G07C-268

### Starter and Center Differential Lock Assembly.

1. Install the starter.
2. Install the center differential lock assembly.

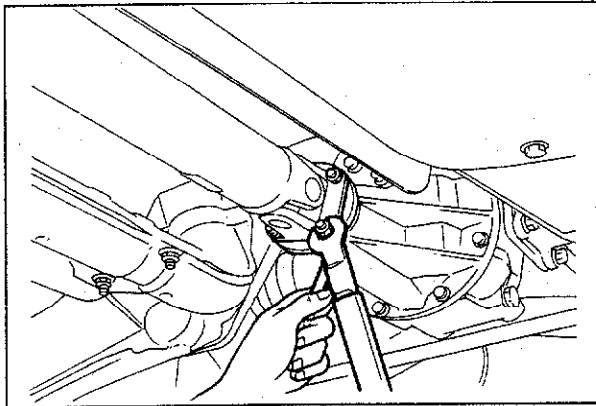

63G07C-269

### Propeller Shaft

1. Install the propeller shaft.
2. Install the side cover and undercover (right side).

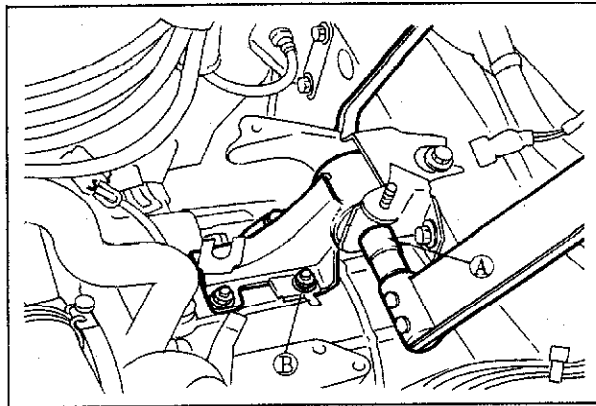

63G07C-270

### Wheel

1. Install the wheels.

#### Tightening torque:

**88—118 N·m (9—12 m·kg, 65—87 ft·lb)**

2. Install mount bracket No. 4.

#### Tightening torque:

**(A) : 50—61 N·m  
(5.1—6.2 m·kg, 37—45 ft·lb)**

**(B) : 19—26 N·m  
(1.9—2.6 m·kg, 14—19 ft·lb)**

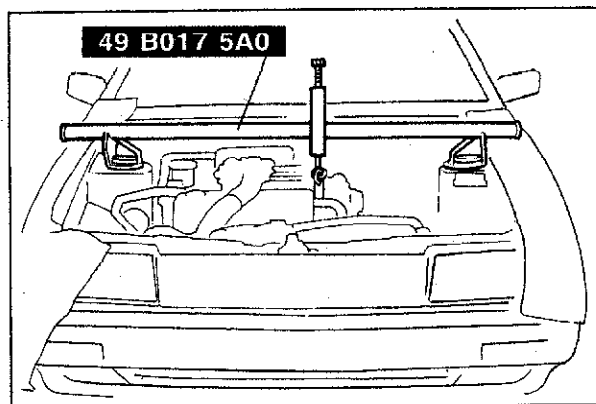

63G07C-271

### Mounting Block

Remove the engine support, and tighten the mounting block installation nuts to the specified torque.

#### Tightening torque:

**23—29 N·m (2.3—3.0 m·kg, 17—22 ft·lb)**

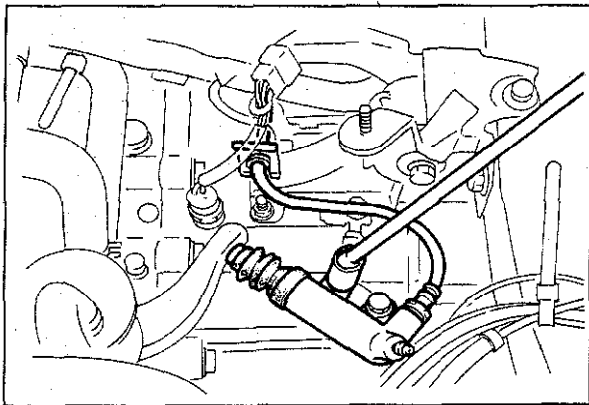

63G07C-272

### Clutch Release Cylinder

1. Set the hose in the bracket and install clip.
2. Install the clutch release cylinder.

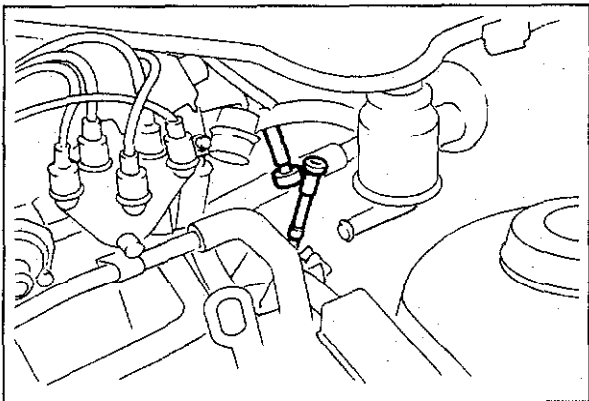

63G07C-273

### Speedometer Cable

1. Connect the speedometer cable.
2. Install the air cleaner.

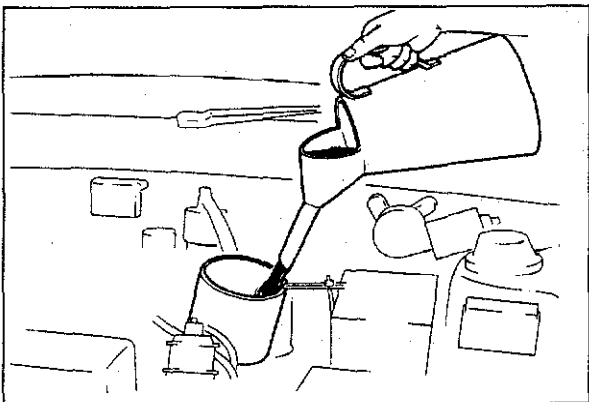

63G07C-274

### Transaxle Oil

1. Add the specified amount of the specified trans-axle oil through the speedometer driven gear installation hole.
2. Road test the vehicle and check the transaxle and transfer carrier for proper operation and check for oil leaks.

## TRANSAXLE CONTROL-1

### REMOVAL AND INSTALLATION

1. Jack up the vehicle and support it with safety stands.
2. Remove the parts in the sequence shown in the figure.
3. Install in the reverse order of removal.

63G07C-275

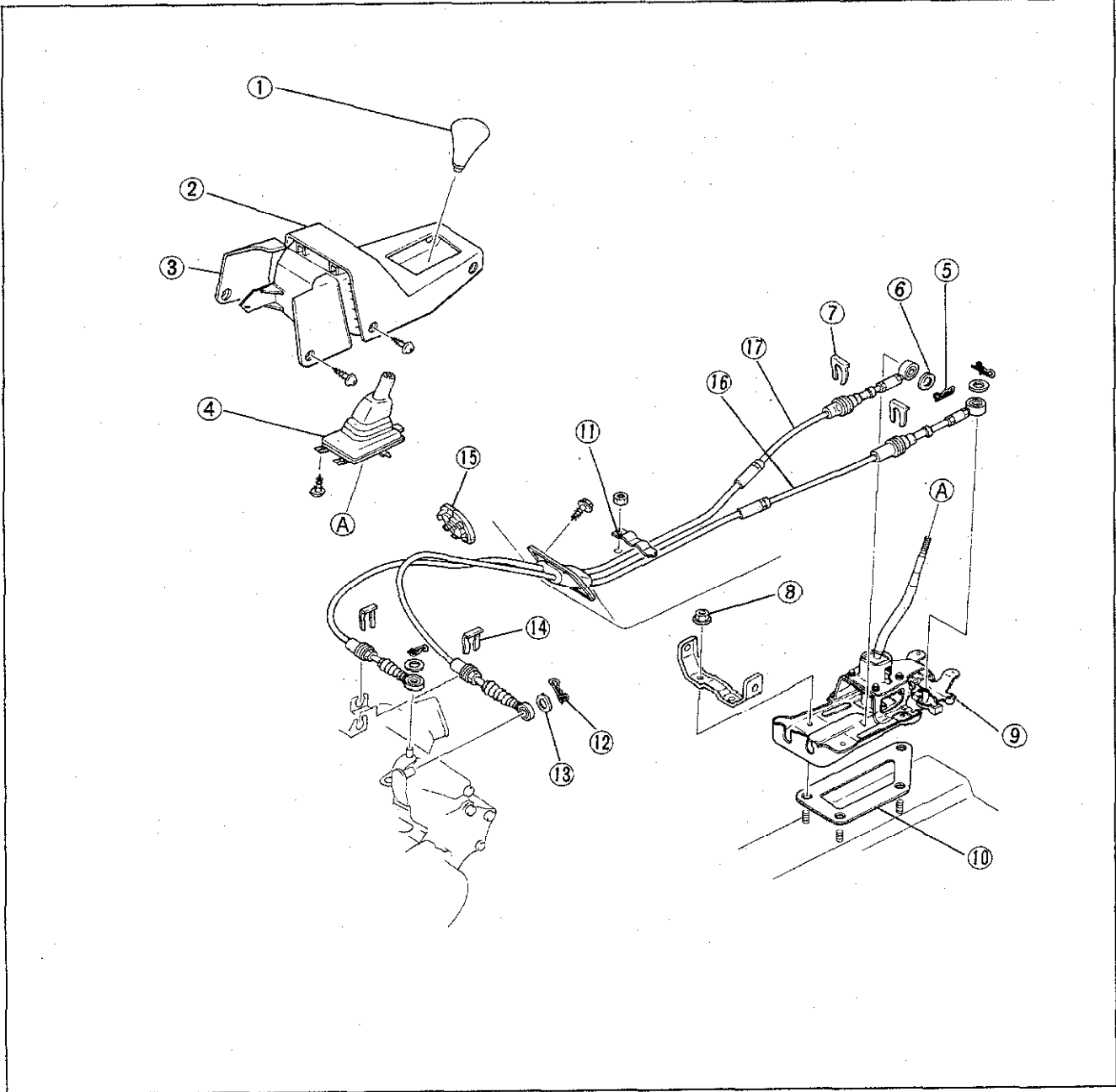

63G07C-278

1. Shift lever knob
2. Center console
3. Side wall
4. Shift lever boot
5. Pin
6. Flat washer

7. Clip
8. Nut
9. Shift lever assembly
10. Rubber seat
11. Cable clip

12. Pin
13. Flat washer
14. Clip
15. Dust cover
16. Select cable
17. Shift cable

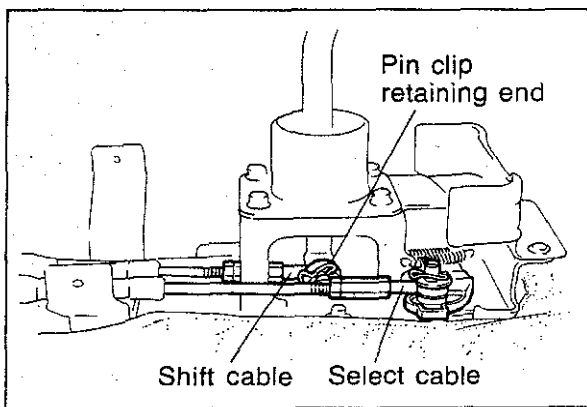

83U07C-041

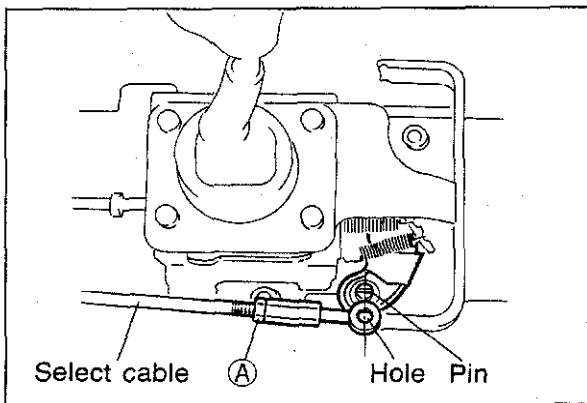

73G07C-008

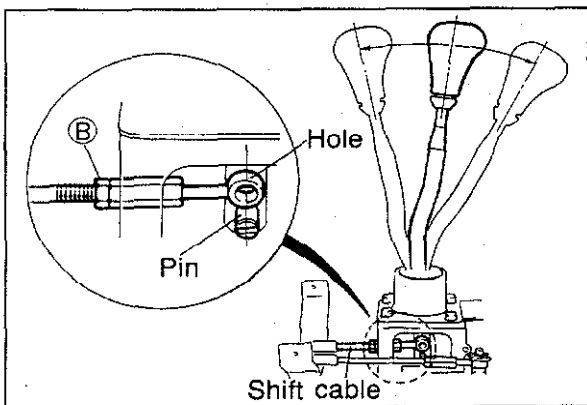

73G07C-009

## Shift Lever Position Adjustment

1. Set the transaxle shift lever to neutral position.
2. Check that the shift and select levers on the transaxle are in the neutral position.
3. Remove the console.
4. Disconnect the shift and select cables from levers.

### Note

Replace the pin clips with a new one. If it re-used, check the retaining end of it for deformation.

5. Check that the select cable end hole aligns perfectly with the select lever pin.
6. If not aligned, loosen nut (A), and turn the adjust nut to align.

7. Position the transaxle shift lever at the center of its front-to-rear stroke.
8. Check that the shift cable end hole aligns perfectly with shift lever pin.
9. If not aligned, loosen nut (B), and turn the adjust nut to align.
10. Connect the shift and select cables, and tighten nuts (A) and (B).

**Tightening torque: 6.9—9.8 N·m  
(70—100 cm·kg, 61—87 in·lb)**

11. Secure the cables with the flat washers and spring clips.

**TRANSAXLE CONTROL-2**

**REMOVAL AND INSTALLATION**

1. Remove the part in the sequence shown in the figure.
2. Install in the reverse order of removal.

63G07C-279

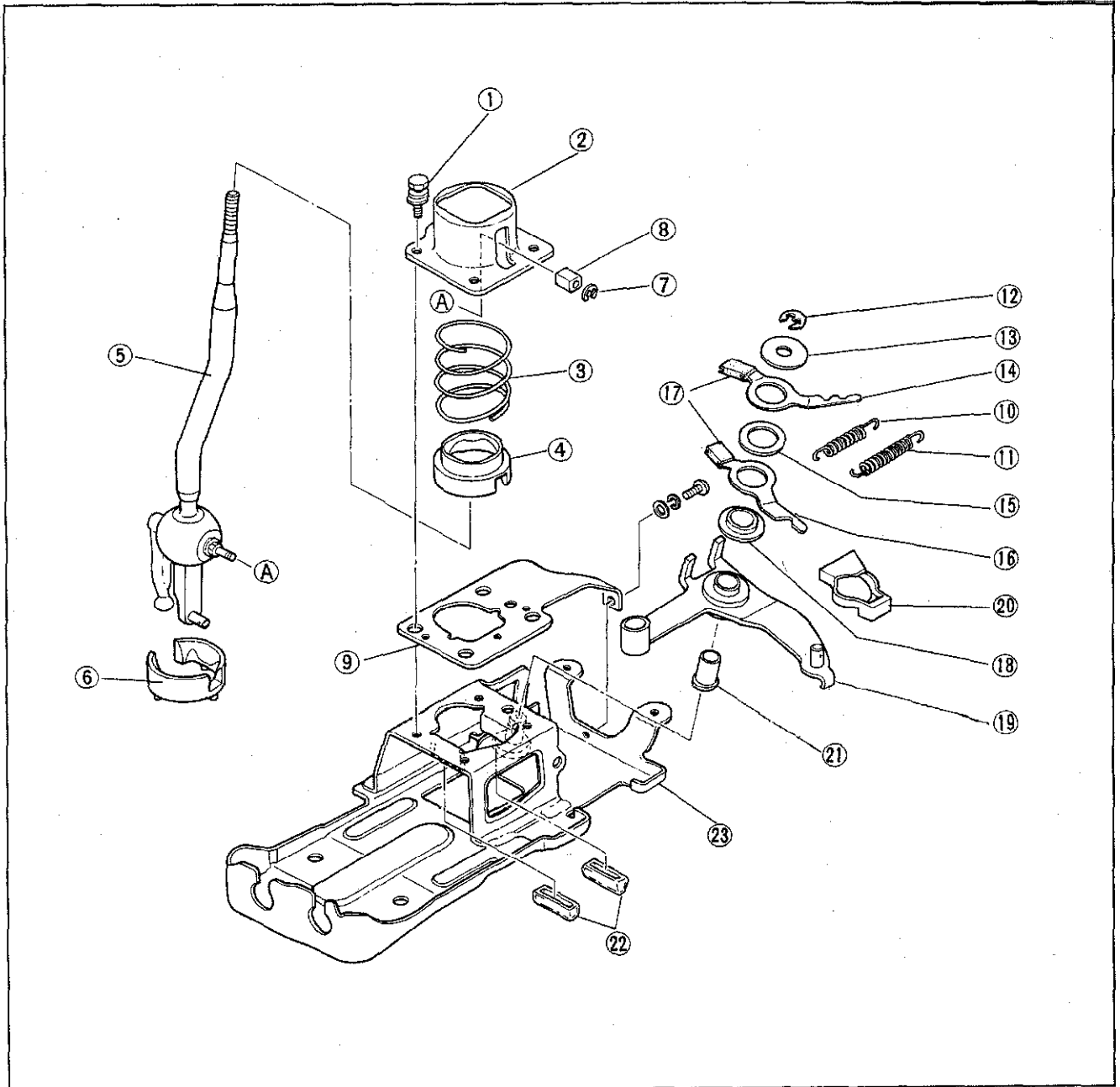

63G07C-279

- |                    |                    |                         |
|--------------------|--------------------|-------------------------|
| 1. Bolt            | 9. Support plate   | 17. Select stopper      |
| 2. Ball seat cover | 10. Return spring  | 18. Bushing             |
| 3. Spring          | 11. Assist spring  | 19. Select lever        |
| 4. Ball seat No. 2 | 12. Retaining ring | 20. Crank lever sleeve  |
| 5. Shift lever     | 13. Washer         | 21. Stopper rubber      |
| 6. Ball seat No. 1 | 14. Lever No. 1    | 22. Shift stopper       |
| 7. Retaining ring  | 15. Plate          | 23. Shift lever bracket |
| 8. Cover           | 16. Lever No. 2    |                         |



# PROPELLER SHAFT

<b>OUTLINE</b> .....	<b>8— 2</b>
<b>OUTLINE OF CONSTRUCTION</b> .....	<b>8— 2</b>
<b>STRUCTURAL VIEW</b> .....	<b>8— 2</b>
<b>SPECIFICATIONS</b> .....	<b>8— 3</b>
<b>TROUBLESHOOTING GUIDE</b> .....	<b>8— 3</b>
<b>ON-VEHICLE CHECK</b> .....	<b>8— 4</b>
<b>PROPELLER SHAFT</b> .....	<b>8— 5</b>
<b>REMOVAL</b> .....	<b>8— 5</b>
<b>DISASSEMBLY</b> .....	<b>8— 6</b>
<b>INSPECTION</b> .....	<b>8— 8</b>
<b>ASSEMBLY</b> .....	<b>8— 9</b>
<b>INSTALLATION</b> .....	<b>8—12</b>

63G08X-300

# 8 OUTLINE

## OUTLINE

### OUTLINE OF CONSTRUCTION

Standard universal joints are installed on the propeller shaft.

63G08X-301

### STRUCTURAL VIEW

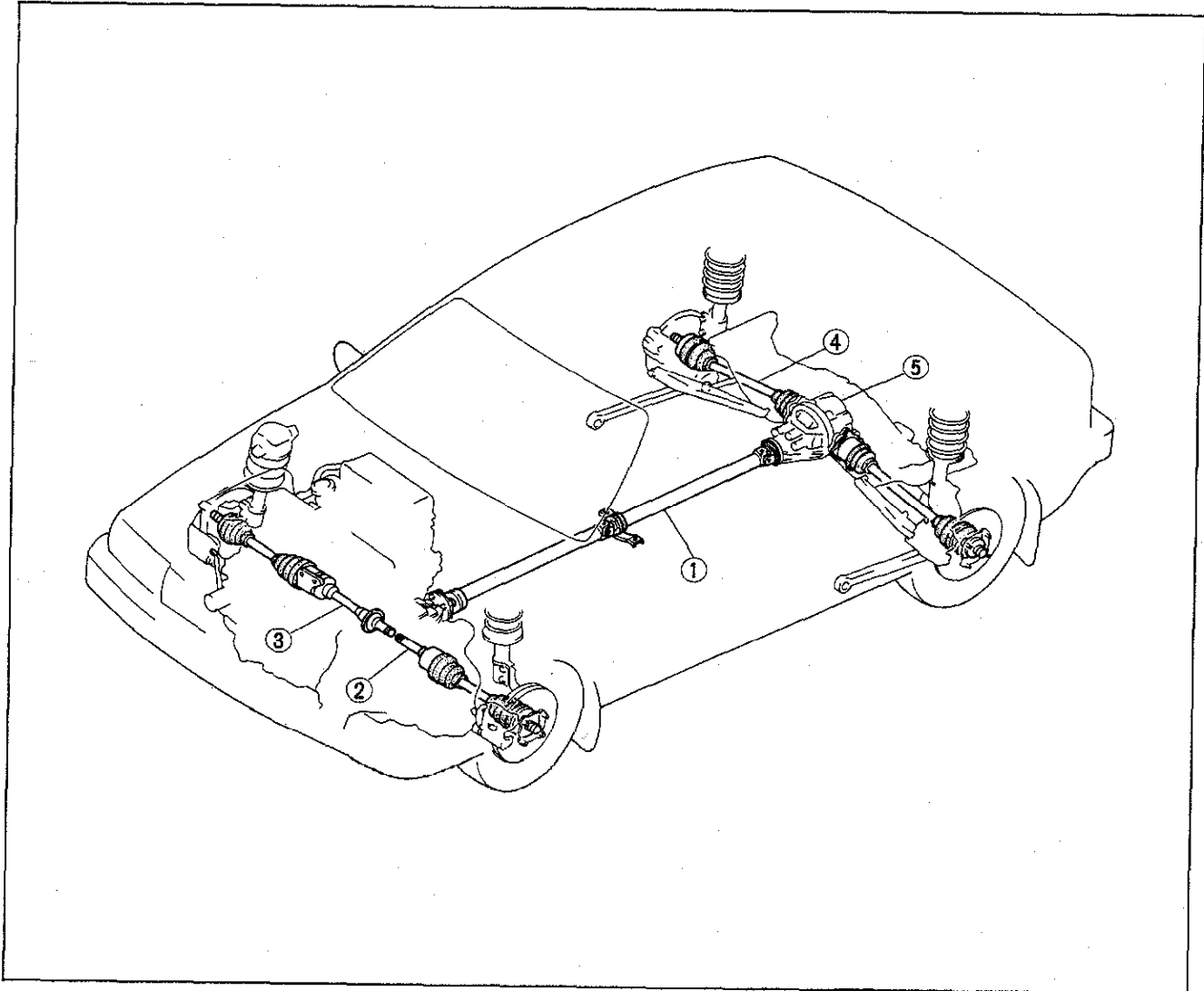

83U08X-001

- 1. Propeller shaft
- 2. Driveshaft (front)
- 3. Joint shaft

- 4. Driveshaft (rear)
- 5. Rear differential

**SPECIFICATIONS**

Length	mm (in)	L	1788 (70.39)
Outer diameter	mm (in)	D1	57 (2.24)
		D2	65 (2.56)

63G08X-303

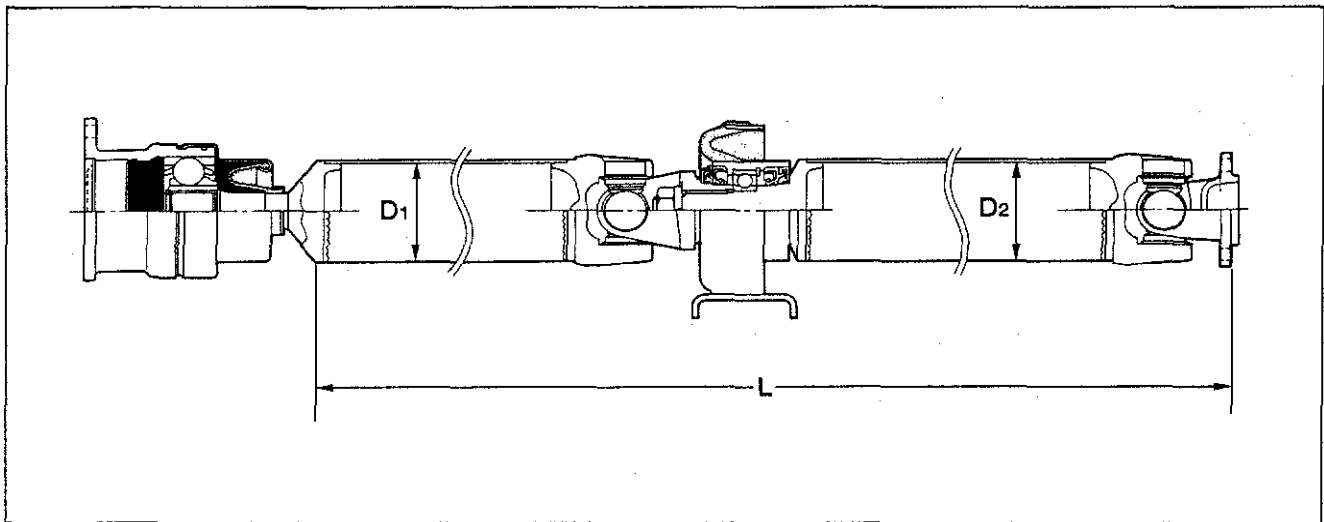

**TROUBLESHOOTING GUIDE**

Problem	Possible Cause	Remedy
<b>Vibration</b>	Bent propeller shaft Left/right universal joint snap rings not symmetrical Loosen yoke installation	Replace Adjust Tighten
<b>Noise</b>	Worn or damaged universal joint bearing Universal joint snap ring missing Loose yoke installation	Replace Repair Tighten

63G08X-304

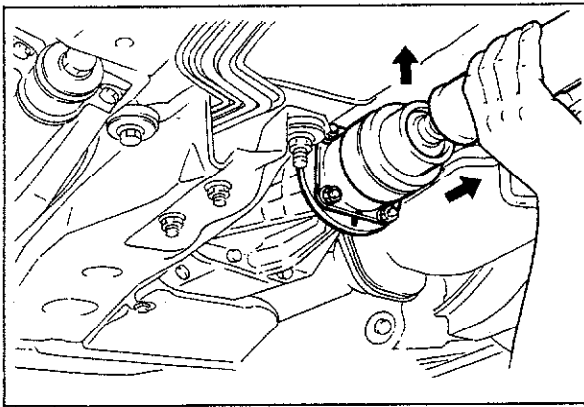

63G08X-305

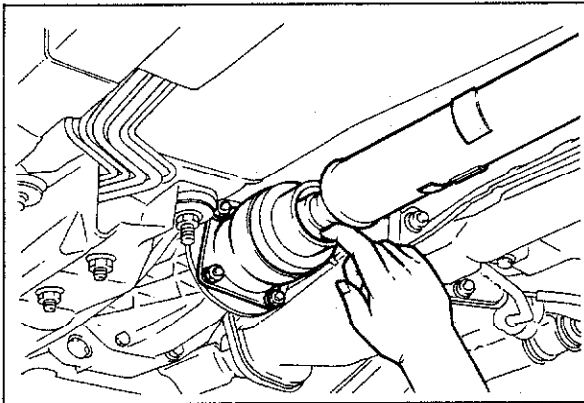

63G08X-306

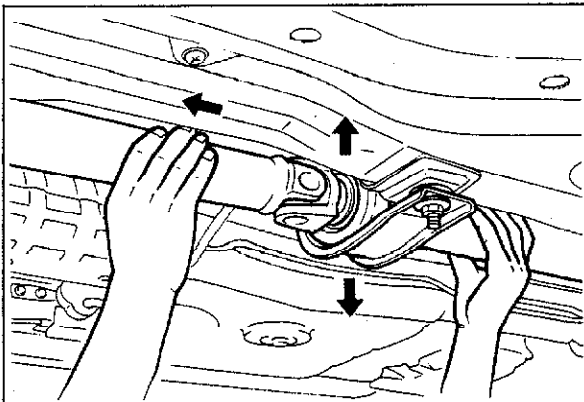

63G08X-307

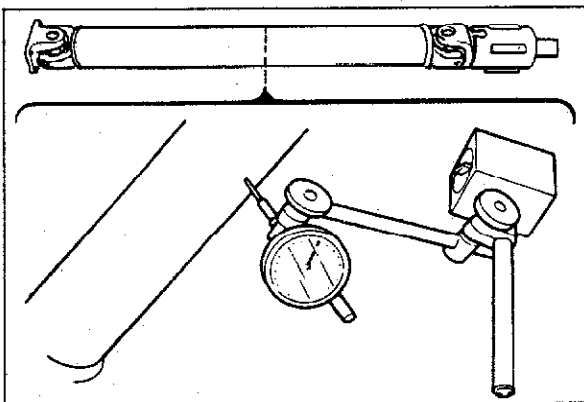

63G08X-308

## ON-VEHICLE CHECK

Check the following points. If a problem is found replace the necessary part.

1. Check for backlash by moving the parts as shown in the figure.
2. Check for looseness of bolts and nuts, and tighten if necessary.

3. Check for cracks or damage of dust boot.

4. Check for backlash of center bearing.

5. Check for runout of propeller shaft.

**Runout limit: 0.4 mm (0.016 in)**

## PROPELLER SHAFT

### REMOVAL

1. Jack up the vehicle and support it on safety stands.
2. Remove the parts in the sequence shown in the figure.

63G08X-309

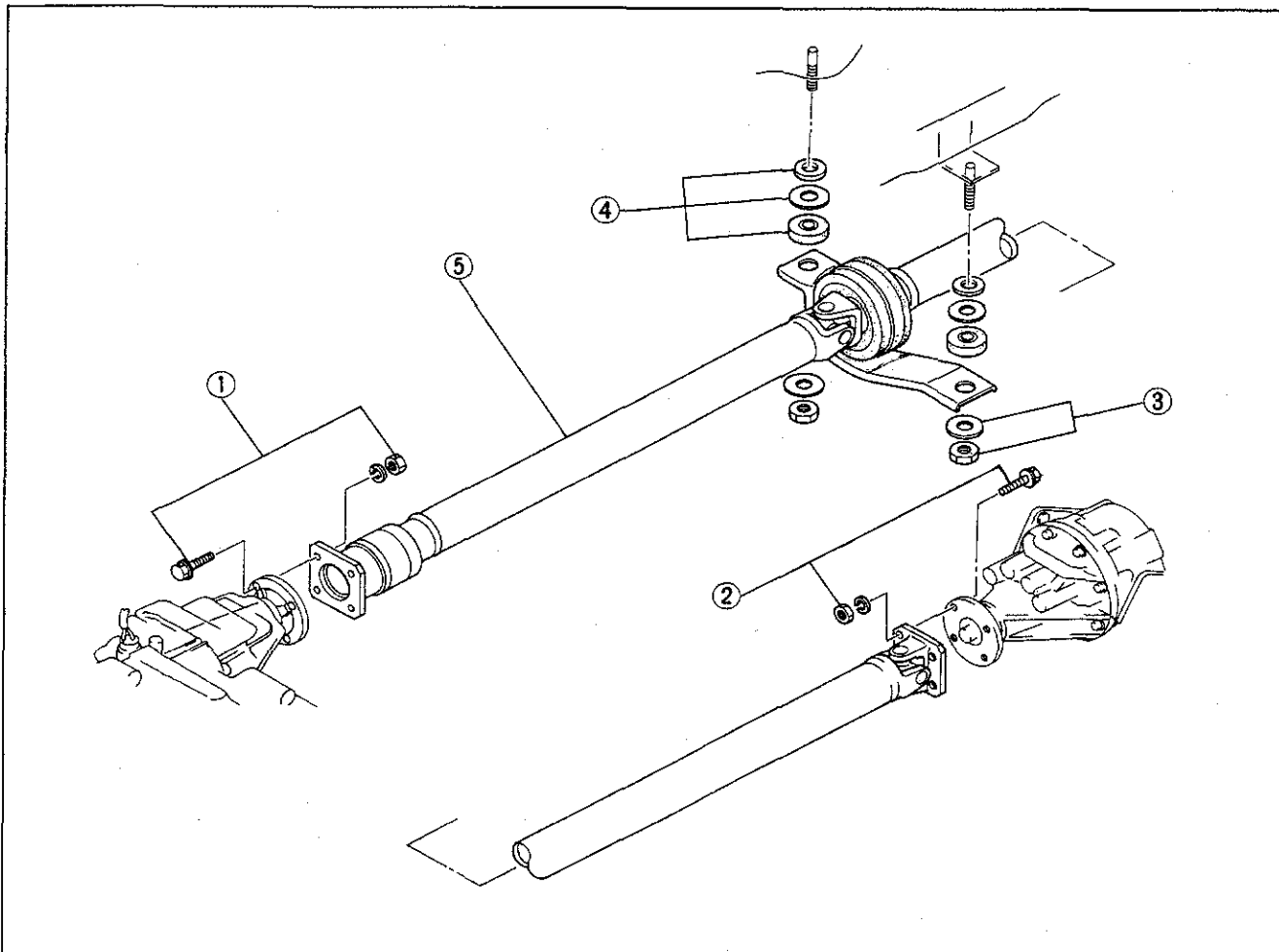

63G08X-309

1. Bolts and nuts (front)
2. Bolts and nuts (rear)
3. Nuts and washers

4. Bushings washers and shims
5. Propeller shaft

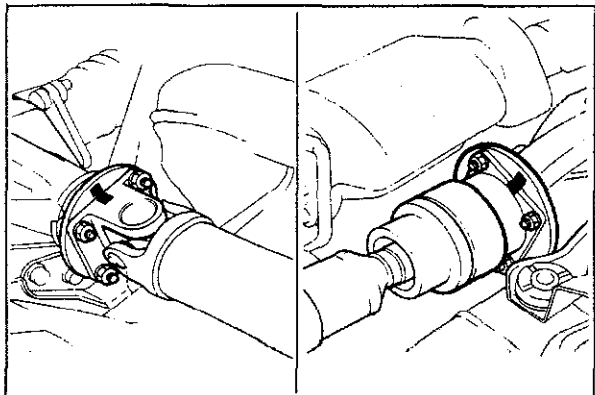

63G08X-310

### Propeller Shaft

Before removing the propeller shaft, put matching marks on the flanges. Use the marks of proper reinstallation.

# 8 DISASSEMBLY

## DISASSEMBLY

Disassemble the parts in the sequence shown in the figure.

63G08X-311

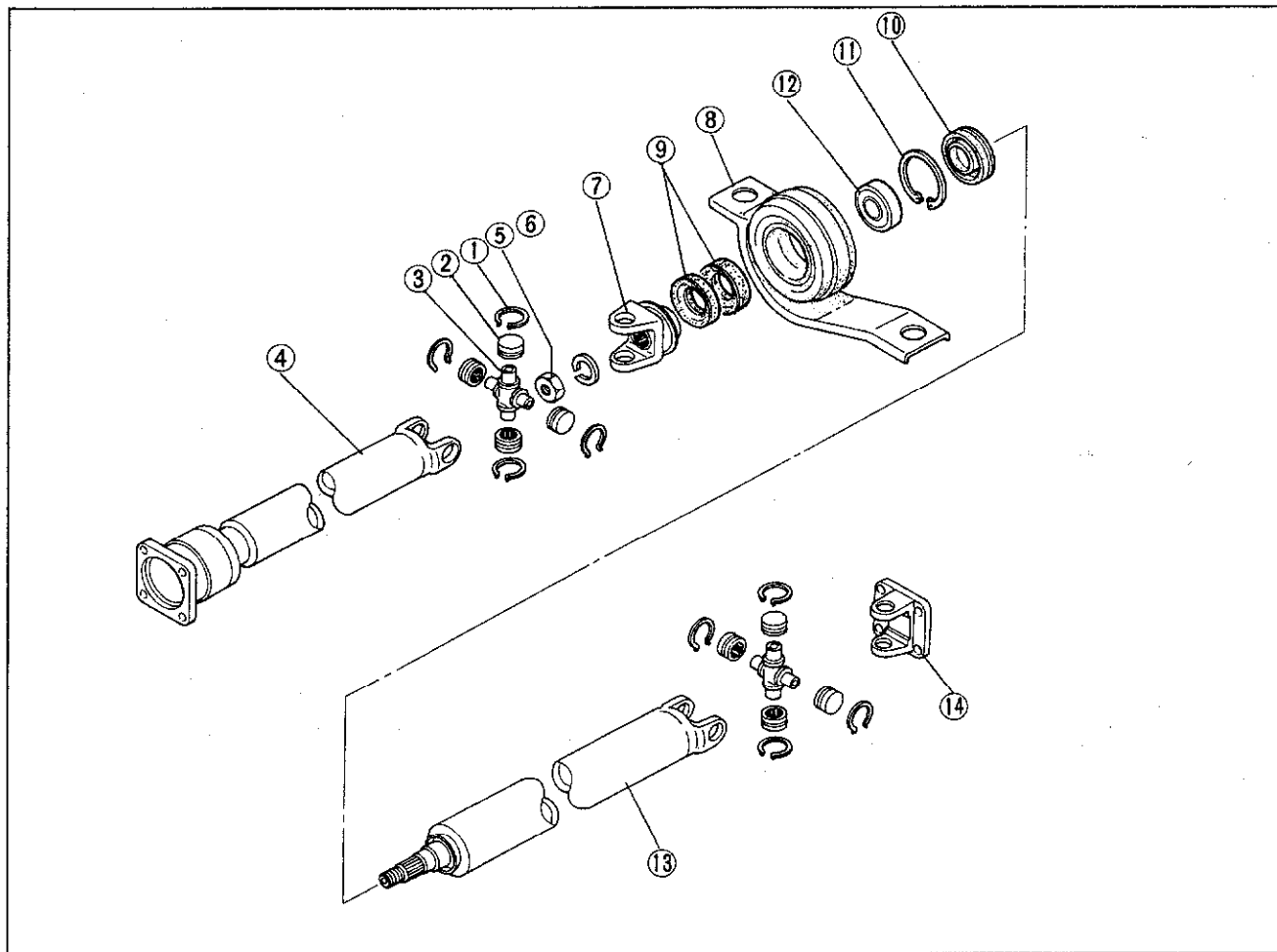

63G08X-312

- 1. Snap ring
- 2. Bearing
- 3. Spider
- 4. Front propeller shaft
- 5. Lock nut

- 6. Washer
- 7. Center yoke
- 8. Center bearing support  
ass'y
- 9. Dust seal (front)

- 10. Dust seal (rear)
- 11. Snap ring
- 12. Bearing
- 13. Rear propeller shaft
- 14. Rear yoke

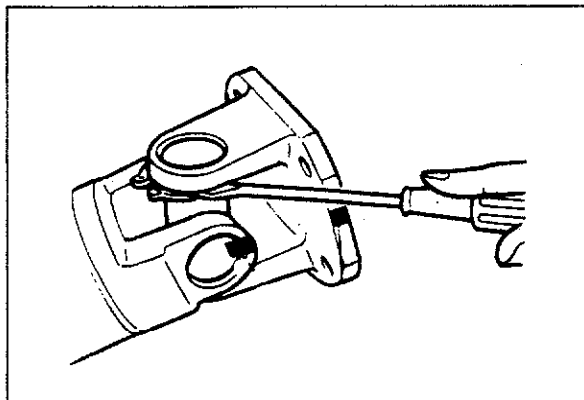

63G08X-313

### Yoke

- 1. Place the propeller shaft in a vise.

#### Caution

**Use pads in the vise so as not to damage the propeller shaft.**

- 2. Make matching marks on the propeller shaft, spider and yoke.

#### Caution

**If the propeller shaft, spider and yoke are not correctly combined when assembled, vibration may result.**

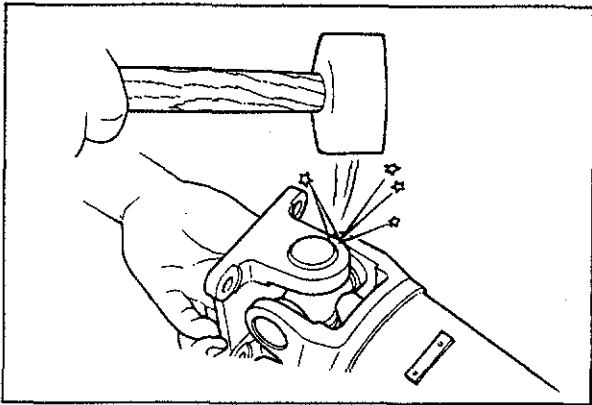

63G08X-314

3. Remove all snap rings using a flat-tip screwdriver.

**Caution**

**The snap rings cannot be re-used.**

4. Remove the bearings by lightly tapping the yoke with a brass hammer as shown in the figure.
5. Remove the yoke.

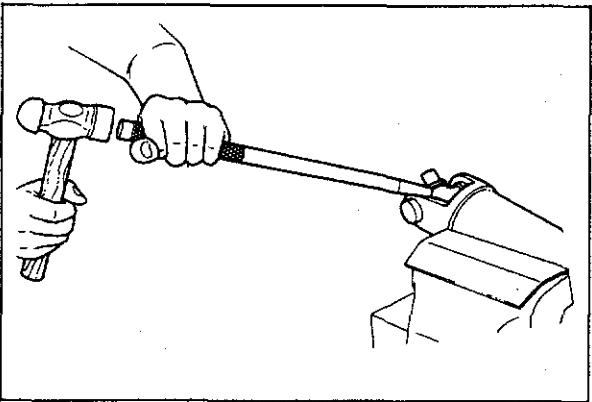

63G08X-315

**Spider**

1. Remove the bearings as shown in the figure.
2. Remove the spider.

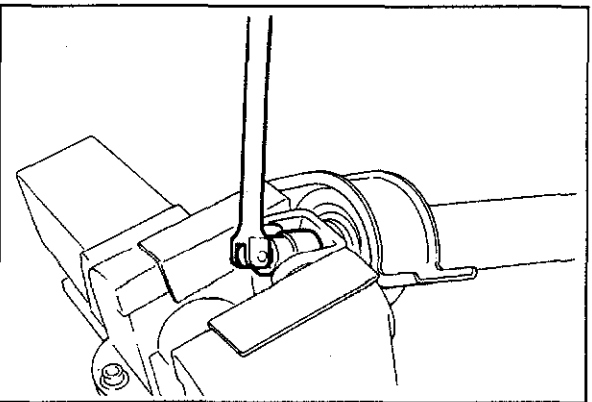

63G08X-316

**Center Yoke**

1. Make mating makes on the yoke and shaft.
2. Remove the lock nut.

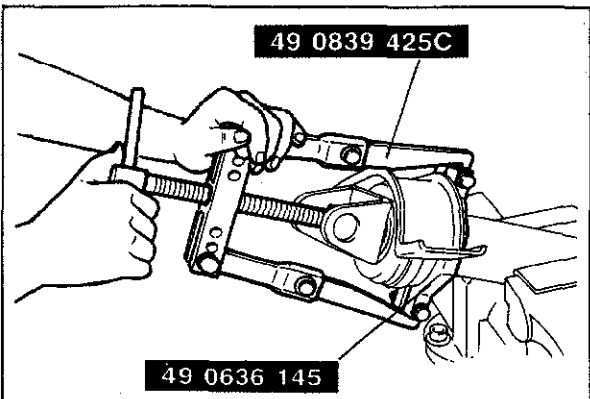

83U08X-002

3. Remove the center yoke and center bearing support assembly using **SST**.

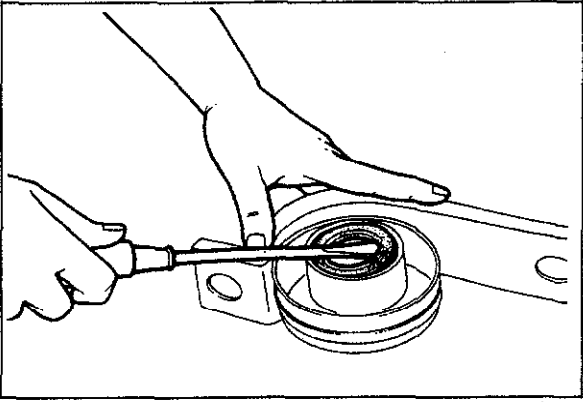

63G08X-318

## Dust Seal

Remove the dust seals.

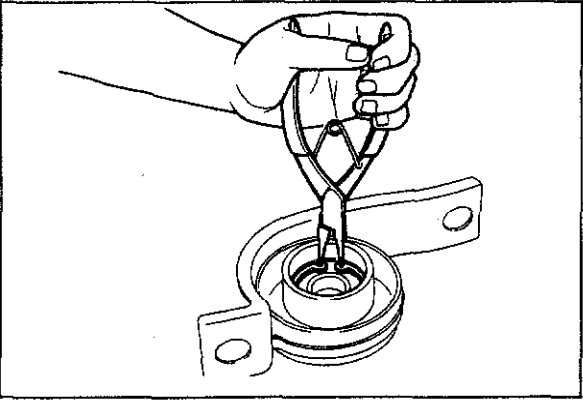

63G08X-319

## Bearing

1. Remove the snap ring using snap ring pliers.

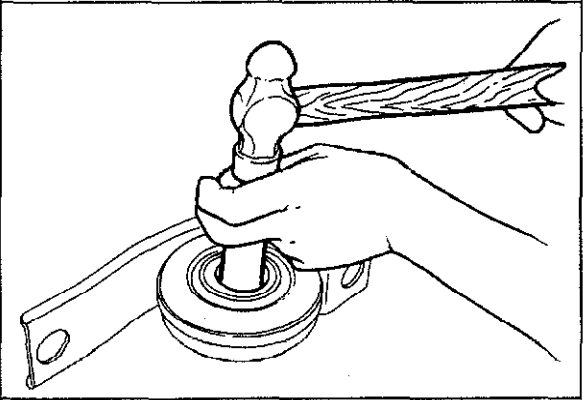

63G08X-320

2. Remove the bearing using suitable pipe.

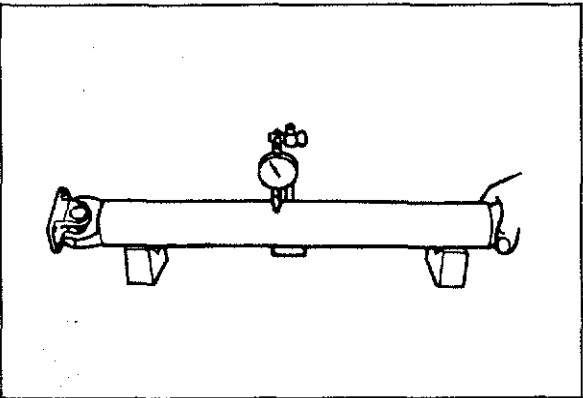

63G08X-321

## INSPECTION

Check the following points. If a problem is found replace the necessary part.

1. Runout of propeller shaft .

**Runout limit: 0.4 mm (0.016 in)**



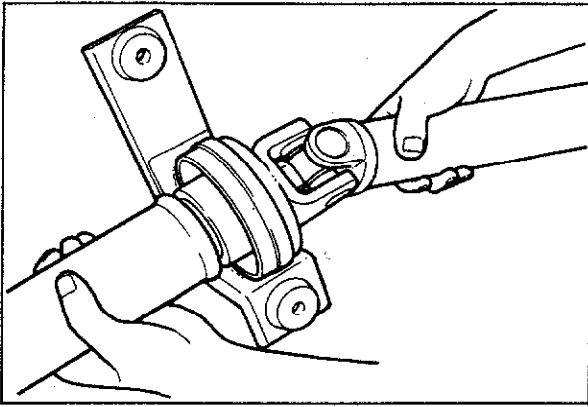

83U08X-003

2. Axial and perpendicular backlash of the universal joint.
3. Condition of universal joint operation.

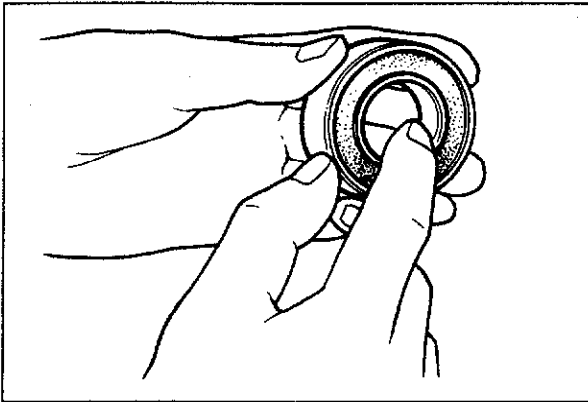

63G08X-323

4. Turn the bearing while applying force in both directions to the inner race and check for binding or abnormal noise.

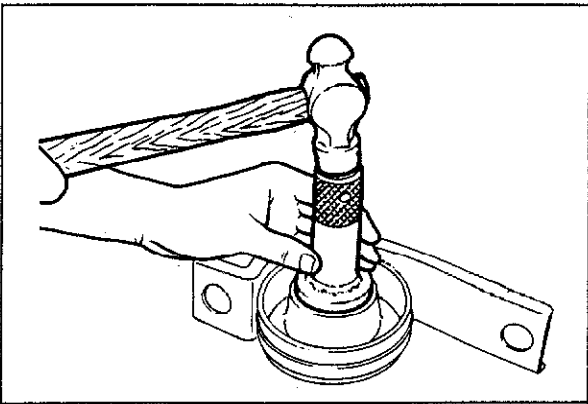

63G08X-324

## ASSEMBLY

Assemble in the reverse order of disassembly.

### Bearing

1. Install the bearing using suitable pipe.
2. Install the snap ring using snap ring pliers.

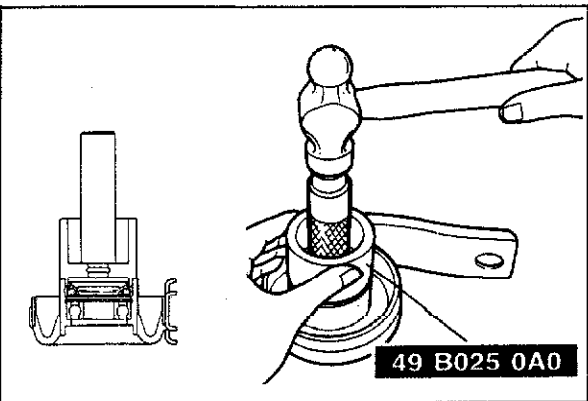

83U08X-004

### Dust Seal

1. Install the dust seal (rear and front side) using **SST**.

### Note

**Apply a coat of grease to the lip.**

(Rear seal)

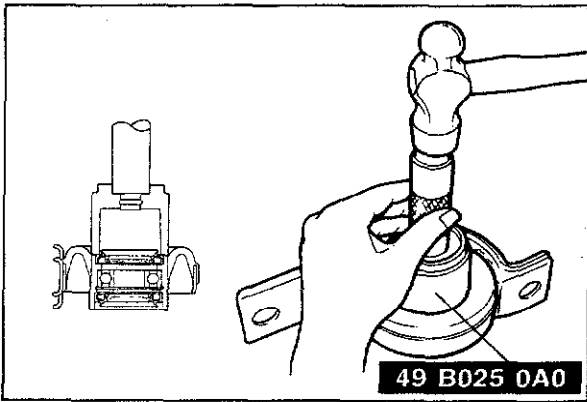

63G08X-326

(Front seal)

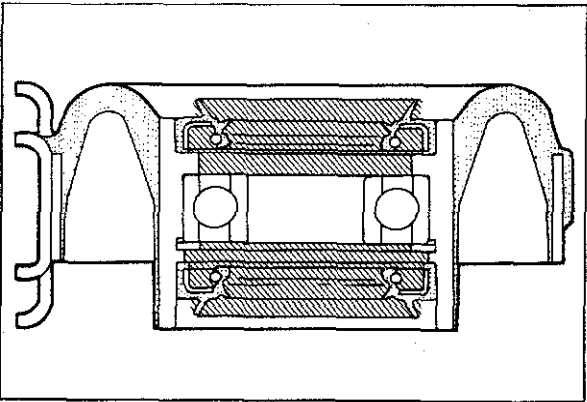

63G08X-327

2. Apply grease (lithium base, NLGI No. 2) to the area indicated by the oblique lines.

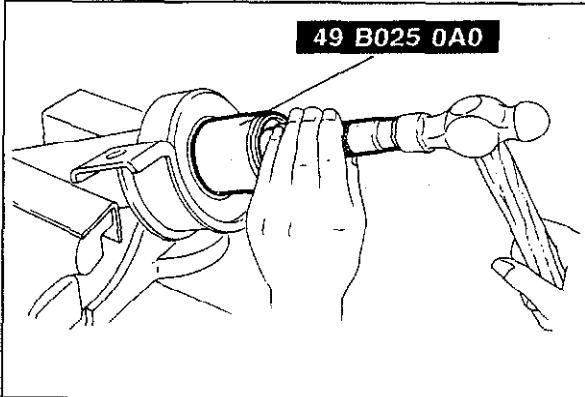

83U08X-005

### Center Bearing Support Assembly

Install the center bearing support assembly using SST.

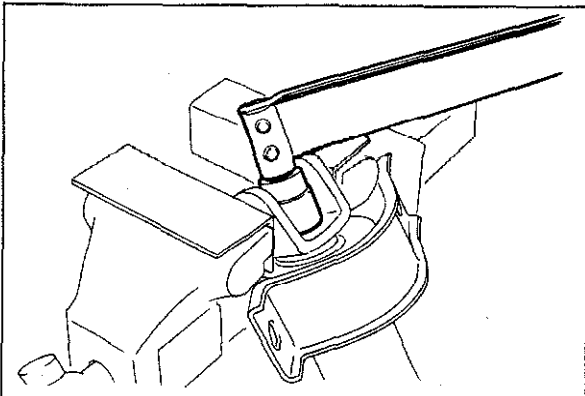

63G08X-329

### Center Yoke

1. Align the matching marks on the yoke and shaft.
2. Install the center yoke.

**Tightening torque: 157—177 N·m  
(16—18 m·kg, 116—130 ft·lb)**

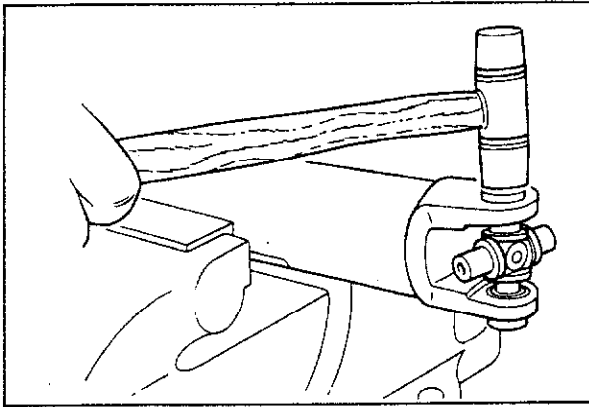

63G08X-330

### Spider

1. Before assembly, coat the inside of the bearing cup and roller and the grease hole of the spider with grease (lithium base, NLGI No. 2).
2. While in a vise, set 2 bearings in the propeller shaft, and tap them in using a plastic hammer.

### Caution

**Align the propeller shaft and spider matching marks.**

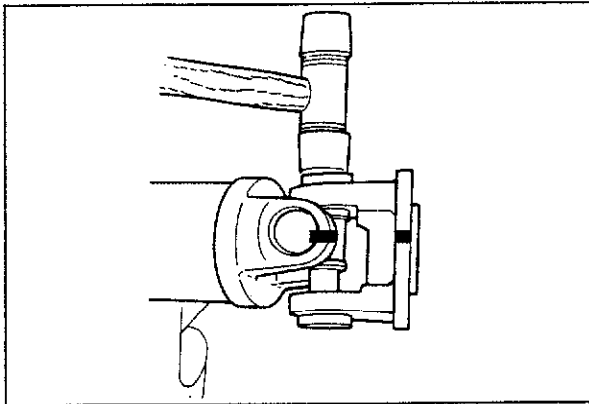

63G08X-331

### Center Yoke

1. Place the center yoke on the propeller shaft and tap the bearing into the center yoke using a plastic hammer.

### Caution

**Align the spider and yoke mating marks.**

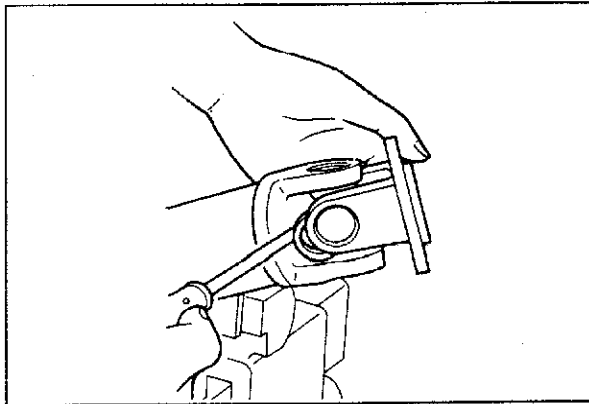

63G08X-332

2. Install new snap rings.

### Caution

- a) The snap rings cannot be re-used.
- b) All 4 snap rings must be the same thickness.
- c) Check that each snap ring fits correctly into the groove.
- d) Select the snap rings so that the universal joint starting torque will be as specified.

**Starting torque: 0.294—0.784 N·m  
(3—8 cm·kg, 2.6—6.9 in·lb)**

### Snap ring thicknesses (9 types)

1.22 mm (0.0480 in)	1.28 mm (0.0504 in)	1.34 mm (0.0528 in)
1.24 mm (0.0488 in)	1.30 mm (0.0512 in)	1.36 mm (0.0535 in)
1.26 mm (0.0496 in)	1.32 mm (0.0520 in)	1.38 mm (0.0543 in)

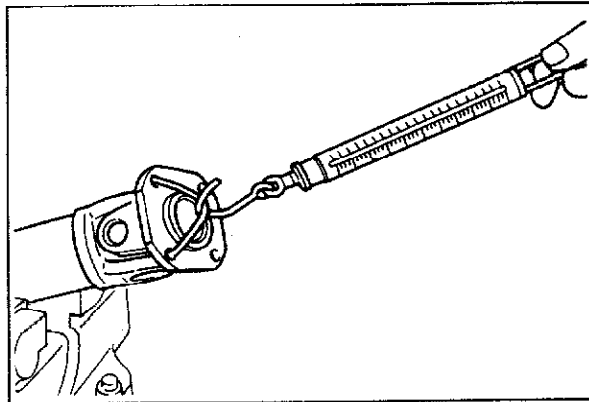

63G08X-333

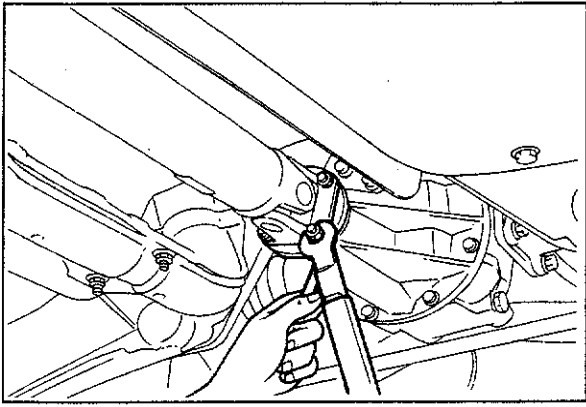

63G08X-334

## INSTALLATION

Install in the reverse order of removal.

1. Align the matching marks on the companion flange of differential and yoke.
2. Install the rear of propeller shaft.

**Tightening torque: 27—30 N·m  
(2.8—3.1 m·kg, 20—22 ft·lb)**

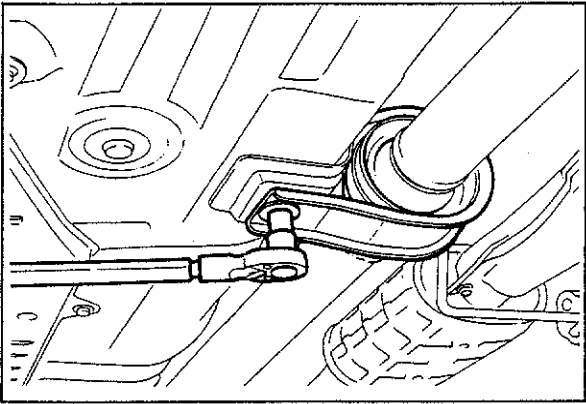

63G08X-335

3. Install the center bearing support assembly.

**Tightening torque: 37—52 N·m  
(3.8—5.3 m·kg, 27—38 ft·lb)**

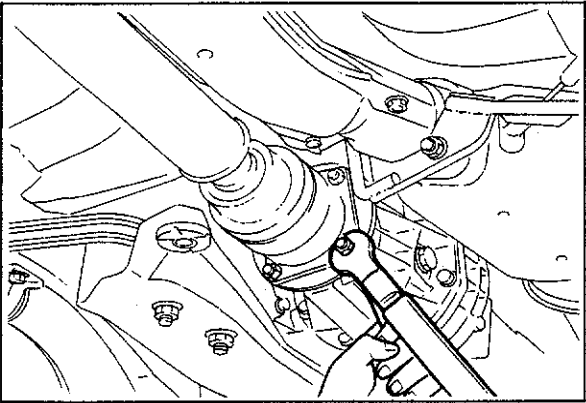

63G08X-336

4. Align the mating marks on the companion flange of the transfer unit and yoke, and install the front of propeller shaft.

**Tightening torque: 27—30 N·m  
(2.8—3.1 m·kg, 20—22 ft·lb)**

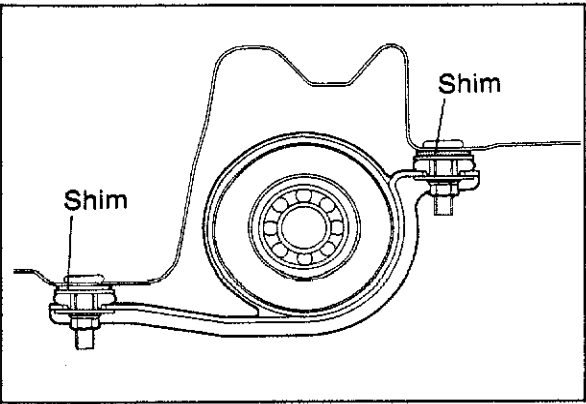

63G08X-337

5. Check that the front and rear propeller shafts are aligned. If not, adjust the height of center bearing support with shims.

### Shim thicknesses

1.6 mm (0.0630 in)	4.5 mm (0.1772 in)
3.2 mm (0.1260 in)	6.0 mm (0.2362 in)

**Note:**  
**Both shims must be the same thickness.**

# FRONT AND REAR AXLES

## 2WD/4WD

<b>OUTLINE</b> .....	9- 2
STRUCTURAL VIEW .....	9- 2
SPECIFICATIONS .....	9- 5
<b>TROUBLESHOOTING GUIDE</b> .....	9- 6
<b>ON-VEHICLE MAINTENANCE</b> .....	9- 7
DRIVESHAFT .....	9- 7
FRONT AXLE .....	9- 8
REAR AXLE .....	9- 9
<b>DRIVESHAFT</b> .....	9-10
REMOVAL .....	9-10
JOINTSHAFT .....	9-13
DISASSEMBLY (Turbo) .....	9-14
INSPECTION (Turbo) .....	9-16
ASSEMBLY (Turbo) .....	9-16
DISASSEMBLY (Non-Turbo) .....	9-18
INSPECTION (Non-Turbo) .....	9-19
ASSEMBLY (Non-Turbo) .....	9-20
INSTALLATION .....	9-21
<b>FRONT AXLE</b> .....	9-23
REMOVAL .....	9-23
DISASSEMBLY .....	9-24
INSPECTION .....	9-25
ASSEMBLY .....	9-26
INSTALLATION .....	9-29
<b>REAR AXLE</b> .....	9-30
REMOVAL (DRUM BRAKE) .....	9-30
REMOVAL (DISC BRAKE) .....	9-31
INSPECTION .....	9-32
INSTALLATION .....	9-33

## 4WD

<b>OUTLINE</b> .....	9-36
OUTLINE OF CONSTRUCTION .....	9-36
STRUCTURAL VIEW .....	9-36
SPECIFICATIONS .....	9-40
<b>TROUBLESHOOTING GUIDE</b> .....	9-40
<b>REAR DIFFERENTIAL</b> .....	9-42
ON-VEHICLE CHECK .....	9-42
ON-VEHICLE MAINTENANCE .....	9-42
REMOVAL .....	9-47
DISASSEMBLY .....	9-49
INSPECTION .....	9-53
ASSEMBLY .....	9-54
INSTALLATION .....	9-62
<b>REAR DRIVESHAFT</b> .....	9-64
ON-VEHICLE CHECK .....	9-64
REMOVAL AND INSTALLATION .....	9-65
DISASSEMBLY AND ASSEMBLY .....	9-66
<b>REAR AXLE</b> .....	9-67
ON-VEHICLE CHECK .....	9-67
REMOVAL AND INSTALLATION .....	9-68
DISASSEMBLY .....	9-70
INSPECTION .....	9-72
ASSEMBLY .....	9-73

## 2WD/4WD OUTLINE

### STRUCTURAL VIEW Driveshaft (Turbo)

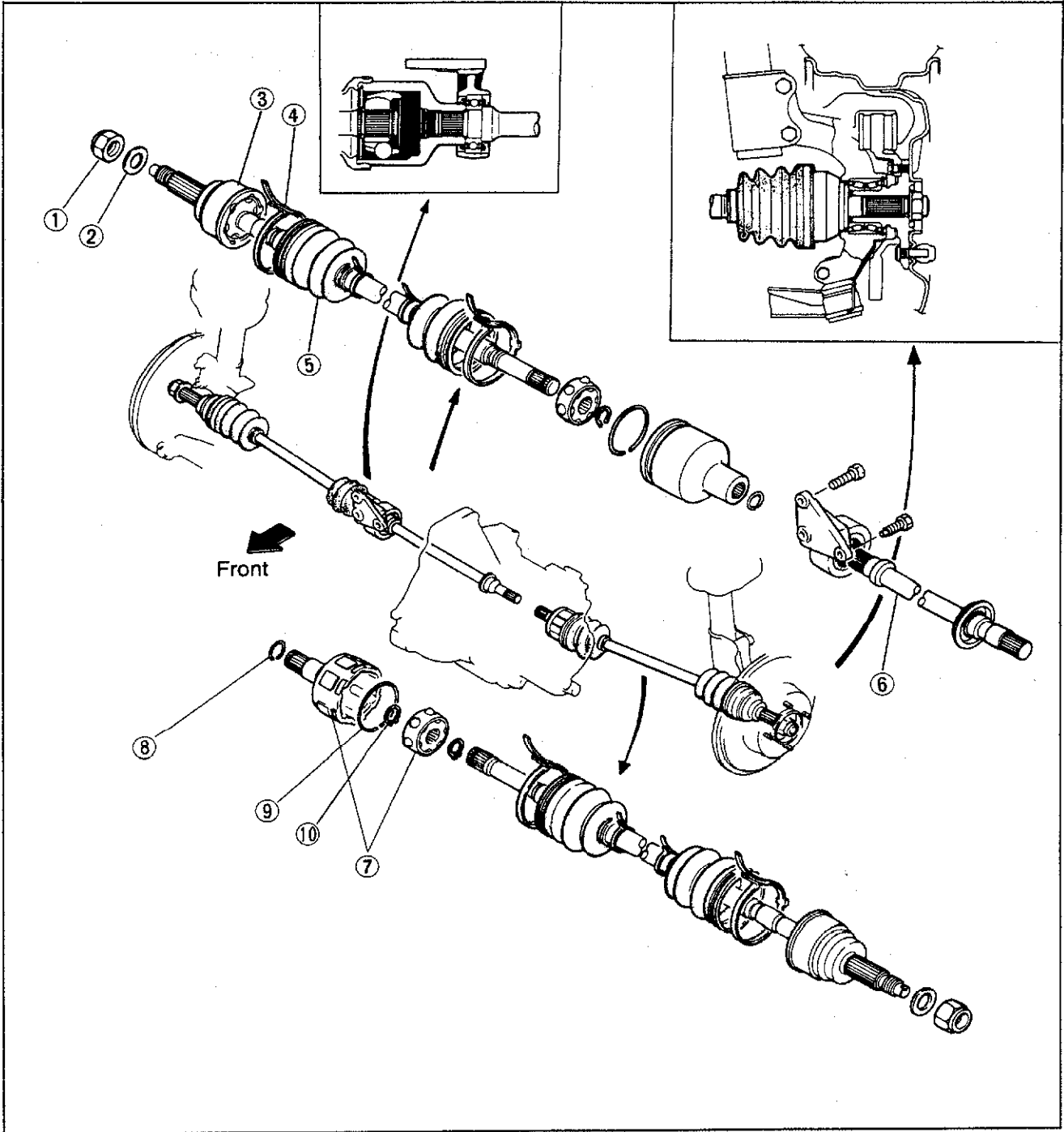

83U09X-002

- 1. Locknut
- 2. Washer
- 3. Ball joint (wheel side)
- 4. Boot band
- 5. Boot

- 6. Dynamic damper (right side only)
- 7. Ball joint assembly (differential side)
- 8. Clip
- 9. Clip
- 10. Snap ring

Driveshaft (Non-Turbo)

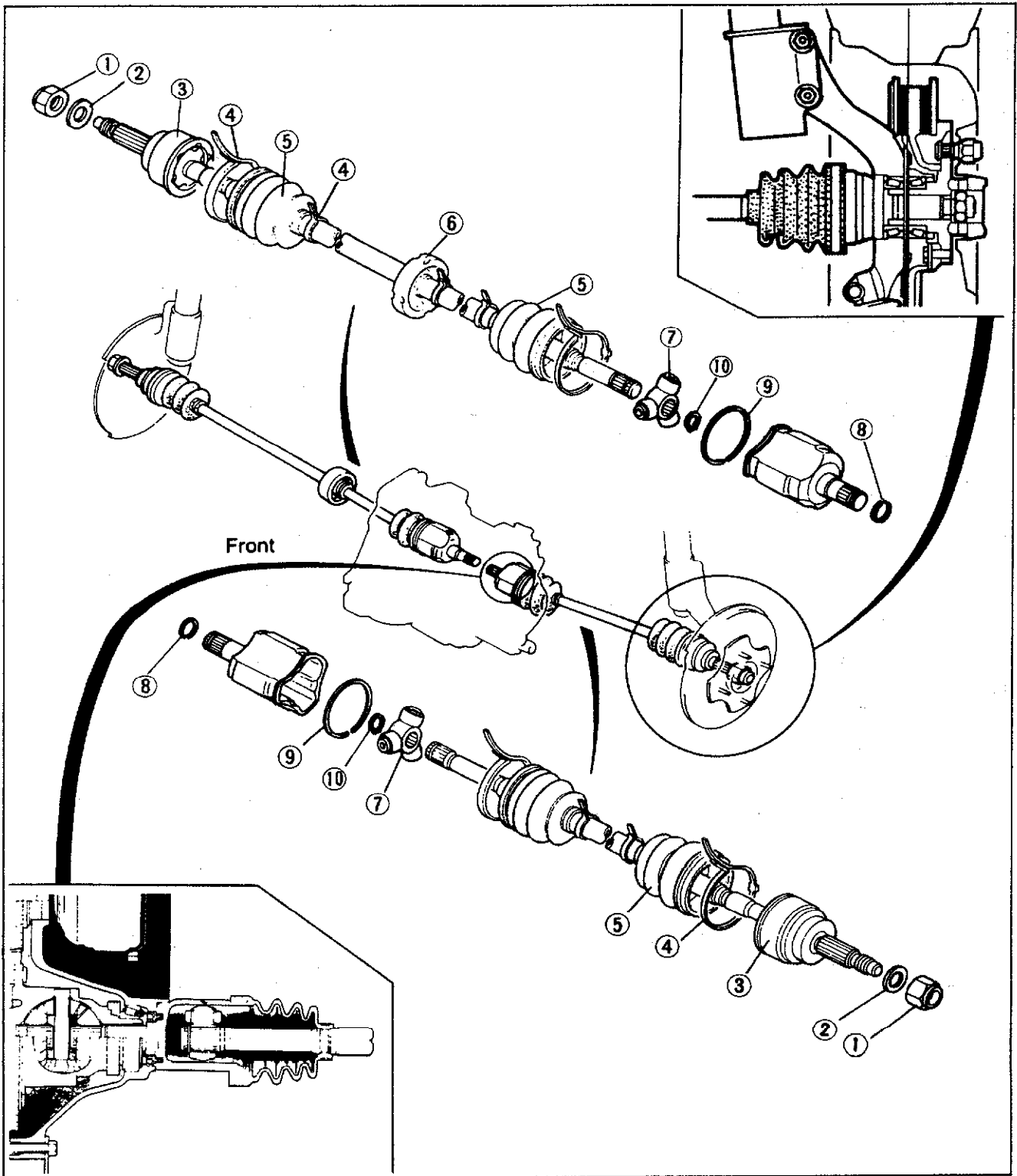

83U09X-003

- 1. Locknut
- 2. Washer
- 3. Ball joint (wheel side)
- 4. Boot band
- 5. Boot

- 6. Dynamic damper (right side only)
- 7. Tri-pod joint (differential side)
- 8. Clip
- 9. Clip
- 10. Snap ring

## Front Axle

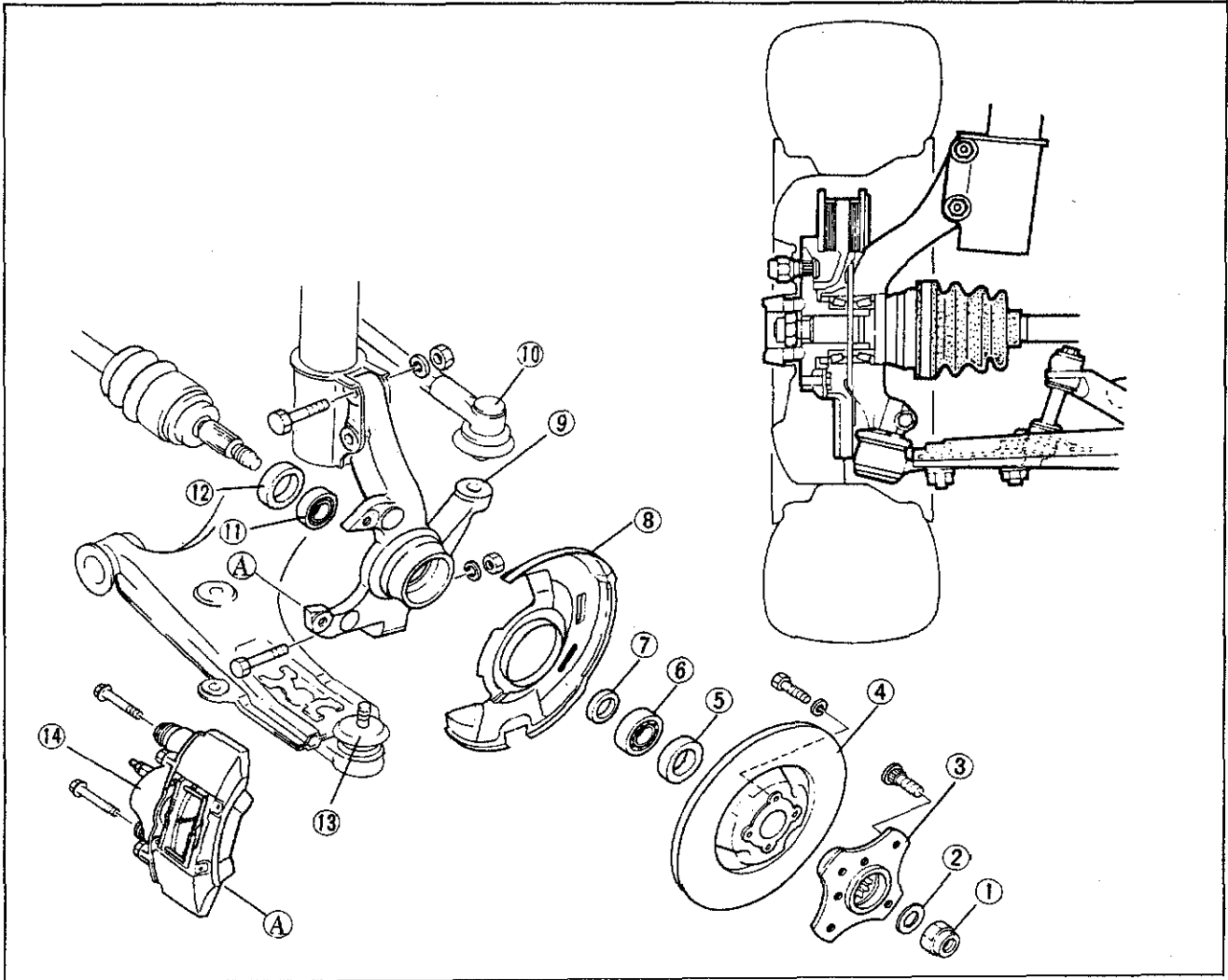

63U09X-004

- |                   |                        |                              |
|-------------------|------------------------|------------------------------|
| 1. Lock nut       | 6. Outer wheel bearing | 11. Inner wheel bearing      |
| 2. Washer         | 7. Spacer              | 12. Inner oil seal           |
| 3. Wheel hub      | 8. Dust cover          | 13. Lower arm ball joint     |
| 4. Disc plate     | 9. Knuckle             | 14. Caliper and pad assembly |
| 5. Outer oil seal | 10. Tie-rod end        |                              |



Rear Axles

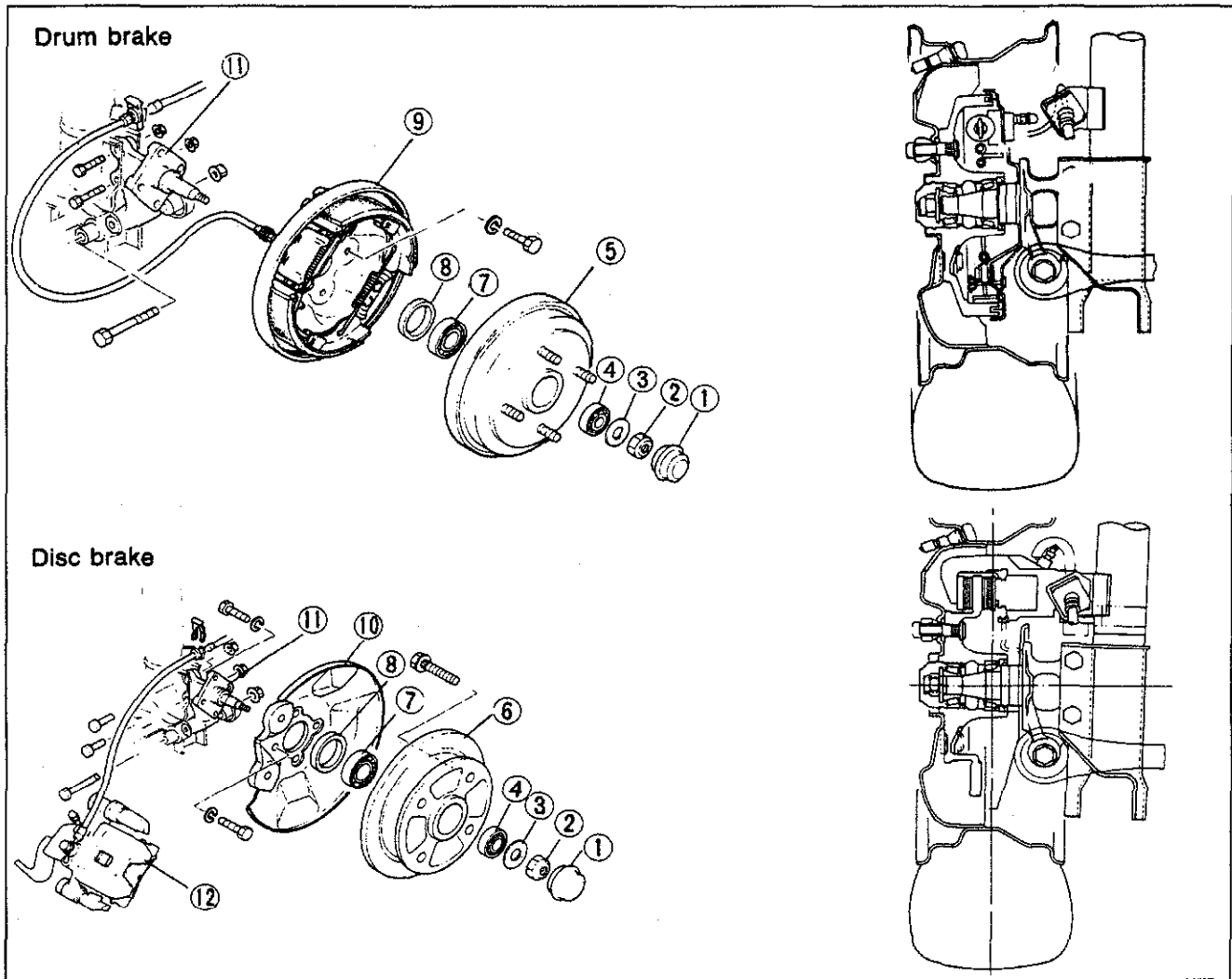

63U09X-005

- |                          |                          |                              |
|--------------------------|--------------------------|------------------------------|
| 1. Hub cap               | 5. Brake drum            | 9. Back plate                |
| 2. Lock nut              | 6. Disc plate            | 10. Dust cover               |
| 3. Washer                | 7. Wheel bearing (inner) | 11. Spindle                  |
| 4. Wheel bearing (outer) | 8. Oil seal              | 12. Caliper and pad assembly |

SPECIFICATIONS

Item	Engine type		B6 EGI	B6 DOHC	
				2WD	4WD
Length of driveshaft	ATX	Right side mm (in)	907.7 (35.74)	—	—
		Left side mm (in)	628.7 (24.75)	—	—
	MTX	Right side mm (in)	907.5 (35.73)	561.0 (22.09)	564.0 (22.20)
		Left side mm (in)	628.5 (24.74)	614.0 (24.17)	629.0 (24.76)
Driveshaft diameter		mm (in)	22.0 (0.87)	22.5 (0.89)	21.0 (0.83)
Length of jointshaft		mm (in)	—	386.9 (15.23)	384.9 (15.15)

83U09X-004

## TROUBLESHOOTING GUIDE

Problem	Possible Cause	Remedy
<b>Faulty operation of driveshaft</b>	Broken ball joint Broken tri-pod joint Worn or seized joint	Replace Replace Replace
<b>Abnormal noise from driveshaft</b>	Insufficient grease in joint or spline Excessive backlash on spline Worn joint	Replenish or replace Replace Replace
<b>Steering wheel pulls. (While driving on a straight and level road, the steering wheel pulls toward either right or left side)</b>	Incorrect front wheel bearing preload adjustment Bent steering linkage Fatigued coil spring Lower arm bushing worn or damaged Bent knuckle arm Bent lower arm or loose mounting Incorrect toe-in adjustment Improper tire air pressure Unevenly worn tires (difference in wear between left and right tires) Brake dragging	Adjust or replace Refer to Section 10 Refer to Section 13 Refer to Section 13 Replace Refer to Section 13 Refer to Section 13 Refer to Section 12 Refer to Section 12 Refer to Section 11
<b>Unstable handling</b>	Incorrect wheel bearing preload adjustment Bent steering linkage Joint in steering system worn or damaged Incorrect steering pinion preload adjustment Fatigued coil spring Faulty shock absorbers Lower arm bushing worn or damaged Incorrect toe-in adjustment (front or rear) Improper tire air pressure Wheels bent or unbalanced	Adjust or replace Refer to Section 10 Refer to Section 10 Refer to Section 10 Refer to Section 13 Refer to Section 13 Refer to Section 13 Refer to Section 13 Refer to Section 12 Refer to Section 12
<b>Excessive steering wheel play</b>	Faulty front wheel bearing Incorrect steering pinion preload adjustment Rack and pinion worn Joint in steering system worn or damaged Lower arm bushing worn or damaged	Adjust Refer to Section 10 Refer to Section 10 Refer to Section 10 Refer to Section 13
<b>Tires excessively worn or worn unevenly</b>	Incorrect wheel bearing preload adjustment (excessively loose) Incorrect toe-in adjustment Improper tire air pressure Unbalanced wheel(s)	Adjust Refer to Section 13 Refer to Section 12 Refer to Section 12
<b>Abnormal noise from axle</b>	Faulty wheel bearing	Replace

83U09X-005

## ON-VEHICLE MAINTENANCE

### DRIVESHAFT

#### Boot

Check the boots on the driveshaft for cracks, damage, leaking grease or loose boot bands. If any damage is found, replace the boot.

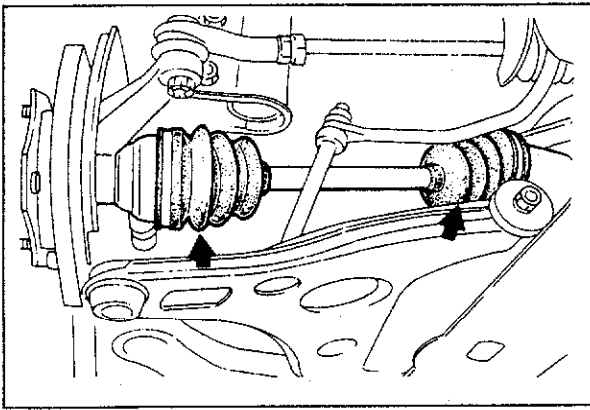

83U09X-006

#### Spline Looseness

Turn the driveshaft by hand and make sure the spline and joint are not excessively loose. If damage is found or joint is loose, replace or repair.

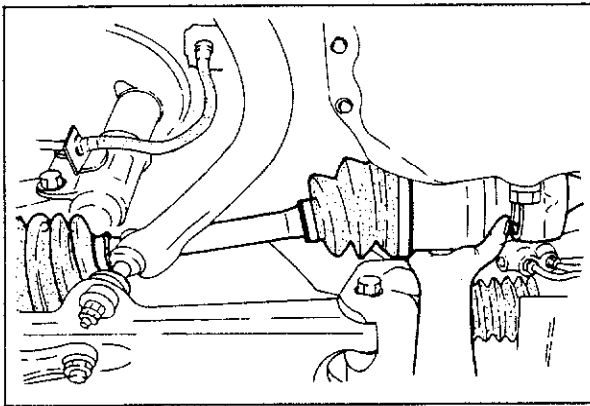

83U09X-007

#### Twisted or Cracked

Make sure the driveshaft is not twisted or cracked. Replace if necessary.

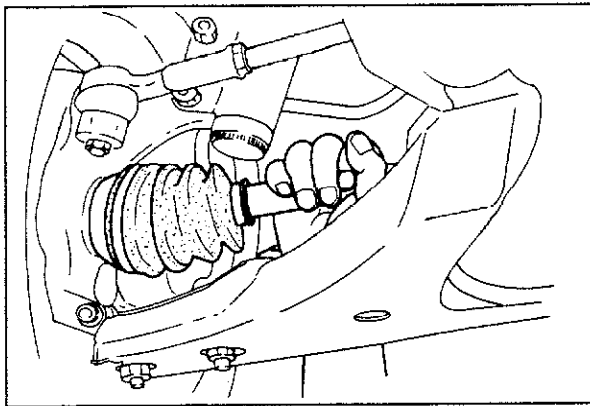

83U09X-008

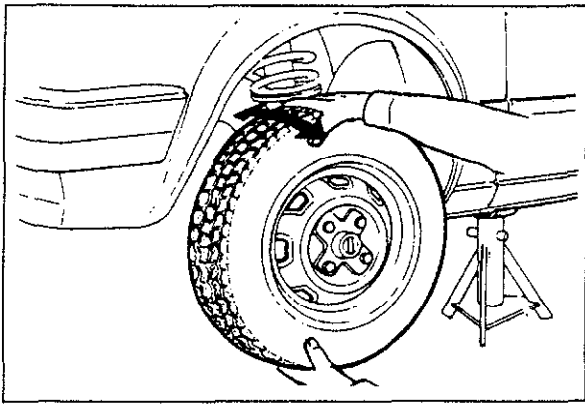

63U09X-011

## FRONT AXLE Wheel Bearing End Play

1. Raise the front of the vehicle and check for loose front wheel bearings by rocking the tires at the top and bottom.

**End play: 0 mm (0 in)**

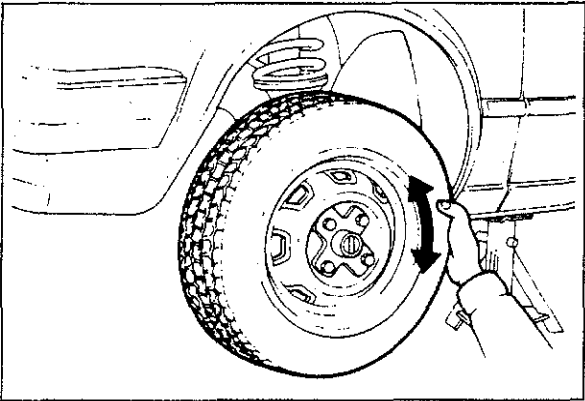

83U09X-009

2. Spin the tire quickly by hand and make sure the tire turns smoothly with no abnormal noise from the bearing.

### Note

**Take care not to be confused by the looseness of the lower arm ball joint.**

**If any abnormal looseness or noise is found, disassemble the hub and knuckle and adjust the preload.**

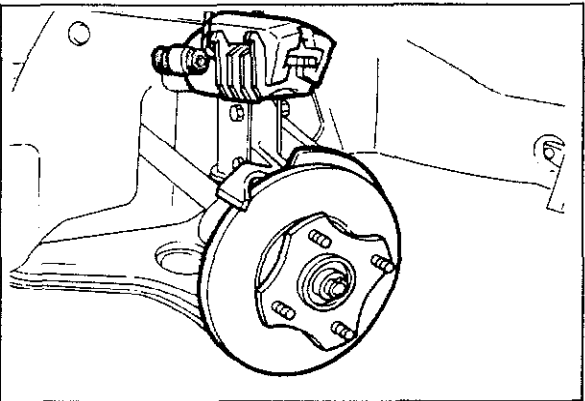

63U09X-013

3. Remove the wheel, and remove the front disc caliper assembly and hang it from the shock absorber.

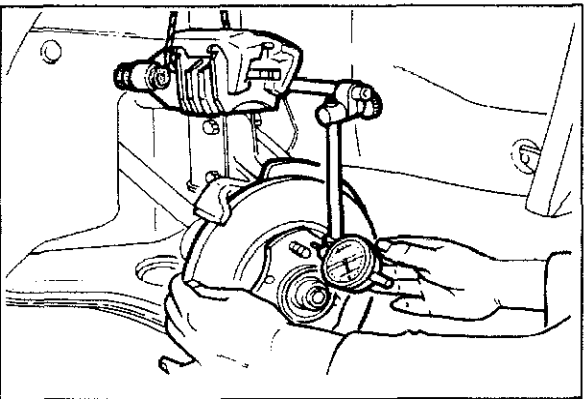

83U09X-010

4. Set a dial gauge against the wheel hub, then push and pull the wheel hub in the axial direction and measure the axial play of the wheel bearing. If the play exceeds the specified limit, adjust the preload or replace the bearing.

**Axial play: 0 mm (0 in)**

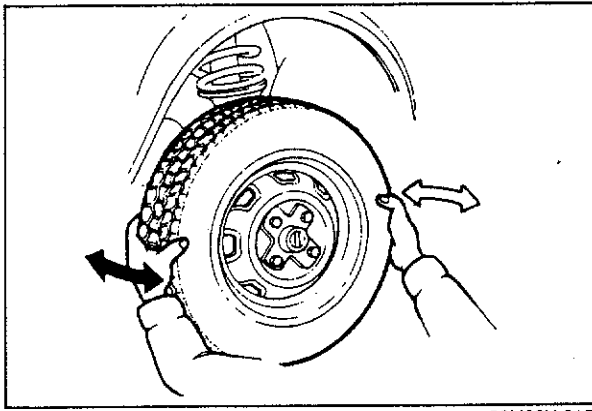

63U09X-015

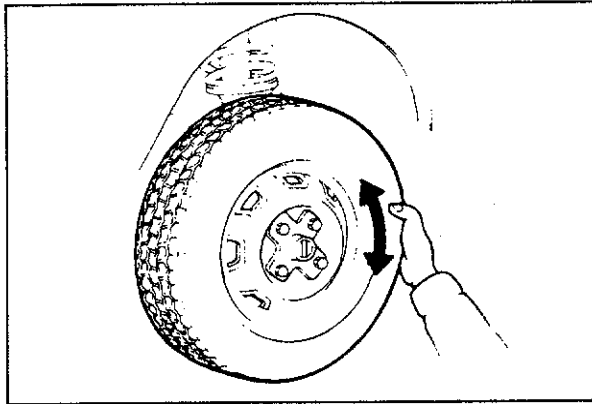

83U09X-011

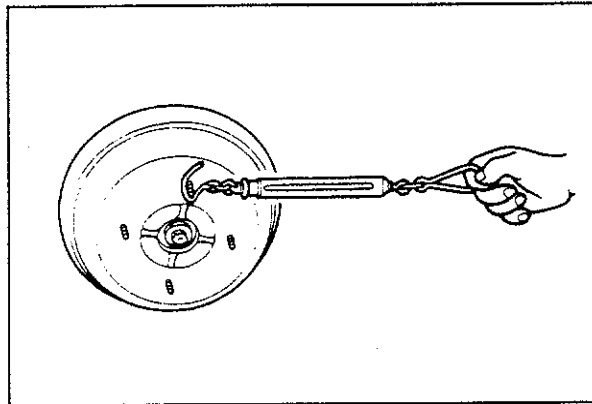

83U09X-012

## REAR AXLE

### Wheel Bearing End Play

1. Jack up the rear of the vehicle and support it with safety stands. Rock the tire by hand and confirm that there is no bearing play.

**Wheel bearing axial play: 0 mm (0 in)**

2. Spin the tire quickly by hand, and confirm that it spins smoothly and that there is no abnormal noise from the bearing.

If any problem is found, adjust or replace the bearing.

### Bearing Preload

1. Remove the wheel and tire.
2. Hook a spring scale on a hub bolt and measure the torque at which the hub begins to rotate.

#### Note

**Make sure the brakes are not dragging.**

**Bearing preload (Rotation starting torque):**

**0.15—0.49 N·m**

**(1.5—5 cm·kg, 0.11—0.36 ft·lb)**

**2.6—8.5 N (0.26—0.87 kg, 0.57—1.91 lb)**

If the preload is not within specification, adjust it.

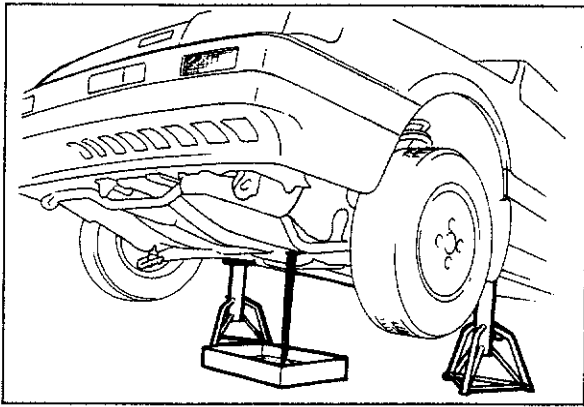

63U09X-018

## DRIVESHAFT

### REMOVAL

1. Jack up the front of the vehicle and support it with safety stands.
2. Drain the transaxle oil.
3. Remove the front wheels.
4. Remove the side covers.

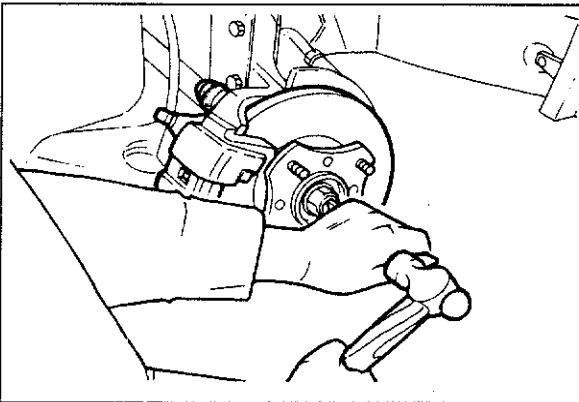

63U09X-019

5. Raise the nut tab and loosen the driveshaft lock-nut, but do not remove it.

### Note

**When loosening the nut, lock the hub by applying the brakes.**

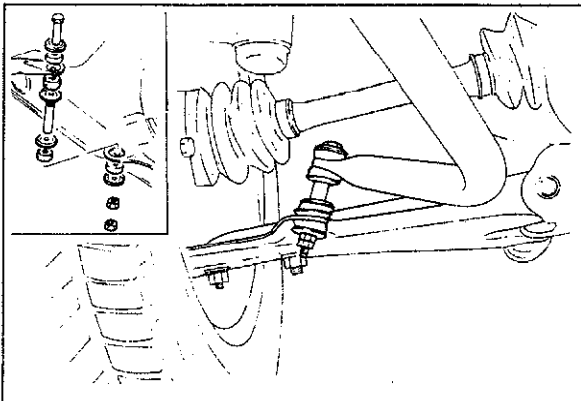

63U09X-020

6. Remove the stabilizer bar control link from the lower arm (only MTX).

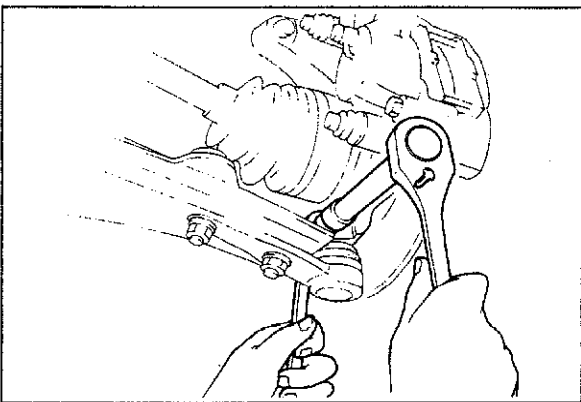

63U09X-021

7. Remove the clamp bolt and nut.

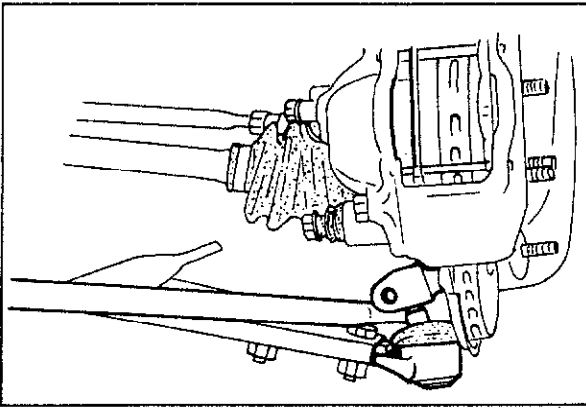

63U09X-022

8. Pry down the lower arm and disconnect the ball joint.

**Note**

**Be careful not to damage the ball joint dust boot.**

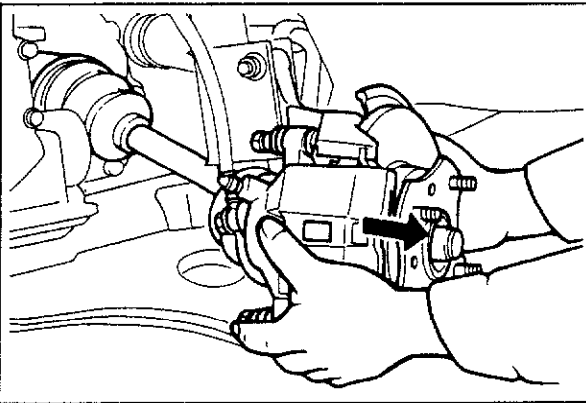

63U09X-023

9. Separate the driveshaft from the transaxle.

**MTX**

Separate the shaft by pulling the hub outward. Make sure not to use too much force at once, increase the force gradually. (If the shaft is pulled out too quickly, the oil seal may be damaged.)

If it is difficult to separate, do as follows:

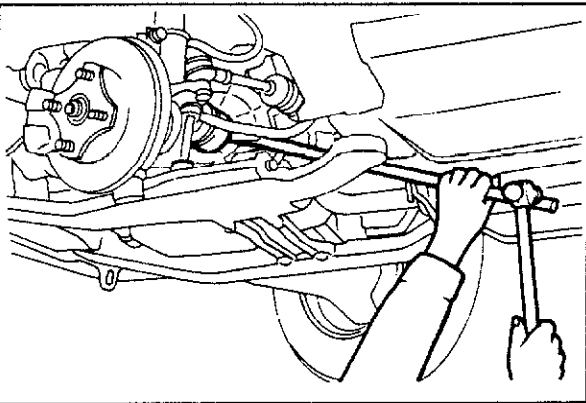

63U09X-024

Insert a bar between the driveshaft and the transaxle case as shown in the figure, lightly tap the end of the bar.

**Note**

**Do not insert the bar too far in between the shaft and the case; doing so might damage the lip of the oil seal.**

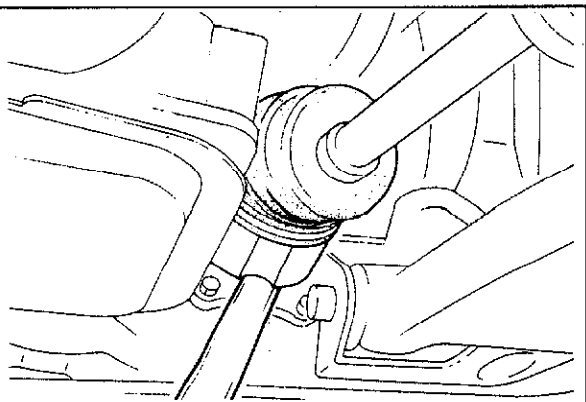

63U09X-025

**ATX**

Do not pull the hub outward as for the MTX.

Insert a bar between the drive shaft and the bearing housing, and tap the end of the bar.

**Note**

**Do not insert the bar too far in between the shaft and the housing; doing so might damage the lip of the oil seal.**

# 9 DRIVESHAFT

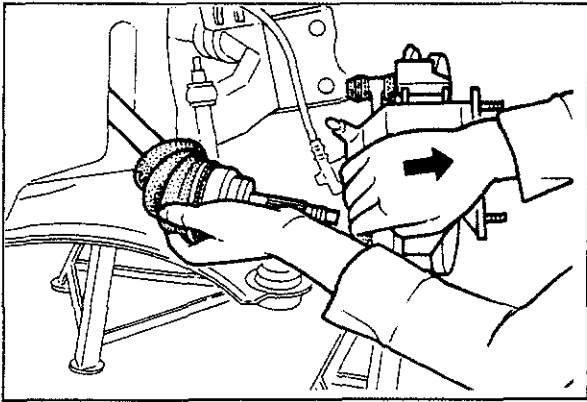

83U09X-026

10. Remove the driveshaft lock nut.
11. Pull the driveshaft out of the wheel hub.

### Note

Be especially careful not to damage the oil seal at this time.

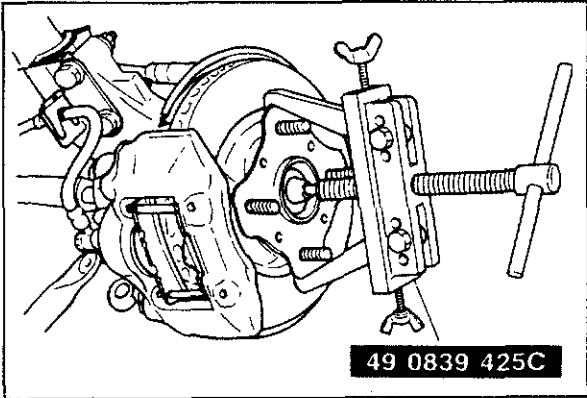

83U09X-024

If the driveshaft is stuck to the front hub and cannot be removed, use the **SST** to push the shaft out.

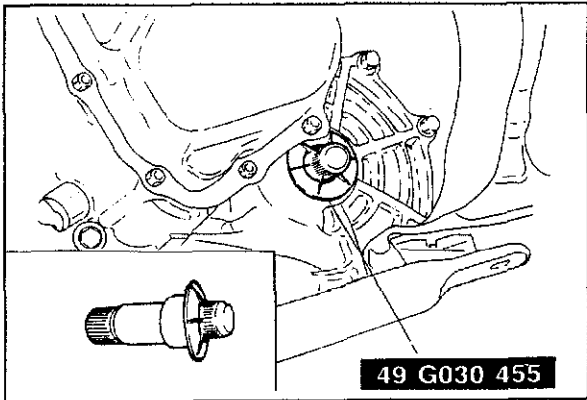

83U09X-025

12. Pull the driveshaft out of the transaxle.
13. After removing the driveshaft, install the **SST** the transaxle, thus preventing dirt from getting into the transaxle.

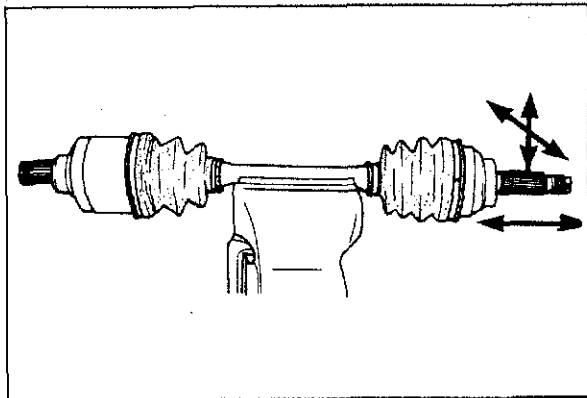

83U09X-013

14. Before disassembling the driveshaft, make sure the joint moves smoothly in the direction indicated by the arrows.  
If a problem is found, replace the parts.



## JOINTSHAFT

### Disassembly and Assembly

Disassemble in the sequence shown in the figure.

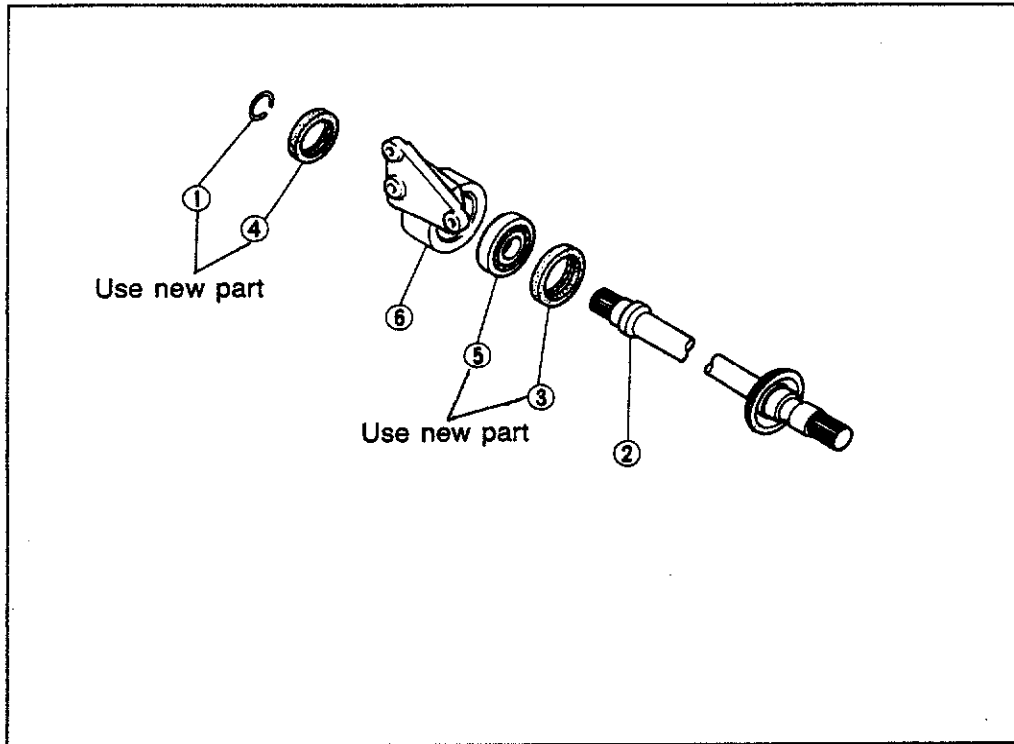

1. Clip
2. Joint shaft
3. Oil seal
4. Oil seal
5. Bearing
6. Bracket

83U09X-014

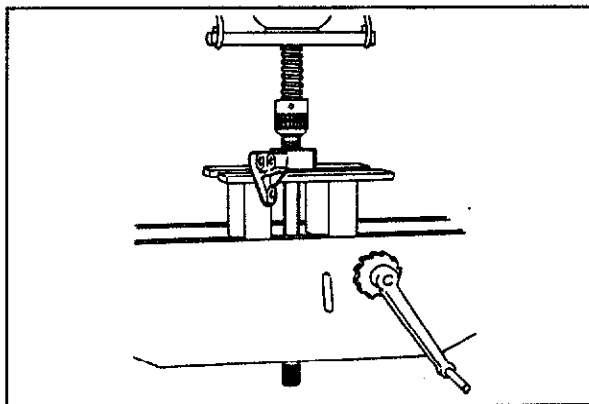

63G09X-312

### Jointshaft

Support the bearing and remove the jointshaft, using a press.

### Caution

**Hold the shaft by hand, do no let it drop.**

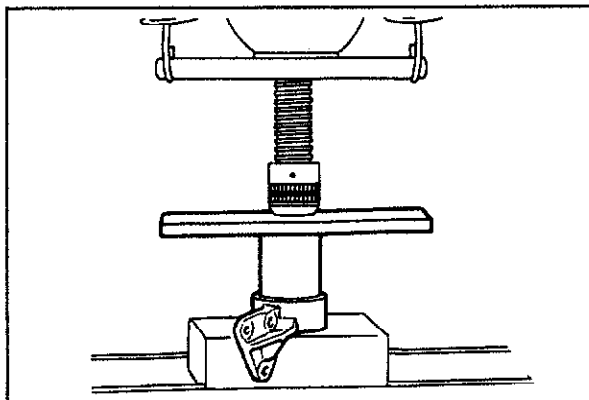

63G09X-313

### Bearing

Support the bracket and remove the bearing using a press.

# 9 DRIVESHAFT

## DISASSEMBLY (Turbo)

Disassemble in the order shown.

### Note

- a) Clamp the shaft in a vice. Use wood in the vice to avoid damage.
- b) Do not allow dust or foreign matter to enter the joint during disassembly or assembly.
- c) Do not disassemble the ball joint at the wheel side. Do not wipe off the grease if there is no problem.
- d) Do not remove the clip which is used to secure the outer ring to the ball joint at the differential side if there is no problem. If the clip is removed, replace it with a new one.

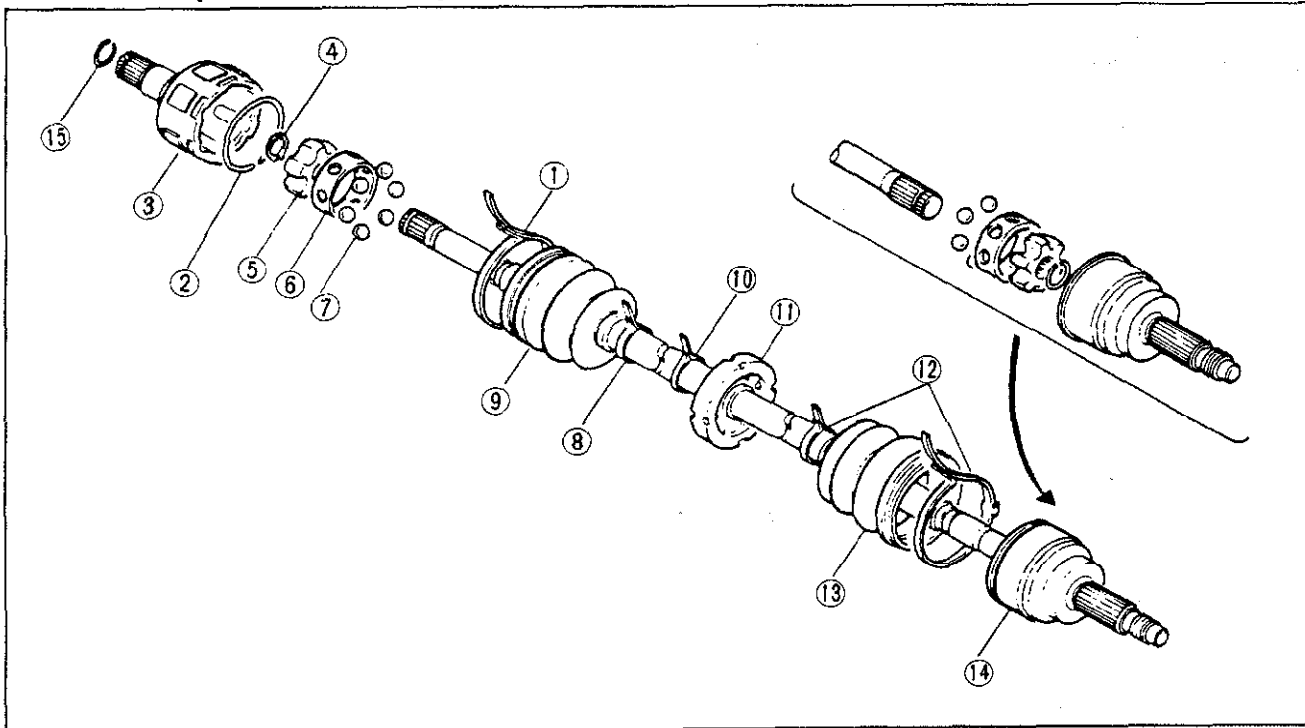

53G09X-005

- |  |                                      |
|--|--------------------------------------|
| 1. Boot band   | 8. Boot band                         |
| 2. Clip (for locking the ball joint at the differential side outer ring) | 9. Boot                              |
| 3. Outer ring  | 10. Boot band (right side only)      |
| 4. Snap ring   | 11. Dynamic damper (right side only) |
| 5. Inner ring  | 12. Boot band                        |
| 6. Cage  | 13. Boot                             |
| 7. Ball  | 14. Shaft and ball joint assembly    |
|  | 15. Clip                             |

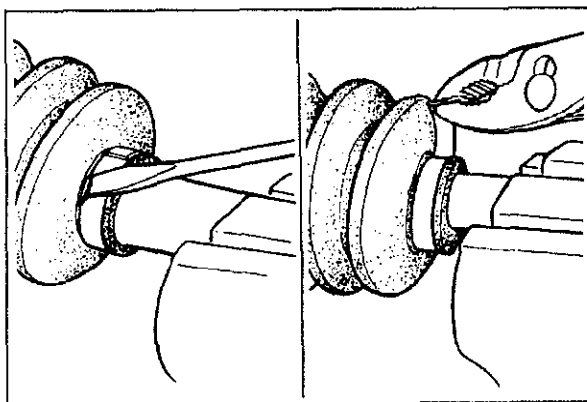

63U09X-032

### Boot Band

To remove the boot band, pry up the locking clip with a screwdriver and then raise the end of the band.

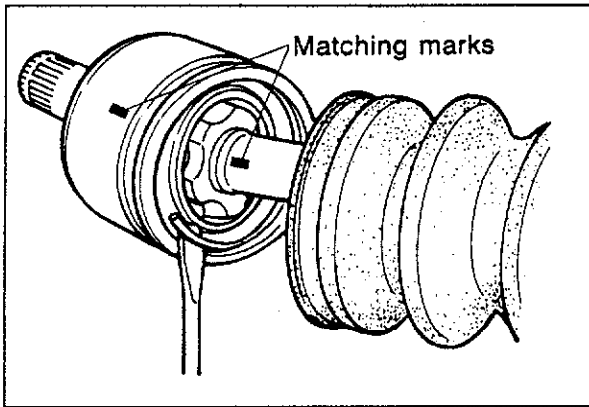

63U09X-033

### Clip

1. Make matching marks on the drive shaft and outer ring.

### Note

**Mark with paint, do not use a punch.**

2. Remove the clip with a flat-tipped screwdriver.

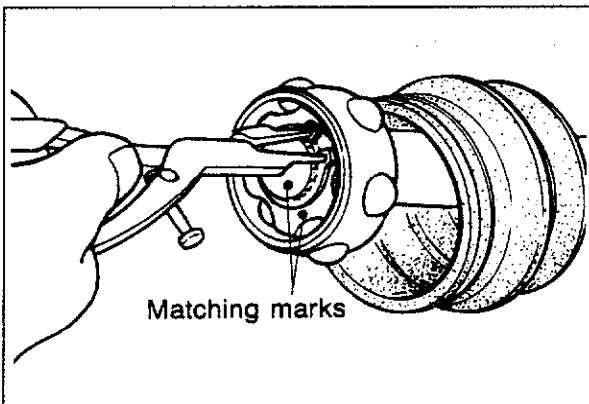

63U09X-034

### Snap Ring

1. Use a punch and make matching marks on the driveshaft end and inner ring.
2. Remove the snap ring with snap ring pliers.

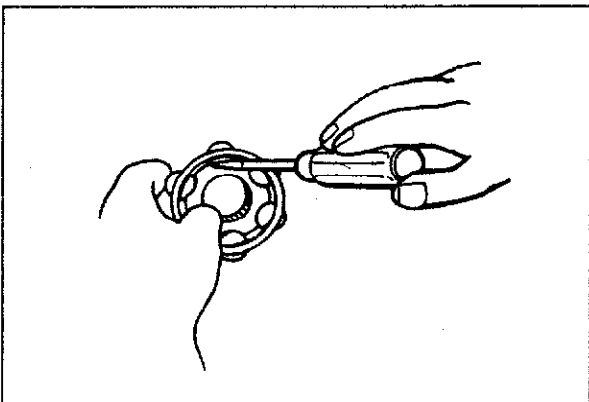

63U09X-035

### Balls, Inner ring, and Cage

Disassemble in the following order:

1. Insert a flat-tipped screwdriver between the inner ring and the cage to remove the balls.

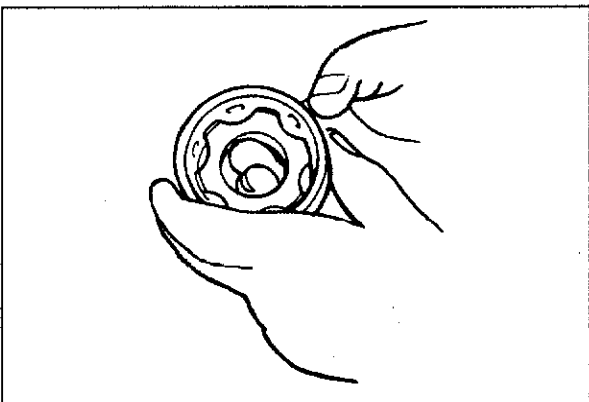

63U09X-036

2. Make matching marks on the inner ring and cage.

### Note

**Mark with paint, do not use a punch.**

3. Turn the cage approximately 30 degrees, and then pull it away from the inner ring.

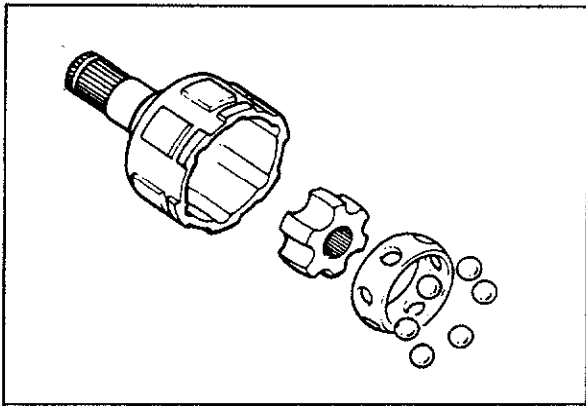

83U09X-015

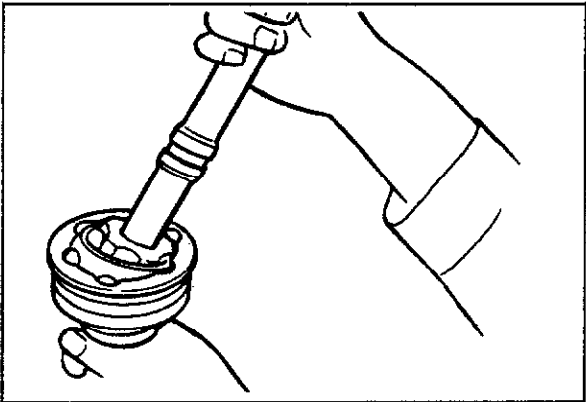

63U09X-038

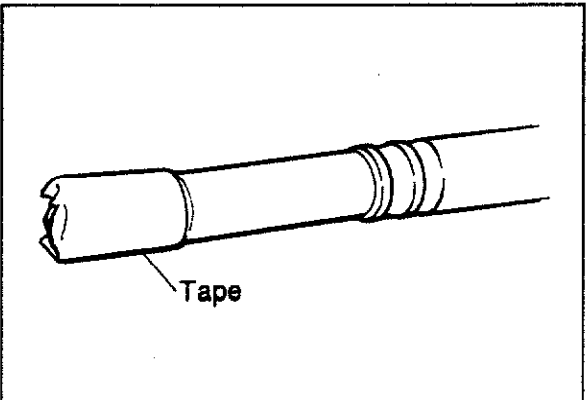

83U09X-016

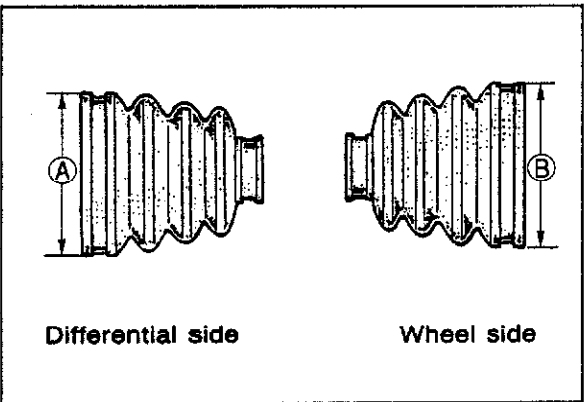

63U09X-040

## INSPECTION (Turbo)

Wash the disassembled parts, check and replace all damaged parts.

Inspect for:

1. Twisted, bent or damaged shaft.
2. Worn or scored splines.
3. Worn, rusted or damaged ball joint.
4. Excessive looseness, seizure or rust in the ball joint.
5. Inspect the boots for cracks, damage or deterioration.

## ASSEMBLY (Turbo)

Assemble in the reverse order of disassembly and note the following:

### Note

**Install dynamic damper on right hand side driveshaft before assembling joint to driveshaft.**

### Ball Joint

1. Apply the specified grease (molybdenum disulfide) to the joint. Do not use any other type of grease.

### Note

**The color of this grease is black, and it is supplied in the boot kit and joint kit.**

2. Before putting the boot onto the shaft, put tape on the shaft splines.
3. The shape of the ball joint boots at the wheel side and the differential side differ, so be careful not to install incorrectly.

	A	B
Non-Turbo	83.6 (3.29)	90.4 (3.56)
Turbo	95.5 (3.76)	92.4 (3.64)

4. Fill the ball joint at the wheel side with the same amount of specified grease that had been wiped off.

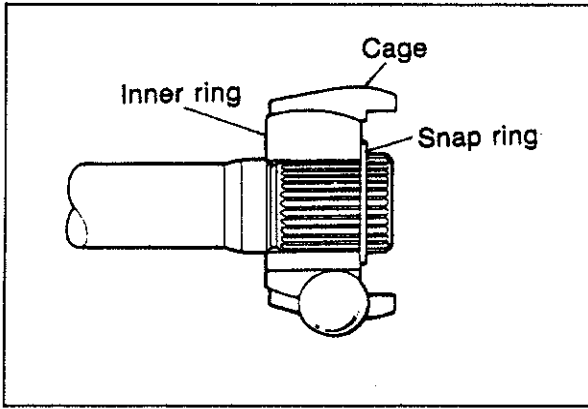

63U09X-041

5. Align the matching marks, then install the cage and inner ring on the shaft.
6. Install the snap ring.

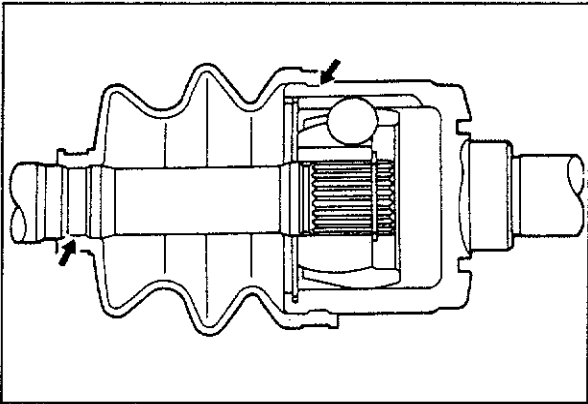

63U09X-042

7. Carefully fit the boot to the grooves in the shaft and outer ring.

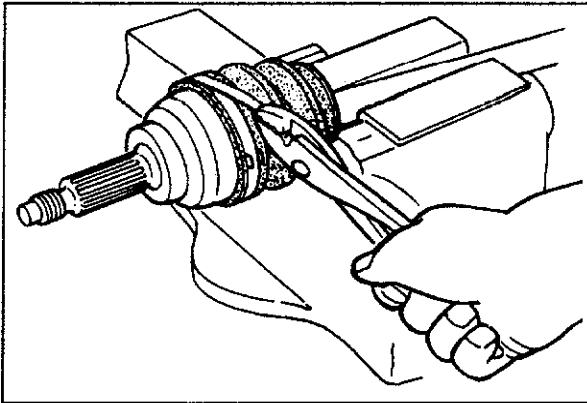

63U09X-043

### Boot Band

Tighten the boot band according to the following procedure:

#### Note

- a) Always use a new band.
- b) The band should be folded in the direction opposite to the forward revolving direction of the driveshaft.

1. Fold the band back by pulling on the end of the band with pliers.
2. Lock the end of the band by bending the locking clip.

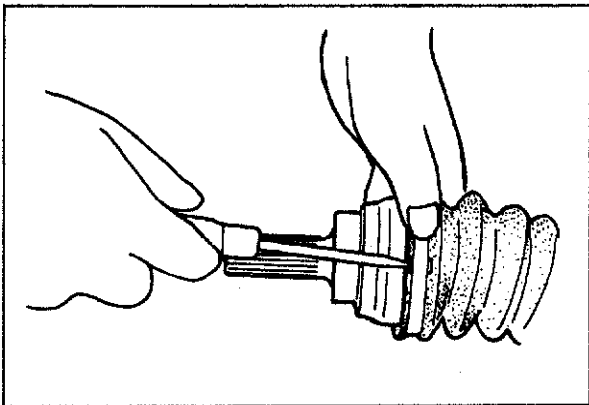

63U09X-044

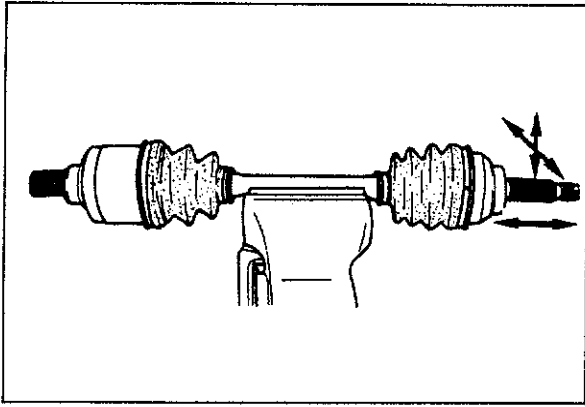

63U09X-045

After assembling the driveshaft, check the following parts:

1. Make sure the joint parts move smoothly in the direction indicated by the arrows.
2. Check for grease leaks or cracks in the boots.

## DISASSEMBLY (Non-Turbo)

Disassemble in the order shown below.

### Note

- a) Clamp the shaft in a vice. Use wood in the vice to avoid damage.
- b) Do not allow dust or foreign matter to enter the joint during disassembly or assembly.
- c) Do not disassemble the ball joint at the wheel side. Do not wipe off the grease if there is no problem.
- d) Do not remove the clip which is used to secure the outer ring to the ball joint at the differential side if there is no problem. If the clip is removed, replace it with a new one.

63U09X-017

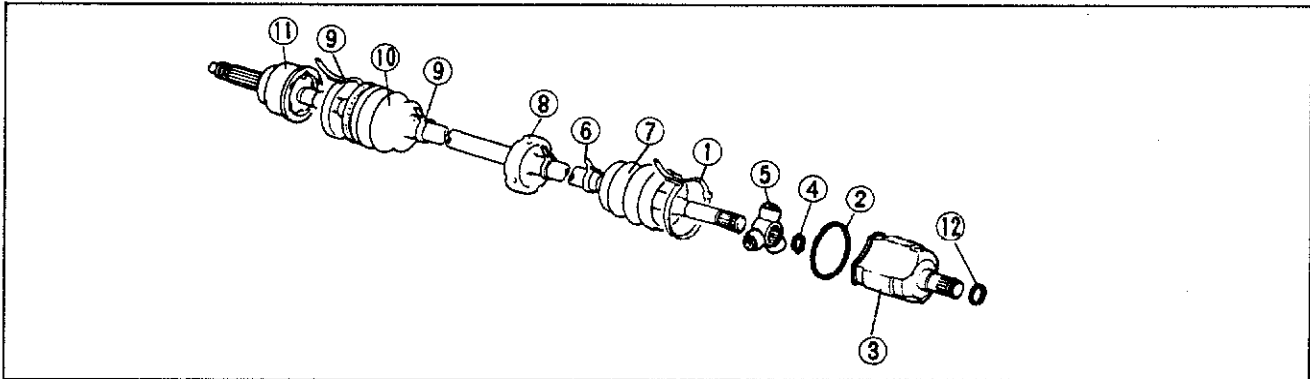

63U09X-047

- |                  |                                     |   |
|------------------|-------------------------------------|---|
| 1. Boot band     | 6. Boot band                        | 10. Boot  |
| 2. Clip          | 7. Boot                             | 11. Shaft and ball joint assembly   |
| 3. Outer ring    | 8. Dynamic damper (right side only) | 12. Clip (for locking the ball joint at the differential side outer ring) |
| 4. Snap ring     | 9. Boot band                        |   |
| 5. Tri-pod joint |                                     |   |

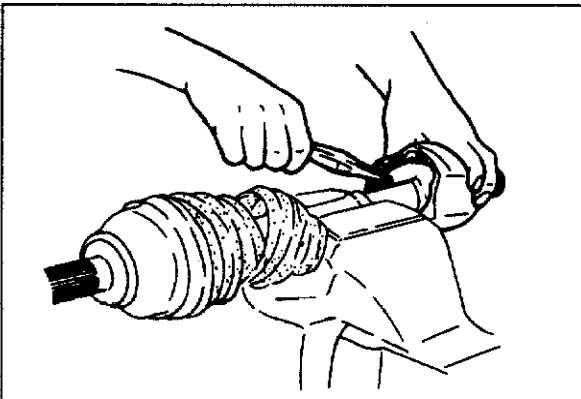

63G09X-004

### Clip

Remove the boot and then remove the clip with pliers.

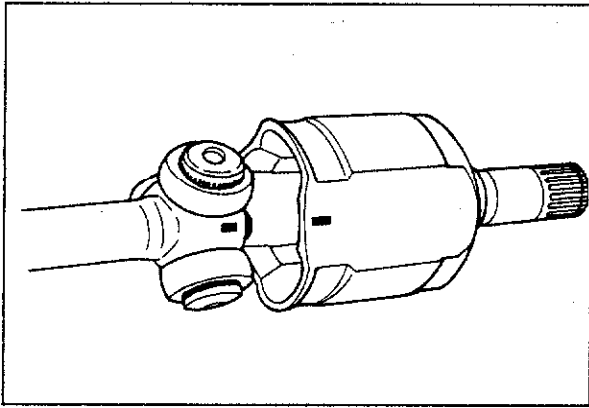

63U09X-049

### Outer Ring

Make matching marks on the tri-pod joint and outer ring.

### Note

Mark with paint, do not use a punch.

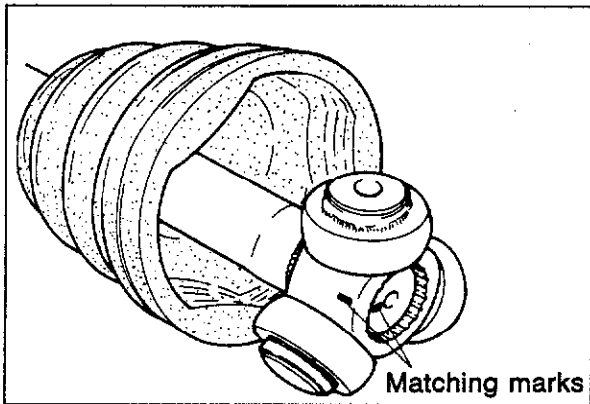

63U09X-050

### Tri-pod Joint

1. Remove the snap ring.
2. Make matching marks on the driveshaft end and tri-pod joint.

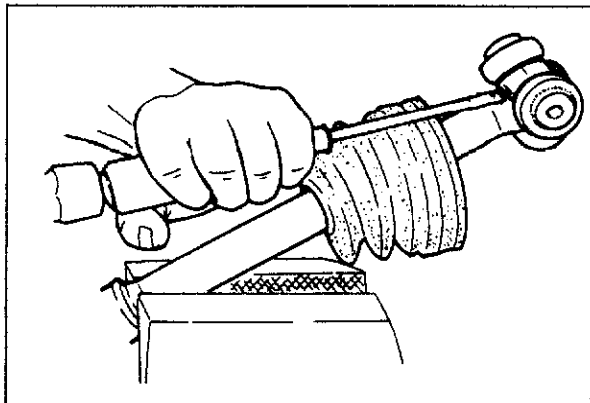

63U09X-051

3. Tap the boss with a hammer and rod to remove the tri-pod joint.

### Caution

Do not tap on the rollers.

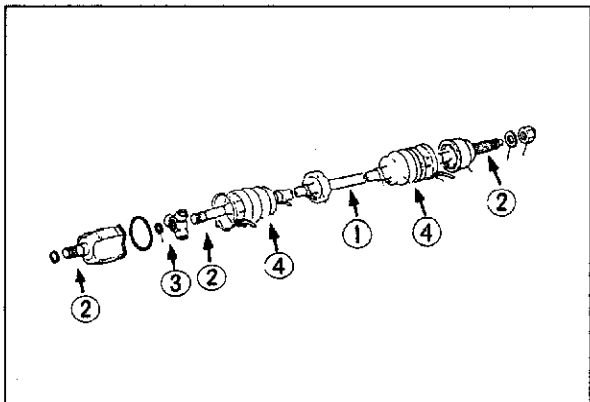

83U09X-018

### INSPECTION (Non-Turbo)

Check the following parts:

1. Twisted or cracked driveshaft.
2. Worn splines.
3. Excessively loose joint.
4. Cracked or damaged boots.

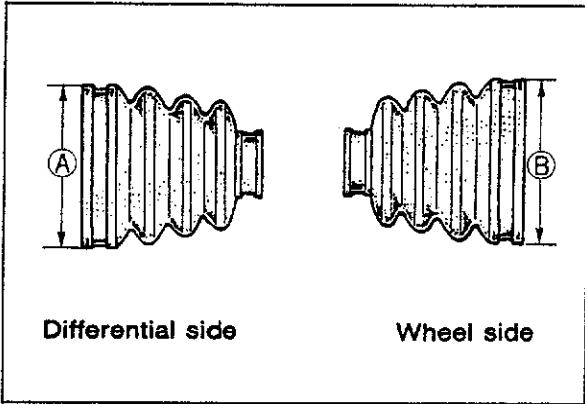

83U09X-026

## ASSEMBLY (Non-Turbo)

Assemble in the reverse order of disassembly and note the following:

### Boot

The shape of the ball joint boots at the wheel side and the differential side differ, so be careful not to install incorrectly.

- Ⓐ : 83.6 mm (2.39 in)
- Ⓑ : 90.4 mm (3.56 in)

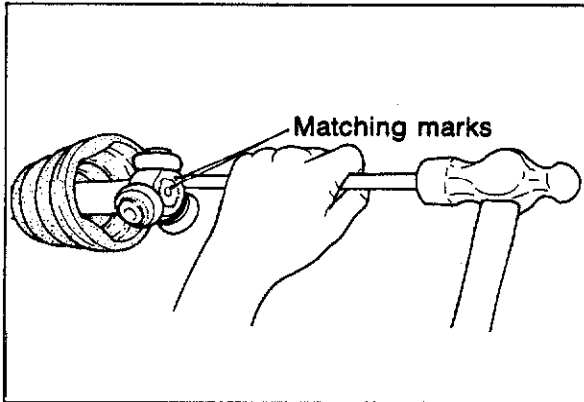

83U09X-027

### Tri-pod Joint

1. Before inserting the boot onto the shaft put tape on the shaft splines.
2. Align the matching marks and install the tri-pod joint with a rod and a hammer.

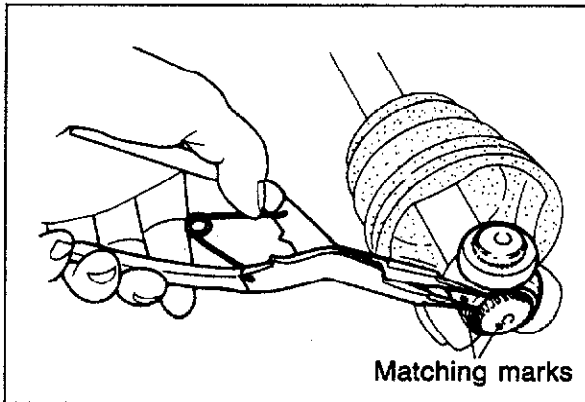

63U09X-055

3. Install the snap ring with snap ring pliers.

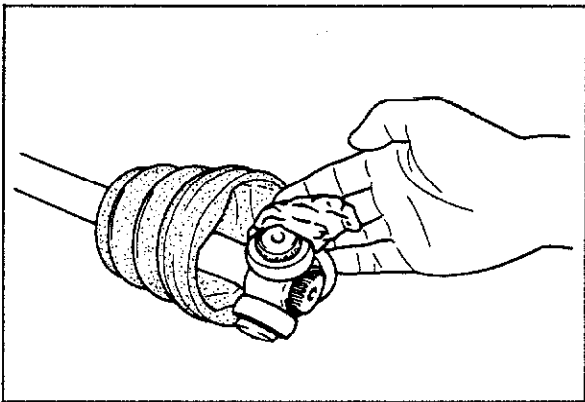

63U09X-056

4. Apply the specified grease (lithum) to the joint. Do not use any other type of grease.

### Note

The color of this grease is yellow, and it is supplied in the boot kit and joint kit.



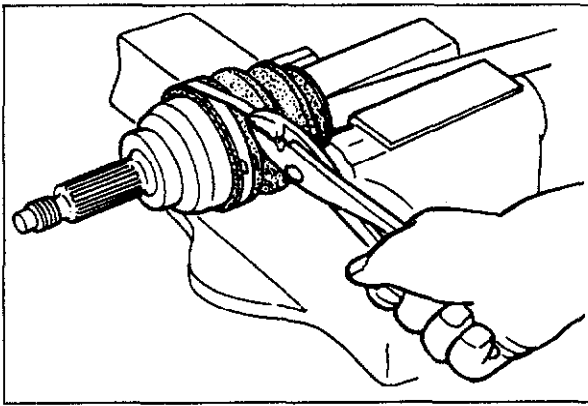

63U09X-057

### Boot Band

1. Fold the band back by pulling on the end of the band with pliers.
2. Lock the end of band by bending the locking clip.

### Note

- a) Always use a new band.
- b) The band should be folded in the direction opposite to the forward revolving direction of the driveshaft.

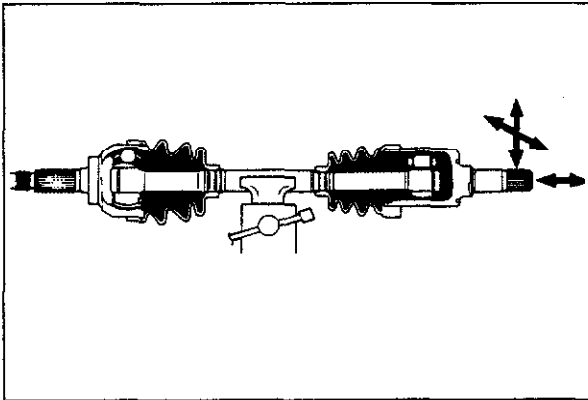

63U09X-058

- After assembling the driveshaft, check the following:
1. Make sure the joint parts move smoothly in the directions indicated by the arrows.
  2. Check the boots for grease leaks or damage.

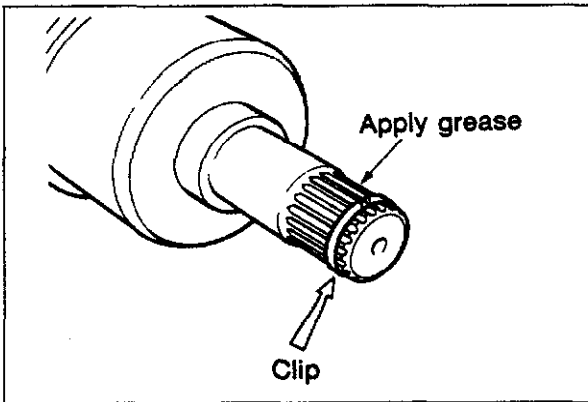

83U09X-020

### INSTALLATION

Install in the reverse order of removal and be careful of the following points:

### Note

**MTX and ATX are the same procedure.**

### Dynamic Damper

Make sure the dynamic damper position is as shown in the figure.

### Note

**When measuring the distance the ball joint is fully pushed toward the driveshaft.**

### Clip

Before inserting the driveshaft into the transaxle, make sure the oil seals are free of any scratches. If there are any problems, replace the oil seal. (Refer to Section 7A)

### Note

**The clip should be replaced with a new one.**

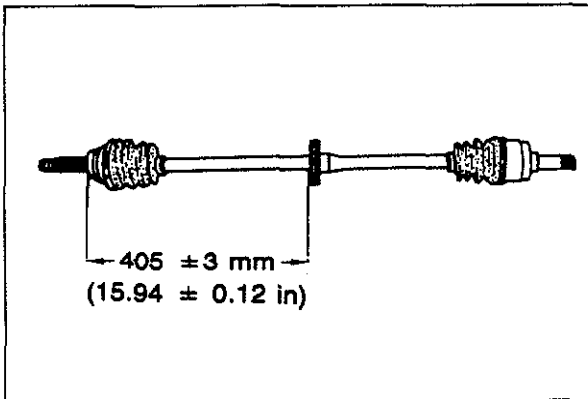

63U09X-060

# 9 DRIVESHAFT

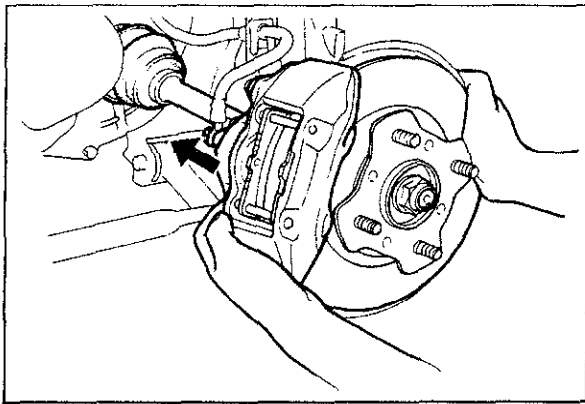

63U09X-061

## Driveshaft

When the driveshaft and the joint shaft are installed to the transaxle, be very careful not to damage the oil seal.

### Note

After installation, pull the front hub outward to check that the driveshaft does not come out.

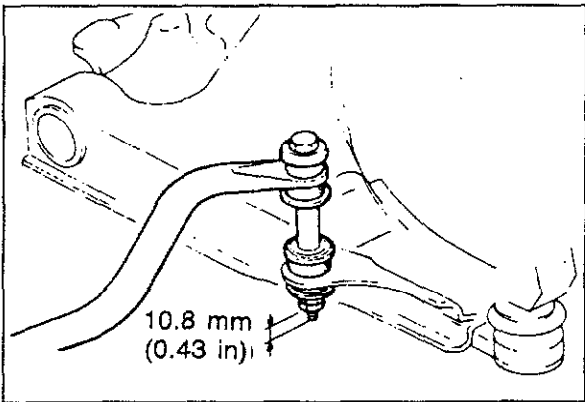

63U09X-062

## Stabilizer

The nut should be locked with **10.8 mm (0.43 in)** of the threaded part of the stabilizer bar control link exposed.

### Tightening torque:

**12—18 N·m**

**(1.2—1.8 m·kg, 8.7—13.0 ft·lb)**

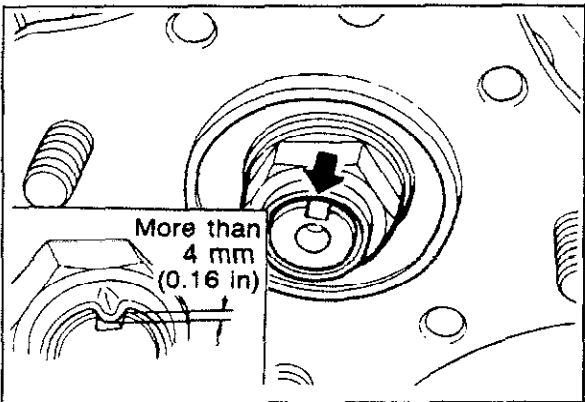

63U09X-063

## Driveshaft Locknut:

Use a new driveshaft locknut, tighten and, stake the locknut, ensuring that it seats into the groove in the driveshaft.

### Note

- a) Do not stake the nut with a pointed tool.
- b) Make sure the wheel hub can be turned smoothly by hand.

### Driveshaft locknut:

**157—235 N·m (16—24 m·kg, 16—174 ft·lb)**

### Knuckle to lower arm ball joint:

**43—54 N·m (4.4—5.5 m·kg, 32.5—39.8 ft·lb)**

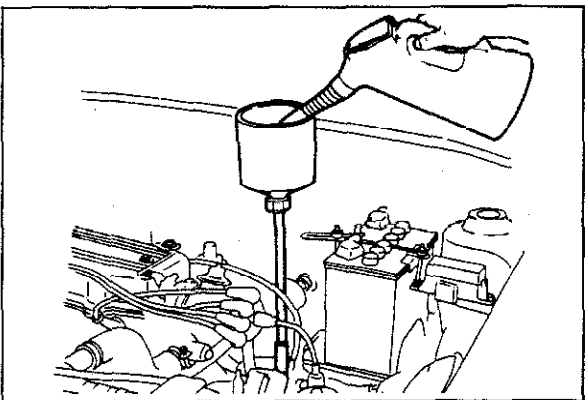

63U09X-064

## Transaxle

Be sure to use the specified grade and quantity of transaxle oil.

(Refer to Section 7)

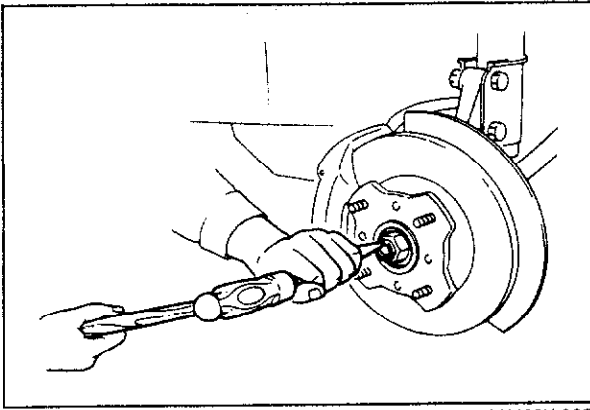

63U09X-065

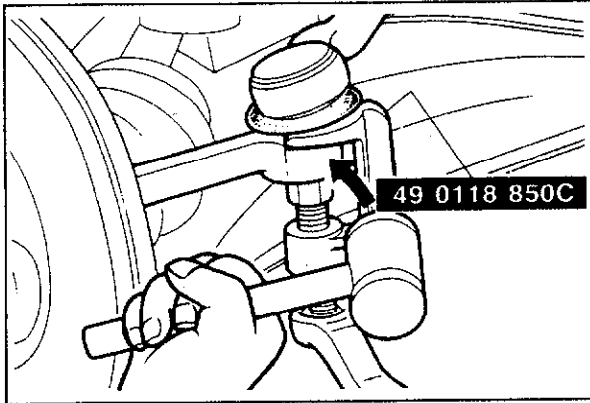

83U09X-028

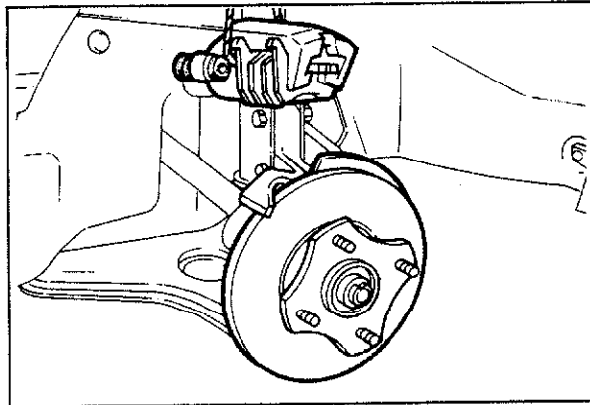

63U09X-067

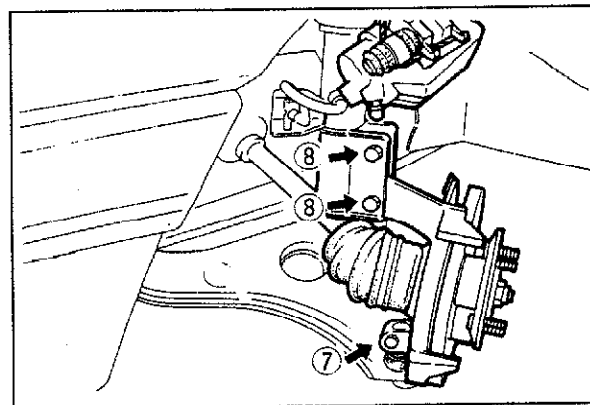

63U09X-068

## FRONT AXLE

### REMOVAL

1. Raise the front of the vehicle and support it with safety stands.
2. Remove the wheel.
3. Raise the nut tab and remove the driveshaft locknut.

#### Note

**When loosening the nut, lock the hub by applying the brakes.**

4. Remove the split pin from the tie-rod end locknut.
5. Separate the tie-rod end from the knuckle with the SST.

#### Note

**If it is difficult to separate, tap the knuckle and ball joint with a hammer.**

6. Remove the caliper assembly from the knuckle, and hang it from the shock absorber.

7. Remove the clamp bolt and nut, and push the lower arm downward to separate the knuckle and the ball joint.
8. Remove the bolts and nuts which couple the knuckle and the shock absorber.

# 9 FRONT AXLE

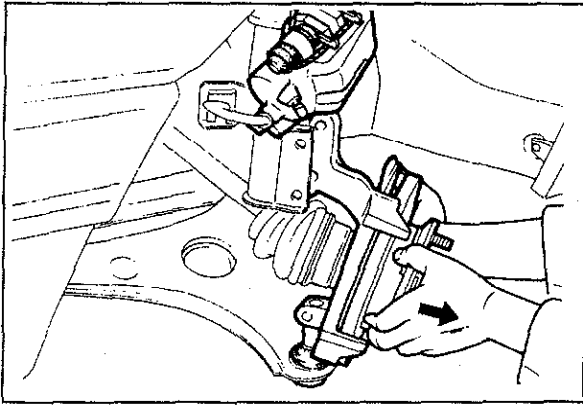

83U09X-029

9. Separate the front hub and the knuckle from the driveshaft.  
If the driveshaft can not be separated from the front hub, use **SST**.

**Note**  
Be careful not to damage the oil seal.

## DISASSEMBLY

Disassemble in the order shown in the figure.

### Note

- a) Do not remove the dust cover, unless necessary for repairs.
- b) Do not confuse the inner bearing with the outer bearing.

63U09X-070

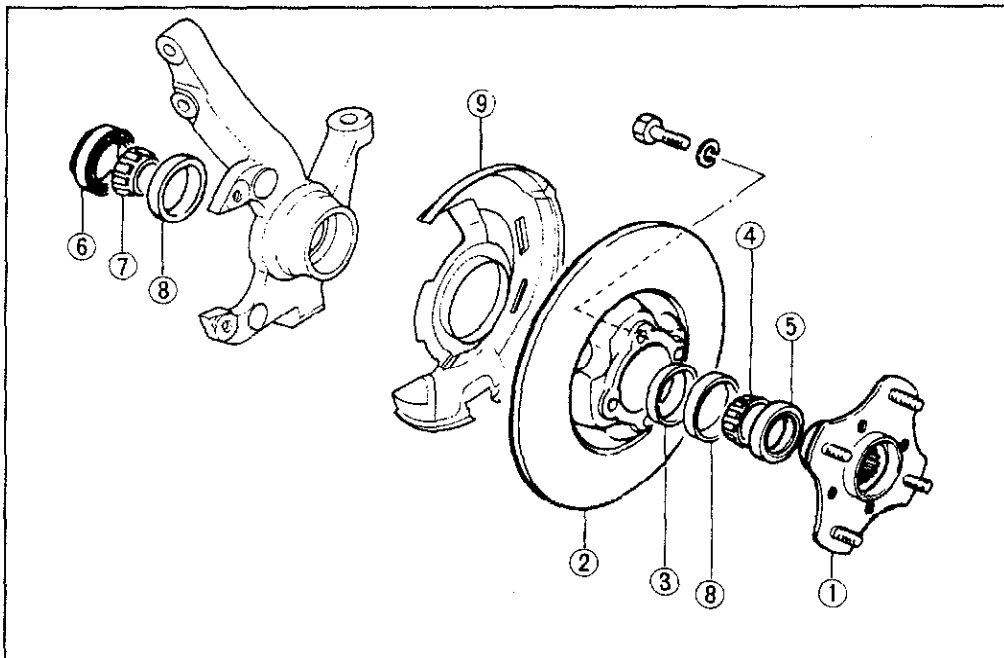

1. Wheel hub
2. Disc plate
3. Spacer
4. Outer bearing inner race
5. Outer oil seal
6. Inner oil seal
7. Inner bearing inner race
8. Bearing outer race
9. Dust cover

63U09X-071

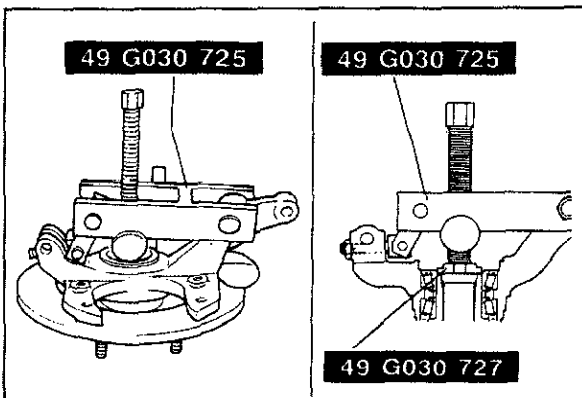

83U09X-030

## Wheel Hub

Remove the wheel hub with **SST**.

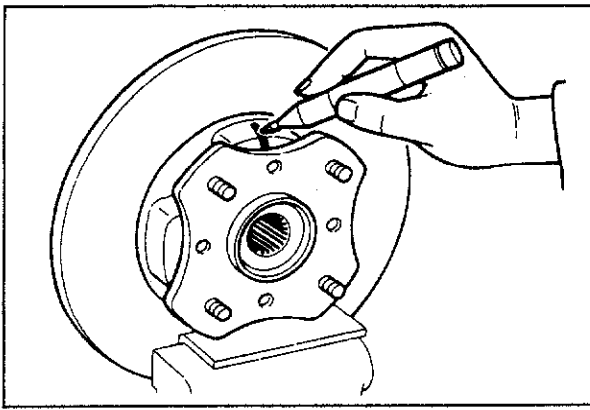

63U09X-073

### Disc Plate

After making matching marks on the disc plate and the wheel hub, disassemble the plate and the hub.

#### Note

Use copper plates when clamping the disc plate in the vise.

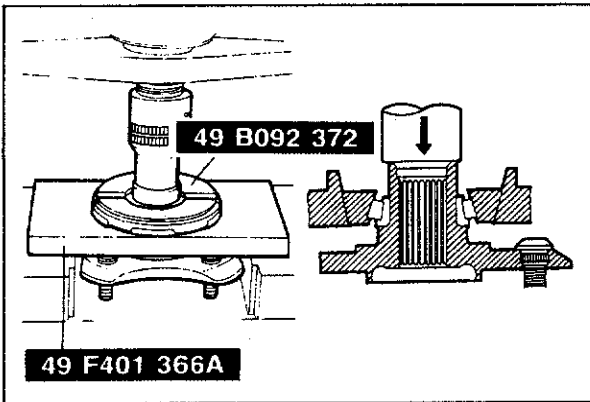

83U09X-031

### Wheel Bearing

1. Remove the outer bearing inner race with **SST**.

#### Note

Hold the hub to prevent it from falling.

2. Remove the outer oil seal from the front hub.

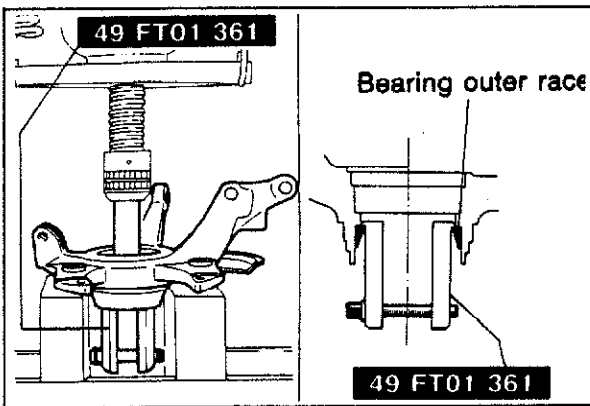

83U09X-032

3. Remove the bearing outer race with **SST** and a press.

#### Note

a) Do not remove the bearing unless it is necessary.  
b) Remove the race gradually and carefully.

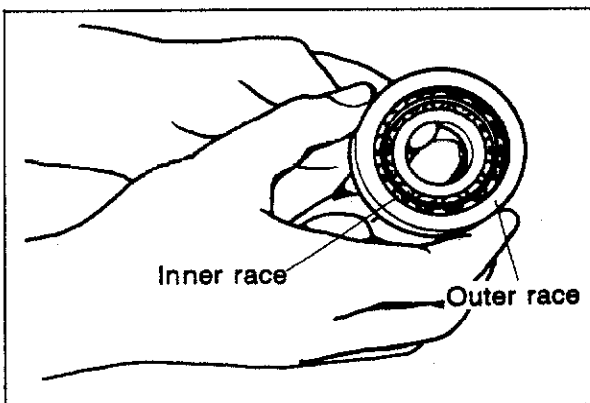

63U09X-076

### INSPECTION

Wash the disassembled parts before inspecting. Replace any damaged parts. Minor rust should be removed with fine sandpaper.

Inspect for:

1. Abnormal wear damage or seizure of bearing.

#### Note

Replace the bearing as a set (inner and outer races).

# 9 FRONT AXLE

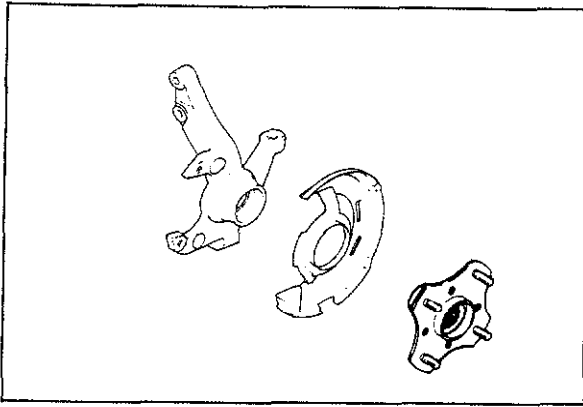

63U09X-077

2. Cracks or damage of the knuckle. Scoring or rust of the bearing bore.
3. Damaged dust cover or poor fit with knuckle.
4. Cracks or damage of the hub. Scoring or rust of the bearing bore. Wear at the oil seal's contact surface.

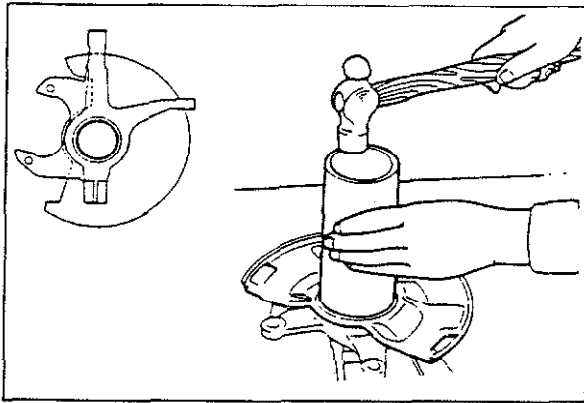

83U09X-033

## ASSEMBLY

Assemble in the reverse order of disassembly and note the following:

### Dust Cover

Press-fit the dust cover with a pipe and a hammer.

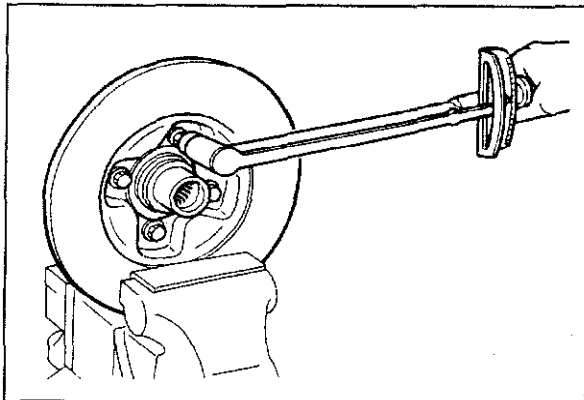

63U09X-079

### Disc Plate

Align the disc plate and wheel hub matching marks, assemble the plate and the hub, and tighten the mounting bolts.

### Tightening torque:

44—54 N·m (4.5—5.5 m·kg, 33—40 ft·lb)

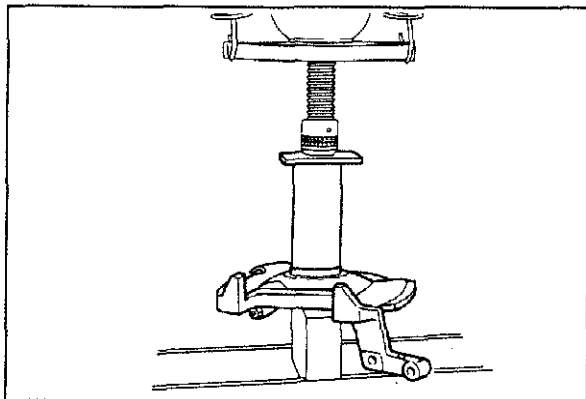

63U09X-080

### Bearing Outer Race

Place a suitable pipe [outer diameter 65—67 mm (2.56—2.64 in)] against the wheel bearing outer race and press the bearing into the knuckle.

### Note

Press in until the edge of the race contacts the knuckle.

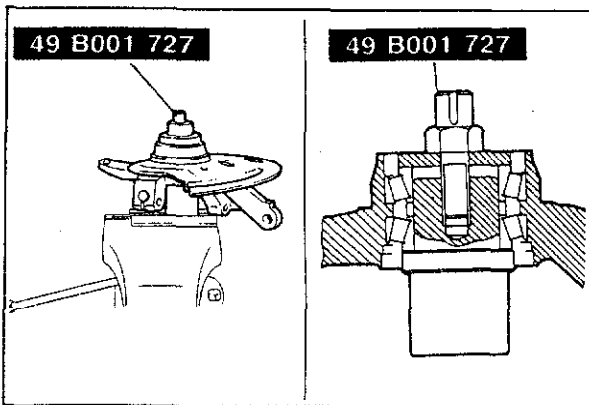

83U09X-034

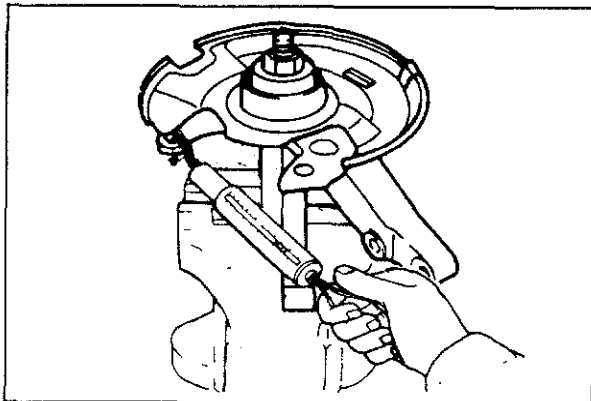

83U09X-035

**Bearing Preload**

Adjust the bearing preload according to the following procedures.

1. Insert the bearing and spacer into the knuckle and attach **SST**.

**Note**

Use the removed spacer.

2. Measure the bearing preload after the **SST** is tightened.

**Tightening torque:**

196 N·m (20 m·kg, 145 ft·lb)

**Bearing preload (Rotation starting torque)**

0.25—1.18 N·m

(2.5—12.0 cm·kg, 2.17—10.42 in·lb)

As measured at caliper mounting hole of knuckle

13 inch wheel

2.4—11.4 N (0.24—1.16 kg, 0.53—2.55 lb)

14 inch wheel

2.2—10.6 N (0.22—1.07 kg, 0.48—2.35 lb)

**Note**

When tightening, torque in steps of 49 N·m (5.0 m·kg, 36.2 ft·lb) each time.

3. If the preload is not within specification, adjust it.
4. Use the table and select the proper spacer to adjust the preload.

**Note**

Increase the spacer thickness when the preload is too high and decrease it when the preload is too low. When a spacer is changed by 1 rank, the preload changes 0.2 to 0.4 N·m (2.0 to 4.0 cm·kg, 1.7 to 3.5 in·lb). The marking is stamped on the outer periphery of the spacer.

Stamped mark	Thickness
1	6.285 mm (0.2474 in)
2	6.325 mm (0.2490 in)
3	6.365 mm (0.2506 in)
4	6.405 mm (0.2522 in)
5	6.445 mm (0.2538 in)
6	6.485 mm (0.2554 in)
7	6.525 mm (0.2570 in)
8	6.565 mm (0.2586 in)
9	6.605 mm (0.2602 in)
10	6.645 mm (0.2618 in)
11	6.685 mm (0.2634 in)
12	6.725 mm (0.2650 in)
13	6.765 mm (0.2666 in)
14	6.805 mm (0.2682 in)
15	6.845 mm (0.2698 in)
16	6.885 mm (0.2714 in)
17	6.925 mm (0.2730 in)
18	6.965 mm (0.2746 in)
19	7.005 mm (0.2762 in)
20	7.045 mm (0.2778 in)
21	7.085 mm (0.2794 in)

83U09X-083

# 9 FRONT AXLE

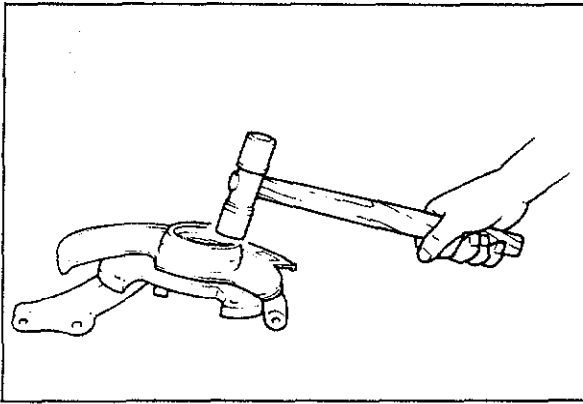

63U09X-084

## Oil Seal

Install the outer oil seal with a plastic hammer.

### Note

- a) Use a new oil seal and apply grease to the lip of the seal.
- b) Make sure the oil seal is installed flush with the knuckle.

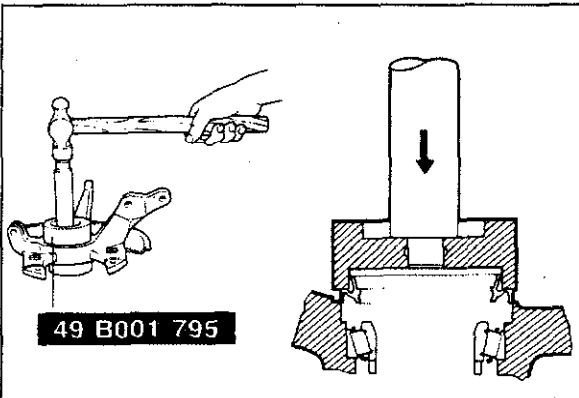

49 B001 795

83U09X-036

Install the inner oil seal with **SST** and a hammer.

### Note

- a) Use a new oil seal and apply grease to the lip of the seal.
- b) Make sure the oil seal is installed flush with the knuckle.

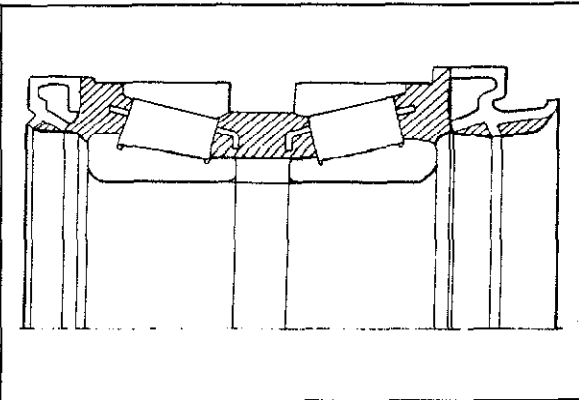

63U09X-086

## Grease

Completely fill the shaded area in the figure with lithium grease (**NLGI No. 2** or equivalent).

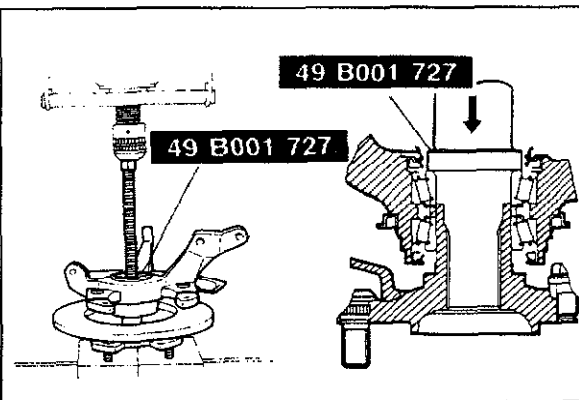

49 B001 727

49 B001 727

83U09X-037

## Wheel Hub

When press-fitting the wheel hub into the knuckle (with the bearing and oil seal), use **SST** and press-fit with a press.

**Press to 24,500 N (2,500 kg, 5,500 lb)**



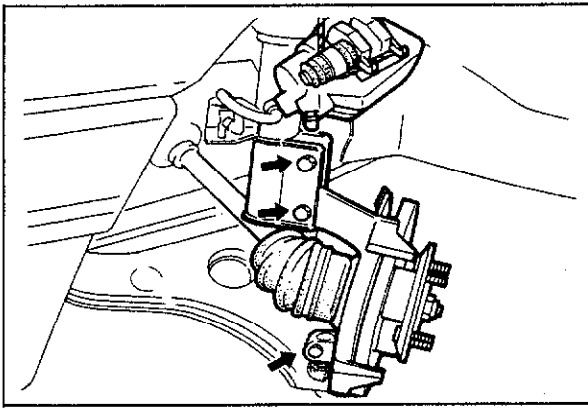

63U09X-088

**INSTALLATION**

Install in the reverse order of removal and note the following:

1. Mount the front hub and knuckle to the driveshaft, and then mount the knuckle to the lower arm ball joint and to the shock absorber. Tighten the mounting bolts and nuts.

**Tightening torque:**

**Knuckle to shock absorber**

93—117 N·m (9.5—11.9 m·kg, 69—86 ft·lb)

**Knuckle to lower arm ball joint**

43—54 N·m (4.4—5.5 m·kg, 32—40 ft·lb)

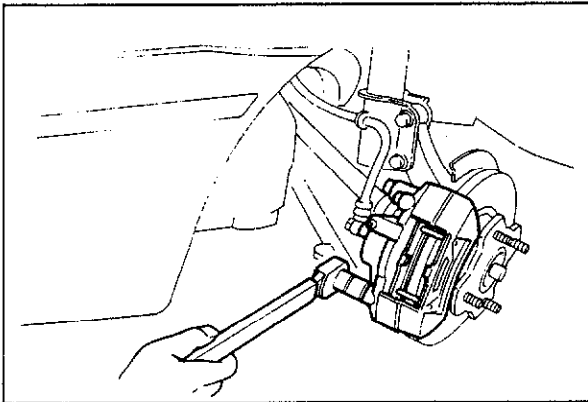

63U09X-089

2. Install the disc brake caliper assembly.

**Tightening torque:**

39—49 N·m (4.0—5.0 m·kg, 29—36 ft·lb)

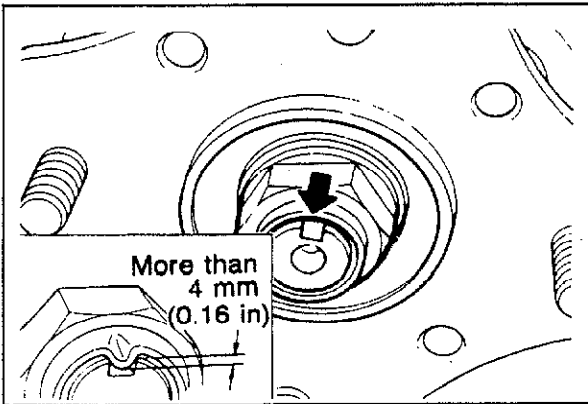

63U09X-090

3. Use a new driveshaft locknut, tighten it to the specified torque and stake it into the groove securely.

**Tightening torque:**

157—235 N·m

(16.0—24.0 m·kg, 116—174 ft·lb)

**Note**

- a) Do not use a pointed tool for staking.
- b) Make sure the wheel hub turns freely by hand.

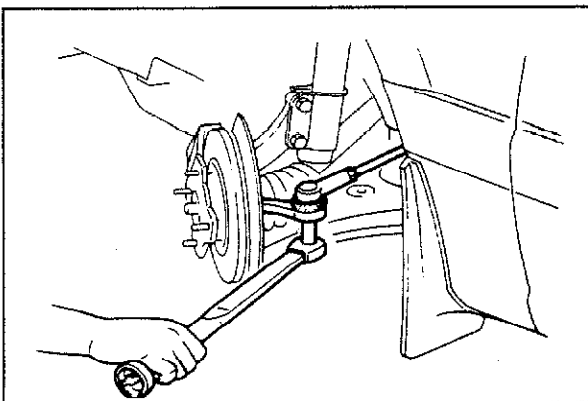

63U09X-091

4. Install the tie-rod end to the knuckle and tighten the nut.

**Tightening torque:**

29—44 N·m (3.0—4.5 m·kg, 22—33 ft·lb)

**Note**

Use a new split pin.

5. Install the wheel and tighten the wheel lug nuts.

**Tightening torque:**

88—118 N·m (9.0—12.0 m·kg, 65—87 ft·lb)

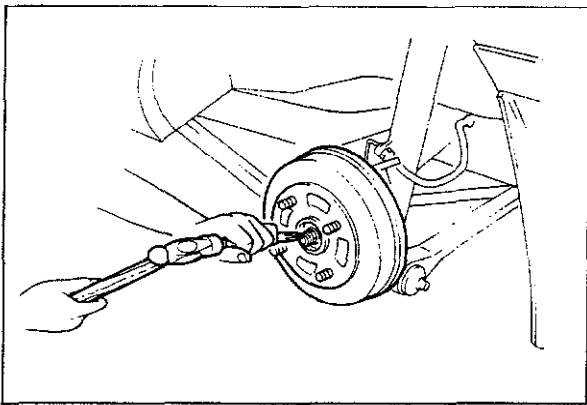

63U09X-092

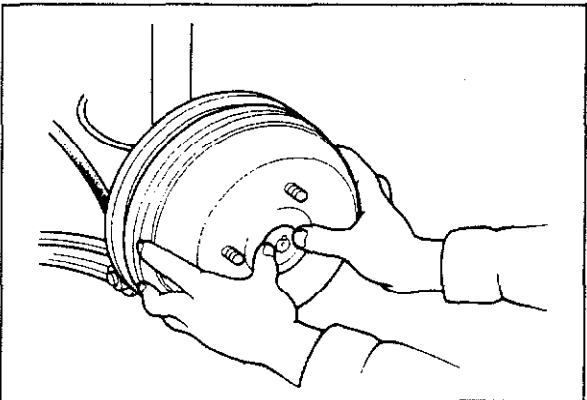

63U09X-093

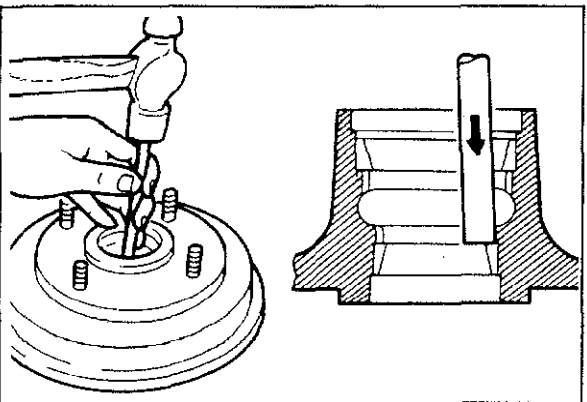

63U09X-094

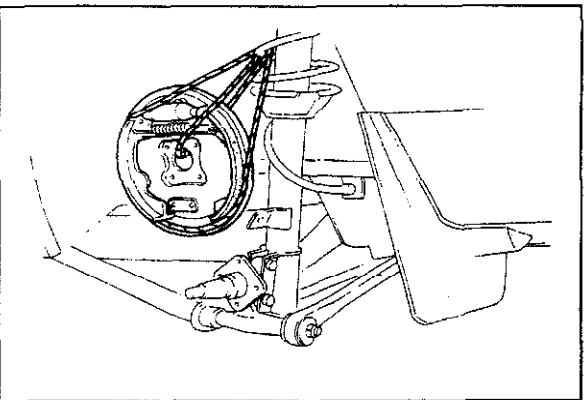

63U09X-095

## REAR AXLE

### REMOVAL

#### Drum Brake

1. Raise the rear of the vehicle and support it with safety stands.
2. Remove the following parts:
  - (1) Wheel and tire
  - (2) Hubcap
  - (3) Locknut

#### Caution

- a) Raise the nut tab to loosen the locknut.
- b) To remove the right side rear locknut, turn it clockwise.

- (4) Brake drum

#### Note

- If it is difficult to remove the brake drum increase the shoe clearance. (Refer to Section 11)

- (5) Oil seal
- (6) Bearing inner race

- (7) Bearing outer race

#### Note

- a) Check the bearing races and disassemble only if necessary.
- b) Set a brass rod on the race through the grooves (four locations) in the hub and remove the race with a hammer.

#### Rear hub spindle

1. Remove the brake line clip.
2. Remove the back plate and brake assembly and hang it from the shock absorber.

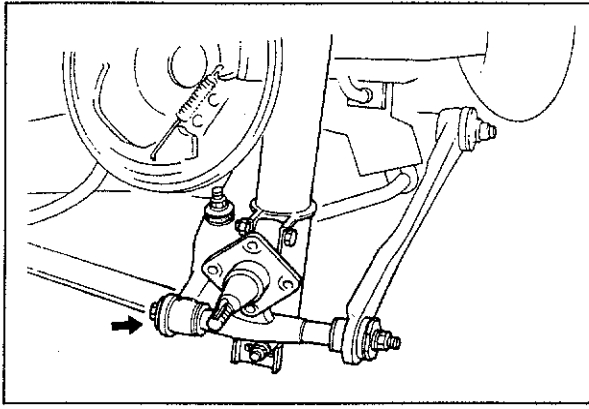

63U09X-096

3. Remove the lateral link through bolt.

**Note**

This bolt should be removed after loosening the hub spindle to shock absorber through bolts and it can be easily removed by lifting up on the hub spindle.

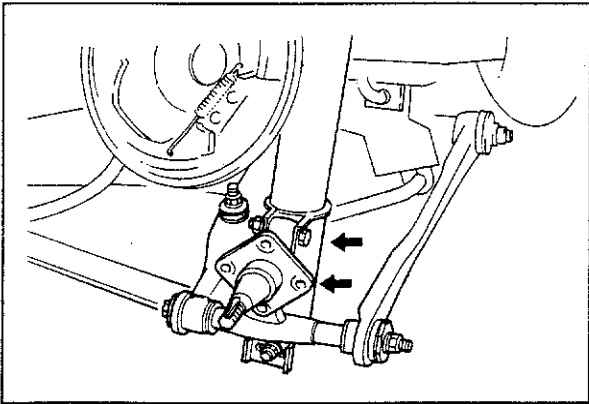

63U09X-097

4. Remove the hub spindle to shock absorber through bolts.
5. Remove the hub spindle.

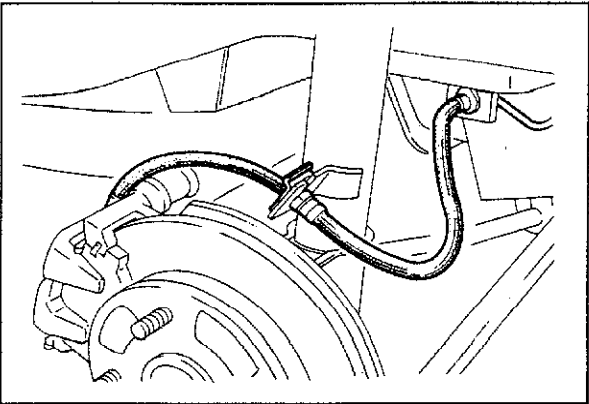

63U09X-098

**Disc Brake**

1. Jack up the rear of the vehicle and support it with safety stands.
2. Remove the following parts:
  - (1) Wheel and tire
  - (2) Hub cap
  - (3) Brake line from the shock absorber

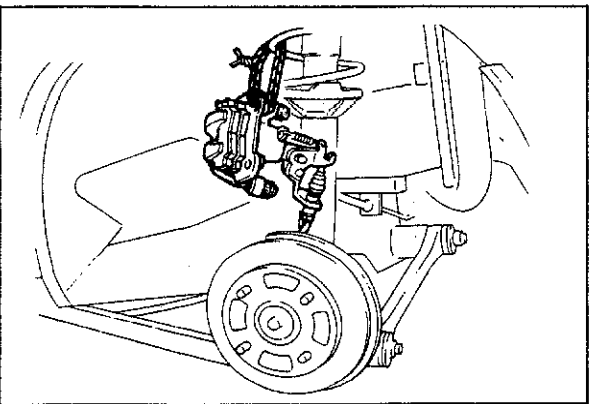

63U09X-099

- (4) Remove the caliper assembly from the knuckle, and hang it from the shock absorber.

# 9 REAR AXLE

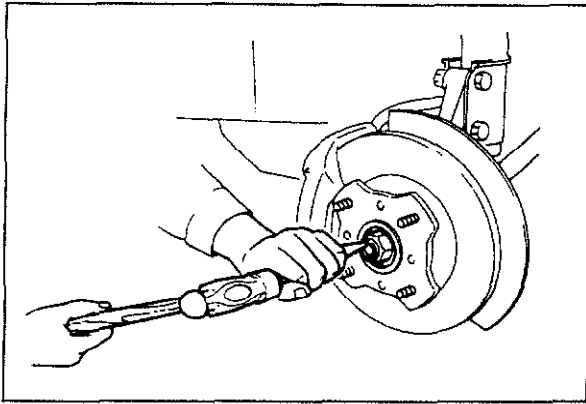

83U09X-021

(5) Locknut

### Caution

- a) Raise the nut tab to loosen the locknut.
- b) To remove the right side rear locknut, turn it clockwise.

(6) Dust cover

(7) Lateral link through bolt

(8) Hub spindle to shock absorber through bolts

(9) Hub spindle

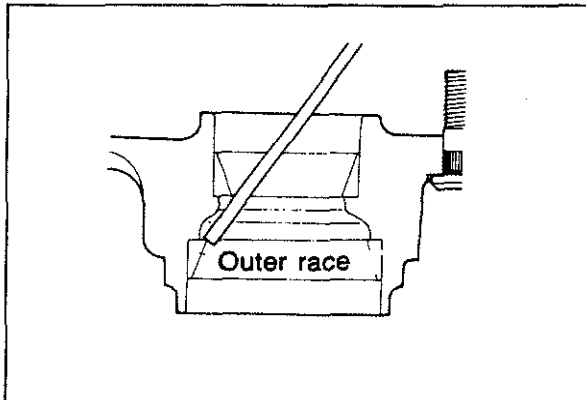

63U09X-101

(10) Rear axle hub

### Note

- a) Do not disassemble the bearing if it is not necessary.
- b) Set a brass rod on the race through the grooves in the hub and remove the race with a hammer.

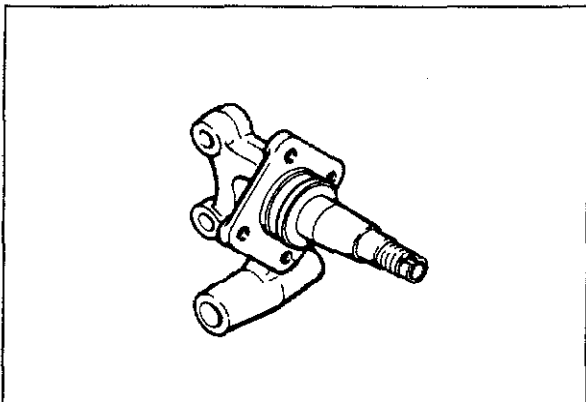

63U09X-102

## INSPECTION

### Rear Hub Spindle

Check the following and, if there is any problem replace the rear hub spindle.

1. Cracks or damage.
2. Wear or rust on the oil seal contact surface.

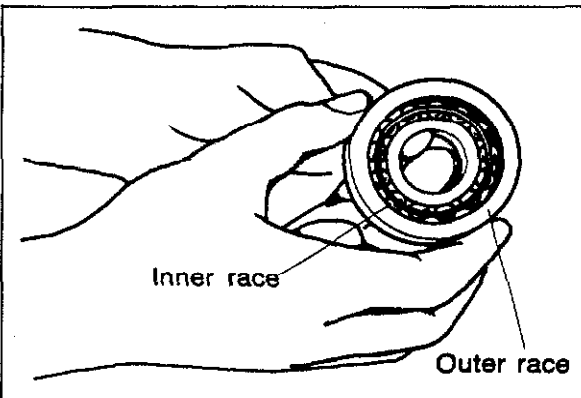

63U09X-103

### Bearing

Wash all parts, check the following and replace if necessary.

1. Abnormal wear, damage or seizure of bearing.

### Note

Replace the bearing as a set (inner and outer races).

2. Damaged hub grease cap

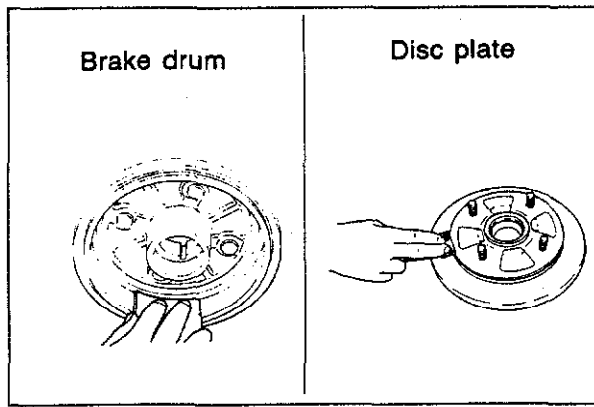

63U09X-104

## Disc Plate or Brake Drum

Wear or damage to brake drum or disc plate.

### Note

Remove minor rust with sandpaper.

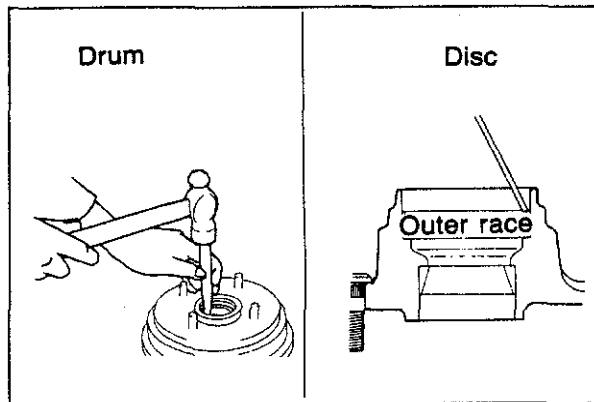

63U09X-105

## INSTALLATION

Install in the reverse order or removal and note the following:

1. To install bearing outer race, use a hammer and a brass rod.

### Note

Tap in until the outer race is fully seated in the hub.

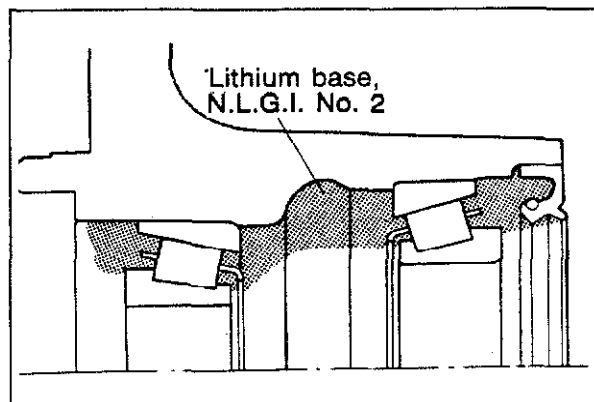

63U09X-106

2. Completely fill the area shaded in the figure with lithium grease (**NLGI No. 2** or equivalent).

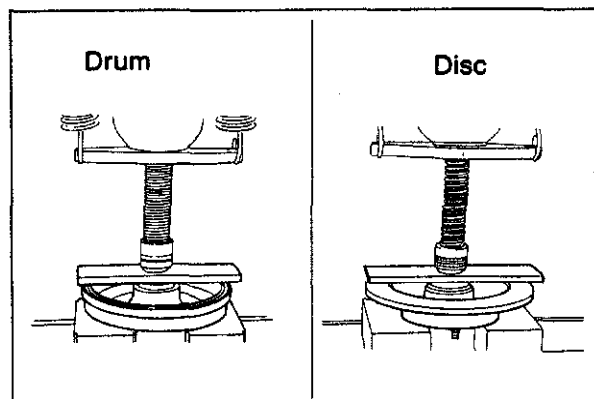

63U09X-107

3. Install the bearing inner race and oil seal.

### Note

a) Use a new oil seal, and coat the lip with grease after installation.

b) Do not hit the oil seal directly with a hammer; be sure to use a flat plate to press it in.

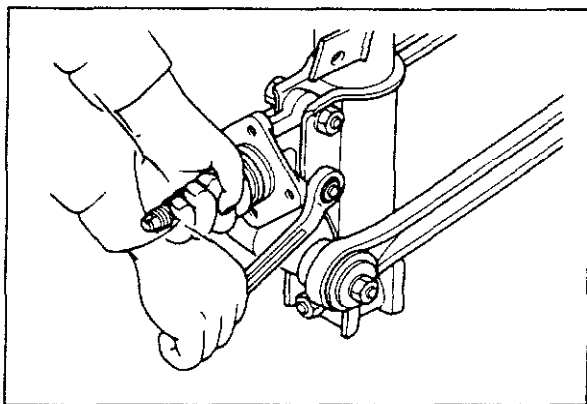

63U09X-108

4. The lateral link through bolt should be tightened (final tightening) after the installation work is completed and the jack is removed.

**Tightening torque:**

**Hub spindle to shock absorber**

93—117 N·m (9.5—11.9 m·kg, 69—86 ft·lb)

**Lateral link through bolt**

93—117 N·m (9.5—11.9 m·kg, 69—86 ft·lb)

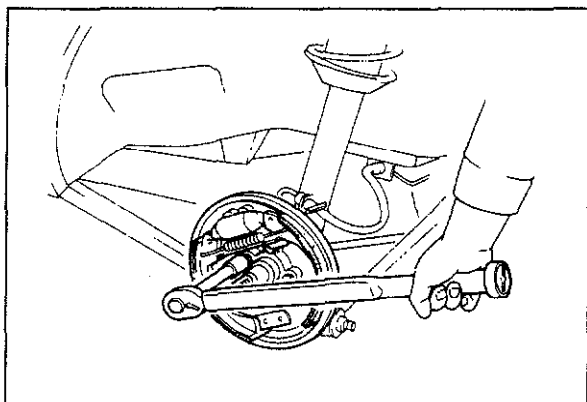

63U09X-109

**Brake**

**Drum brake**

1. Install the back plate and brake assembly to the hub spindle.

**Tightening torque:**

45—67 N·m (4.6—6.8 m·kg, 33—49 ft·lb)

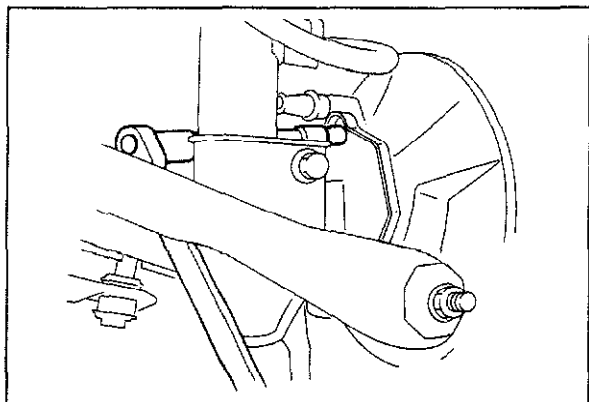

63U09X-110

**Disc brake**

1. Install the dust cover on the hub spindle.

**Tightening torque:**

45—67 N·m (4.6—6.8 m·kg, 33—49 ft·lb)

2. Install the caliper assembly.

**Tightening torque:**

49—69 N·m (5.0—7.0 m·kg, 36—51 ft·lb)

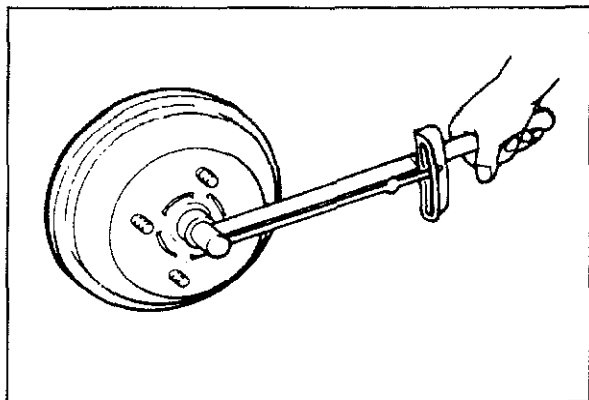

63U09X-111

**Bearing Preload**

Adjust the bearing preload according to the following procedures:

1. Tighten the locknut.

**Tightening torque:**

25—29 N·m (2.5—3.0 m·kg, 18.1—21.7 ft·lb)

**Note**

Use a new locknut.

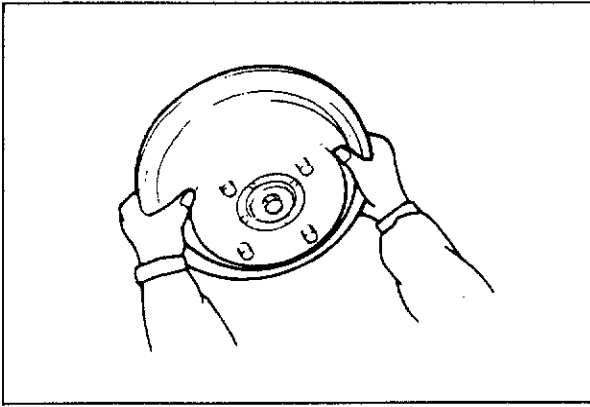

63U09X-112

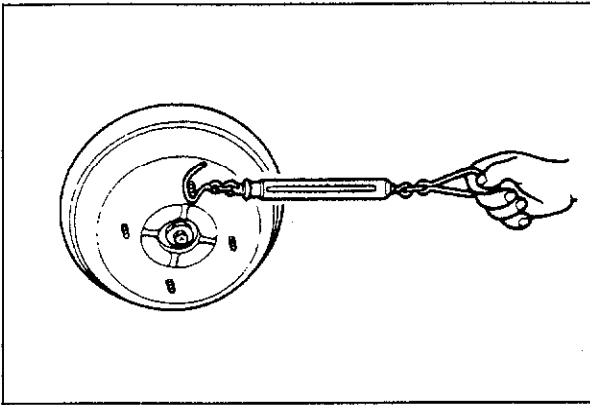

53G09X-009

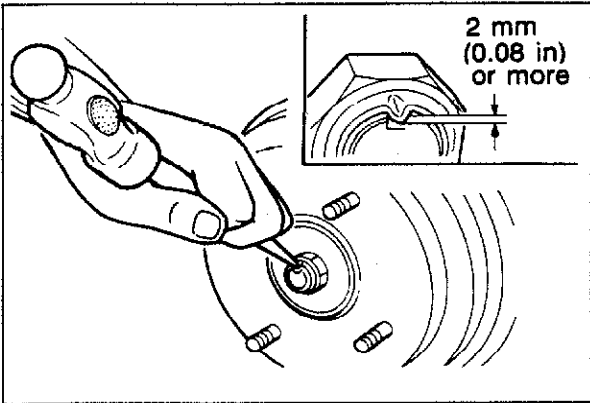

63U09X-114

2. Turn the wheel hub a few times to seat the bearing properly.

3. Loosen the locknut slightly until it can be turned by hand.

4. Hook a spring scale to measure the oil seal drag.

5. Pull the spring scale squarely. Take the oil seal drag value when the wheel hub starts to turn and record it.

6. Add the oil seal drag value in the previous step to the specified value of **2.6—8.5 N (0.26—0.87 kg, 0.6—1.9 lb)**. This is regarded as the standard bearing preload.

**Bearing preload (Rotation starting torque)**

**0.15—0.49 N·m**

**(1.5—5 cm·kg, 1.30—4.34 in·lb)**

7. Turn the locknut slowly until the standard bearing preload (determined in step 6) is obtained.

**Locknut**

Stake the locknut to the groove in the rear spindle.

**Note**

**Do not use a pointed tool for staking.**

Tighten the wheel lug nuts.

**Tightening torque:**

**88—118 N·m (9.0—12.0 m·kg, 65—87 ft·lb)**

## 4WD OUTLINE

### OUTLINE OF CONSTRUCTION

4-wheel-drive (4WD) is used the newly established parts for 4WD are as follows:

- The jointshaft of front driveshaft
- The rear differential
- The rear driveshaft

83U09X-022

### STRUCTURAL VIEW

#### Front Driveshaft

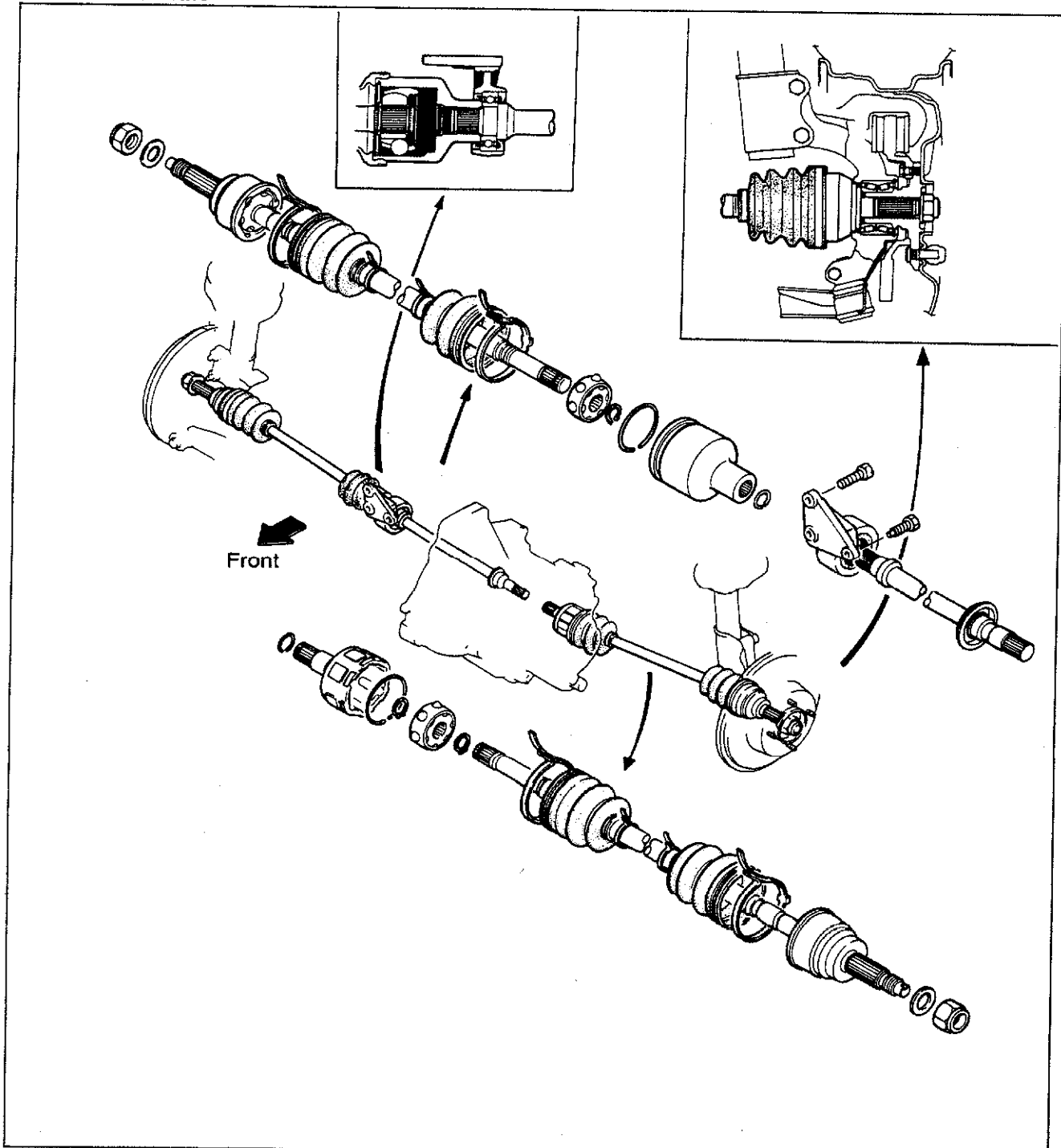

63G09X-302



Rear Differential

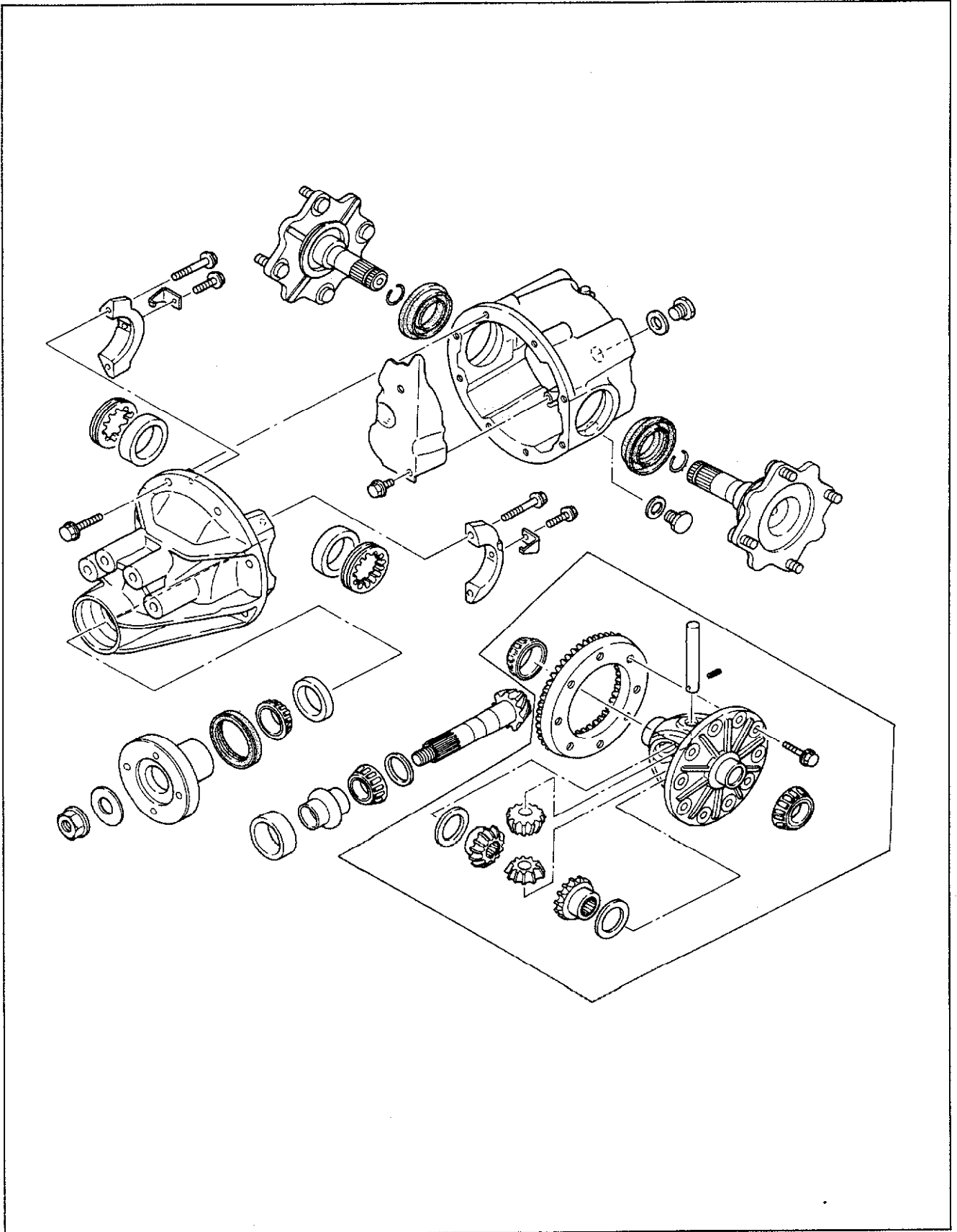

63G09X-303

# 9 OUTLINE

## Rear Driveshaft

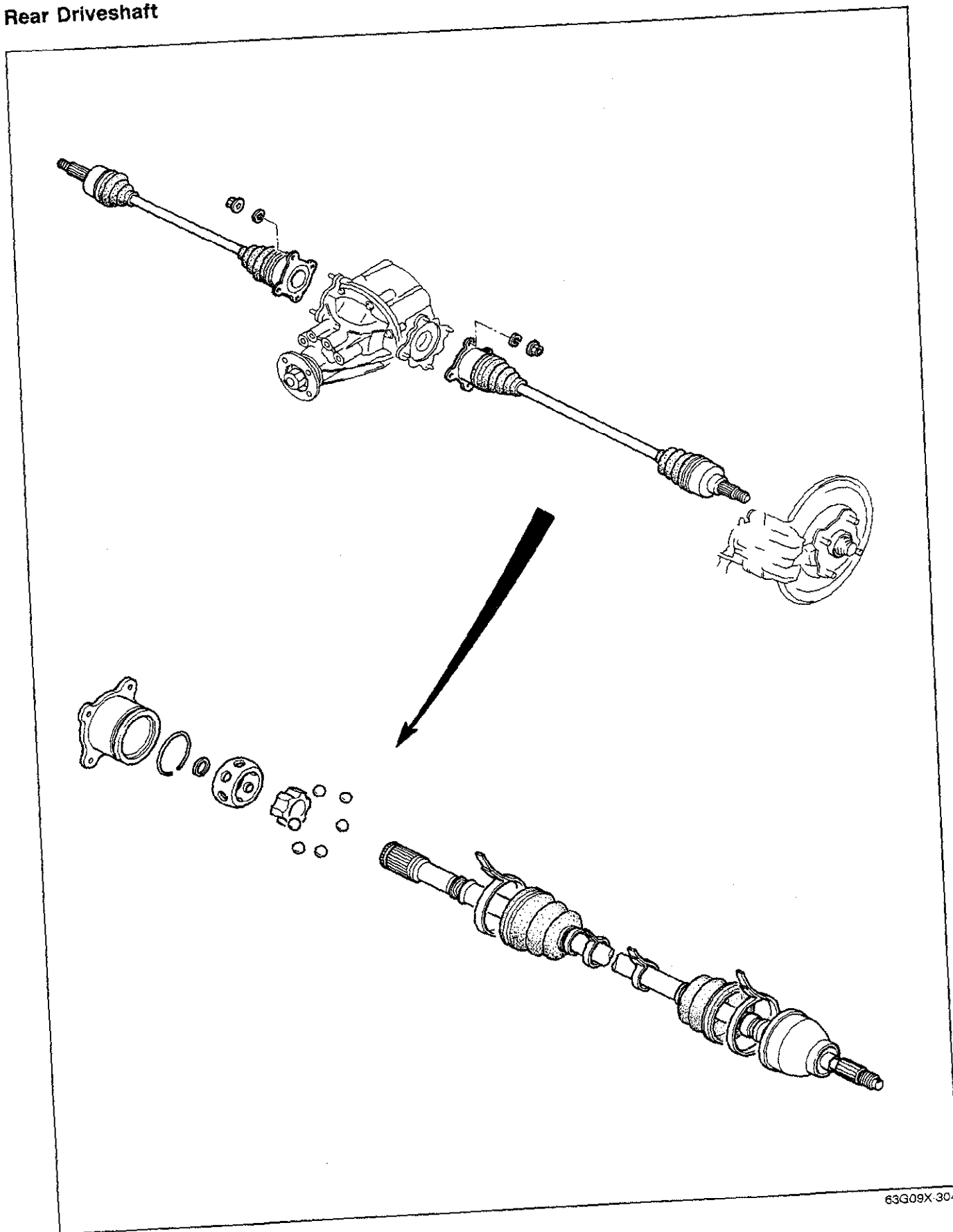

Rear Axle

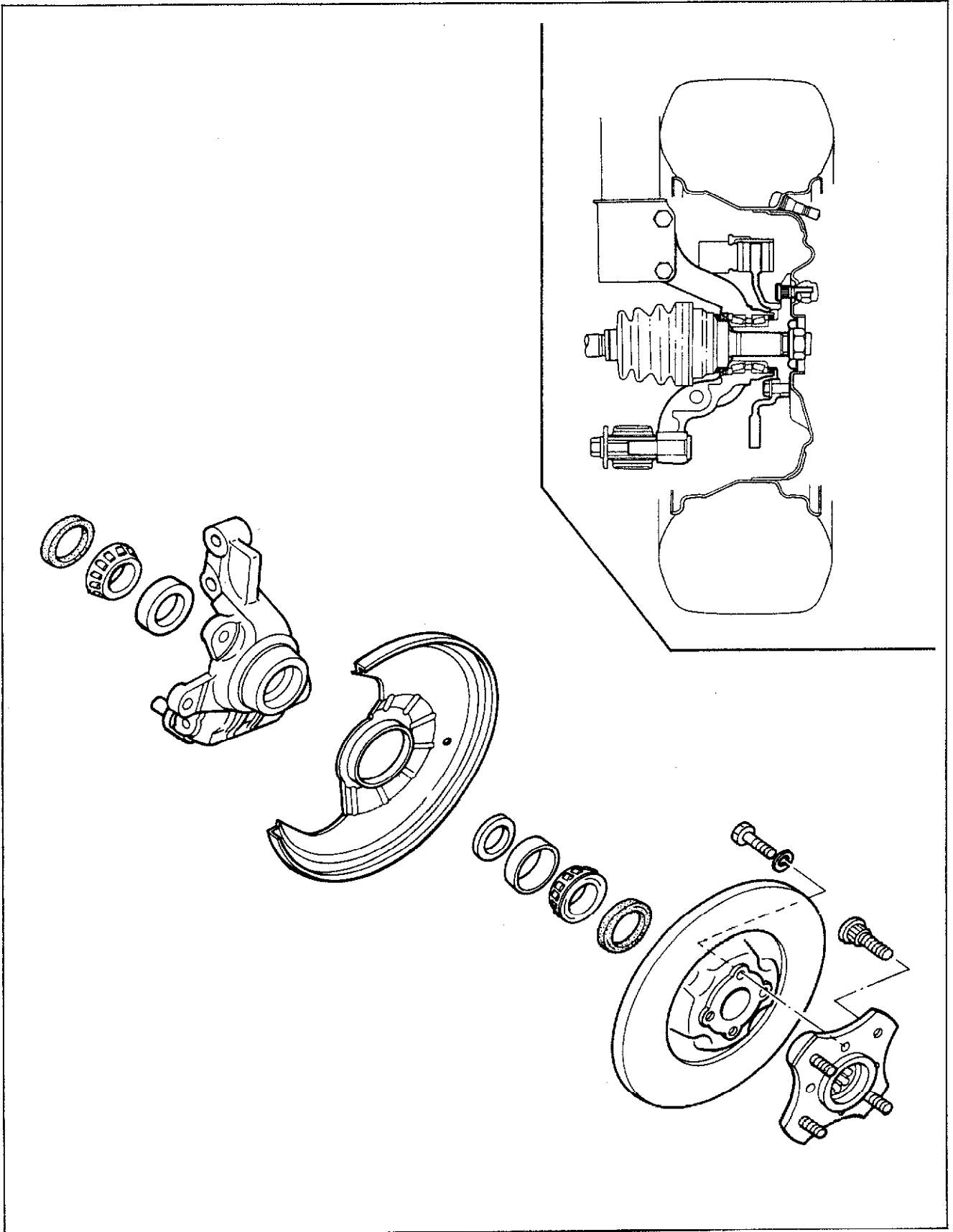

63G09X-305

# 9 TROUBLESHOOTING GUIDE

## SPECIFICATIONS

Front axle		
Bearing play — axial direction	mm (in)	0 (0)
Bearing preload	Pull scale reading N (kg, lb)	2.0—8.8 (0.2—0.9, 0.4—2.0)
Rear axle		
Bearing end play	mm (in)	0
Rear differential		
Reduction gear		Hypoid gear
Differential gear		Straight bevel gear
Reduction ratio		3.909
Number of teeth	Ring gear	43
	Drive pinion gear	11
Oil	Grade	API Service GL-5
	Viscosity	SAE 90 or 80W-90
	Amount: liter (US qt, Imp qt)	0.65 (0.69, 0.57)
Rear driveshaft		
Type		Constant velocity joint

83U09X-023

## TROUBLESHOOTING GUIDE

### FRONT AXLE

Problem	Possible Cause	Remedy
<b>Steering wheel vibration</b>	Improperly adjusted wheel bearing Worn or damaged wheel bearing	Adjust Replace
<b>Pulls or one-sided braking</b>	Improperly adjusted wheel bearing Worn or damaged wheel bearing	Adjust Replace
<b>Excessive steering wheel play</b>	Improperly adjusted wheel bearing	Adjust

63G09X-307

### REAR AXLE

Problem	Possible Cause	Remedy
<b>Abnormal noise</b>	Bent bearing housing Bent driveshaft Worn or damaged wheel bearing Worn driveshaft spline	Replace Replace Replace Replace
<b>Oil leakage</b>	Worn or damaged oil seal	Replace

63G09X-308

## REAR DIFFERENTIAL

Problem	Possible Cause	Remedy
<b>Abnormal noise</b>	Insufficient differential oil Incorrect differential oil Improperly adjusted ring gear backlash Poor contact of ring gear teeth Worn or damaged side bearing Worn or damaged ring gear Worn or damaged drive pinion bearing Worn or damaged pinion and side gear Seizure of side gear and case Worn side gear spline Worn pinion shaft Loose companion flange nut Worn thrust washer Improperly adjusted side bearing preload Improperly adjusted drive pinion bearing preload Worn output shaft spline	Add oil Replace Adjust Adjust Replace Replace Replace Replace Replace Replace Replace Tighten Replace Adjust Adjust Replace
<b>Heat build-up</b>	Insufficient differential oil Insufficient gear backlash Excessive bearing preload	Add oil Adjust Adjust
<b>Oil leakage</b>	Excessive differential oil Clogged air breather Loose tightened differential carrier Worn or damaged oil seal	Remove oil Repair Tighten or repair Replace
<b>No differential operation</b>	Misassembled	Repair

63G09X-309

## FRONT DRIVESHAFT

Problem	Possible Cause	Remedy
<b>Abnormal noise from driveshaft</b>	Incorrect synchronization Worn or seized joint Insufficient grease in joint or spline Excessive backlash on spline Damaged or worn ball bearing	Replace Replace Replenish or replace Replace Replace
<b>Grease leakage from boot</b>	Damaged or broken boot Loose boot band Excessive grease	Replace Replace Repair

63G09X-310

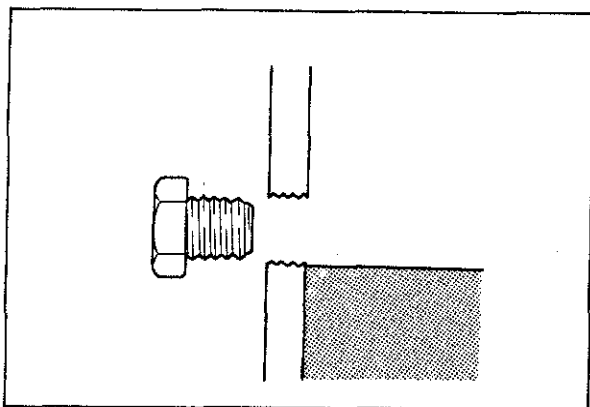

63G09X-314

## REAR DIFFERENTIAL

### ON-VEHICLE CHECK

#### Checking Rear Differential Oil Level

Remove the oil fill plug.  
Check that the oil level is near the port.  
If the level is low, add the specified oil.

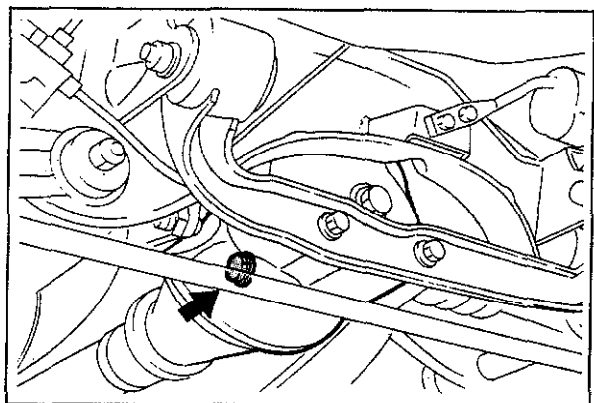

63G09X-315

### ON-VEHICLE MAINTENANCE

#### Replacement of Oil Seals (Companion Flange and Output Shaft)

1. Jack up the vehicle and support it with safety stands.
2. Drain the differential gear oil.

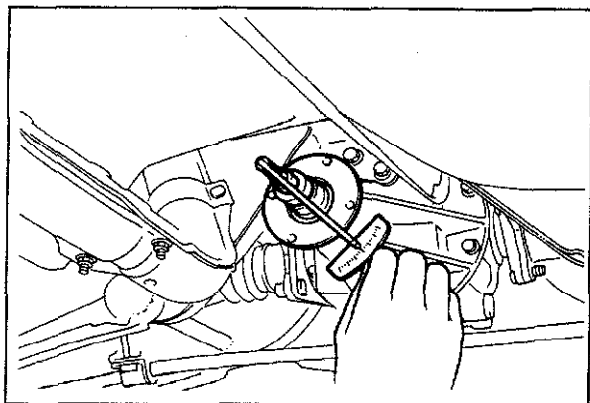

63G09X-316

#### Companion flange oil seal

1. Remove the propeller shaft. (Refer to Section 8)
2. Before loosening the lock nut, measure the rotation starting torque of the drive pinion (within the range of the drive pinion and ring gear backlash).

#### Note

**Make a notation of this torque, at that time of installation, tighten the lock nut to set this value.**

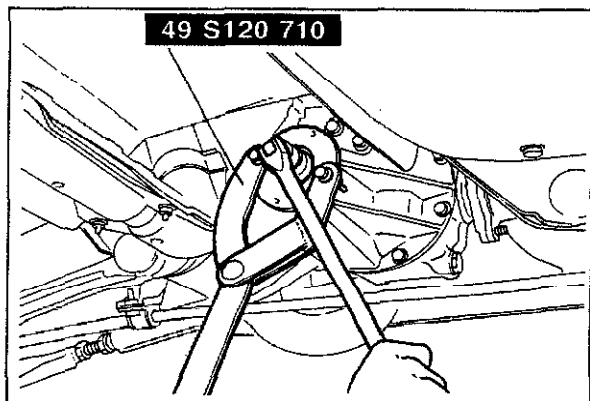

83U09X-038

3. Hold the companion flange with the **SST** and remove the lock nut.

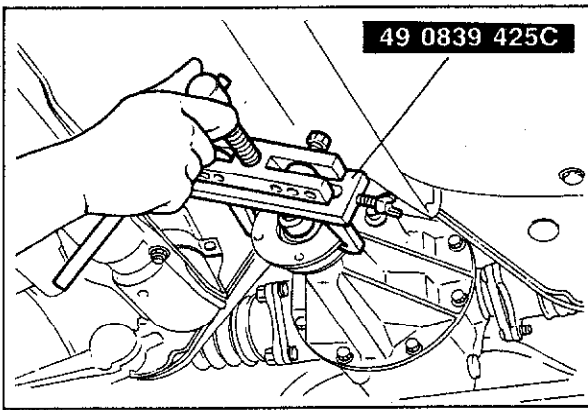

83U09X-039

- Remove the companion flange using **SST**.

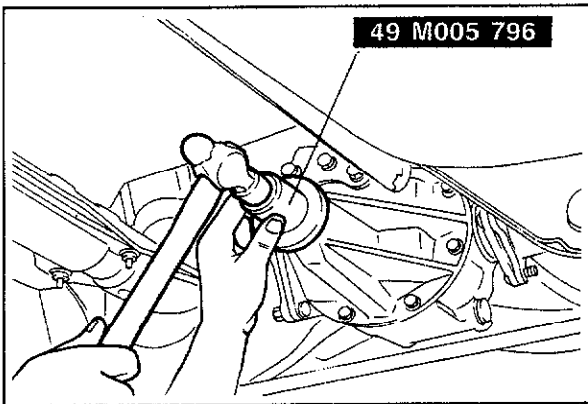

83U09X-040

- Replace the oil seal.  
To install the oil seal using the **SST**.

**Note**

Apply a thin coat of grease (lithium base, NLGI No. 2) to the oil seal lip.

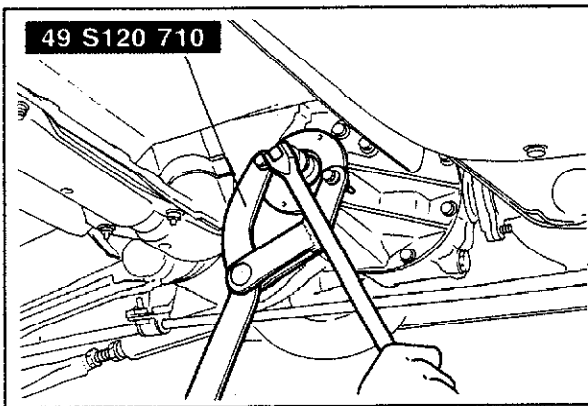

63G09X-320

- Install the companion flange and tighten the lock nut to get the specified starting torque (above step 2).
- Install the propeller shaft.

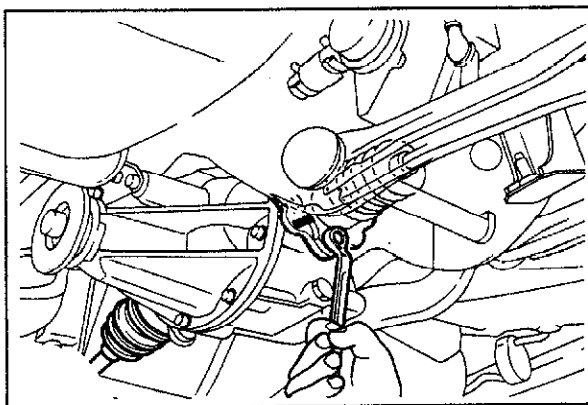

63G09X-321

**Output shaft oil seal**

- Put mating marks on the output shaft and driveshaft and remove the bolts and nuts.

## 9 REAR DIFFERENTIAL

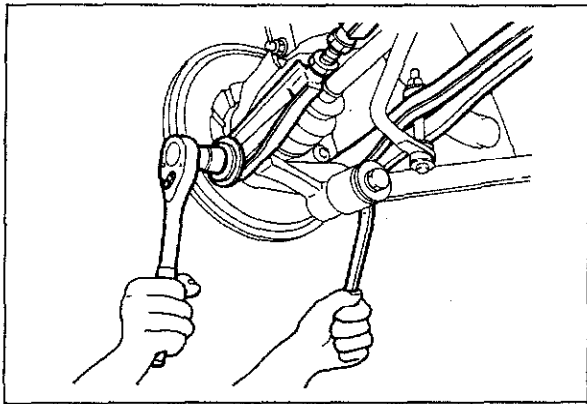

63G09X-322

2. Remove the lateral link.

**Caution**

Be careful that when disconnect the bolt and nut, the lateral link will be bounded.

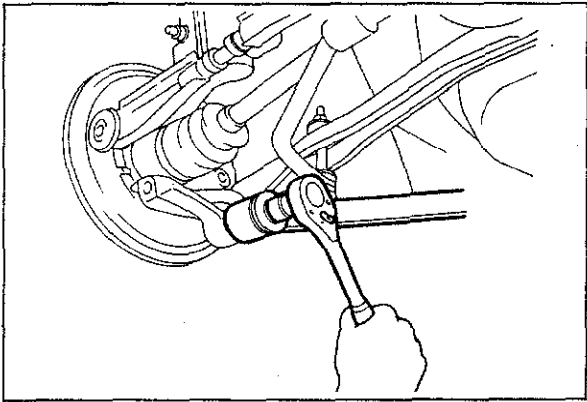

63G09X-323

3. Remove the trailing link.

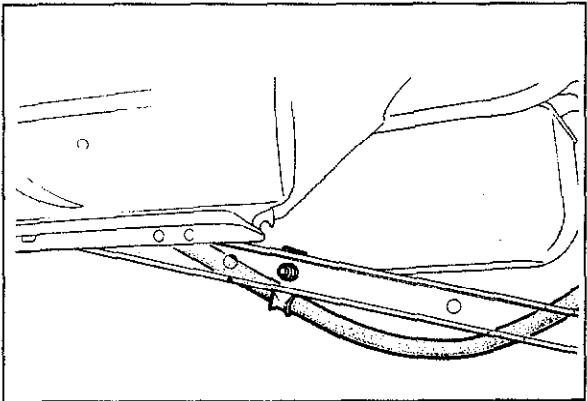

63G09X-324

4. Remove the parking brake cable from trailing link.

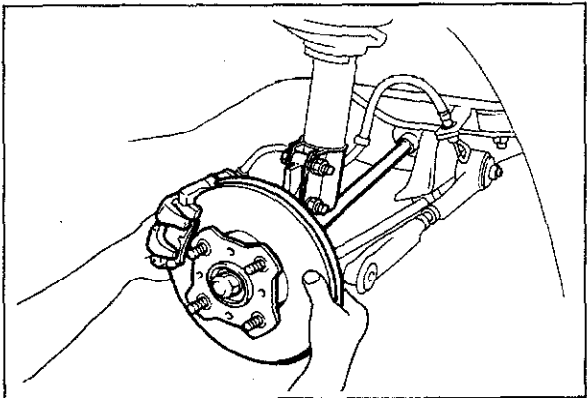

63G09X-325

5. Pull the wheel hub out and separate the driveshaft from the output shaft.



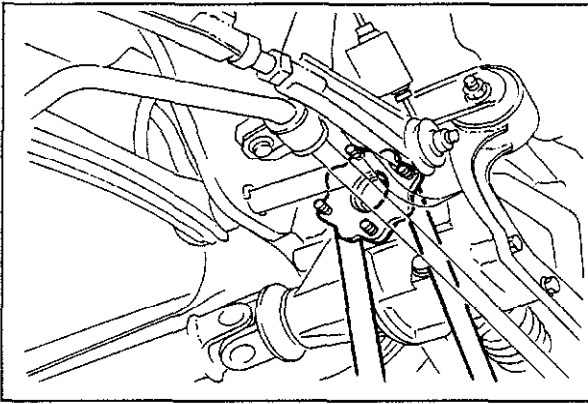

63G09X-326

6. Insert two pry bars between the differential case and the output shaft, remove the output shaft by applying pressure evenly to the pry bars.

**Note**

Use caution during the removal operation, because the shaft may suddenly jump out.

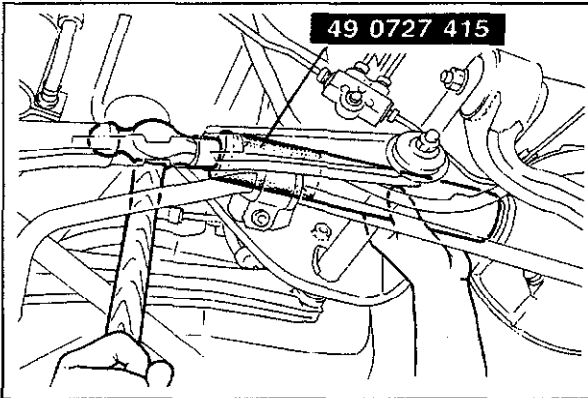

63U09X-041

7. Replace the oil seal, using the SST.

**Note**

Apply a thin coat of grease (lithium base, NLGI No. 2) to the oil seal lip.

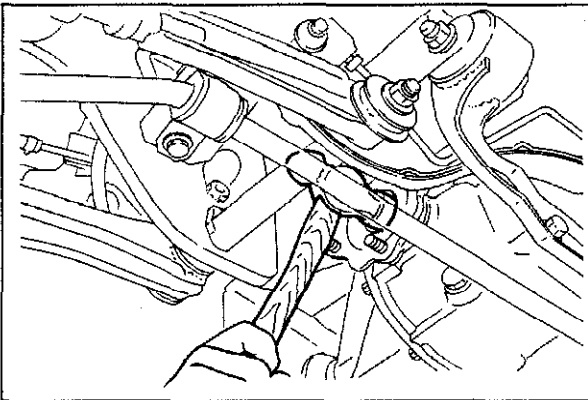

63G09X-328

8. Install the output shaft.

**Note**

Replace the output shaft clip with a new clip.

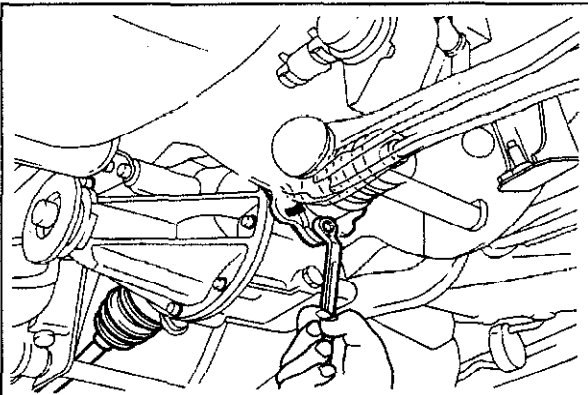

63G09X-329

9. Align the mating marks on the driveshaft and output shaft, and reinstall the driveshaft.
10. Install the parking brake cable.

## 9 REAR DIFFERENTIAL

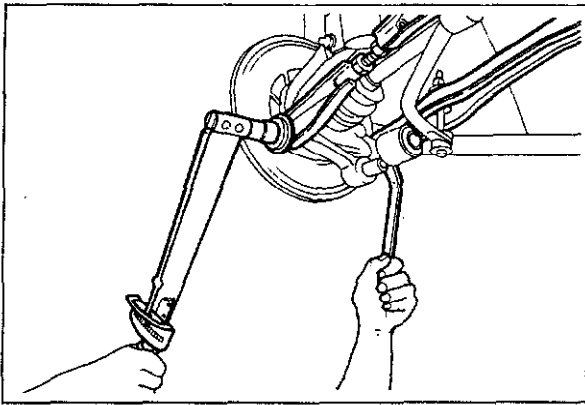

63G09X-330

11. Install the lateral link.

**Tightening torque:**  
63—75 N·m (6.4—7.6 m·kg, 46—55 ft·lb)

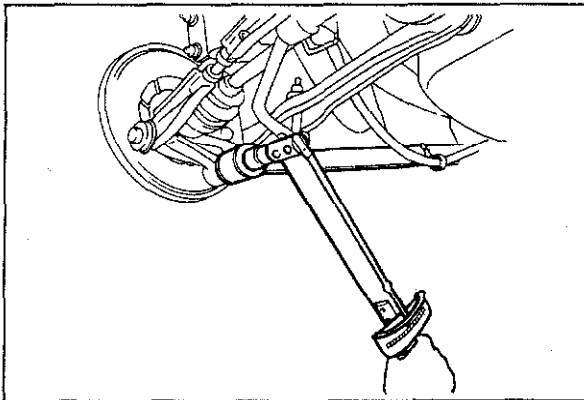

63G09X-331

12. Install the trailing link.

**Tightening torque:**  
93—117 N·m (9.5—11.9 m·kg, 69—86 ft·lb)

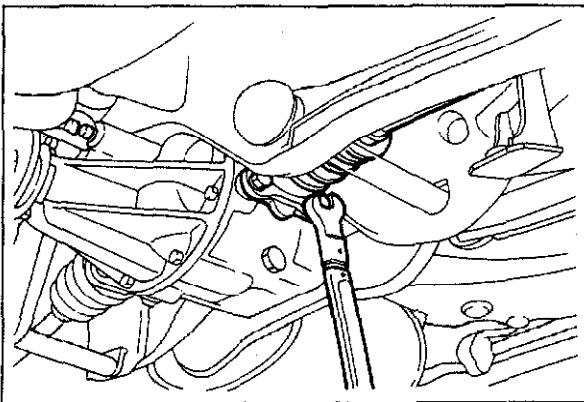

63G09X-332

13. Tighten the driveshaft.

**Tightening torque:**  
49—59 N·m (5.0—6.0 m·kg, 36—43 ft·lb)

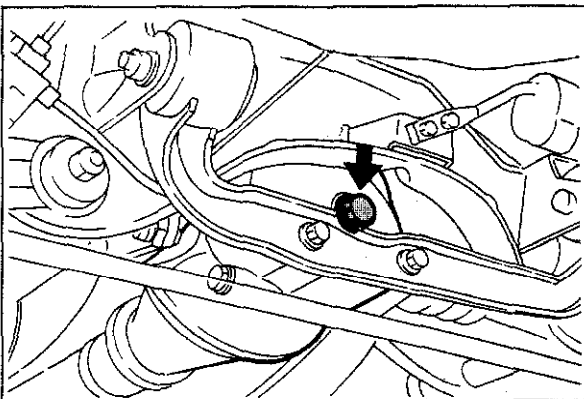

63G09X-333

14. Fill the differential with the correct grade and quantity of oil.

15. Tighten the oil fill plug.

**Tightening torque:**  
39—54 N·m (4.0—5.5 m·kg, 29—40 ft·lb)

## REMOVAL

1. Jack up the rear of the vehicle and support it with safety stands.
2. Drain the differential gear oil.
3. Remove the parts in the sequence shown in the figure.

63U09X-042

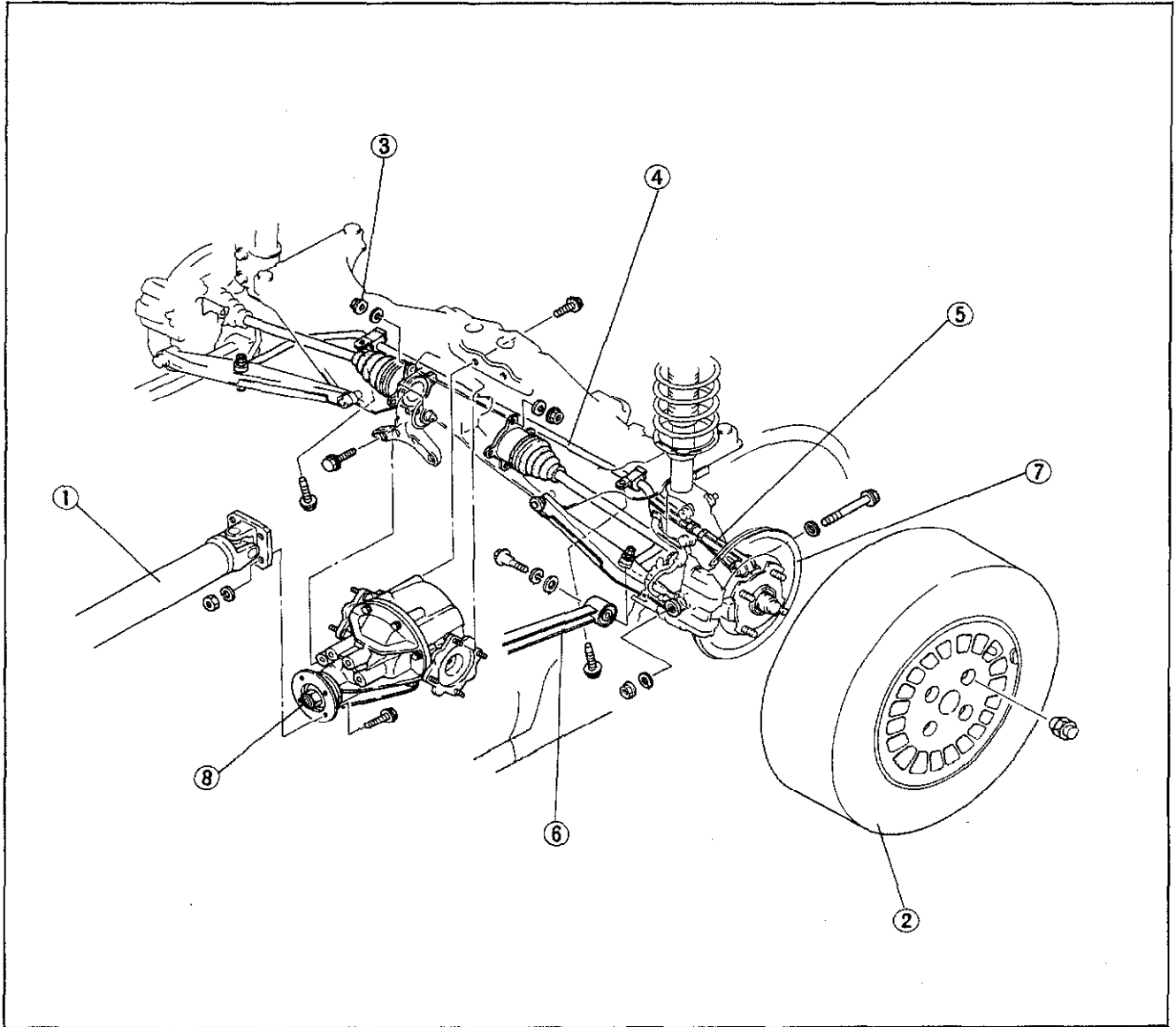

63G09X-335

1. Propeller shaft
2. Wheel
3. Nut
4. Stabilizer

5. Lateral link
6. Trailing link
7. Wheel hub
8. Differential

## 9 REAR DIFFERENTIAL

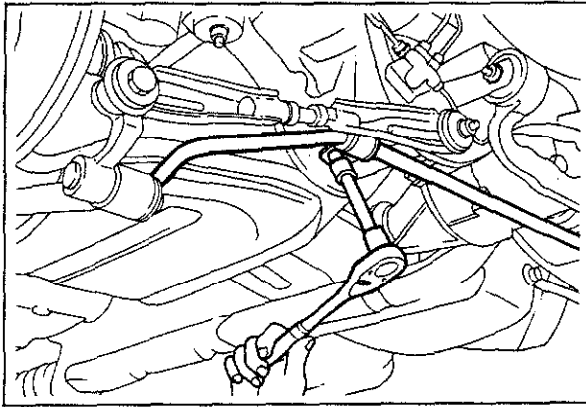

63G09X-336

1. Remove the propeller shaft (Refer to Section 8).
2. Remove the wheels
3. Put mating marks on the output shaft and driveshaft, then remove the nut.
4. Remove the stabilizer from crossmember.

### Caution

Never remove the both ends of the stabilizer.

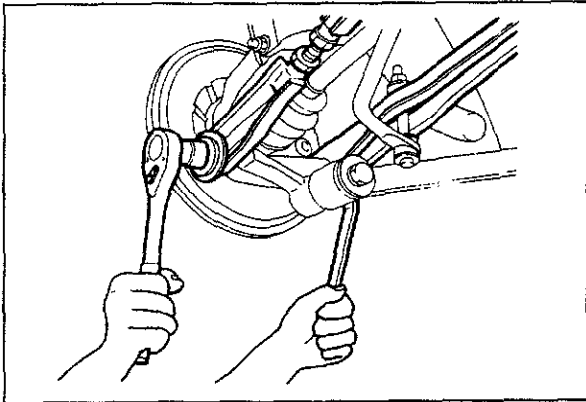

63G09X-337

5. Remove the lateral link.

### Caution

Be careful that when disconnect the bolt and nut, the lateral link will be bounded.

6. Remove the trailing link.

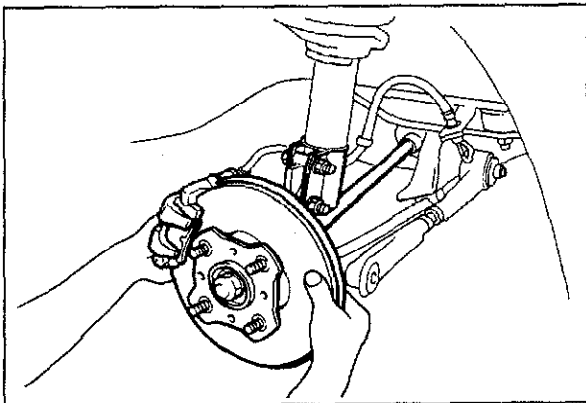

63G09X-338

7. Pull the wheel hub out, and separate the driveshaft from the output shaft.

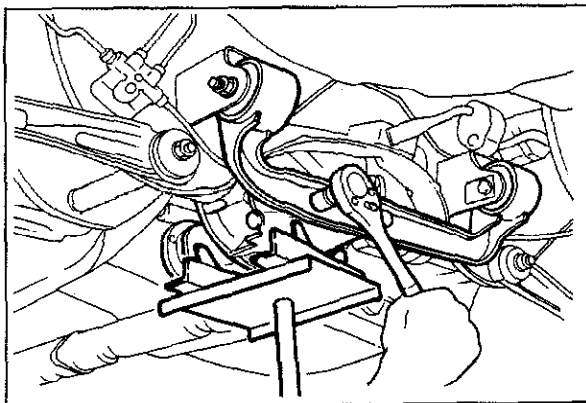

63G09X-339

8. Support the differential assembly with a jack, remove the assembly.

## DISASSEMBLY

Disassemble in the sequence shown in the figure.

63G09X-340

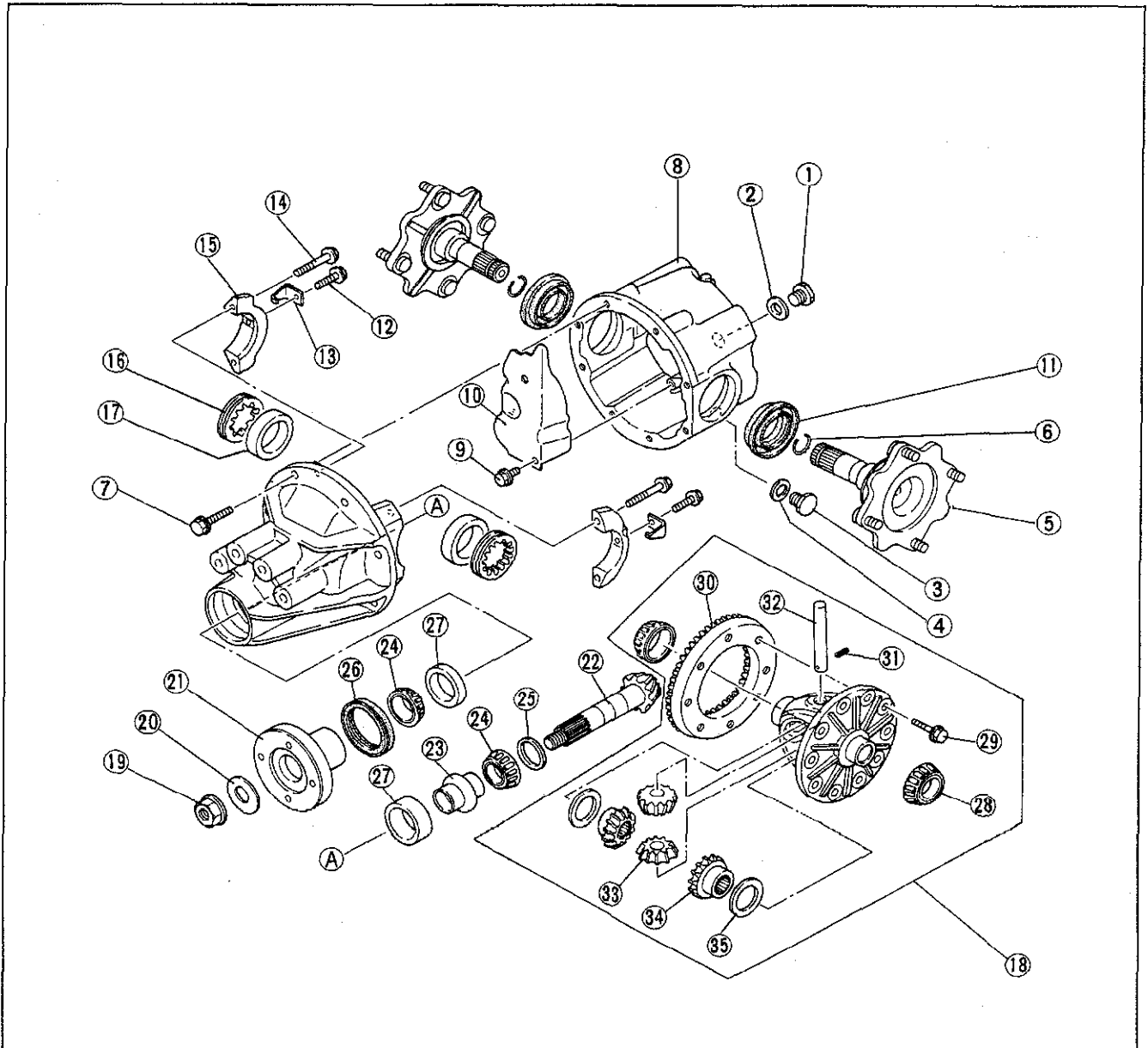

63G09X-341

- |                         |                             |                        |
|-------------------------|-----------------------------|------------------------|
| 1. Oil fill plug        | 13. Lock plate              | 25. Spacer             |
| 2. Gasket               | 14. Bolt                    | 26. Oil seal           |
| 3. Magnet plug          | 15. Bearing cap             | 27. Bearing outer race |
| 4. Gasket               | 16. Adjust screw            | 28. Bearing inner race |
| 5. Output shaft         | 17. Bearing outer race      | 29. Bolt               |
| 6. Clip                 | 18. Differential gear ass'y | 30. Ring gear          |
| 7. Bolt                 | 19. Lock nut                | 31. Knock pin          |
| 8. Differential housing | 20. Washer                  | 32. Pinion shaft       |
| 9. Bolt                 | 21. Companion flange        | 33. Pinion gear        |
| 10. Baffle plate        | 22. Drive pinion            | 34. Side gear          |
| 11. Oil seal            | 23. Collapsible spacer      | 35. Thrust washer      |
| 12. Bolt                | 24. Bearing inner race      |                        |

## 9 REAR DIFFERENTIAL

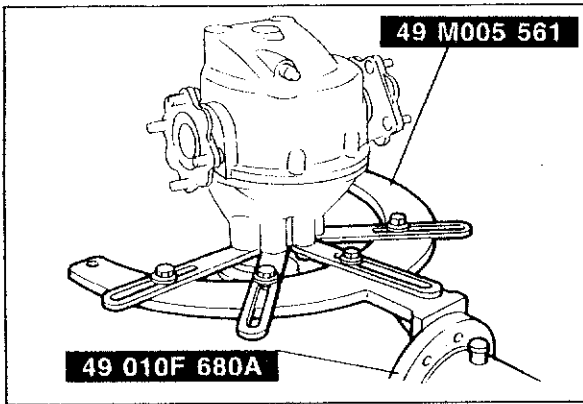

83U09X-043

Mount the differential gear assembly on the **SST**.

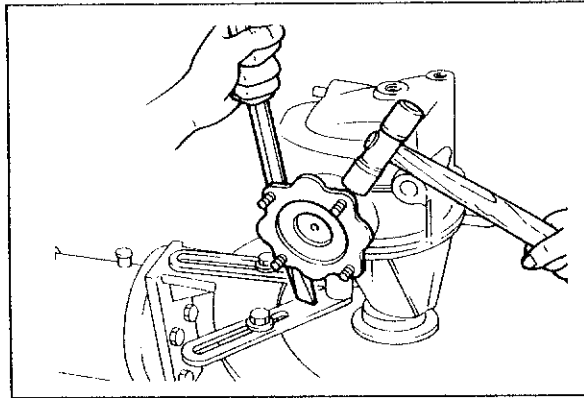

### Output Shaft

Tap the output shaft with a plastic hammer as shown in the figure to remove.

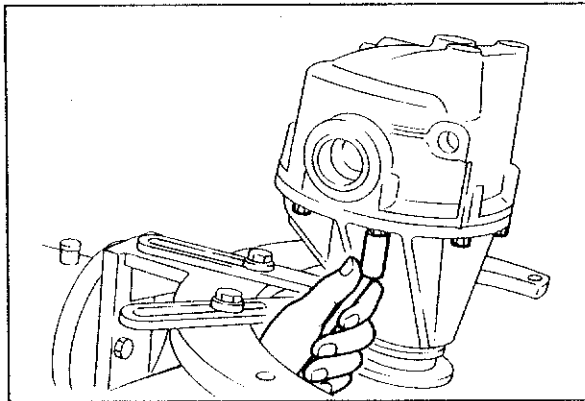

### Differential Housing

Remove the differential housing.

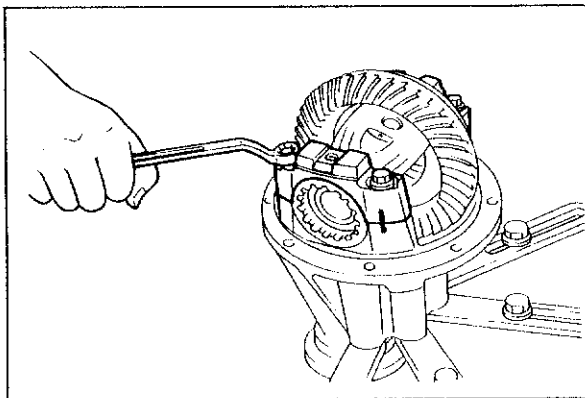

### Bearing Cap

Mark the carrier one bearing cap and adjuster for proper reassembly.

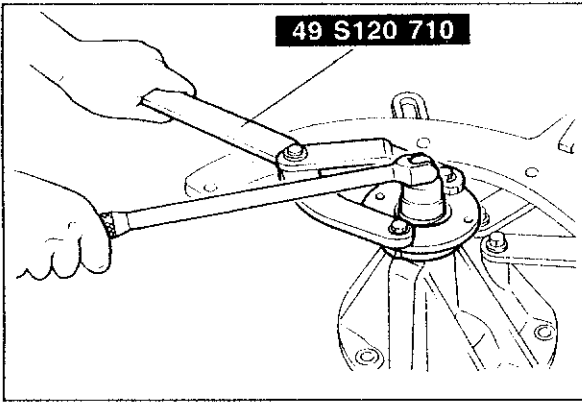

83U09X-044

### Lock Nut

Hold the companion flange with the **SST** and remove the lock nut.

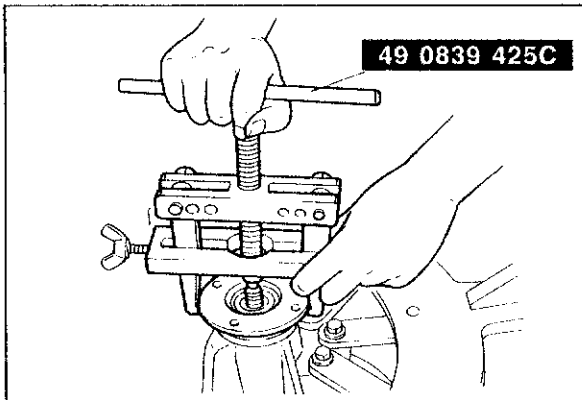

83U09X-045

### Companion Flange

Pull the companion flange off using the **SST**.

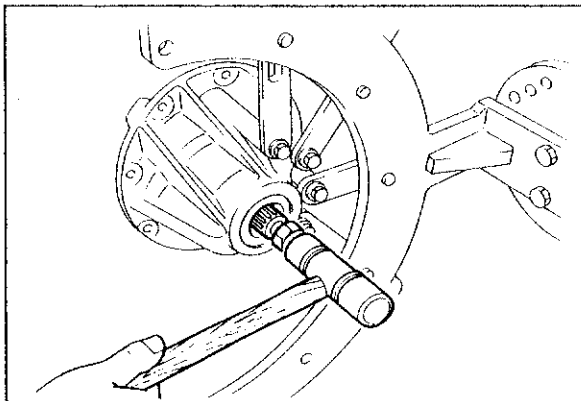

63G09X-349

### Drive Pinion

Push the drive pinion out by attaching a miscellaneous lock nut to the drive pinion, and tapping it with a brass hammer.

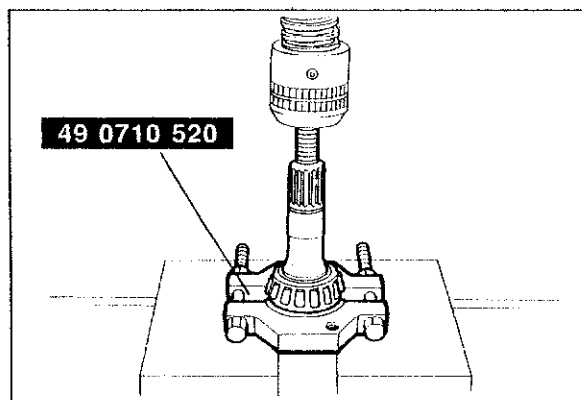

83U09X-046

### Rear Bearing

Remove the bearing using the **SST**.

### Note

Support the drive pinion by hand so that it will not fall.

# 9 REAR DIFFERENTIAL

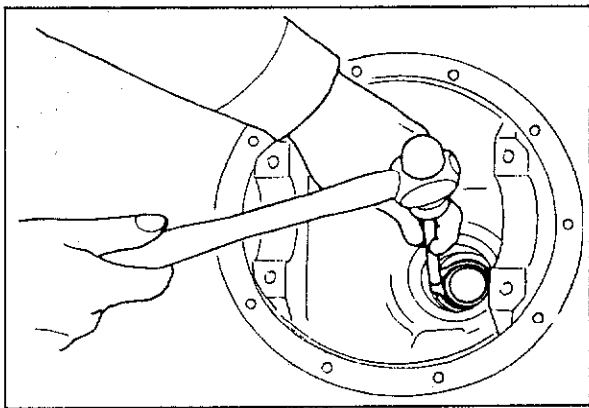

63G09X-351

## Bearing Outer Race

Remove the bearing outer races by using the two grooves in the carrier and tapping the races alternately.

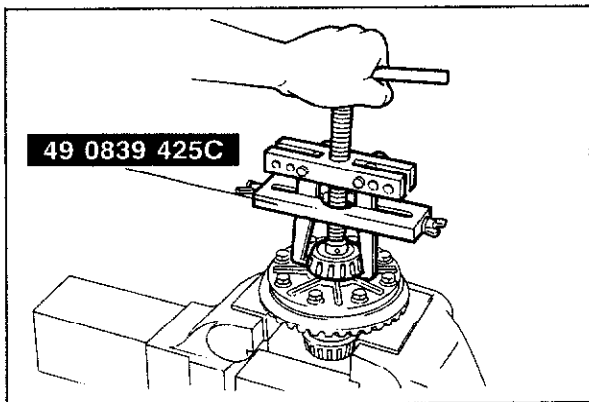

83U09X-047

## Side Bearing

Using parts in the **SST**, remove the side bearings from the gear case.

### Caution

Identify each one of the bearings so that they can later be re-installed in the same position.

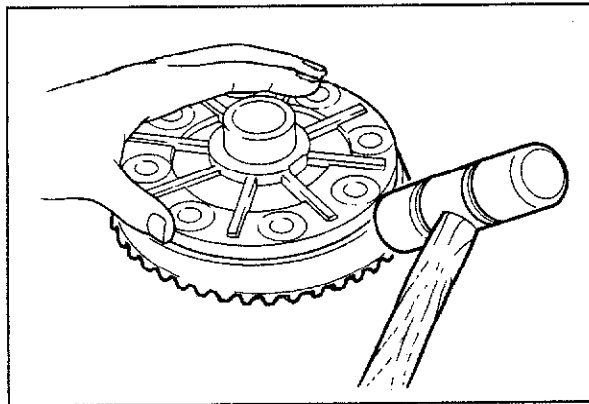

63G09X-353

## Ring Gear

Remove the ring gear using a plastic hammer.

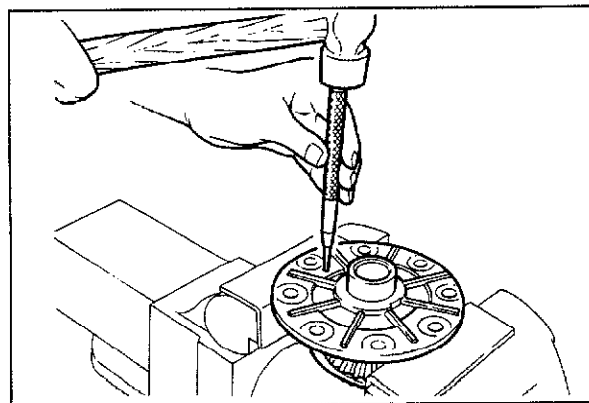

63G09X-354

## Knock Pin

Secure the gear case in a vise and remove the knock pin.

### Caution

Insert the punch from the knock pin hole opposite the ring gear side.



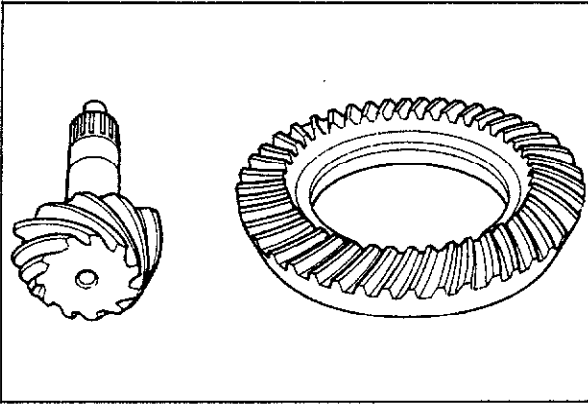

63G09X-355

## INSPECTION

Check the following points, if a problem is found, replace the part.

### Drive Pinion and Ring Gear

Poor contact, wear or damage.

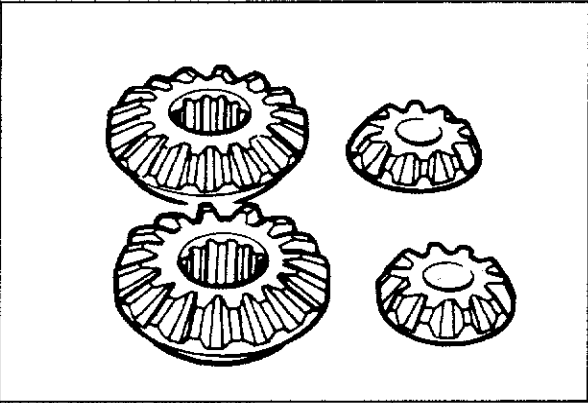

63G09X-356

### Differential Gear

1. Check the differential side gears and pinion gears for cracks, chipped teeth or damage.
2. Check the differential bearings and pinion bearings for wear, flaking or damage.

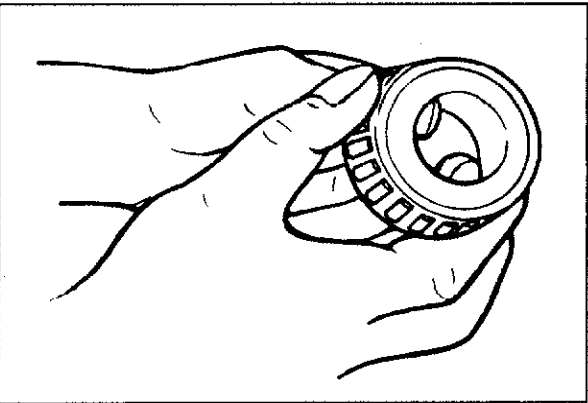

63G09X-357

### Bearing

Check the bearings for wear, damage or seizure.

### Caution

If replacement is necessary, replace the bearings as a set.

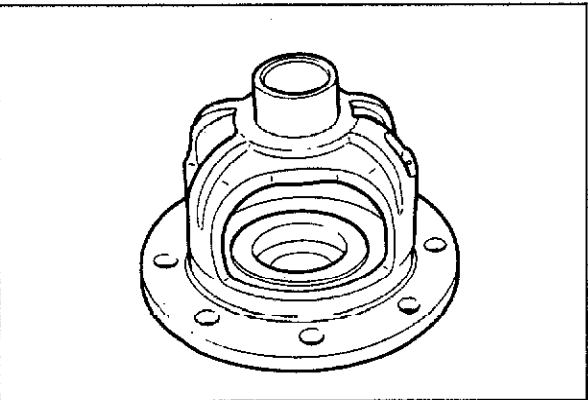

63G09X-358

### Gear Case

Check for cracks, damage and wear.

## 9 REAR DIFFERENTIAL

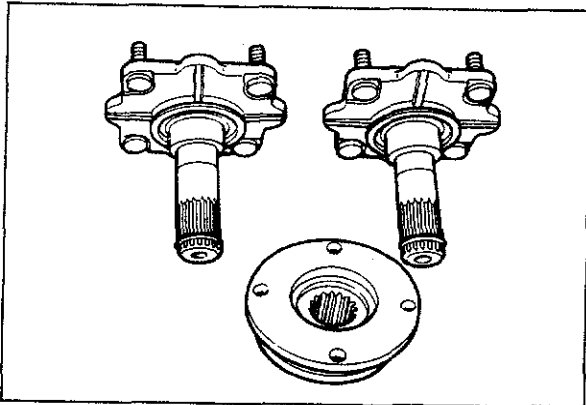

63G09X-359

**Companion Flange and Output Shaft**  
Check for worn splines, damage and cracks.

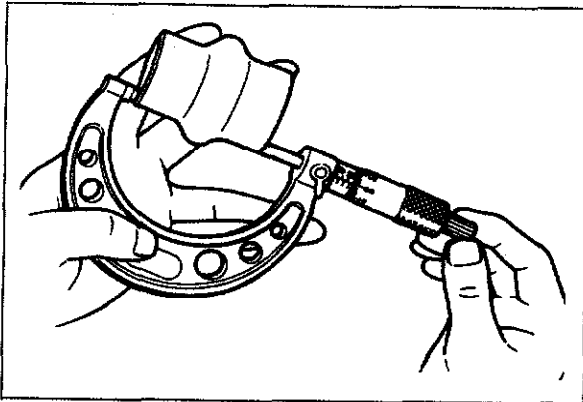

83U09X-048

**Collapsible Spacer**  
Measure the length of the collapsible spacer.

**Standard length:**  
43.35—43.65 mm (1.707—1.719 in)

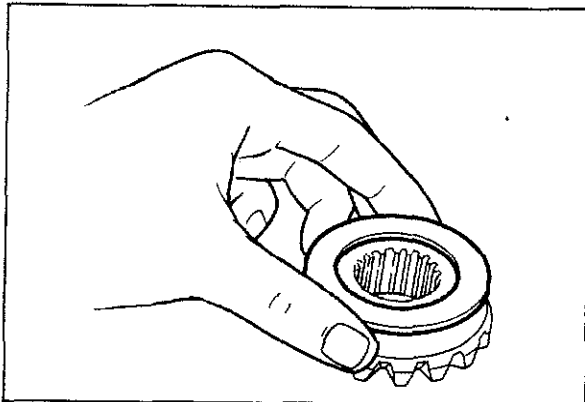

63G09X-361

### ASSEMBLY

Assemble in the reverse order of disassembly.

#### Side Gear and Pinion Gear

1. Install the thrust washers on the side gears and install them in the gear case.

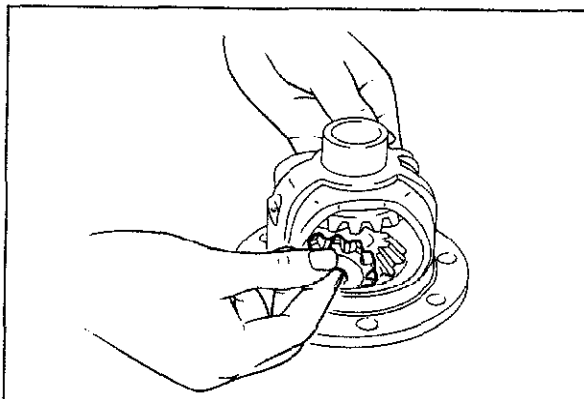

63G09X-362

2. Through the openings of the gear case, insert the pinion gears exactly **180** degrees opposite each other.
3. Rotate the gears **90** degrees so that the pinion gears align with the pinion shaft holes in the gear case.
4. Insert the pinion shaft.
5. Insert the output shaft.

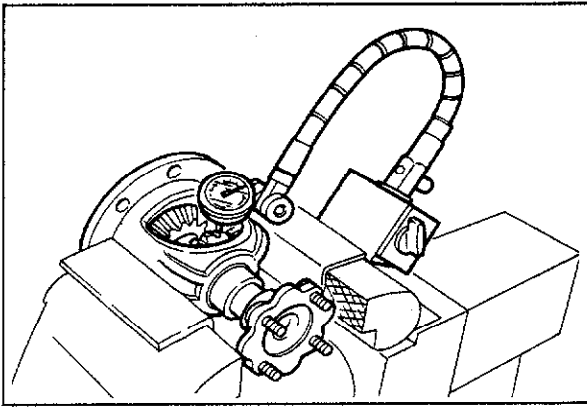

67G09X-363

6. Check the backlash of the side gear and pinion gear. Adjust by inserting proper thickness thrust washer at both sides.

**Standard backlash: 0—0.1 mm (0—0.004 in)**

**Thrust washer thickness:**

Identification mark	Thickness
0	2.00 mm (0.0787 in)
1	2.10 mm (0.0827 in)
2	2.20 mm (0.0866 in)

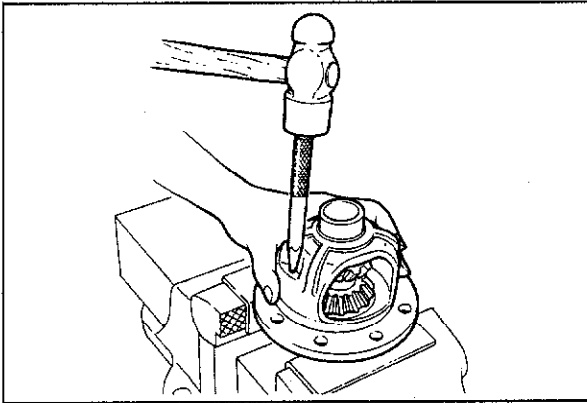

63G09X-364

### Knock Pin

Install the knock pin to secure the pinion shaft. Stake the knock pin into position with a punch to prevent it from coming out.

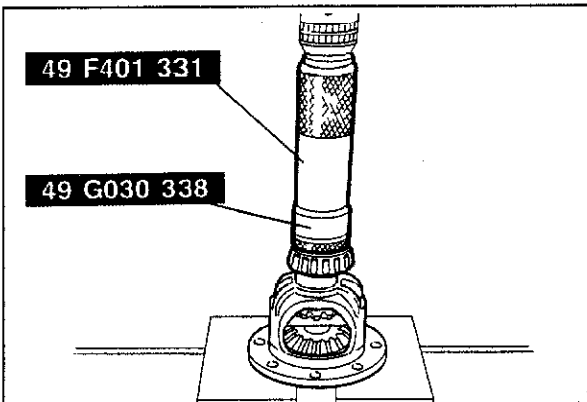

83U09X-049

### Side Bearing

Press the side bearing on using the **SST**.

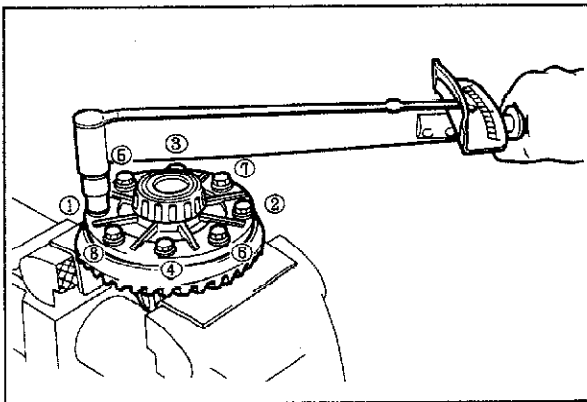

63G09X-366

### Ring Gear

Install the ring gear to the gear case.

**Tightening torque:**

**69—83 N·m (7.0—8.5 m·kg, 51—61 ft·lb)**

# 9 REAR DIFFERENTIAL

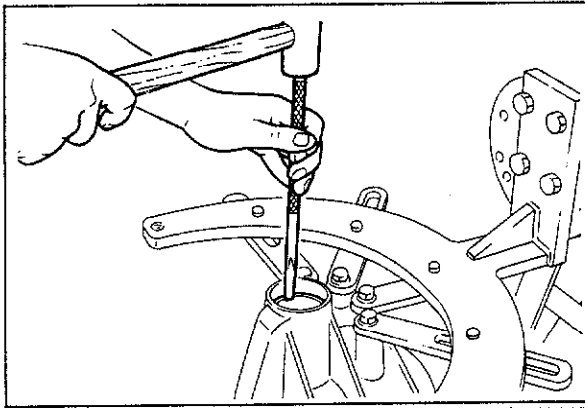

63G09X-367

## Adjustment of Pinion Height

1. Install the front and rear bearing outer races using a brass drift and a hammer.

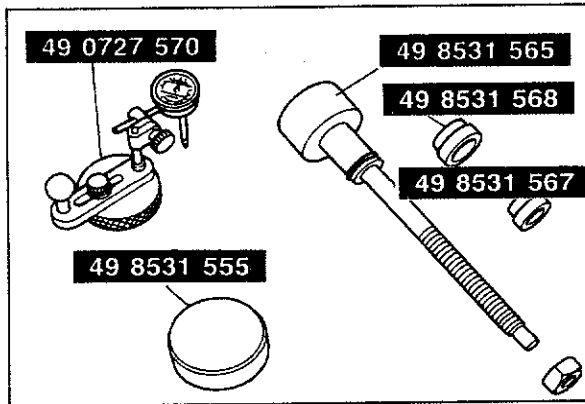

83U09X-050

2. Adjust drive pinion height as follows using the **SST**.

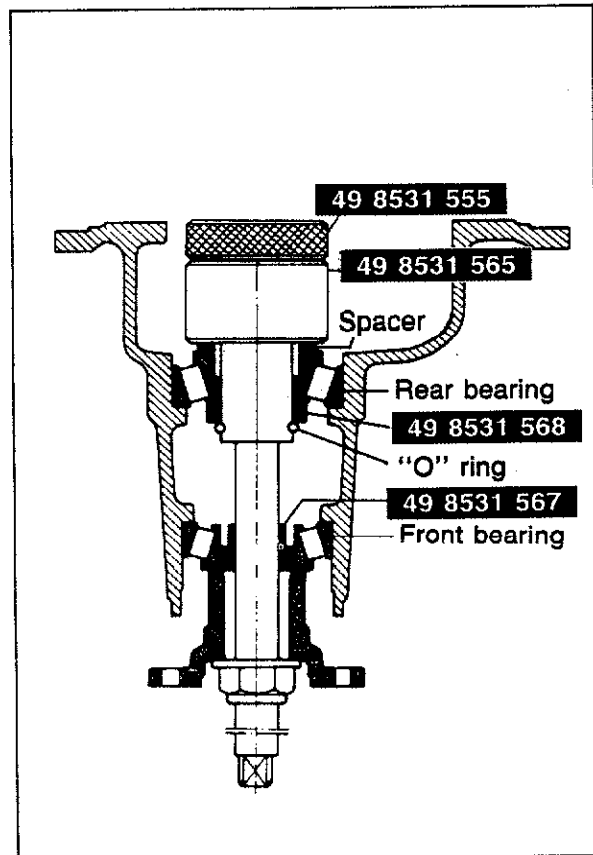

83U09X-051

3. Fit the spacer, rear bearing, and **SST**. Secure the collar with the "O" ring. Then install this to the carrier.

4. Attach the front bearing, **SST**, companion flange, washer, and nut to the drive pinion model.

### Note

a) Use the same spacer and nut which were removed at disassembly.

b) Be sure to install collars A and B in the correct position and facing in the correct direction.

5. Tighten the nut to the extent that the drive pinion model can be turned by hand.

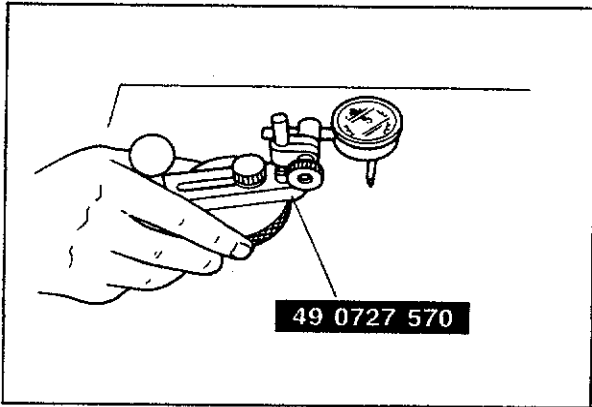

63G09X-370

6. Place the **SST** on the surface plate and set the dial indicator to "Zero".

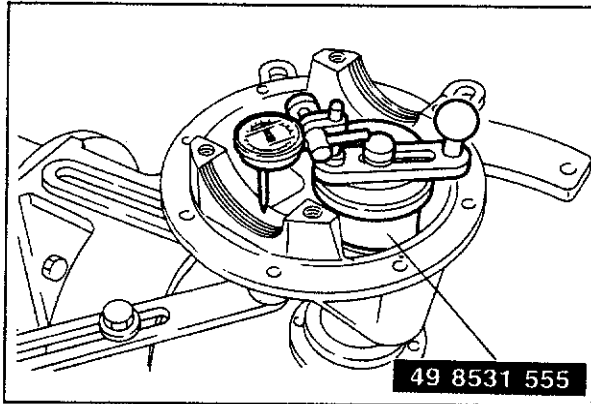

83U09X-052

7. Place the **SST**.

8. Place the feeler of the dial indicator so that it contacts where the side bearing is installed in the carrier. Measure the lowest position on both the left and the right sides.

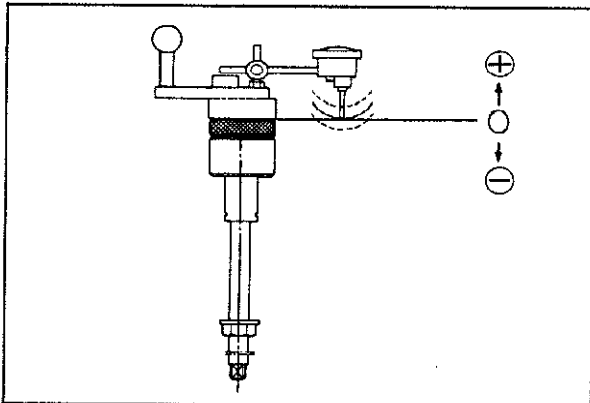

63G09X-372

9. Add the two (left and right) values obtained by the measurements taken in step 8 and divide the total by 2.

**Standard: 0 mm (0 in)**

Mark	Thickness	Mark	Thickness
08	3.08 mm (0.1213 in)	29	3.29 mm (0.1295 in)
11	3.11 mm (0.1224 in)	32	3.32 mm (0.1307 in)
14	3.14 mm (0.1236 in)	35	3.35 mm (0.1319 in)
17	3.17 mm (0.1248 in)	38	3.38 mm (0.1331 in)
20	3.20 mm (0.1260 in)	41	3.41 mm (0.1343 in)
23	3.23 mm (0.1271 in)	44	3.44 mm (0.1354 in)
26	3.26 mm (0.1283 in)	47	3.47 mm (0.1366 in)

63G09X-373

10. If it is not within specification, adjust the pinion height by selection of a spacer.

**Note**

**The spacer thicknesses are available in 0.03 mm. Select the spacer thickness that is closest to that necessary.**

# 9 REAR DIFFERENTIAL

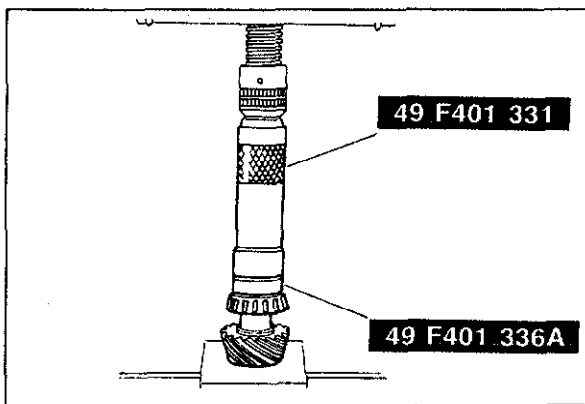

83U09X-053

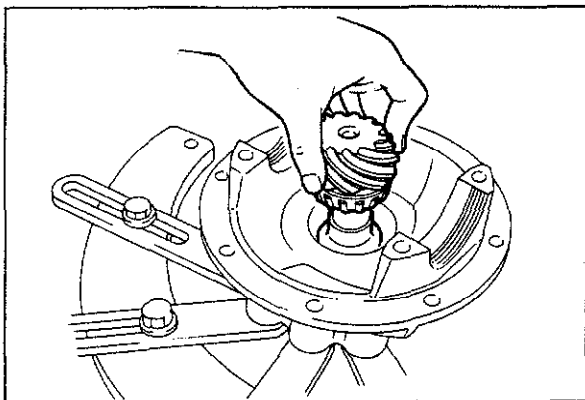

63G09X-375

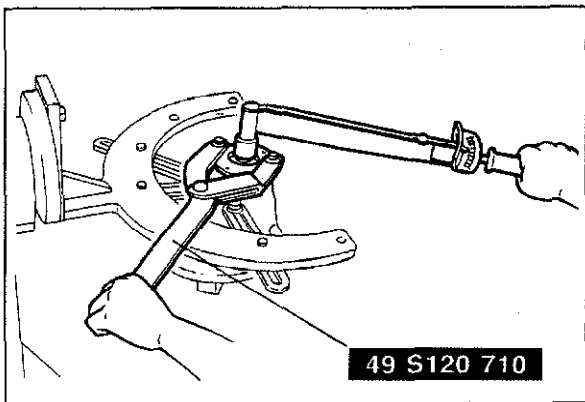

63G09X-376

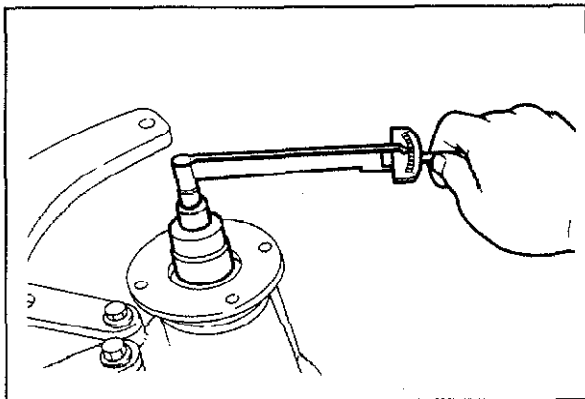

63G09X-377

## Adjustment of Drive Pinion Preload

1. Install the spacer.
2. Press the rear bearing on by using the **SST**.

### Caution

- a) Press on until the force required suddenly increases.
- b) Install the spacer selected for the pinion height adjustment, taking care that the installation direction is correct.

3. Install the collapsible spacer.
4. Install the drive pinion assembly.

5. Install the companion flange, and tighten the lock nut.

### Caution

Do not install the oil seal.

### Tightening torque:

118—177 N·m (12—18 m·kg, 87—130 ft·lb)

6. Turn the companion flange by hand to seat the bearing.
7. Measure the drive pinion preload.  
If the specified preload can not be obtained, replace the collapsible spacer with a new one and check again.

### Preload: 0.3—0.7 N·m

(3—7 cm·kg, 2.6—6.1 in·lb)

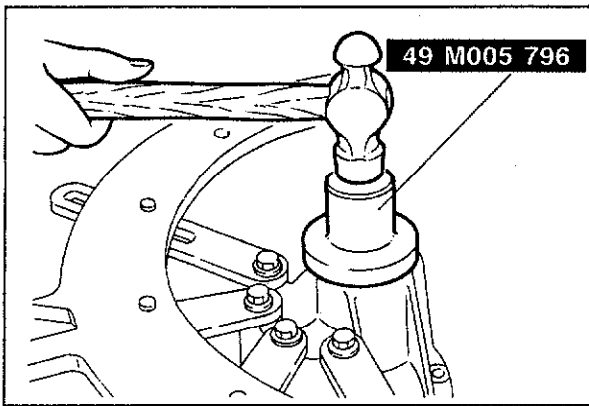

83U09X-054

8. Remove the nut, washer and companion flange.
9. Tap the oil seal into the differential carrier using the **SST**.

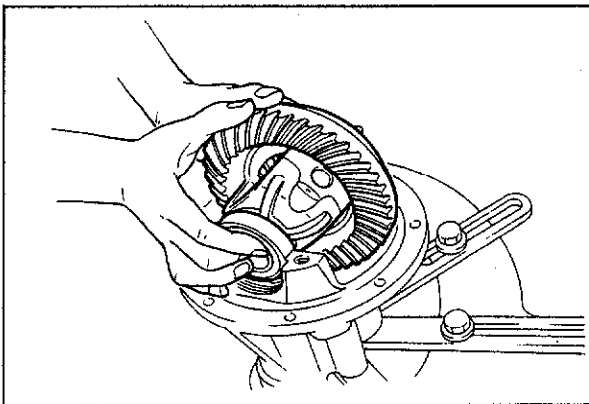

63G09X-379

### Adjustment of Backlash

1. Install the differential gear assembly in the carrier.
2. Note the identification marks on the adjusters and install the adjusters to their respective side.
3. Install the differential bearing caps making sure that the identification marks on the caps correspond with those on the carrier.

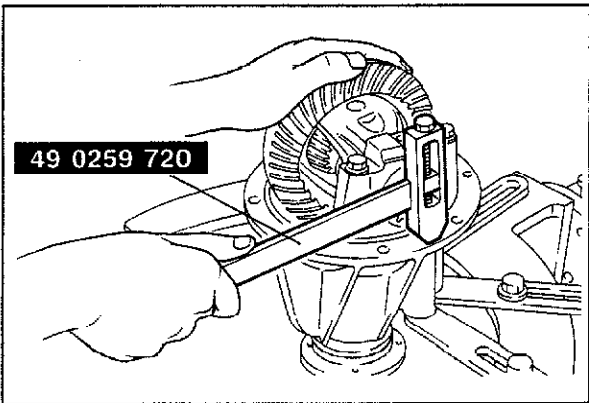

83U09X-055

4. Mark the ring at four points at approx. 90° intervals. Mount a dial indicator to the carrier so that the feeler comes in contact at a right angle with one of the ring gear teeth.
5. Turn both bearing adjusters equally until the backlash is **0.15—0.17 mm (0.0059—0.0067 in)** using the **SST**.

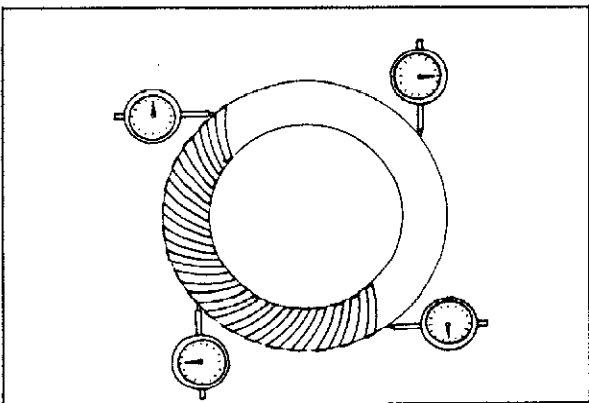

63G09X-381

6. Check the backlash at the three other marked points and make sure that the minimum backlash is above **0.05 mm (0.002 in)**, and the difference between the maximum and minimum backlash is less than **0.07 mm (0.0028 in)**.

# 9 REAR DIFFERENTIAL

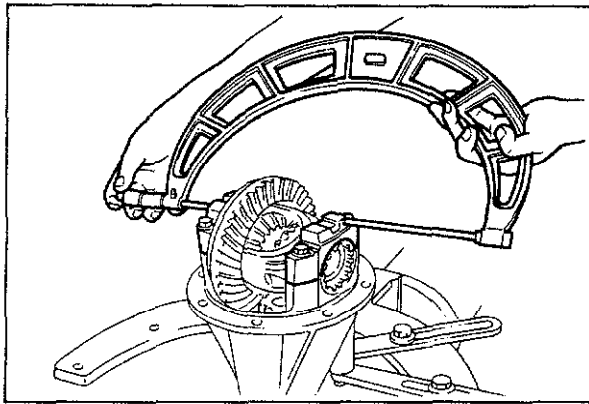

83U09X-056

7. Tighten the adjusters equally until the distance between the pilot sections on the bearing caps is **150.14—150.20 mm (5.9110 —5.9134 in)** as shown in the figure.

### Note

**When adjusting the differential bearing preload, care must be taken not to affect the backlash of the drive pinion and ring gear.**

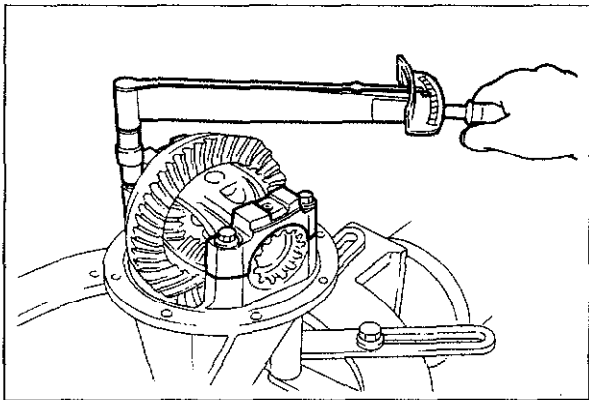

63G09X-383

8. Tighten the bearing cap bolts.

### Tightening torque:

**37—52 N·m (3.8—5.3 m·kg, 27—38 ft·lb)**

9. Install the adjuster lock plates on the bearing caps to prevent the adjusters from loosening.

### Tightening torque:

**19—26 N·m (1.9—2.6 m·kg, 14—19 ft·lb)**

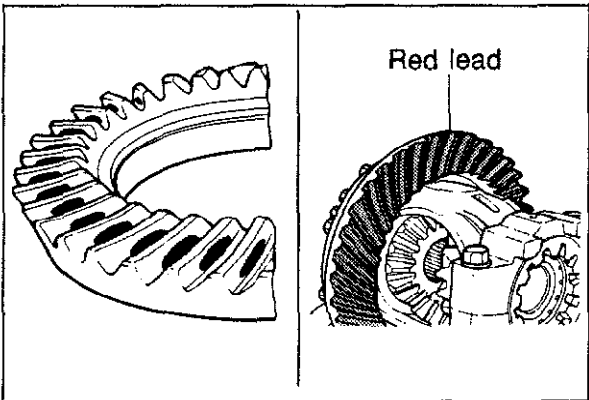

63G09X-384

### Inspection and Adjustment of Teeth Contact

1. Coat both surfaces of 6—8 teeth of the ring gear uniformly with a thin coat of red lead.
2. While moving the ring gear back and forth by hand, rotate the drive pinion several times and check the tooth contact.
3. If the tooth contact is good, wipe off the red lead.
4. If it is not good, adjust the pinion height, and then adjust the backlash.

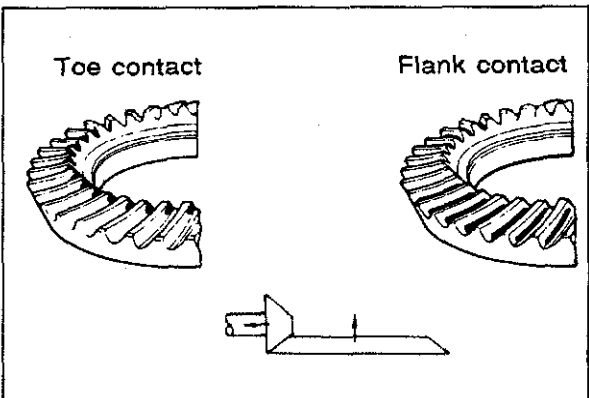

63G09X-385

- (1) Toe and flank contact  
Replace the spacer with a thinner one to move the drive pinion outward.



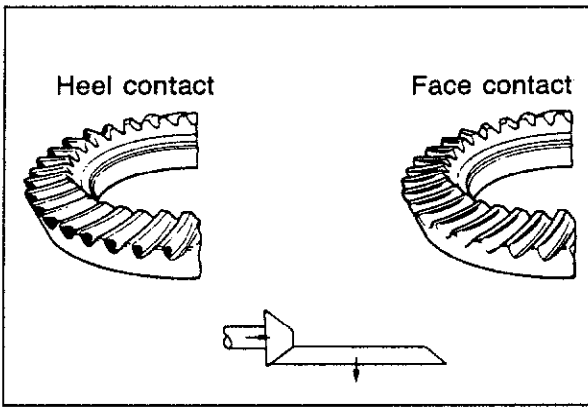

- (2) Heel and face contact  
Replace the spacer with a thicker one to bring the drive pinion in.

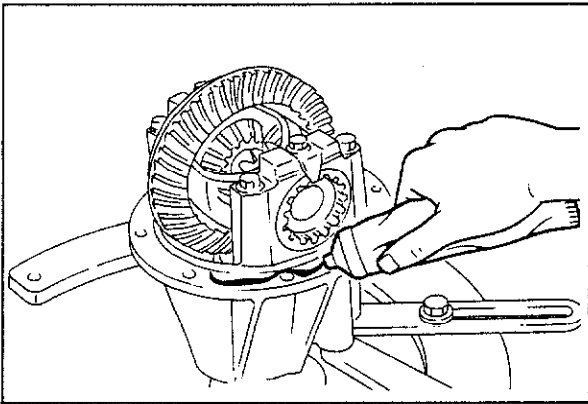

### Differential Housing

1. Coat both surfaces with a sealing compound.

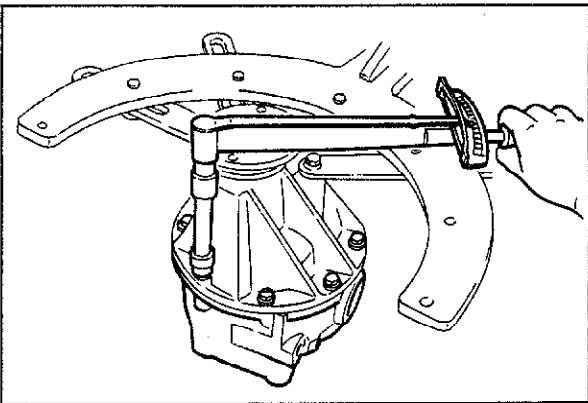

2. Install the differential housing.

### Tightening torque:

23—26 N·m (2.3—2.7 m·kg, 17—20 ft·lb)

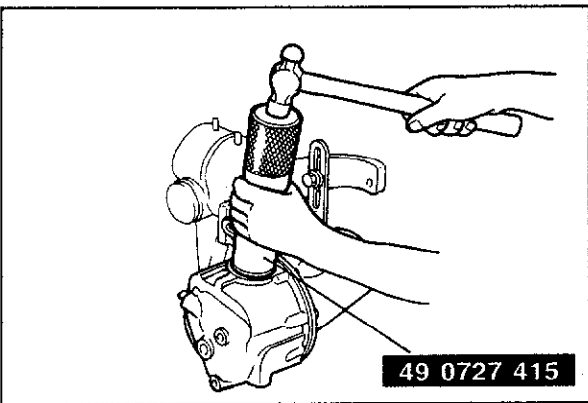

### Oil Seal

Install a new oil seal using the SST.

# 9 REAR DIFFERENTIAL

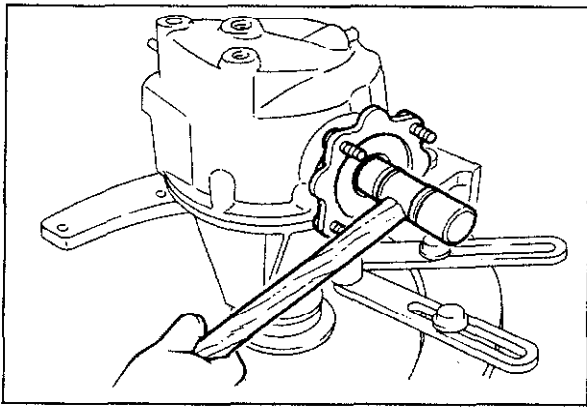

63G09X-390

**Output Shaft**  
Install the output shaft.

**Note**  
Replace the output shaft clip with a new clip.

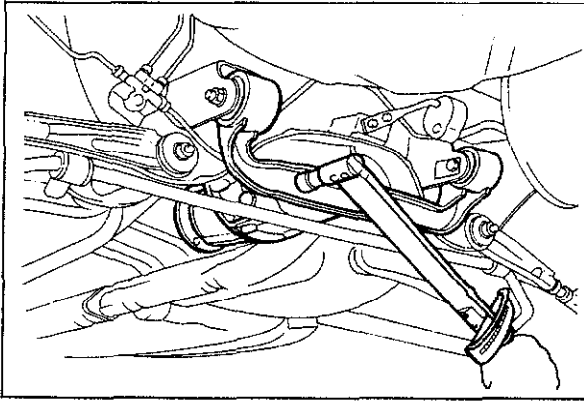

63G09X-391

**INSTALLATION**  
1. Install the differential assembly.

**Tightening torque:**  
Front: 45—68 N·m  
(4.6—6.9 m·kg, 33—50 ft·lb)  
Rear: 108—131 N·m  
(11.0—13.4 m·kg, 80—97 ft·lb)

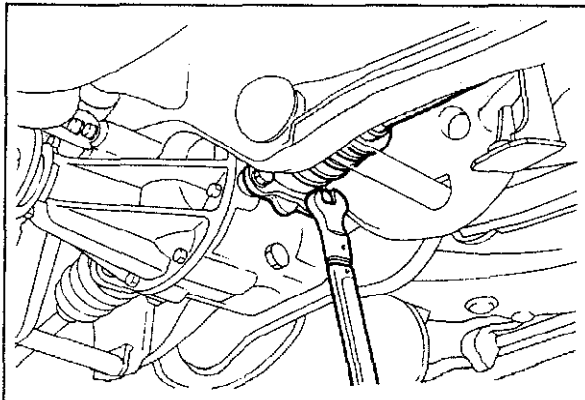

63G09X-392

2. Align the mating marks on the driveshaft and output shaft, then install the driveshaft.

**Tightening torque:**  
49—59 N·m (5.0—6.0 m·kg, 36—43 ft·lb)

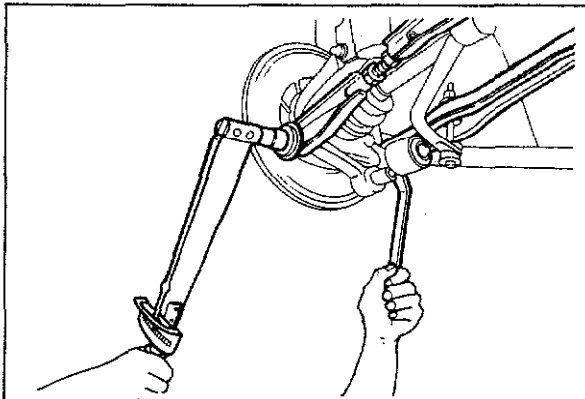

63G09X-393

3. Install the lateral link.

**Tightening torque:**  
63—75 N·m (6.4—7.6 m·kg, 46—55 ft·lb)

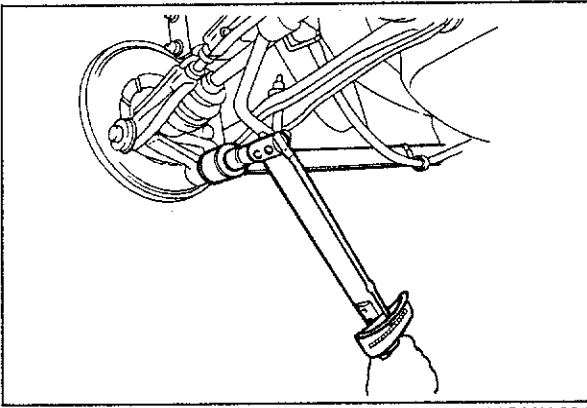

63G09X-394

4. Install the trailing link.

**Tightening torque:**

**93—117 N·m (9.5—11.9 m·kg, 69—86 ft·lb)**

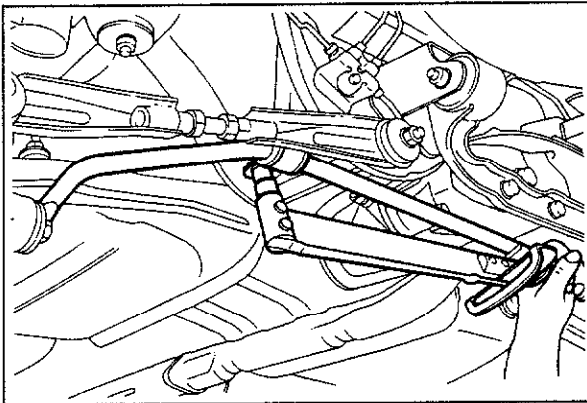

63G09X-395

5. Install the stabilizer.

**Tightening torque:**

**12—18 N·m (1.2—1.8 m·kg, 9—13 ft·lb)**

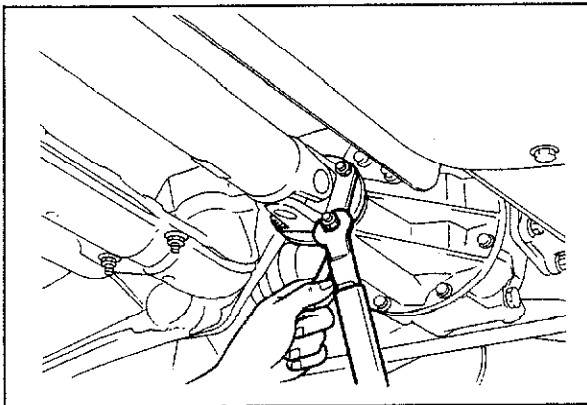

63G09X-396

6. Install the propeller shaft.

**Tightening torque:**

**27—30 N·m (2.8—3.1 m·kg, 20—22 ft·lb)**

7. Install the tires.

**Tightening torque:**

**88—118 N·m (9—12 m·kg, 65—87 ft·lb)**

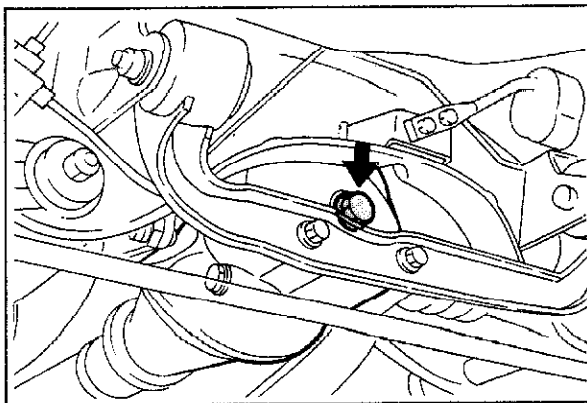

63G09X-397

8. Fill the differential with the correct grade and quantity of oil.

9. Tighten the oil fill plug.

**Tightening torque:**

**39—54 N·m (4.0—5.5 m·kg, 29—40 ft·lb)**

# 9 REAR DRIVESHAFT

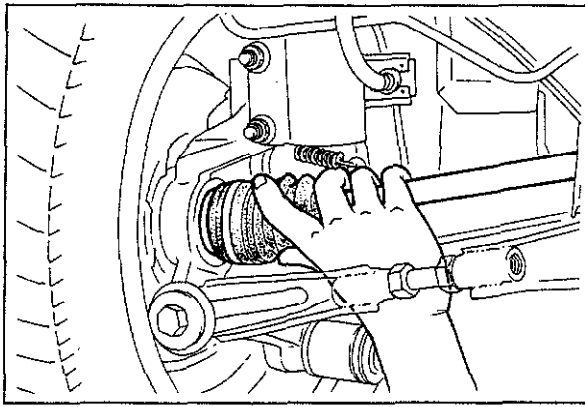

63G09X-398

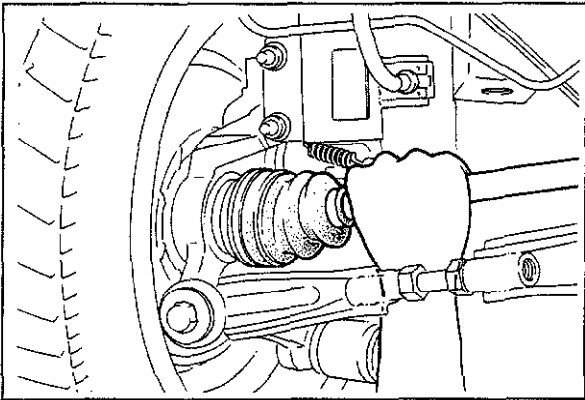

63G09X-399

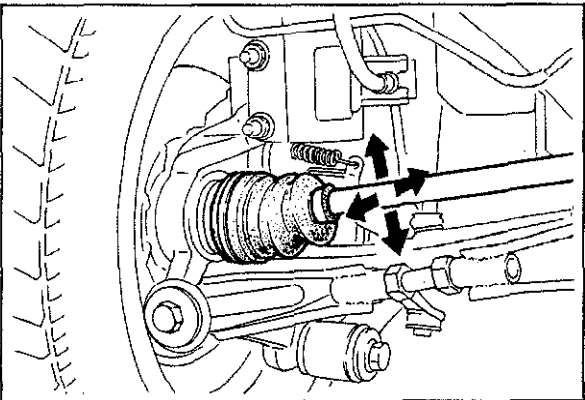

63G09X-400

## REAR DRIVESHAFT

### ON-VEHICLE CHECK

Check the following points, if a problem is found, replace the part.

1. Check the dust boot on the driveshaft for cracks, damage, leaking grease, or a loose boot band.
2. Check the driveshaft bearing for cracking, and wear of the splines.
3. Check the joint for wear by moving as shown in the figure.

## REMOVAL AND INSTALLATION

1. Jack up the rear of the vehicle and support it with safety stands.
2. Remove the parts in the sequence shown in the figure.
3. Install in the reverse order of removal.

63G09X-401

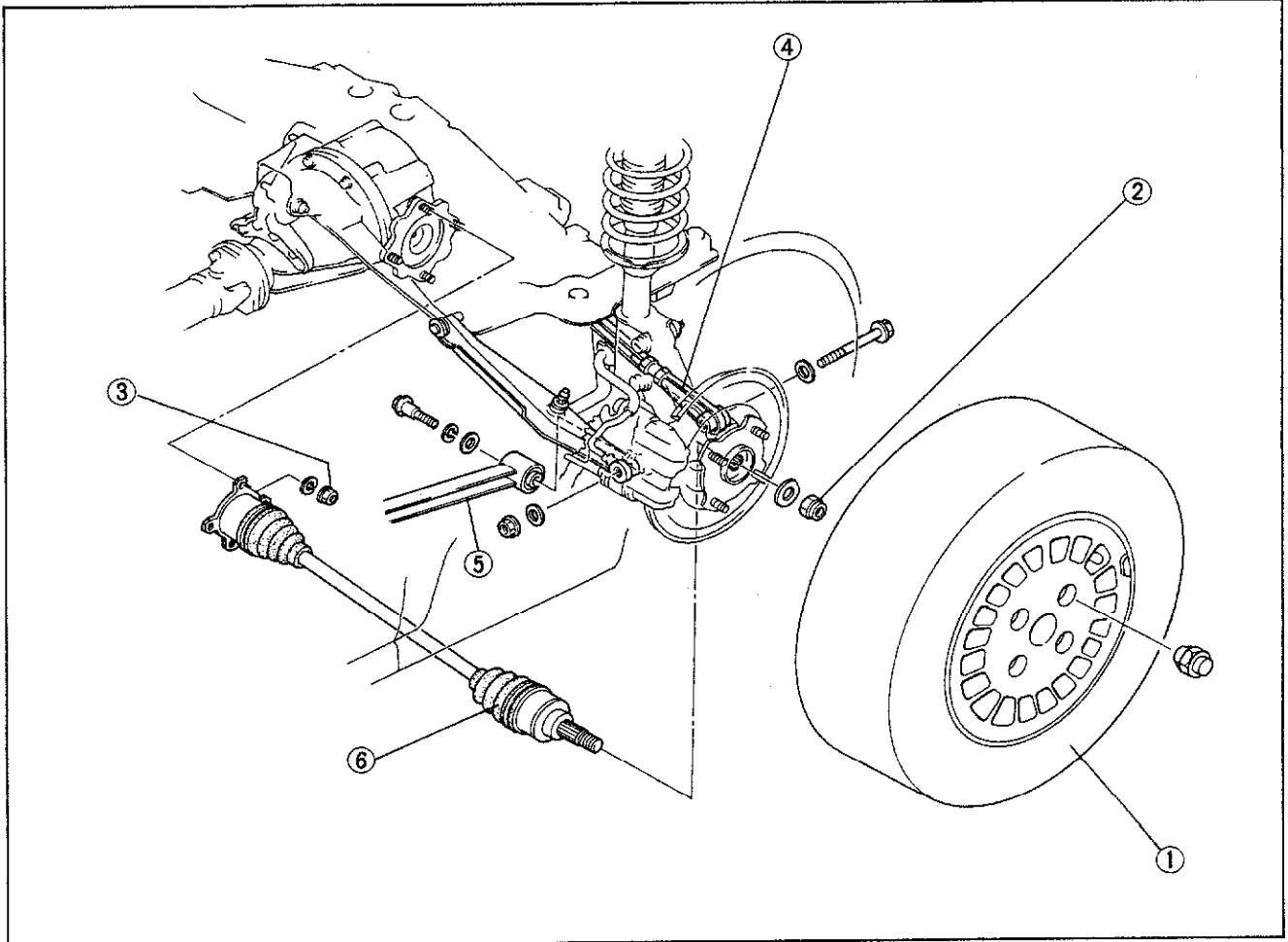

63G09X-402

1. Tire
2. Lock nut
3. Nut

4. Lateral link
5. Trailing link
6. Driveshaft

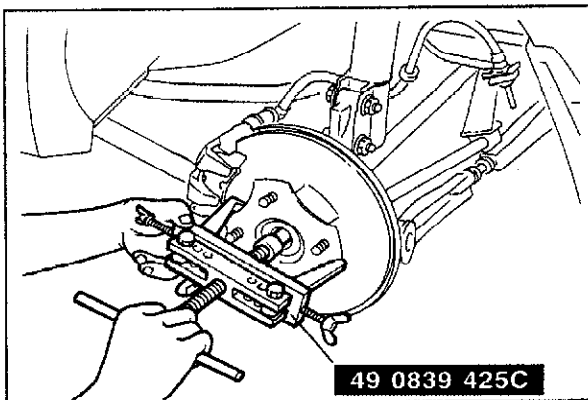

49 0839 425C

83U09X-058

### Wheel Hub

If the driveshaft is stuck to the wheel hub, use the **SST** to push the driveshaft out.

# 9 REAR DRIVESHAFT

## DISASSEMBLY AND ASSEMBLY

1. Disassemble in the sequence shown in the figure.
2. Assemble in the reverse order of removal.

### Caution

- a) Secure the joint in a vise with protective material (such as copper plates) on the vise jaws.
- b) Be careful that dust or other foreign material does not enter the joint while the work is being performed.
- c) Do not disassemble the wheel side ball joint.
- d) Do not wash the joint unless it is being disassembled.

63G09X-404

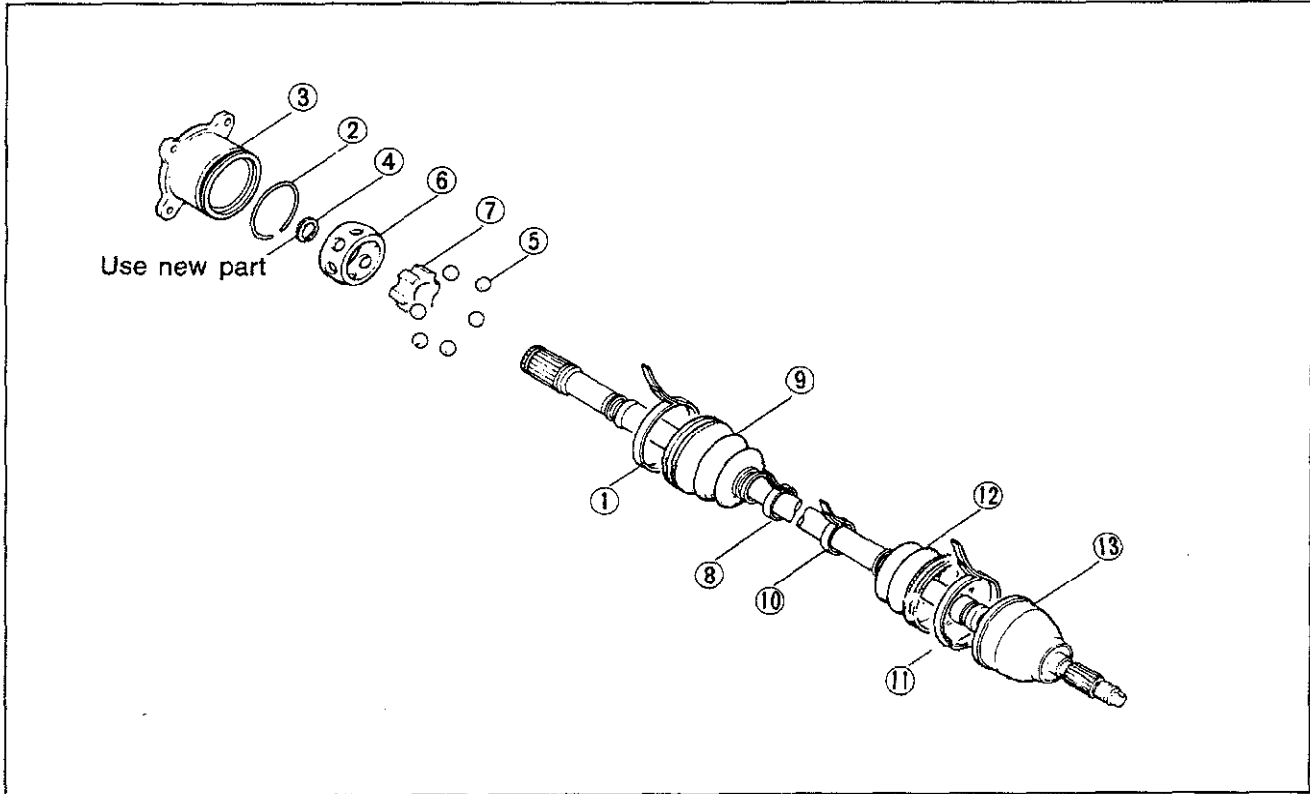

63G09X-405

- |               |               |                                   |
|---------------|---------------|-----------------------------------|
| 1. Boot band  | 6. Inner ring | 11. Boot band                     |
| 2. Clip       | 7. Cage       | 12. Boot                          |
| 3. Outer ring | 8. Boot band  | 13. Shaft and ball joint assembly |
| 4. Snap ring  | 9. Boot       |                                   |
| 5. Balls      | 10. Boot band |                                   |

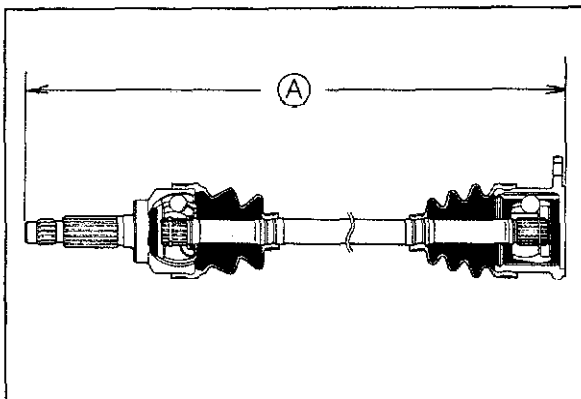

63G09X-406

**Standard length A:**  
**Right side: 651.3 mm (25.64 in)**  
**Left side: 681.3 mm (26.82 in)**

**Note**  
**The wheel side and differential side boots are different.**

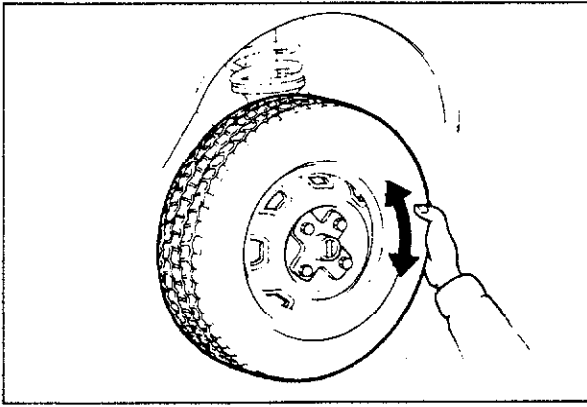

63G09X-407

## REAR AXLE

### ON-VEHICLE CHECK Wheel Bearing Play

1. Jack up the rear of the vehicle and support it with safety stands.
2. Check that there is no abnormal noise and that the tire rotates smoothly when rotated by hand.

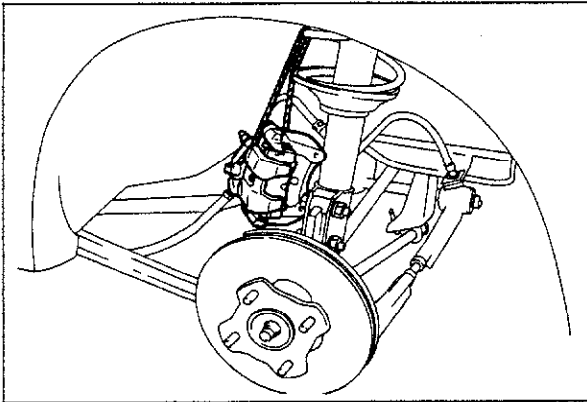

63G09X-408

3. Remove the caliper assembly, and support it from the shock absorber.

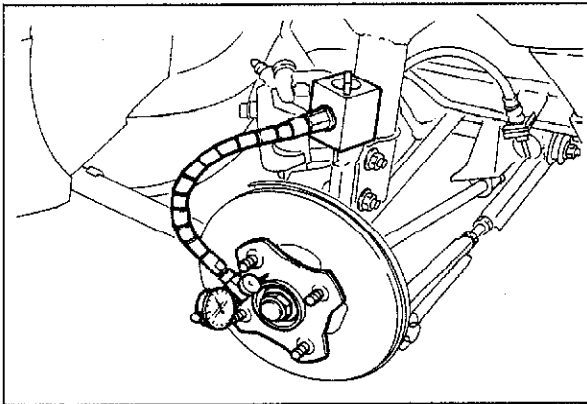

63G09X-409

4. Set a dial gauge against the axle flange. Then push and pull the axle hub by hand in the axial direction, and measure the end play of the wheel bearing.  
If the end play exceeds the specification, adjust the wheel bearing.

**End play: 0 mm (0 in).**

# 9 REAR AXLE

## REMOVAL AND INSTALLATION

1. Jack up the rear of the vehicle and support it with safety stands.
2. Remove the parts in the sequence shown in the figure.
3. Install in the reverse order of removal.

63G09X-410

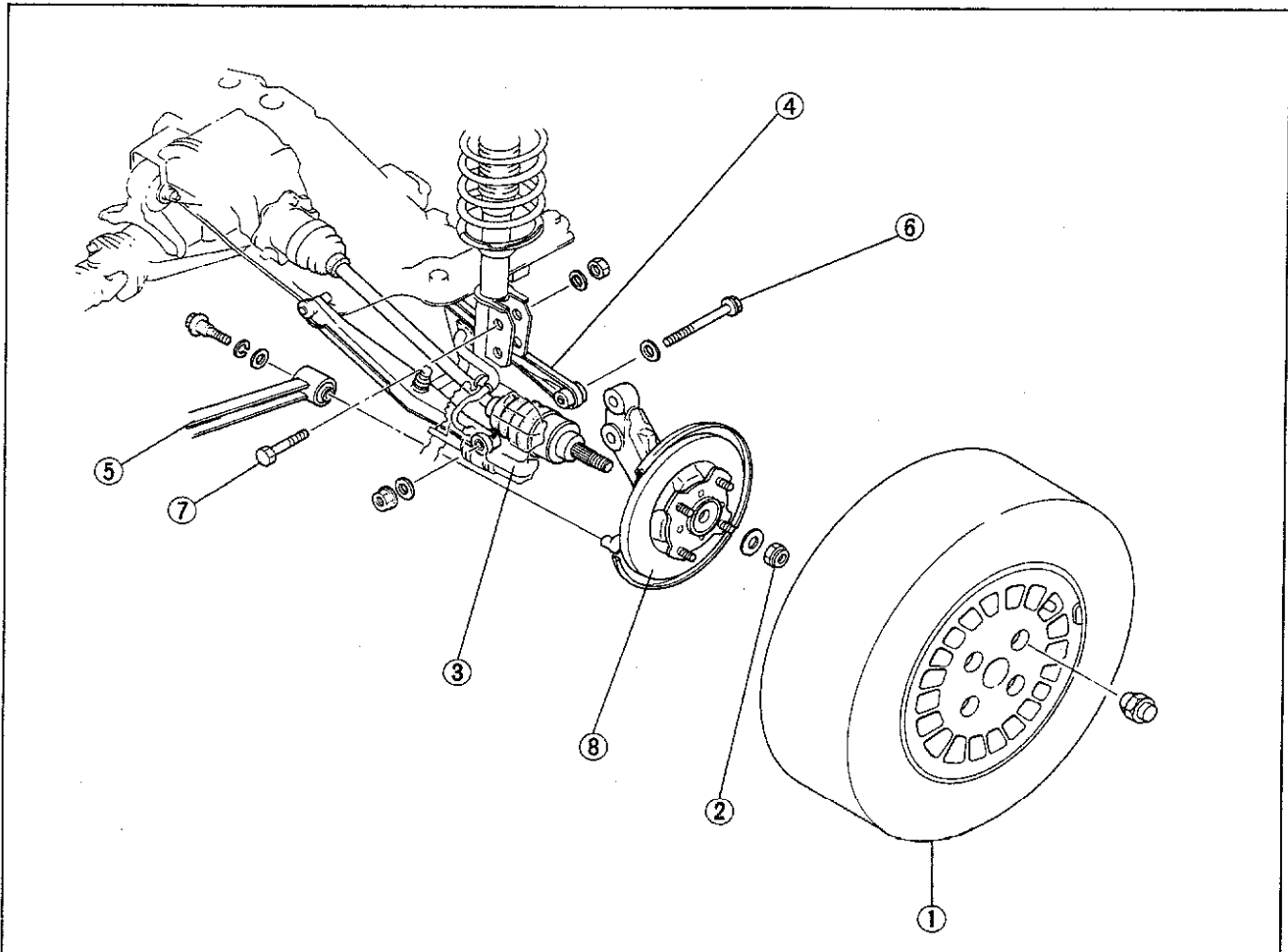

63G09X-411

- |                          |                             |
|--------------------------|-----------------------------|
| 1. Tire                  | 5. Trailing link            |
| 2. Lock nut              | 6. Bolt                     |
| 3. Disc caliper assembly | 7. Bolt                     |
| 4. Lateral link          | 8. Hub and knuckle assembly |

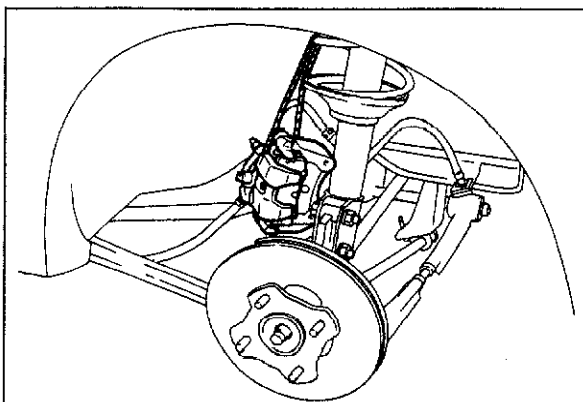

63G09X-412

### Removal Note

1. Remove the disc caliper assembly from the knuckle, and suspension it from the shock absorber.



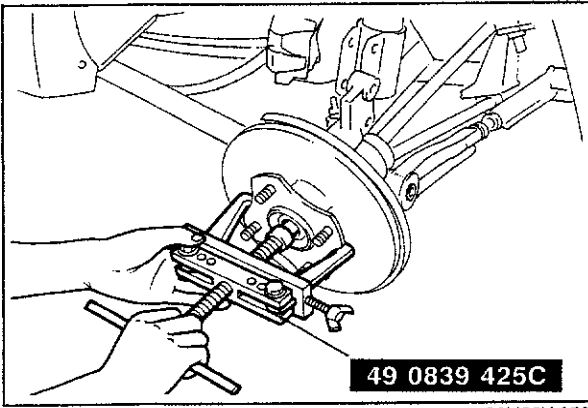

83U09X-059

- If the driveshaft is stuck to the wheel hub, use the **STT** to push the driveshaft out.

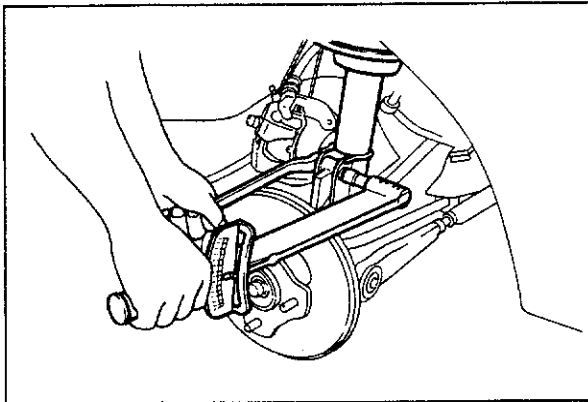

63G09X-414

### Installation Note

- Tighten the shock absorber through bolt.

#### Tightening torque:

**78—117 N·m (8.0—11.9 m·kg, 58—86 ft·lb)**

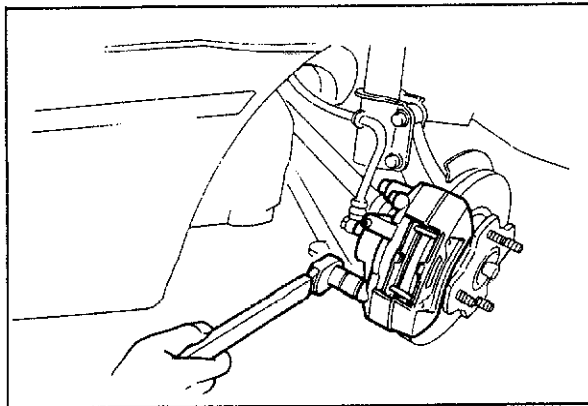

63G09X-415

- Tighten the disc caliper assembly.

#### Tightening torque:

**49—69 N·m (5.0—7.0 m·kg, 36—51 ft·lb)**

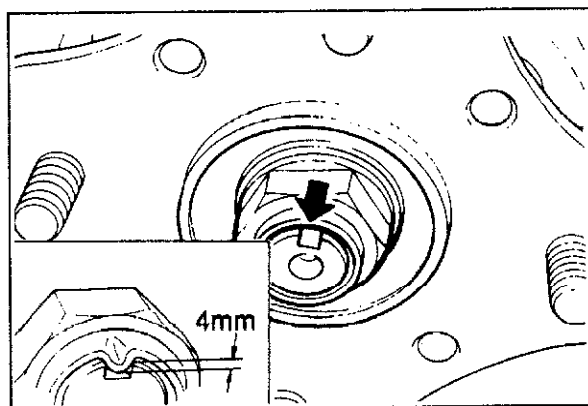

63G09X-416

- Tighten the lock nut, and stake the lock nut to the groove in the spindle.

#### Tightening torque:

**157—235 N·m**

**(16—24 m·kg, 116—174 ft·lb)**

# 9 REAR AXLE

## DISASSEMBLY

Disassemble in the sequence shown in the figure.

63G09X-417

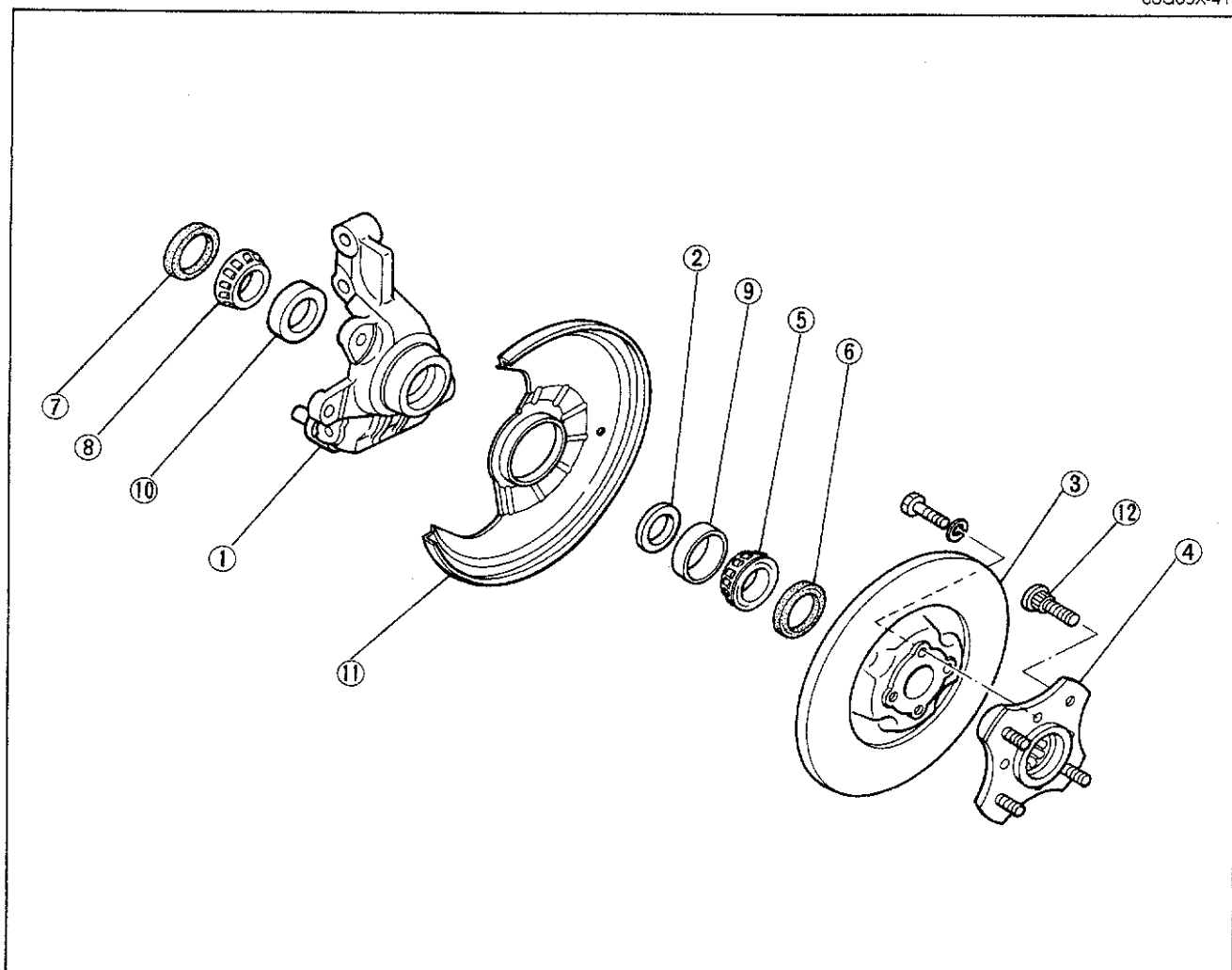

63G09X-418

- |                     |                                |
|---------------------|--------------------------------|
| 1. Knuckle          | 7. Oil seal (Inner)            |
| 2. Spacer           | 8. Bearing (Inner)             |
| 3. Disc plate       | 9. Bearing outer race (Outer)  |
| 4. Wheel hub        | 10. Bearing outer race (Inner) |
| 5. Bearing (Outer)  | 11. Dust cover                 |
| 6. Oil seal (Outer) | 12. Wheel lug bolt             |

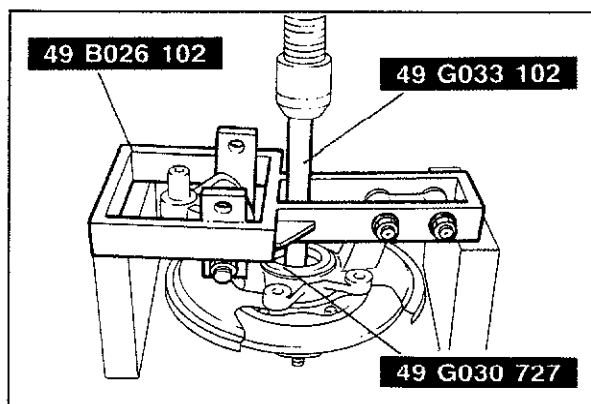

83U09X-060

### Knuckle

1. Remove the wheel hub and disc plate from the knuckle using the **SST** and a press.

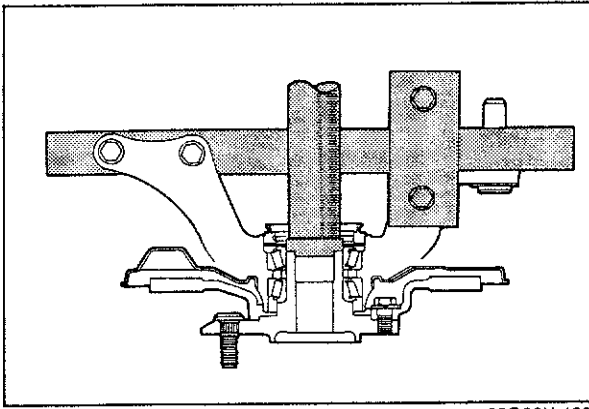

63G09X-420

**Note**

Support the wheel hub and disc plate by hand to prevent it from falling.

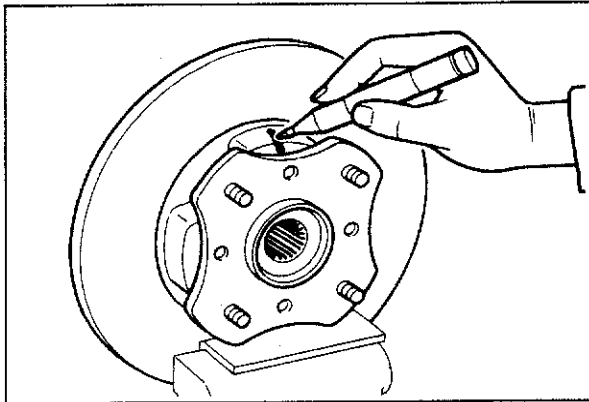

63G09X-421

**Wheel Hub**

Put mating marks on the disc plate and the wheel hub then remove the wheel hub.

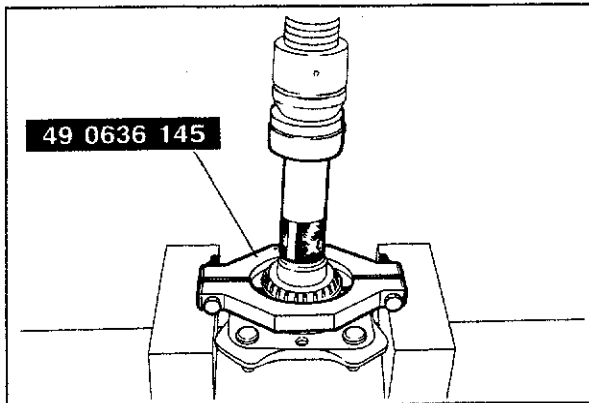

83U09X-061

**Bearing and Oil Seal (Outer)**

Set the SST between the oil seal and wheel hub, and remove the bearing and oil seal together.

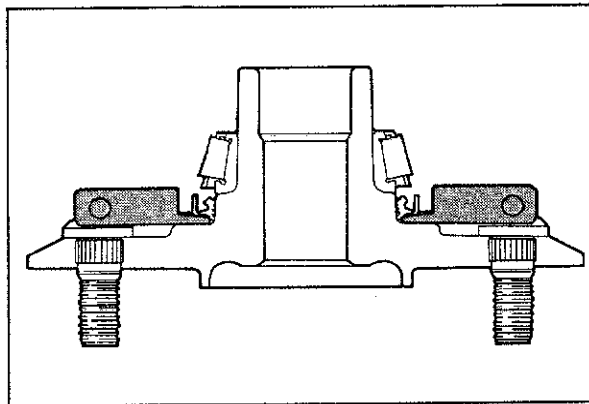

63G09X-423

**Note**

Support the wheel hub by hand to prevent it from falling.

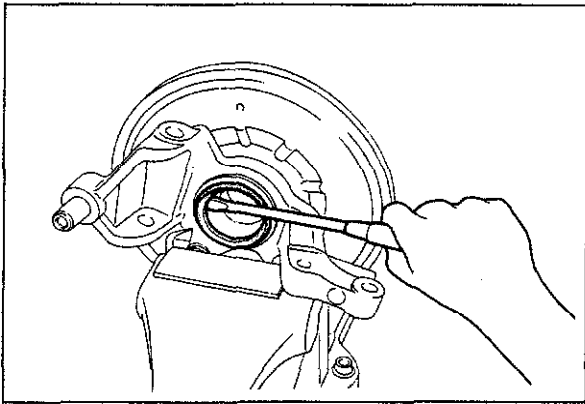

63G09X-424

### Oil Seal (Inner)

Remove the oil seal using a screwdriver.

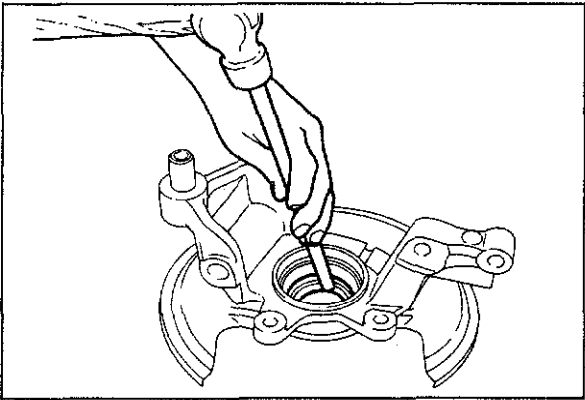

63G09X-425

### Bearing Outer Race (Inner and Outer)

Remove the bearing outer race by tapping the races alternately.

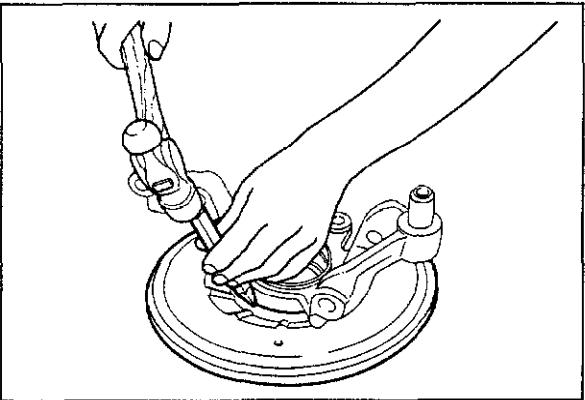

63G09X-426

### Dust Cover

Remove the dust cover.

### Note

Never remove the dust cover from the knuckle except when replacing it.

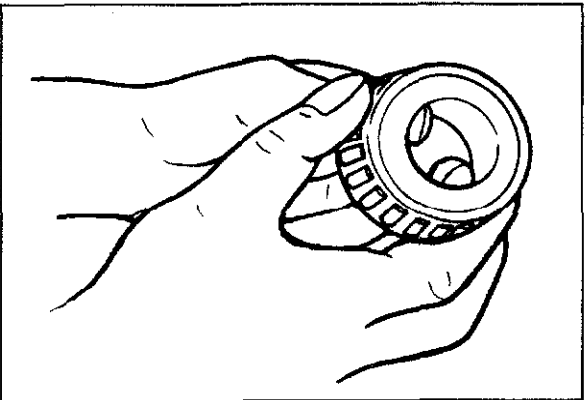

63G09X-427

### INSPECTION

Check the following points, if a problem is found, replace the part.

### Bearing

Check the bearing for wear, damage or binding.

### Caution

If replacement is necessary, replace the bearing and outer race as a set.

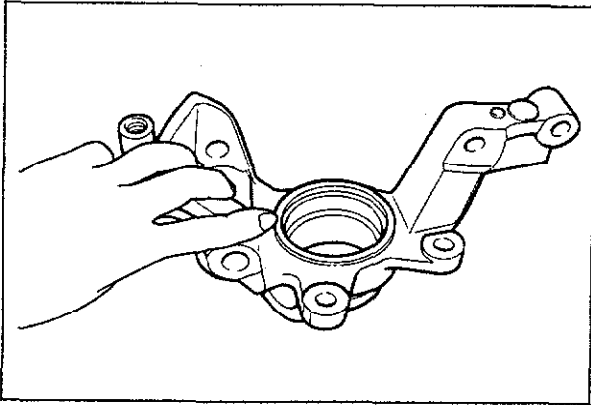

63G09X-428

**Knuckle**

Check the knuckle for cracking or damage.

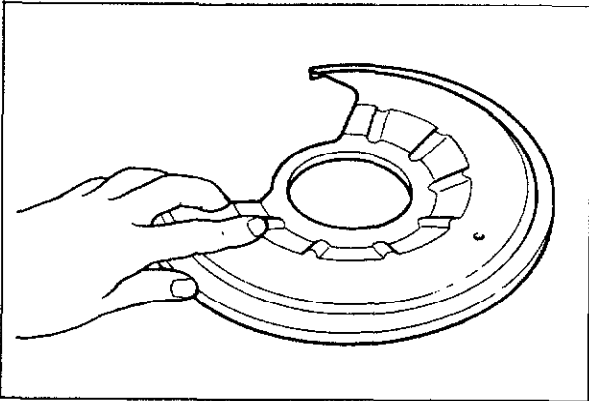

63G09X-429

**Dust Cover**

Check the dust cover for deformation or damage.

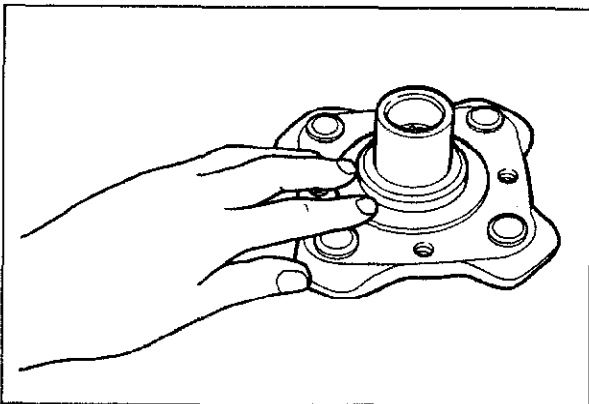

63G09X-430

**Wheel Hub**

Check the wheel hub for cracking or damage.

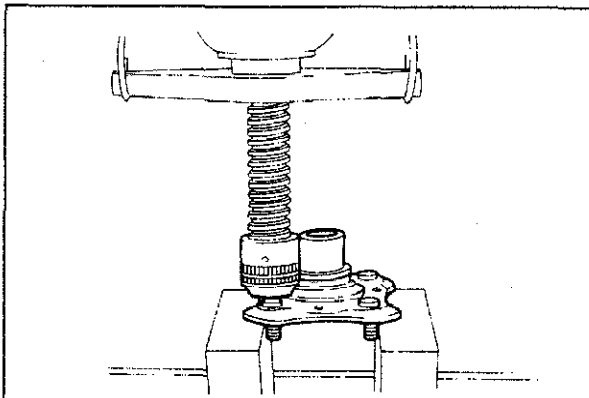

63G09X-431

**ASSEMBLY**

Assemble in the reverse order of removal.

**Wheel Lug Bolt**

Remove and replace the wheel lug bolt using press.

**Caution**

**Do not re-use the wheel lug bolts once they have been removed.**

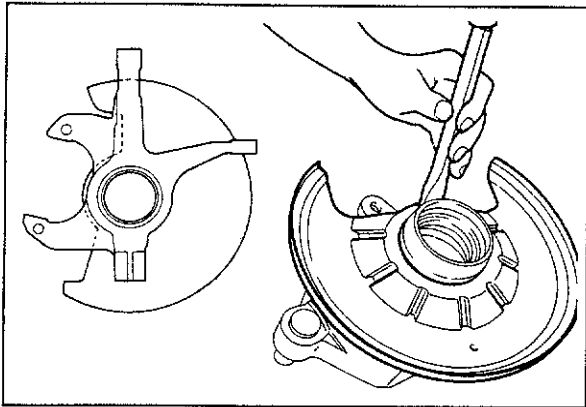

63G09X-432

### Dust Cover

Install the dust cover as shown in the figure.

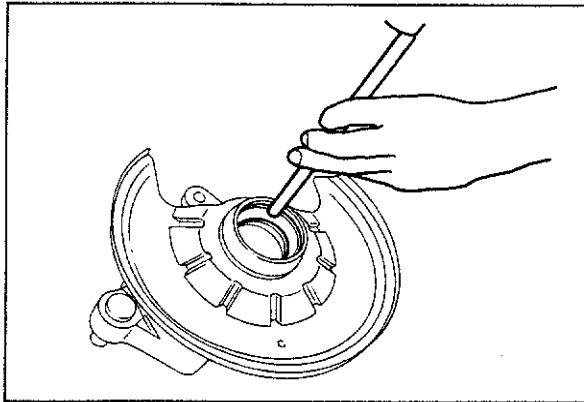

63G09X-433

### Bearing Outer Race (Inner and Outer)

Tap the bearing outer race with a brass drift and hammer.

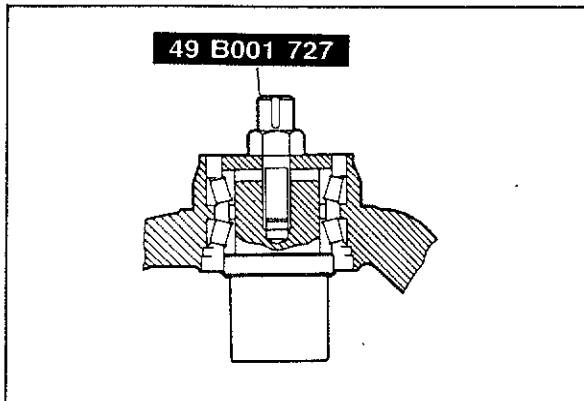

83U09X-062

### Bearing (Inner and Outer)

#### Adjustment of bearing preload

1. Install the inner bearing, spacer and outer bearing, and set the **SST** as shown in the figure.

#### Note

Use the same spacer which was removed at disassembly.

2. Measure the bearing preload with the spacer selector tightened to specified torque.

#### Tightening torque:

1.96 N·m (20 cm·kg, 17.4 in·lb)

#### Preload: 0.20—0.78 N·m

(2—8 cm·kg, 1.74—6.94 in·lb)

#### Balance scale:

2.26—8.63 N (230—880g, 0.51—1.94 lb)

#### Note

Hook the balance scale as shown.

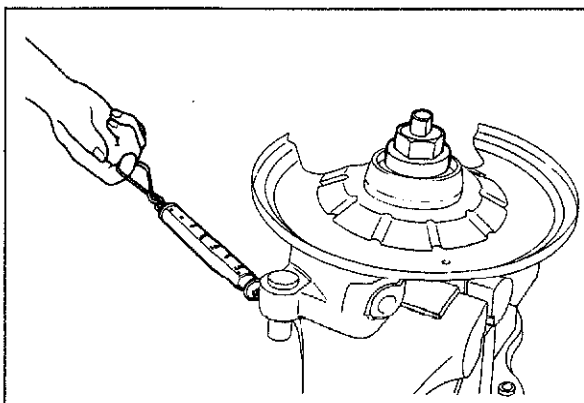

63G09X-435

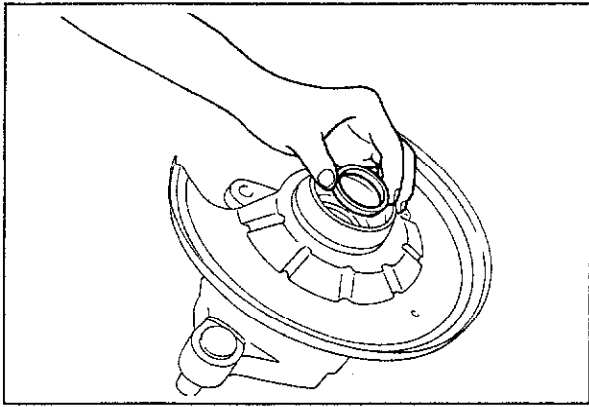

63G09X-436

Mark	Thickness mm (in)	Mark	Thickness mm (in)
1	6.29 (0.2476)	12	6.73 (0.2650)
2	6.33 (0.2492)	13	6.77 (0.2665)
3	6.37 (0.2508)	14	6.81 (0.2681)
4	6.41 (0.2524)	15	6.85 (0.2697)
5	6.45 (0.2539)	16	6.89 (0.2713)
6	6.49 (0.2555)	17	6.93 (0.2728)
7	6.53 (0.2571)	18	6.97 (0.2744)
8	6.57 (0.2587)	19	7.01 (0.2760)
9	6.61 (0.2602)	20	7.05 (0.2776)
10	6.65 (0.2618)	21	7.09 (0.2791)
11	6.69 (0.2634)		

63G09X-437

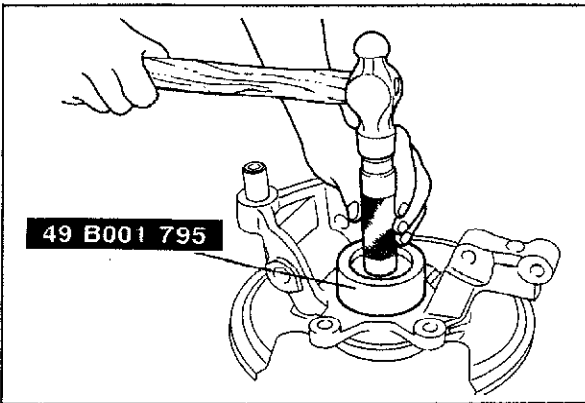

83U09X-063

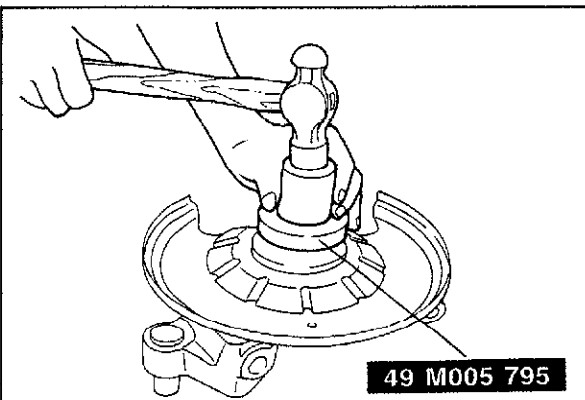

83U09X-064

- If not within specification, adjust the bearing preload by selection of a spacer.

**Note**

a) If bearing preload is excessive, use a thicker spacer.

If bearing preload is less than specified, use a thin spacer.

b) If the spacer is thinner changed by one (1) rank, the bearing preload is changed by 0.20—0.39 N·m (2—4 cm·kg, 1.74—3.47 in·lb)

- Install the bearing (inner).
- Install the oil seal (inner) using the SST.

**Note**

Apply a thin coat of grease (lithium base, NLGI No. 2) to the oil seal lip.

- Install the spacer.

**Note**

Install the spacer selected for the bearing preload adjustment.

- Install the bearing (outer).
- Install the oil seal (outer) using the SST.

**Note**

Apply a thin coat of grease (lithium base, NLGI No. 2) to the oil seal lip.

## 9 REAR AXLE

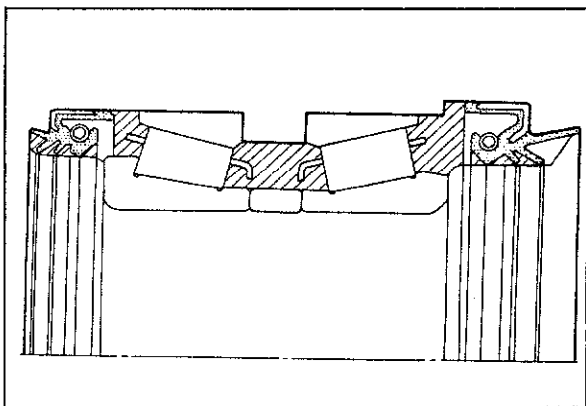

63G09X-440

9. Apply grease (lithium base, NLGI No. 2) to the area indicated by the oblique lines.

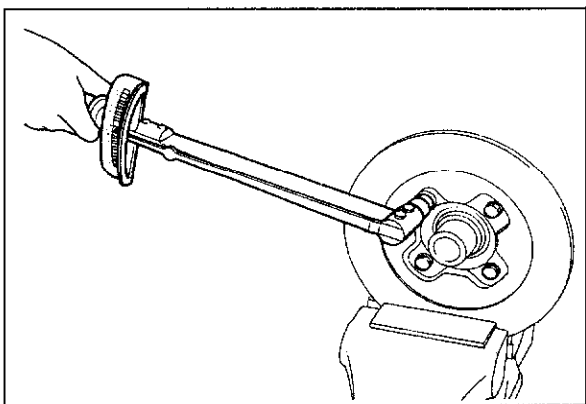

63G09X-441

### Wheel Hub

Align the mating marks of the wheel hub and the disc plates and tighten.

### Tightening torque:

**44—54 N·m (4.5—5.5 m·kg, 33—40 ft·lb)**

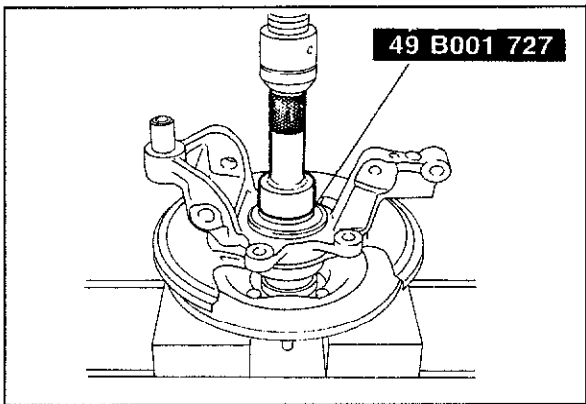

83U09X-065

### Knuckle

Install the knuckle using the **SST**.

**Press force: 3,000 kg (3 tons)**



# STEERING SYSTEM

<b>OUTLINE</b> .....	10— 2
STRUCTURAL VIEW .....	10— 2
SPECIFICATIONS .....	10— 4
<b>TROUBLESHOOTING GUIDE</b> .....	10— 5
MANUAL STEERING .....	10— 5
POWER STEERING .....	10— 6
<b>ON-VEHICLE MAINTENANCE</b> .....	10— 7
STEERING WHEEL PLAY .....	10— 7
LOOSENESS OR PLAY OF STEERING WHEEL.....	10— 7
STEERING WHEEL EFFORT .....	10— 7
POWER STEERING FLUID LEVEL .....	10— 8
LOOSE OR DAMAGED OIL PUMP BELT ..	10— 8
LINKAGE OF POWER STEERING FLUID...	10— 9
<b>INSPECTION AND ADJUSTMENT</b> .....	10—10
BLEEDING OF POWER STEERING SYSTEM	10—10
POWER STEERING PRESSURE.....	10—11
FRONT WHEEL ALIGNMENT.....	10—12
<b>TIE-ROD END BOOT</b> .....	10—15
REMOVAL AND INSTALLATION .....	10—15
<b>STEERING WHEEL AND COLUMN</b> .....	10—17
REMOVAL AND INSTALLATION .....	10—17
INSPECTION .....	10—19
<b>STEERING GEAR AND LINKAGE</b> .....	10—21
REMOVAL AND INSTALLATION (2WD).....	10—21
REMOVAL AND INSTALLATION (4WD).....	10—23
DISASSEMBLY (MANUAL STEERING, CONSTANT GEAR RATIO TYPE).....	10—27
INSPECTION .....	10—31
ASSEMBLY .....	10—31
DISASSEMBLY (MANUAL STEERING, VARIABLE GEAR RATIO TYPE) .....	10—37
INSPECTION .....	10—40
ASSEMBLY .....	10—41
DISASSEMBLY (POWER STEERING) .....	10—47
INSPECTION .....	10—52
ASSEMBLY .....	10—53
<b>OIL PUMP</b> .....	10—59
REMOVAL AND INSTALLATION .....	10—59
DISASSEMBLY AND ASSEMBLY .....	10—60

## OUTLINE

### STRUCTURAL VIEW

#### Manual Steering

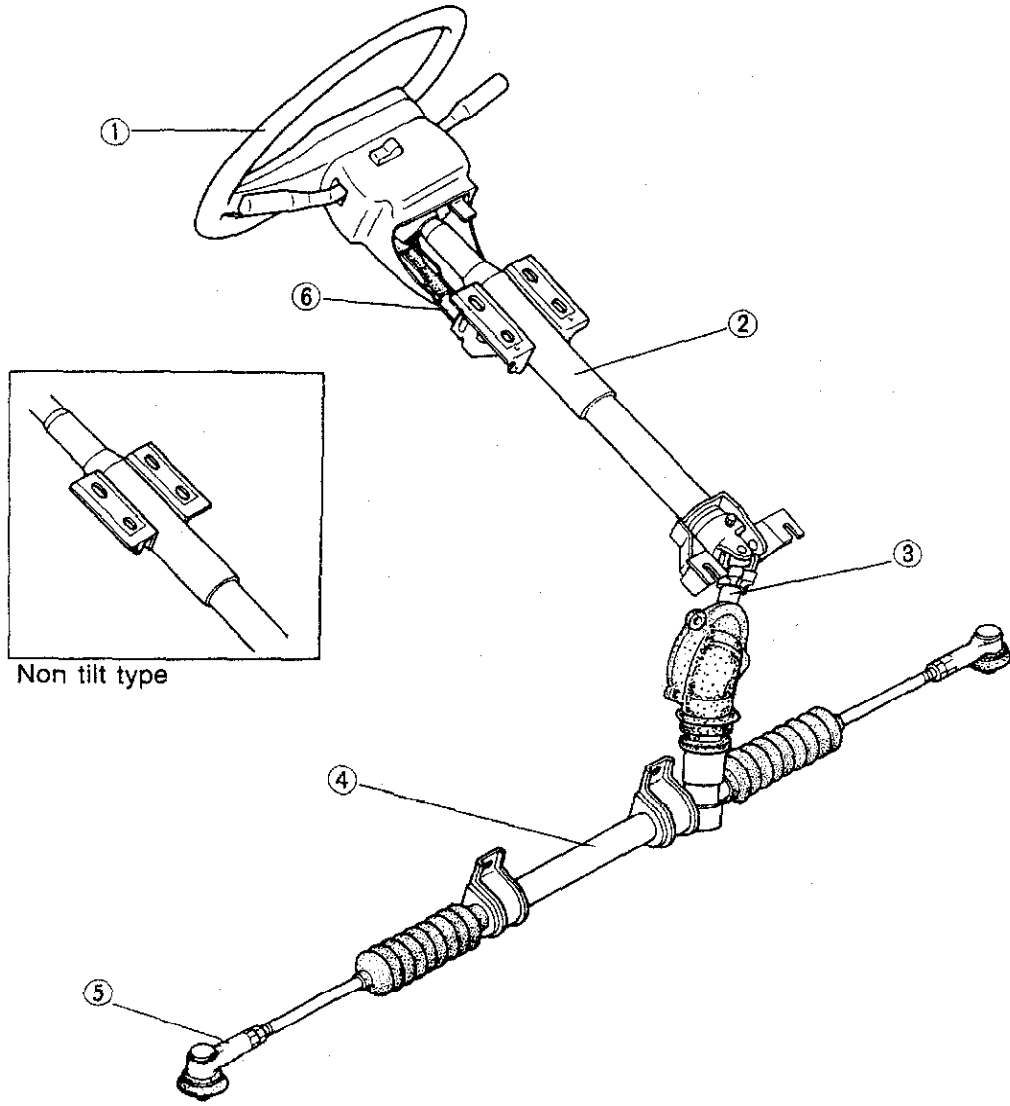

63U10X-002

- 1. Steering wheel
- 2. Steering shaft
- 3. Intermediate shaft
- 4. Steering gear
- 5. Tie-rod end
- 6. Tilt steering lock lever

Power Steering

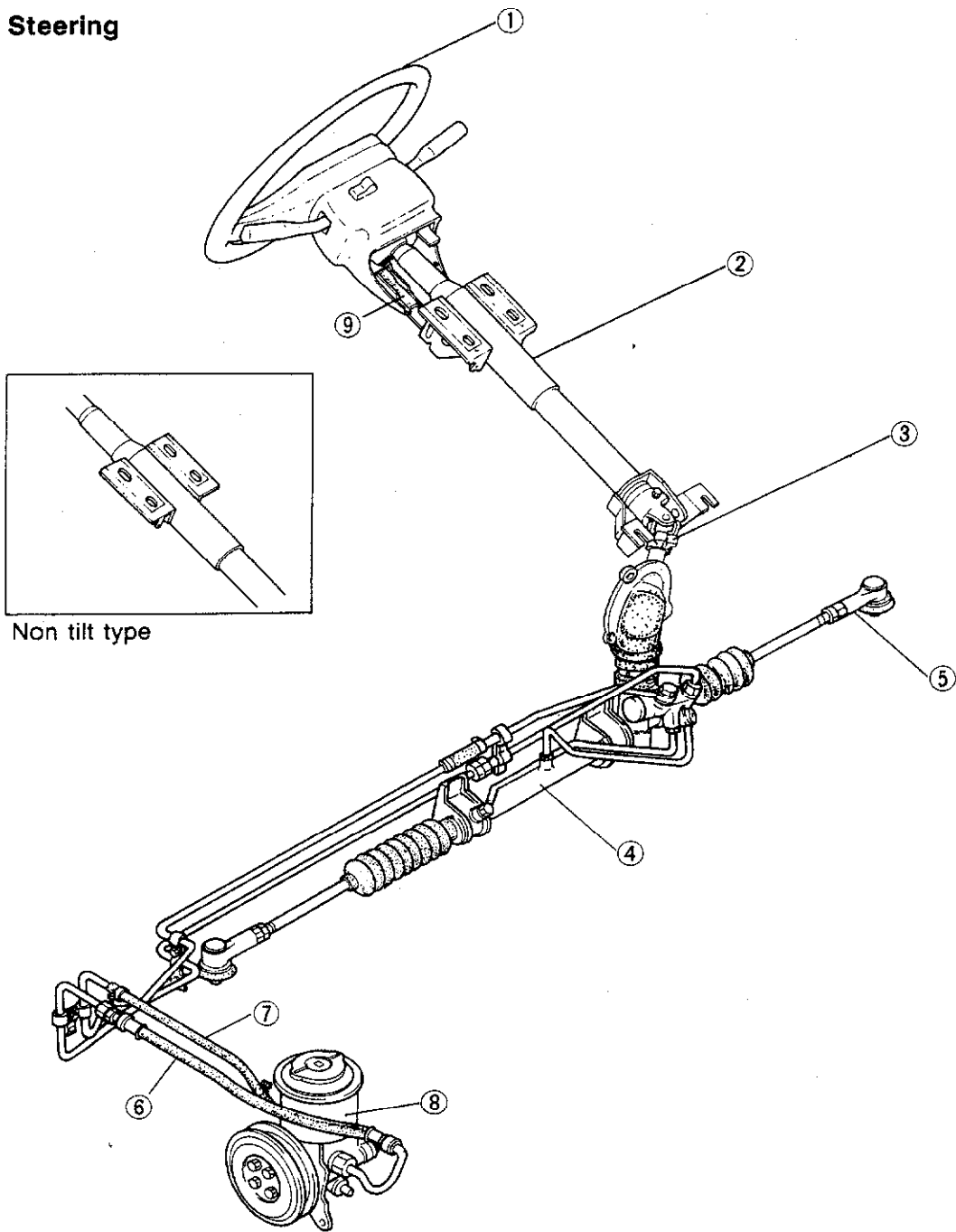

63U10X-003

- 1. Steering wheel
- 2. Steering shaft
- 3. Intermediate shaft

- 4. Steering gear
- 5. Tie-rod end
- 6. Pressure hose

- 7. Return hose
- 8. Oil pump
- 9. Tilt steering lock lever

# SPECIFICATIONS

Item		Model		2WD		4WD
		M/S	P/S	P/S		
Steering wheel	Outer diameter	mm (in)		380 (14.5)		
	Lock-to-lock	3.6 (CGR) 4.2 (VGR)	3.2	2.9		
Steering shaft and joint	Type	Collapsible				
	Joint type	Cross joint				
	Tilt stroke	mm (in)		18.6 (0.73)		
Steering gear	Type	Rack and pinion				
	Gear ratio	(∞) (infinite)				
	Rack stroke	mm (in)		136 (5.35)	140 (5.51)	
Oil	Capacity	liter (US qt, Imp qt)		—	0.6 (0.63, 0.53)	0.6 (0.63, 0.53)
	Type	—		ATF DEXRON II or M2C33-F		
Wheel alignment	Maximum steering angle	Inner	40°00' ± 2°		39°00' ± 2°	
		Outer	33°00' ± 2°		31°00' ± 2°	
	Toe-in	mm (in)		2 ± 3 (0.08 ± 0.12)		
	Camber angle			0°50' ± 30'	1°00' ± 30'	
	Caster angle			1°35' ± 45'	1°45' ± 45'	
	King-pin angle			12°20'	12°05'	
	Caster trail	mm (in)		10.0 (0.39)	8.3 (0.33)	

CGR : Constant Gear Ratio  
VGR : Variable Gear Ratio  
83U10X-002

## TROUBLESHOOTING GUIDE

### MANUAL STEERING

Problem	Possible Cause	Remedy	Page
<b>Steering "heavy" (Vehicle jacked up, both wheels off ground)</b>	Poor lubrication, presence of foreign material, or abnormal wear of ball joint	Lubricate or replace	10—15
	Stuck or damaged ball joint	Replace	10—15
	Improperly adjusted steering pinion preload	Adjust	10—35, 43
	Damaged steering gear	Replace	10—21
	Worn or damaged rubber mount	Replace	10—21
	No grease in steering gear	Lubricate	—
	Malfunction of steering-shaft joint	Replace	10—17
<b>Steering wheel pulls to one side</b>	Damaged steering linkage	Replace	10—21
	Incorrect adjustment of front wheel bearing preload	Adjust	—
	Fatigued front springs	Replace	—
	Damaged knuckle arm	Replace	—
	Incorrect wheel alignment (toe-in)	Adjust	10—12
	Incorrect tire air pressure	Adjust	—
	Abnormal tire wear	Replace	—
	Worn or damaged stabilizer and/or lower arm bushing	Replace	—
Deformed or loose lower arm	Replace or tighten	—	
<b>Unstable driving</b>	Damaged steering linkage	Replace	10—21
	Worn or damaged joint of steering system	Replace	10—17
	Improperly adjusted steering pinion preload	Adjust	10—35, 43
	Incorrect adjustment of front wheel bearing preload	Adjust	—
	Fatigued front spring	Replace	—
	Malfunction of shock absorber	Replace	—
	Incorrect wheel alignment (toe-in)	Adjust	10—12
	Incorrect tire pressure	Adjust	—
	Wheels are deformed or out of balance	Repair or replace	—
Worn or damaged stabilizer and/or lower arm bushing	Repair	—	
<b>Steering wheel vibrates</b>	Incorrect adjustment of wheel bearing preload or worn wheel bearing	Adjust or replace	10—35, 43
	Damaged steering linkage	Replace	10—21
	Worn or damaged joint of steering system	Replace	10—17
	Improperly adjusted steering pinion preload	Adjust	10—35, 43
	Incorrect wheel alignment (toe-in)	Adjust	10—12
	Incorrect tire air pressure	Adjust	—
	Unevenly worn tires	Replacc	—
	Depth of tire tread different between left and right tires	Replace	—
	Wheels deformed or out of balance	Repair or replace	—
	Malfunctioning or loose shock absorbers	Replace or tighten	—
	Worn or damaged rubber mount	Replace	10—21
	Worn or damaged stabilizer and/or lower arm bushing	Replace	—
<b>Excessive steering wheel play</b>	Worn rack and pinion gear	Replace	10—27, 37
	Worn or damaged joint of steering system	Replace	10—17
	Incorrect adjustment of front wheel bearing preload	Adjust	—
	Worn or damaged lower-arm bushing	Replace	—
<b>Abnormal noise from steering system</b>	Loose or worn steering linkage	Tighten or replace	10—21
	Worn joint of steering system	Replace	10—17

83U10X-003

# 10 TROUBLESHOOTING GUIDE

## POWER STEERING

Problem	Possible Cause	Remedy	Page
<b>Steering wheel movement is "heavy"</b>	Loose or damaged belt	Adjust or replace	10—8
	Low fluid level, or air in fluid	Supply fluid, or bleed air	10—10
	Crimped pipe or hose, or twisted hose	Replace	—
	Insufficient tire pressure	Adjust	—
	Improperly adjusted wheel alignment	Adjust	10—12
	Linkage ball-joint does not operate smoothly	Repair or replace	10—21, 23
	Steering shaft is contacting something	Repair or replace	10—17
<b>Poor steering wheel return</b>	Incorrect tire pressure	Adjust	—
	Improperly adjusted wheel alignment	Adjust	10—12
	Linkage ball-joint does not operate smoothly	Repair or replace	10—15
	Steering shaft is over tight or restricted or bent	Replace	—
<b>Required steering effort is uneven</b>	Loose belt	Adjust	10—8
	Steering shaft is restricted; loose installation bolt(s)	Repair or tighten	10—17
	Steering linkage does not operate smoothly	Repair or replace	10—21, 23
	Malfunction of steering gear	Replace	10—21, 23
<b>Steering wheel pulls to one side</b>	Incorrect tire pressure	Adjust	—
	Improper preload adjustment, or wear of wheel bearing	Adjust or replace	—
	Improperly adjusted wheel alignment	Adjust	10—12
	Malfunction of steering gear	Replace	10—21, 23
<b>Fluid leakage</b>	Problem at hose coupling	Repair or replace	—
	Damaged or clogged hose	Replace	—
	Damaged oil tank	Replace	10—60
	Overflow	Bleed air, or adjust fluid level	10—10
	Malfunction of oil pump	Replace	10—59
	Malfunction of gear box	Replace	10—21, 23
<b>Abnormal noise</b>	Loose oil pump	Tighten	10—59
	Loose steering gear	Tighten	10—21, 23
	Loose oil pump bracket	Tighten	10—59
	Loose oil pump pulley bolt	Tighten	10—59
	Belt either loose or too tight	Adjust	10—8
	Air intake	Bleed air	10—10
	Malfunction inside steering gear	Replace	10—21, 23
	Malfunction of oil pump	Replace	10—59
	Obstruction near steering column or pressure hose	Repair or replace	—
	Play or looseness of steering linkage	Tighten, adjust, or replace	10—21, 23

83U10X-004

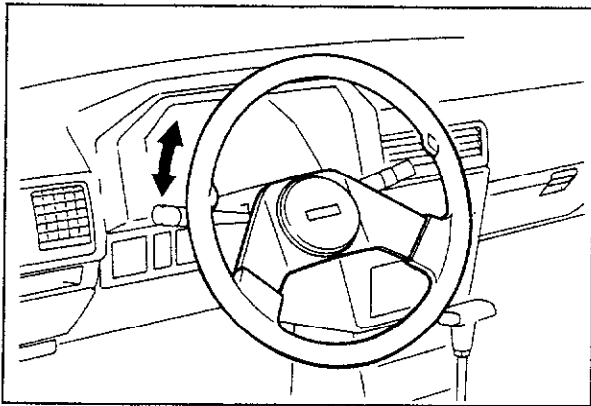

63U10X-007

## ON-VEHICLE MAINTENANCE

### STEERING WHEEL PLAY

With the wheels in the straight-ahead position, gently turn the steering wheel to the left and right and check if the play is within the standard range.

**Play: 0—30 mm (0—1.18 in)**

#### Note

**If the play exceeds the standard range, either the steering joints are worn or the backlash of the steering gear is excessive.**

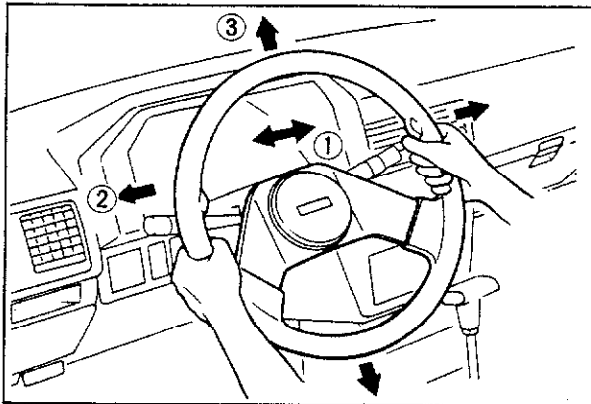

5BU10X-612

### LOOSENESS OR PLAY OF STEERING WHEEL

Move the steering wheel in the directions ①, ② and ③ to check for column bearing wear, steering-shaft joint play, steering wheel looseness, or column looseness.

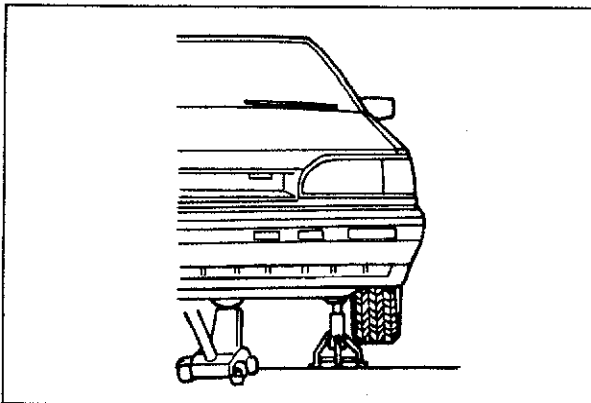

63U10X-008

### STEERING WHEEL EFFORT

#### Manual Steering

1. Jack up the vehicle. Move the steering wheel to put the wheels in the straight-ahead position.
2. Measure the steering wheel effort by connecting a pull scale to the outer circumference of the steering wheel.

#### Steering wheel effort:

**5—20 N (0.5—2.0 kg, 1—5 lb)**

**[during one turn of the steering wheel]**

#### Note

**Measure after turning the steering wheel to the left and right 5 times or more.**

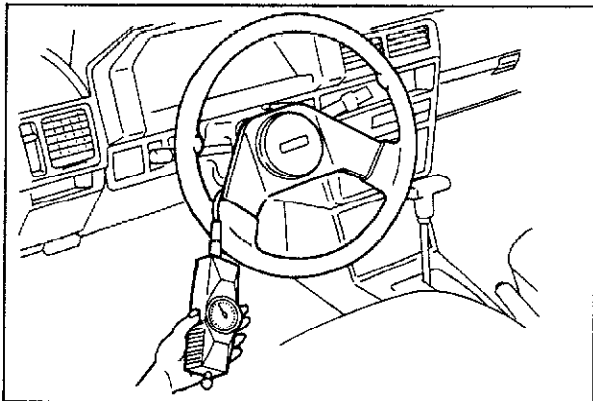

63U10X-009

3. If the measured value exceeds the standard range, check the following points; rotation-starting torque of the pinion, rotation torque of each ball-joint, and seizure of each joint.

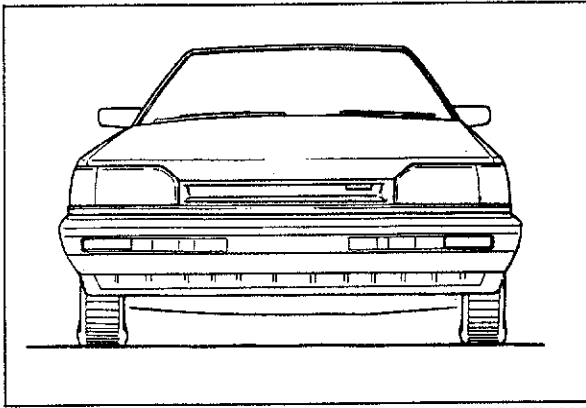

83U10X-005

## Power Steering

Check in the following order:

1. With the vehicle on a hard level surface, move the steering wheel to put the wheels in the straight-ahead position.
2. Start the engine and warm the power steering fluid to **50—60°C (122—140°F)**.

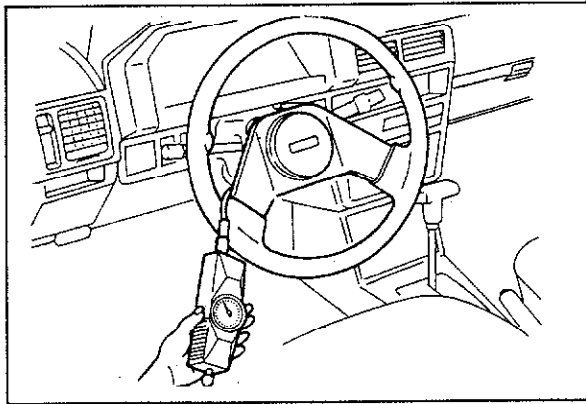

78U10X-010

3. Attach a pull scale to the outer circumference of the steering wheel. Then, starting with the wheels in the straight-ahead position, check the steering effort required to turn the steering wheel to the left and to the right.

**Steering wheel effort: 40 N (4.1 kg, 9 lb) or less [during one turn of the steering wheel]**

4. If measured value exceeds standard value range, check the following: fluid level, air in system, fluid leakage at hose or connections, function of oil pump and gear box, and tire pressure.

## POWER STEERING FLUID LEVEL

Check the power steering fluid level, and add fluid to the specified level if necessary.

### Caution

**Use only specified power steering fluid.**

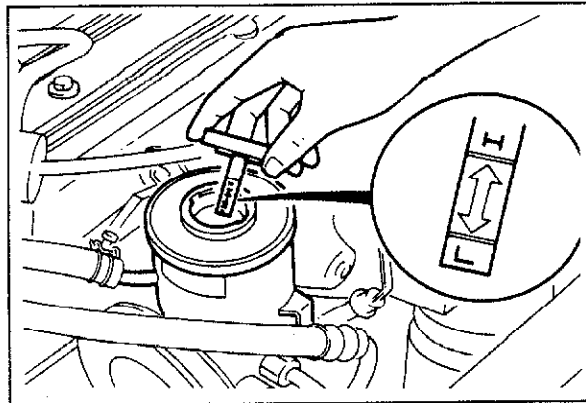

78U10X-013

## LOOSE OR DAMAGED OIL PUMP BELT Inspection

Check the oil pump belt for looseness or damage. To check the oil pump belt tension, apply moderate pressure 98 N (10 kg, 22 lb) midway between the pulleys.

### Deflection:

**New belt 8—9 mm (0.31—0.35 in)**

**Used belt 9—10 mm (0.35—0.39 in)**

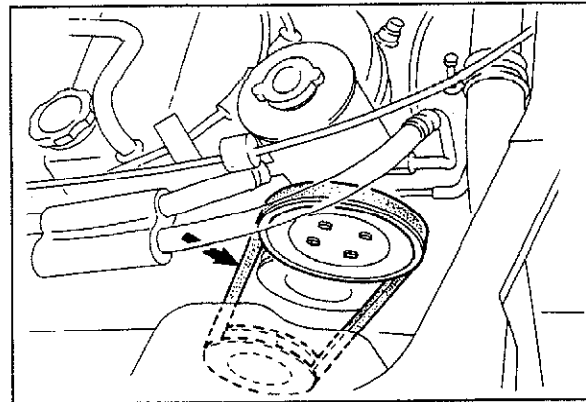

83U10X-006



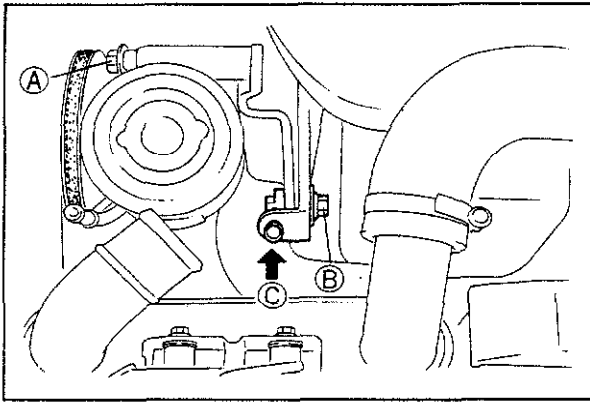

83U10X-007

### Adjustment

1. Loosen bolt (A).
2. Loosen nut (B).
3. Turn adjusting bolt (C) and adjust the belt tension.
4. After adjustment, tighten bolt (A) and nut (B).

### Bolt (A) tightening torque:

36—54 N·m  
(3.7—5.5 m·kg, 27—40 ft·lb)

### Nut (B) tightening torque:

31—46 N·m  
(3.2—4.7 m·kg, 23—34 ft·lb)

### LEAKAGE OF POWER STEERING FLUID

Check for fluid leakage in the places shown by arrows below.

#### Note

Start the engine, and check for fluid leakage after turning the steering wheel completely to the left and right to apply fluid pressure. Do not, however, keep the steering wheel in the fully turned position for more than 15 seconds.

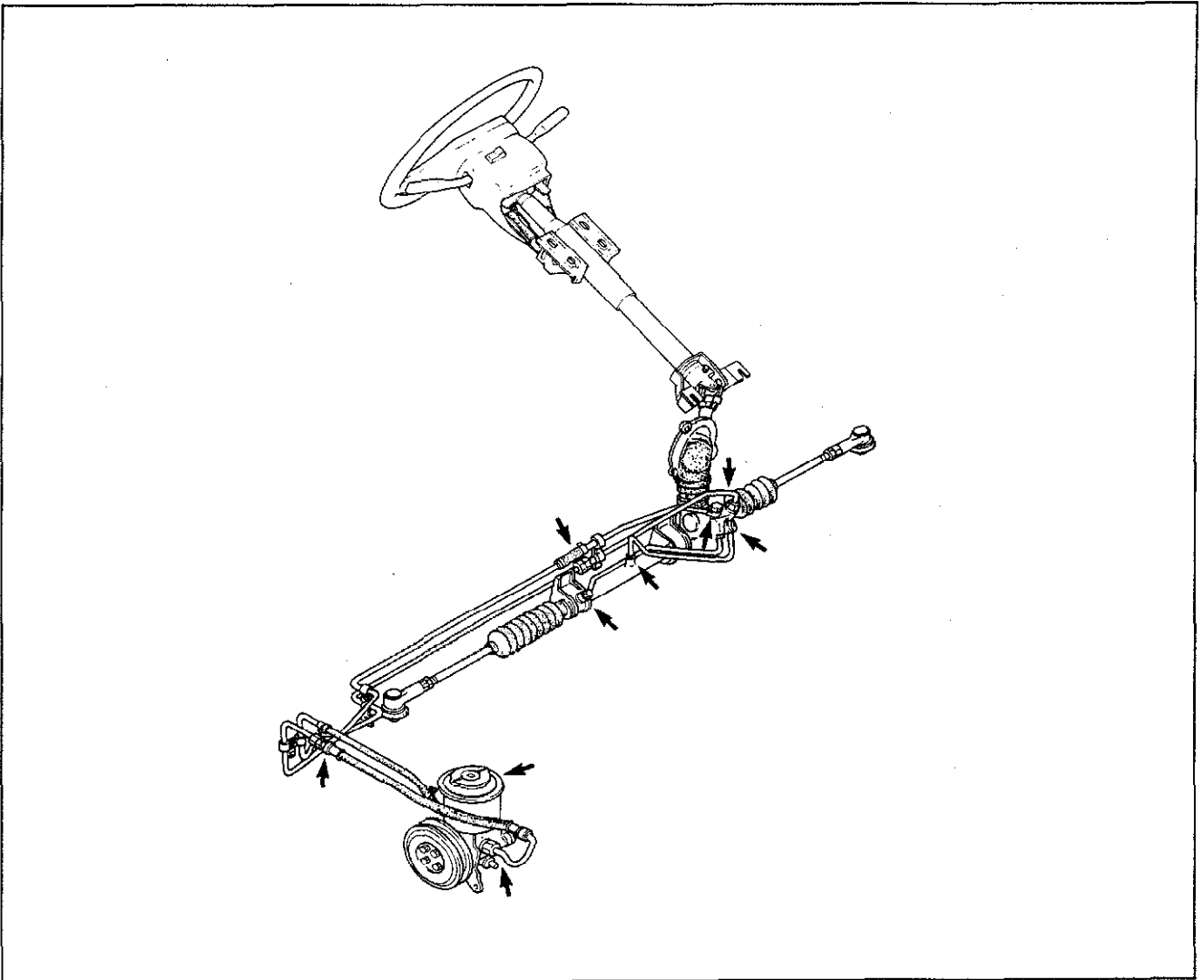

7BU10X-017

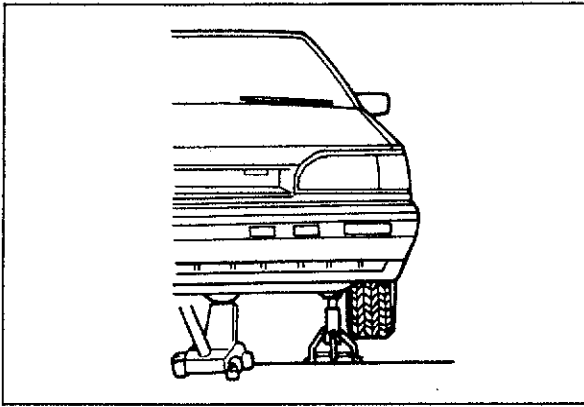

63U10X-014

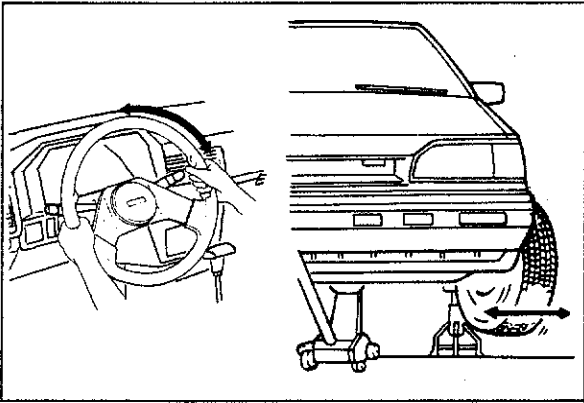

63U10X-015

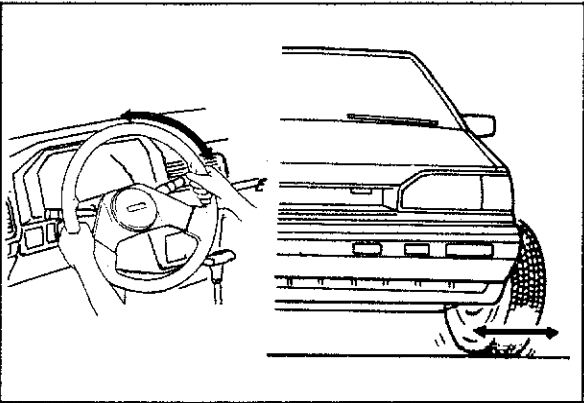

7BU10X-021

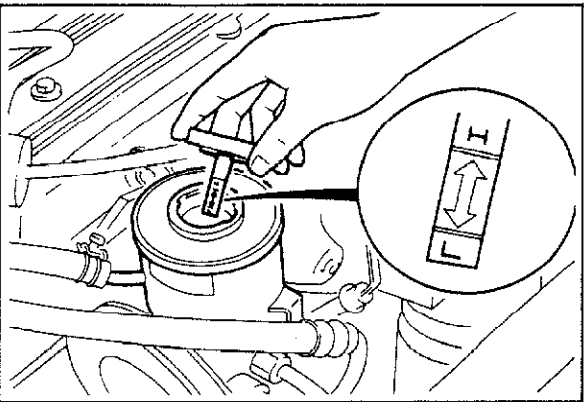

7BU10X-022

## INSPECTION AND ADJUSTMENT

### BLEEDING OF POWER STEERING SYSTEM

1. Jack up the front of the vehicle.

2. Check and add fluid if necessary. Turn the steering wheel fully left and right several times.

3. Recheck the fluid and add as required. Let the vehicle down.

4. Start the engine and run at idle speed. Turn the steering wheel again fully left and right several times. If a noise is heard in the oil line, air is still present.

5. Put the wheels in the straight-ahead position, and turn off the engine. The fluid level in the pump should not increase; if it does, air is present. Repeat item 4 if necessary.

6. Recheck the fluid level, and inspect for leaks.

#### Caution

If the air bleeding is incomplete, raise the oil temperature to about 50—80°C (122—176°F) (the oil temperature will rise when the steering wheel is turned clockwise and counter-clockwise), stop the engine, and perform the operation as in item 4 in 5 to 10 minutes. Air can be completely bled by repeating this operation a couple of times.

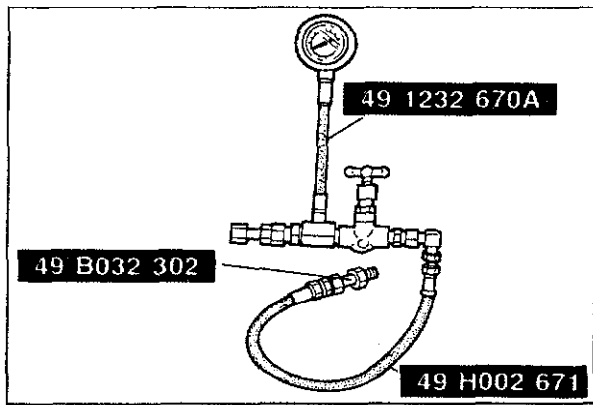

83U10X-008

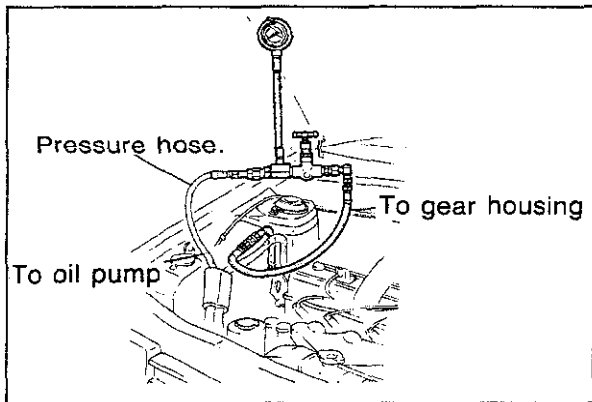

83U10X-009

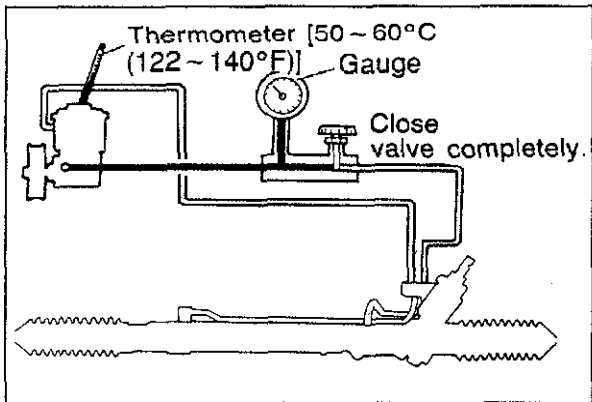

83U10X-010

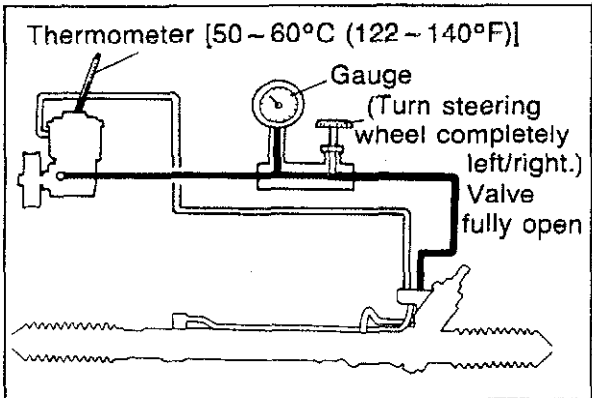

83U10X-011

## POWER STEERING PRESSURE

1. Disconnect the high-pressure hose of the gear housing side, and attach the **SST** so that the valve is connected to the gear housing side.

**Tightening torque: 39—49 N·m**  
(4.0—5.1 m·kg, 29—36 ft·lb)

2. Bleed the air from the system.
3. After opening the gauge valve completely, start the engine and turn the steering wheel fully left and right to raise the fluid temperature to **50—60°C (122—140°F)**.
4. To measure the fluid pressure generated by the oil pump, close the gauge valve completely and increase the engine rpm to **1000—1500 rpm**.

### Oil pump fluid-pressure

**6,867 ±<sup>491</sup>/<sub>245</sub> kPa (70 ±<sup>5.5</sup>/<sub>2.5</sub> kg/cm<sup>2</sup> 995 ±<sup>71</sup>/<sub>36</sub> psi)**

### Warning

**If the valve is left closed for more than 15 seconds, the fluid temperature will increase excessively and adversely affect the oil pump.**

If the fluid pressure is low, replace the oil pump assembly.

5. To measure the fluid pressure generated at the gear housing, first open the gauge valve completely, increase the engine rpm to **1,000—1,500 rpm**, and then turn the steering wheel all the way to the left and right.

### Warning

**If the steering wheel is kept in the fully turned position for more than 15 seconds, the fluid temperature will rise excessively.**

### Gear housing fluid-pressure limit

**6,867 ±<sup>491</sup>/<sub>245</sub> kPa (70 ±<sup>5.5</sup>/<sub>2.5</sub> kg/cm<sup>2</sup> 995 ±<sup>71</sup>/<sub>36</sub> psi)**

If the fluid pressure is low, repair or replace the gear box.

6. After removing the gauge set, tighten the high-pressure hose to the specified torque.
7. Bleed the air from the system. (Refer to page 10—10.)

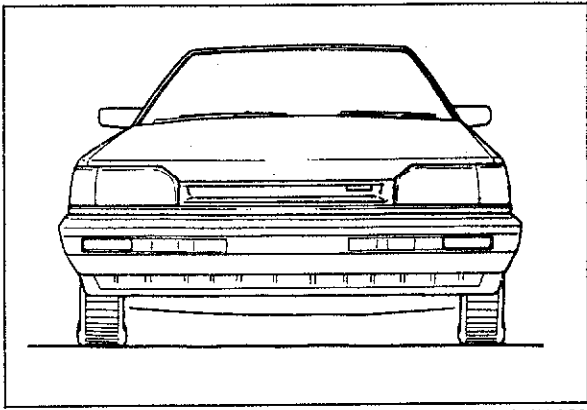

63U10X-022

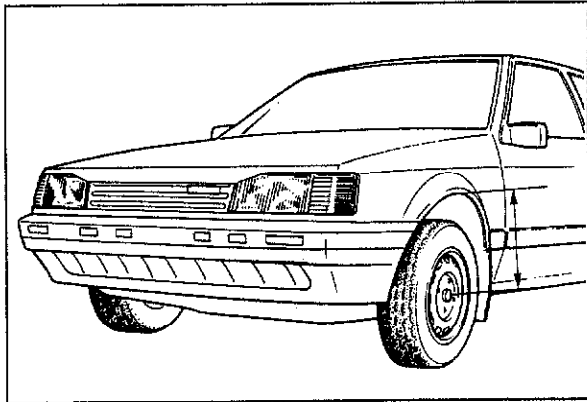

63U10X-023

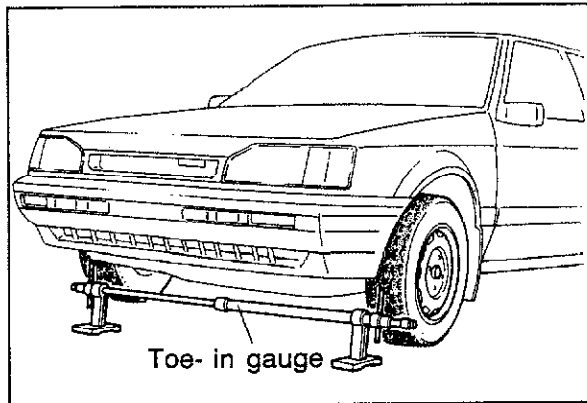

Toe-in gauge

83U10X-012

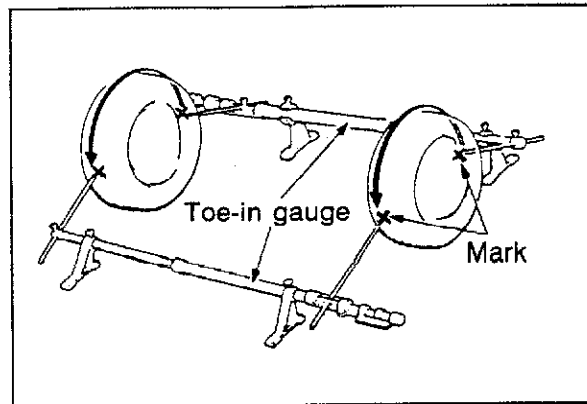

83U10X-013

## FRONT WHEEL ALIGNMENT

### Pre-inspection

1. Check the tire inflation and set to the recommended pressure if necessary.
2. Inspect the front wheel bearing play and correct if necessary.
3. Inspect the wheel and tire run out.
4. Inspect the ball joints and steering linkage for any excessive looseness.
5. The vehicle must be on level ground and have no luggage or passenger load.

6. The difference in height from the center of the wheel to the fender brim between the left and right sides should be within **15 mm (0.59 in)**.

### Toe-in Inspection

1. Raise the front end of the vehicle until the wheels clear the ground.
2. Turn the wheels by hand, mark a line in the center of each tire tread by using a scribing block.
3. Place the front wheels in the straight-ahead position and lower the vehicle.

4. Measure the distance between the marked lines at the front and rear of the wheels.

**Both measurements must be taken at equal distances from the ground.**

If the distance between the wheels at the rear is greater than that at the front by  $2 \pm 3 \text{ mm}$  ( $0.08 \pm 0.12 \text{ in}$ ), it is correct.

### Toe-in

**$2 \pm 3 \text{ mm}$  ( $0.08 \pm 0.12 \text{ in}$ )**

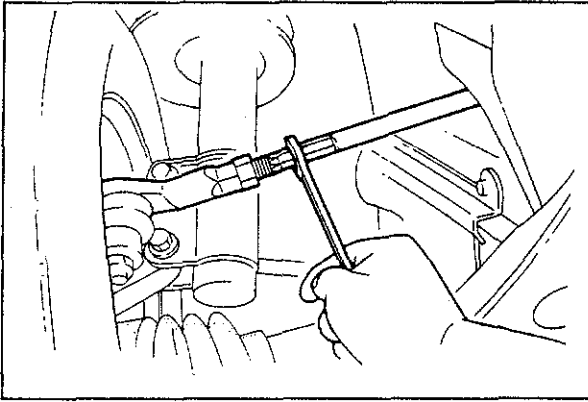

63U10X-025

### Adjustment

To adjust the toe-in, loosen the left and right tie-rod lock nuts, and turn the tie-rods by the same amount.

### Caution

1. The left and right tie-rods are both right threaded, so, to increase the toe-in, turn the right tie-rod toward the front of the vehicle, and turn the left tie-rod by the same amount toward the rear.
2. One turn of the tie-rod (both sides) changes the toe-in by about 6 mm (0.24 in).
3. Adjust the toe-in after adjusting the steering angle.

Tighten the tie-rod lock nuts to the specified torque.

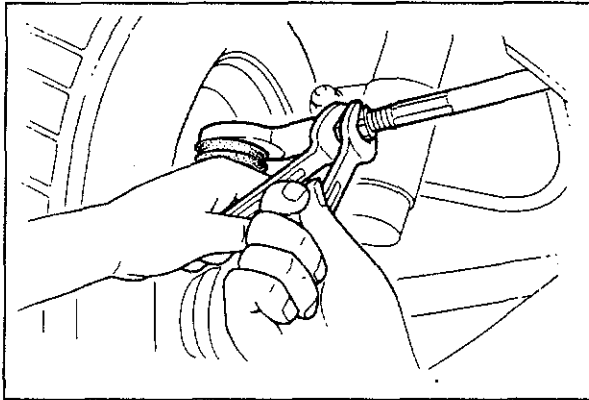

83U10X-014

### Tightening torque

2WD: 34—39 N·m

(3.5—4.0 m·kg, 25—29 ft·lb)

4WD: 34—50 N·m

(3.5—5.1 m·kg, 25—37 ft·lb)

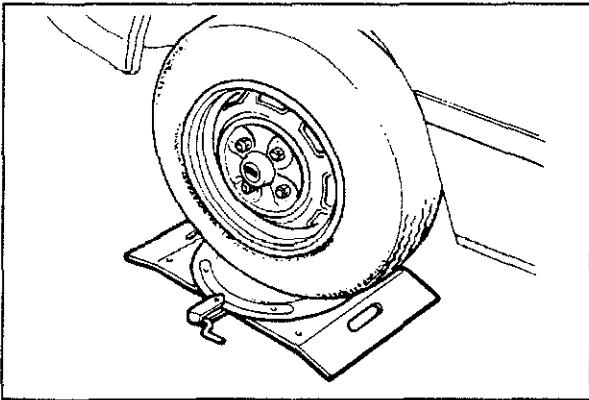

83U10X-015

### Steering Angle (Maximum Angle to the Left and Right)

#### Inspection

The steering angle is measured by placing the front wheels on a turning-radius gauge.

#### Steering angle:

	2WD	4WD
Inner	40°00' ± 2°	39°00' ± 2°
Outer	33°00' ± 2°	31°00' ± 2°

### Adjustment

The steering angle is adjusted by loosening the tie-rod lock nuts and turning the tie-rods.

### Caution

Adjust so that left and right steering is the same and the steering wheel is centered in the straight ahead position.

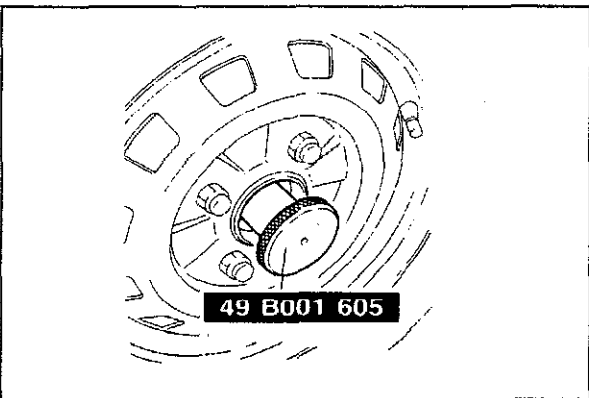

63U10X-028

### Camber and Caster

#### Inspection

The camber and caster are measured by placing the front wheels on a turning-radius gauge.

1. Jack up the vehicle and remove the wheel cap and wheel hub nut. Then attach the **SST** to the wheel hub as shown in the figure.

# 10 INSPECTION AND ADJUSTMENT

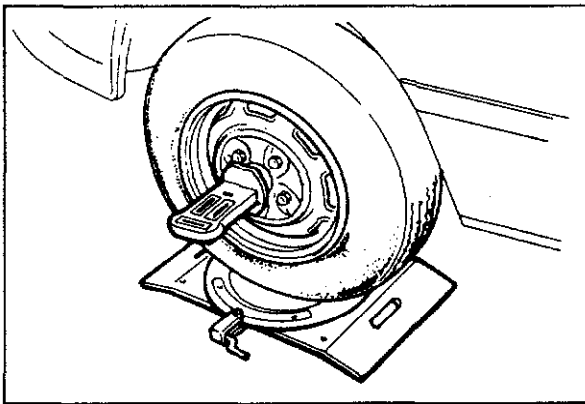

83U10X-016

2. Attach the caster/camber gauge to the adapter, and then measure the camber and caster.

	2WD	4WD
<b>Camber angle</b>	$0^{\circ}50' \pm 30'$	$1^{\circ}00' \pm 30'$
<b>Caster angle</b>	$1^{\circ}35' \pm 45'$	$1^{\circ}45' \pm 45'$

**Left/right difference:**  
Camber: 30' or less  
Caster: 40' or less

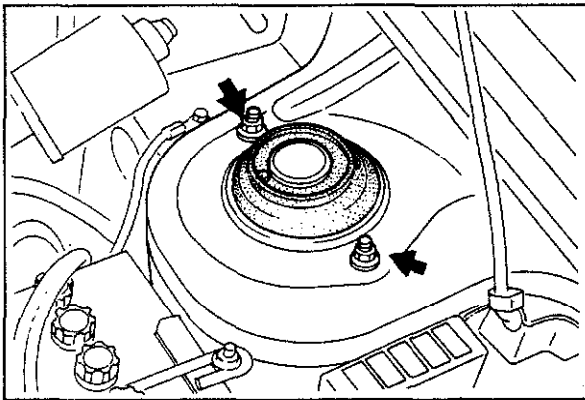

83U10X-017

## Adjustment

### Note

The camber is adjustable by 28' to either negative or positive side, the caster is not adjustable.

1. Jack up the front of the vehicle and support it with safety stands.
2. Open the hood.
3. Remove the two nuts mounting the shock absorber mounting block to the fender.
4. Push the mounting block downward, turn it 180°, mount it on the fender again and tighten it to the specified torque.

**Tightening torque: 23—29 N·m**  
(2.0—3.0 m·kg, 14—22 ft·lb)

### Note

When the white mark on the mounting block is rotated from the engine side to the outside, the camber change is negative.

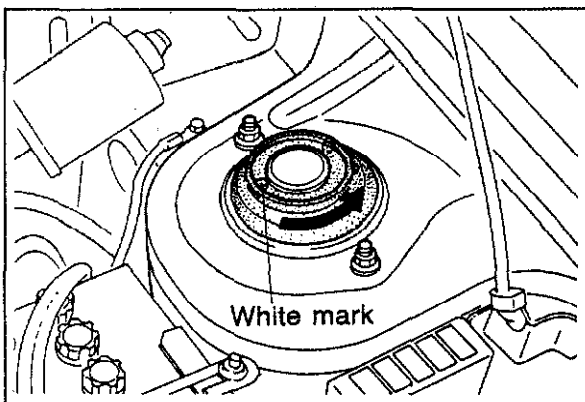

83U10X-018

# TIE-ROD END BOOT

## REMOVAL AND INSTALLATION

1. Jack up the front of the vehicle and support it with safety stands.
2. Remove in the sequence shown in the figure.
3. Install in the reverse order of removal.

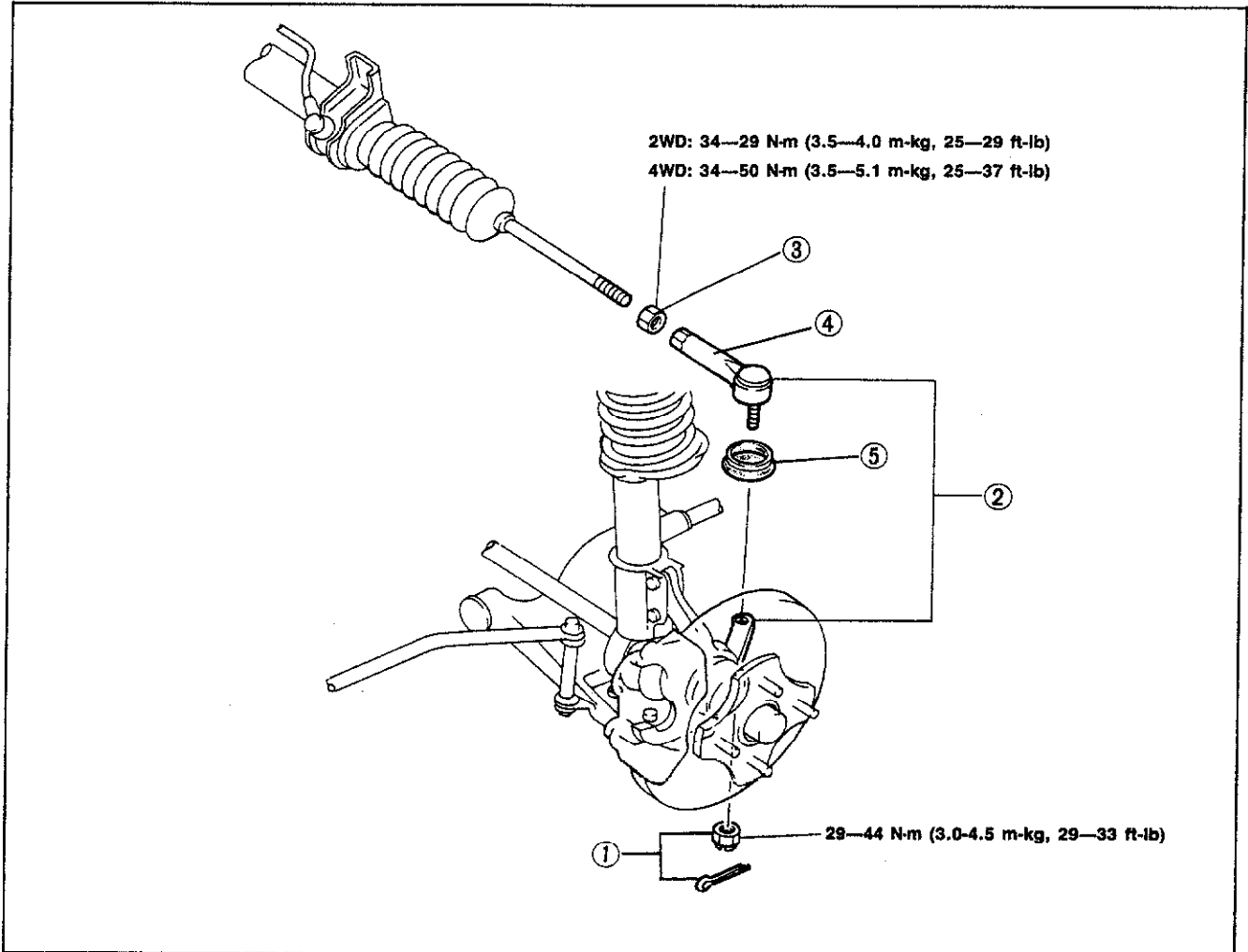

83U10X-019

- |                        |                |         |
|------------------------|----------------|---------|
| 1. Cotter pin and nut  | 3. Locknut     | 5. Boot |
| 2. Tie-rod end/knuckle | 4. Tie-rod end |         |

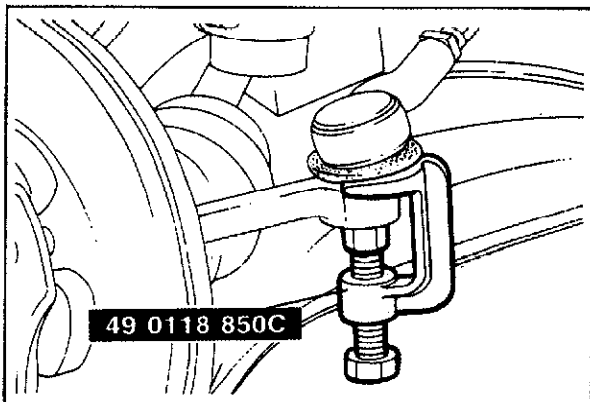

83U10X-020

### Tie-rod End/Knuckle

Separate the tie-rod end from the knuckle with the SST.

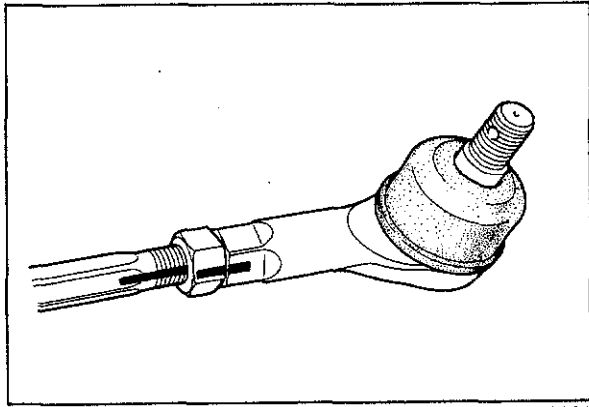

83U10X-034

## Locknut

Before loosening the locknut from the tie-rod end, make a mark for reference during installation. Tighten the nut to that mark during installation.

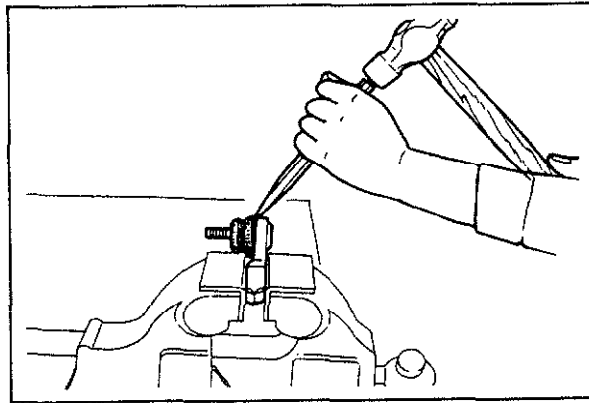

83U10X-035

## Boot Removal

1. Secure the tie-rod end in a vise.
2. Place a chisel against the boot and hold it at the angle shown in the figure.
3. Remove the boot by tapping the chisel with a hammer.

## Caution

**Be careful not to scar the part where the boot is attached to the tie-rod end.**

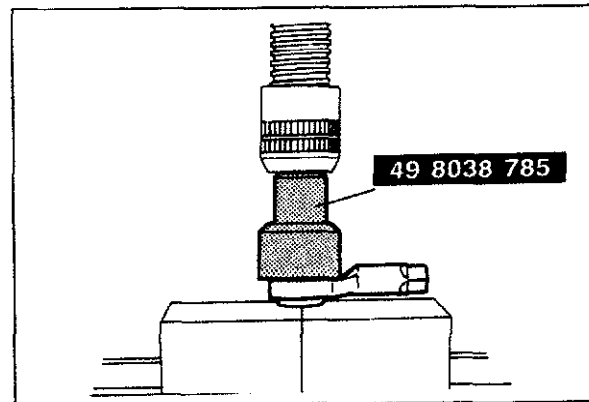

83U10X-021

## Installation

1. Insert a small amount of grease (lithium base, NLGI No. 2) into the new boot and set it onto the **SST**.
2. Install the boot to the tie-rod end using a press.



## STEERING WHEEL AND COLUMN

### REMOVAL AND INSTALLATION

1. Jack up the vehicle and support it with safety stands.
2. Disconnect the battery negative cable.
3. Remove in the sequence shown in the figure.
4. Install in the reverse order of removal.

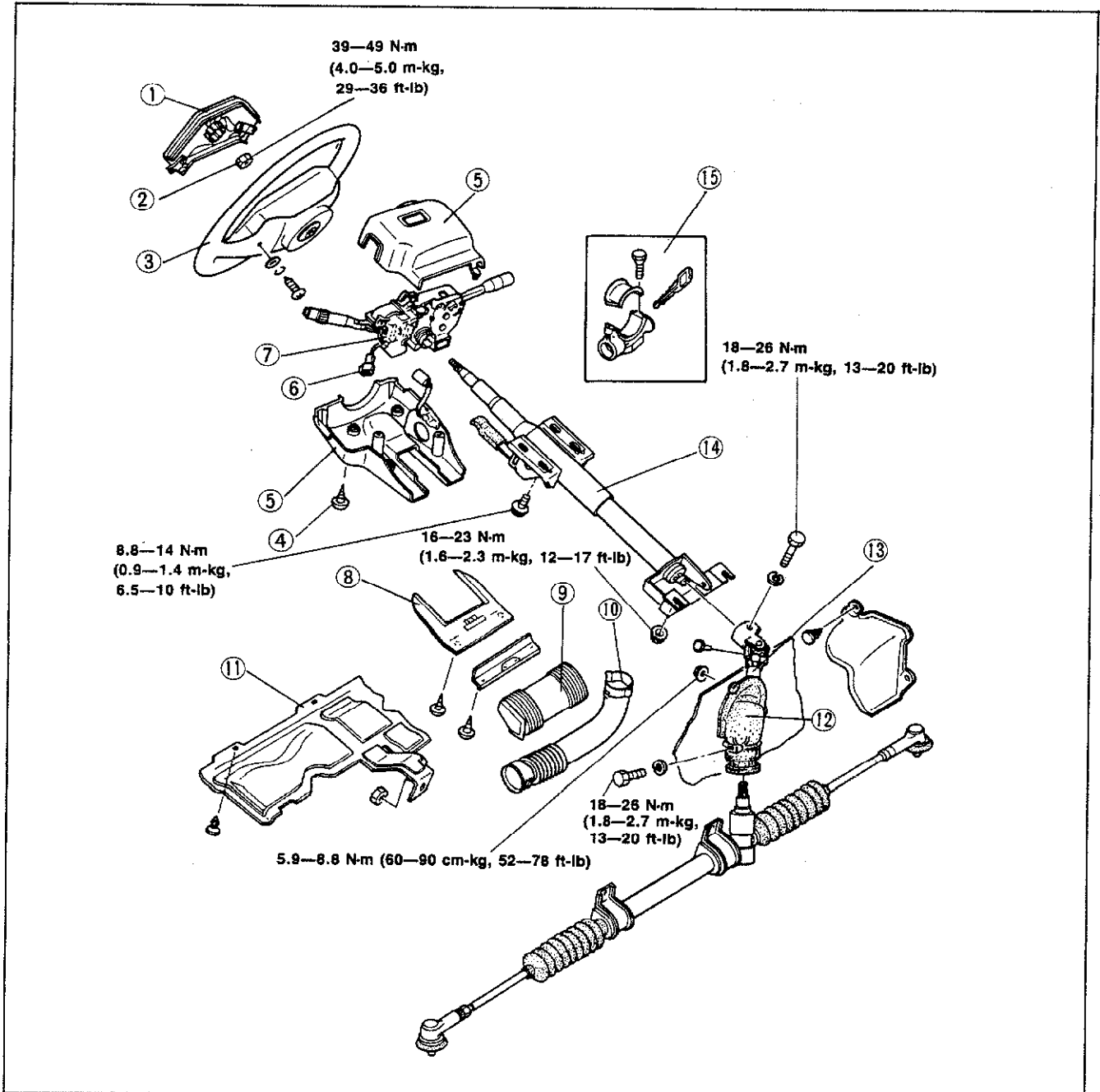

83U10X-022

- |                   |                       |                        |
|-------------------|-----------------------|------------------------|
| 1. Horn cap       | 6. Harness couplers   | 11. Under cover        |
| 2. Lock nut       | 7. Combination switch | 12. Dust boot          |
| 3. Steering wheel | 8. Lower panel        | 13. Intermediate shaft |
| 4. Screw          | 9. Lower louver       | 14. Steering shaft     |
| 5. Column cover   | 10. Demister duct     | 15. Steering lock      |

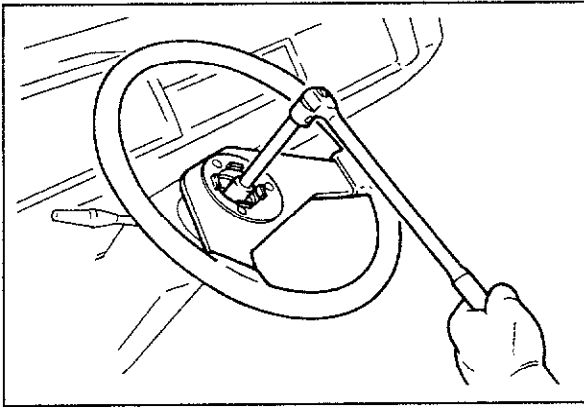

83U10X-023

### Steering Wheel

1. Remove the horn cap by removing the screws, and remove the locknut.

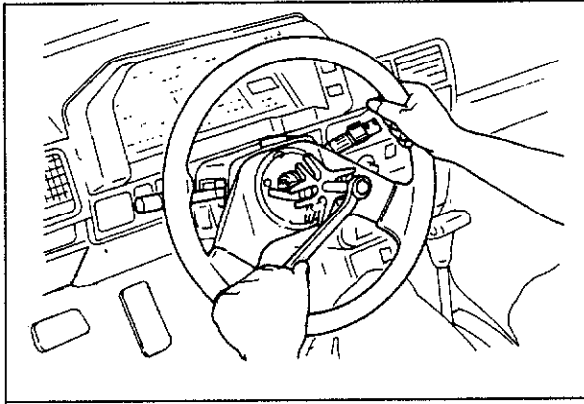

83U10X-024

2. The steering wheel must be removed using a suitable puller.

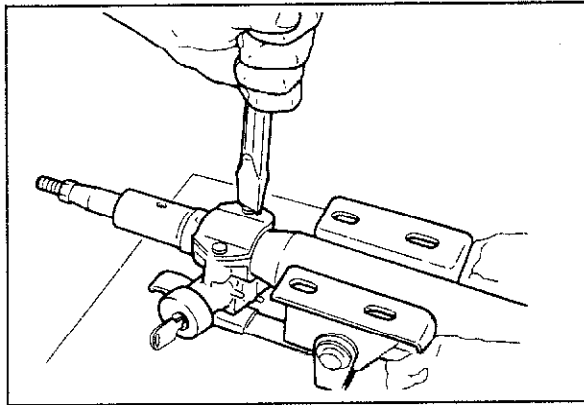

63U10X-040

### Steering Lock

1. Use a chisel to make a groove in the head of the steering-lock installation screw. Remove the screw by using a flat-tipped screwdriver, and then remove the steering lock.

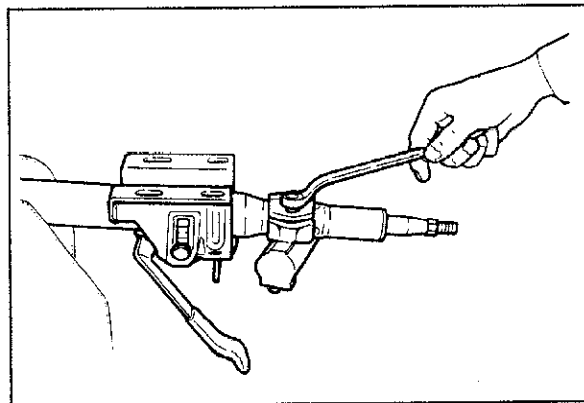

63U10X-041

2. After installing the steering lock to the jacket, use new steering lock mounting screws, and screw them in until the neck of the screw breaks off.

### Caution

**Tighten the steering lock mounting screws while checking the lock operation.**

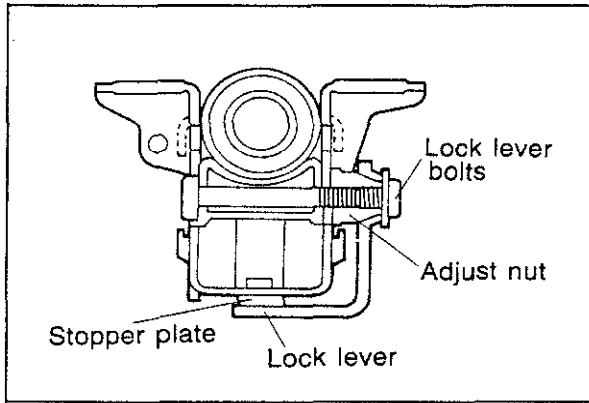

63U10X-042

### Tilt Steering Lock Lever Adjustment

1. When installing, lift the steering column to the highest position and tighten the adjust nut.

**Tightening torque: 5—9 N·m  
(0.5—0.9 m·kg, 3.6—6.5 ft·lb)**

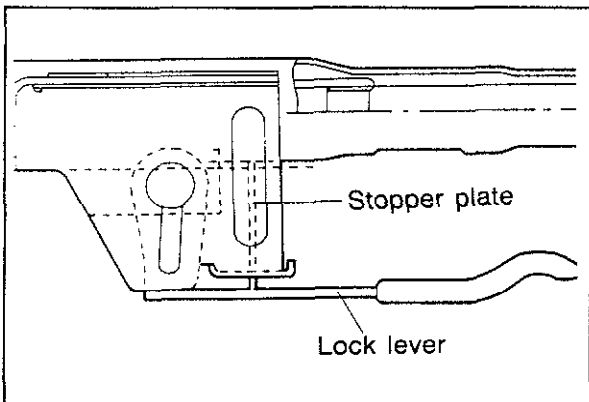

63U10X-043

2. Install and set the steering lock lever so that it touches the stopper plate, and then tighten the lock lever bolt.

**Tightening torque: 18—27 N·m  
(1.8—2.7 m·kg, 13.0—19.5 ft·lb)**

3. Check that the lock lever operates smoothly and locks securely.

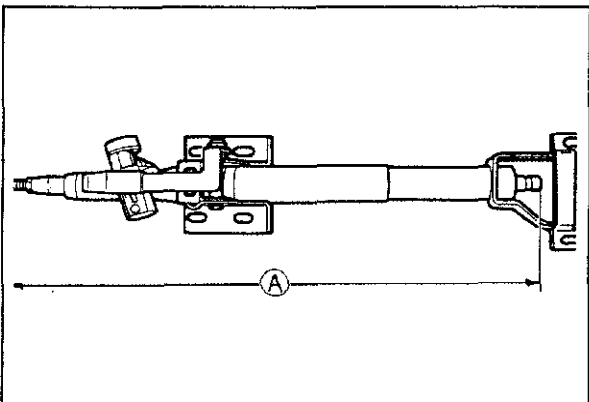

63U10X-044

### INSPECTION

Check the following points, replace parts if necessary.

1. Dimensions of steering column

**Standard dimensions (A):  
607 ± 1 mm (23.89 ± 0.039 in)**

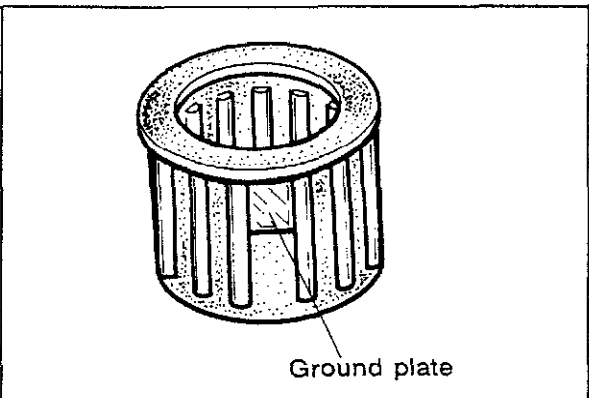

63U10X-045

2. Wear of column bearing
3. Ground plate for damage and tension

# 10 STEERING WHEEL AND COLUMN

---

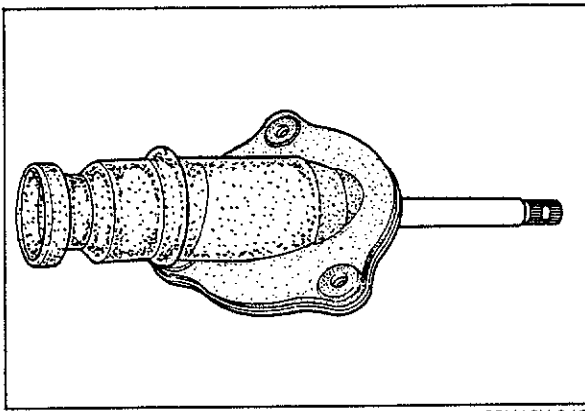

63U10X-046

- 4. Joint for excessive play
- 5. Dust boot for damage

## STEERING GEAR AND LINKAGE

### REMOVAL AND INSTALLATION (2WD)

1. Loosen the front wheel lug nuts.
2. Jack up the vehicle and support it with safety stands.
3. Disconnect the battery negative cable.
4. Remove the wheels.
5. Remove the under cover.
6. Remove the parts in the sequence shown in the figure.
7. Install in the reverse order of removal.
8. After installation, add the power steering fluid and bleed air, then check for fluid leakage.

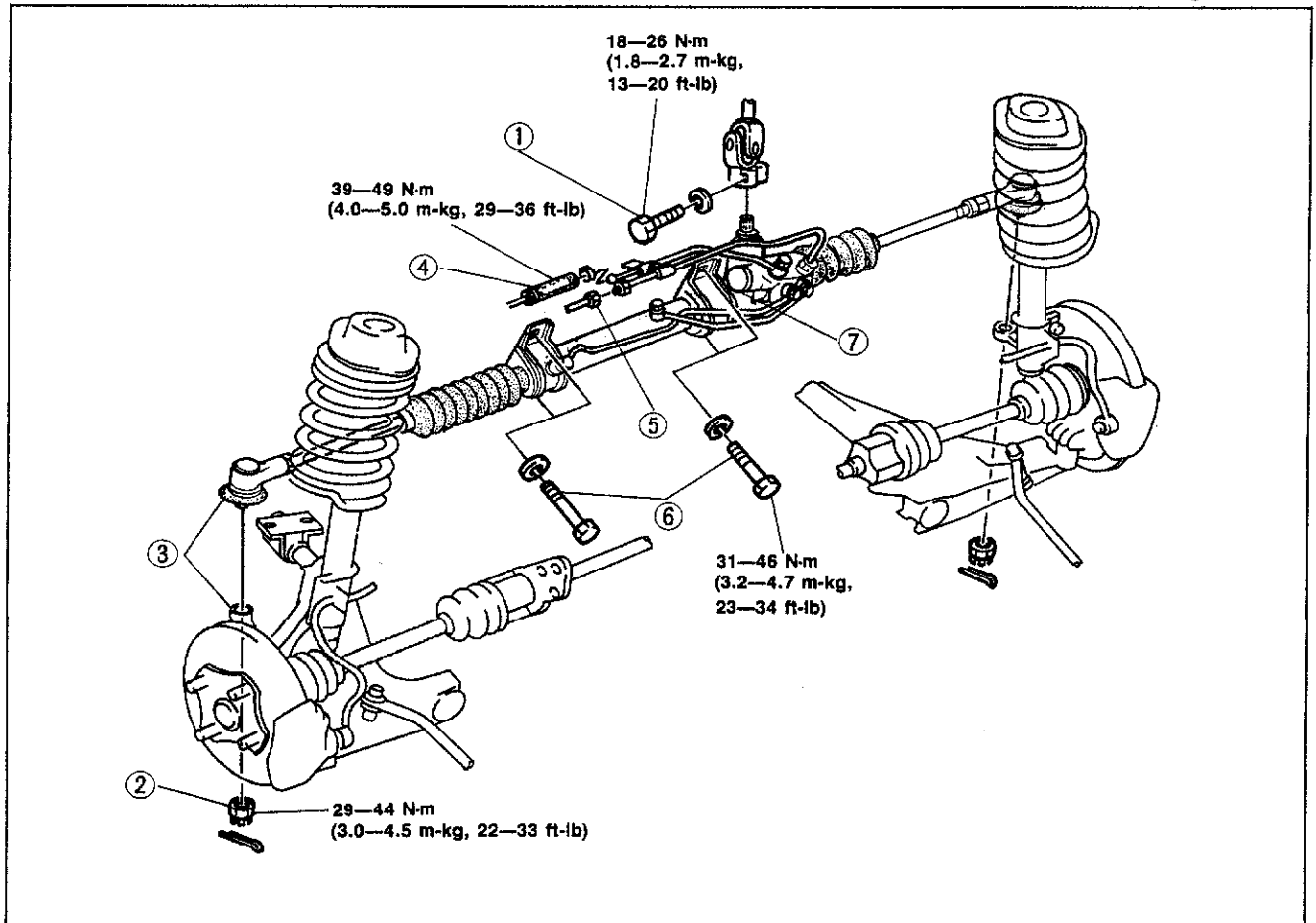

83U10X-025

- |                                      |                                      |                              |
|--------------------------------------|--------------------------------------|------------------------------|
| 1. Bolt                              | 4. Return hose<br>(Power steering)   | 6. Bolts                     |
| 2. Nut and cotter pin                | 5. Pressure pipe<br>(Power steering) | 7. Steering gear and linkage |
| 3. Knuckle arm/tie-rod<br>connection |                                      |                              |

# 10 STEERING GEAR AND LINKAGE

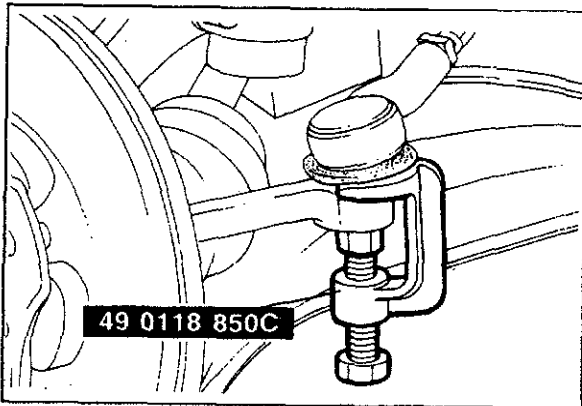

83U10X-026

## Tie-rod end

Separate the left and right tie-rod ends from the knuckle with the **SST**.

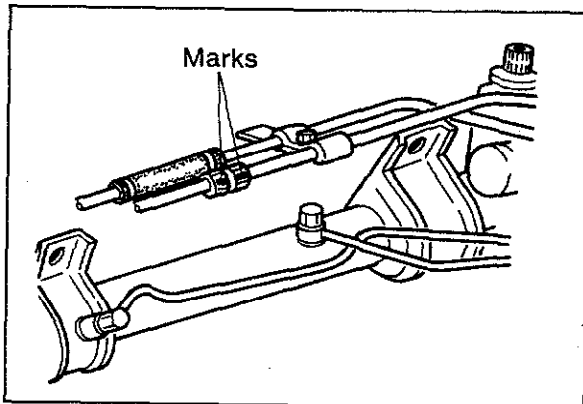

73G10X-011

## Oil Pipes

Make marks on the pressure pipe nuts for proper reinstallation, and then disconnect it.

### Note

**Power steering fluid will leak out when the pressure pipe or the return hose is disconnected, so prepare a suitable container for it to drain into.**

## REMOVAL AND INSTALLATION (4WD)

1. Loosen the front wheel lug nuts.
2. Jack up the front of the vehicle and support it with safety stands.
3. Remove the wheels.
4. Remove the bonnet.
5. Remove the battery, battery tray, and carrier.
6. Remove the under covers.
7. Remove in the sequence shown in the figure.
8. Install in the reverse order of removal.
9. After installation, add power steering fluid and bleed air, then check for fluid leakage.

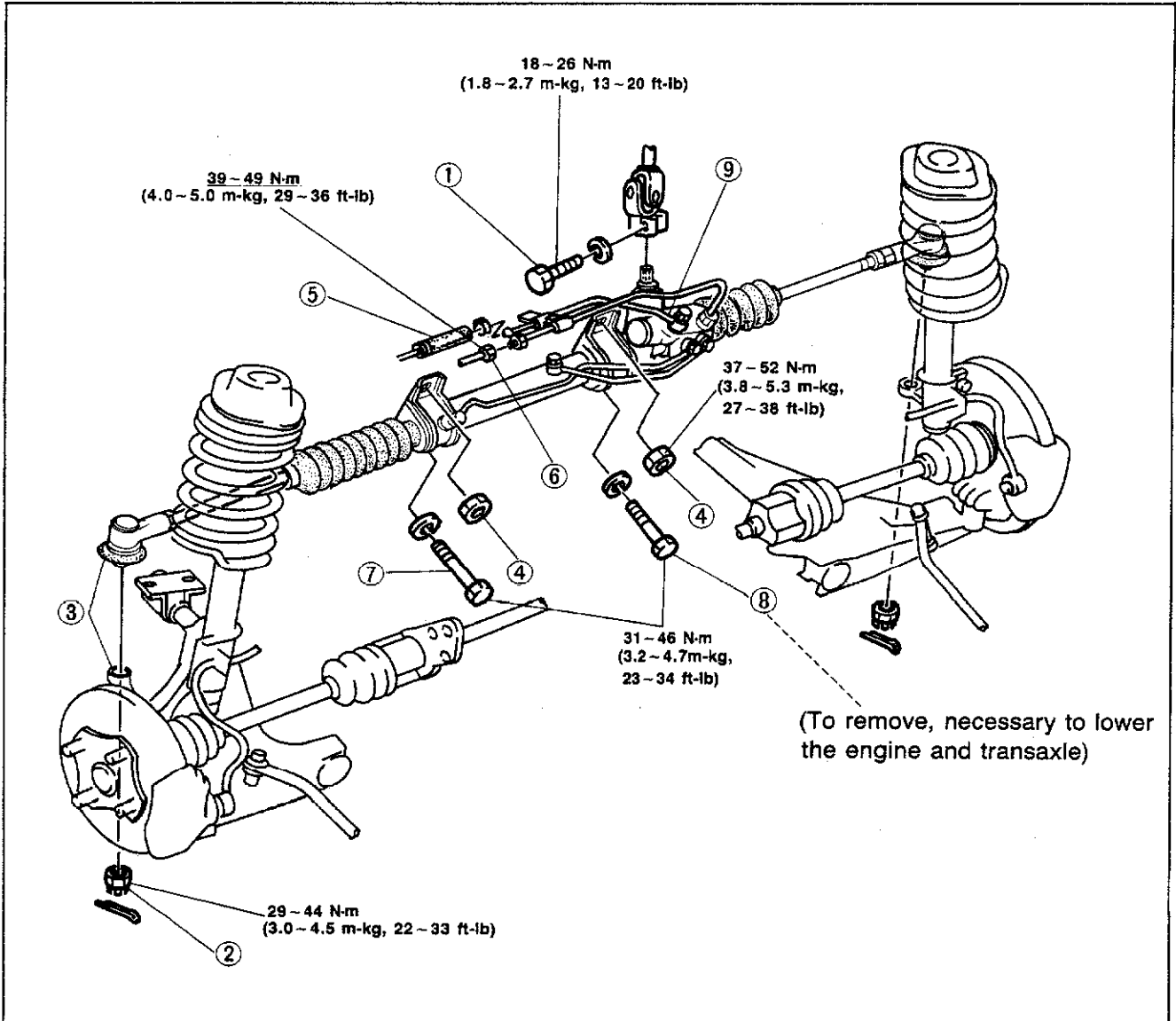

83U10X-027

1. Bolt
2. Nut and cotter pin
3. Knuckle arm/tie-rod

4. Nut
5. Return hose
6. Pressure pipe

7. Bolt (right)
8. Bolt (left)
9. Steering gear and linkage

# 10 STEERING GEAR AND LINKAGE

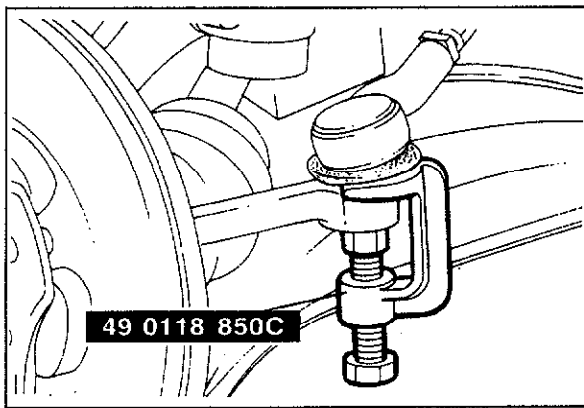

83U10X-026

## Tie-rod end

Separate the left and right tie-rod ends from the knuckle with the **SST**.

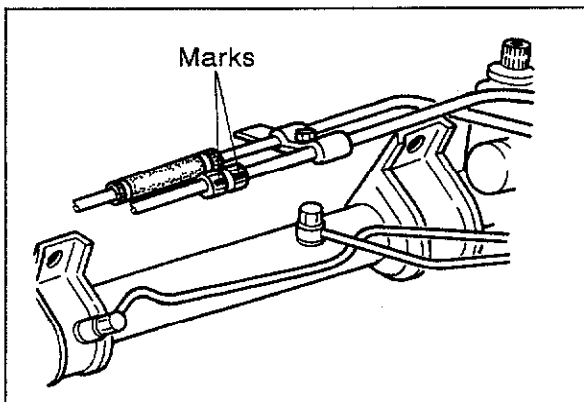

73G10X-011

## Oil Pipes

Make marks on the pressure pipe nuts for proper reinstallation, and then disconnect it.

## Note

**Power steering fluid will leak out when the pressure pipe or the return hose is disconnected, so prepare a suitable container for it to drain into.**

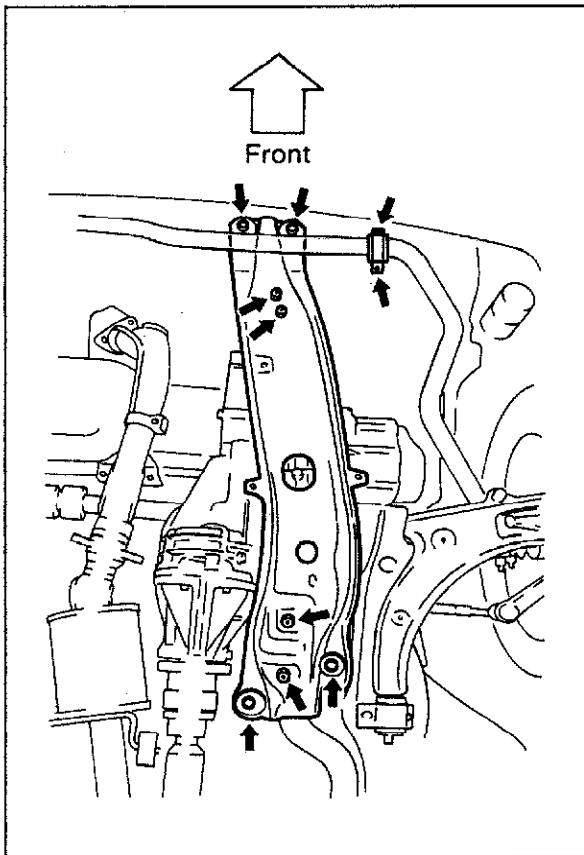

83U10X-028

## Mounting Nut (lower left)

To remove, proceed in the following order.

1. Loosen the stabilizer mounting bracket nut and bolt.
2. Remove the engine mount member.



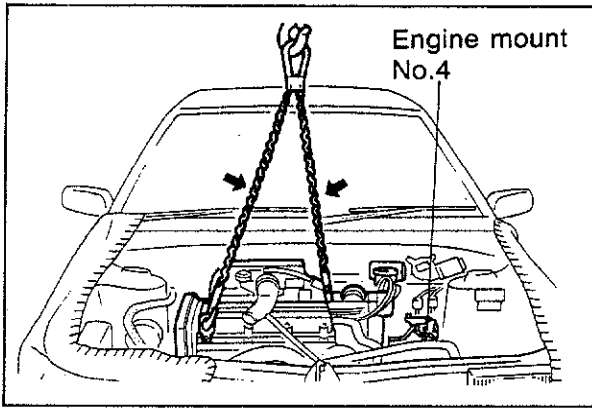

73G10X-013

- Hook a chain and engine hoist to the engine and transaxle, and put slight tension on the chain.

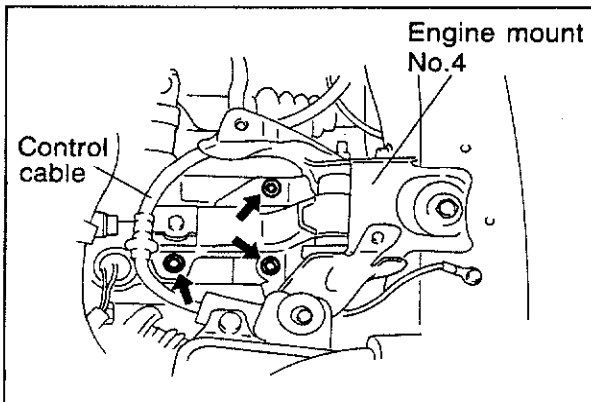

73G10X-014

- Remove the transmission control cable clip.
- Remove the nuts mounting the transfer unit to engine mount No.4.

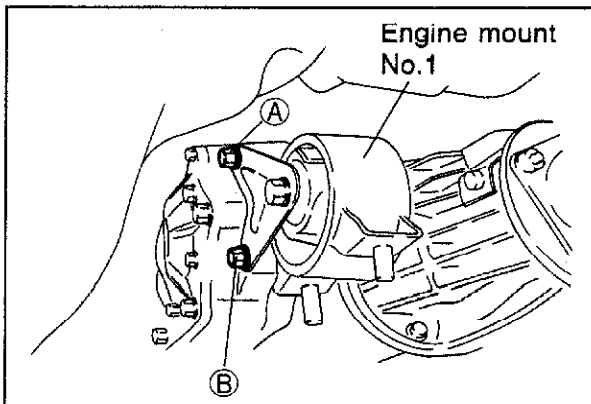

73G10X-015

- Lower the engine gradually until bolt (A) can be removed.

**Caution**

**Do not lower the engine too much because it will damage the driveshaft boots.**

- Remove bolts (A) and (B) and remove engine mount No.1.

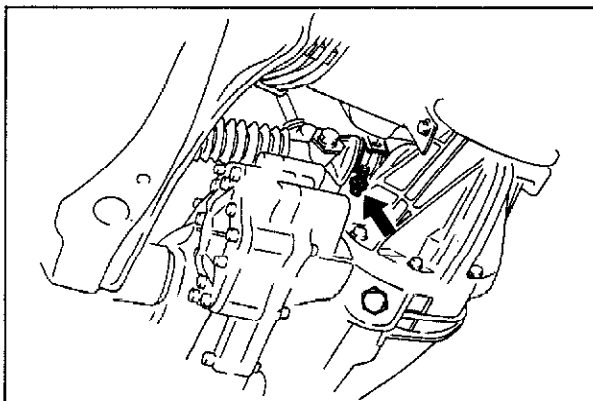

73G10X-016

- Remove the lower left mounting bolt.

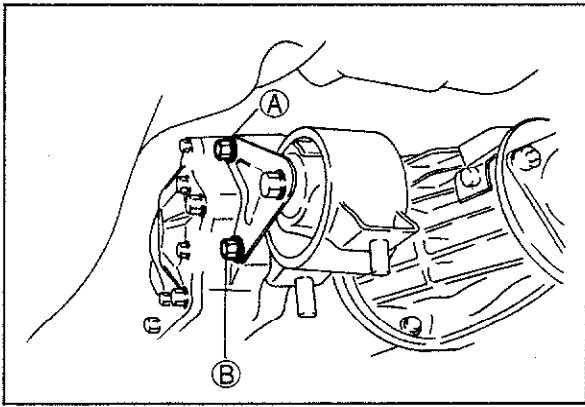

83U10X-029

## Tightening Engine Mount No.2 to Transfer

Bolt **A** and **B** tightening torque:  
37—52 N·m  
(3.8—5.3 m·kg, 27—38 ft·lb)

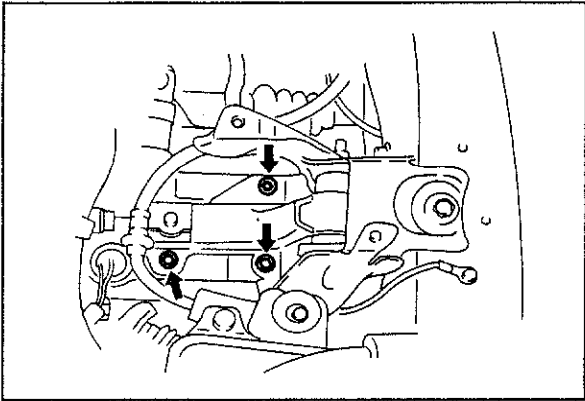

73G10X-019

## Engine Mount No.4 to Transfer

Tightening torque:  
19—25 N·m  
(1.9—2.6 m·kg, 14—19 ft·lb)

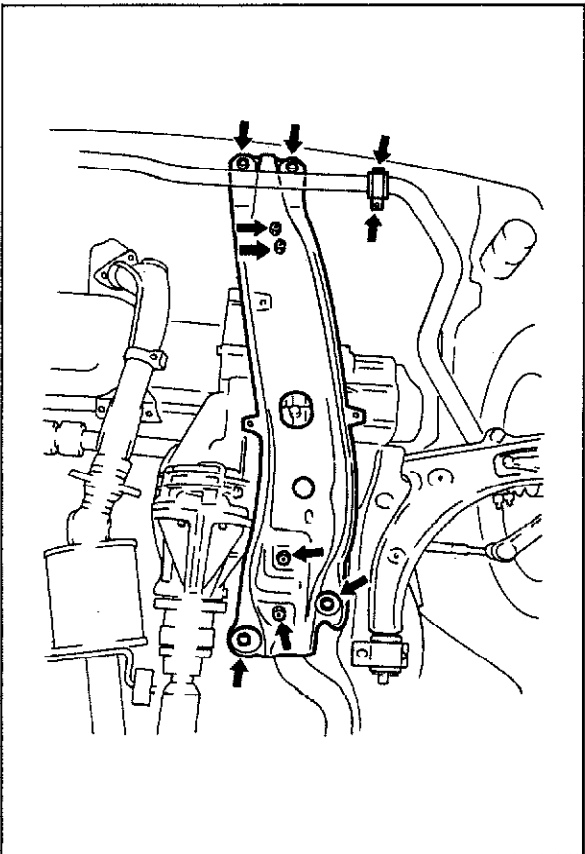

73G10X-020

## Engine Mount No.1 and No.2 to Engine Mount Member

Tightening torque:  
64—89 N·m  
(6.5—9.1 m·kg, 47—66 ft·lb)

## Engine Mount Member to Body

Tightening torque:  
64—89 N·m  
(6.5—9.1 m·kg, 47—66 ft·lb)

## Stabilizer Bracket

Nut and bolt tightening torque:  
31—46 N·m  
(3.2—4.7 m·kg, 23—34 ft·lb)

## DISASSEMBLY (MANUAL STEERING, CONSTANT GEAR RATIO TYPE)

Disassemble in the sequence shown in the figure.

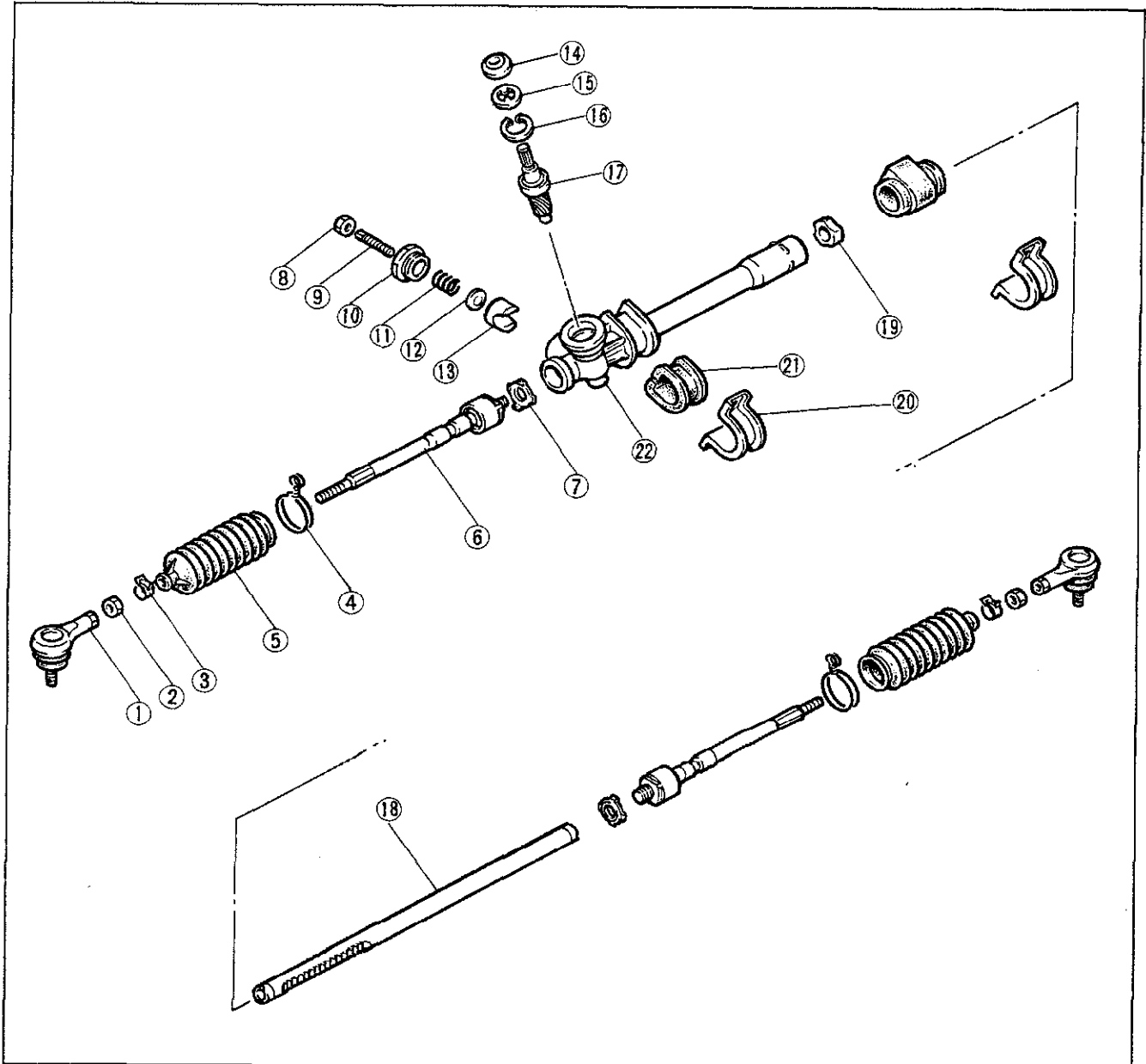

83U10X-030

- |                             |                  |                      |
|-----------------------------|------------------|----------------------|
| 1. Tie-rod end (left/right) | 8. Locknut       | 15. Stop ring        |
| 2. Nuts (left/right)        | 9. Adjust Bolt   | 16. Snap ring        |
| 3. Boots clip (left/right)  | 10. Adjust cover | 17. Pinion           |
| 4. Boot wire (left/right)   | 11. Yoke spring  | 18. Rack             |
| 5. Boot (left/right)        | 12. Spacer       | 19. Bushing          |
| 6. Tie-rod (left/right)     | 13. Support yoke | 20. Mounting bracket |
| 7. Washer (left/right)      | 14. Dust cover   | 21. Rubber mount     |
|                             |                  | 22. Gear housing     |

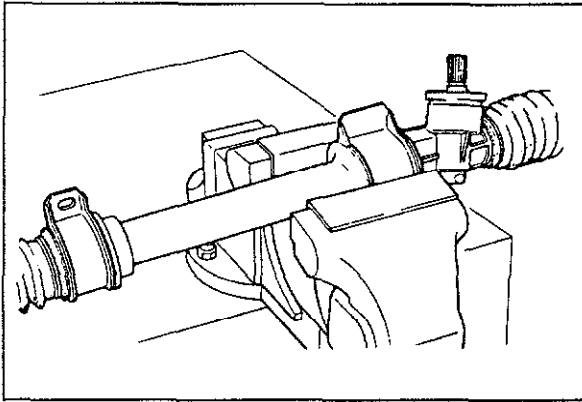

63U10X-049

## Steering gear and linkage

Secure the mounting of the removed gear and linkage in a vise.

### Caution

Be sure to insert a soft, protective material (such as copper plates) between the part and the jaws of the vise.

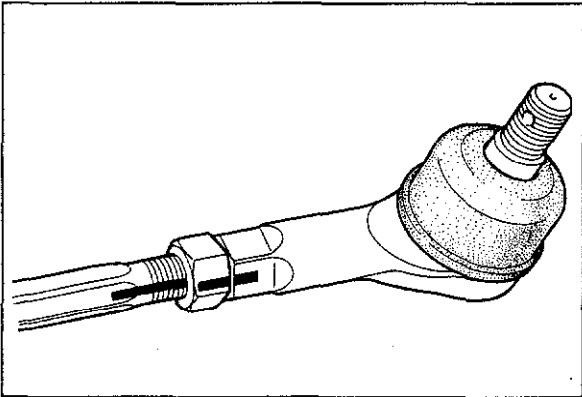

63U10X-050

## Tie-rod ends

Before removing the tie-rod ends, make a mark on the threaded part of the tie-rods to use as a guide for installation.

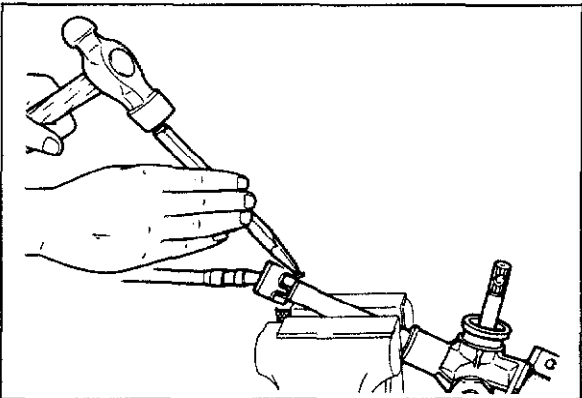

63U10X-051

## Tie-rods

When removing each of the tie-rods from the rack, proceed as follows:

1. Un-crimp the washer as shown in the figure.

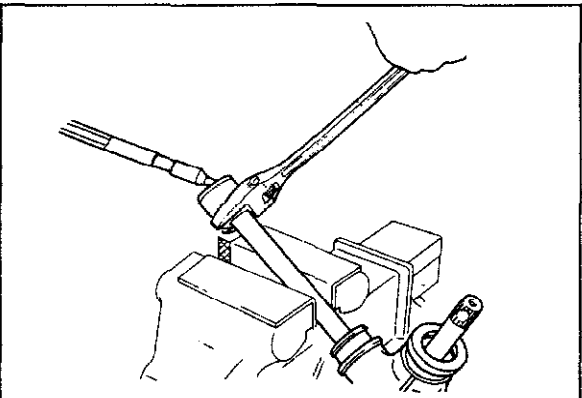

63U10X-052

2. Using an adjustable wrench on the notch of the rack gear and an open-end wrench at the tie-rod, turn the tie-rod, and separate the tie-rod and rack.

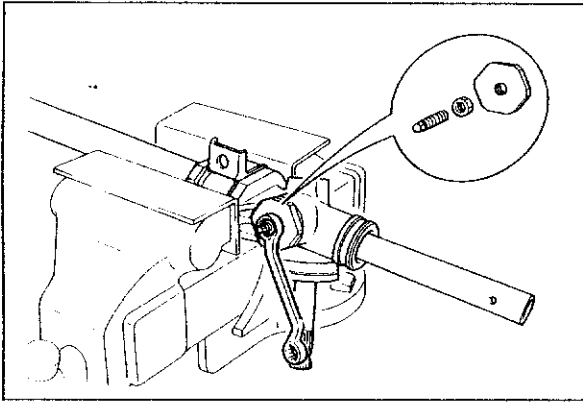

83U10X-031

## Adjust Cover

Remove the locknut and remove the adjust bolt and the adjust cover.

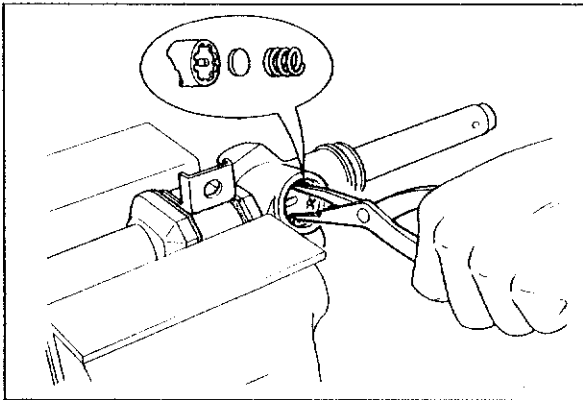

73U10X-004

## Support Yoke

Remove the parts in the following order:

- (1) Yoke spring
- (2) Spacer
- (3) Support yoke

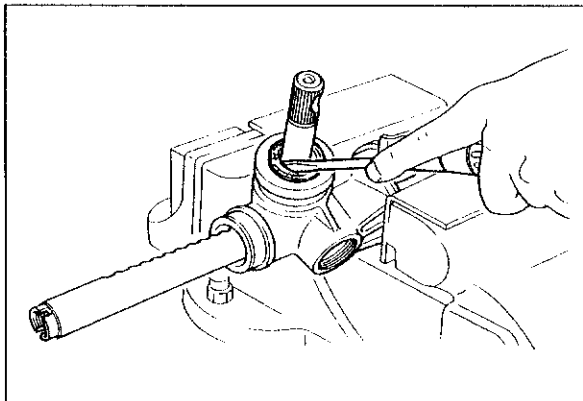

73U10X-005

## Stop ring

1. Remove the oil seal using a small flat-tipped screw driver.
2. Remove the stop ring.

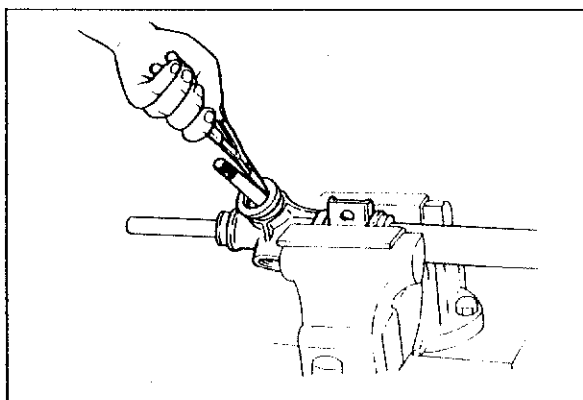

73U10X-006

## Pinion Shaft Assembly

Remove the snap ring and remove the pinion shaft assembly from the gear housing.

# 10 STEERING GEAR AND LINKAGE

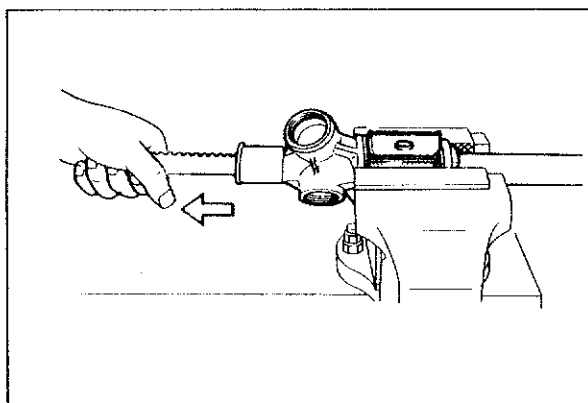

63U10X-056

## Rack

Remove the rack by taking it out in the direction indicated by the arrow.

## Caution

If the rack is taken out in the opposite direction, the inside surface of the rack bushing might be damaged by the edge of the rack gear.

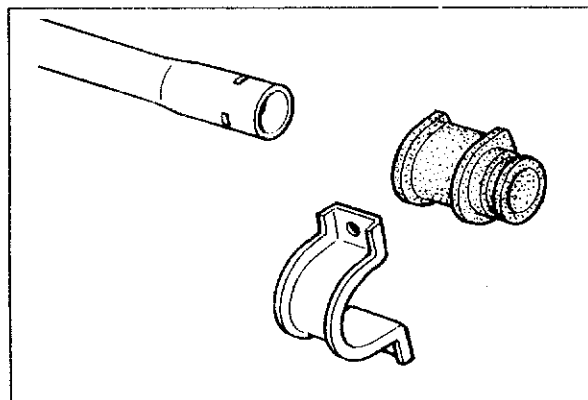

83U10X-032

## Bushing

1. Remove the rubber mount from the housing.

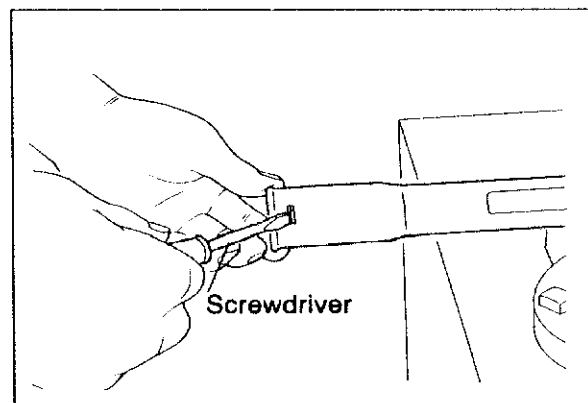

63U10X-059

2. Unlock the bushing from the housing by pushing against each of the three lock points with a flat blade screwdriver.

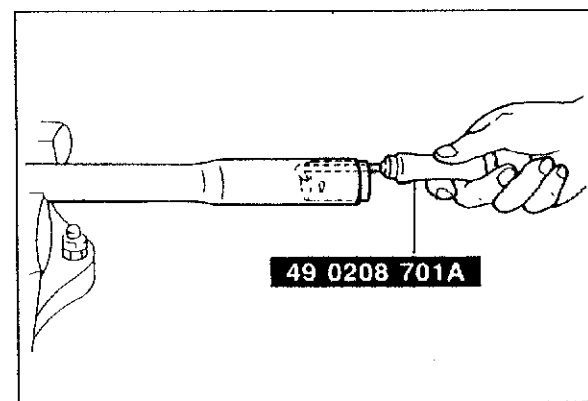

83U10X-033

3. Remove the bushing with the **SST**.

## Note

After removing the bushing, clean the inside of the housing.

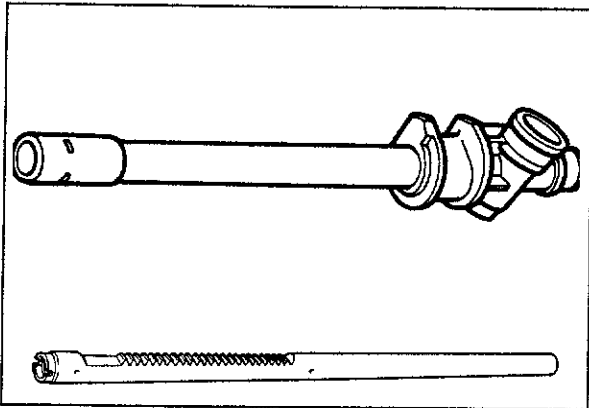

63U10X-061

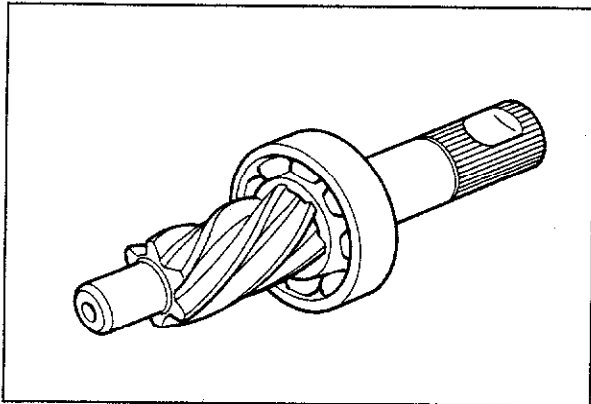

63U10X-062

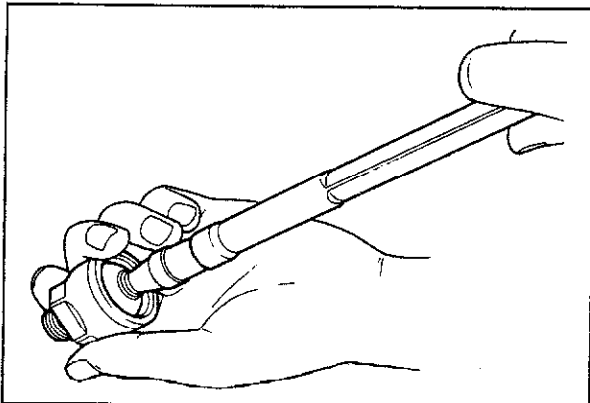

63U10X-063

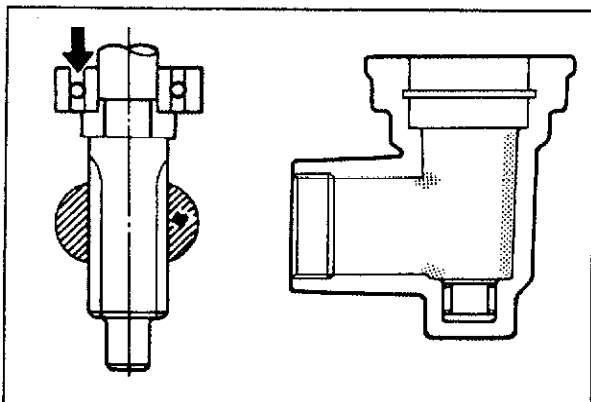

73G10X-026

## INSPECTION

Check the following points, replace the part if necessary.

1. Cracking, damage, or deterioration of boots
2. Cracking, worn teeth, or damage of rack and pinion
3. Looseness, abnormal noise, or poor operation of bearings.

4. Worn rack bushing inside the gear housing

## Caution

a) If replacement is necessary, replace the entire gear housing assembly.

b) Abnormal noise or rough movement of the bearing

c) If pinion bearing replacement is necessary, replace the pinion and bearing as an assembly.

5. Wear of contact surface of pressure pad which contacts rack
6. Cracking or deformation of gear housing
7. Looseness or tie-rod ball-joint operation
8. Bent tie-rods or tie-ends
9. Damage to tie-rods or tie-rod ends.

## ASSEMBLY

Assemble in the following order.

1. Fill or coat with grease.

Before assembly, coat (or fill) the following parts with grease (lithium base, NLGI No.2).

Amount: about 30g (1.06 oz)

- (1) Pinion bearing and teeth
- (2) Inside the gear housing

# 10 STEERING GEAR AND LINKAGE

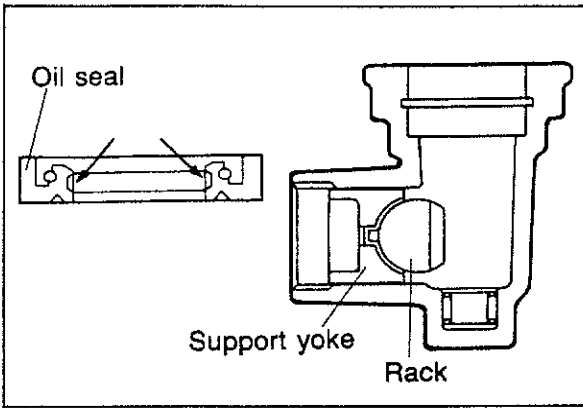

63U10X-066

- (3) Oil seal lip
- (4) Support yoke and rear surface

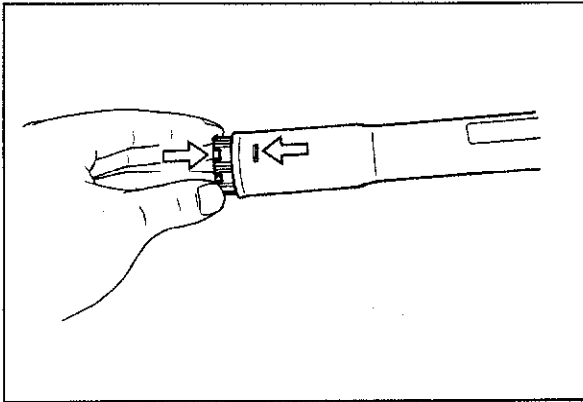

63U10X-067

- 2. Installation of rack bushing  
Install the rack bushing to the rack housing so that the convex part of the rack bushing lines up with the slit of the rack housing.

**Note**

**Apply grease (lithium base, NLGI No.2) to the inside of the bushing.**

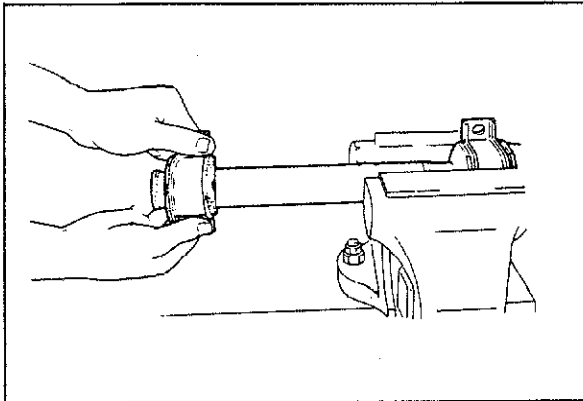

83U10X-034

- 3. Push the rubber mount on until it just contacts the end of the housing.

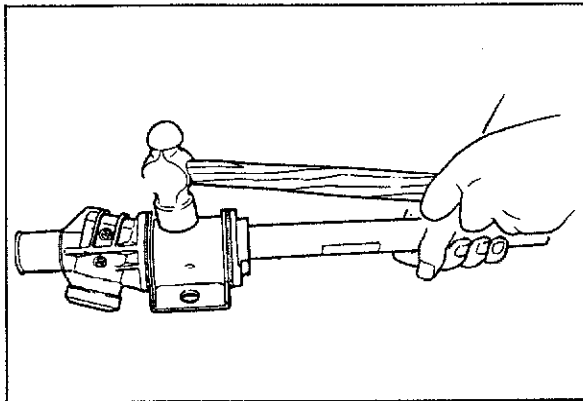

63U10X-077

- 4. Attach the rubber mount to the column.

**Caution**

- a) Be sure that the direction of insertion and the alignment are correct.
- b) Be sure that the mount is aligned with the end of the column.
- c) If the rubber mount is difficult to install, apply soapy water to the inside of the mount.



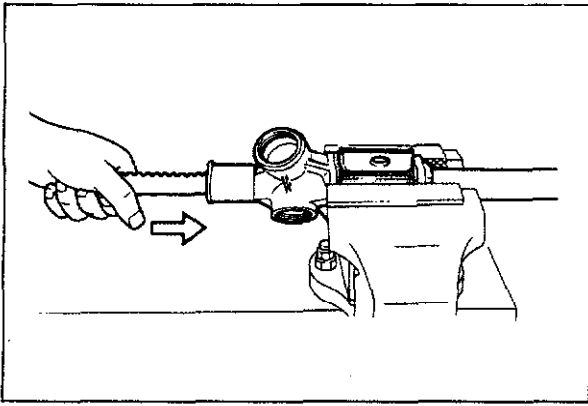

63U10X-069

5. Carefully install the rack in the direction of the arrow.

**Caution**

If the rack is installed from the opposite direction, the inner surface of the rack bushing might be damaged by the edge of the rack gear.

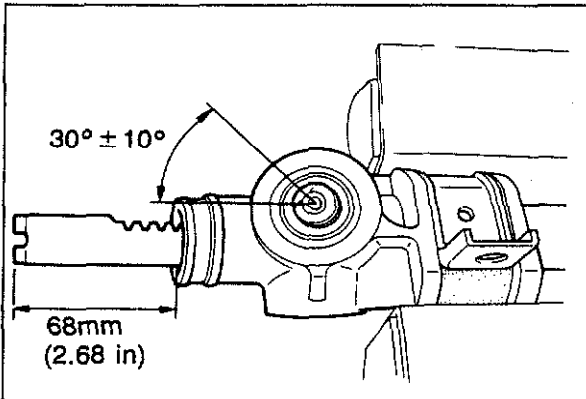

73U10X-007

6. Install the pinion shaft with the notch on the serration positioned as shown in the figure when the rack is positioned at the center of the rack housing.

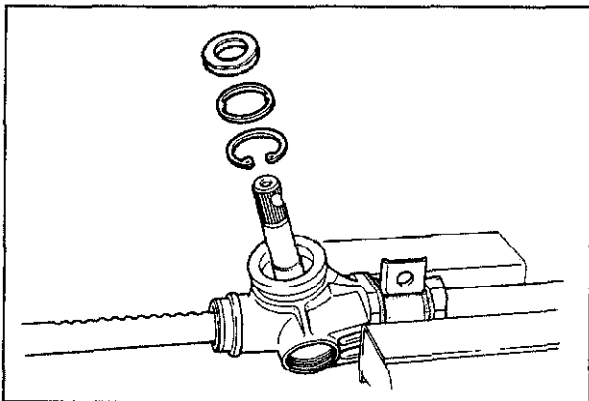

73G10X-028

7. Install the oil seal as follows:  
 (1) Install the snap ring

**Caution**

a) Use a new snap ring.

b) The snap ring tapered side must face upward when installing.

- (2) Install the stop ring.  
 (3) Apply a coat of grease to the oil seal lips.  
 (4) Install the oil seal by pushing it by hand.

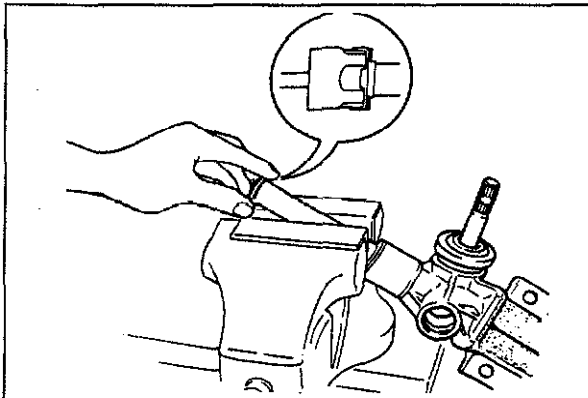

73G10X-029

8. Attach new washers to the left and right tie-rods, and then screw them onto the rack.

**Caution**

Be sure that the washers face in the correct direction.

# 10 MANUAL STEERING GEAR AND LINKAGE

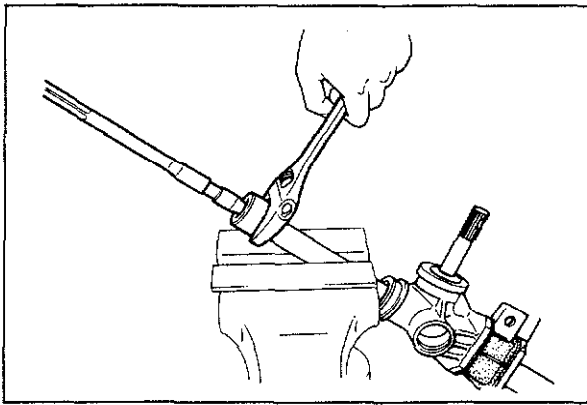

73G10X-030

9. Using a wrench, tighten the left and right tie-rods to the specified torque.

**Tightening torque: 80—100 N·m  
(8—10 m·kg, 58—72 ft·lb)**

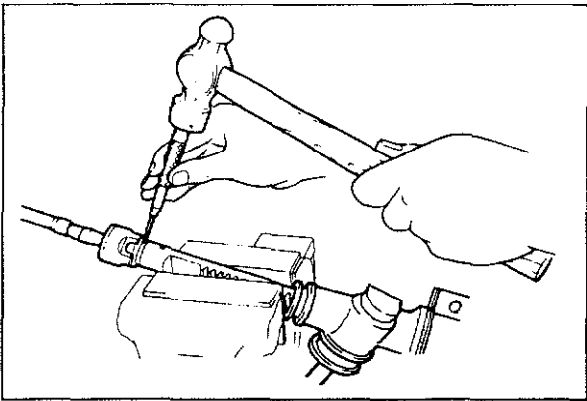

73G10X-031

10. Align the washer with the rack groove, and crimp the washer.

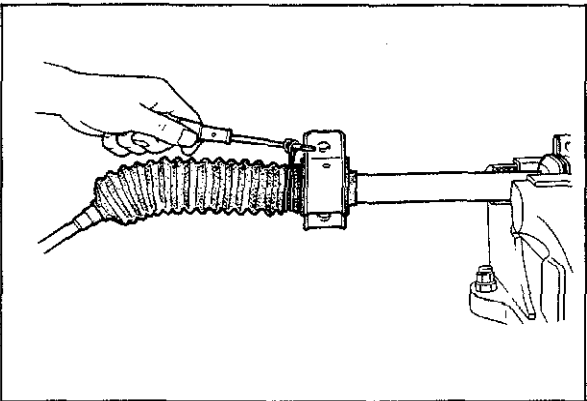

73G10X-032

11. Install the boot, and then wrap a new wire two times around it and twist it 4 or 4.5 times.

**Caution**

**Check that the boot is not twisted or dented.**

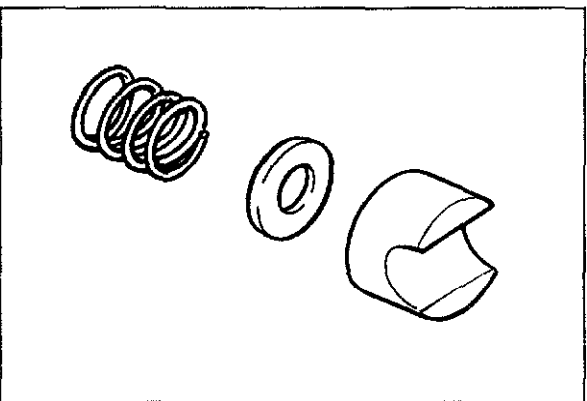

73G10X-033

12. Install the support yoke, spacer and yoke spring.

**Caution**

**Install so that the support yoke correctly contacts the rack.**

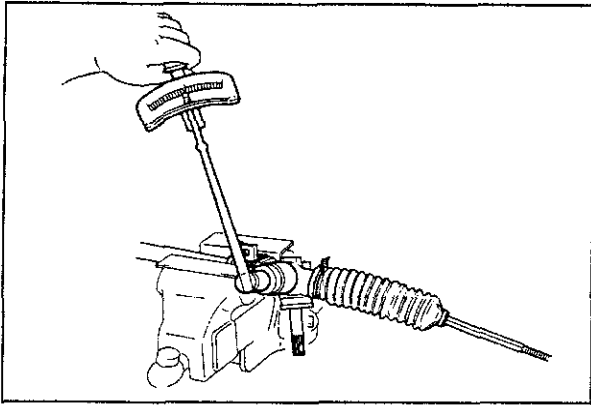

73G10X-034

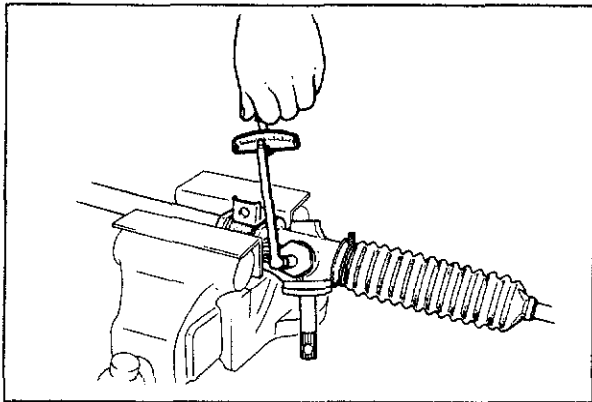

73G10X-035

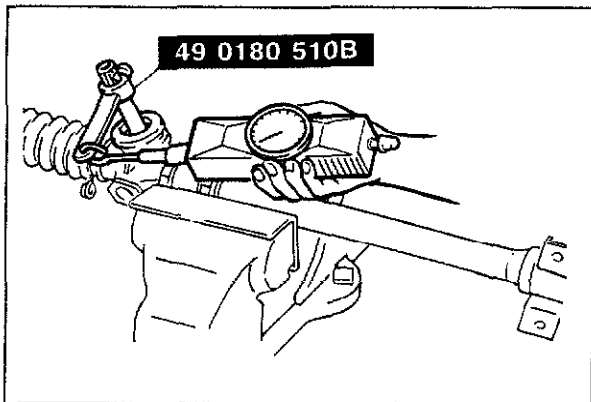

83U10X-036

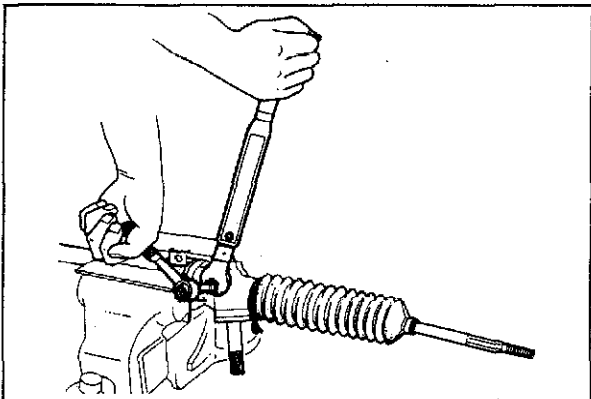

73G10X-037

13. Install the adjust cover as follows:
- (1) Apply a coat of sealant to the threads of the adjust cover.
  - (2) Install the adjust cover.

**Tightening torque:**

**39—59 N·m (4.0—6.0 m·kg, 29—43 ft·lb)**

- (3) After tightening the adjust bolt to a torque of **1 N·m (10 cm·kg, 8.7 in·lb)**, loosen it **10°—40°** from that position.

- (4) Measure the pinion torque with the **SST** and a pull-scale.

**Pinion torque:**

**Neutral position  $\pm 90^\circ$  0.9—1.3 N·m**

**(9—13 cm·kg, 7.81—11.28 in·lb)**

**Pull-scale reading: 900—1300 g**

**(31.7—45.9 oz)**

**Any other position 1.5 N·m or less**

**(15 cm·kg, 13.02 in·lb or less)**

**Pull-scale reading: 1500 g or less**

**(52.9 oz or less)**

- (5) If the pinion torque is not within the standard range, readjust the pinion torque by adjusting the adjust bolt.
- (6) Tighten the locknut and secure the adjust bolt.

**Tightening torque: 10—15 N·m**

**(1.0—1.5 m·kg, 7.2—10.8 ft·lb)**

**Caution**

**Do not allow the adjust bolt to turn with the locknut.**

# 10 MANUAL STEERING GEAR AND LINKAGE

---

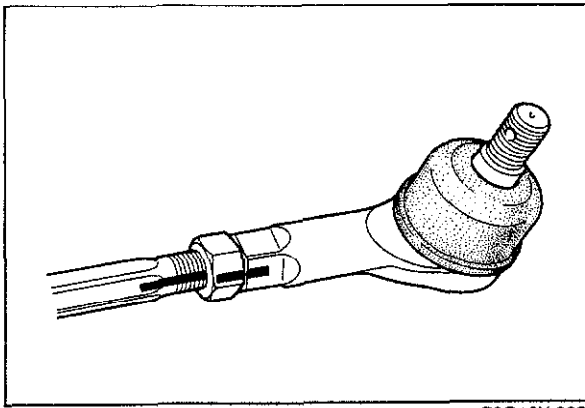

73G10X-03B

14. Install the tie-rod ends and align them with the marks made before disassembly.

## DISASSEMBLY (MANUAL STEERING, VARIABLE GEAR RATIO TYPE)

Disassemble in the numbered sequence shown in the figure.

### Note

Before disassembling, drain the gear oil and clean thoroughly.

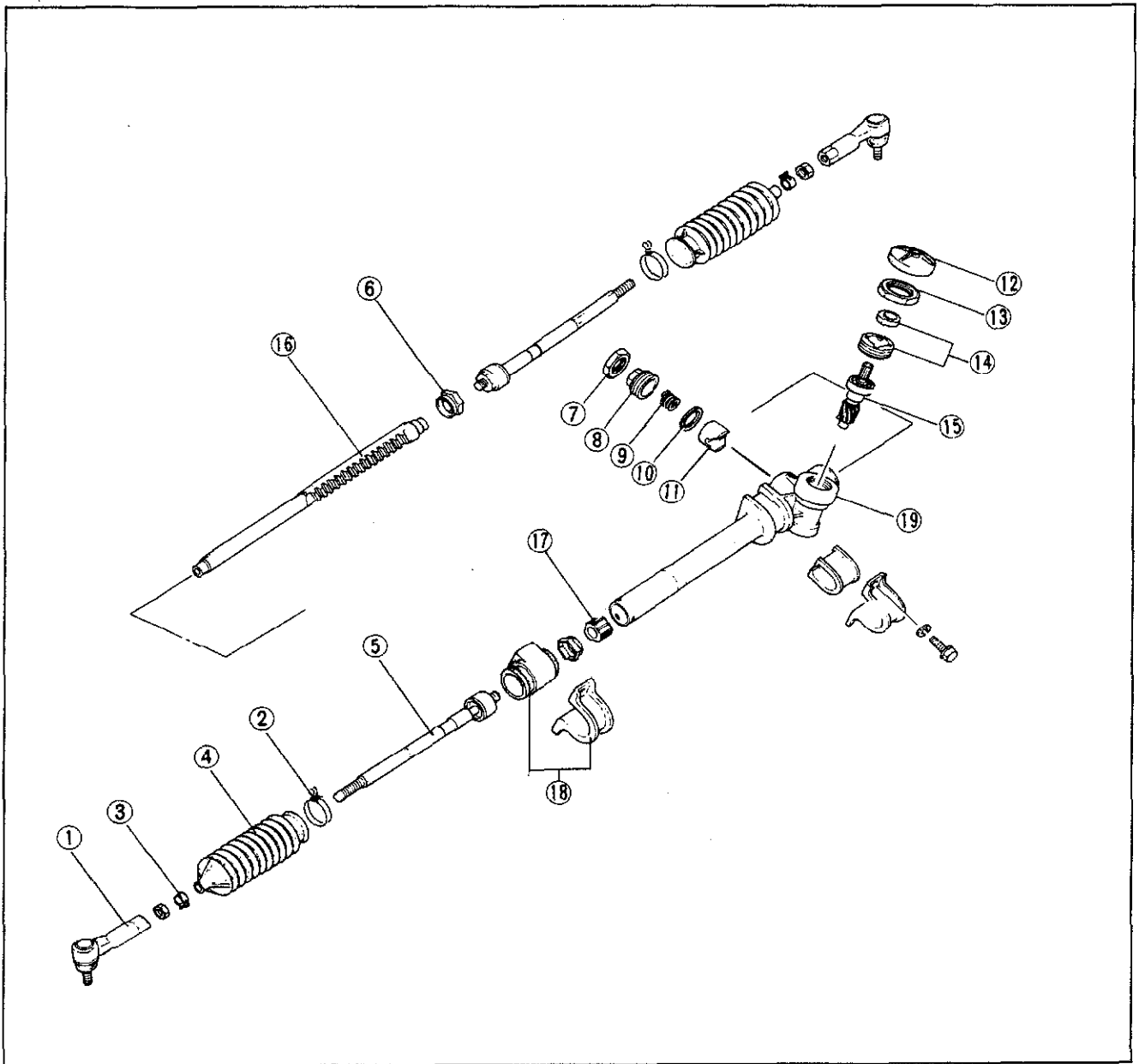

83U10X-036

1. Tie-rod ends (left/right)
2. Boot wires (left/right)
3. Boot clips (left/right)
4. Boot (left/right)
5. Tie-rod (left/right)
6. Washers (left/right)
7. Locknut

8. Adjust cover
9. Spring
10. Pressure pad plate
11. Pressure pad
12. Dust cover
13. Locknut
14. Pinion plug and oil seal

15. Bearing and pinion
16. Rack
17. Bushing
18. Mounting brackets and rubber mountings
19. Gear housing

# 10 STEERING GEAR AND LINKAGE

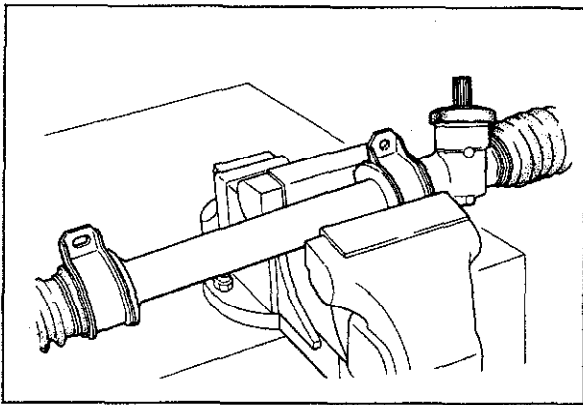

63U10X-086

## Steering gear and linkage

Secure the mounting part of the removed gear and linkage in a vise.

### Caution

Be sure to insert a soft, protective material between the part and the jaws of the vise.

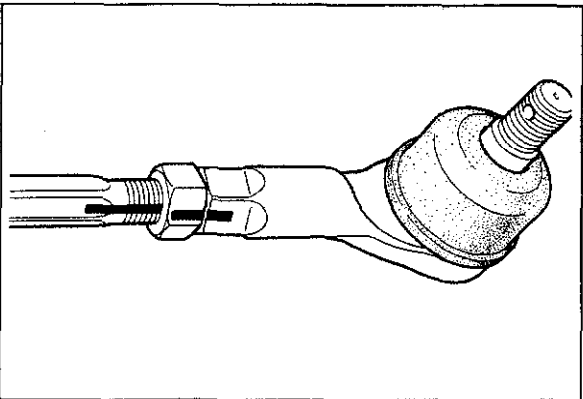

63U10X-087

## Tie-rod ends

Before removing the tie-rod ends, make a mark on the threaded part of the tie-rods to use as a guide for installation.

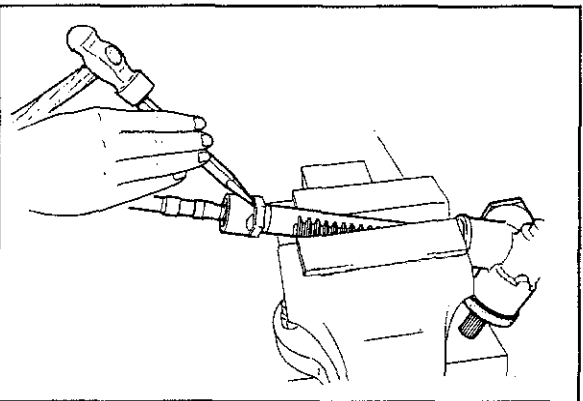

63U10X-088

## Tie-rods

1. Uncrimp the locking washer.

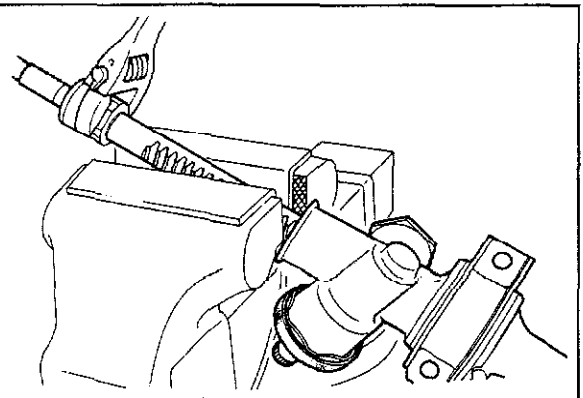

63U10X-089

2. After wrapping the rack in a rag and securing it in a vise, remove the tie rod from the rack.

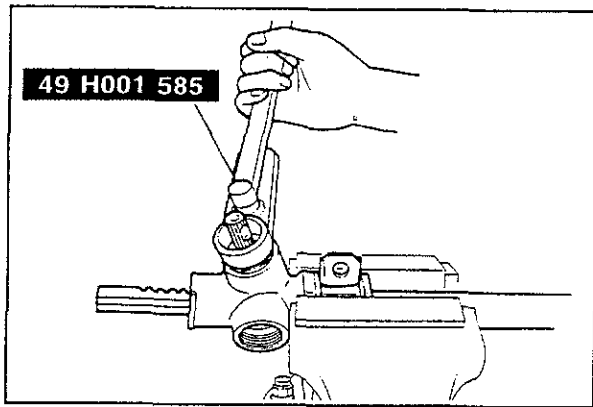

83U10X-037

### Pinion plug

The pinion plug is removed with the **SST**.

### Caution

When installing the pinion plug, apply a coat of sealant to the threads.

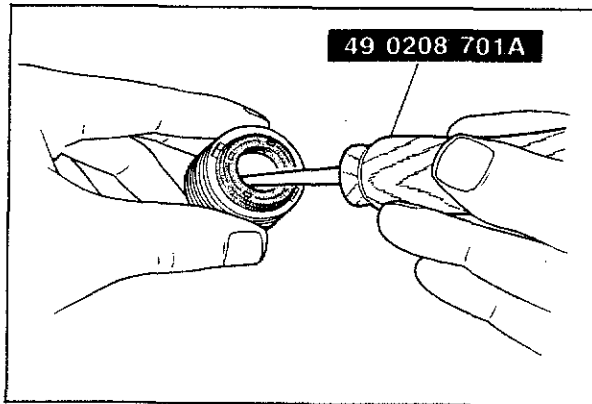

83U10X-038

### Pinion plug oil seal

Remove the oil seal from the pinion plug with the **SST**.

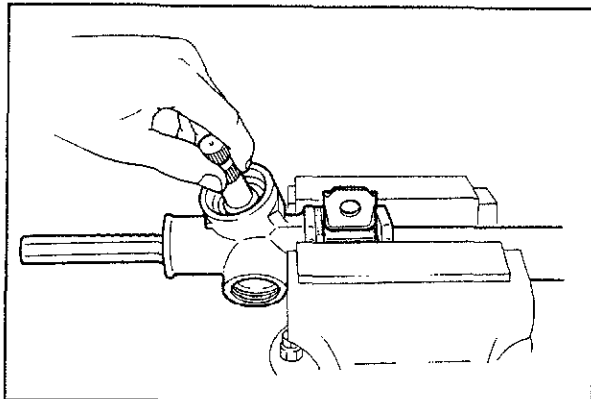

83U10X-092

### Pinion

Gently grasp the serrated part of the pinion, and pull it out.

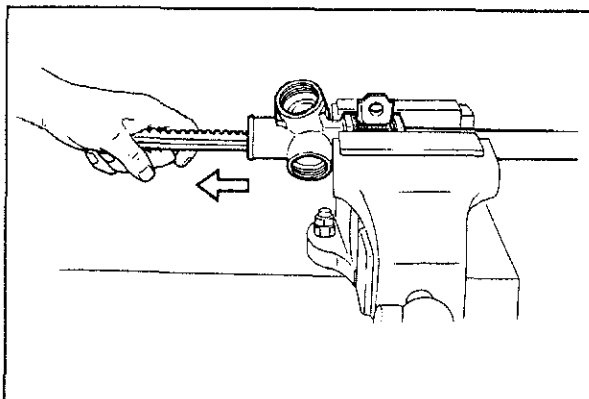

83U10X-093

### Rack

Remove the rack by taking it out in the direction indicated by the arrow.

### Caution

If the rack is taken out in the opposite direction, the inside surface of the rack bushing might be damaged by the edge of the rack gear.

# 10 STEERING GEAR AND LINKAGE

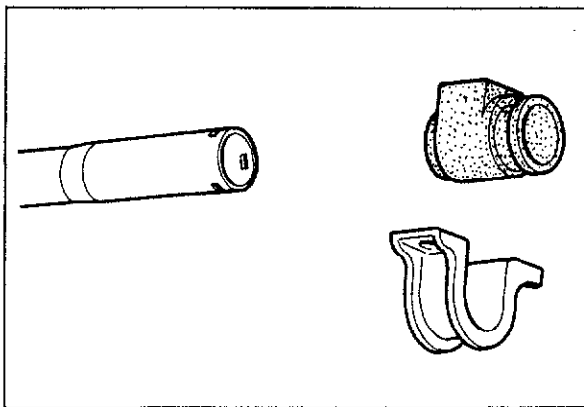

## Bushing

1. Remove the mounting rubber from the housing.

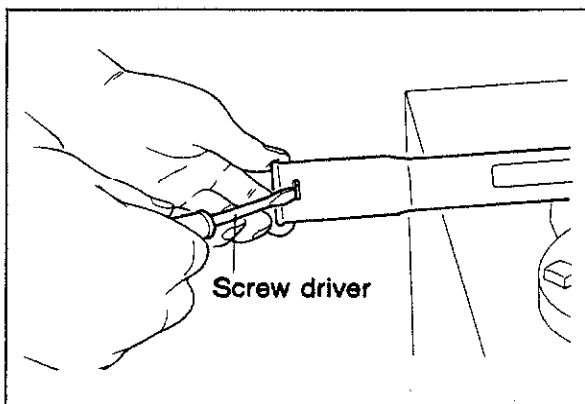

2. Unlock the bushing from the housing by pushing against each of the three lock points with a flat blade screwdriver.

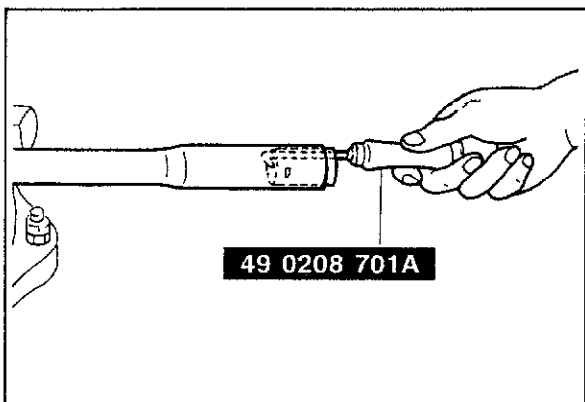

3. Remove the bushing with **SST**.

## Note

**After removing the bushing, clean the inside of the housing.**

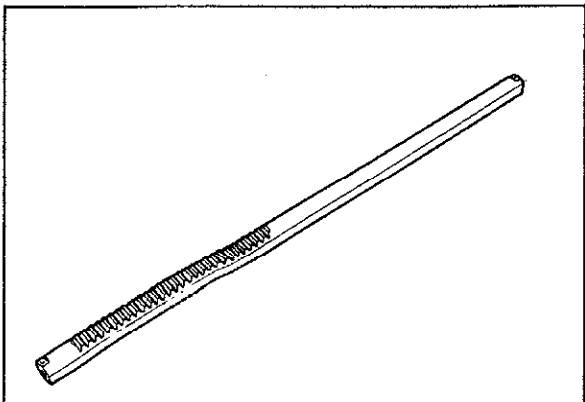

## INSPECTION

Check the following points, replace the part if a problem is found.

1. Cracking, damage, or deterioration of boots
2. Cracking, worn teeth, or damage to rack and pinion
3. Looseness, abnormal noise, or poor bearing operation inside the gear housing



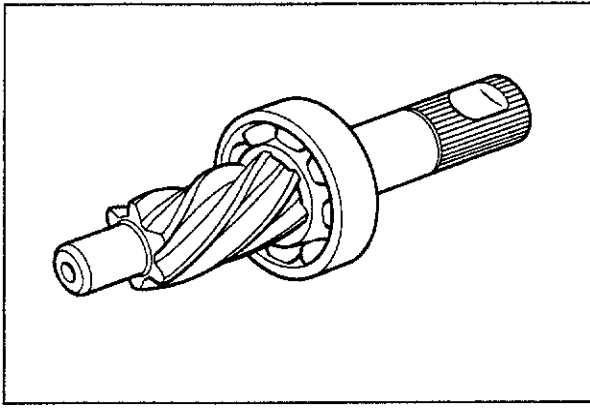

63U10X-098

4. Worn rack bushing inside the gear housing. Wear, normal noise, or rough movement of the bearing on the pinion shaft.

**Caution**

- a) If replacement is necessary, replace the entire gear housing assembly.
- b) Abnormal noise or rough movement of the bearing.
- c) If replacement is necessary, replace the entire pinion and bearing assembly.

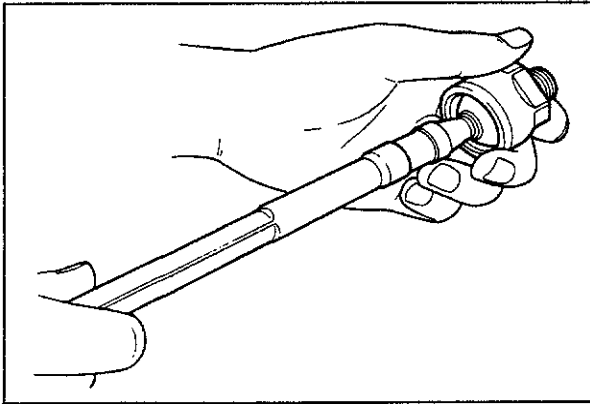

63U10X-099

5. Wear of sliding surface of pressure pad which contacts rack
6. Cracking or deformation of gear housing
7. Looseness or lack of smoothness in tie-rod ball-joint operation
8. Bent tie-rods or tie-rod ends
9. Damage to tie-rods or tie-rod ends.

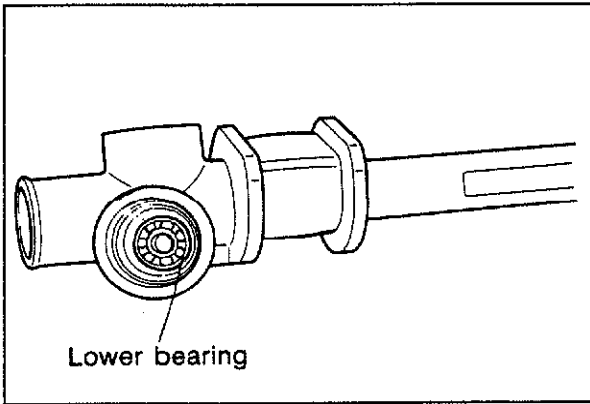

63U10X-100

**ASSEMBLY**

Assemble in the order described below.

1. Press in the lower bearing.

**Caution**

Before pressing it in, fill the bearing with grease (lithium base, NLGI No. 2).

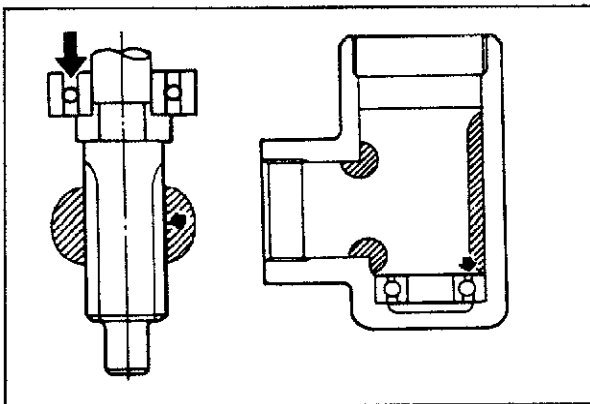

63U10X-101

2. Fill or coat with grease.  
Before assembly, coat (or fill) the following parts with grease (lithium base, NLGI No. 2):
  - (1) Pinion bearing and teeth
  - (2) Inside the gear housing

# 10 STEERING GEAR AND LINKAGE

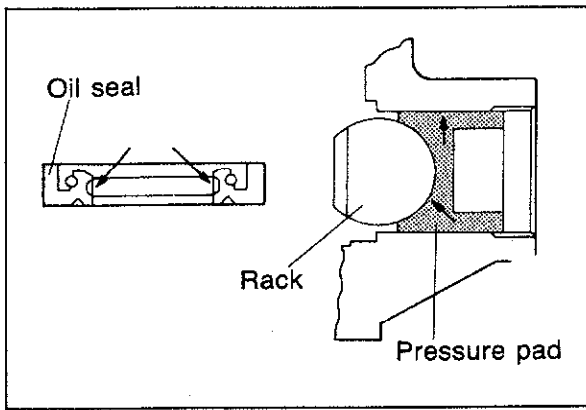

63U10X-102

- (3) Oil seal lip
- (4) Pressure pad sliding part and rear surface

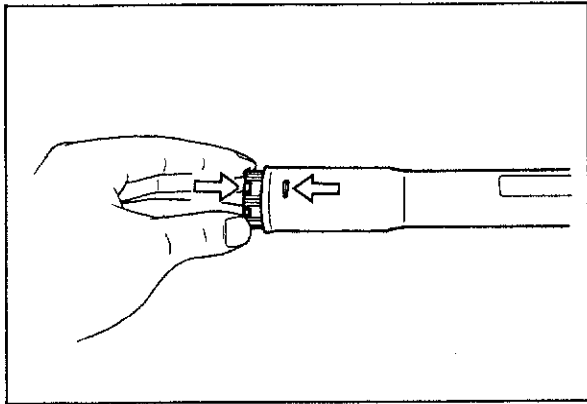

63U10X-103

- 3. Installation of rack bushing.  
Install the rack bushing to the rack housing so that the convex part of the rack bushing lines up with the slit of the rack housing. Align the three lock points and tap in with the old bushing and a piece of wood.

### Note

**Apply grease (lithium base, NLGI No. 2) to the inside of the bushing.**

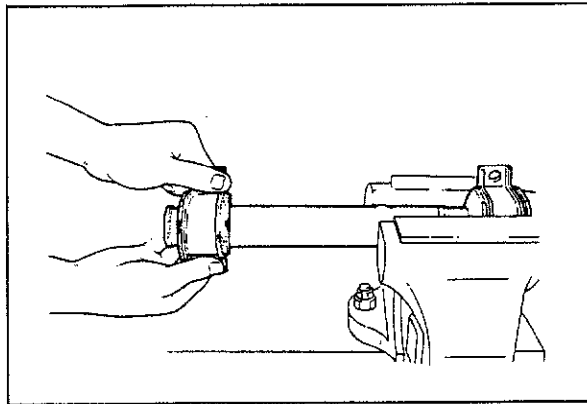

63U10X-104

- 4. Push the mounting rubber on until it just contacts the end of the housing.

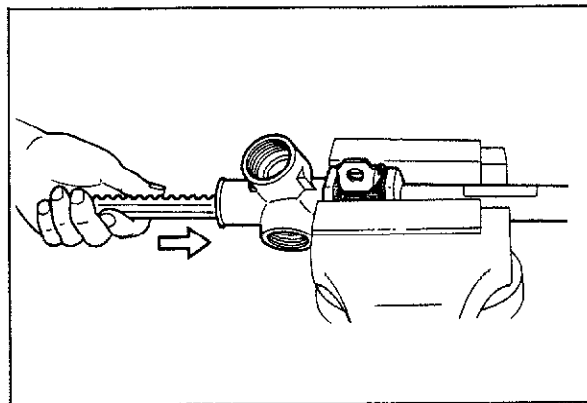

63U10X-105

- 5. Carefully install the rack in the direction of the arrow.

### Caution

**If the rack is installed from the opposite direction, the inner surface of the rack bushing might be damaged by the edge of the rack gear.**

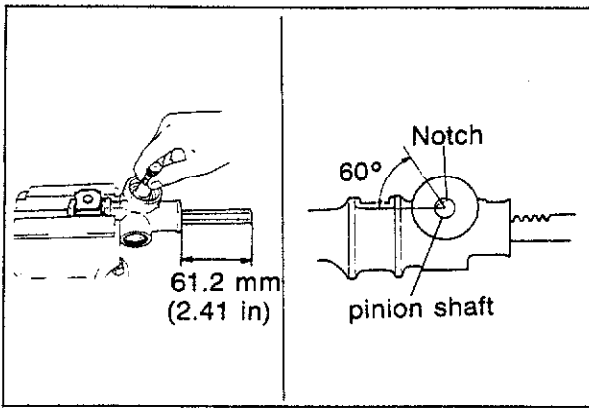

63U10X-106

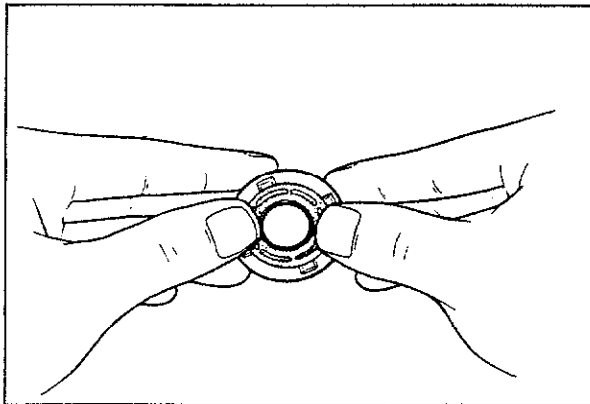

63U10X-107

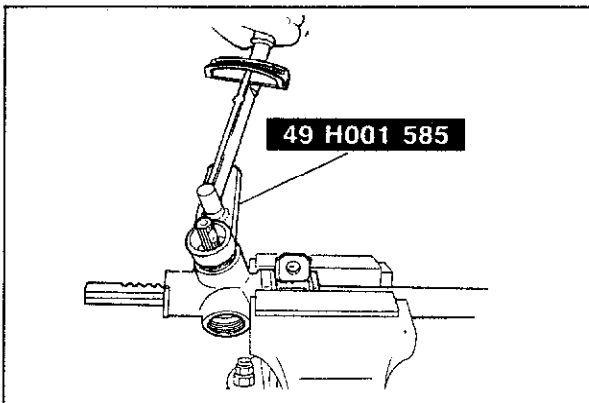

83U10X-040

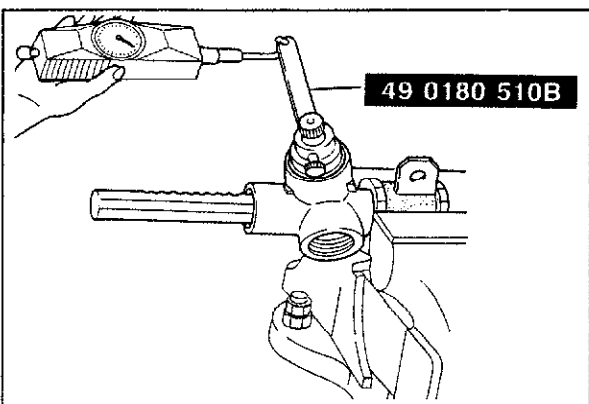

83U10X-041

6. Install the pinion shaft with the notch on the serration positioned as shown in the figure when the rack is positioned at the center of the rack housing.

7. Install the upper bearing.

8. Push the oil seal in to the pinion plug, and then install the pinion plug with the oil seal onto the pinion shaft.

9. Install the pinion plug.

10. Adjust the pinion torque to be 0.2 N·m (2 cm·kg, 1.74 in·lb) by adjusting the pinion plug. Check with the **SST**.

11. Install the lock nut with the **SST**.

**Tightening torque: 70—90 N·m**  
(7.0—9.0 m·kg, 50.6—65.1 ft·lb)

12. Recheck the pinion torque. If it is not correct readjust as in (10).

**Tightening torque: 0.15—0.25 N·m**  
(1.5—2.5 cm·kg, 1.3—2.2 in·lb)

### Caution

a) Before measuring the torque, rotate the pinion to the left and right so that the bearing is seated.

b) If the **SST** and a spring balance are used for the measurement, the reading of the pull scale should be about 150—250 g (5.3—8.8 oz).

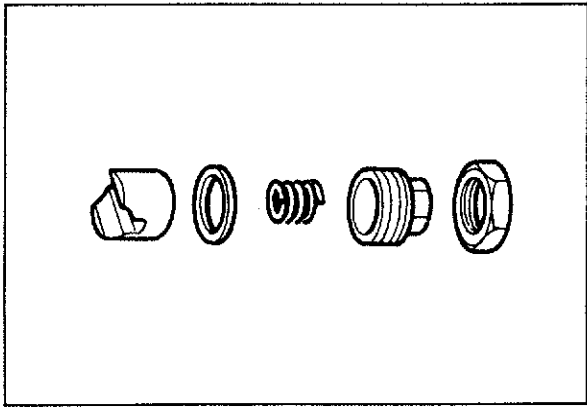

13. Install the pressure pad, spring, adjustment cover and lock nut.

**Caution**

- a) Install so that the pressure pad correctly contacts the rack.
- b) Apply a coat of sealant to the threads of the adjustment cover.

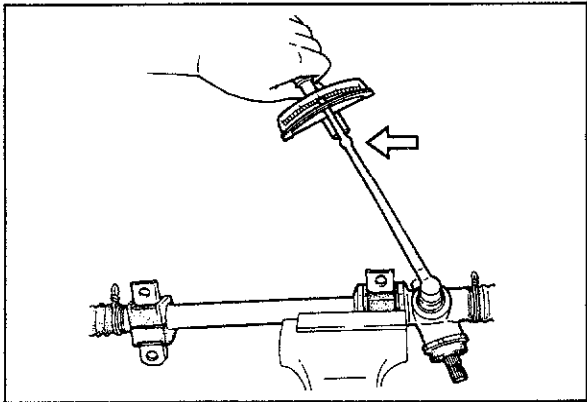

14. After tightening the adjustment cover to a torque of **5 N·m (50 cm·kg, 7.2 ft·lb)** loosen it about **15°** from that position. And then tighten the lock nut securely.

**Lock nut tightening torque: 60—75 N·m (6.0—7.5 m·kg, 43.4—54.2 ft·lb)**

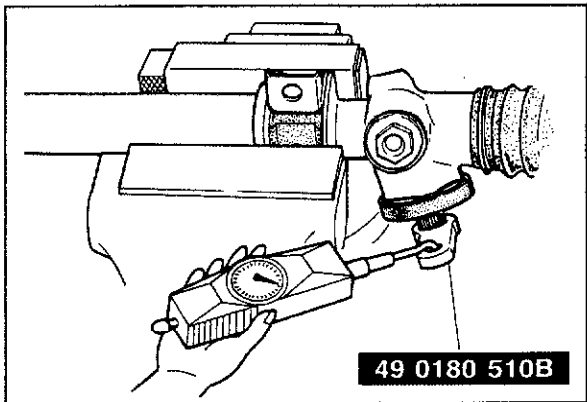

15. Measure the pinion torque.  
Measure the pinion torque with the **SST**.

**Pinion torque:**

**Neutral position  $\pm 90^\circ$  1.0—1.4 N·m (10—14 cm·kg, 0.87—1.21 in·lb)**  
**[Pull scale reading: 1,000—1,400 g (35.3—49.4 oz)]**  
**Any other position 2.3 N·m or less (23 cm·kg, 19.96 in·lb or less)**  
**[Pull scale reading: 2,300 g or less (81.13 oz or less)]**

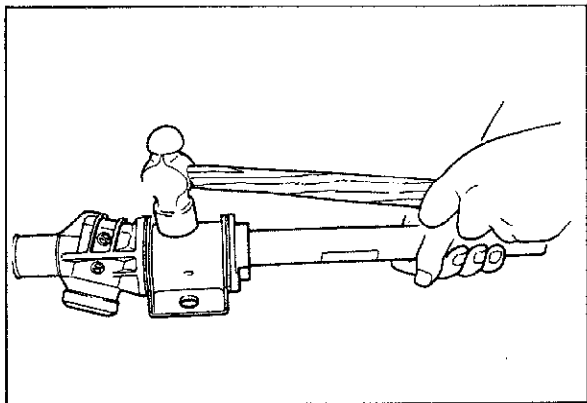

16. Attach the rubber mount to the column.

**Caution**

- a) Be sure that the direction of installation and the alignment are correct.
- b) If the rubber mount is difficult to install, apply soapy water to the inside of the mount.

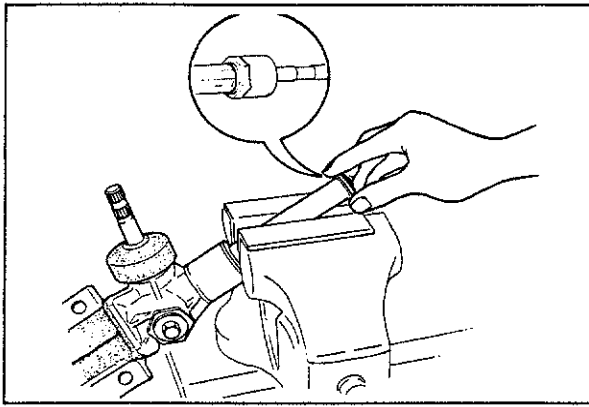

63U10X-115

17. Attach new washers to the left and right tie-rods, and then screw them onto the rack.

**Caution**

**Be sure that the washers face in the proper direction.**

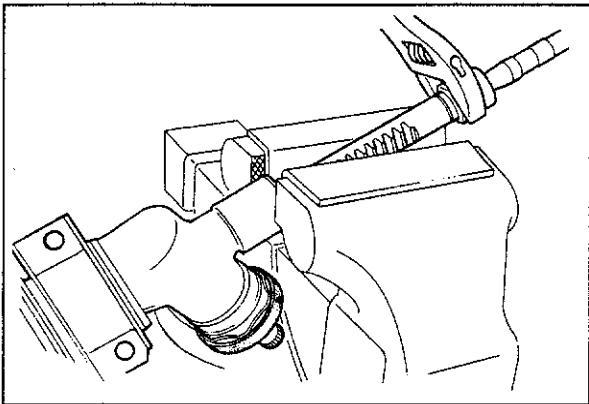

63U10X-116

18. Using a wrench, tighten the left and right tie-rods to the specified torque.

**Tightening torque: 80—100 N·m  
(8—10 m·kg, 58—72 ft·lb)**

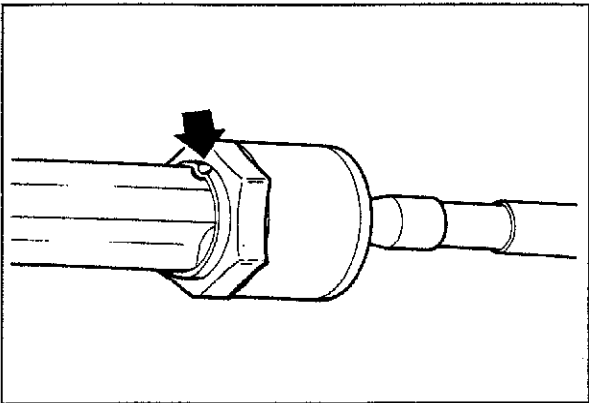

63U10X-117

19. Align the washer with the rack groove, and then crimp the washer.

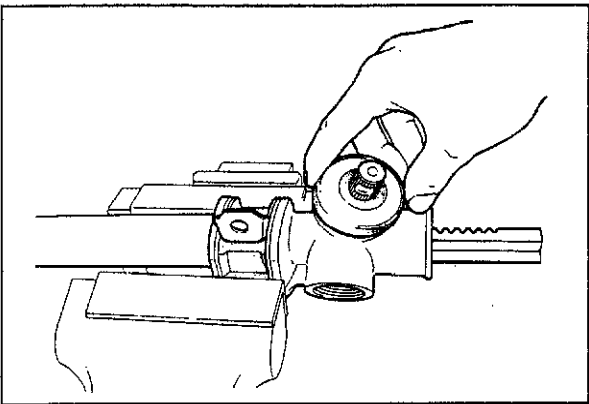

63U10X-118

20. Insert the dust cover to the pinion groove.

# 10 STEERING GEAR AND LINKAGE

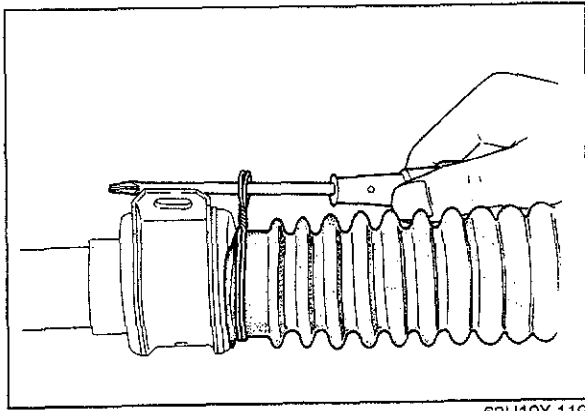

21. Install the new boot, and then wrap a new wire two times around it and twist it 4 or 4.5 times.

**Caution**

**Be sure that the boot is not twisted or dented.**

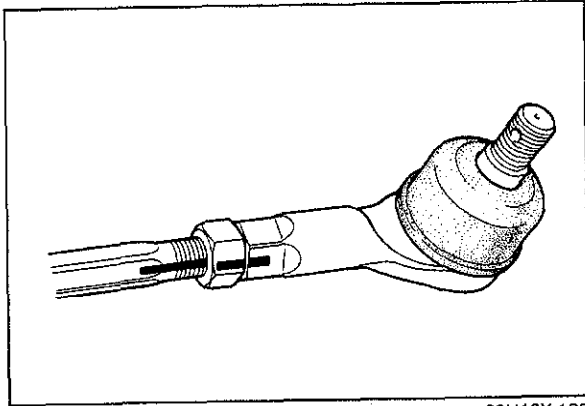

22. Install the tie-rod ends and align them with the marks made before disassembly.

## DISASSEMBLY (POWER STEERING)

Disassemble in the sequence shown in the figure.

### Caution

- a) In order to prevent the entrance of dirt, all disassembly and assembly should be done in a clean area.
- b) Before disassembly, plug the openings of all pipe installation fittings, and then remove all external grease and dirt from the gear and linkage.

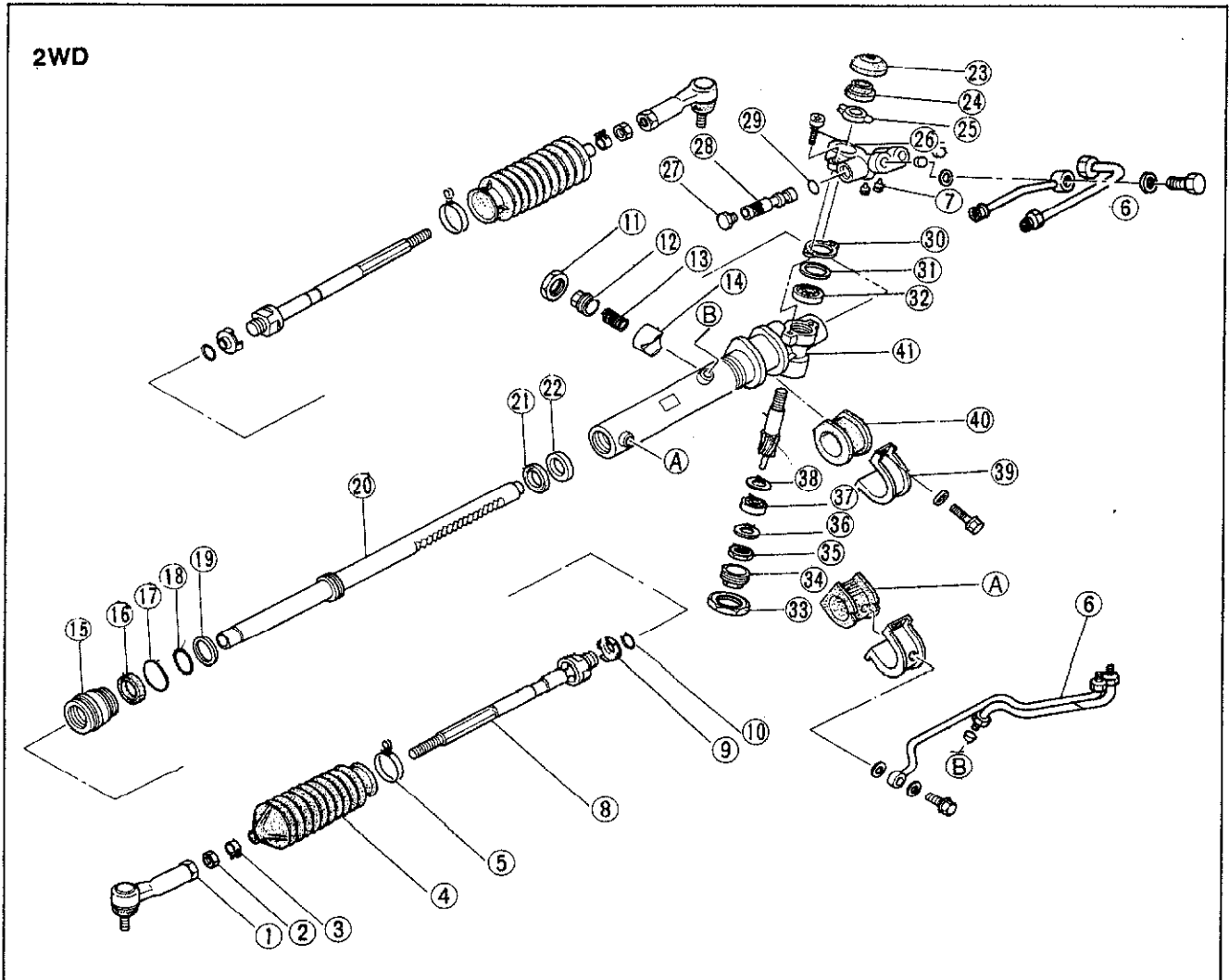

83U10X-043

- |                          |                        |                           |
|--------------------------|------------------------|---------------------------|
| 1. Tie-rod end           | 15. Outer box          | 29. "O" ring              |
| 2. Tie-rod end locknut   | 16. Oil seal           | 30. Gasket                |
| 3. Boot band             | 17. "O" ring           | 31. Spacer                |
| 4. Boot                  | 18. "O" ring           | 32. Bearing               |
| 5. Boot wires            | 19. Seal ring          | 33. Housing cover locknut |
| 6. Oil pipes             | 20. Rack               | 34. Housing cover         |
| 7. Seal                  | 21. Oil seal           | 35. Lower bearing locknut |
| 8. Tie-rod               | 22. Inner guide        | 36. Thrust washer         |
| 9. Washer                | 23. Dust cover         | 37. Lower bearing         |
| 10. Damper ring          | 24. Oil seal           | 38. Pinion shaft          |
| 11. Adjust cover locknut | 25. Lever              | 39. Mounting bracket      |
| 12. Adjust cover         | 26. Valve case         | 40. Mounting rubber       |
| 13. Spring               | 27. Control valve bolt | 41. Gear housing          |
| 14. Rack support         | 28. Control valve      |                           |

# 10 STEERING GEAR AND LINKAGE

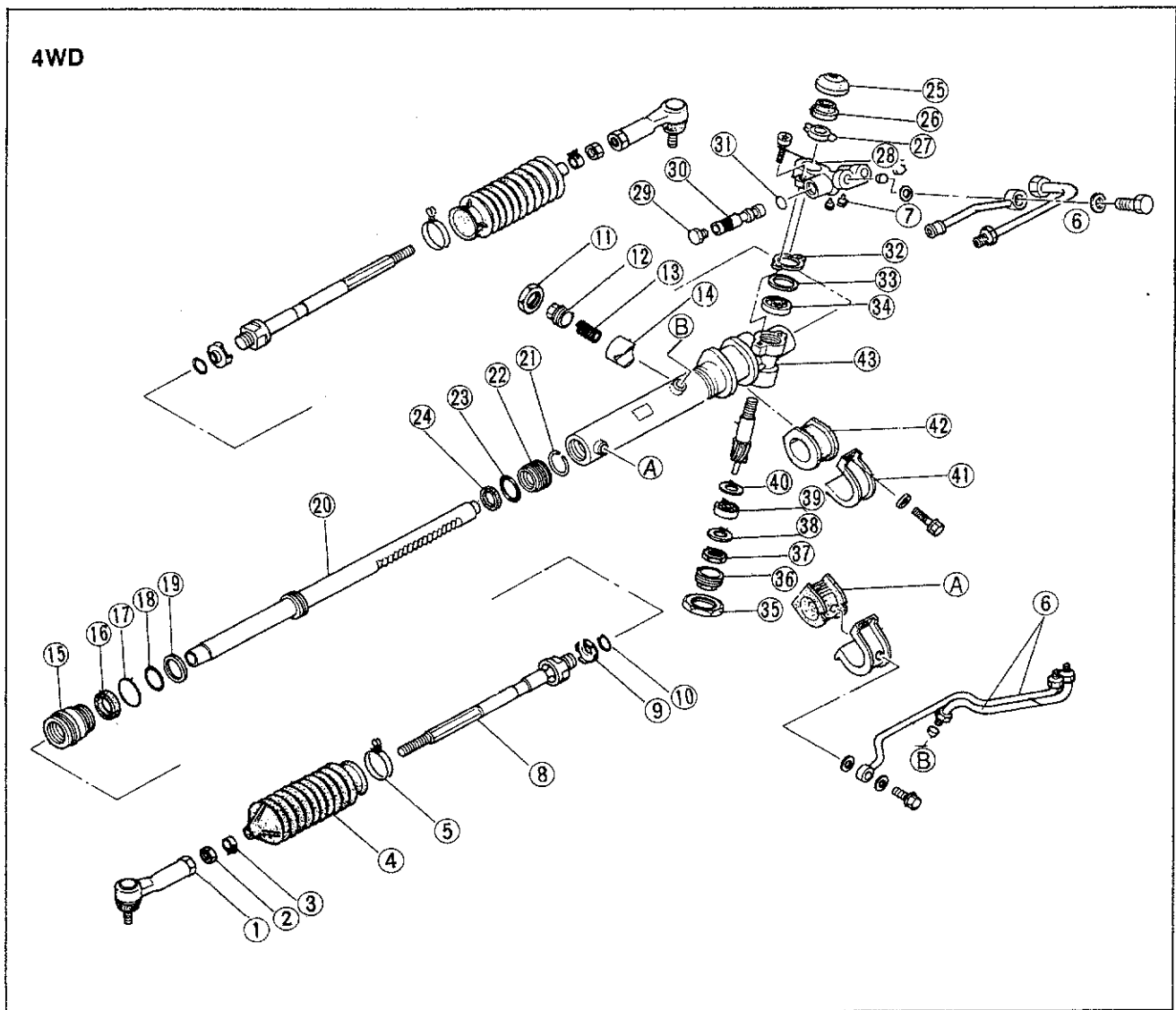

83U10X-044

- |                          |                        |                           |
|--------------------------|------------------------|---------------------------|
| 1. Tie-rod end           | 16. Oil seal           | 31. "O" ring              |
| 2. Tie-rod end locknut   | 17. "O" ring           | 32. Gasket                |
| 3. Boot ban              | 18. "O" ring           | 33. Spacer                |
| 4. Boot                  | 19. Seal ring          | 34. Bearing               |
| 5. Boot wires            | 20. Rack               | 35. Housing cover locknut |
| 6. Oil pipes             | 21. Snap ring          | 36. Housing cover         |
| 7. Seal                  | 22. Inner guide        | 37. Lower bearing locknut |
| 8. Tie-rod               | 23. "O" ring           | 38. Thrust washer         |
| 9. Washer                | 24. Oil seal           | 39. Lower bearing         |
| 10. Damper ring          | 25. Dust cover         | 40. Pinion shaft          |
| 11. Adjust cover locknut | 26. Oil seal           | 41. Mounting bracket      |
| 12. Adjust cover         | 27. Lever              | 42. Mounting rubber       |
| 13. Spring               | 28. Valve case         | 43. Gear housing          |
| 14. Rack support         | 29. Control valve bolt |                           |
| 15. Outer box            | 30. Control valve      |                           |



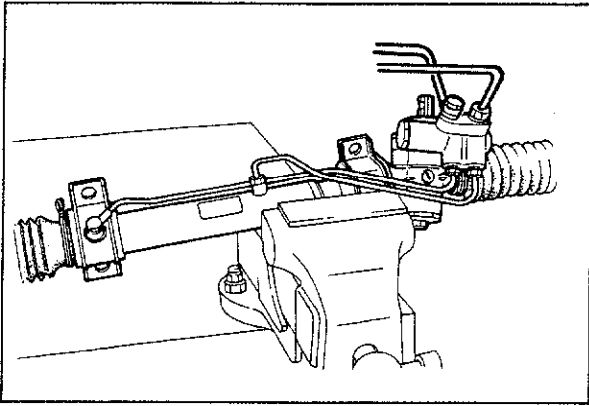

63U10X-122

## Steering gear and linkage

Secure the mount part of the removed gear and linkage in a vise.

### Caution

Be sure to insert protective material (such as copper plates) between the part and the jaws of the vise.

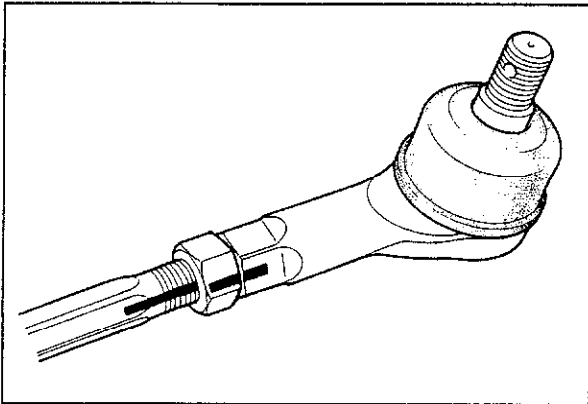

63U10X-123

## Tie-rod ends

Before removing the tie-rod ends, make a mark on the threaded parts as a guide for installation.

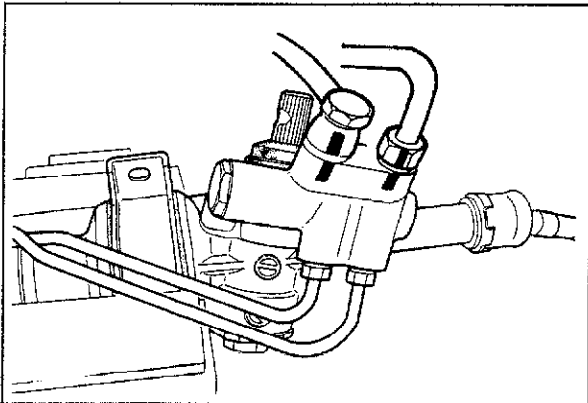

63U10X-124

## Oil pipe

1. Make matching marks on the pressure pipe and the return pipe and the valve case, and then remove the pipes.

### Note

The matching marks help make sure the pipes are reinstalled in the correct position.

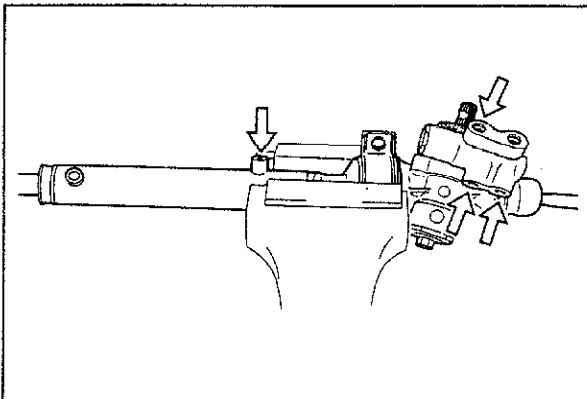

83U10X-045

2. Remove the washers in the pressure pipe and the return pipe with the **SST**.

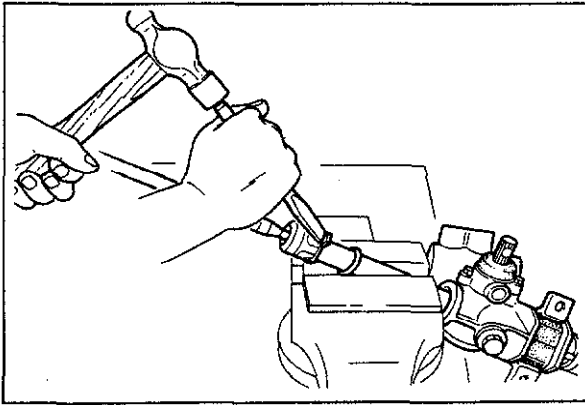

83U10X-046

## Tie-rods

1. Slide the damper ring toward the valve housing.
2. Un-crimp the washer as shown in the figure.

### Caution

**Do not damage the tie-rod or rack.**

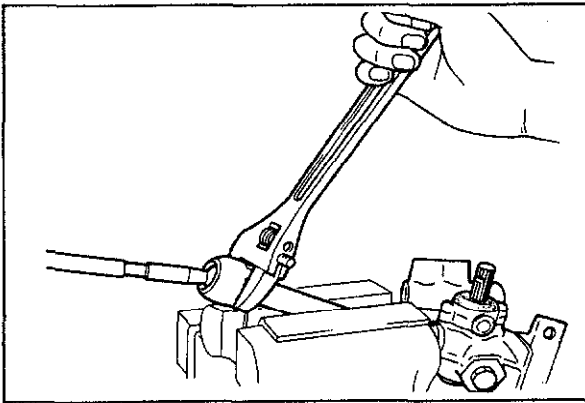

63U10X-127

3. Remove the tie-rod from the rack.

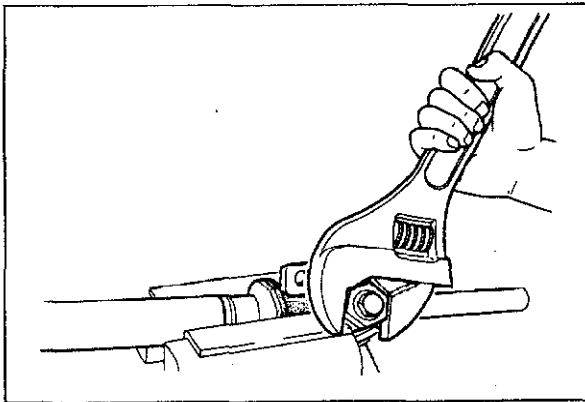

63U10X-128

## Lock nut and adjust cover

Loosen the lock nut and remove the adjusting cover, the spring and the pressure pad.

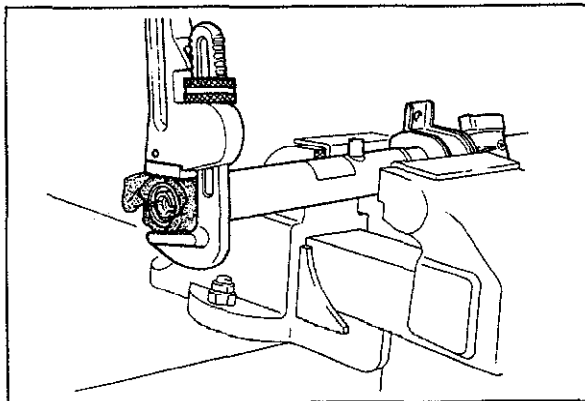

63U10X-129

## Outer box

Protect the outer box with cloth, and then remove the outer box with a pipe wrench.

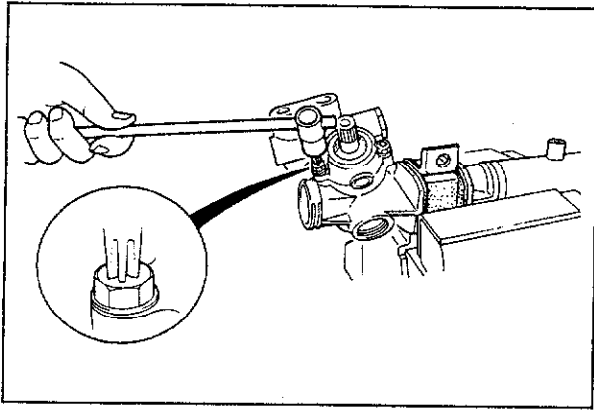

63U10X-130

### Valve case assembly

Remove the valve case assembly with a torx driver.

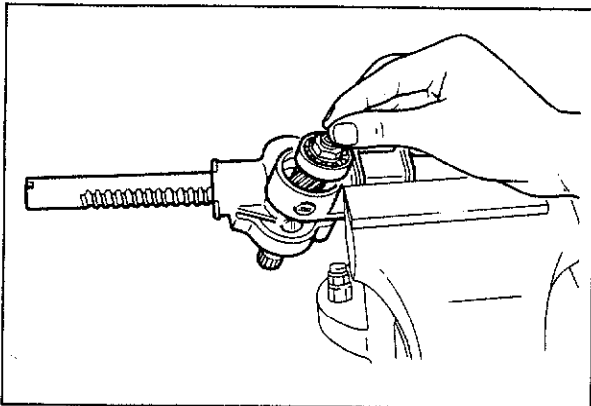

63U10X-131

### Pinion shaft assembly

Pull the pinion shaft assembly out from the lower bearing side.

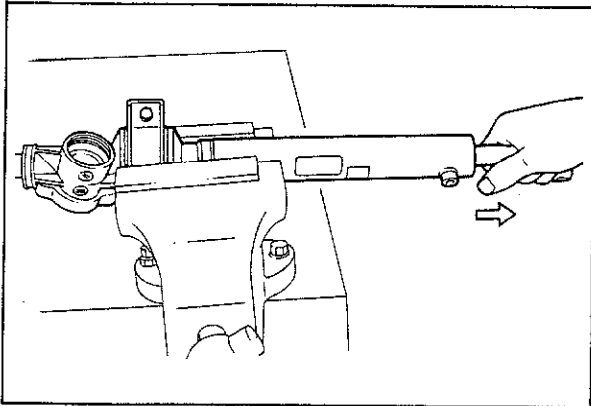

63U10X-132

### Rack

Remove the rack by taking it out in the direction indicated by the arrow.

### Caution

If the rack is taken out in the opposite direction, the inside surface of the rack bushing might be damaged by the edge of the rack gear.

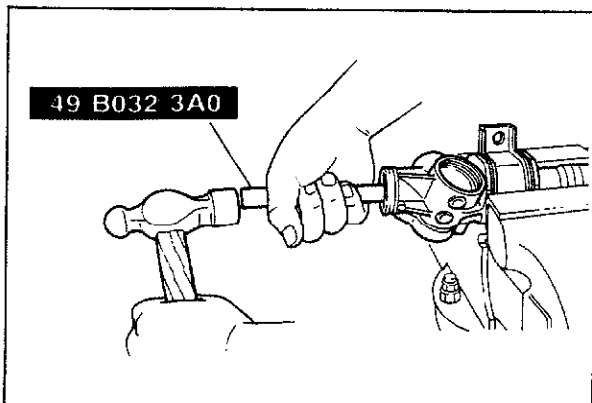

83U10X-047

### Inner guide

Remove the inner guide and the oil seal from the rack housing with the SST.

### Caution

Do not damage the inner guide or the rack housing.

# 10 STEERING GEAR AND LINKAGE

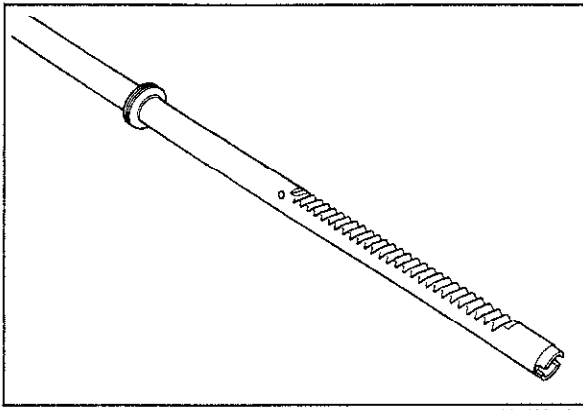

63U10X-134

## INSPECTION

Check the following points, replace the part if a problem is found.

1. Cracking, damage, or deterioration of boots
2. Cracking, worn teeth, or damage of rack and pinion
3. Looseness, abnormal noise, or poor operation of bearings.

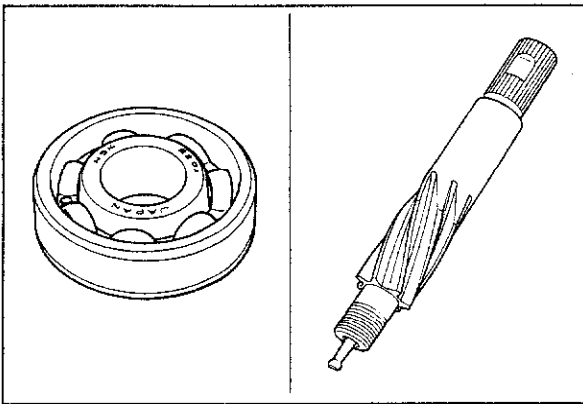

63U10X-135

4. Worn rack bushing inside the gear housing

## Caution

a) If replacement is necessary, replace the entire gear housing assembly.

b) If replacement of the pinion bearing is necessary, replace the pinion and bearing as an assembly.

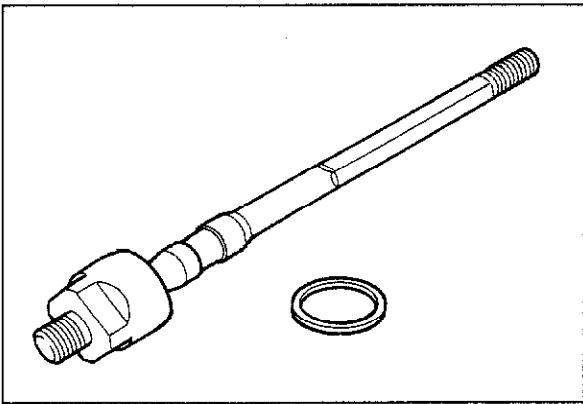

63U10X-136

5. Wear of sliding surface of pressure pad.
6. Cracking or deformation of gear housing
7. Looseness or lack of smoothness in tie-rod ball-joint operation
8. Bent tie-rods or tie-rod ends
9. Damage to tie-rods or tie-rod ends.

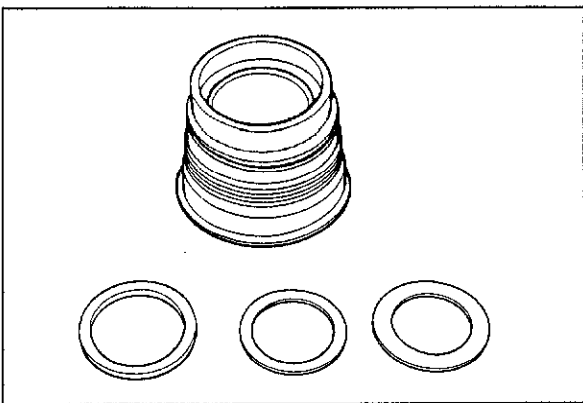

63U10X-137

10. Check the bushing of the outer box for wear.

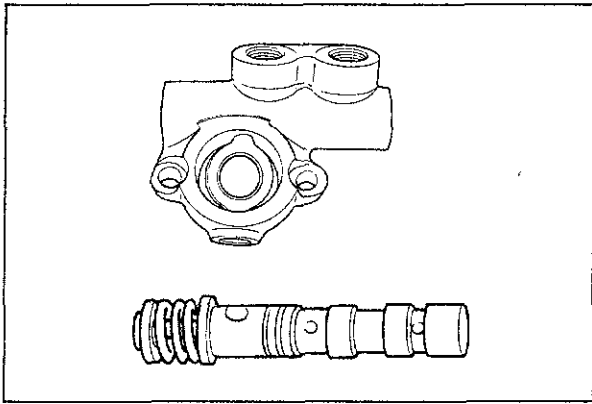

63U10X-138

11. Check the lever for wear or damage.
12. Check the spherical face of the lever and the collar for wear and damage.
13. Check the control valve for oil leakage.

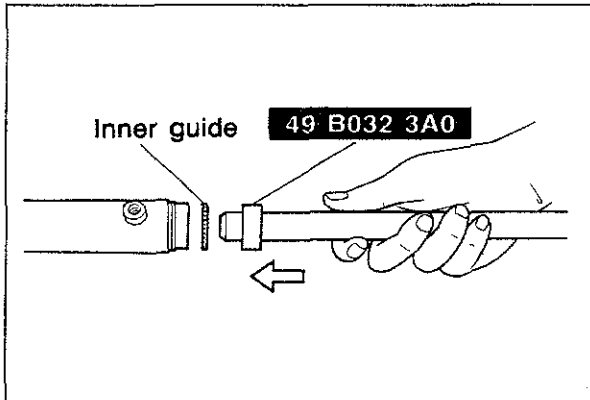

83U10X-048

## ASSEMBLY

Assemble in the following order.

1. Install the inner guide in the following order.

2WD:

- (1) Apply A.T.F. to the inner guide.
- (2) Push the oil seal and the inner guide in to the rack housing with the **SST** as far as they will go.

### Caution

**Do not damage the inner surface of the rack housing.**

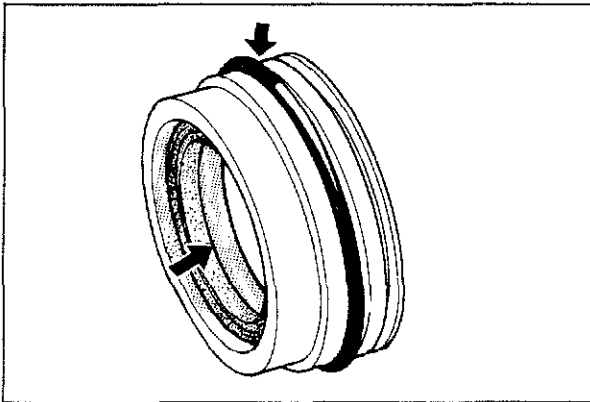

83U10X-049

4WD:

- (1) Install the oil seal, "O" ring, snap ring to the inner guide.
- (2) Coat the oil seal and the "O" ring with A.T.F..

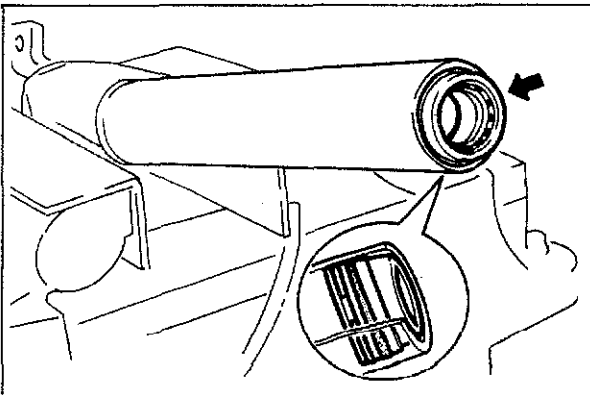

83U10X-050

- (3) Push the inner guide assembly into the threaded end of the rack housing by hand.

# 10 STEERING GEAR AND LINKAGE

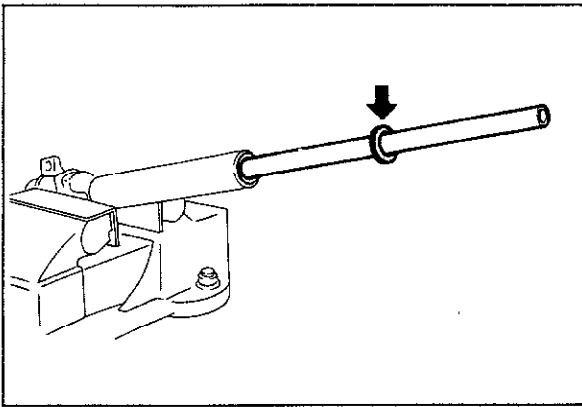

83U10X-051

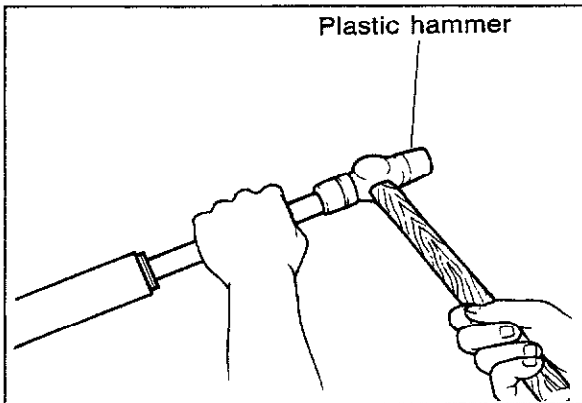

83U10X-052

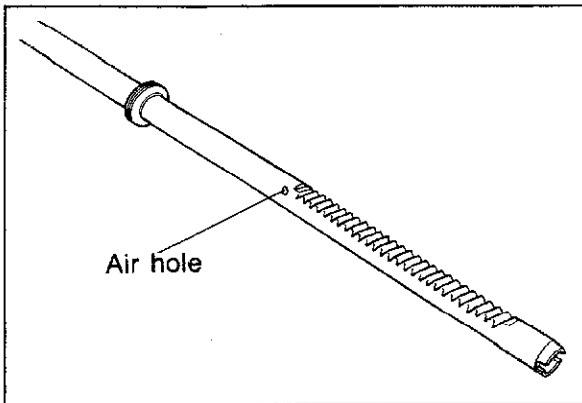

63U10X-140

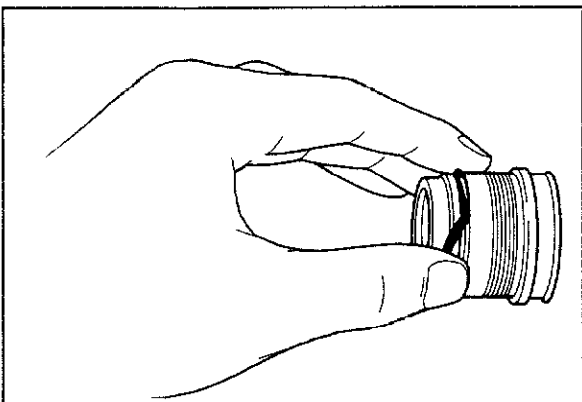

83U10X-053

(4) Slide the rack into the housing until the ring indicated by the arrow touches the inner guide.

(5) Push the inner guide into position in the housing by tapping on the rack end with a plastic hammer as far as it will go.

2. Apply grease to the rack teeth. Cover the rack teeth with vinyl to protect the seals and install the rack.

### Caution

**Do not plug the air hole of the rack with grease. Remove the vinyl after installing the rack.**

3. Install the seal ring, O-rings and oil seal to the outer box.

### Note

**Coat the seals and O-rings with ATF**

4. Install the outer box in the rack housing.

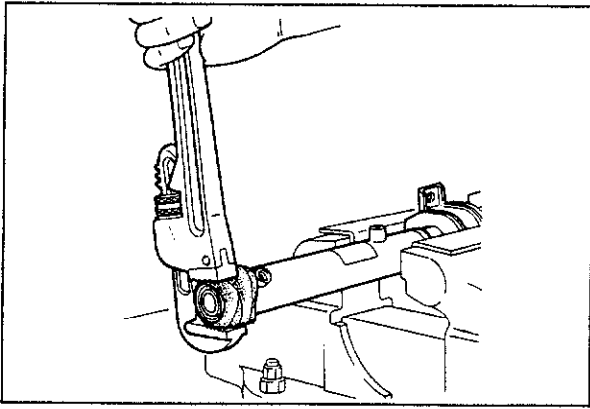

83U10X-054

5. Protect the outer box with cloth, and then tighten the outer box to the rack housing using a pipe wrench.

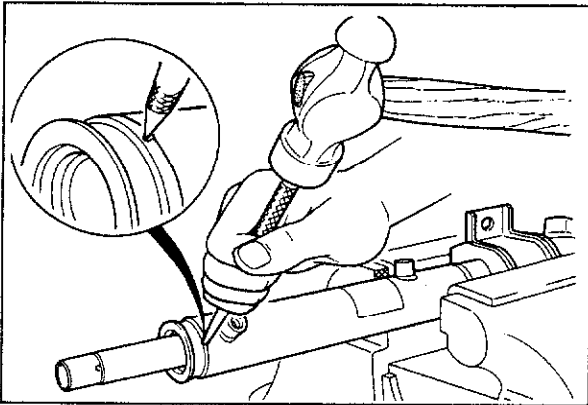

83U10X-055

6. Stake the outer box to the rack housing by using a punch.

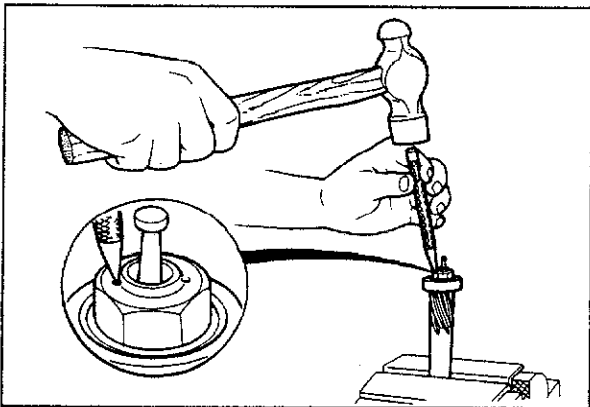

83U10X-056

7. Install the lower bearing on the pinion shaft, fit the lower bearing by tightening the nut and then stake the nut to the pinion shaft.

**Tightening torque: 40—50 N·m  
(4—5 m·kg, 28.9—36.2 ft·lb)**

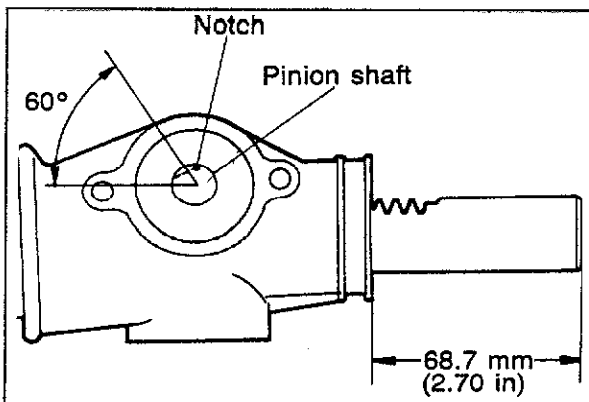

83U10X-057

8. Install the pinion shaft with the notch on the serration positioned as shown in the figure when the rack is positioned at the center of the rack housing.

# 10 STEERING GEAR AND LINKAGE

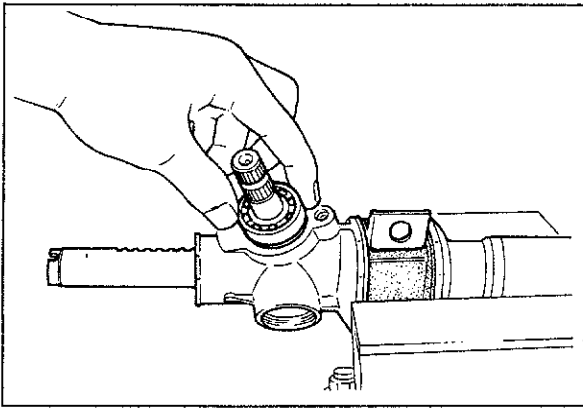

83U10X-058

9. Apply grease to the pinion and upper bearing and then install them.
10. Torque the housing cover, then loosen it 10°—20°.

**Tighten torque 5—9 N·m**  
**(50—90 cm·kg, 4.3—7.8 in·lb)**

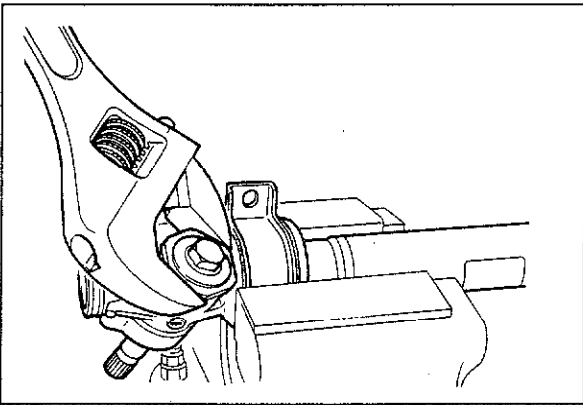

83U10X-059

11. Lock the housing cover by tightening the lock nut.

**Tightening torque: 40—50 N·m**  
**(4—5 m·kg, 28.9—36.2 ft·lb)**

12. Install the adjustment cover to the gear housing and tighten the adjustment cover, then loosen the cover by 45°.

**Tightening torque: 4.5—5.5 N·m**  
**(45—55 cm·kg, 39.1—47.7 in·lb)**

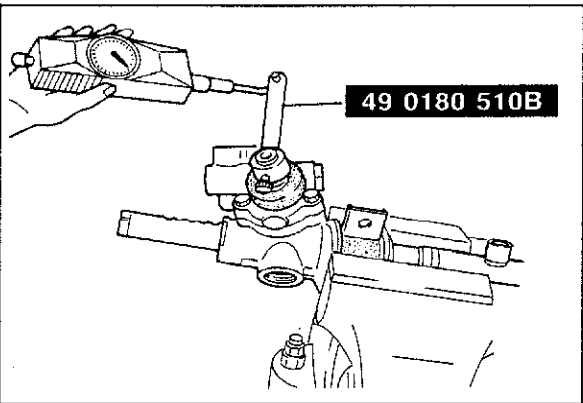

83U10X-060

13. Measure the pinion torque using the **SST**.

**Standard pinion torque:**  
**0.6—1.5 N·m (6—15 cm·kg, 0.52—1.3 in·lb)**  
**Pull scale: 600—1,500 g (21.2—53.0 oz)**

14. If the pinion torque is not within the standard range, readjust the pinion torque by adjusting the cover.

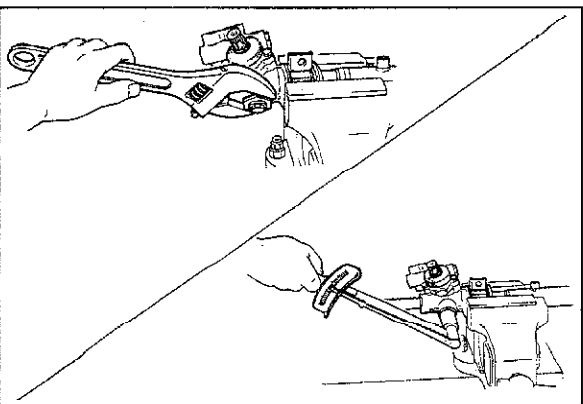

83U10X-061

15. Lock the cover by tightening the lock nut.



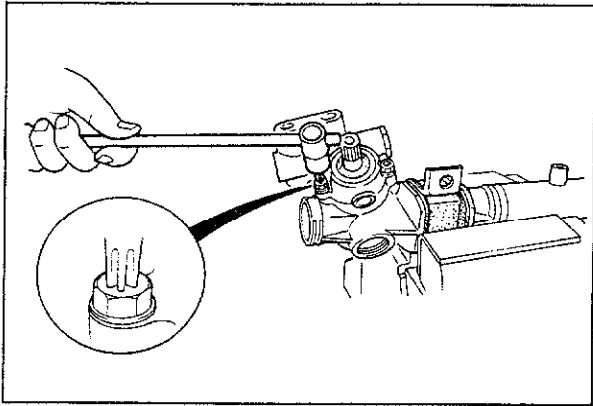

83U10X-062

16. Install the valve case to the gear housing by using a torx driver.

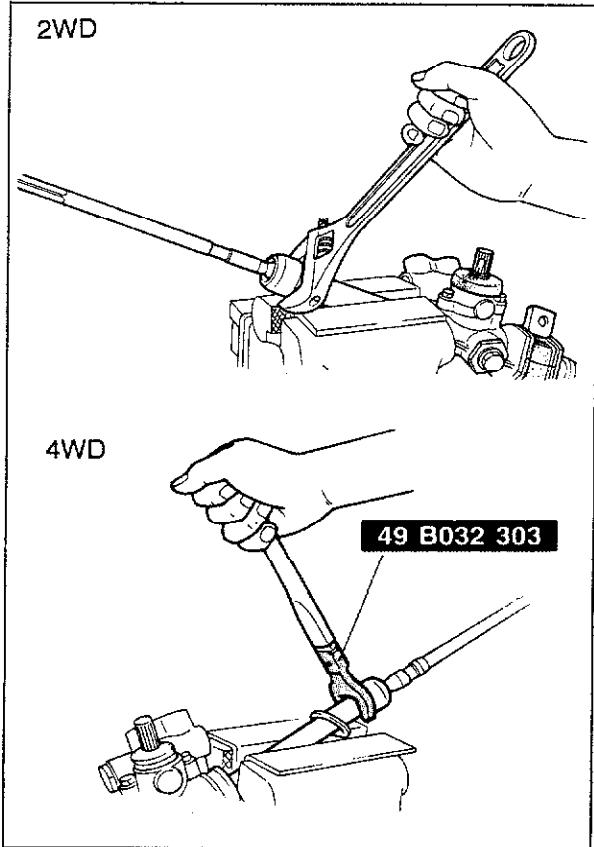

83U10X-063

17. Set the rack in a vise and install new damper ring and washer. Tighten the tie-rod.

**Note**

- a) Mount copper plates in a vise.
- b) Use the SST for 4WD.

**Tightening torque:**

60—80 N·m

(6.0—8.0 m·kg, 43—58 ft·lb)

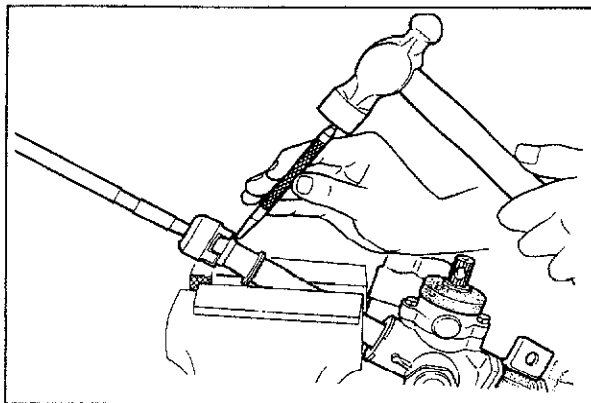

83U10X-064

18. Stake the washer in two places by using a punch. Fit the damper ring in the washer.

# 10 STEERING GEAR AND LINKAGE

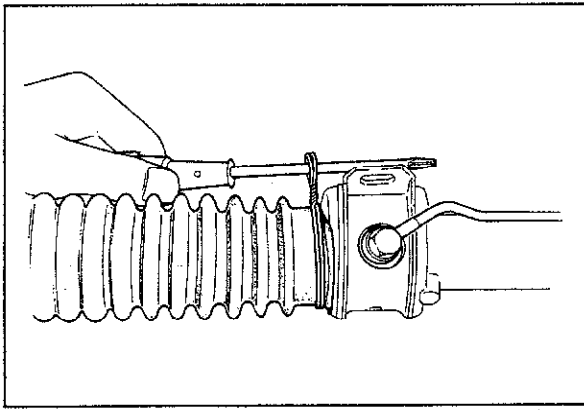

83U10X-065

19. Install the boot, and then wrap a new wire around it two times and twist the wire 4 or 4.5 times.

**Caution**

**Be sure that the boot is not twisted or dented.**

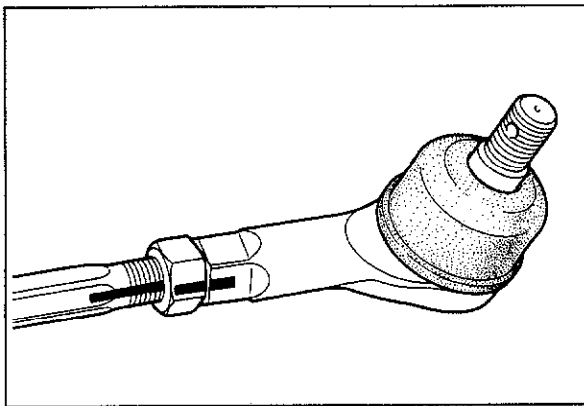

83U10X-066

20. Install the tie-rod ends and align them with the marks made before disassembly.

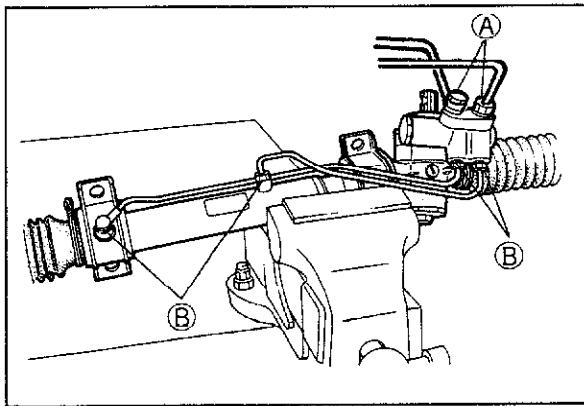

83U10X-067

21. Install the oil pipes.

**Tightening torque:**

**Bolt and nut (A)**

**39—49 N·m (4.0—5.0 m·kg, 29—36 ft·lb)**

**Bolt and nut (B)**

**20—29 N·m (2.0—3.0 m·kg, 14—22 ft·lb)**

## OIL PUMP

## REMOVAL AND INSTALLATION

1. Jack up the front of the vehicle and support it with safety stands.
2. Remove in the sequence shown in the figure.
3. Install in the reverse order of removal.
4. After installation:
  - (1) Check the belt deflection (Refer to page 10—8)
  - (2) Fill the reserve tank with the specified fluid.
  - (3) Bleed air from the system. (Refer to page 10—10)
  - (4) Check for fluid leakage.

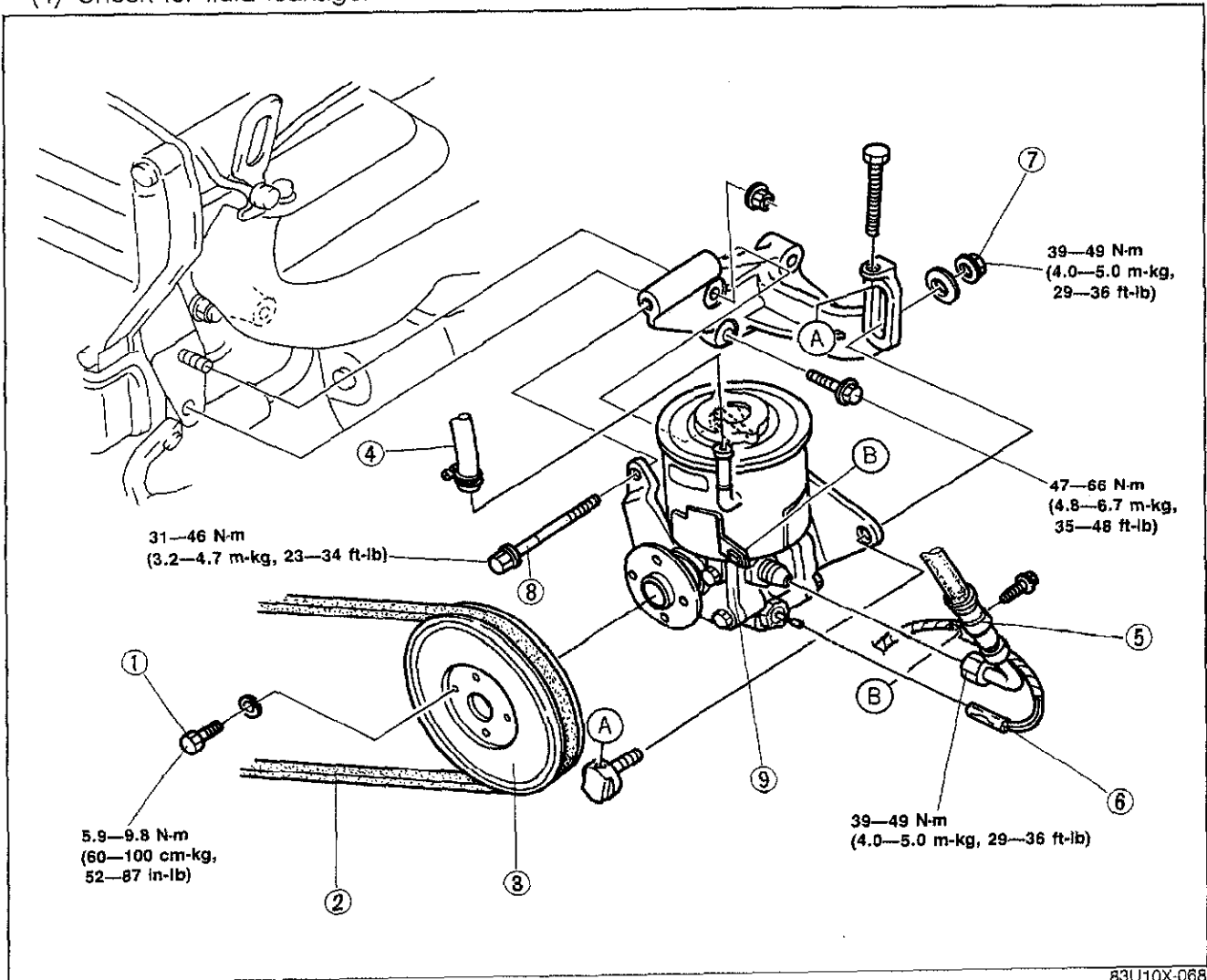

83U10X-068

- |                    |                        |
|--------------------|------------------------|
| 1. Bolt            | 6. Oil pressure switch |
| 2. Oil pump belt   | 7. Nut                 |
| 3. Oil pump pulley | 8. Bolt                |
| 4. Return hose     | 9. Oil pump            |
| 5. Pressure hose   |                        |

**Note**

The power steering fluid will leak out when the return hose or the pressure hose is disconnected, so prepare a suitable container for it to drain into.

83U10X-069

# 10 OIL PUMP

## DISASSEMBLY AND ASSEMBLY

1. Disassemble in the numbered order shown in the figure.
2. Assemble in the reverse order of disassembly.

### Note

- In order to prevent the entry of dirt, disassemble and assemble in a clean area.
- Before disassembly, plug the pipe installation hole, and then remove all oil and dirt from the outside surfaces of the oil pump.
- Before assembly, apply specified power steering fluid to the vanes, rotor, and control valve. Also apply grease (lithium base, NLGI No.2) to the lip of the oil seal.
- Use a new seal kit when assembling.

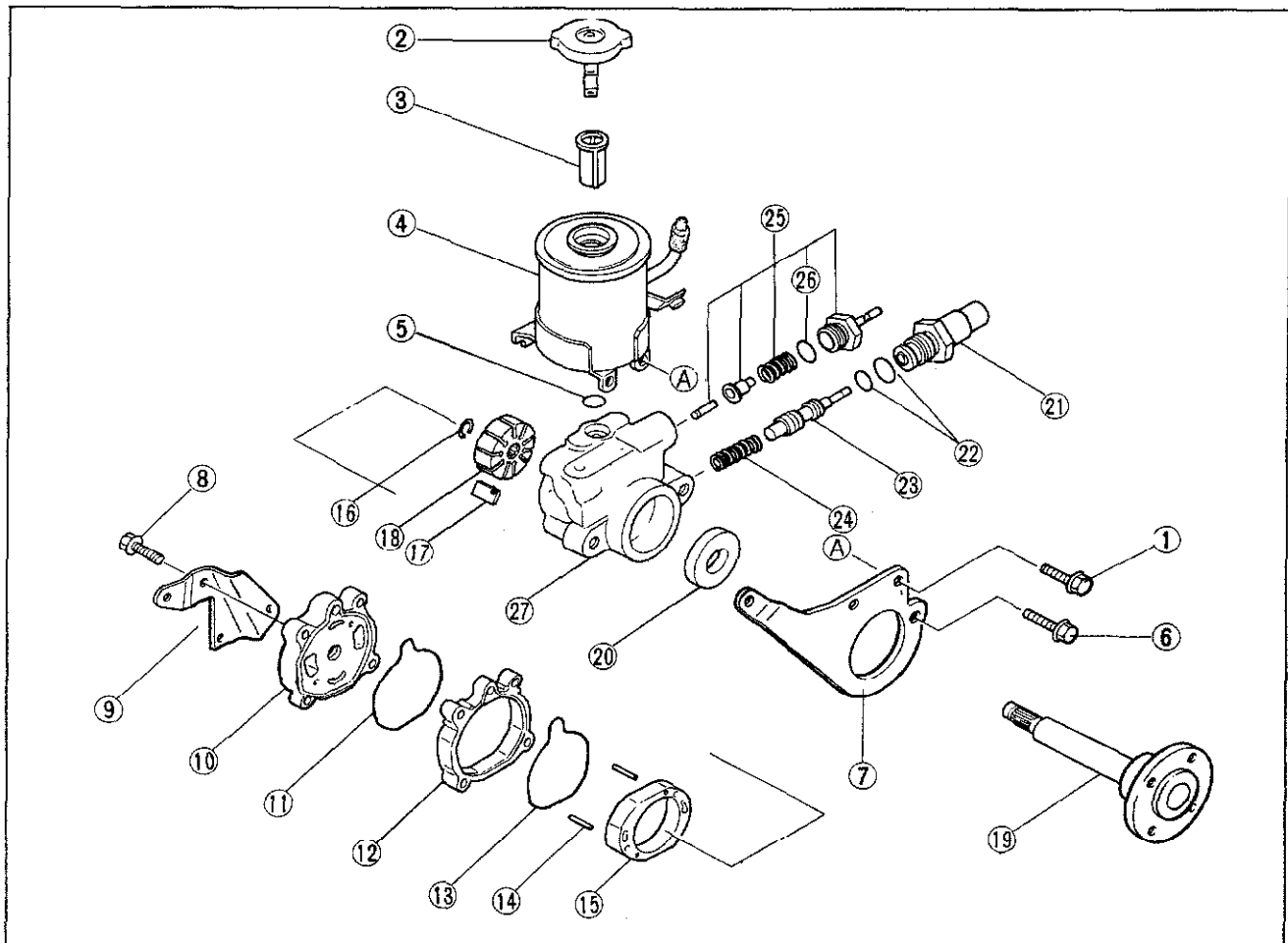

79G10X-042

- |                    |                       |                         |
|--------------------|-----------------------|-------------------------|
| 1. Bolt            | 10. Pump body, rear   | 19. Pump shaft assembly |
| 2. Oil level gauge | 11. O-ring            | 20. Oil seal            |
| 3. Oil strainer    | 12. Pump body, center | 21. Connector           |
| 4. Oil tank        | 13. O-ring            | 22. O-ring              |
| 5. O-ring          | 14. Dowel pin         | 23. Control valve       |
| 6. Bolt            | 15. Cam ring          | 24. Spring              |
| 7. Front bracket   | 16. Snap ring         | 25. Oil pressure switch |
| 8. Bolt            | 17. Vane              | 26. O-ring              |
| 9. Rear bracket    | 18. Rotor             | 27. Pump body, front    |

# BRAKING SYSTEM

<b>OUTLINE</b> .....	11— 2	REMOVAL AND INSTALLATION....	11—21
STRUCTURAL VIEW.....	11— 2	DISASSEMBLY .....	11—22
SPECIFICATIONS.....	11— 4	INSPECTION .....	11—23
<b>TROUBLESHOOTING GUIDE</b> .....	11— 5	ASSEMBLY .....	11—23
<b>ON-VEHICLE MAINTENANCE</b> .....	11— 6	<b>FRONT DISC BRAKE</b> .....	11—26
BRAKE FLUID LEVEL.....	11— 6	REPLACEMENT OF DISC PAD .....	11—26
BRAKE LINES .....	11— 6	REMOVAL AND INSTALLATION....	11—26
SIMPLE INSPECTION OF DISC		INSPECTION.....	11—27
PAD (FRONT).....	11— 6	DISASSEMBLY .....	11—27
SIMPLE INSPECTION OF DISC		INSPECTION.....	11—28
PAD (REAR).....	11— 7	ASSEMBLY .....	11—28
PEDAL HEIGHT.....	11— 7	<b>REAR DRUM BRAKE</b> .....	11—29
PEDAL PLAY .....	11— 7	REMOVAL .....	11—29
PEDAL-TO-FLOOR CLEARANCE....	11— 8	DISASSEMBLY AND ASSEMBLY	
PARKING BRAKE LEVER STROKE	11— 8	OF WHEEL CYLINDER .....	11—32
POWER BRAKE UNIT.....	11— 9	INSPECTION.....	11—33
<b>BRAKE HYDRAULIC LINE</b> .....	11—10	INSTALLATION.....	11—34
STRUCTURAL VIEW.....	11—10	<b>REAR DISC BRAKE</b> .....	11—38
REMOVAL AND INSTALLATION....	11—11	REPLACEMENT OF DISC PAD .....	11—38
REPLACEMENT OF BRAKE FLUID	11—11	REMOVAL .....	11—40
AIR BLEEDING.....	11—11	DISASSEMBLY AND ASSEMBLY ...	11—41
<b>BRAKE PEDAL</b> .....	11—13	INSPECTION.....	11—45
REMOVAL AND INSTALLATION ....	11—13	INSTALLATION.....	11—46
INSPECTION.....	11—13	<b>DUAL PROPORTIONING VALVE</b> ....	11—47
<b>MASTER CYLINDER</b> .....	11—14	FUNCTION CHECK.....	11—47
REMOVAL AND INSTALLATION....	11—14	REMOVAL AND INSTALLATION....	11—48
DISASSEMBLY AND ASSEMBLY ...	11—16	<b>PARKING BRAKE LEVER</b> .....	11—49
INSPECTION.....	11—18	REMOVAL AND INSTALLATION....	11—49
<b>POWER BRAKE UNIT</b> .....	11—19	INSPECTION .....	11—49
ON-VEHICLE INSPECTION .....	11—19	<b>PARKING BRAKE CABLE</b> .....	11—50
CHECK VALVE.....	11—20	REMOVAL AND INSTALLATION....	11—50

## OUTLINE

### STRUCTURAL VIEW

Front disc, rear drum model

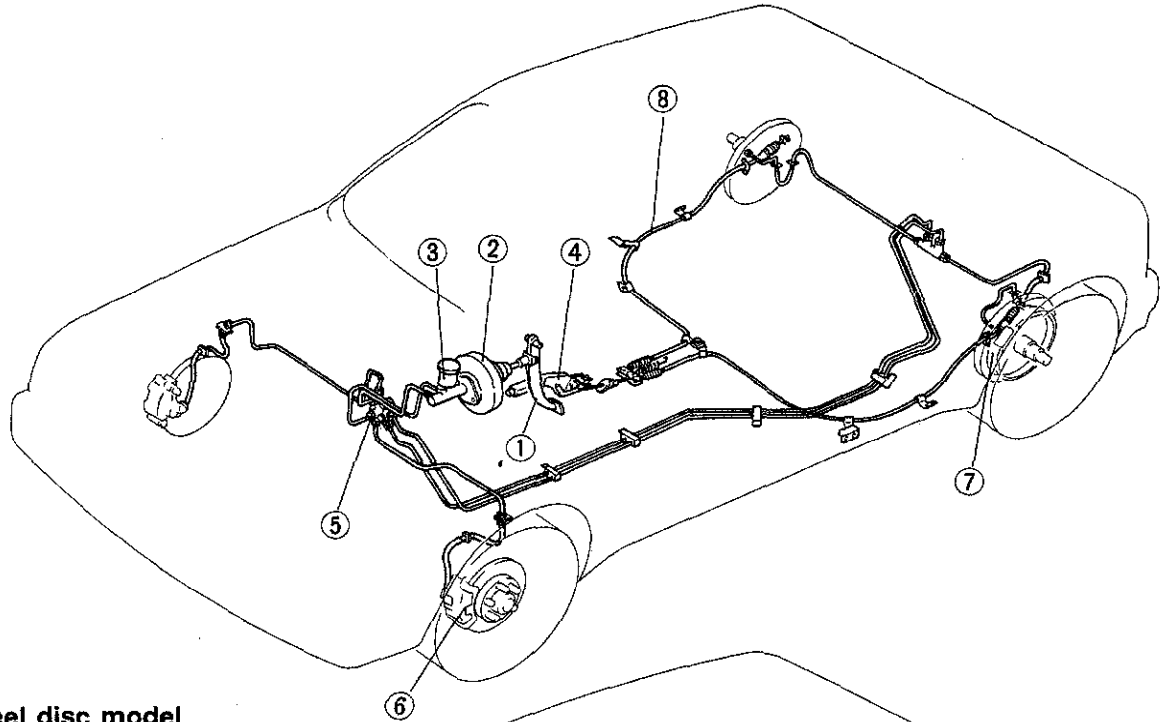

4-wheel disc model

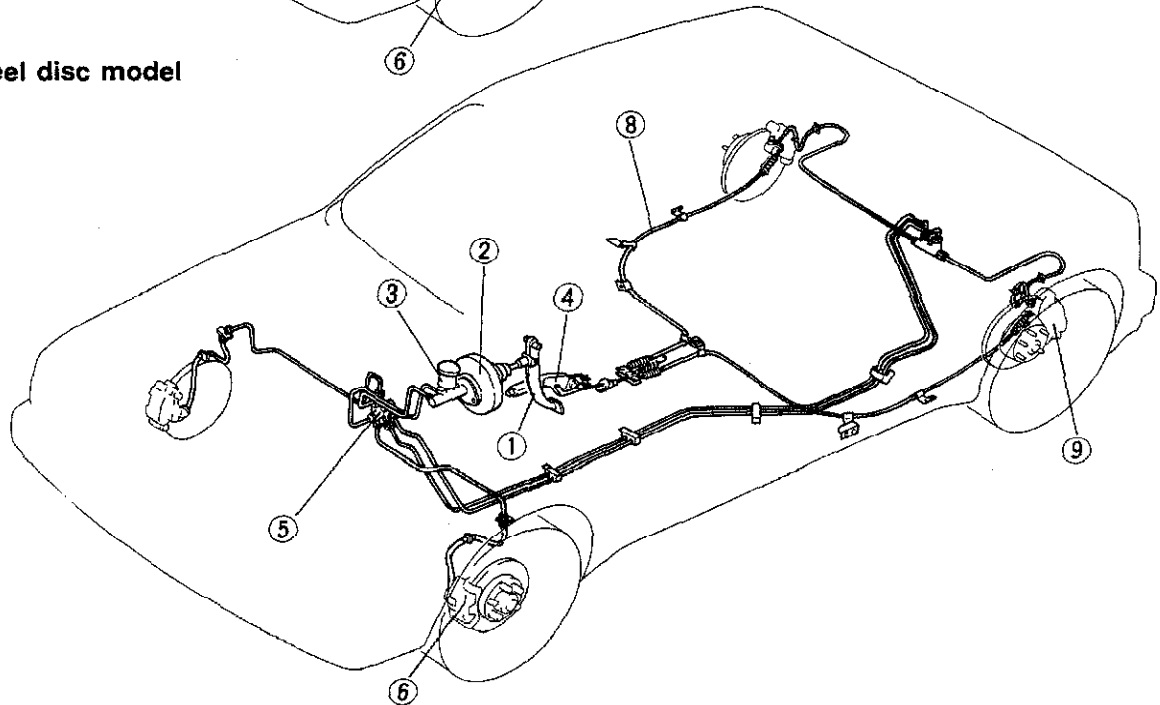

63U11X-002

- 1. Brake pedal
- 2. Power brake unit
- 3. Brake master cylinder

- 4. Parking brake lever
- 5. Dual proportioning valve
- 6. Front disc brake

- 7. Rear drum brake
- 8. Parking brake cable
- 9. Rear disc brake

**Front disc brake**  
Ventilated disc

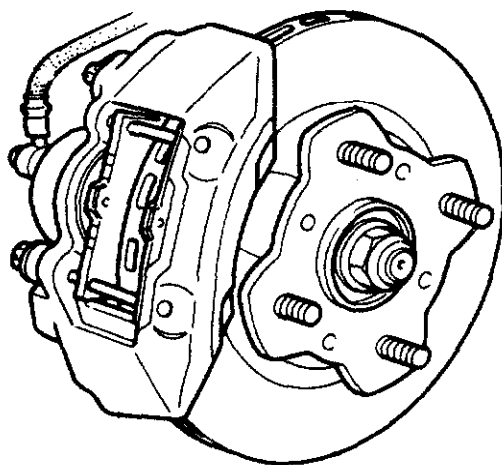

**Rear disc brake**  
Solid disc

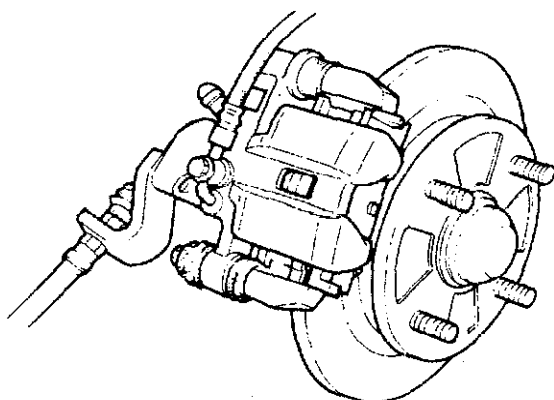

**Rear drum brake**  
Leading-trailing

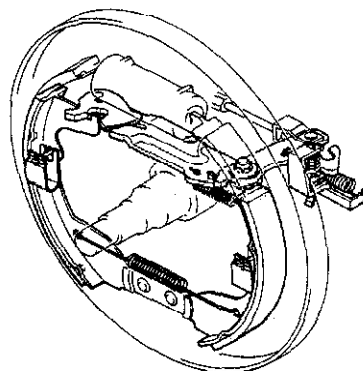

# 11 OUTLINE

## SPECIFICATIONS

Item		Specification
Brake pedal	Type	Suspended
	Pedal lever ratio	4.63
	Max. stroke	mm (in) 145 (5.71)
Master cylinder	Type	Tandem (with level sensor)
	Cylinder inner diameter	mm (in) 22.22 (0.875)
Front disc brake	Type	Ventilated disc (integral)
	Cylinder bore	mm (in) 51.1 (2.01)
	Pad dimensions (area x thickness) mm <sup>2</sup> (in <sup>2</sup> ) x mm (in)	3,800 (5.89) x 10 (0.39)
	Disc plate dimensions (outer diameter x thickness)	mm (in) 13 inch-wheel : 238 x 18 (9.37 x 0.71) 14 inch-wheel : 260 x 18 (10.24 x 0.71)
Rear disc brake	Type	Sold disc (mounting support)
	Cylinder bore	mm (in) 30.2
	Pad dimensions (area x thickness) mm <sup>2</sup> (in <sup>2</sup> ) x mm (in)	2,728 x 8 (4.23 x 0.31)
	Disc plate dimensions (outer diameter x thickness)	mm (in) 247 x 10 (9.72 x 0.39)
Rear drum brake	Type	Leading-trailing
	Wheel cylinder inner diameter	mm (in) 17.46 (0.687)
	Lining dimensions (width x length x thickness)	mm (in) 25 x 191.9 x 5 (0.98 x 7.56 x 0.19)
	Drum inner diameter	mm (in) 200 (7.87)
	Shoe clearance adjustment	Automatic adjuster
Power brake unit	Type	Vacuum multiplier
	Diameter	213 (8.39)
Braking force control device	Type	Dual proportioning valve
Brake fluid		FMVSS 116, DOT-3 or DOT-4, or SAE J1703a
Parking brake	Type	Mechanical two rear wheel control
	Operation system	Center lever

83U11X-003



**TROUBLESHOOTING GUIDE**

<b>Problem</b>	<b>Possible cause</b>	<b>Remedy</b>	<b>Page</b>
<b>Poor braking</b>	Leakage of brake fluid	Repair	—
	Air in system	Air bleed	11—11
	Worn pad or lining	Replace	11—26,29,38
	Brake fluid, grease, oil or water on pad or lining	Clean or replace	11—26,29,38
	Hardening of pad or lining surface, or poor contact	Grind or replace	11—26,29,38
	Malfunction of disc brake piston	Replace	11—27,41
	Malfunction of master cylinder or wheel cylinder	Repair or replace	11—14,30
	Malfunction of power brake unit	Repair or replace	11—21
	Malfunction of check valve (vacuum hose)	Repair or replace	11—21
	Damaged vacuum hose	Replace	—
	Deterioration of flexible hose	Replace	—
Malfunction of dual proportioning valve	Replace	11—48	
<b>Brakes pull to one side</b>	Worn pad or lining	Replace	11—26,29,38
	Brake fluid, grease, oil or water on pad or lining	Clean or replace	11—26,29,38
	Hardening of pad or lining surface, or poor contact	Grind or replace	11—26,29,38
	Abnormal wear, distortion of disc or lining	Repair or replace	—
	Malfunction of automatic adjuster	Repair or replace	—
	Looseness or deformation of backing plate mounting bolt	Tighten or replace	11—34
	Malfunction of wheel cylinder	Repair or replace	11—30
	Improper adjustment of wheel bearing preload, or wear	Refer to Section 9	—
	Improper adjustment of wheel alignment	Refer to Section 10	—
	Unequal tire air pressures	Refer to Section 12	—
<b>Brakes do not release</b>	No brake pedal play	Adjust	11— 7
	Improper adjustment of operating rod or push rod	Adjust	11—15
	Clogged master cylinder return port	Clean	—
	Shoe does not return properly	Adjust	—
	Wheel cylinder does not return properly	Clean or replace	11—30
	Improper return due to malfunction of piston seal of disc brake	Replace	11—27,41
	Excessive runout of disc plate	Replace	—
	Improper return of parking brake cable, or improper adjustment	Repair or adjust	11— 8
Improper adjustment of wheel bearing preload	Refer to Section 9	—	
<b>Pedal goes too far (Too much pedal stroke)</b>	Air in system due to insufficient brake fluid	Add fluid and bleed air.	11—11
	Improper adjustment of pedal play	Adjust	11— 7
	Worn pad or lining	Replace	11—26,29,38
	Air in system	Air bleed	11—11
<b>Abnormal noise or vibration during braking</b>	Worn pad or lining	Replace	11—26,29,38
	Deterioration of pad or lining surface	Grind or replace	11—26,29,38
	Brakes do not release	Repair	—
	Foreign material or scratches on disc plate or drum contact surface	Clean	—
	Looseness of backing plate or caliper mounting bolts	Tighten	11—34
	Damage or deviation of disc or drum contact surface	Replace	—
	Poor contact of pad or lining	Repair or replace	11—26,29,38
	Insufficient grease on sliding parts	Apply grease.	—
<b>Parking brake does not hold well</b>	Excessive lever stroke	Adjust	11— 8
	Brake cable stuck or damaged	Repair or replace	11—50
	Brake fluid or oil on pad or lining	Clean or replace	11—26,29,38
	Hardening of pad or lining surface, or poor contact	Grind or replace	—

83U11X-004

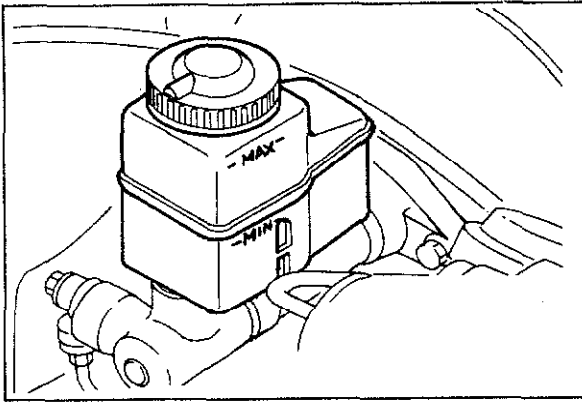

83U11X-005

## ON-VEHICLE MAINTENANCE

### BRAKE FLUID LEVEL

Check fluid level in reservoir. It should be between the "Max" and "Min" lines on the reservoir.

If the fluid level is extremely low, check the brake system for leaks.

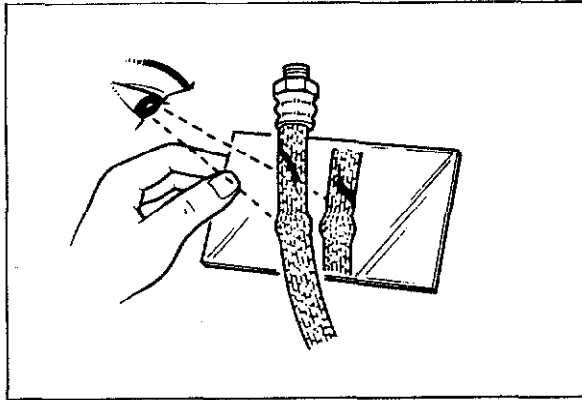

83U11X-006

### BRAKE LINES

Check the following and replace or repair any faulty parts.

1. Cracks damage and corrosion of brake hose
2. Damage to brake hose threads
3. Scars, cracks and swelling of flexible hose
4. Fluid leakage of all lines

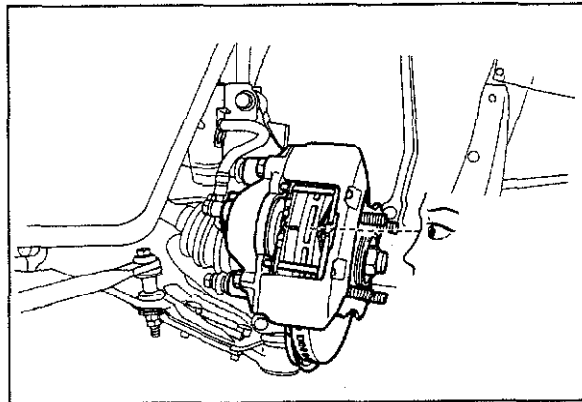

83U11X-007

### SIMPLE INSPECTION OF DISC PAD (Front)

1. Loosen the front wheel lug nuts.
2. Jack up the front of the vehicle, and support it with safety stands.
3. Remove the wheels.
4. Check through the caliper inspection hole and see if the remaining thickness of the pad is at least **2 mm (0.08 in)**

#### Note

**When the remaining thickness becomes 2 mm (0.08 in), the wear indicator indicates that the pad should be replaced by creating a squealing noise while driving.**

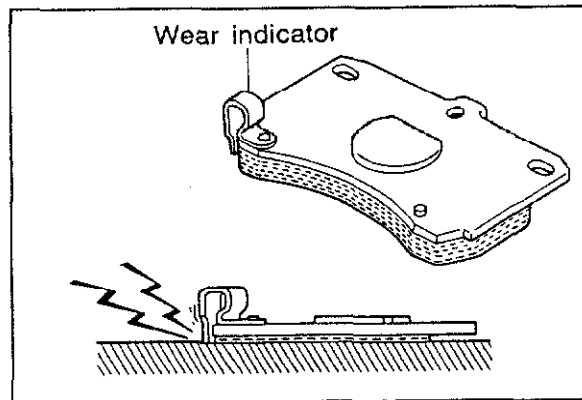

83U11X-065

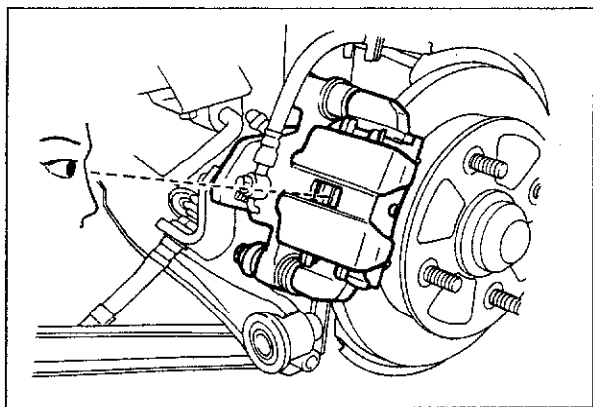

83U11X-008

## SIMPLE INSPECTION OF DISC PAD (Rear)

1. Loosen the rear wheel lug nuts.
2. Jack up the rear of the vehicle, and support it with safety stands.
3. Remove the wheels.
4. Check through the caliper inspection hole and see if the remaining thickness of the pad is at least **1 mm (0.04 in)**.

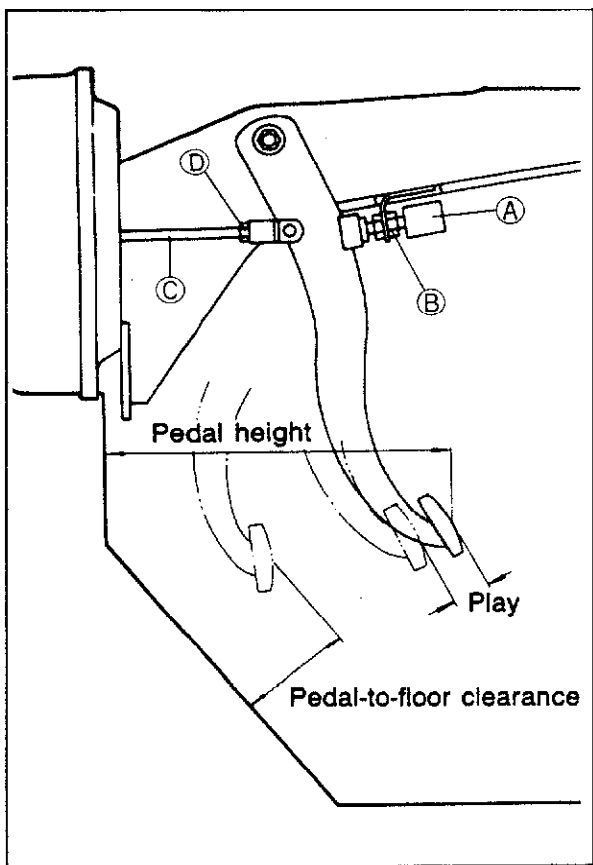

83U11X-009

## PEDAL HEIGHT

### Inspection

Check that the distance from the center of the upper surface of the pedal pad to the firewall is as specified.

**Pedal height: 214 ± 5 mm (8.43 ± 0.20 in)**

### Adjustment

1. Disconnect the stop light switch connector.
2. Loosen locknut B and turn switch A until it does not contact the pedal.
3. Loosen locknut D and turn rod C to adjust the height.
4. Adjust the pedal free play and tighten locknut D.
5. Turn the stop light switch until it contacts the pedal; then turn an additional 1/2 turn. Tighten locknut B.

### Locknut B tightening torque:

**14—18 N·m (1.4—1.8 m·kg, 10—13 ft·lb)**

### Locknut D tightening torque:

**24—34 N·m (2.4—3.5 m·kg, 17—25 ft·lb)**

6. Connect the stop light switch connector.

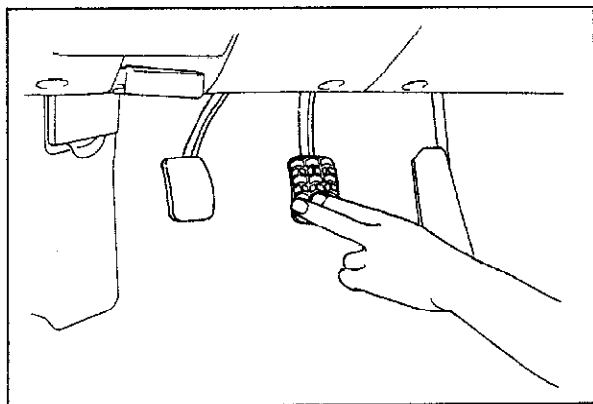

63U11X-011

## PEDAL PLAY

### Inspection

1. Depress the pedal a few times in order to eliminate the vacuum in the vacuum line.
2. Gently depress the pedal by hand and check the free play.  
(Until the valve plunger contacts the stopper plate; until resistance is felt)

**Pedal play: 4—7 mm (0.16—0.28 in)**

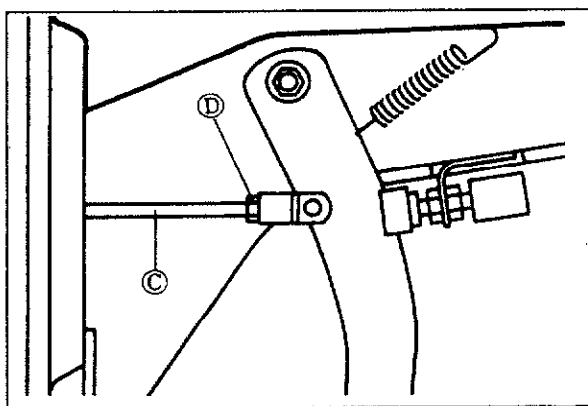

86U11X-018

## Adjustment

Loosen the locknut D of the operating rod C; then turn the rod to adjust the free play.

## Locknut D tightening torque:

24—34 N·m (2.4—3.5 m·kg, 17—25 ft·lb)

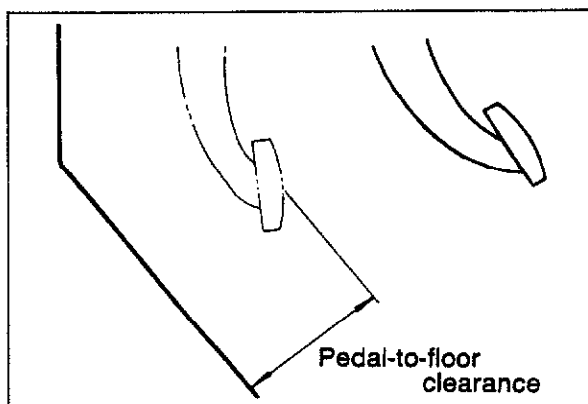

83U11X-010

## PEDAL-TO-FLOOR CLEARANCE

### Inspection

Check that the distance from the floor panel to the center of the upper surface of the pedal pad is the standard value when the pedal is depressed with a force of 60 kg (132.3 lb).

**Pedal-to-floor clearance: 83 mm (3.27 in) min.**

If the distance is less than the standard value, check as described below.

1. Air in brake system
2. Malfunction of automatic adjuster
3. Worn shoes or pads

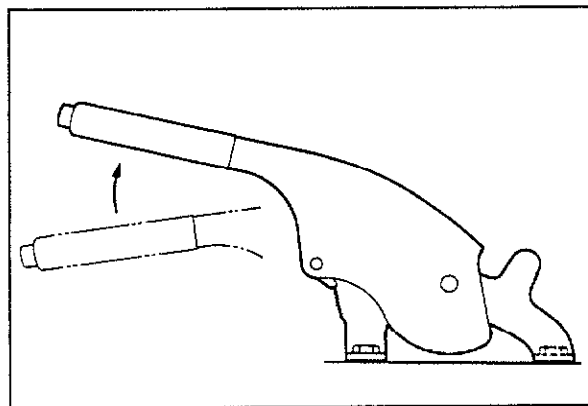

83U11X-011

## PARKING BRAKE LEVER STROKE

### Inspection

Check whether the stroke of the parking brake lever is within the standard value range when it is pulled by applying a force of 10 kg (22 lb).

**Stroke: 5—7 notches**

## Adjustment

1. Before adjustment, depress the brake pedal several times while the vehicle is moving in reverse to adjust the automatic adjusters.
2. After loosening the locknut, turn the adjusting nut at the front of the brake cable.
3. Check to be sure that the parking brake warning lamp illuminates when the brake lever is pulled one notch.

## Caution

- a) Check to be sure that the brakes do not drag.
- b) Make the adjustment after starting the engine and depressing the brake pedal 2 to 3 time.

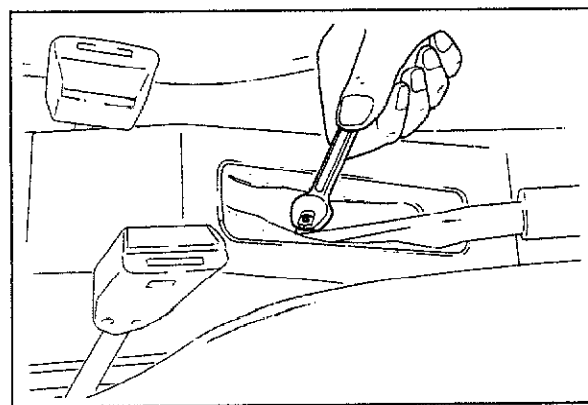

83U11X-088

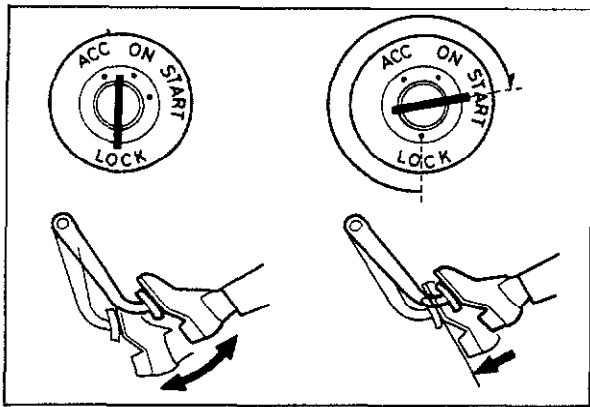

63U11X-016

## POWER BRAKE UNIT

### First Step

1. With the engine stopped, depress the pedal a few times.
2. With the pedal depressed, start the engine.
3. If, immediately after the engine starts, the pedal moves down slightly, the unit is good.

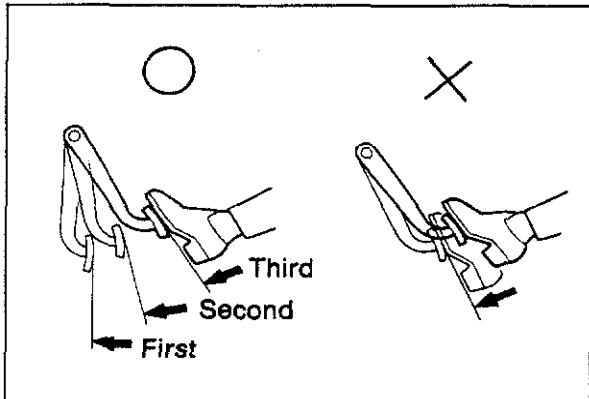

63U11X-017

### Second Step

1. Start the engine.
2. Stop the engine after it has run for **1 or 2 minutes**.
3. Depress the pedal with the usual force.
4. If the first pedal stroke is long and becomes shorter with subsequent strokes, the unit is serviceable.
5. If there is a problem, check for damage of the check valve or vacuum hose, and check for proper connection. Repair if necessary, and check once again.

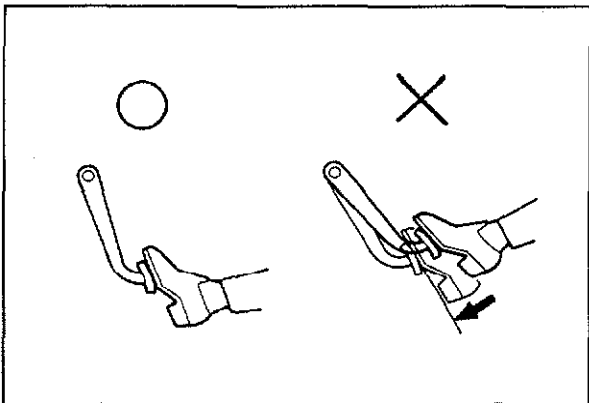

83U11X-012

### Third Step

1. Start the engine.
2. Depress the pedal with the usual force.
3. Stop the engine with the pedal still depressed.
4. Hold the pedal down for **about 30 seconds**.
5. If the pedal height does not change, the unit is serviceable.
6. If there is a problem, check for damage of the check valve or vacuum hose, and check for proper connection. Repair if necessary, and check once again.

If the nature of the problem is still not clear after following the 3 steps above, follow the more detailed check described in "Method using a tester." See page 11—19.

# 11 BRAKE HYDRAULIC LINES

## BRAKE HYDRAULIC LINES

### STRUCTURAL VIEW

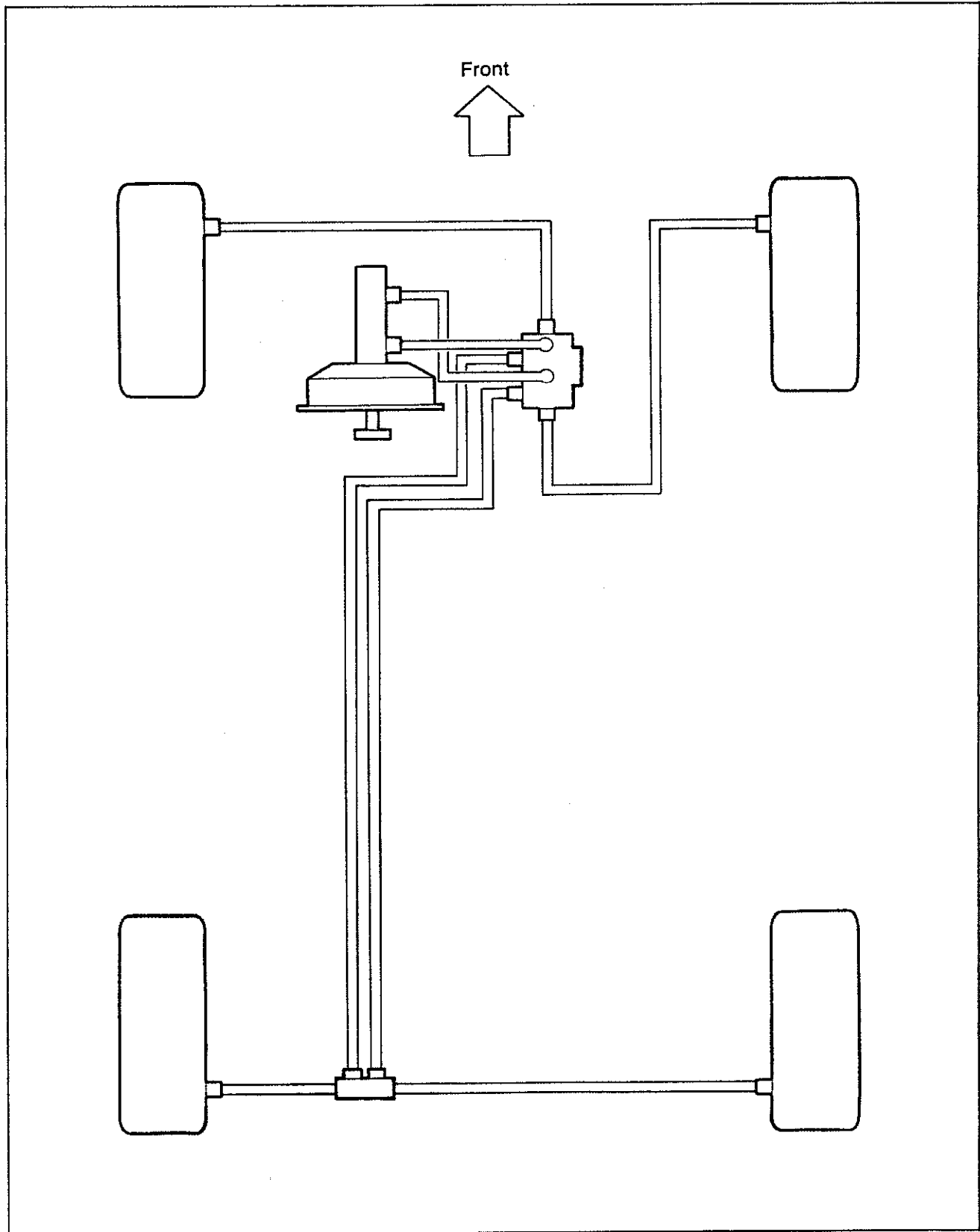

83U11X-013

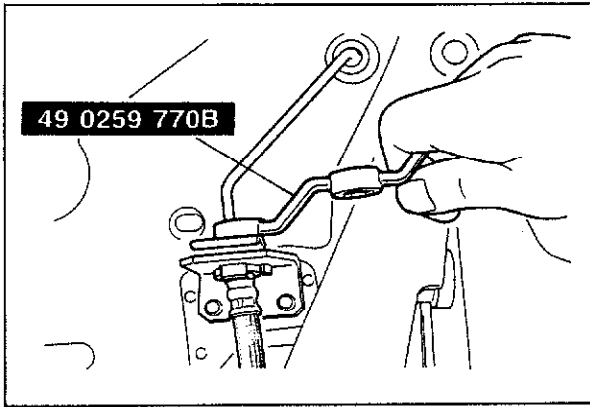

83U11X-066

### REMOVAL AND INSTALLATION

1. When disconnecting the flexible hose and brake line, remove the clip after loosening the flare nut.
2. When connecting the flexible hose, do not tighten too tight or twist.
3. Check that the hose does not contact other parts when the vehicle bounces, or when the steering wheel is turned all the way to the right or left.
4. Bleed air as described below.

#### Caution

**Do not allow the brake fluid to get on painted surfaces. If it does wipe it off immediately.**

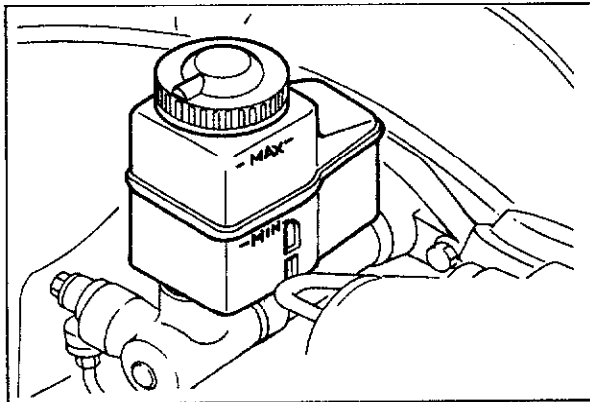

83U11X-014

### REPLACEMENT OF BRAKE FLUID

1. Remove the brake fluid from the reservoir by using a suction pump.
2. Fill the reservoir with new brake fluid.
3. Attach a vinyl tube to the bleeder screw and place the other end of the vinyl tube in a container.
4. Pump out the old brake fluid by loosening each bleeder screw (one by one) and pumping the brake pedal.
5. Bleed air as described below.

#### Caution

**Do not allow the brake fluid to get on painted surfaces. If it does wipe it off immediately.**

### AIR BLEEDING

After repairs, air bleed as follows:

Disassembly locations			Air bleeding locations			
			Front		Rear	
			Right side	Left side	Left side	Right side
Master cylinder			x	x	x	x
Wheel cylinder or caliper	Front	Right side	x	x	—	—
		Left side	x	x	—	—
	Rear	Right side	—	—	x	x
		Left side	—	—	x	x
Dual proportioning valve			x	x	x	x

x indicates locations where air bleeding is necessary.

63U11X-022

# 11 BRAKE HYDRAULIC LINES

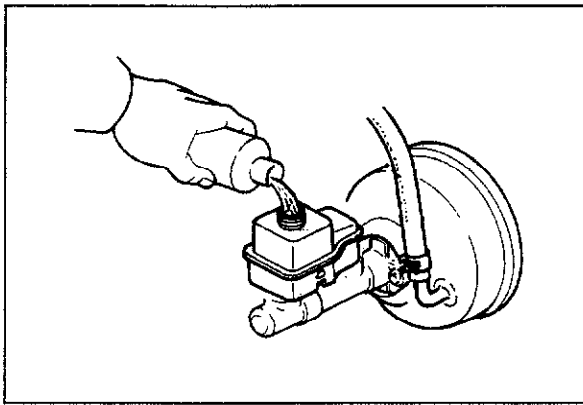

63U11X-023

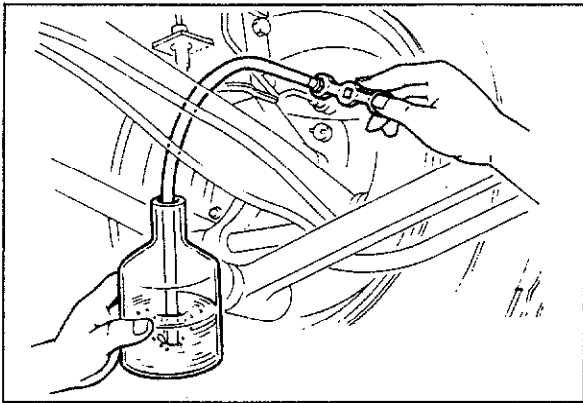

63U11X-024

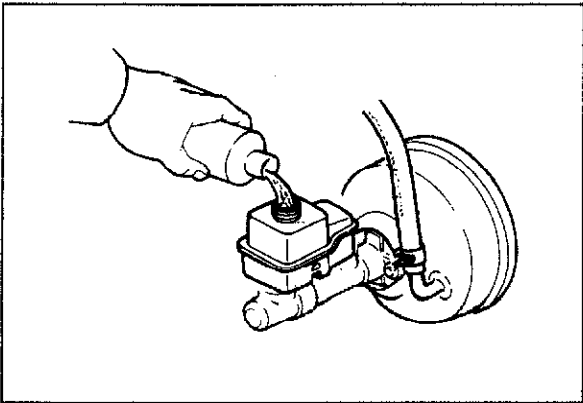

63U11X-025

Bleed air as described below.

## Caution

- a) The fluid in the reservoir must be maintained at the 2/4 level or higher during air bleeding.
- b) Be careful not to spill brake fluid onto painted surfaces.

1. Jack up the vehicle and support it with safety stands.
2. Remove the bleeder cap and attach a vinyl hose to the bleeder plug.
3. Place the other end of the vinyl tube in a container.
4. Slowly pump the brake pedal several times.
5. While the brake pedal is pressed, loosen the bleeder screw to let fluid and air escape.
6. Repeat steps 4 and 5 until there are no air bubbles in the fluid.
7. Check for correct brake operation.
8. Check that there is no fluid leakage. Clean away any spilled fluid with rags.
9. After bleeding the air, add brake fluid to the reservoir up to the specified level.



## BRAKE PEDAL

### REMOVAL AND INSTALLATION

1. Remove the parts in the numbered sequence shown in the figure.
2. Install in the reverse order of removal.
3. After installation, check and adjust the pedal height and free play if necessary.

**Caution**

**Apply grease to the inner surface of the bushing, and to the contact surfaces of the clevis pin and spring.**

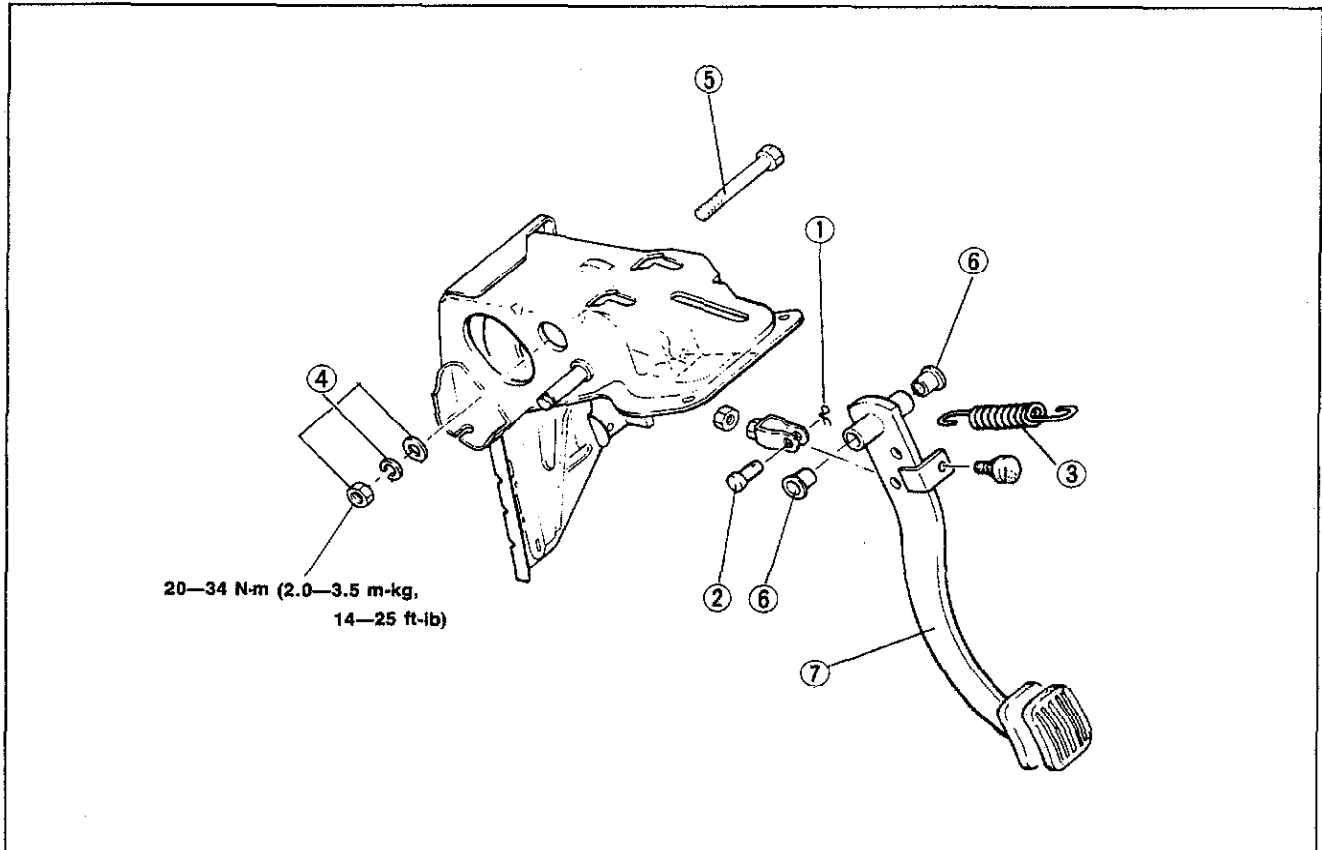

63U11X-026

- |                  |                                     |             |
|------------------|-------------------------------------|-------------|
| 1. Cotter pin    | 4. Nut, lock washer and flat washer | 6. Bushings |
| 2. Clevis pin    | 5. Bolt                             | 7. Pedal    |
| 3. Return spring |                                     |             |

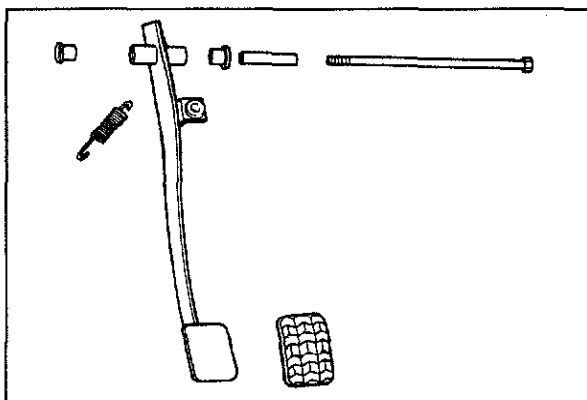

63U11X-027

### INSPECTION

Check the following points, replace if necessary.

1. Bushing for wear
2. Pedal for bending
3. Pedal pad for wear or damage
4. Bolt for bending
5. Return spring for weakness or damage

# 11 MASTER CYLINDER

## MASTER CYLINDER

### REMOVAL AND INSTALLATION

1. Remove the parts in the numbered sequence shown in the figure.
2. Install in the reverse order of removal.
3. After installation, add brake fluid and bleed the air; then check each part for fluid leakage.

#### Caution

Brake fluid will damage painted surfaces. If it does get on a painted surface, clean it immediately.

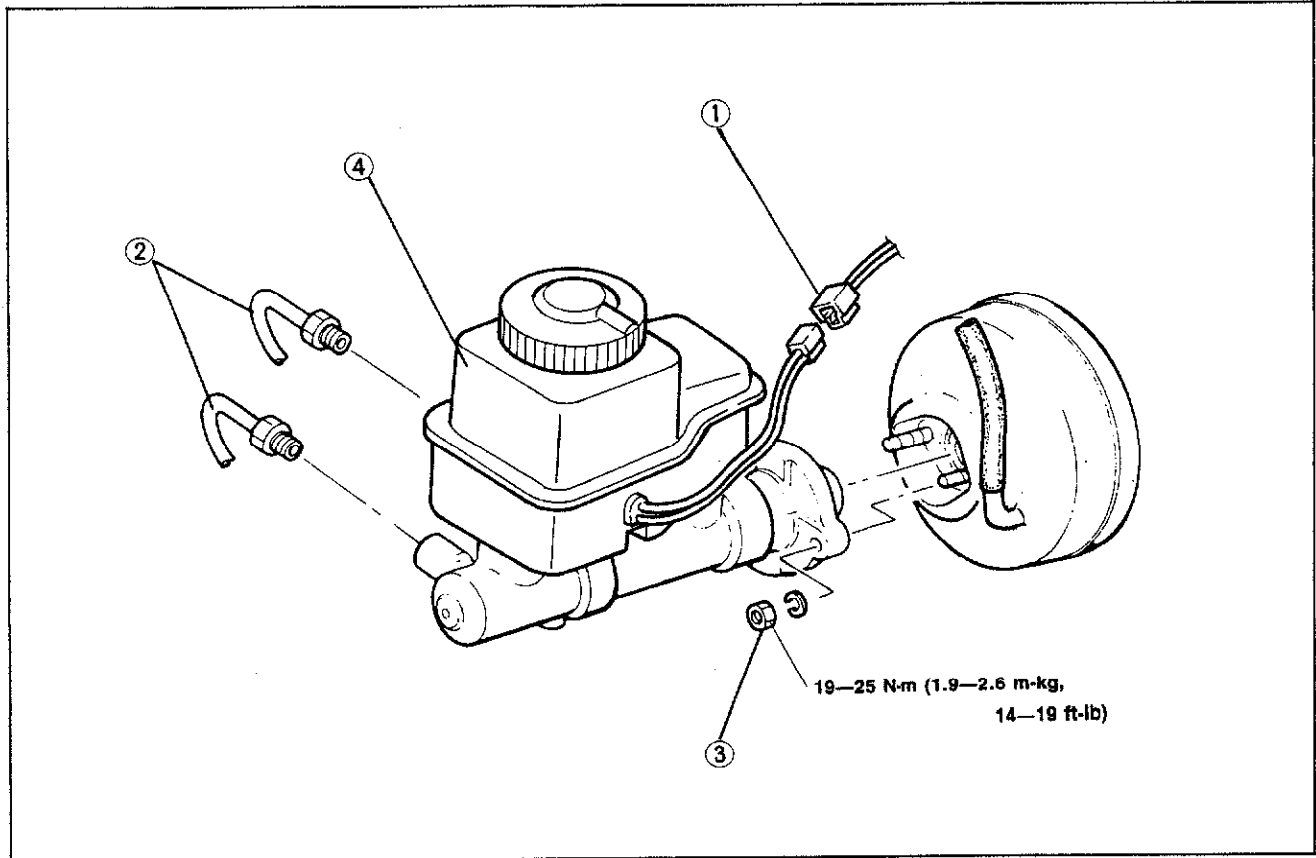

63U11X-028

1. Fluid level sensor
2. Brake pipe

3. Nut
4. Reservoir and master cylinder

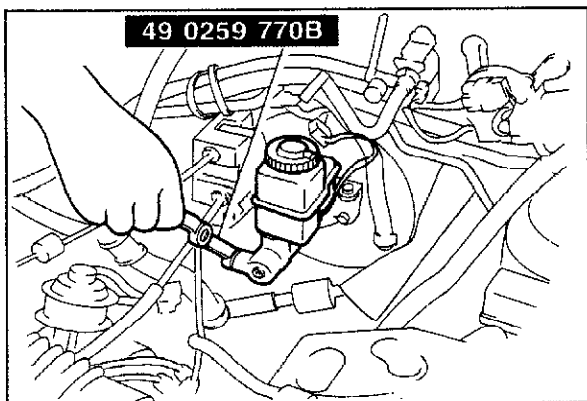

83U11X-067

#### Brake Pipe

Disconnect the brake pipe from the master cylinder with SST.

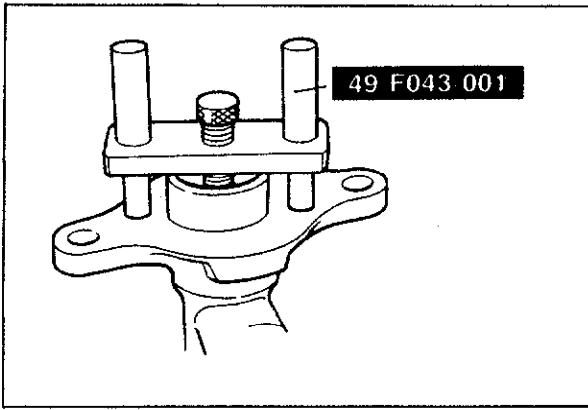

83U11X-015

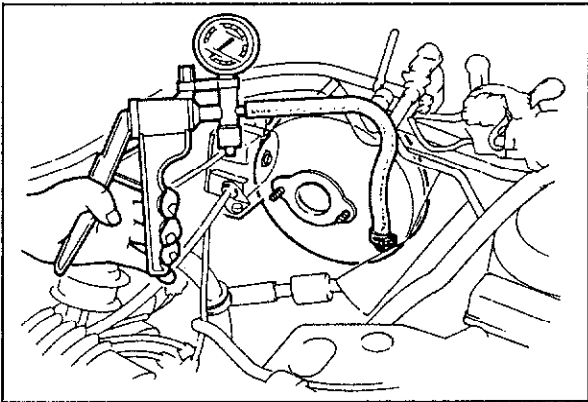

86U11X-035

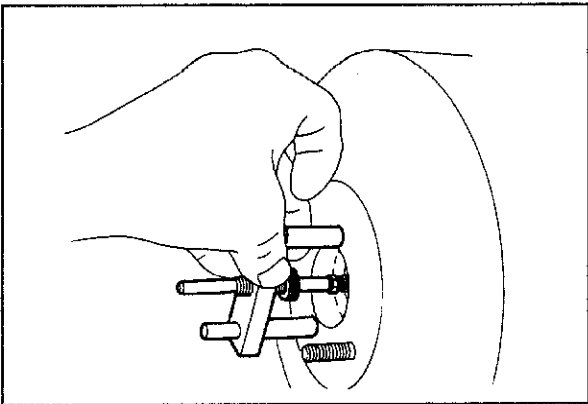

86U11X-036

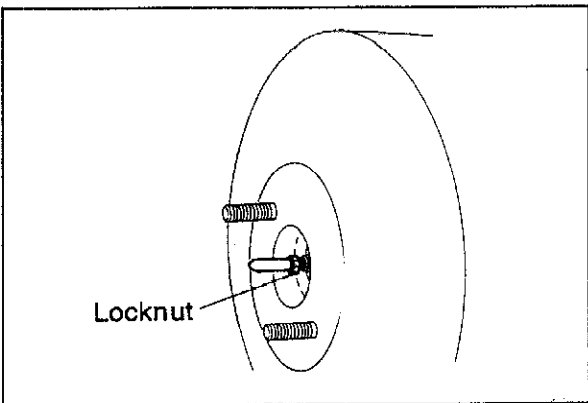

86U11X-037

## Piston to Push Rod Clearance

Before installing the master cylinder, check the clearance between the piston of the master cylinder and the push rod of the power brake unit as follows.

1. Place the **SST** on the top of the master cylinder; then turn the adjust bolt until it contacts the bottom of the push rod hole in the piston.

2. Apply **500 mm-Hg (19.7 in-Hg)** vacuum to the power brake unit with a vacuum pump.

3. Invert the adjustment gauge used in step 1, and place it on the power brake unit.

4. Check the clearance between the end of the gauge and the push rod of the power brake unit. If it is not **0 mm**, loosen the push rod locknut and turn the push rod to adjust.

# 11 MASTER CYLINDER

## DISASSEMBLY AND ASSEMBLY

1. After removing the brake fluid, disassemble the brake master cylinder in the numbered sequence shown in the figure.
2. Assemble in the reverse order of removal.

### Caution

- a) Secure the master cylinder flange in a vise when securing.
- b) Use a new piston cup and O-ring. Note that the primary side is replaced as the piston assembly.
- c) Do not let foreign material in, and do not scratch the inside of the cylinder or the outer surface of the piston.

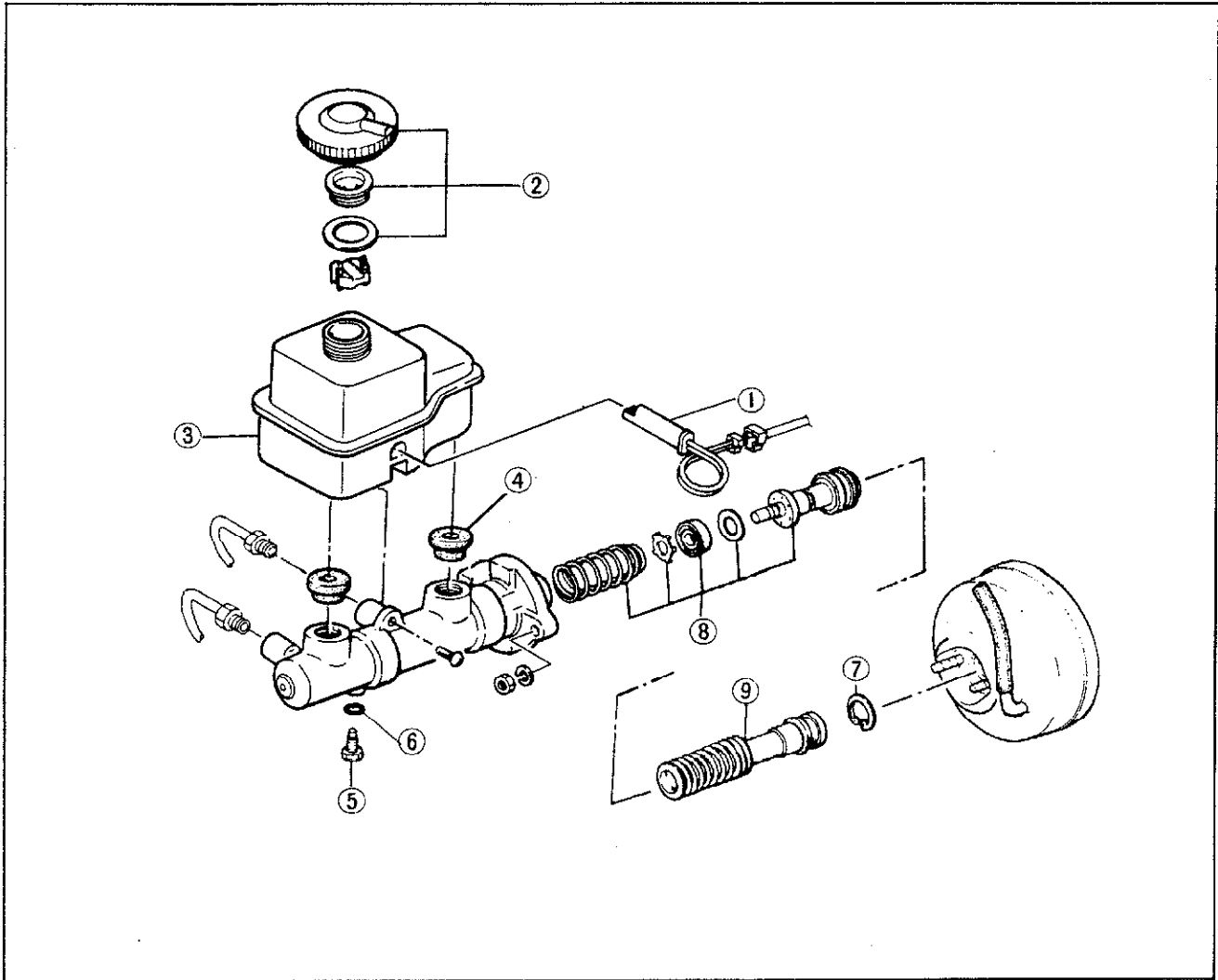

73U11X-509

1. Fluid level sensor
2. Reservoir cap
3. Reservoir

4. Bushing
5. Stopper screw
6. O-ring

7. Stop ring
8. Primary piston assembly
9. Secondary piston assembly

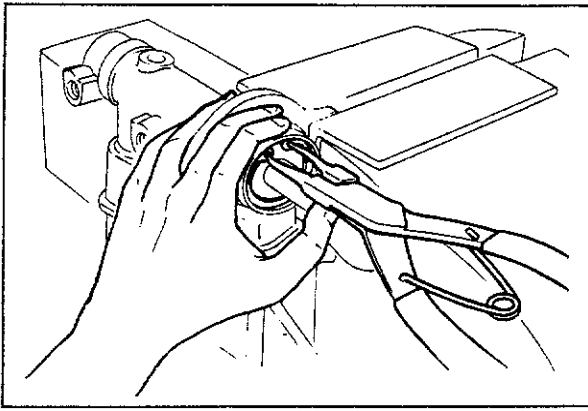

73U11X-510

### Stop Ring

Push the piston by hand, remove or install the stop ring using snap-ring pliers.

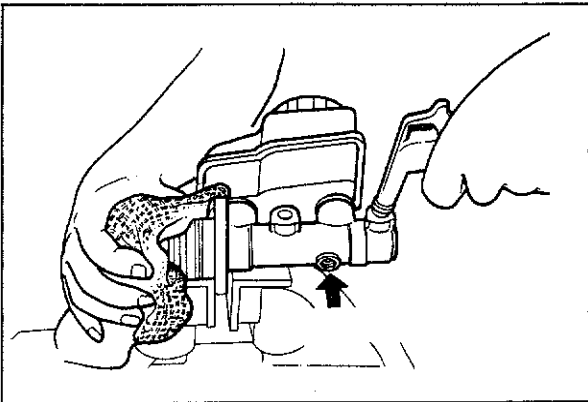

73U11X-511

### Secondary Piston Assembly

Remove the secondary piston assembly by gradually blowing compressed air into the cylinder.

### Caution

Use a rag to catch the secondary piston assembly when blowing compressed air.

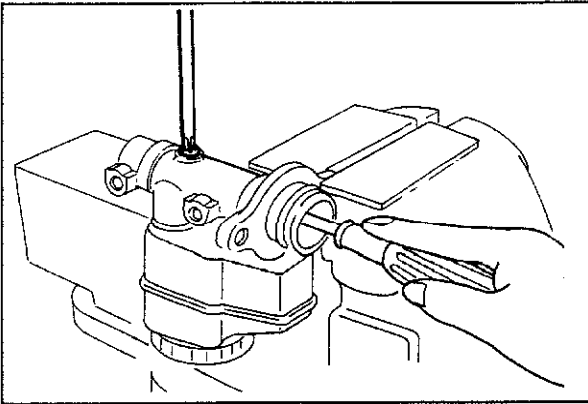

63U11X-034

### Stopper Screw

1. When installing the stopper screw, use a cross-tipped screwdriver to push the primary piston assembly in all the way.
2. Tighten the stopper screw.
3. Push and release the screwdriver to check that the position of the stopper screw is correct.

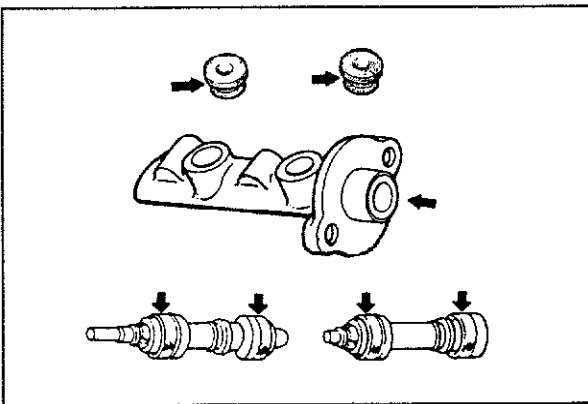

73U11X-512

### Application of Brake Fluid

Before assembly, apply brake fluid to the following parts:

1. Cylinder inner surface.
2. Piston cups
3. Bushings

# 11 MASTER CYLINDER

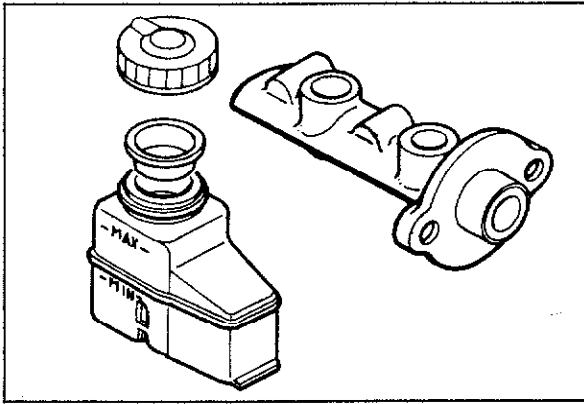

63U11X-036

## INSPECTION

Check the following points, replace parts if necessary,

1. Piston and the cylinder bore for abnormal wear, rust or damage.
2. Springs for weakness or damage.
3. Reservoir for damage, or deformation.

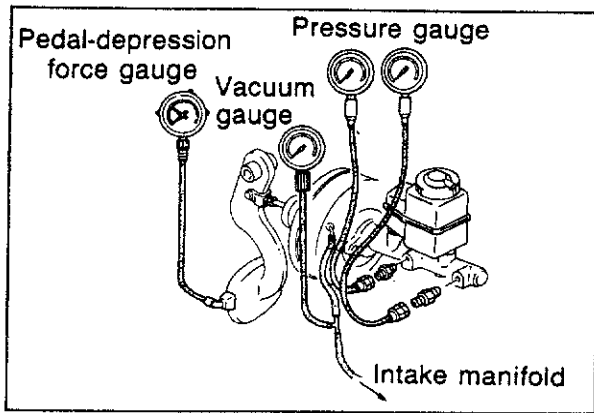

83U11X-037

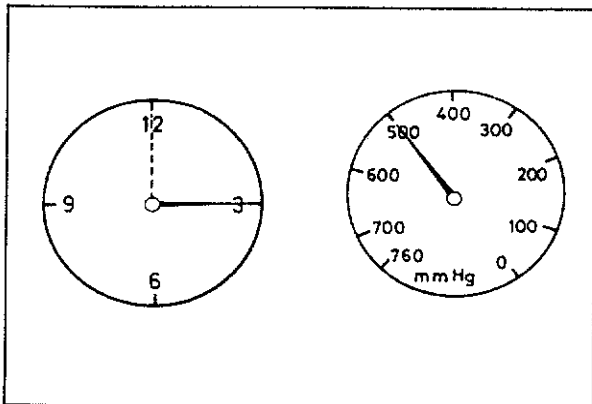

63U11X-038

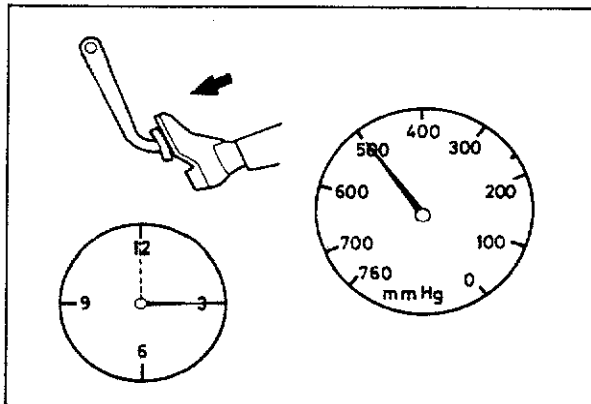

63U11X-039

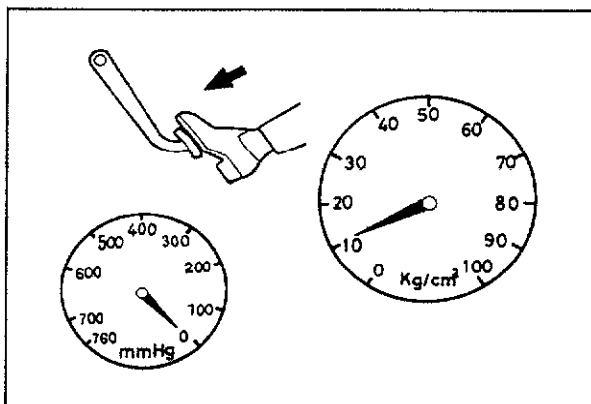

83U11X-068

## POWER BRAKE UNIT

### ON-VEHICLE INSPECTION

#### Method Using a Tester

Connect a pressure gauge, vacuum gauge and pedal depression force gauge as shown in the figure. After bleeding the air from the pressure gauge, conduct the test as described in the 3 steps below.

#### Note

Use commercially available gauges and pedal depression force gauge.

#### Checking for Vacuum Loss at Un-loaded Condition

1. Start the engine.
2. Stop the engine when the vacuum gauge reading reaches **500 mm-Hg (19.7 in-Hg)**.
3. Observe the vacuum gauge for 15 seconds. If the gauge shows **475—500 mm-Hg (18.7—19.7 in-Hg)**, the unit is serviceable.

#### Checking for Vacuum Loss at Loaded Condition

1. Start the engine.
2. Depress the brake pedal with a force of **196 N (20 kg, 44 lb)**.
3. With the brake pedal depressed, stop the engine when the vacuum gauge reading reaches **500 mm-Hg (19.7 in-Hg)**.
4. Observe the vacuum gauge for 15 seconds. If the gauge shows **475—500 mm-Hg (18.7—19.7 in-Hg)**, the unit is serviceable.

#### Checking for Hydraulic Pressure

1. If with the engine stopped (when the vacuum is **0 mm-Hg**), the relationship between the pedal force and fluid pressure is within the standard value range, the unit is serviceable.

Pedal force	Fluid pressure
196 N (20 kg, 44 lb)	1,373 kPa (14 kg/cm <sup>2</sup> , 199 psi) min

# 11 POWER BRAKE UNIT

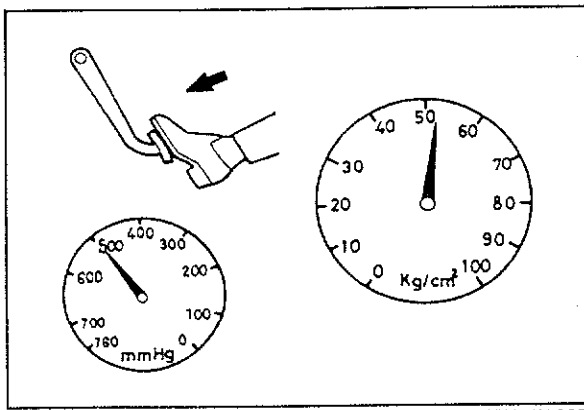

83U11X-069

2. Start the engine. Depress the brake pedal when the vacuum reaches **500 mm-Hg (19.7 in-Hg)**. If the relationship between the pedal force and fluid pressure is within the standard value range, the unit is good.

Pedal force	Fluid pressure
196 N (20 kg, 44 lb)	5,390 kPa (55 kg/cm <sup>2</sup> , 782 psi) min

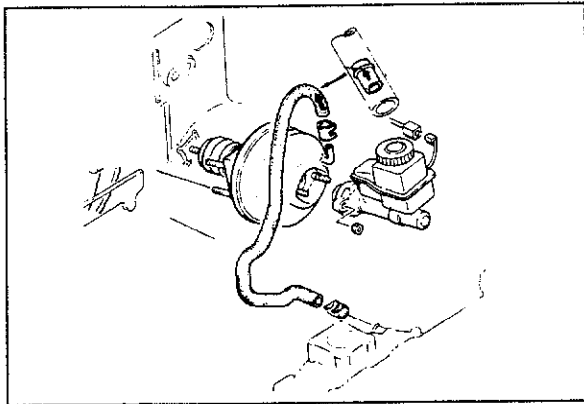

63U11X-042

## CHECK VALVE Inspection

1. Disconnect the vacuum hose (with internal check valve) from the engine side.
2. Apply suction and pressure to the hose from the engine side. Be sure air flows only toward the engine.

### Caution

**If the check valve is bad, replace the hose and valve.**

### Note

**The check valve is pressed into the vacuum hose, and there is an arrow on the hose surface to indicate the installation direction.**



### REMOVAL AND INSTALLATION

1. Remove the parts in the numbered sequence shown in the figure.
2. Install in the reverse order of removal.
3. Take the following steps after installation:
  - (1) Check and adjust the push rod and piston clearance.
  - (2) Add fluid and bleed the air.
  - (3) Check all parts for fluid leakage.
  - (4) Make an on-vehicle check of the unit.
  - (5) Check that the vacuum hose does not contact other parts.

#### Caution

Apply grease to the clevis pin.

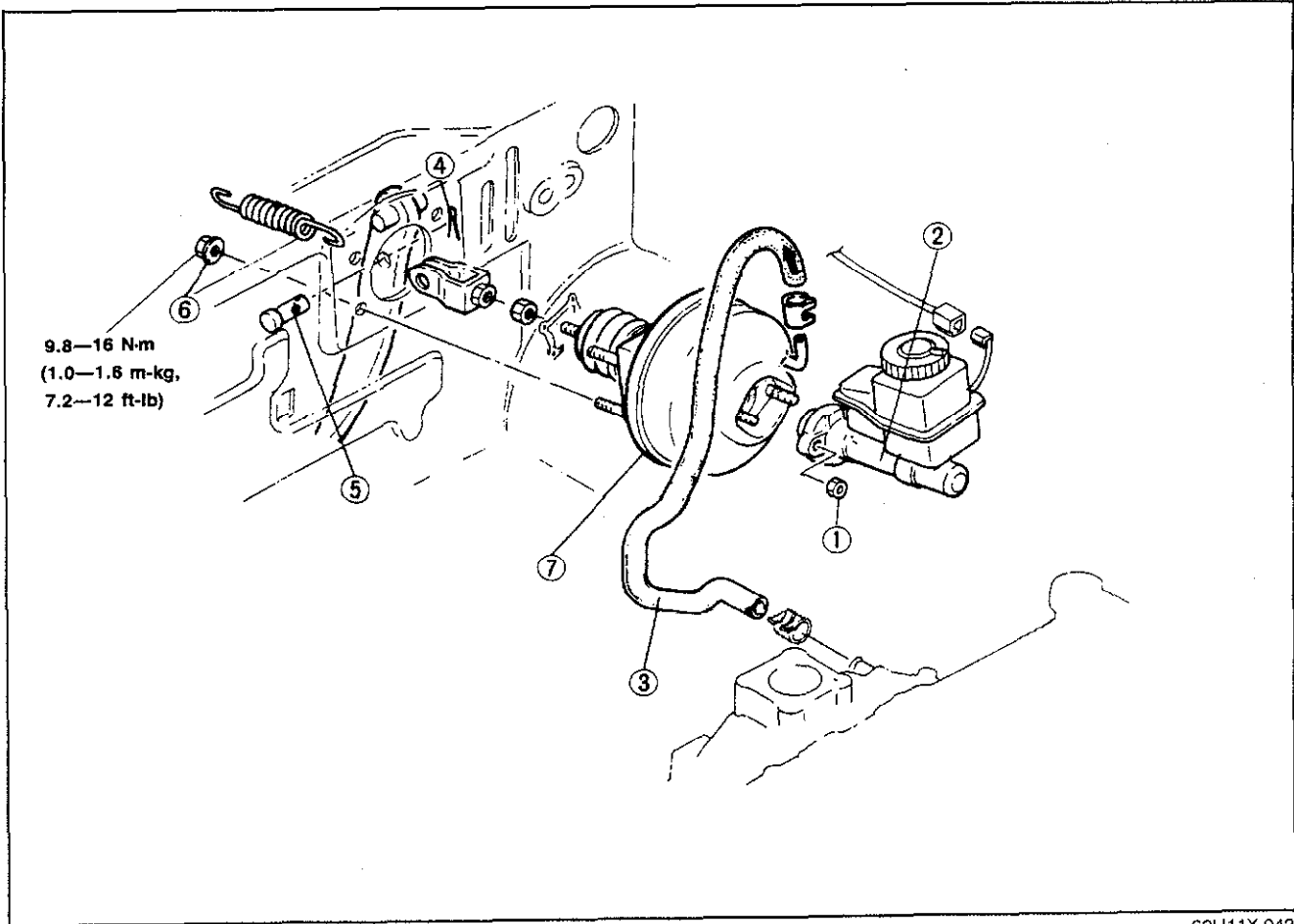

63U11X-043

- 1. Nut
- 2. Master cylinder
- 3. Vacuum hose

- 4. Cotter pin
- 5. Clevis pin
- 6. Nut

- 7. Power-brake unit

# 11 POWER BRAKE UNIT

## DISASSEMBLY

Disassemble the power-brake unit in the numbered sequence shown in the figure.

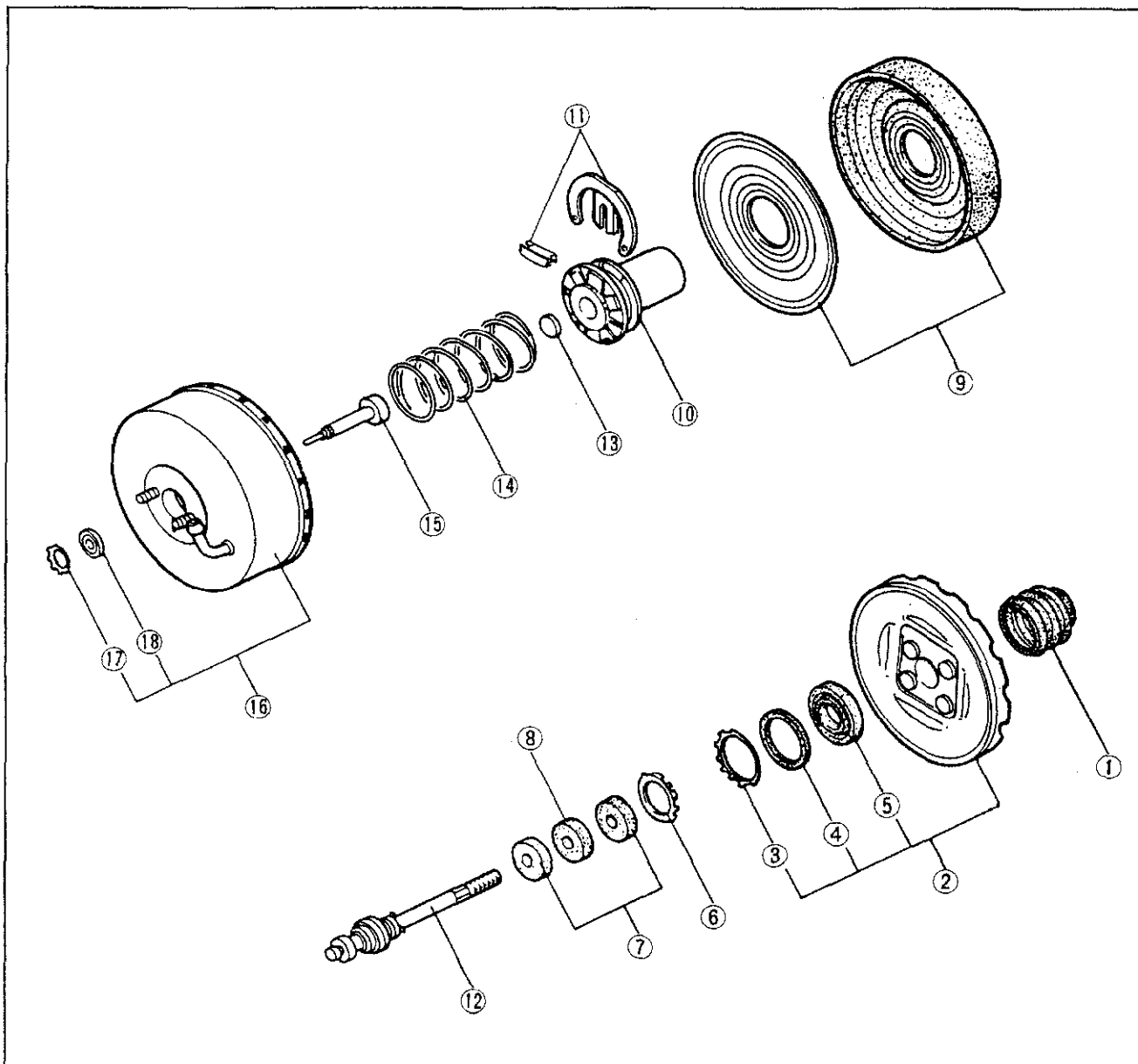

4BG11X-634

- |                        |                                    |                          |
|------------------------|------------------------------------|--------------------------|
| 1. Dust boot           | 7. Air filter                      | 13. Reaction disc        |
| 2. Rear shell assembly | 8. Air silencer                    | 14. Spring               |
| 3. Retainer            | 9. Diaphragm and plate             | 15. Push rod             |
| 4. Bearing             | 10. Power piston assembly          | 16. Front shell assembly |
| 5. Dust seal           | 11. Retainer key and stopper       | 17. Retainer             |
| 6. Retainer            | 12. Valve rod and plunger assembly | 18. Seal                 |

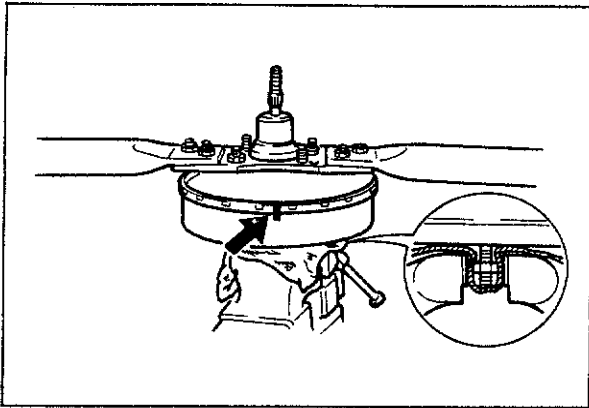

63U11X-044

### Rear Shell

1. Before separating the front and rear shells, make mating marks to be used for reassembly.
2. Fit a wrench onto the studs of the rear shell, rotate the rear shell counterclockwise to unlock.

### Caution

**The rear shell is spring loaded; loosen it carefully.**

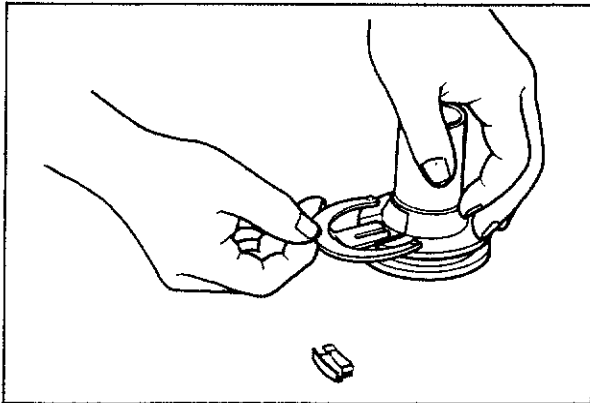

4EG11X-034

### Retainer Key

Press the valve rod in to remove the valve retainer key.

Remove the valve rod and plunger assembly.

### Caution

**The valve rod and plunger must be serviced as an assembly.**

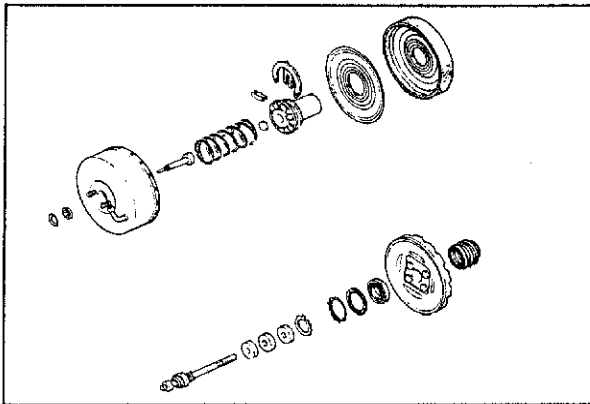

63U11X-045

### INSPECTION

1. Inspect all rubber parts. Wipe free of fluid and carefully inspect all rubber parts for cuts, nicks, or other damage.
2. Check the power piston for cracks, distortion, chipping, or damaged seats.
3. Inspect the reaction disc rubber for deterioration.
4. Check that the seats of the valve rod and plunger are smooth and free of nicks and dents. Replace if defective.
5. Inspect the front and rear shells for scratches, scores, pits, dents, or other damage.
6. Check the diaphragm for cuts or other damage.

### ASSEMBLY

1. Coat the parts shown in the figure with silicon grease.

- (1) Entire surface of reaction disc
- (2) Dust seal lip
- (3) Push rod
- (4) Diaphragm to shell contacting surfaces
- (5) Power piston
- (6) Valve plunger oil seal

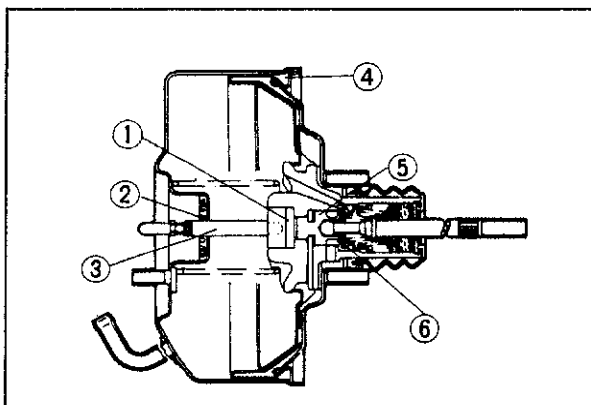

4BG11X-636

# 11 POWER BRAKE UNIT

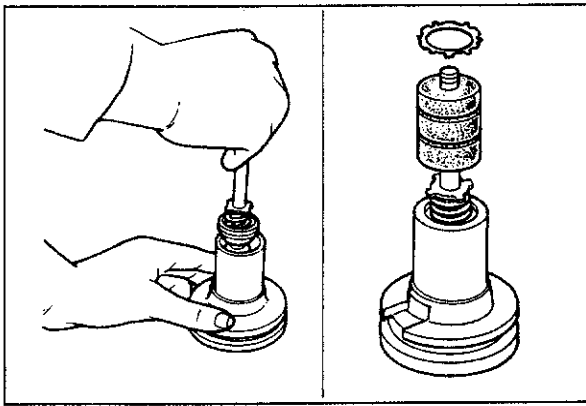

4BG11X-637

2. Install the valve rod and plunger assembly.
3. Install the air filter and silencer.
4. Install the retainer.

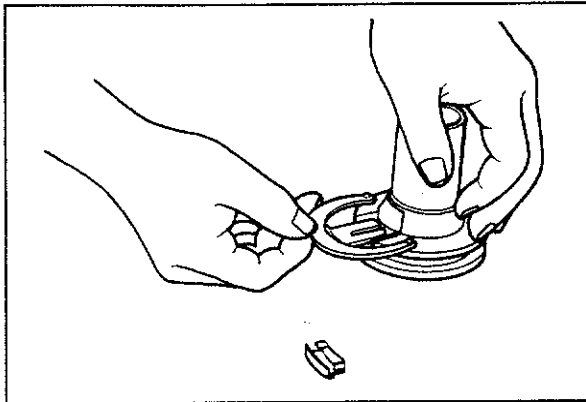

4BG11X-638

5. Install the retainer key.

**Caution**  
Push down the valve rod, align the groove in the valve plunger with the slot of the power piston, and insert the valve retainer key.

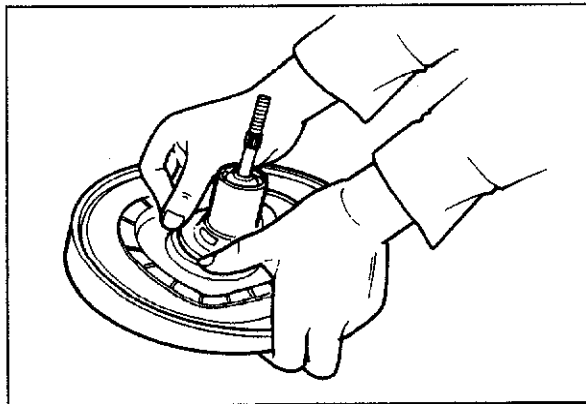

4BG11X-639

6. Connect the diaphragm to the power piston and plate.

**Caution**  
Make certain that the diaphragm is well seated in the groove.

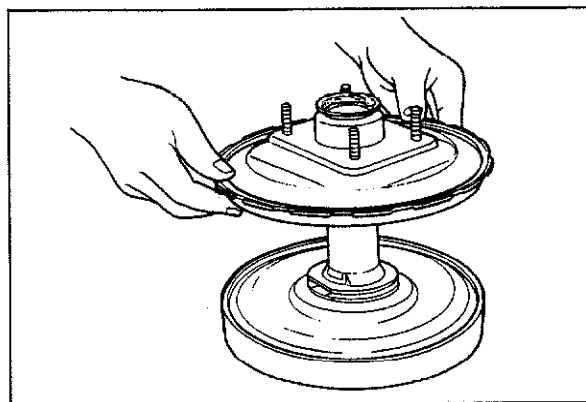

63U11X-046

7. Assemble the rear shell assembly.

**Caution**  
Carefully guide the tube end of the power piston through the seal in the rear shell.

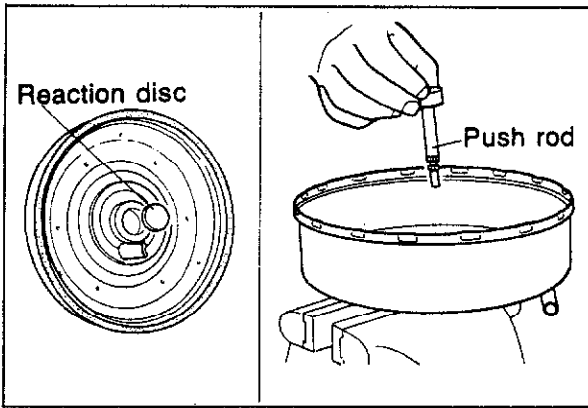

63U11X-047

8. Push the reaction disc into the power piston with the push rod.

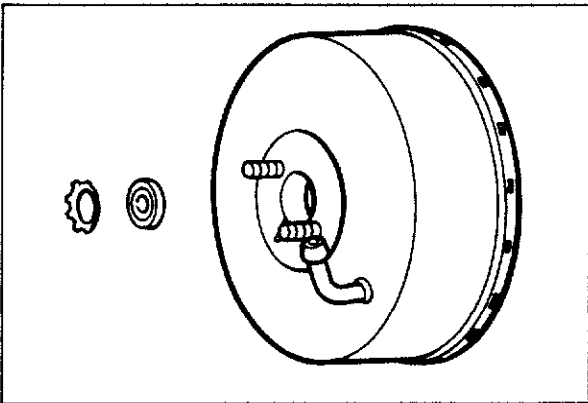

63U11X-048

9. Put the dust seal and retainer into the front shell.

**Caution**

**Place the front shell assembly in a vise, to complete the following operations and to compress the spring.**

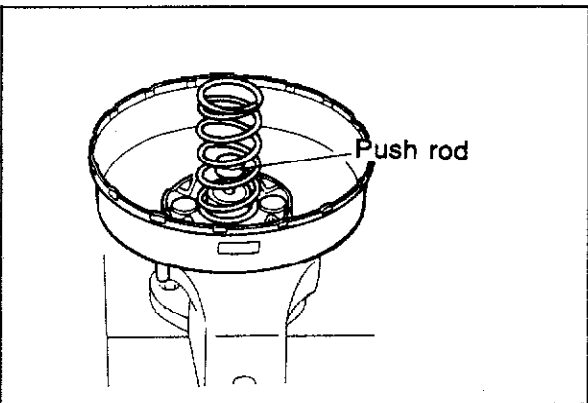

63U11X-049

10. Install the push rod.
11. Install the return spring.

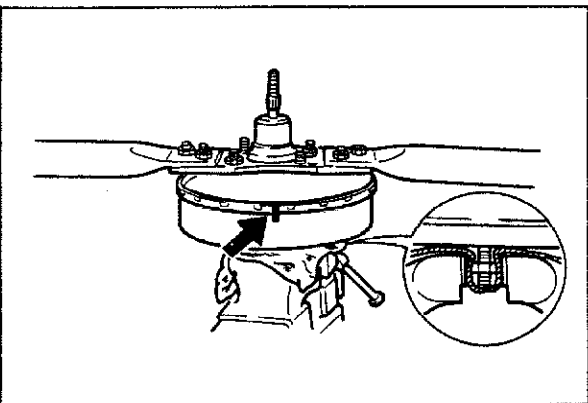

63U11X-050

12. Press the rear shell down and rotate it clockwise until the mating marks are aligned by using a suitable wrench.
13. Put the dust boot on to the rear shell.

# 11 FRONT DISC BRAKE

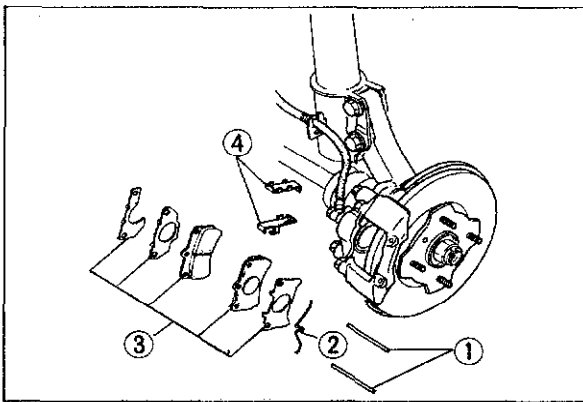

83U11X-016

## FRONT DISC BRAKE

### REPLACEMENT OF DISC PAD

#### Caution

Replace the left and right pads at the same time.

1. Jack up the front of the vehicle, and support it with safety stands.
2. Remove the wheels.
3. Remove the disc pad in the sequence shown in the figure.

#### Warning

Asbestos dust is hazardous to one's health. Do not blow away the dust with compressed air.

4. Install in the reverse order of removal.

#### Note

Use the SST (49 0221 600C) to push the piston into the cylinder.

### REMOVAL AND INSTALLATION

1. Jack up the front of the vehicle and support it with safety stands.
2. Remove the wheels and remove the front disc brakes in the numbered sequence shown in the figure.
3. Install in the reverse order of removal.

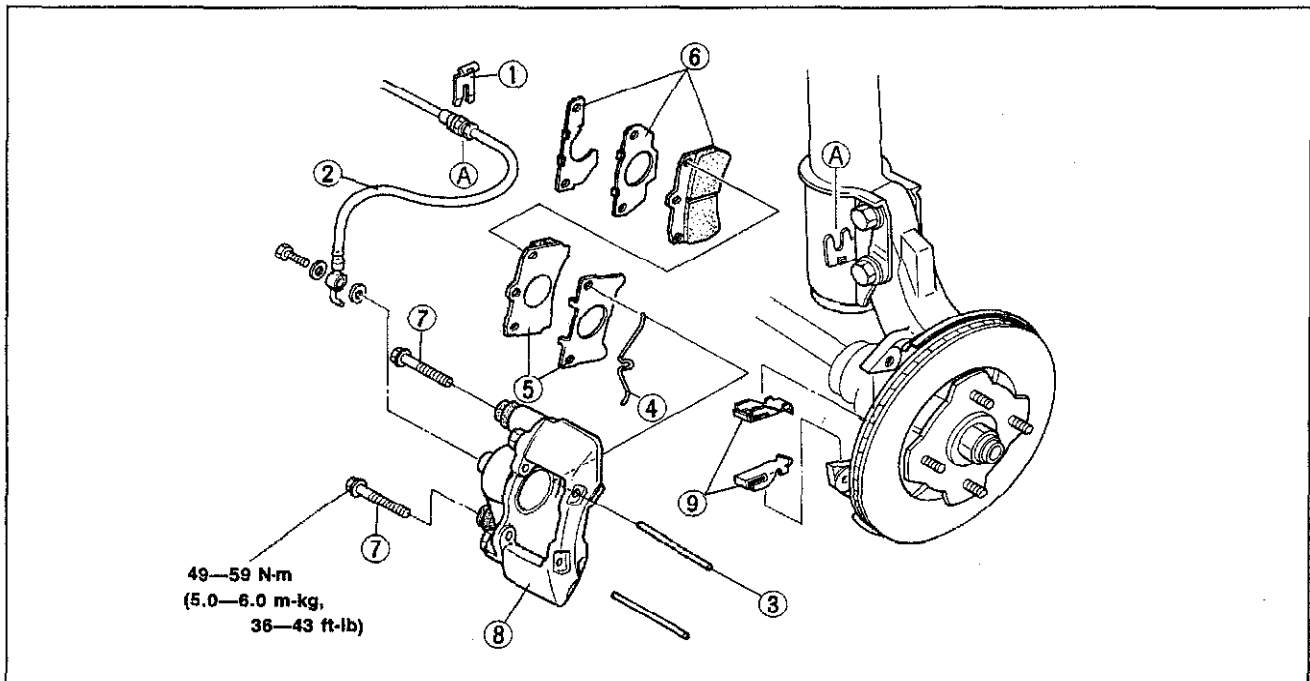

83U11X-070

1. Clip
2. Flexible hose
3. Pad pin

4. Pad spring
5. Outer pad and shim
6. Inner pad and shim

7. Bolt
8. Caliper
9. Guide plate

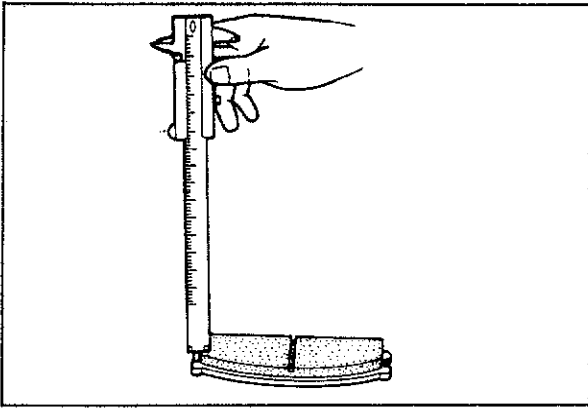

83U11X-017

## INSPECTION

Inspect and if necessary replace parts.

### Disc Pad

1. Oil or grease on facing
2. Abnormal wear or cracks
3. Deterioration or damage by heat
4. Remaining lining thickness

**Thickness limit: 2 mm (0.08 in) min.**

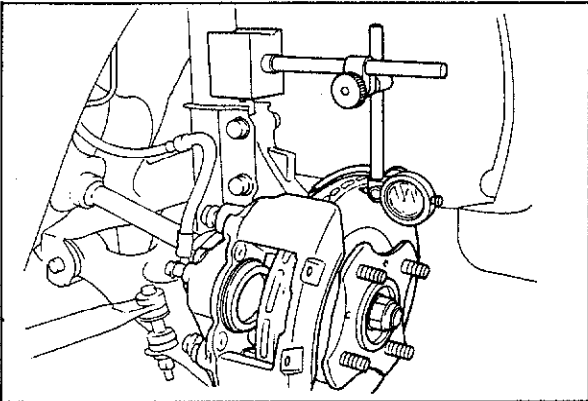

63U11X-057

### Disc Plate

1. Runout

**Runout limit: 0.1 mm (0.004 in)**

### Caution

- a) There must be no wheel bearing play.
- b) The point of measurement is the outermost diameter of the contact surface of the disc pad.

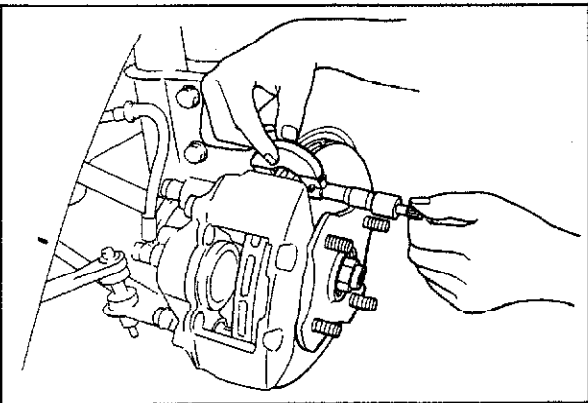

63U11X-058

2. Wear or damage

### Thickness

**Standard: 18 mm (0.71 in)**

**Limit: 16 mm (0.63 in)**

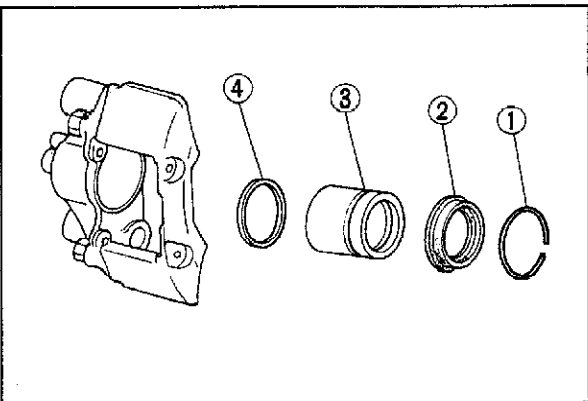

83U11X-071

## DISASSEMBLY

Disassemble the caliper in the numbered sequence shown in the figure.

1. Retaining ring
2. Dust seal
3. Piston
4. Piston seal

# 11 FRONT DISC BRAKE

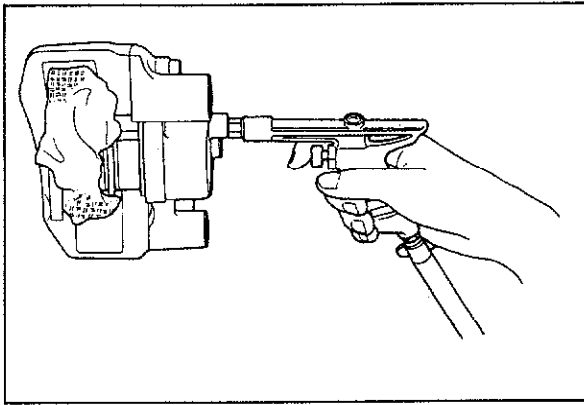

63U11X-055

## Piston

Place a piece of wood in the caliper, and then blow compressed air through the flexible hose connection hole to force the piston out of the caliper.

## Caution

**Blow the compressed air a little at a time to prevent the piston from jumping out.**

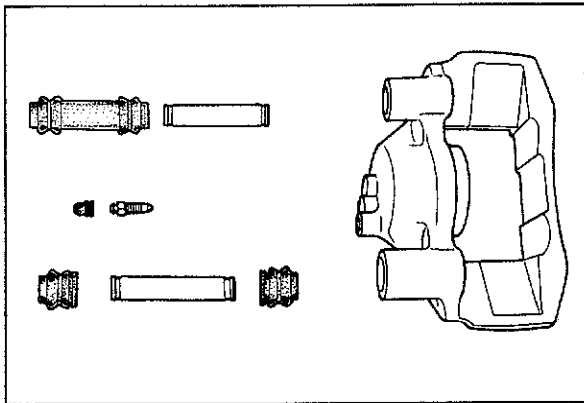

83U11X-018

## INSPECTION

1. Cylinder and piston for wear or rust.
2. Caliper body for damage or cracks.
3. Guide pin bushing and dust cover for damage or poor sealing.

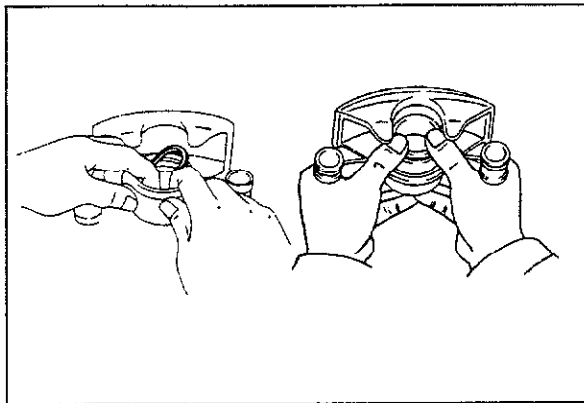

63U11X-059

## ASSEMBLY

1. Coat the piston seal with the pink grease (supplied in the seal kit) and install it to the caliper.

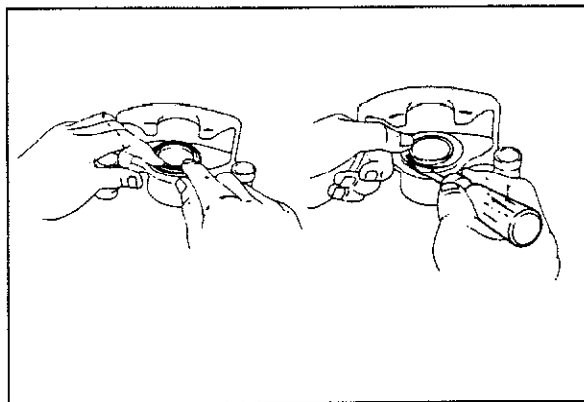

4BG11X-660

2. Coat the piston and the cylinder with brake fluid, and fit the piston straight into the cylinder.
3. Install the dust seal.



## REAR DRUM BRAKE

### REMOVAL

1. Loosen the wheel lug nuts.
2. Release the parking brakes.
3. Jack up the rear of the vehicle and support it with safety stands.
4. Remove the wheels.
5. Remove in the sequence shown in the figure.

### Caution

Do not damage the wheel cylinder dust boots when removing the brake shoes.

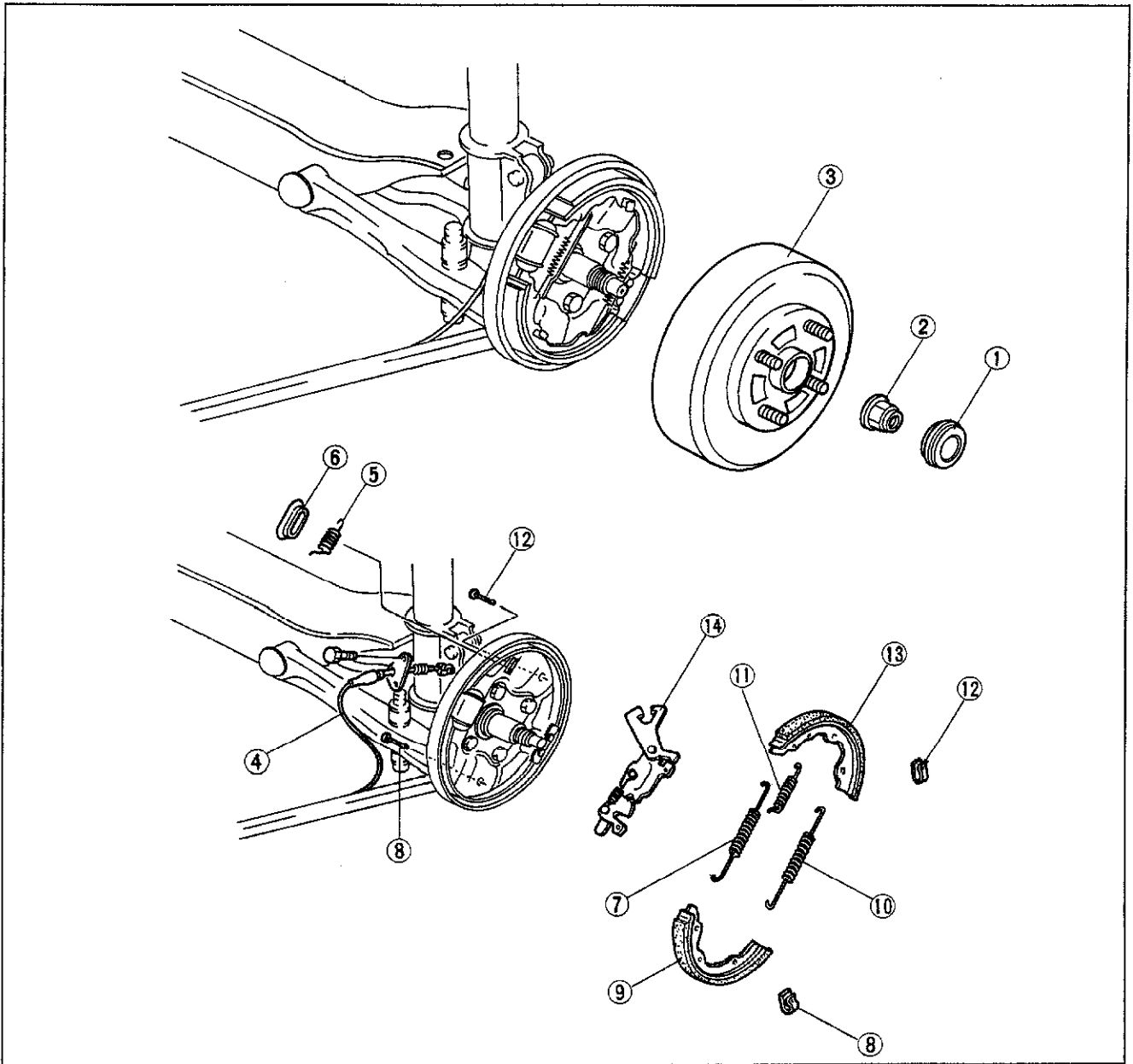

83U11X-089

1. Hub cap
2. Locknut
3. Brake drum
4. Parking cable
5. Return spring

6. Dust cover
7. Return spring (upper)
8. Hold pin and spring
9. Brake shoe (leading side)
10. Return spring (lower)

11. Anti-rattle spring
12. Hold pin and spring
13. Brake shoe (trailing side)
14. Operating lever assembly

# 11 REAR DRUM BRAKE

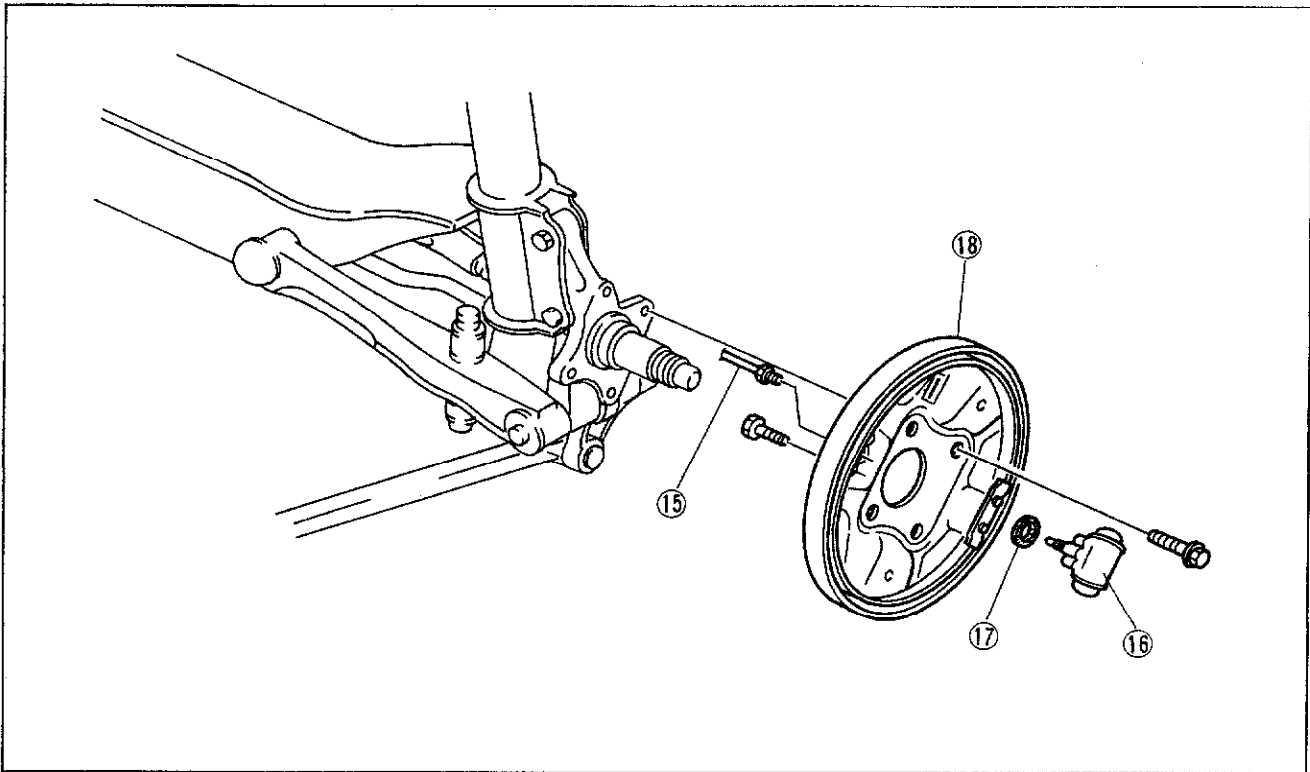

83U11X-090

- 15. Brake pipe
- 16. Wheel cylinder assembly

- 17. Gasket
- 18. Backing plate

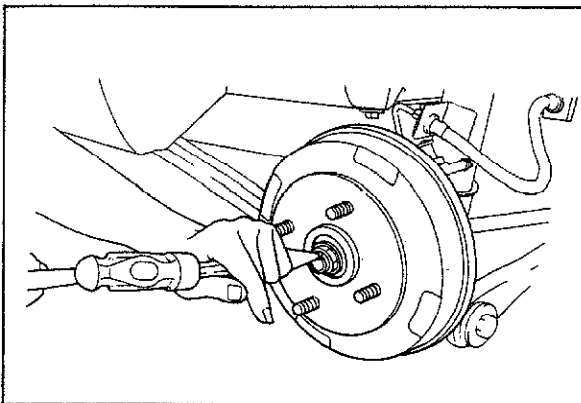

83U11X-091

## Locknut

Uncrimp the locknut, and remove it.

## Caution

**Do not reuse the locknut.**

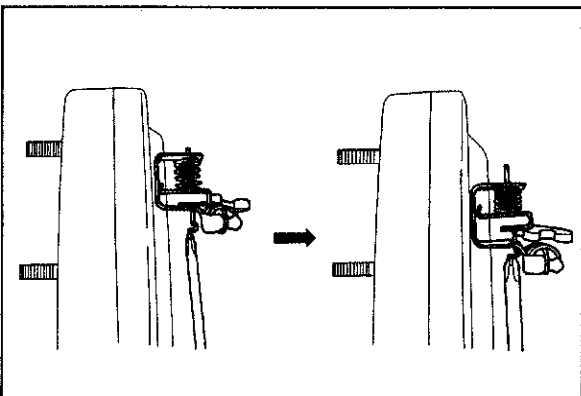

83U11X-092

## Brake Drum

If the drum is difficult to remove, push the operating lever stopper (at backing plate) upward to release the operating lever and increase shoe clearance.

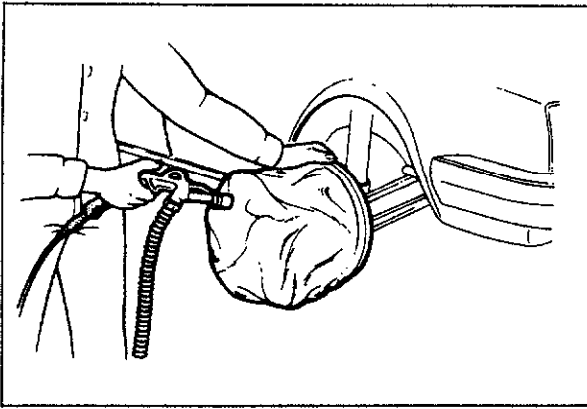

83U11X-093

## Cleaning of Drum Brake Assembly

Use a vacuum cleaner or equivalent to clean the brake assembly

### Warning

**Asbestos dust is hazardous to one's health. When cleaning the brake assembly, do not use compressed air or a brush.**

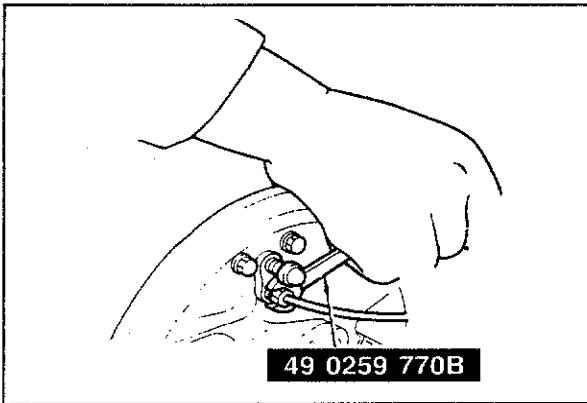

83U11X-094

## Brake Pipe

Disconnect or connect the brake pipe with the **SST**.

### Caution

**Brake fluid will damage painted surfaces. If it does get on a painted surface, wipe it off immediately.**

# 11 REAR DRUM BRAKE

## DISASSEMBLY AND ASSEMBLY OF WHEEL CYLINDER

1. Disassemble in the sequence shown in the figure.
2. Assemble in the reverse order of disassembly.

### Caution

Do not damage the piston or cylinder. Do not let foreign material in the cylinder.

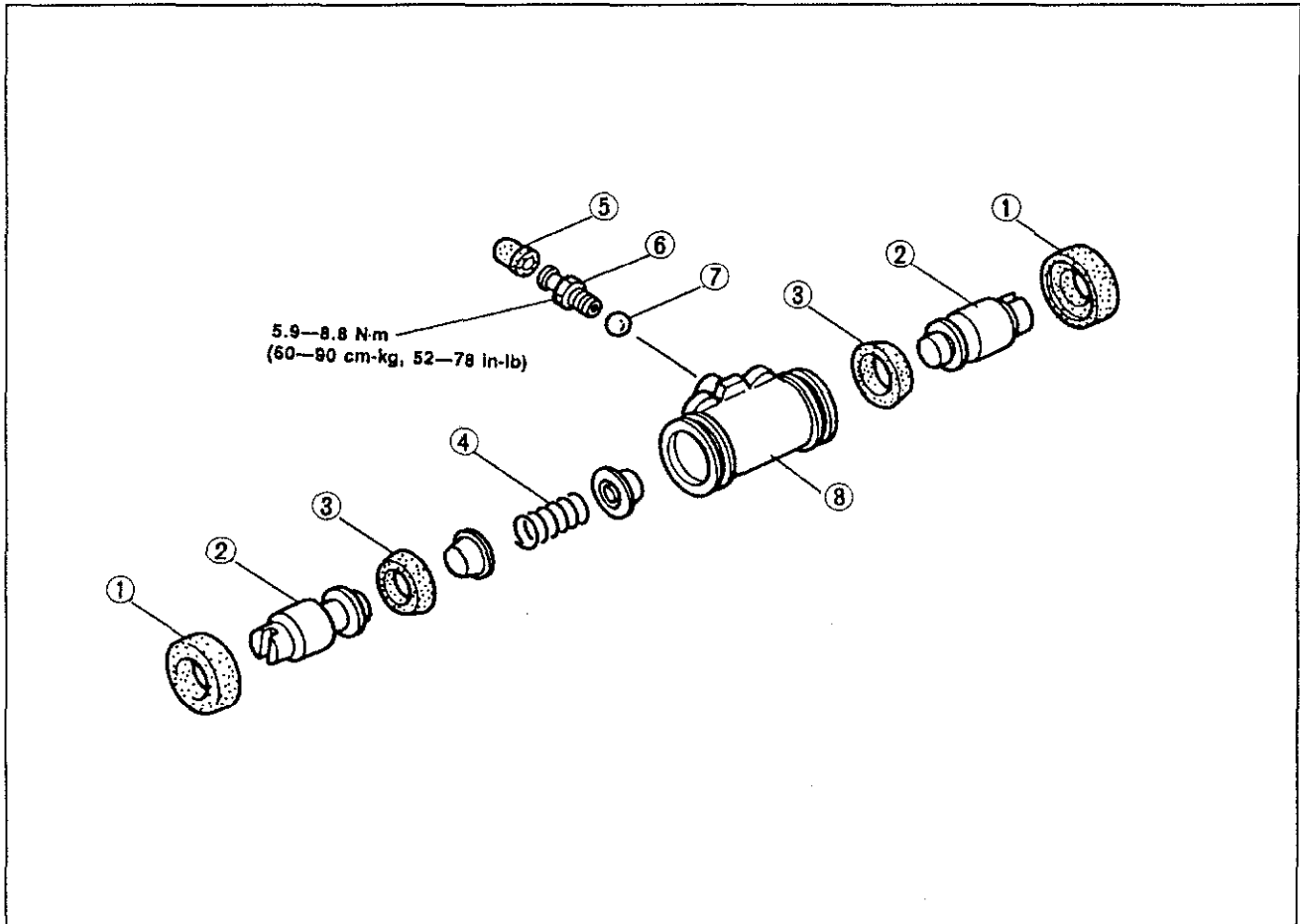

83U11X-095

- |               |                  |                        |
|---------------|------------------|------------------------|
| 1. Dust boot  | 4. Spring        | 7. Steel ball          |
| 2. Piston     | 5. Rubber cap    | 8. Wheel cylinder body |
| 3. Piston cup | 6. Bleeder screw |                        |

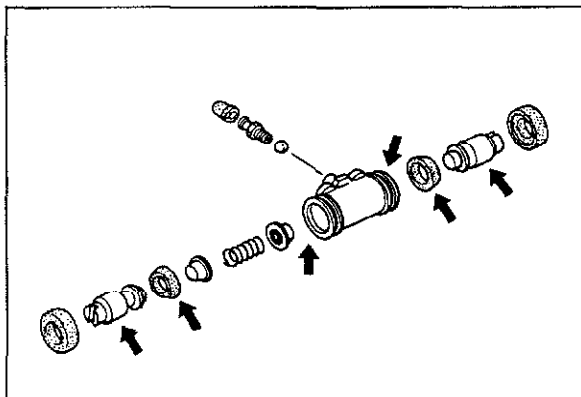

83U11X-096

### Application of Grease

Before assembly, apply brake fluid to the following parts:

1. Piston cup
2. Cylinder inner wall
3. Piston

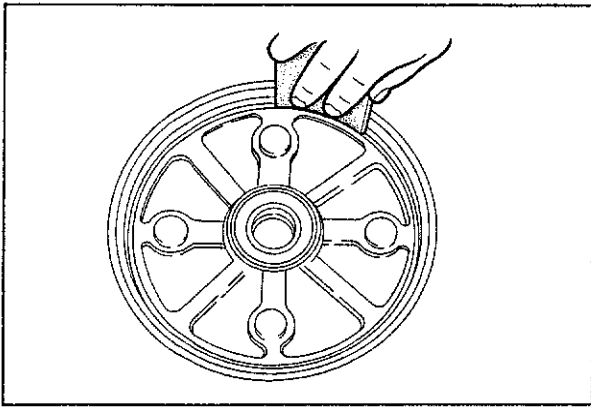

86U11X-117

## INSPECTION

Check the following and repair or replace any faulty parts.

1. Scratches, uneven or abnormal wear inside drum

### Note

**Repair by sanding if the problem is minor.**

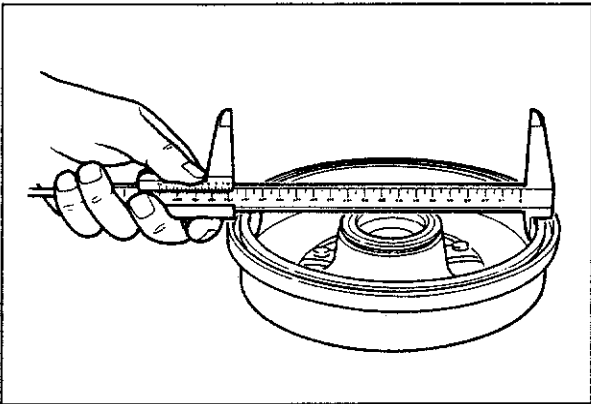

83U11X-072

2. Drum inner diameter

**Diameter: 200 mm (7.87 in)**

**Maximum: 201 mm (7.91 in)**

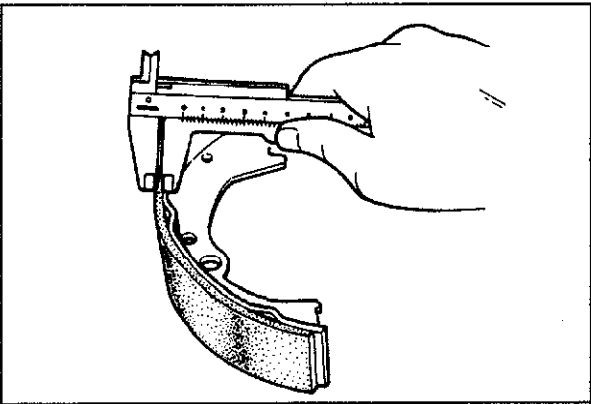

86U11X-119

3. Peeling, cracking, or extremely uneven wear of lining
4. Lining wear

**Thickness: 1.0 mm (0.04 in) min.**

### Caution

**When replacing the shoe assembly, replace the left and right shoes at the same time as a set.**

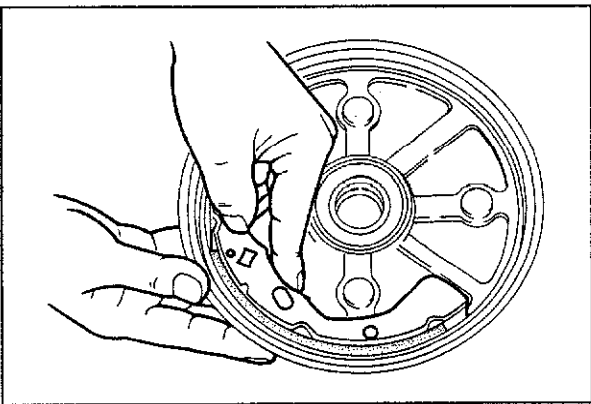

86U11X-120

5. Fit of drum and lining
  - (1) Apply chalk to the inside of the drum.
  - (2) Rub the shoe against the drum.
  - (3) Check for the fitness of the drum and lining and replace the brake shoe or repair the brake drum.
  - (4) After the check, wipe the chalk off.

# 11 REAR DRUM BRAKE

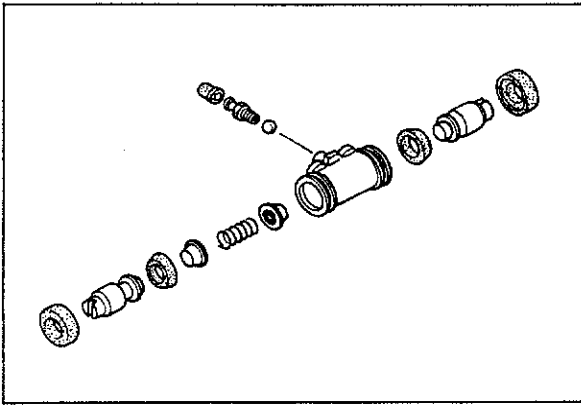

83U11X-097

6. Weak or broken spring
7. Worn, rusted, or damaged wheel cylinder

## INSTALLATION

1. Install in the reverse order of removal.
2. After installation:
  - (1) Add brake fluid and bleed air. (Refer to page 11—11.)
  - (2) Adjust the parking brake lever stroke. (Refer page to 11—8.)
  - (3) Depress the brake pedal a few times and check that the rear brakes do not drag while rotating the wheel.

## Torque specification

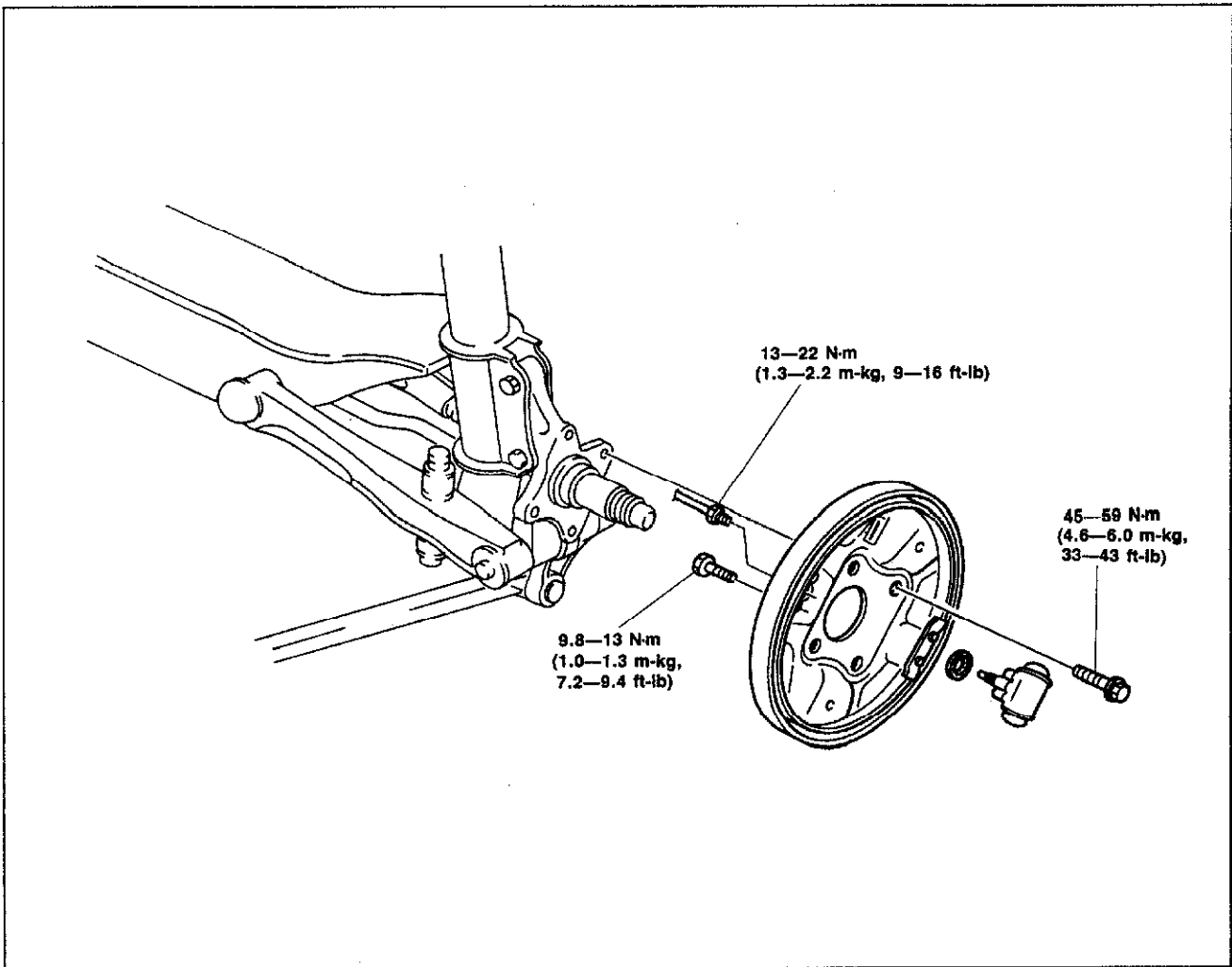

83U11X-073

## Torque specification

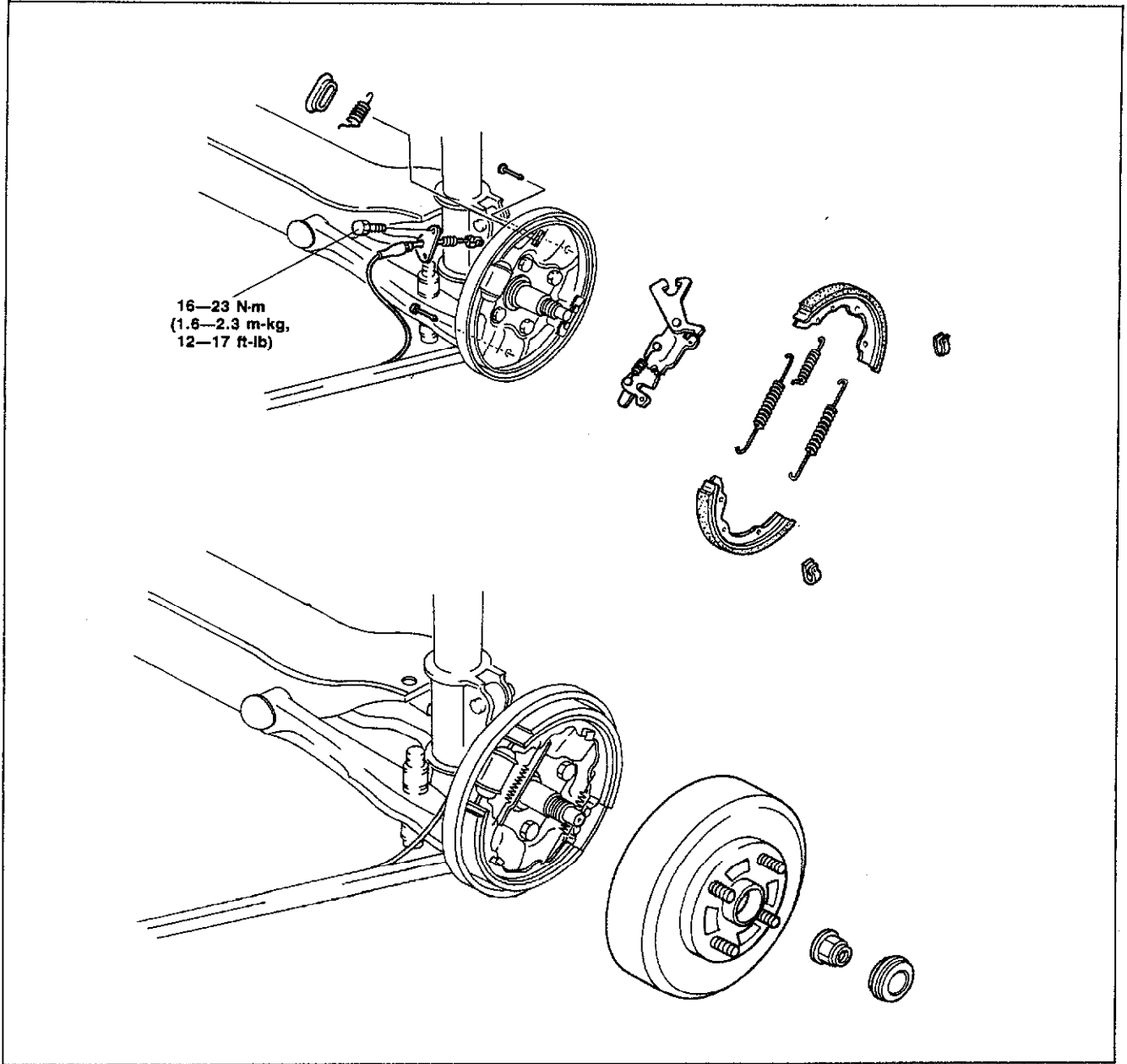

86U11X-122

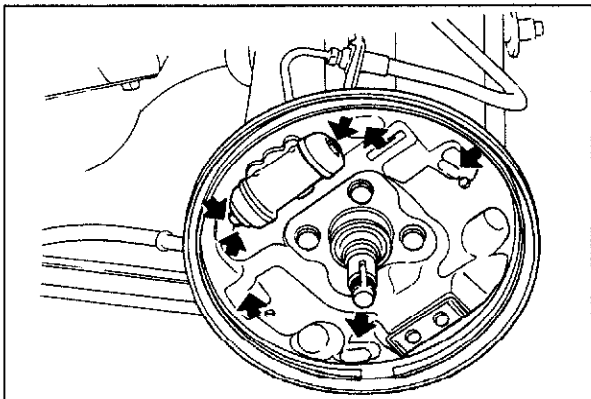

83U11X-098

### Brake Shoe

1. Apply grease to the following points:
  - (1) Shoe and cylinder contact points
  - (2) Shoe anchor points
  - (3) Projections of backing plate

# 11 REAR DRUM BRAKE

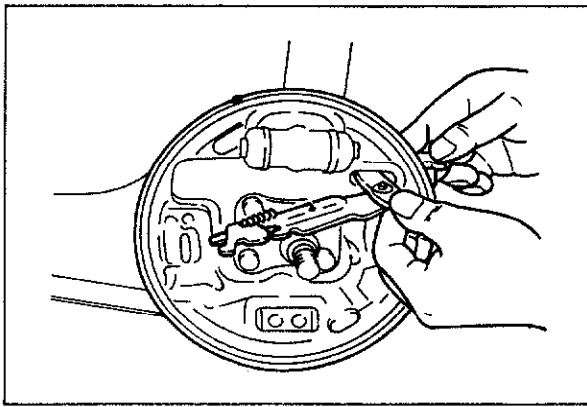

86U11X-124

2. Install the operating lever assembly through the backing plate.
3. Install the return spring to the back plate (reverse side) and the operating lever.

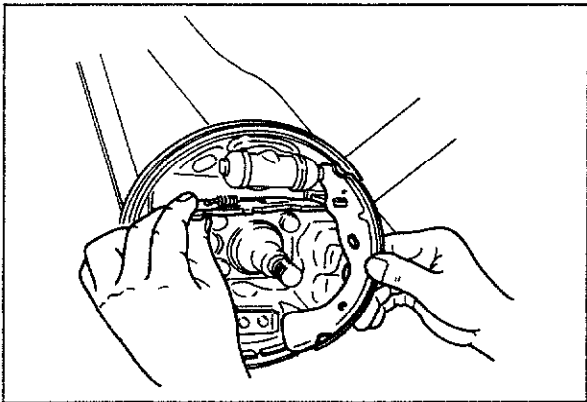

86U11X-125

4. Install the shoe (trailing side) to the operating lever, then to the wheel cylinder and anchor plate.
5. Fix the shoe with the hold spring and hold pin.
6. Install the anti-rattle spring.

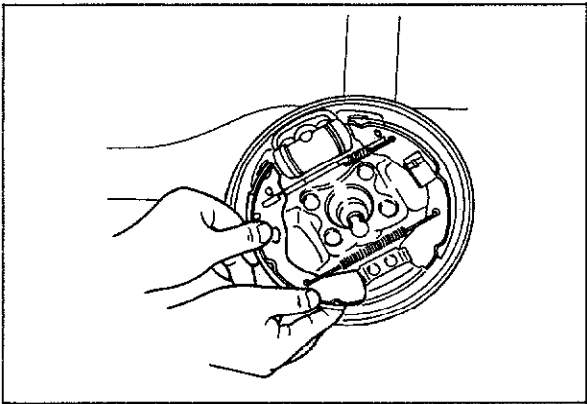

86U11X-126

7. Install the return spring (lower) to the shoes (trailing side and leading side).
8. Install the shoe (leading side) to the operating lever, then to the wheel cylinder and anchor plate.
9. Fix the shoe with the hold spring and hold pin.

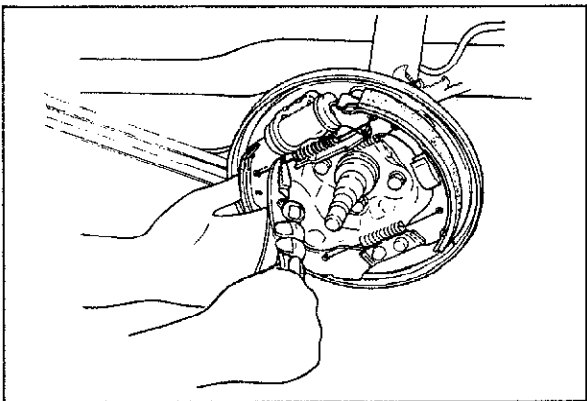

83U11X-074

10. Install the return spring (upper).



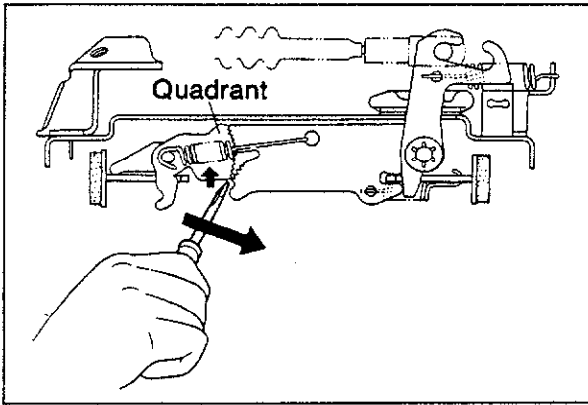

83U11X-075

### Brake Drum

Move the quadrant against the backing plate with a screwdriver to increase the shoe clearance.

### Note

The shoe clearance will be automatically adjusted by applying parking brakes.

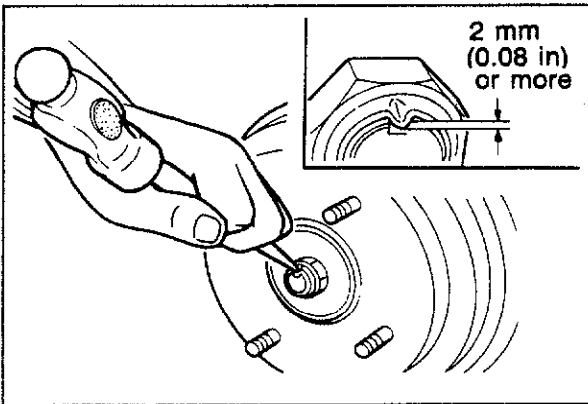

83U11X-076

### Locknut

1. Temporarily tighten a new locknut.
2. Adjust the bearing preload. (Refer to Section 9)
3. Securely stake the locknut to the spindle groove.

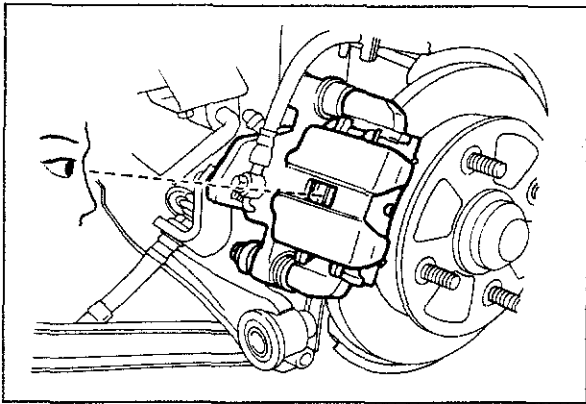

86U11X-083

## REAR DISC BRAKE

### SIMPLE INSPECTION OF DISC PAD WEAR

1. Loosen the rear wheel lug nuts.
2. Jack up the rear of the vehicle and support it with safety stands.
3. Remove the wheels.
4. Lock through the caliper inspection hole and check that the remaining thickness of the pad is **1 mm (0.04 in) min.**

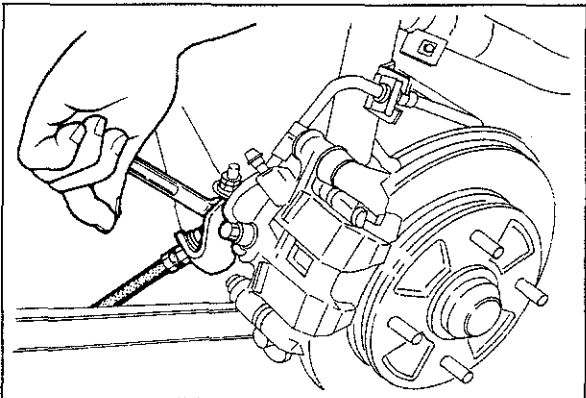

83U11X-077

### REPLACEMENT OF DISC PAD

#### Caution

**Replace the left and right pads at the same time.**

1. Loosen the wheel lug nuts.
2. Release the parking brakes.
3. Jack up the rear of the vehicle and support it with safety stands.
4. Remove the wheels.
5. Remove the parking brake cable and bracket.
6. Remove the lower mounting bolt, then pivot the caliper and support it.
7. Remove the V-spring.
8. Remove the pads and shims.

#### Warning

**Asbestos dust is hazardous to one's health. Do not blow away brake dust with compressed air.**

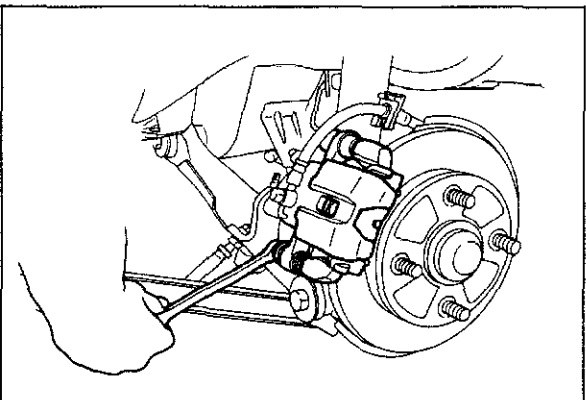

83U11X-078

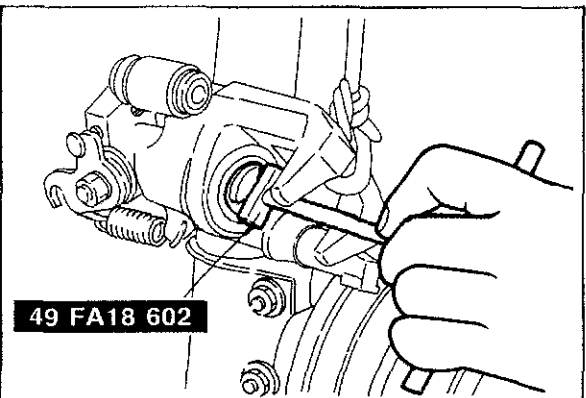

83U11X-099

9. Apply the grease supplied in the pad attachment set to the new shims; then attach them to the new pads.
10. Turn the piston fully inward by rotating the **SST** clockwise. Align the piston groove with the pad pin of the inner pad.
11. Install the pads and shims to the mounting support.
12. Install the pad clip.

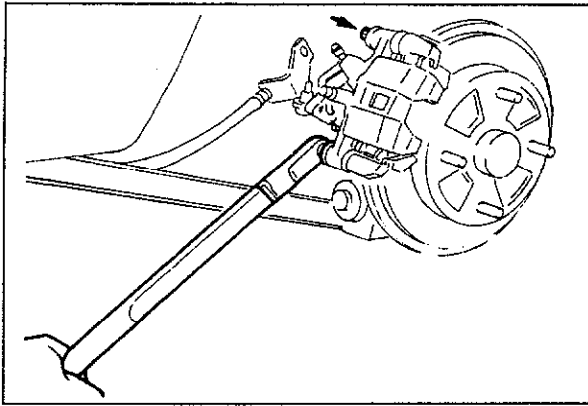

83U11X-079

13. Lower the caliper assembly onto the mounting support.
14. Tighten the mounting bolt to the specified torque.

**Tightening torque:**

**16—24 N·m  
(1.6—2.4 m·kg, 12—17 ft·lb)**

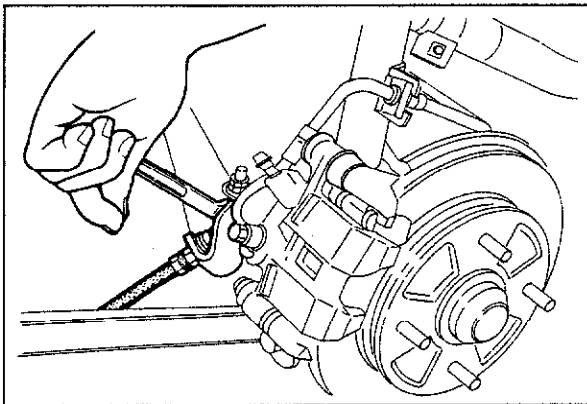

83U11X-080

15. Connect the parking cable and bracket.

**Tightening torque:**

**45—67 N·m (4.6—6.8 m·kg, 33—49 ft·lb)**

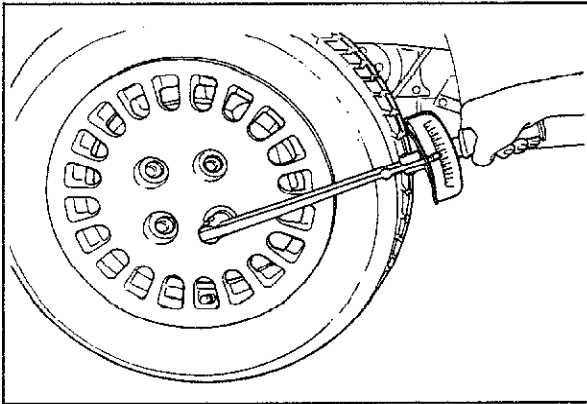

86U11X-089

16. Mount the wheels.
17. Apply the brakes a few times; then check that the brakes do not drag excessive while turning the wheels.
18. Lower the vehicles.
19. Tighten the wheel lug nuts.

**Tightening torque:**

**88—118 N·m (9—12 m·kg, 65—87 ft·lb)**

# 11 REAR DISC BRAKE

## REMOVAL

1. Loosen the wheel lug nuts.
2. Release the parking brakes.
3. Jack up the rear of the vehicle and support it with safety stands.
4. Remove the wheels.
5. Remove in the sequence shown in the figure.

## Warning

Asbestos dust is hazardous to one's health. Do not blow away brake dust with compressed air.

## Caution

Brake fluid will damage painted surfaces. If it does get on a painted surface, wipe it off immediately.

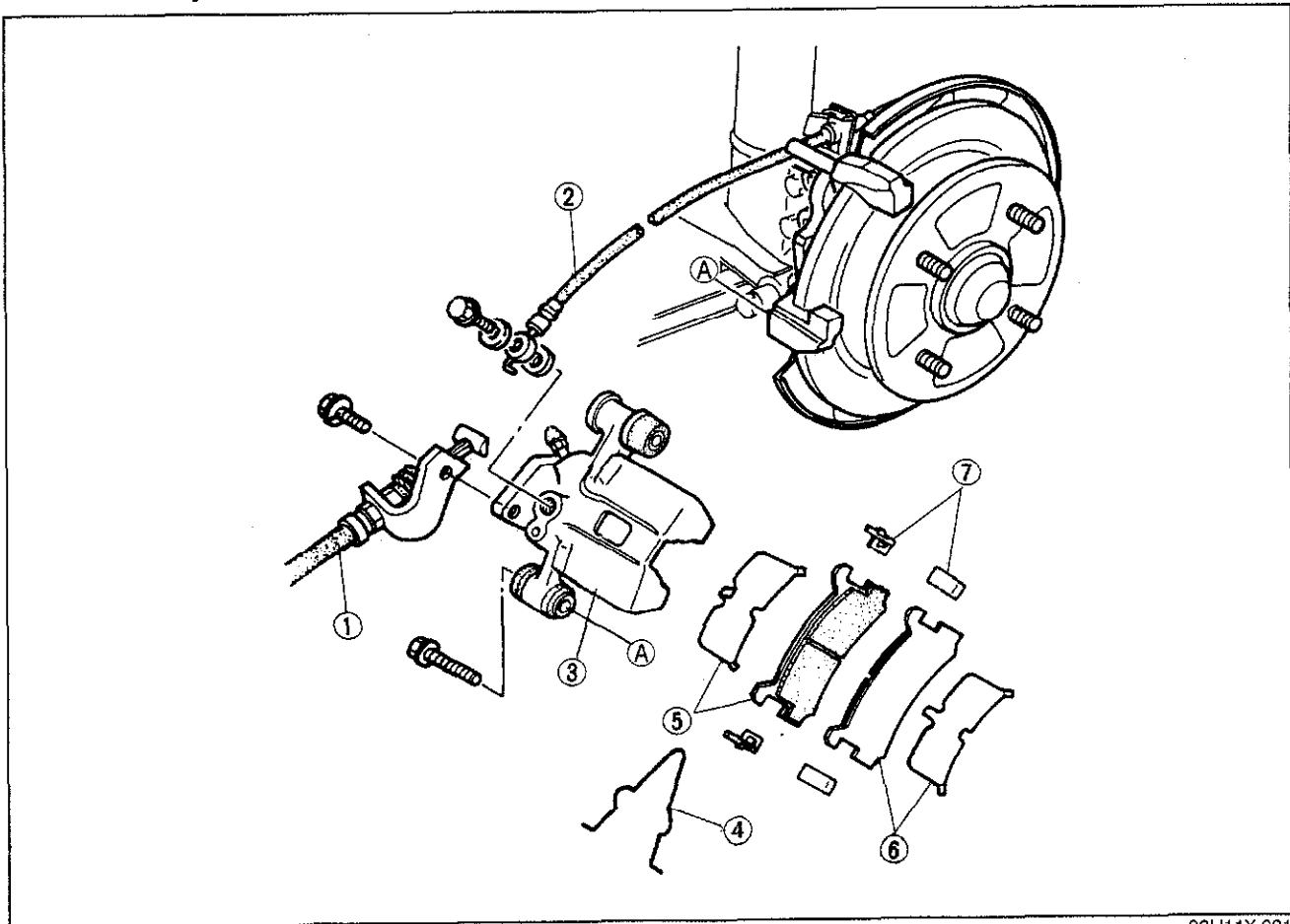

83U11X-081

1. Parking cable and bracket
2. Flexible hose
3. Caliper

4. V-spring
5. Inner pad and shim
6. Outer pad and shim

7. Guide plate

## DISASSEMBLY AND ASSEMBLY

1. Disassemble the caliper in the sequence shown in the figure.
2. Assemble in the reverse order of disassembly.

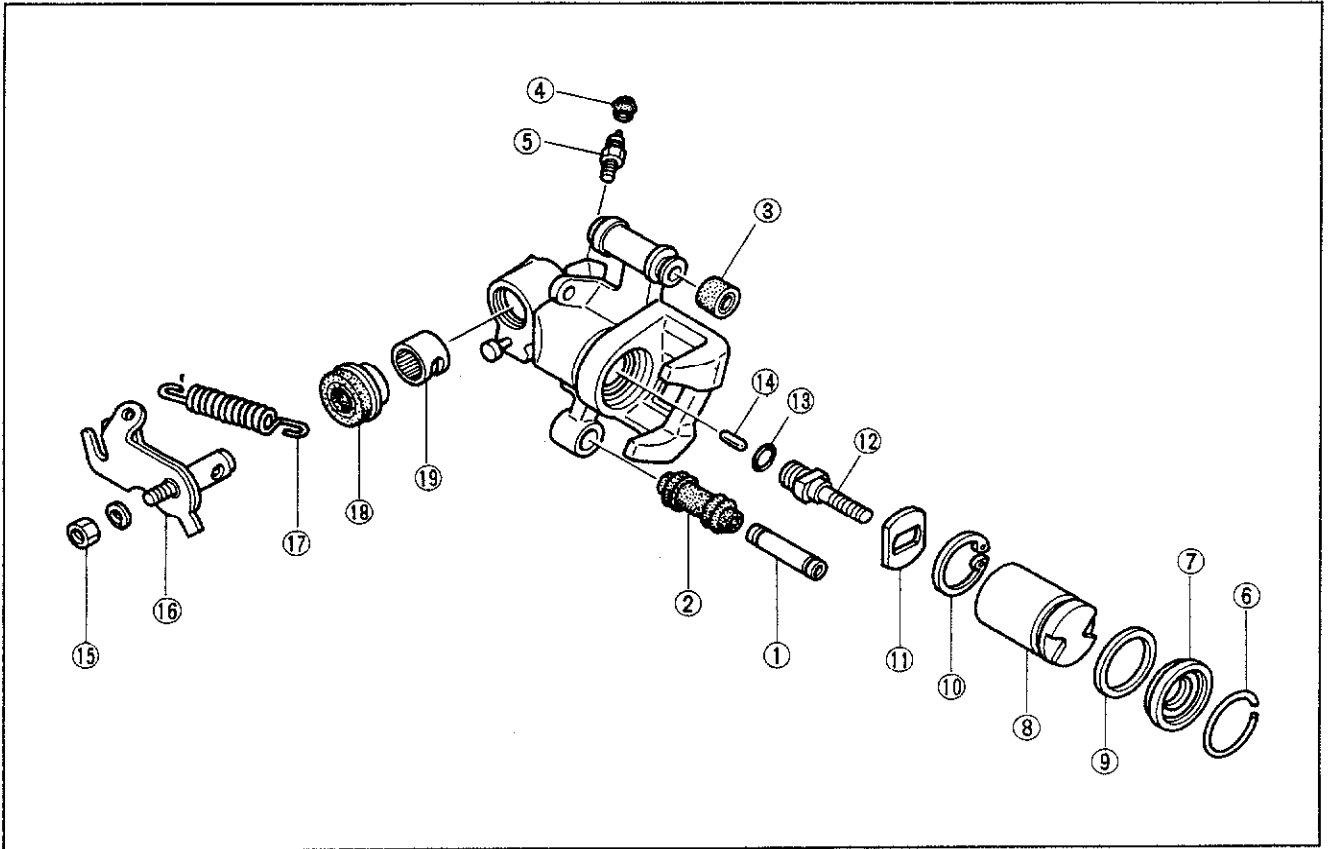

83U11X-082

- |                   |                      |                     |
|-------------------|----------------------|---------------------|
| 1. Sleeve pin     | 8. Piston            | 15. Nut             |
| 2. Boot           | 9. Piston seal       | 16. Operating lever |
| 3. Bushing        | 10. Snap ring        | 17. Return spring   |
| 4. Cap            | 11. Stopper          | 18. Boot            |
| 5. Bleeder screw  | 12. Adjuster spindle | 19. Needle bearing  |
| 6. Retaining ring | 13. "O" ring         |                     |
| 7. Dust seal      | 14. Connecting link  |                     |

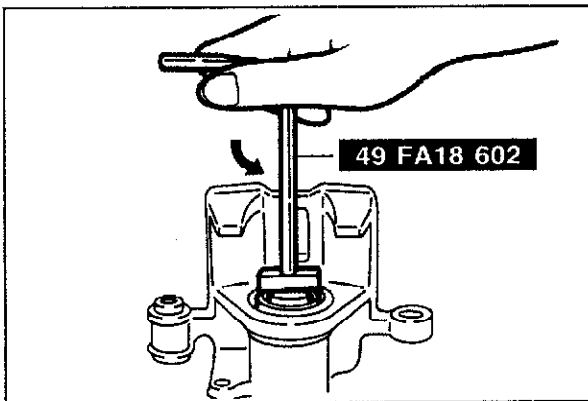

83U11X-083

### Piston

Remove the piston with the SST.

### Note

The piston can be removed by turning the SST counterclockwise.

# 11 REAR DISC BRAKE

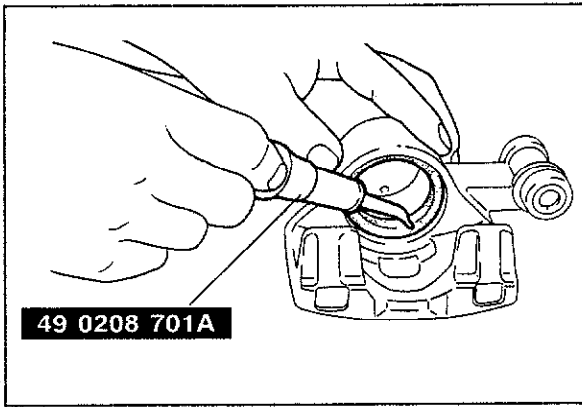

83U11X-100

## Piston Seal

Remove the piston seal with the **SST**.

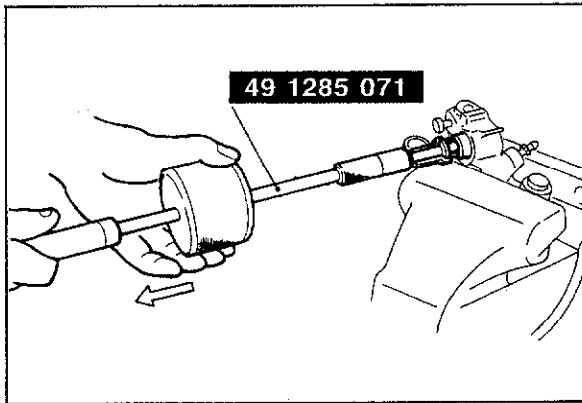

83U11X-101

## Needle Bearing

1. Secure the caliper in a vise.

### Caution

**Insert a soft, protective material (such as copper plates) in the jaws of the vise.**

2. Remove the needle bearing from the caliper with the **SST**.

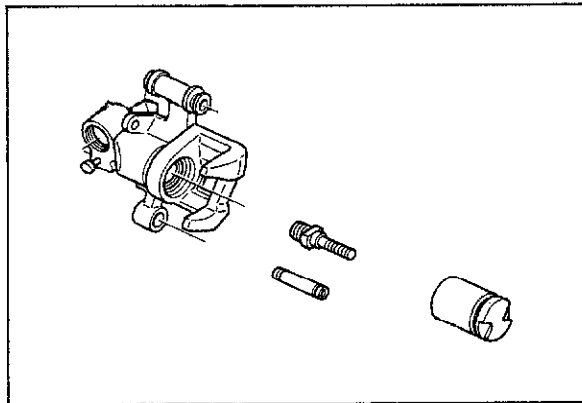

83U11X-102

## Inspection of Caliper Assembly

Check the following and repair or replace any faulty parts.

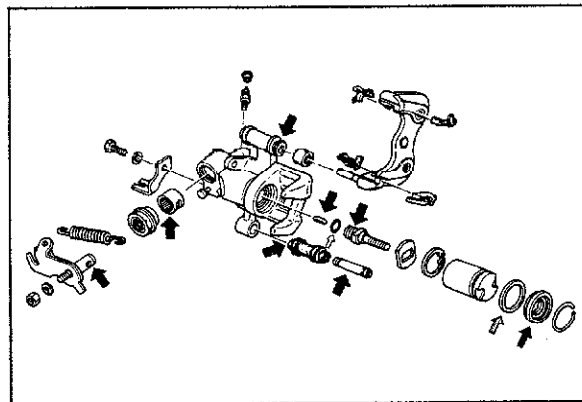

1. Cylinder and piston for wear and rust
2. Caliper body for damage and cracks
3. Mounting support for damage and cracks
4. Sleeve bolt and sleeve for damage and wear
5. Guide pin for damage and rust
6. Adjuster spindle threads for damage



83U11X-103

## Application of Grease

Before assembly, apply the grease supplied in the seal kit to the parts indicated by the arrows.

-  : Orange grease
-  : White grease
-  : Red grease

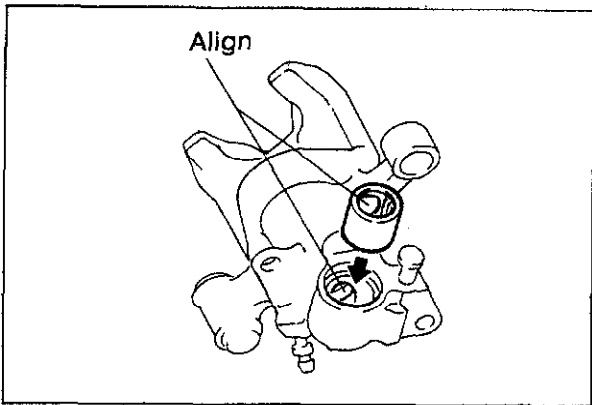

83U11X-104

### Needle Bearing

1. Align the needle bearing hole with the caliper hole, and set the needle bearing in the caliper.

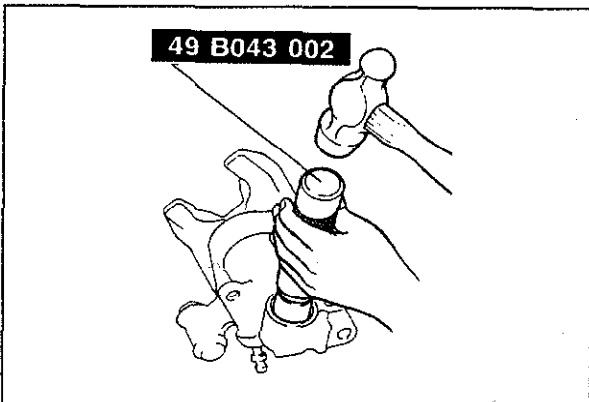

86U11X-098

2. Press the needle bearing into the caliper with the **SST** until the **SST** bottoms against the caliper.

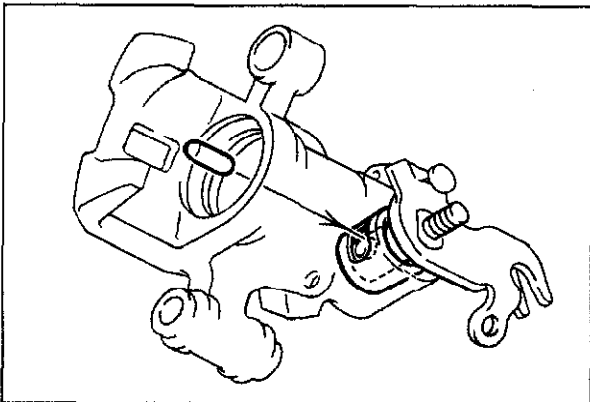

83U11X-105

### Connecting Link

Install the connecting link into the operating lever.

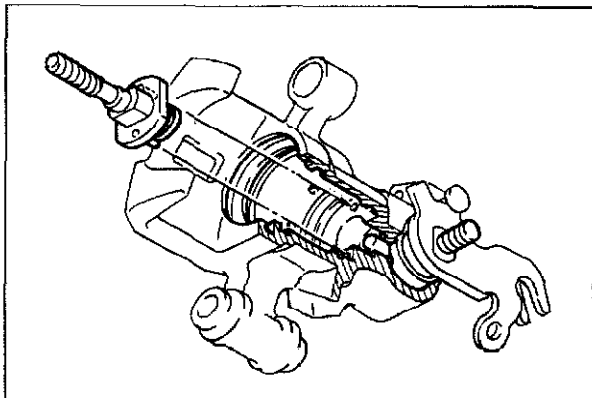

83U11X-106

### Adjuster Spindle

1. Assemble the adjuster spindle and the stopper.
2. Install the adjuster and stopper straight into the caliper cylinder with the two stopper pins fit into the caliper.
3. Install the snap ring.

# 11 REAR DISC BRAKE

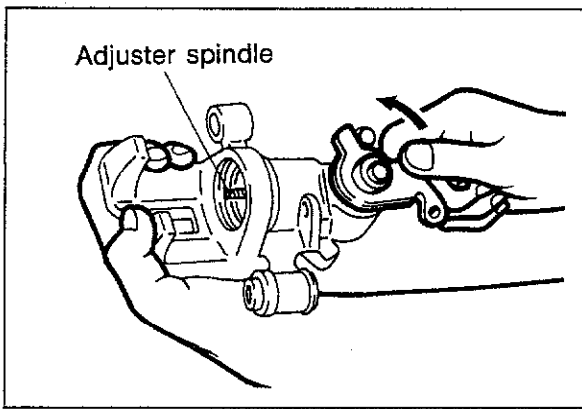

86U11X-101

4. Move the operating lever and check that the adjuster spindle moves smoothly.

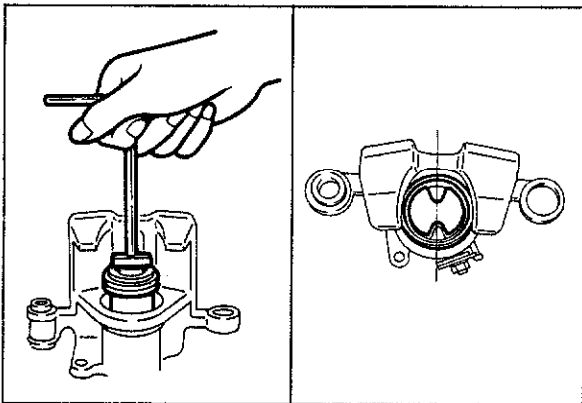

### Piston

1. Clean the piston.
2. Install the dust seal in the piston groove.
3. Turn the piston into the caliper cylinder while rotating the **SST** clockwise.

### Note

**Turn the piston in fully, and align the piston grooves as shown in the illustration.**

4. Fit the dust seal into the caliper cylinder.



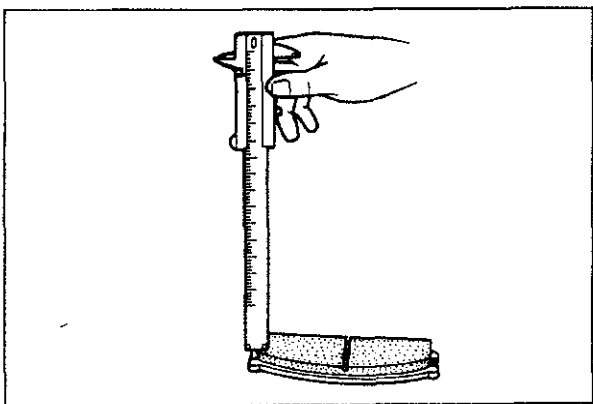

86U11X-103

## INSPECTION

Check the following and replace or repair any faulty parts.

### Disc Pad

1. Oil or grease on facing
2. Abnormal wear or cracks
3. Deterioration or heat damage
4. Remaining lining thickness

**Thickness: 1 mm (0.04 in) min.**

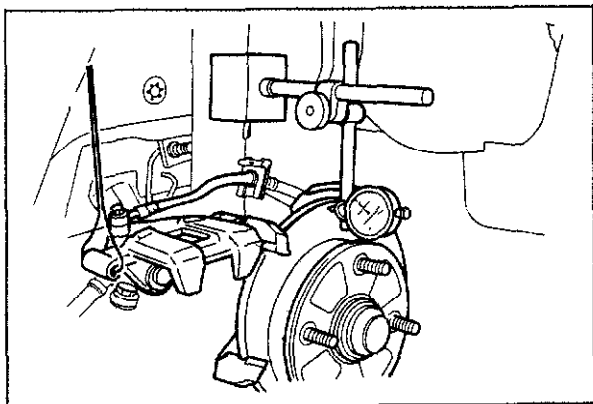

86U11X-104

### Disc Plate

1. Runout

**Runout: 0.1 mm (0.004 in) max.**

### Caution

- a) There must be no wheel bearing looseness.
- b) Measure at the outer edge of the disc plate surface.

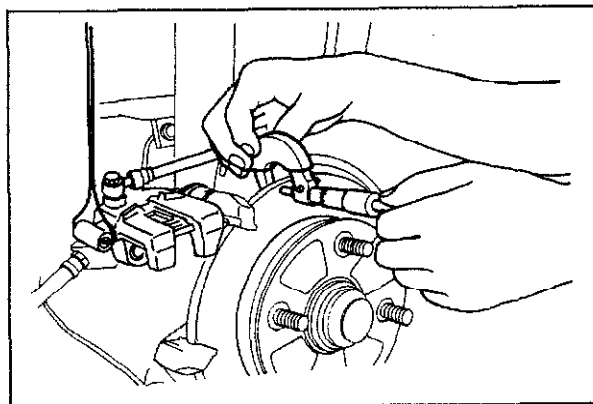

86U11X-105

2. Wear or damage

### Thickness

**Standard: 10 mm (0.39 in)**  
**Minimum: 8 mm (0.31 in)**

# 11 REAR DISC BRAKE

## INSTALLATION

1. Install in the reverse order of removal.
2. After installation:
  - (1) Add brake fluid and bleed air (Refer to page 11—11.)
  - (2) Adjust the parking brake lever stroke. (Refer to page 11—8.)
  - (3) Depress the brake pedal a few times and check that the rear brakes do not drag excessively while rotating the wheel.

### Note

Refer to page 11—38 for pad installation.

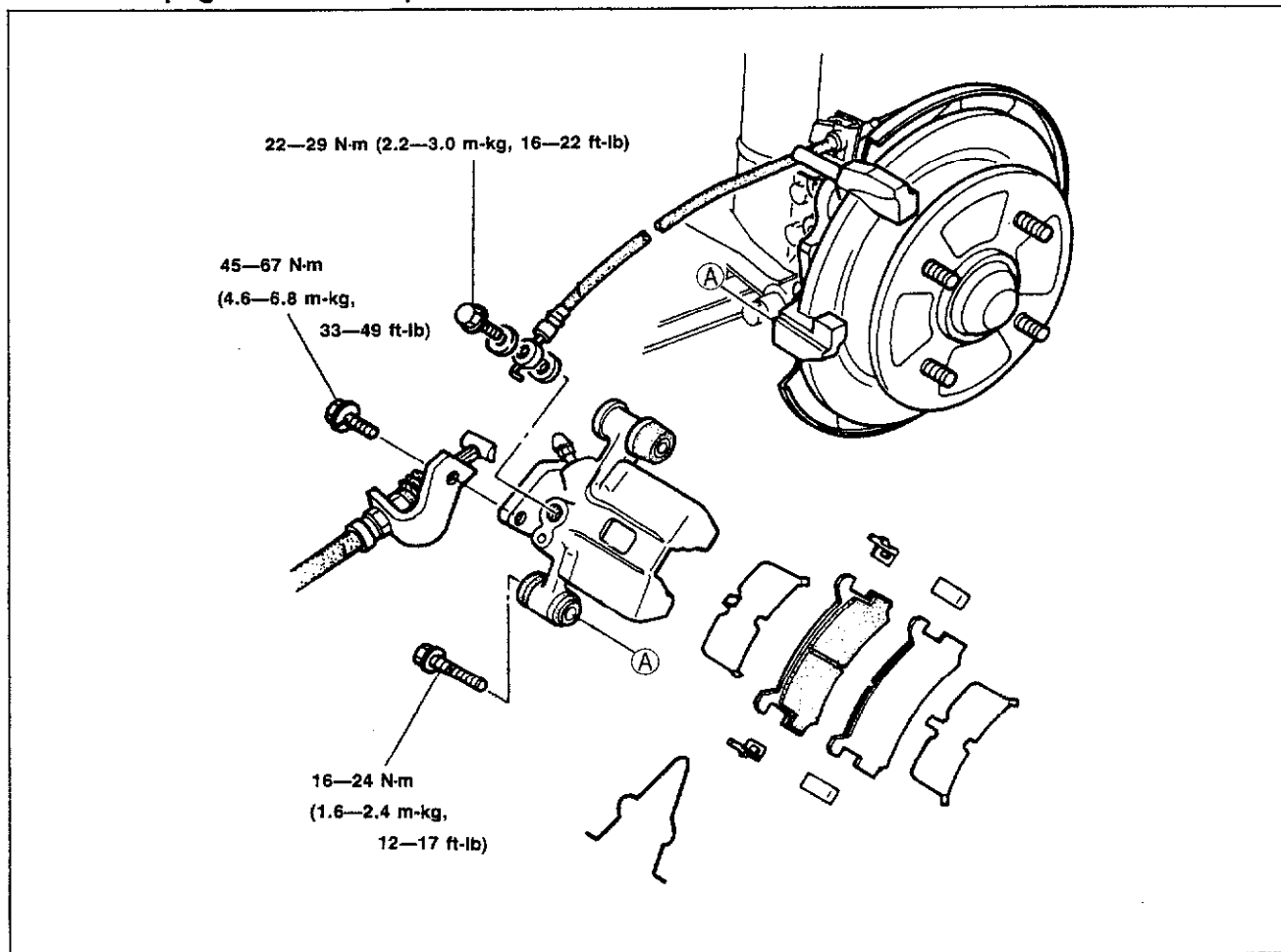

83U11X-084

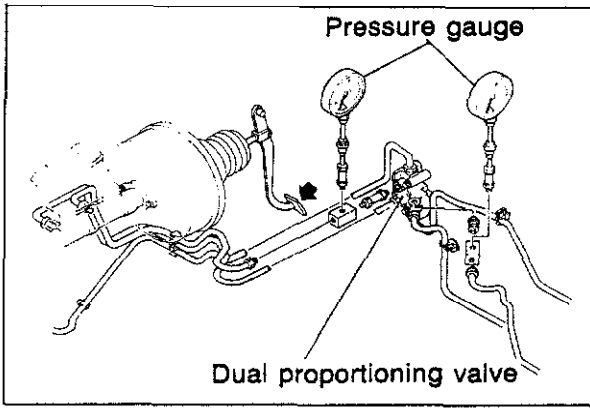

86U11X-060

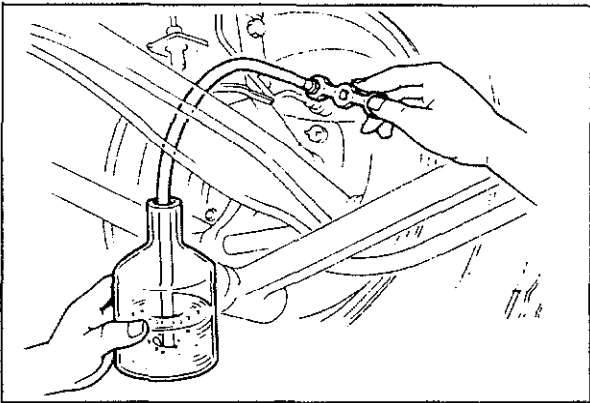

83U11X-085

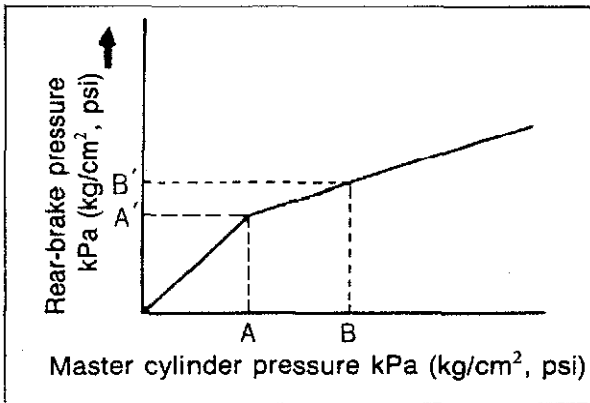

83U11X-021

## DUAL PROPORTIONING VALVE

### FUNCTION CHECK

1. Connect two pressure gauges [9,810 kPa (100 kg/cm<sup>2</sup>, 1,422 psi) ] to the brake pipes and adaptors as shown in the figure.

**Adaptor and flare nut tightening torque:**  
13—22 N·m (1.3—2.2 m·kg, 9—16 ft·lb)

### Note

**Disconnect and connect the brake pipes with the SST.**

2. Bleed air from the brake system. (Refer to page 11—11.)

3. Depress the brake pedal until the master cylinder pressure equals A; then measure rear brake pressure A'.
4. Depress the brake pedal again, apply additional pressure until A equals B; then measure pressure B'.

### Specification

	Fluid pressure kPa (kg/cm <sup>2</sup> , psi)			
	A	A'	B	B'
1600 cc (EGI)	2,943 (30, 427)	2,943 ± 196 (30 ± 2, 427 ± 28)	5,886 (60, 853)	3,826 ± 294 (39 ± 3, 555 ± 43)
1600 cc (DOHC, 2WD)	3,434 (35, 498)	3,434 ± 294 (35 ± 3, 498 ± 43)	5,886 (60, 853)	4,415 ± 392 (45 ± 4, 640 ± 57)
1600 cc (DHOC, 4WD)	2,943 (30, 427)	2,943 ± 196 (30 ± 2, 427 ± 28)	5,886 (60, 853)	4,120 ± 392 (42 ± 4, 597 ± 57)

5. If the measurements are not within specification, replace the valve assembly.
6. Install the brake pipes to the valve, and bleed air from the brake system.

# 11 DUAL PROPORTIONING VALVE

## REMOVAL AND INSTALLATION

1. Remove in the sequence shown in the figure.
2. Install in the reverse order of removal.
3. After installation:
  - (1) Add brake fluid and bleed the air (Refer to page 11—11.)
  - (2) Check the brake lines for fluid leakage.

### Caution

Brake fluid will damage painted surfaces. If it does get on a painted surface, wipe it off immediately.

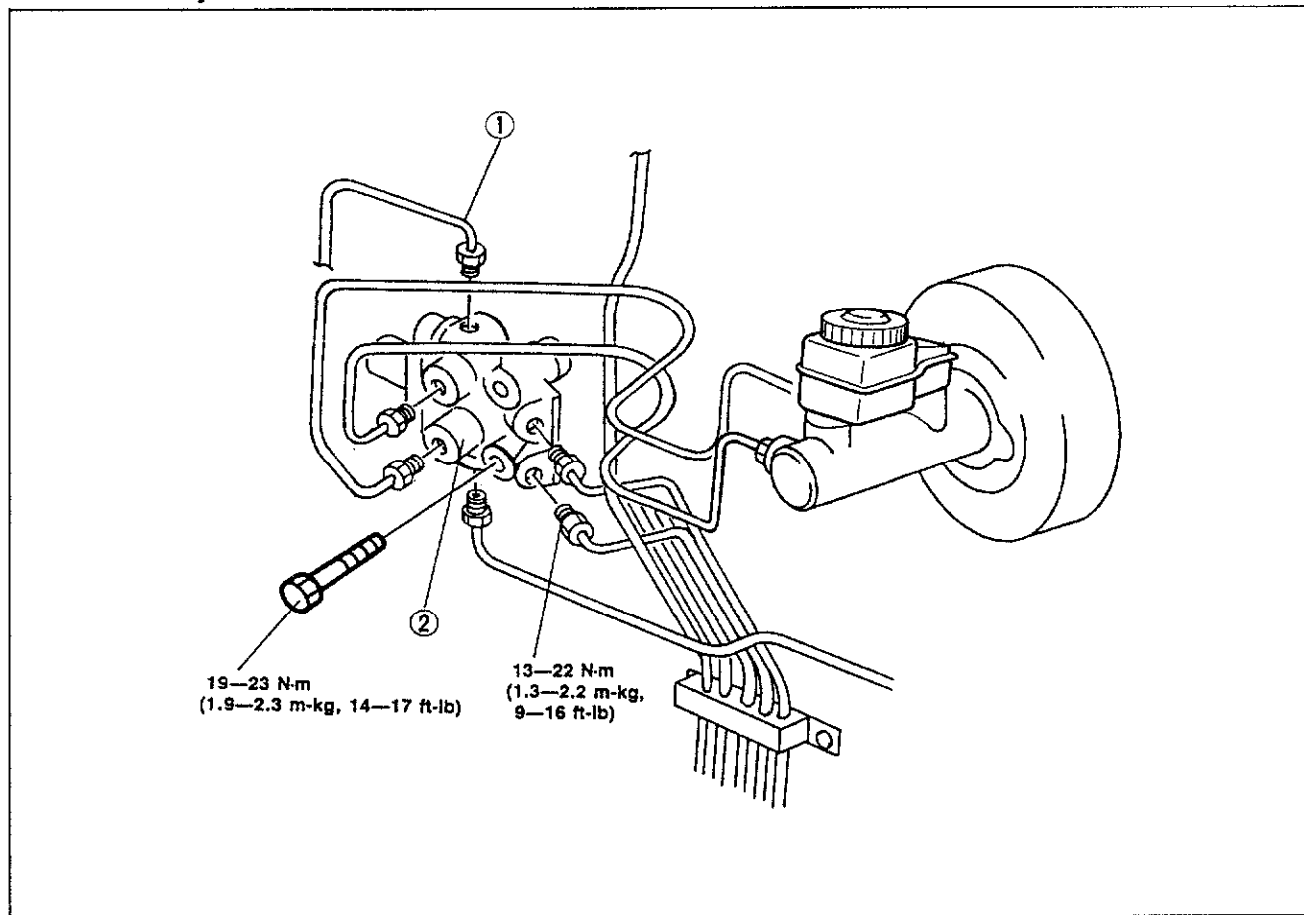

83U11X-086

1. Brake pipe

2. Dual proportioning valve

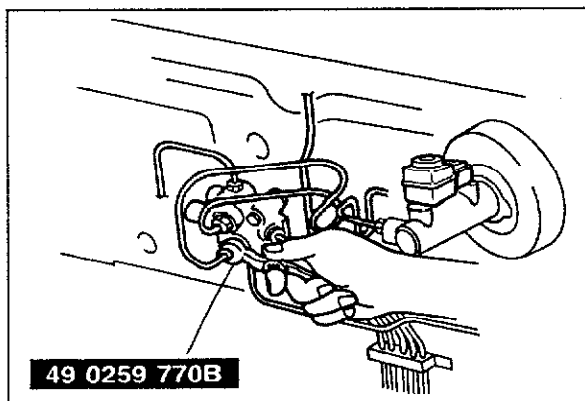

83U11X-111

### Brake Pipe

Disconnect or connect the brake pipes with the **SST**.

## PARKING BRAKE LEVER

### REMOVAL AND INSTALLATION

1. Block the wheels firmly.
2. Remove in the numbered sequence shown in the figure.
3. Install in the reverse order of removal.
4. After installation, adjust the stroke. (See page 11—8).

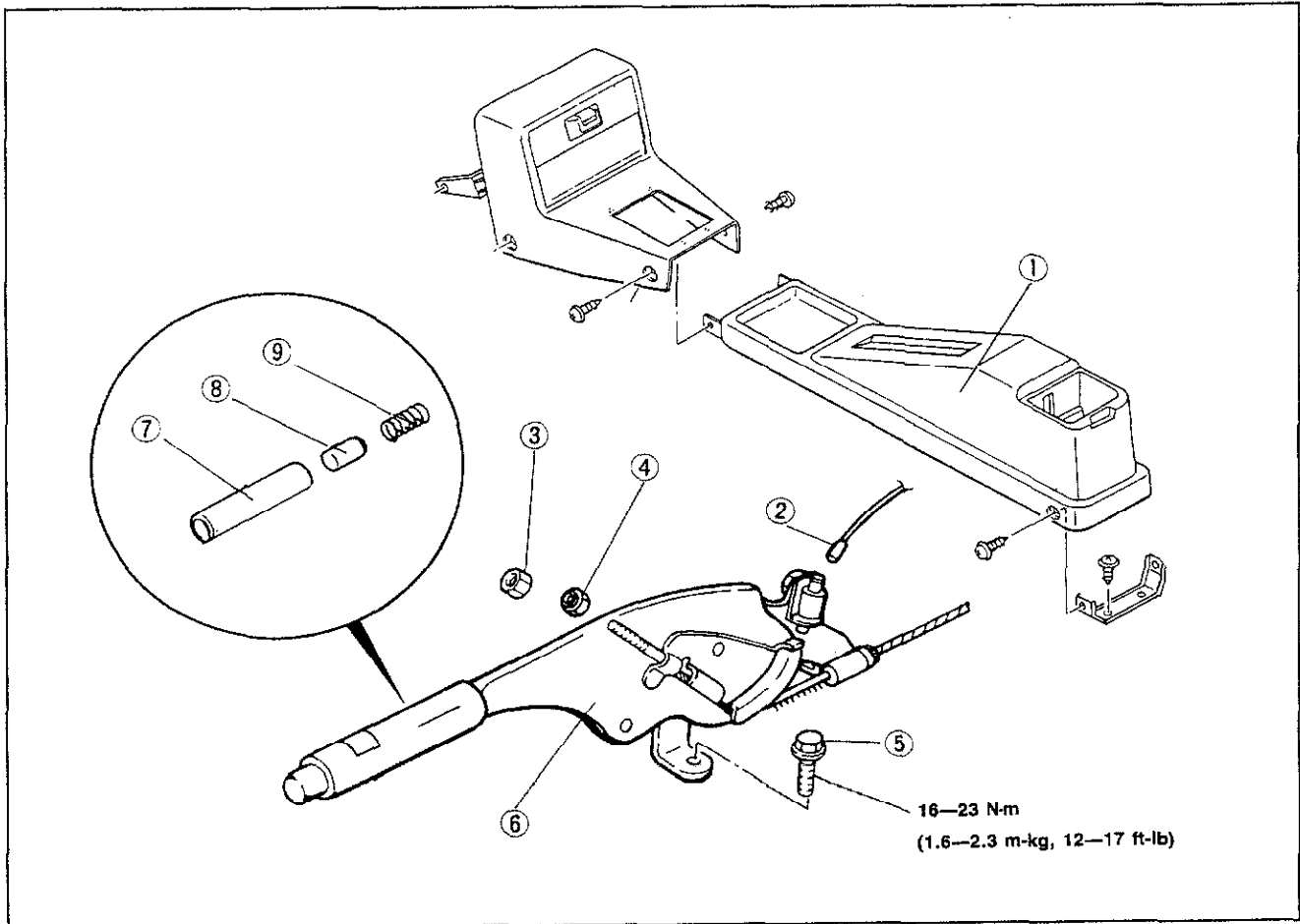

83U11X-087

- |                 |                        |                   |
|-----------------|------------------------|-------------------|
| 1. Rear console | 4. Adjust nut          | 7. Grip           |
| 2. Coupler      | 5. Bolt                | 8. Release button |
| 3. Locknut      | 6. Parking brake lever | 9. Return spring  |

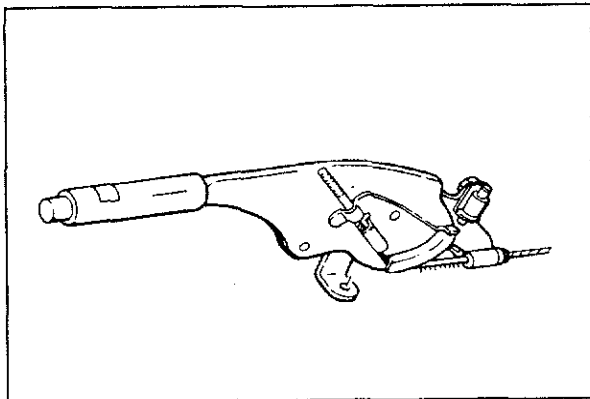

63U11X-085

### INSPECTION

1. Sector and ratchet pawl for wear or damage
2. Spring for weakness or breakage

# 11 PARKING BRAKE CABLE

## PARKING BRAKE CABLE

### REMOVAL AND INSTALLATION

1. Jack up the vehicle and support it with safety stands.
2. Remove in the numbered sequence shown in the figure.
3. Install in the reverse order of removal.

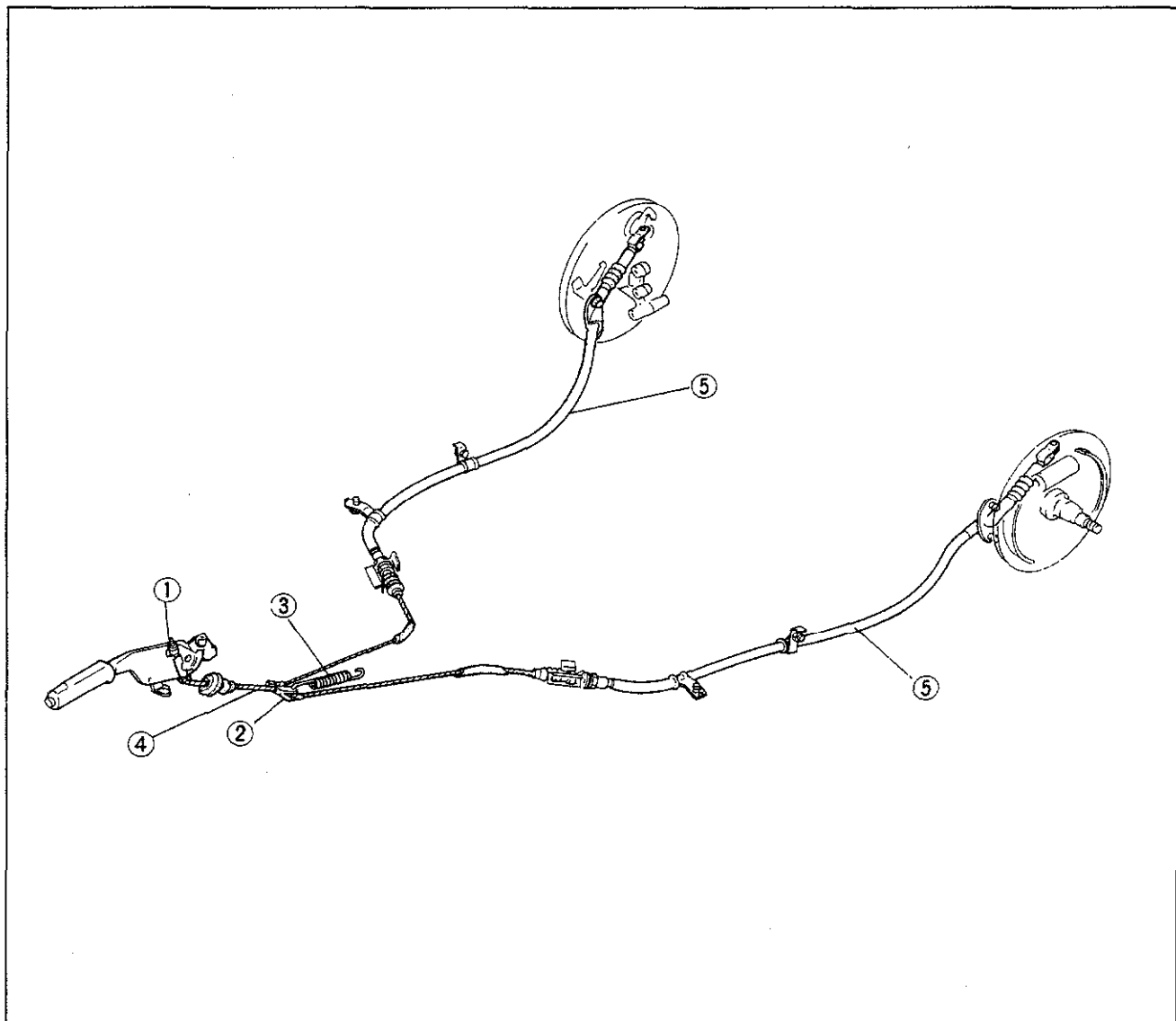

63U11X-086

1. Adjusting nut  
2. Equalizer

3. Return spring  
4. Front parking brake cable

5. Rear parking brake cable

# WHEELS AND TIRES

<b>OUTLINE</b> .....	<b>12— 2</b>
SPECIFICATIONS .....	12— 2
<b>TROUBLESHOOTING GUIDE</b> .....	<b>12— 2</b>
<b>WHEELS AND TIRES</b> .....	<b>12— 3</b>
INSPECTION AND ADJUSTMENTS .....	12— 3
TIRE ROTATION .....	12— 4
WHEEL BALANCE .....	12— 5
WHEEL MOUNTING .....	12— 5
SPECIAL NOTE .....	12— 5

86U12X-001

# 12 OUTLINE, TROUBLESHOOTING GUIDE

## OUTLINE

### SPECIFICATIONS

Item		Type	Standard	Temporary spare	
Wheels	Size		4 1/2-J x 13, 5-J x 13 5 1/2-JJ x 14	4-T x 14	
	Offset mm (in)		45 (1.77)	50 (1.97)	
	Diameter of pitch circle mm (in)		114.3 (4.5)		
	Material		Steel or aluminum alloy	Steel	
Tires	Size	4 1/2-J x 13	155SR13, P155/80R13	T105/70D14	
		5-J x 13	175/70SR13, P175/70R13		
		5 1/2-JJ x 14	185/60R14 82H		
	Air pressure kPa (kgf/cm <sup>2</sup> , psi)	Front		196 (2.0, 28)	412 (4.2, 60)
		Rear		177 (1.8, 26)	

83U12X-001

## TROUBLESHOOTING GUIDE

Problem	Possible Cause	Remedy	Page
<b>Excessive or irregular tire wear</b>	Refer to page 12— 3 for details.		
<b>Premature tire wear</b>	Incorrect tire pressure	Adjust	12— 2
<b>Tire squeal</b>	Incorrect tire pressure Tire deterioration	Adjust Replace	12— 2 —
<b>Road noise or body vibration</b>	Insufficient tire pressure	Adjust	12— 2
	Unbalanced wheel(s)	Adjust	12— 5
	Deformed wheel(s) or tire(s)	Repair or replace	—
	Irregular tire wear	Replace	—
<b>Steering wheel vibration</b>	Irregular tire wear	Replace	—
	Right and left tread depths different	Replace	—
	Deformed or unbalanced wheel(s)	Replace or adjust	12— 5
	Deformed tire(s)	Replace	—
	Unequal tire pressures	Adjust	12— 2
	Loose lug nuts	Tighten	12— 5
<b>Uneven (one-sided) braking</b>	Unequal tire pressures	Adjust	12— 2
<b>Steering wheel doesn't return properly, or pulls to either left or right while vehicle moving on level road surface</b>	Incorrect tire pressure	Adjust	12— 2
	Irregular tire wear (left and right are different)	Replace	—
	Unequal tire pressures	Adjust	12— 2
	Different types or brands of tires mixed (right/left)	Replace	—
	Improperly tightened lug nuts	Tighten	12— 5
<b>General driving instability</b>	Unequal tire pressures	Adjust	12— 2
	Deformed or unbalanced wheel(s)	Replace or adjust	12— 5
	Loose lug nuts	Tighten	12— 5
<b>Excessive steering wheel play</b>	Loose lug nuts	Tighten	12— 5

86U12X-003



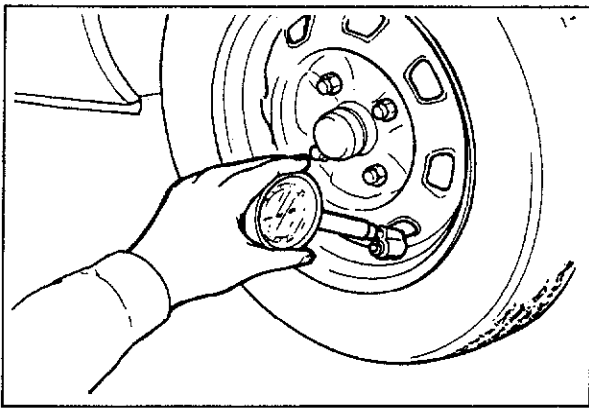

86U12X-004

## WHEELS AND TIRES

### INSPECTION AND ADJUSTMENTS

Check the following, and adjust or replace as necessary.

#### 1. Air pressure

Check the air pressure of all tires, including the spare tire, with an air pressure gauge.

(Refer to page 12—2.)

#### Caution

**The air pressure must be measured when the tire is cold.**

#### 2. Tire wear

### Specifications

#### Remaining tread

**Ordinary tires: 1.6 mm (0.063 in) min.**

(Tire should be replaced if wear indicators are exposed.)

**Snow tires: 50% of tread**

(Tire should be replaced if wear indicators are exposed.)

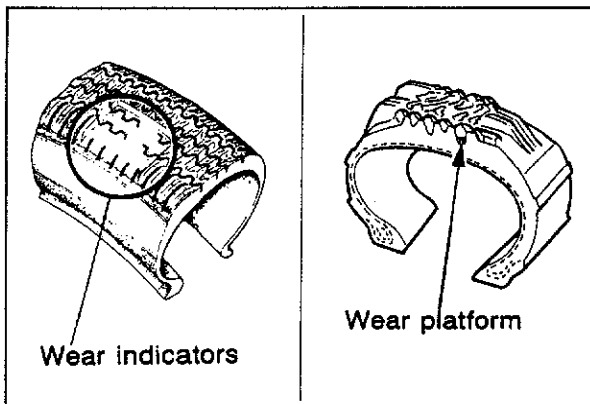

86U12X-005

### Troubleshooting guide

Abnormal tire wear patterns shown in the illustration can occur. Refer to the chart for the probable causes and remedies.

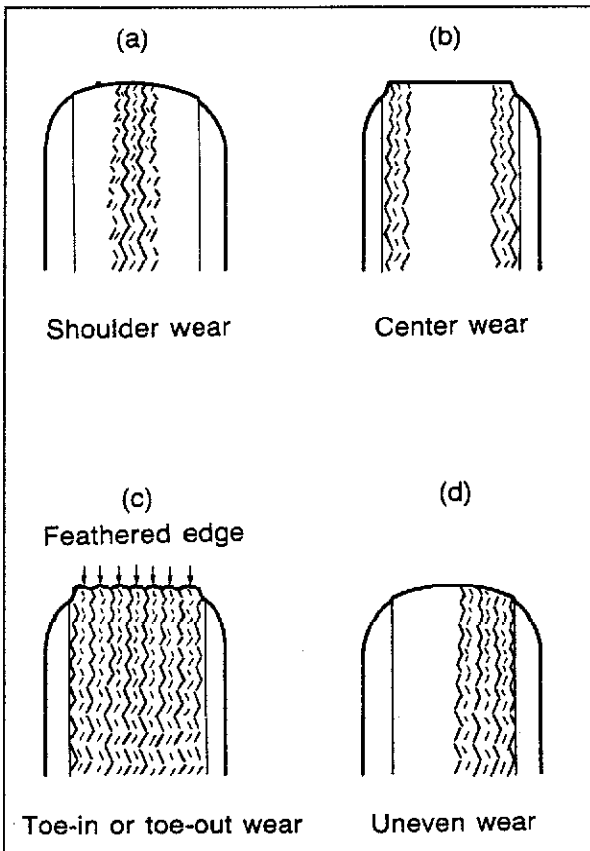

86U12X-006

	Probable cause	Remedy
(a)	<ul style="list-style-type: none"> <li>Underinflation (both sides worn)</li> <li>Incorrect camber (one side wear)</li> <li>Hard cornering</li> <li>Lack of rotation</li> </ul>	<ul style="list-style-type: none"> <li>Measure and adjust pressure</li> <li>Repair, or replace axle and suspension parts</li> <li>Reduce speed</li> <li>Rotate tires</li> </ul>
(b)	<ul style="list-style-type: none"> <li>Overinflation</li> <li>Lack of rotation</li> </ul>	<ul style="list-style-type: none"> <li>Measure and adjust pressure</li> <li>Rotate tires</li> </ul>
(c)	<ul style="list-style-type: none"> <li>Incorrect toe-in</li> </ul>	<ul style="list-style-type: none"> <li>Adjust toe-in</li> </ul>
(d)	<ul style="list-style-type: none"> <li>Incorrect camber or caster</li> <li>Malfunctioning suspension</li> <li>Unbalanced wheel</li> <li>Out-of-round brake drum or disc</li> <li>Other mechanical conditions</li> <li>Lack of rotation</li> </ul>	<ul style="list-style-type: none"> <li>Repair, or replace axle and suspension parts</li> <li>Repair or replace</li> <li>Balance or replace</li> <li>Correct or replace</li> <li>Correct or replace</li> <li>Rotate tires</li> </ul>

# 12 WHEELS AND TIRES

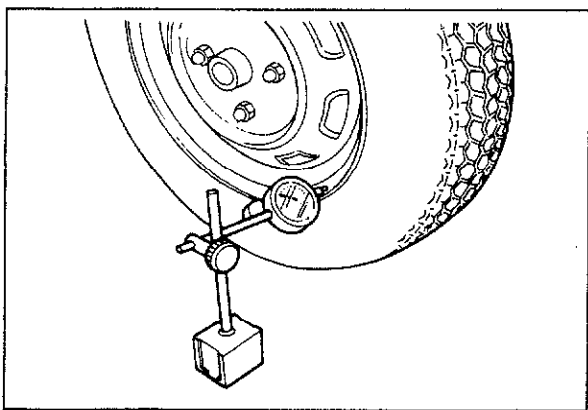

83U12X-002

### 3. Wheel deflection

Set the probe of a dial indicator against the wheel, and turn the wheel one full revolution.

#### Wheel deflection limit

mm (in)

	Horizontal	Vertical
Steel wheel	2.5 (0.098)	1.5 (0.059)
Aluminum wheel	2.0 (0.079)	

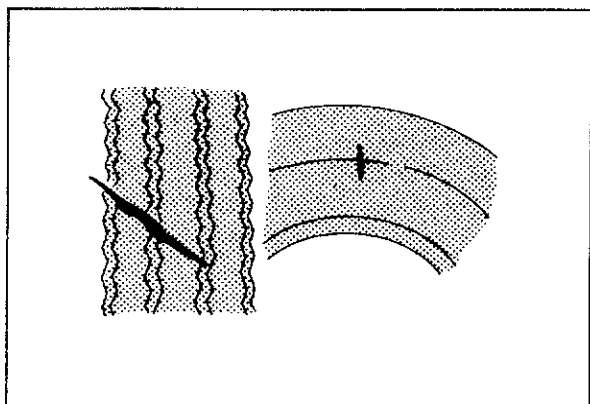

86U12X-008

4. Cracks, damage, or foreign matter (such as metal pieces, nails, and stones) in the tire and cracks, deformation, and damage to the wheel

5. Loose wheel lug nut(s)

6. Air leaking from the valve stem

### TIRE ROTATION

To prolong tire life and assure uniform wear, rotate the tires every 6,000 km (3,750 miles) or sooner if irregular wear develops.

#### Caution

a) Do not include "TEMPORARY USE ONLY" spare tire in rotation.

b) After rotating the tires, adjust each tire to the specified air pressure (Refer to page 12—2.)

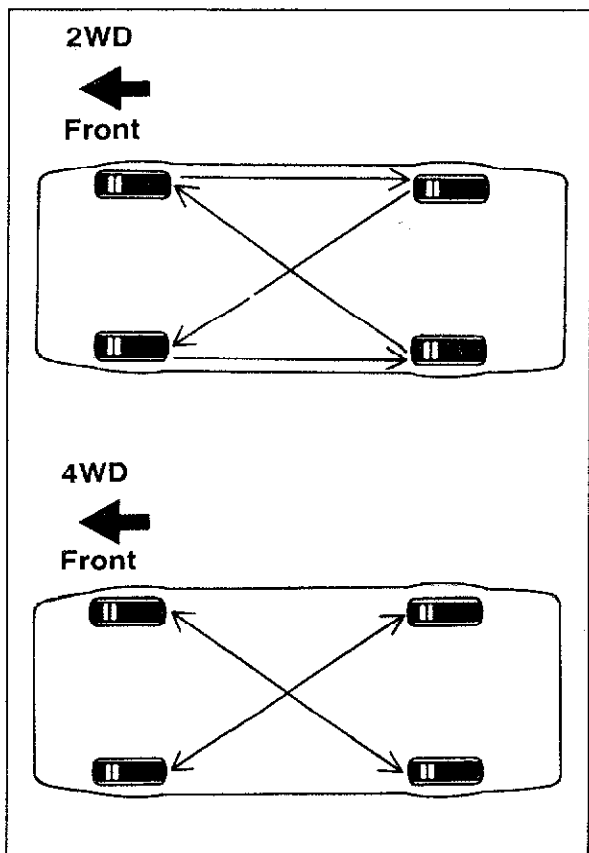

83U12X-003

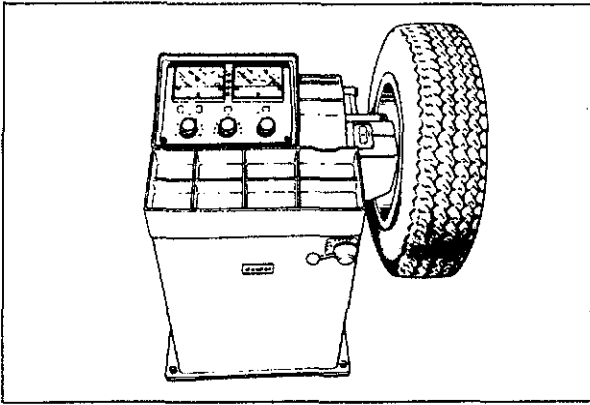

83U12X-004

## WHEEL BALANCE

If a wheel becomes unbalanced or if a tire is replaced or repaired, the wheel must once again be balanced to within specification.

### Maximum unbalance (at rim edge):

13 inch-wheel	11g (0.39 oz)
14 inch-wheel	10g (0.35 oz)

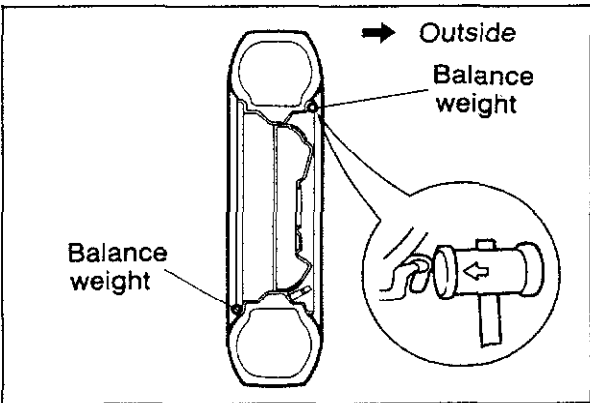

86U12X-011

### Caution

- a) Do not use more than two balance weights on the inner or outer side of the wheel. If the total weight exceeds 100 g (3.5 oz), re-balance after moving the tire around on the rim.
- b) Attach the balance weights tightly so that they do not protrude more than 3 mm (0.12 in) beyond the wheel edge.
- c) Select suitable balance weights for steel or aluminum alloy wheels.
- d) Do not use an on-car balancer on ATX models. Use of this type of balancer may cause clutch damage.

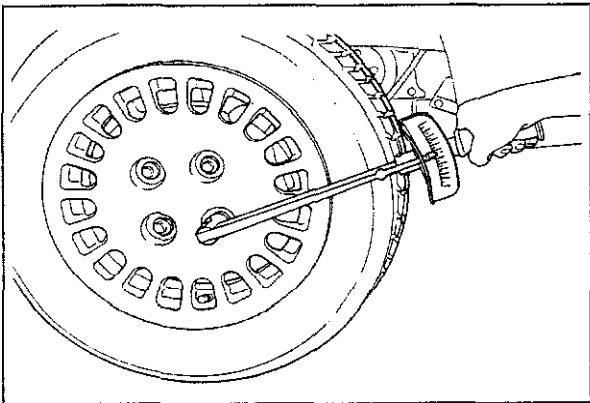

86U12X-012

## WHEEL MOUNTING

Tighten the lug nuts to the specified torque in a criss-cross fashion.

### Tightening torque:

88—118 N·m (9—12 m·kg, 65—87 ft·lb)

### Caution

- a) The wheel-to-hub contact surfaces must be clean.
- b) Never apply oil to the nuts, bolts, or wheels; doing so might cause looseness or seizure of the lug nuts.

## SPECIAL NOTE

### Regarding wheels and tires:

1. Do not use wheels or tires other than the specified types.
2. Aluminum wheels are easily scratched. When washing them, use a soft cloth, never a wire brush. If the vehicle is steam cleaned, do not allow boiling water to contact the wheels.
3. If alkaline compounds (such as salt water or road salts), get on aluminum wheels, wash them as soon as possible to prevent damage. Use only a neutral detergent.

86U12X-013

# 12 WHEELS AND TIRES

---

## Regarding tire replacement:

Note the following points when tires are to be removed from or mounted onto the wheels.

1. Be careful not to scratch the tire bead, the rim bead, or the edge of the rim.
2. Apply a soapy solution to the tire bead and the edge of the rim.
3. Use a wire brush, sandpaper, or a cloth to clean and remove all rust, dirt, etc., from the rim edge and the rim bead. For aluminum wheels, use only a cloth for this purpose; never use a wire brush or sandpaper.
4. Remove any pebbles, glass, nails, etc., embedded in the tire tread.
5. Be sure the air valve is installed correctly.
6. After mounting a tire onto a wheel, inflate the tire to 250—300 kPa (2.55—3.06 kg/cm<sup>2</sup>, 35.55—42.66 psi). Check to be sure that the bead is seated correctly onto the rim, and that there are no air leaks. Then reduce the pressure to the specified level.
7. If a tire iron is used to change a tire on an aluminum wheel, be sure to use a piece of rubber between the iron lever and the wheel in order to avoid damage to the wheel. Work should be done on a rubber mat, not on a hard or rough surface.

86U12X-014

# SUSPENSION

<b>OUTLINE</b> .....	13— 2
STRUCTURAL VIEW .....	13— 2
SPECIFICATIONS.....	13— 3
<b>TROUBLESHOOTING GUIDE</b> .....	13— 4
<b>FRONT SHOCK ABSORBER AND SPRING</b>	13— 6
REMOVAL AND INSTALLATION .....	13— 6
DISASSEMBLY AND ASSEMBLY .....	13— 7
INSPECTION .....	13— 9
<b>FRONT LOWER ARM</b> .....	13—10
REMOVAL AND INSTALLATION .....	13—10
INSPECTION .....	13—12
<b>FRONT STABILIZER</b> .....	13—13
REMOVAL AND INSTALLATION .....	13—13
INSPECTION .....	13—14
<b>REAR SHOCK ABSORBER AND SPRING</b> ..	13—15
REMOVAL AND INSTALLATION .....	13—15
DISASSEMBLY AND ASSEMBLY .....	13—16
INSPECTION .....	13—18
<b>LATERAL LINK AND TRAILING LINK</b> .....	13—19
REMOVAL AND INSTALLATION .....	13—19
<b>REAR STABILIZER</b> .....	13—20
REMOVAL AND INSTALLATION .....	13—20
INSPECTION .....	13—21
<b>REAR WHEEL ALIGNMENT</b> .....	13—22
PRE-INSPECTION .....	13—22
TOE-IN .....	13—22
CAMBER .....	13—24

## OUTLINE

### STRUCTURAL VIEW

2WD

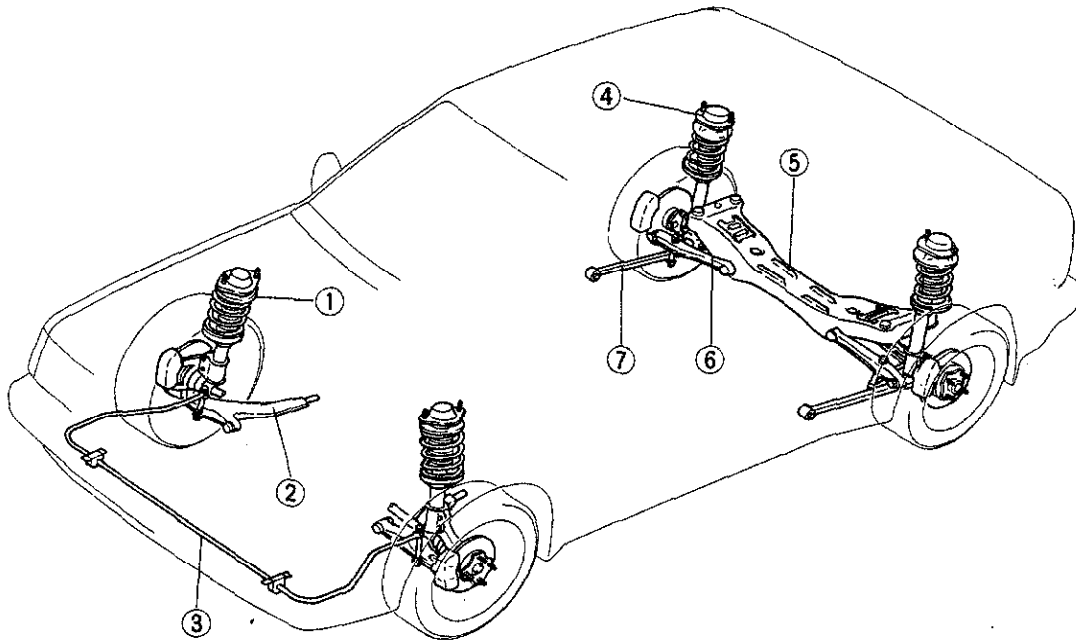

4WD

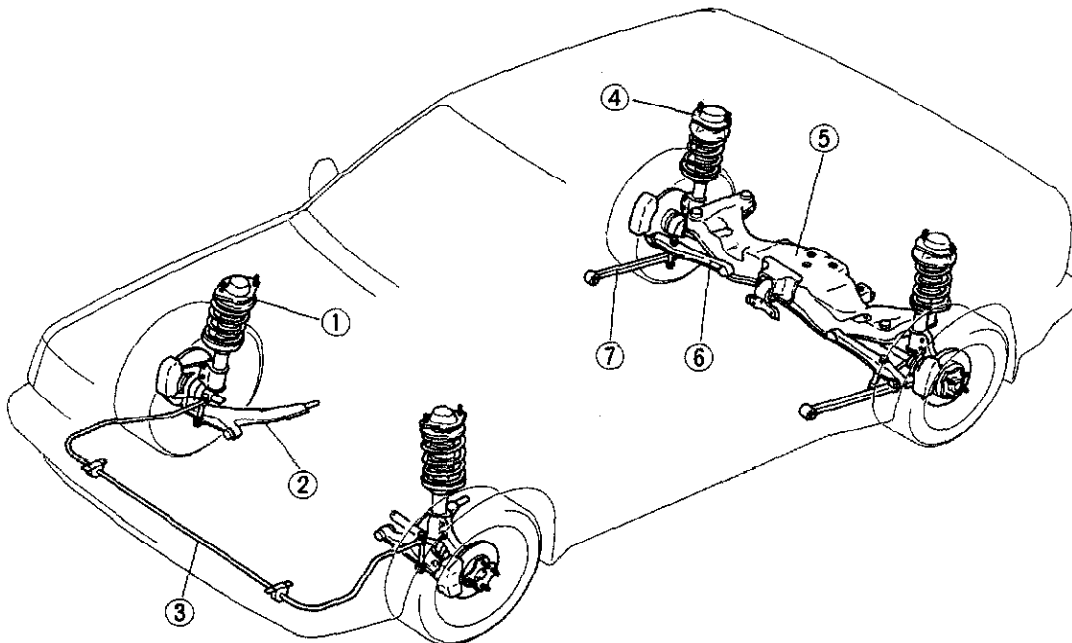

83U13X-002

- 1. Front shock absorber
- 2. Lower arm
- 3. Front stabilizer
- 4. Rear shock absorber

- 5. Crossmember
- 6. Lateral link
- 7. Trailing link

**SPECIFICATIONS  
2WD (B6 EGI)**

Item		Model	MTX	ATX
<b>Front suspension</b>				
Suspension			Strut type	
Spring			Coil spring	
Spring dimensions	Wire diameter	mm (in)	12.5 (0.49)	12.8 (0.50)
	Coil diameter	mm (in)	132.5—134.7 (5.22—5.30)	134.3—136.4 (5.29—5.37)
	Free length	mm (in)	391 (15.4)	372 (14.6)
	Coil number (active)		4.96	5.60
Shock absorber			Cylindrical double-acting	
Stabilizer	Type		Torsion bar	
	Diameter	mm (in)	27.2 (1.07)	

Item		Model	Hatchback	Sedan
<b>Rear suspension</b>				
Suspension			Strut type	
Spring			Coil spring	
Spring dimensions	Wire diameter	mm (in)	10.2 (0.40)	10.5 (0.41)
	Coil diameter	mm (in)	112.5 (4.43)	113.2 (4.46)
	Free length	mm (in)	351 (13.8)	376 (14.8)
	Coil number (active)		4.62	5.62
Shock absorber			Cylindrical double-acting	
Stabilizer	Type		Torsion bar	
	Diameter	mm (in)	15.9 (0.63)	

83U13X-003

**2WD (B6 DOHC)**

Item		Model	Hard	ASA
<b>Front suspension</b>				
Suspension			Strut type	
Spring			Coil spring	
Spring dimensions	Wire diameter	mm (in)	12.8 (0.50)	12.5 (0.49)
	Coil diameter	mm (in)	134.3—136.4 (5.29—5.37)	133.0—135.5 (5.24—5.33)
	Free length	mm (in)	372 (14.6)	393 (15.5)
	Coil number (active)		5.60	4.07
Shock absorber			Cylindrical double-acting	
Stabilizer	Type		Torsion bar	
	Diameter	mm (in)	29.2 (1.15)	
<b>Rear suspension</b>				
Suspension			Strut type	
Spring			Coil spring	
Spring dimensions	Wire diameter	mm (in)	10.2 (0.40)	10.0 (0.39)
	Coil diameter	mm (in)	113.2 (4.46)	113.0 (4.45)
	Free length	mm (in)	351 (13.8)	394.6 (15.54)
	Coil number (active)		4.62	4.62
Shock absorber			Cylindrical double-acting	
Stabilizer	Type		Torsion bar	
	Diameter	mm (in)	Hatchback: 15.9 (0.63) Sedan: 17.3 (0.68)	17.3 (0.68)

ASA: Adjustable Shock Absorber

83U13X-004

# 13 OUTLINE, TROUBLESHOOTING GUIDE

## 4WD (B6 DOHC)

Item		Model	Hard
<b>Front suspension</b>			
Suspension			Strut type
Spring			Coil spring
Spring dimensions	Wire diameter	mm (in)	11.25 (0.44)
	Coil diameter	mm (in)	135 (5.31)
	Free length	mm (in)	436 (17.16)
	Coil number (active)		5.2
Shock absorber			Cylindrical double-acting
Stabilizer	Type		Torsion bar
	Diameter	mm (in)	29.2 (1.15)
<b>Rear suspension</b>			
Suspension			Strut type
Spring			Coil spring
Spring dimensions	Wire diameter	mm (in)	10.5 (0.41)
	Coil diameter	mm (in)	128 (5.04)
	Free length	mm (in)	356.8 (14.05)
	Coil number (active)		3.65
Shock absorber			Cylindrical double-acting
Stabilizer	Type		Torsion bar
	Diameter	mm (in)	15.9 (0.63)

83U13X-005

## TROUBLESHOOTING GUIDE

Problem	Possible Cause	Remedy	Page
<b>Body "rolls"</b>	Weak stabilizer	Replace	13—13, 20
	Worn or deteriorated stabilizer or lower arm bushing	Replace	13—10,13,20
	Malfunction of shock absorbers	Replace	13—6, 15
<b>Poor riding comfort</b>	Weak coil springs	Replace	13—7, 16
	Malfunction of shock absorbers	Replace	13—6, 15
<b>Body tilt</b>	Worn coil springs	Replace	13—7, 16
	Worn stabilizer or lower arm bushing	13—10,13,20	
<b>Abnormal noise from suspension system</b>	Poor lubrication or wear of lower arm ball joint	Replace	13—10
	Looseness of peripheral connections	Tighten	—
	Malfunction of shock absorbers	Replace	13—6, 15
	Worn or deteriorated stabilizer or lower arm bushing	Replace	13—10,13,20
	Wear or damage of front strut bearing	Replace	13—7
<b>"Heavy" steering wheel operation</b>	Lower arm ball joint stuck	Replace	13—10
	Ball joints stuck or damaged	Replace	—
	Ball joints insufficiently lubricated; foreign material; abnormal wear	Lubricate or replace	—
	Improperly adjusted wheel alignment (toe-in)	Adjust	—
	Worn or damaged steering gear bushing	Replace	—
	Improperly adjusted pinion pre-load	Adjust	—
	Damaged steering gear	Replace	—
	Insufficient grease on steering gear	Add grease	—
	Malfunction of steering shaft universal joint	Repair or replace	—
	Low tire pressure	Adjust	—
Abnormal tire wear	Replace	—	
<b>Steering wheel pulls to one side</b>	Weak coil spring	Replace	13—7, 16
	Worn or damaged stabilizer or lower arm bushing	Replace	13—10,13,20
	Damaged knuckle arm	Replace	—
	Lower arm damaged or loose	Replace or tighten	13—10
	Improperly adjusted wheel alignment (toe-in)	Adjust	—
Damaged steering linkage	Replace	—	

83U13X-006



Problem	Possible Cause	Remedy	Page
<b>Steering wheel pulls to one side</b>	Damaged wheel bearing	Replace	—
	Uneven tire pressure	Adjust	—
	Abnormal tire wear (left and right worn differently)	Replace	—
	Brakes dragging	Repair	—
<b>Steering wheel vibrates</b>	Worn or deteriorated stabilizer or lower arm bushing	Replace	13—10, 13, 20
	Worn lower arm ball joint	Replace	13—10
	Malfunction or looseness of shock absorber	Replace or tighten	13—6, 15
	Improperly adjusted wheel alignment (toe-in)	Adjust	—
	Damaged linkage	Replace	—
	Worn or damaged joints	Replace	—
	Improperly adjusted pinion preload	Adjust	—
	Worn steering gear bushing	Replace	—
	Loose steering shaft universal joint	Replace	—
	Malfunction of wheel bearing	Replace	—
	Abnormal tire wear	Replace	—
	Tire tread depth different (left/right)	Replace	—
	Damaged or unbalanced wheel	Replace or repair	—
<b>Excessive steering wheel play</b>	Worn or damaged lower arm bushing	Replace	13—10
	Improperly adjusted pinion preload	Adjust	—
	Work rack and pinion	Replace	—
	Worn or damaged joints	Replace	—
	Loose steering shaft universal joint	Replace	—
<b>General instability</b>	Weakened coil springs	Replace	13—7, 16
	Malfunction of shock absorbers	Replace	13—6, 15
	Wear or deterioration of lower arm of stabilizer bushing	Replace	13—10, 13, 20
	Improperly adjusted wheel alignment	Adjust	—
	Damaged linkage	Replace	—
	Worn or damaged joints	Replace	—
	Improperly adjusted pinion preload	Adjust	—
	Loose steering shaft universal joint	Replace	—
	Incorrect tire pressure	Adjust	—
	Damaged or unbalanced wheel	Repair or replace	—
	Malfunction of wheel bearing	Replace	—

83U13X-007

## FRONT SHOCK ABSORBER AND SPRING

### REMOVAL AND INSTALLATION

1. Jack up the front of the vehicle and support it with safety stands.
2. Remove in the sequence shown in the figure.
3. Install in the reverse order of removal.

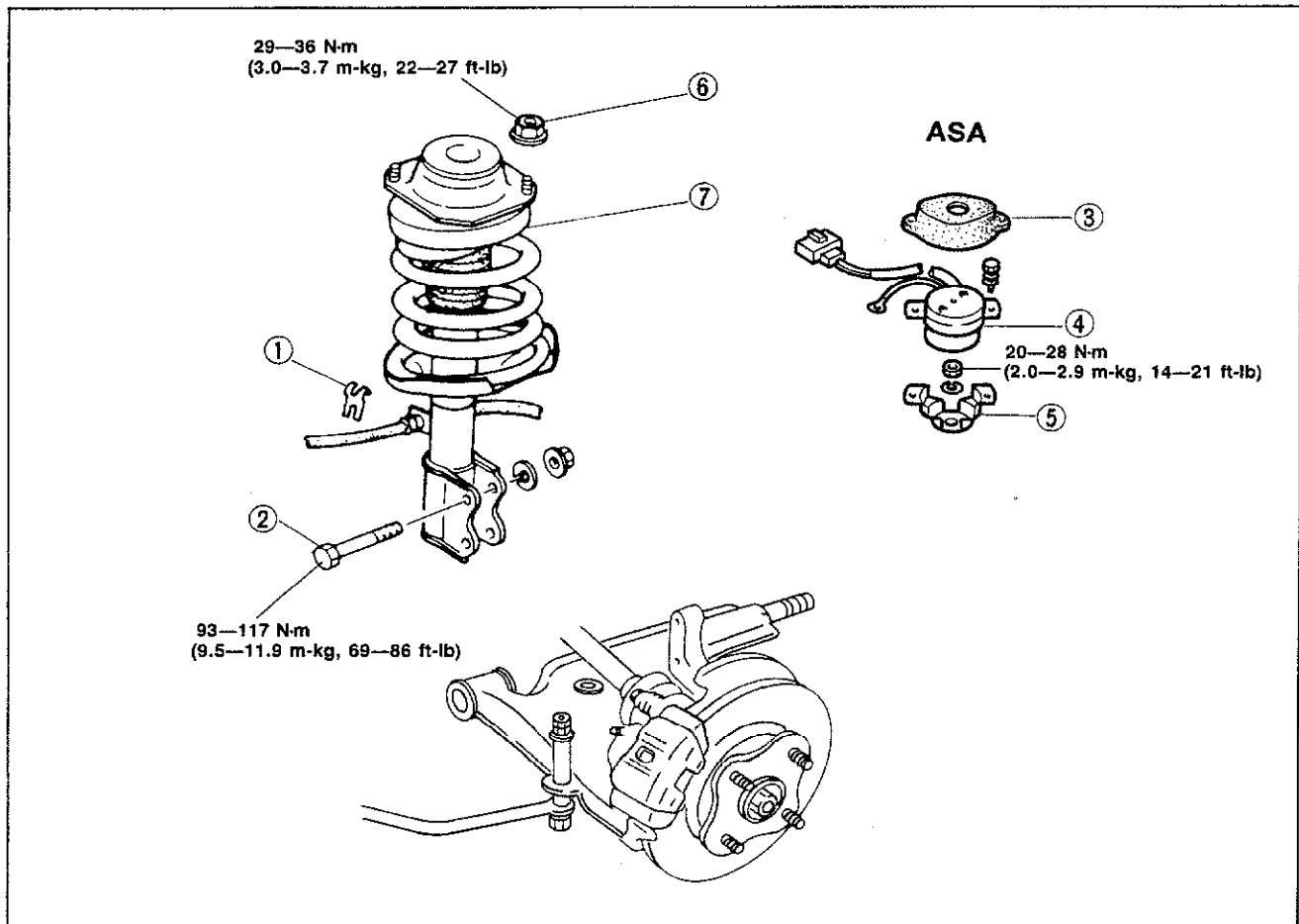

83U13X-008

1. Brake hose clip
2. Bolt
3. Rubber cap (ASA)

4. Actuator (ASA)
5. Bracket (ASA)
6. Nut

7. Shock absorber

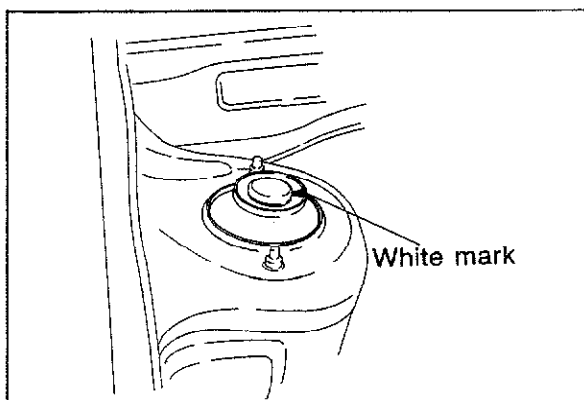

83U13X-009

### Shock Absorber

Install the shock absorber to the suspension tower so that the white mark on the mounting block faces the inside of the vehicle.

## DISASSEMBLY AND ASSEMBLY

1. Disassemble in the sequence shown in the figure.
2. Assemble in the reverse order of removal.

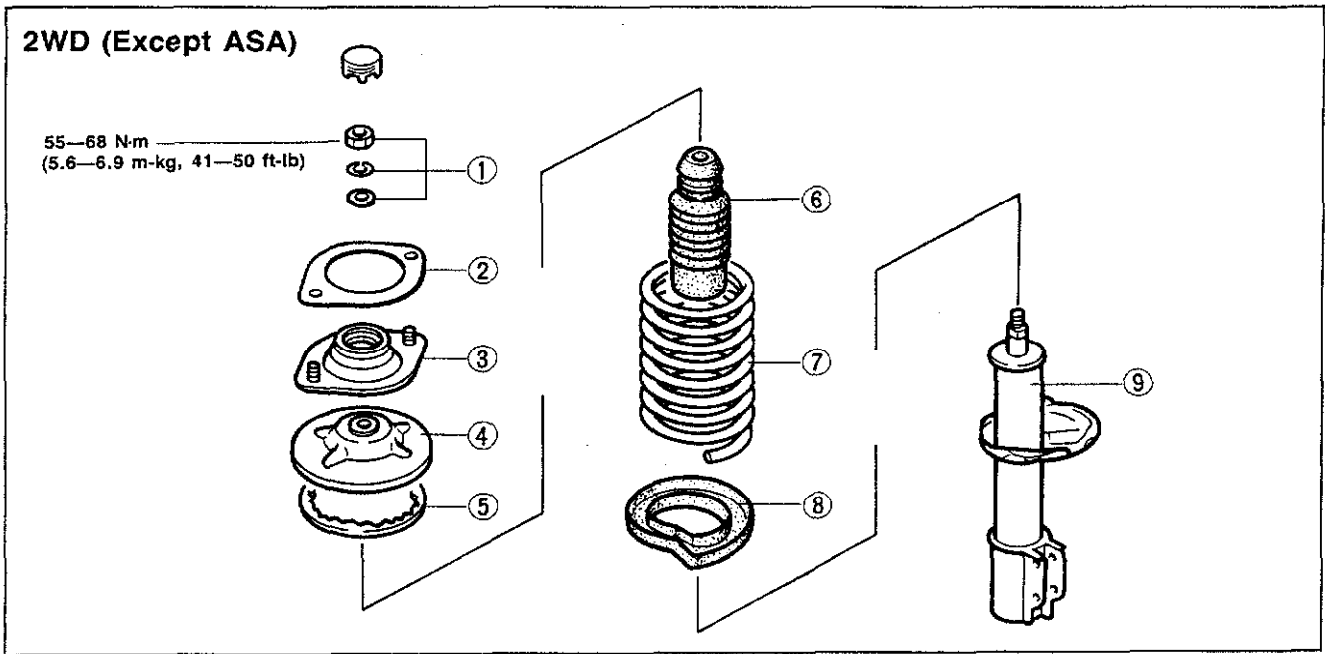

83U13X-010

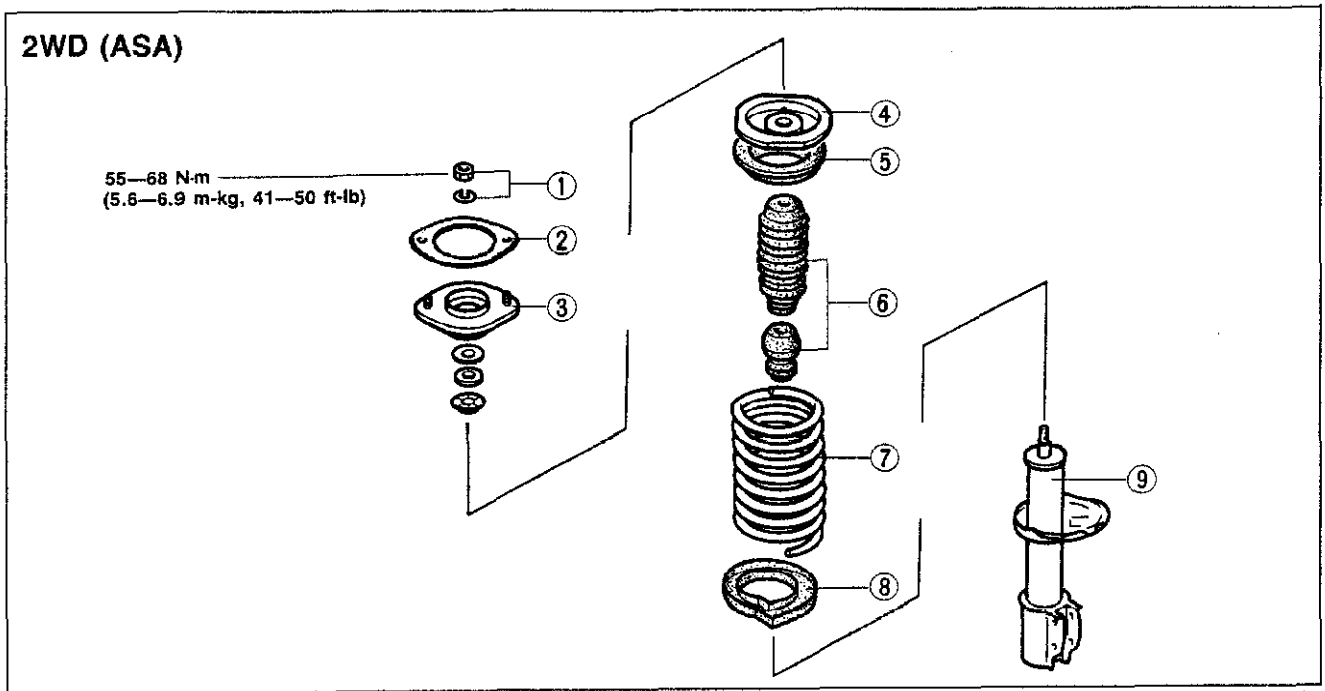

83U13X-011

# 13 FRONT SHOCK ABSORBER AND SPRING

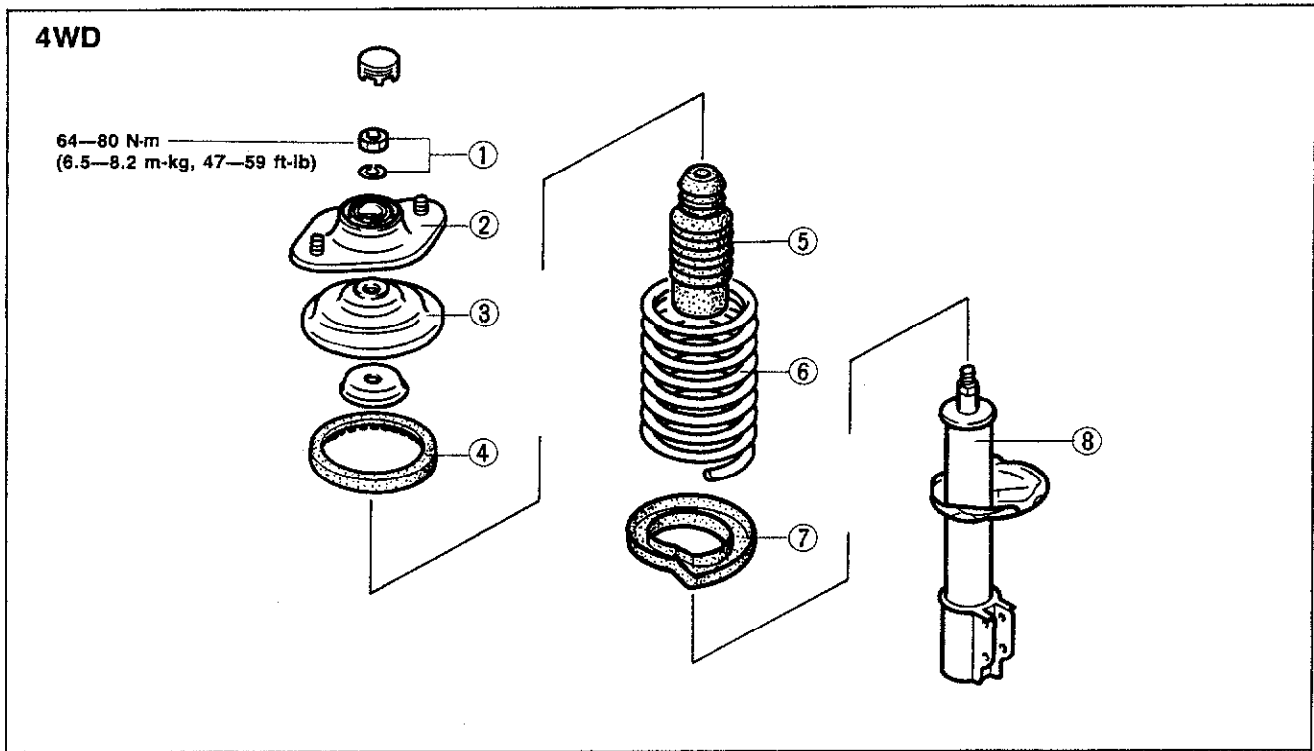

83U13X-012

1. Nut and washer
2. Mounting block
3. Upper spring seat

4. Spring seat
5. Bound stopper
6. Coil spring

7. Lower spring seat
8. Shock absorber

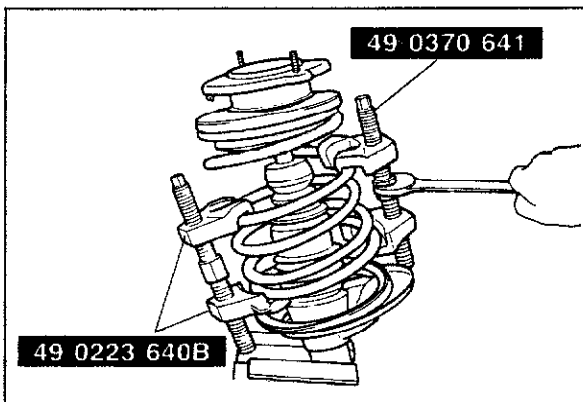

83U13X-013

## Coil Spring Removal:

1. Position the shock absorber mount in a vice.

### Caution

**Insert copper or aluminum plates between the part and the jaws of the vise.**

2. Loosen the piston rod upper nut several turns, but do not remove.

### Caution

**Do not remove the nut.**

3. Compress the coil spring with the **SST** and then remove the nut.
4. Remove the coil spring.

## Installation:

1. Compress the coil spring using **SST**.
2. Install the mounting block in the vise.
3. Tighten the piston rod upper nut.
4. Remove the **SST**.

### Caution

**Check that the spring is well seated in the upper spring seat and lower spring seat.**

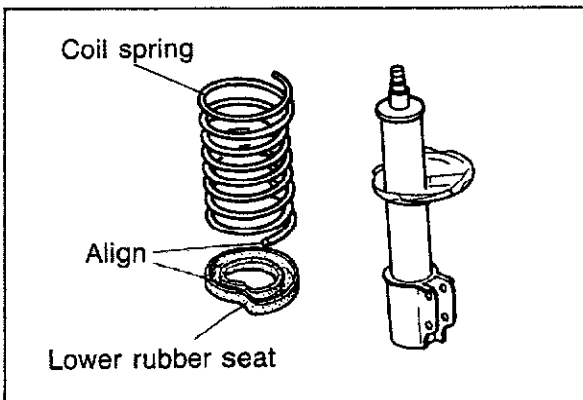

83U13X-014

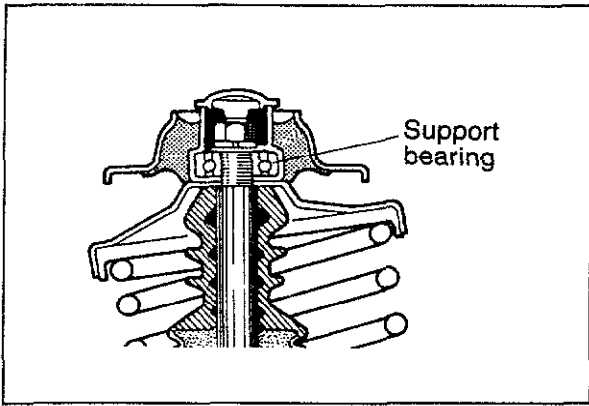

83U13X-015

## Mounting Block

Apply grease to the support bearing of the mounting block before installation.

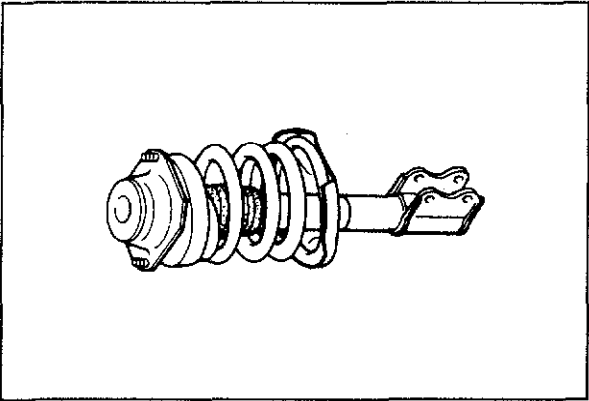

63U13X-009

## INSPECTION

Check the following points, repair or replace if necessary.

1. Oil leakage or abnormal noise from the shock absorbers.
2. Loose installation nuts or bolts of the shock absorbers.
3. Deterioration or damage of the mounting block, bearing looseness.
4. Wear or damage of the bound stopper.

# 13 FRONT LOWER ARM

## FRONT LOWER ARM

### REMOVAL AND INSTALLATION

1. Jack up the front of the vehicle and support it with safety stands.
2. Remove the parts in the numbered sequence shown in the figure.
3. Install in the reverse order of removal.

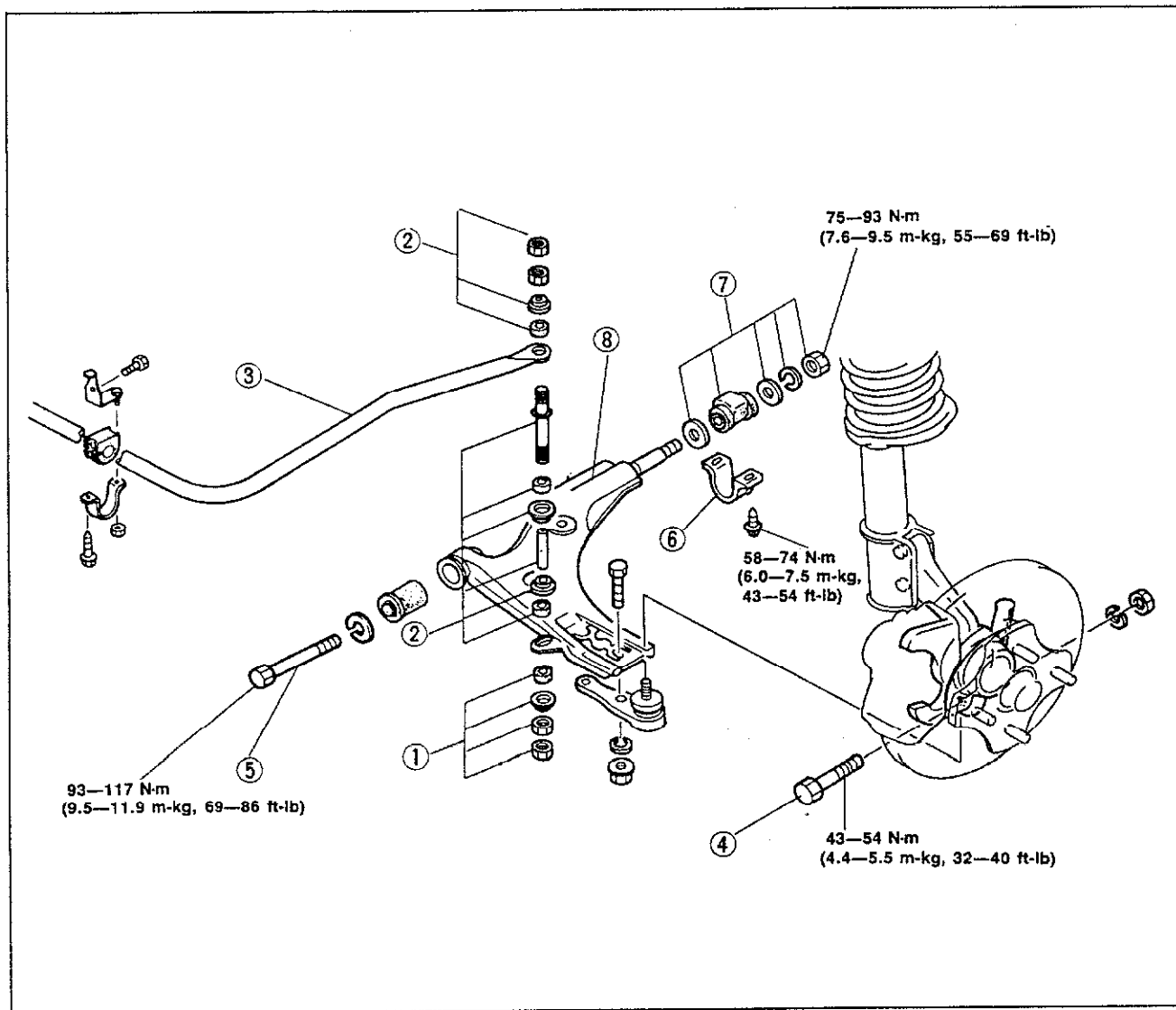

83U13X-016

1. Bolt, bushing and retainer
2. Nut, retainer and bushing
3. Stabilizer (if equipped)

4. Bolt
5. Bolt
6. Bracket

7. Nut, washer and bushing
8. Lower arm

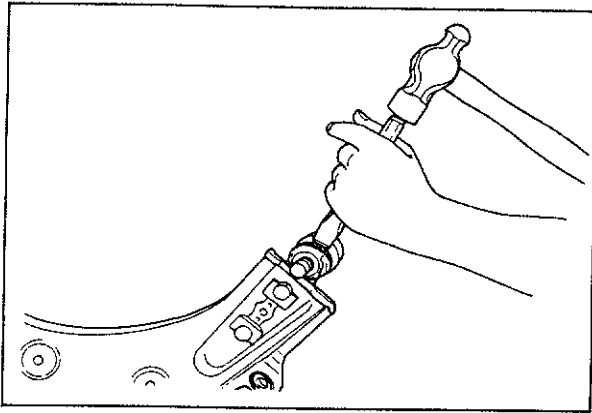

63U13X-013

## Dust boot

### Removal

Use a chisel to remove the dust boot.

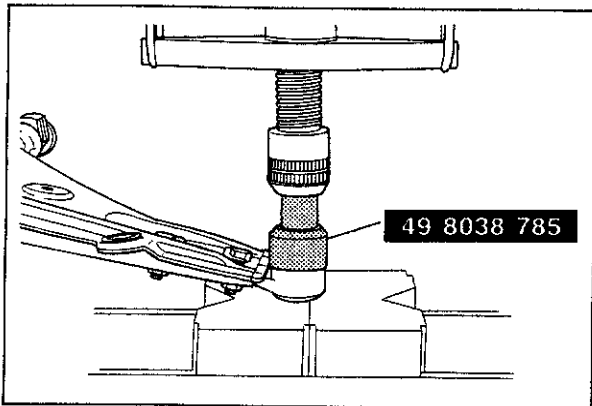

63U13X-014

### Installation

Apply lithium grease to the inside of the new dust boot, and then install it with **SST**.

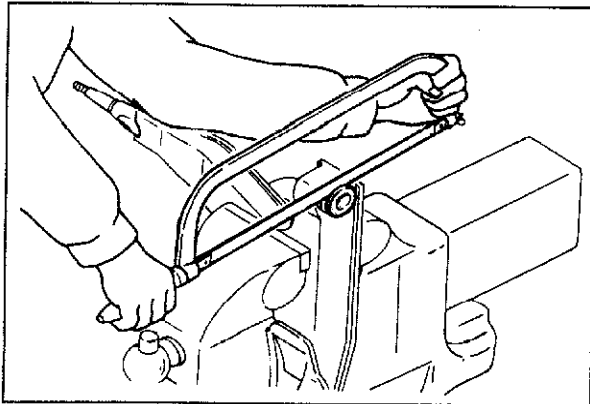

63U13-015

## Lower arm bushing

### Removal

1. Cut away the exposed part of the lower arm bushing.

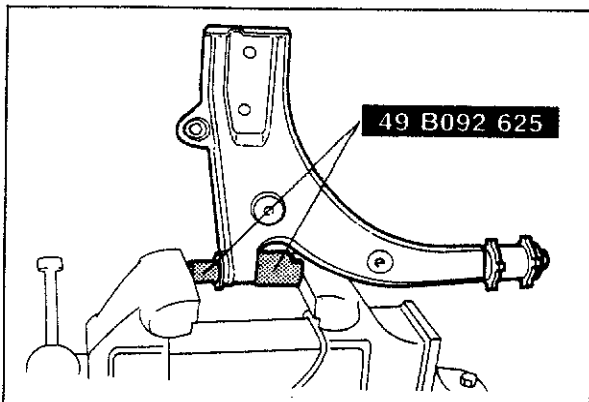

63U13X-016

2. Use **SST** as shown in the figure, and remove the bushing.

# 13 FRONT LOWER ARM

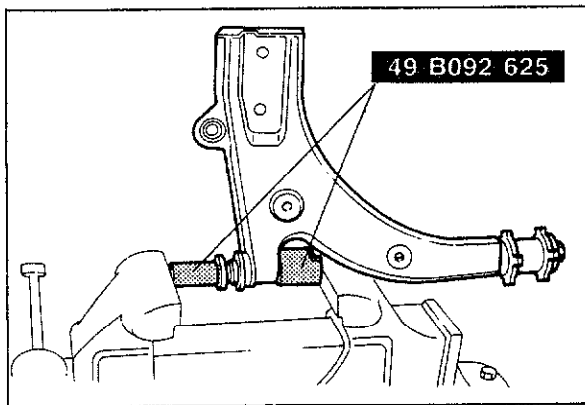

83U13X-042

## Installation

Use **SST** as shown in the figure, and install the bushing.

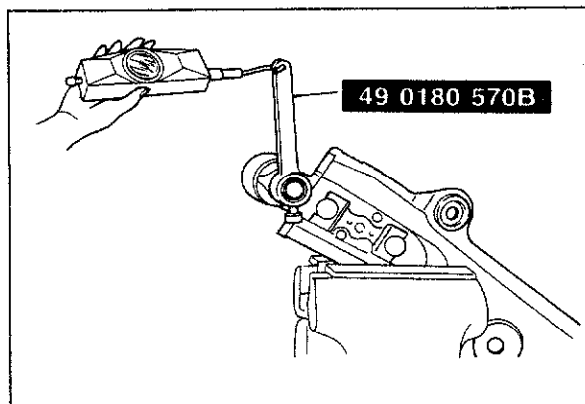

83U13X-017

## Measurement of ball joint rotation torque

Install the **SST** to the ball stud, and then measure by using a pull scale.

**Rotation torque: 1.8—3.1 N·m**  
(18—31 cm·kg, 15.6—26.9 in·lb)

**Pull scale reading:**  
1,800—3,100 kg (3.96—6.82 lb)

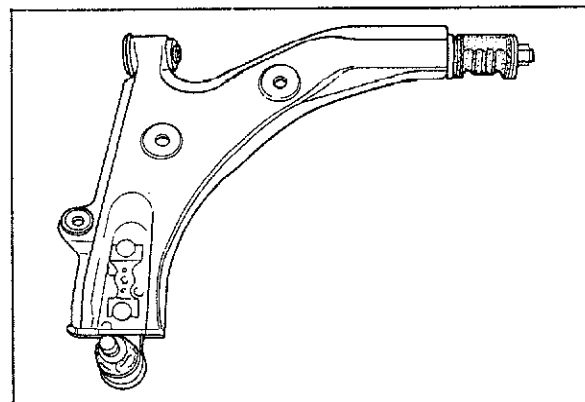

63U13X-018

## INSPECTION

Check the following points, replace if necessary.

1. Deformation or cracks in the lower arm.
2. Deformation or wear of the bushing.
3. Rotation torque of the ball joint.



# FRONT STABILIZER

## REMOVAL AND INSTALLATION

1. Jack up the front of the vehicle and support it with safety stands.
2. Remove the under cover.
3. Remove in the sequence shown in the figure.
4. Install in the reverse order of removal.

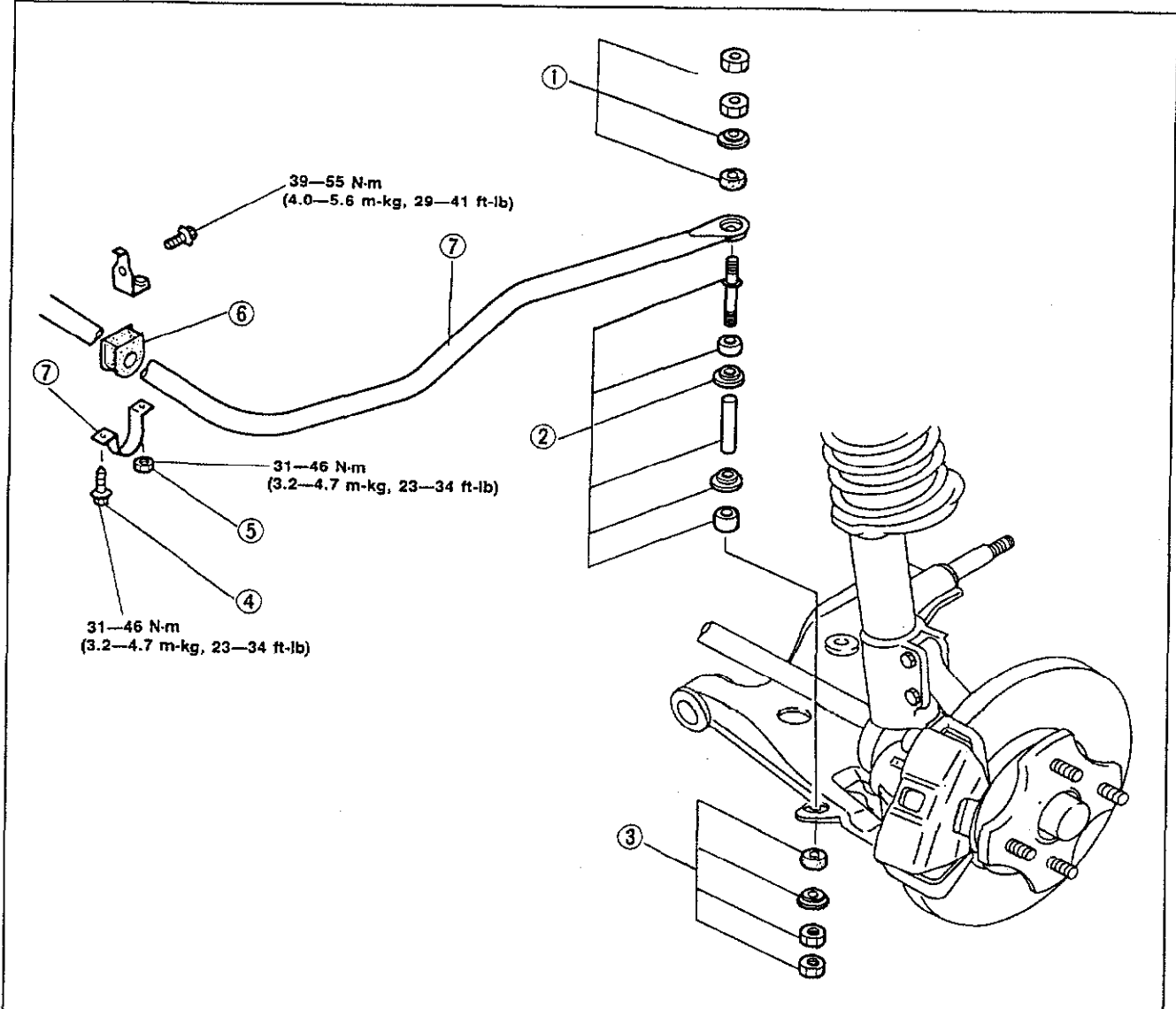

83U13X-018

- |                                 |                               |                        |
|---------------------------------|-------------------------------|------------------------|
| 1. Nut, retainer and bushing    | 3. Bolt, retainer and bushing | 6. Bushing and bracket |
| 2. Bushing, retainer and spacer | 4. Bolt                       | 7. Stabilizer          |
|                                 | 5. Nut                        |                        |

# 13 FRONT STABILIZER

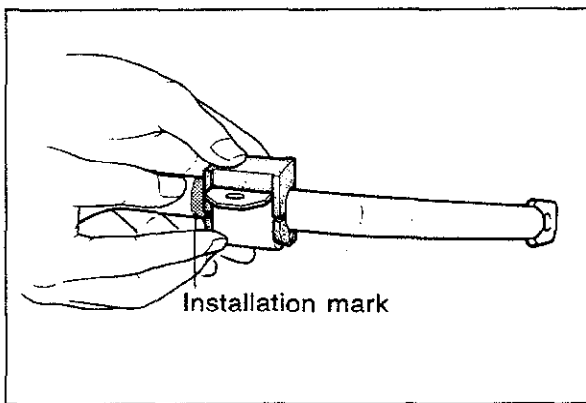

83U13X-019

## Stabilizer Bushing and Bracket

1. Install the bushing with the seam facing forward.
2. Align the bushing with the installation mark painted on the stabilizer.
3. Install the stabilizer bracket and temporarily tighten the bolt.
4. Lower the vehicle and tighten the bolts to the specified torque with the vehicle unloaded.

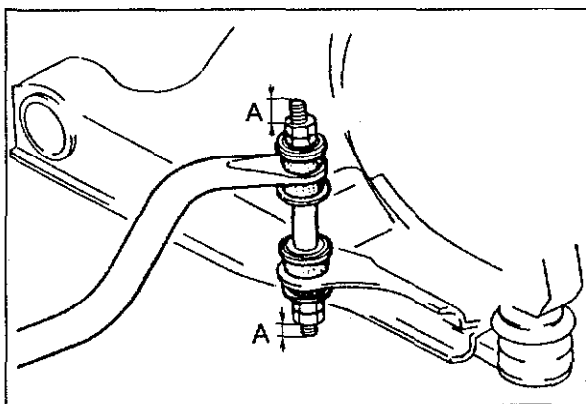

83U13X-020

## Control Link

1. Install the control link to the stabilizer and temporarily tighten the bolts.
2. Lower the vehicle and tighten the nut so that there is **8.5 mm (0.33 in)** of thread (A) exposed at the top or bottom of the control link.

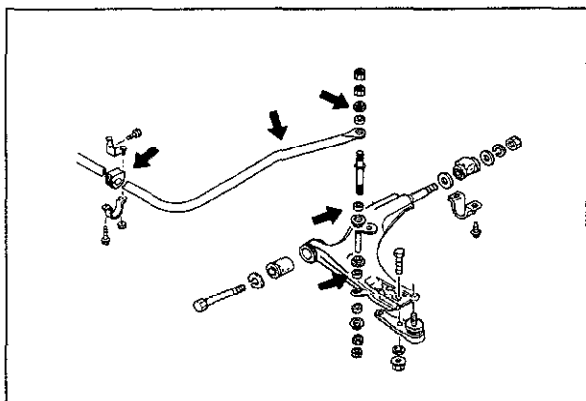

83U13X-021

## INSPECTION

Check the following points. Replace the parts if necessary.

1. Stabilizer for bending or damage.
2. Stabilizer bushing for deterioration or wear.

## REAR SHOCK ABSORBER AND SPRING

### REMOVAL AND INSTALLATION

1. Jack up the rear of the vehicle and support it with safety stands.
2. Remove in the sequence shown in the figure.
3. Install in the reverse order of removal.

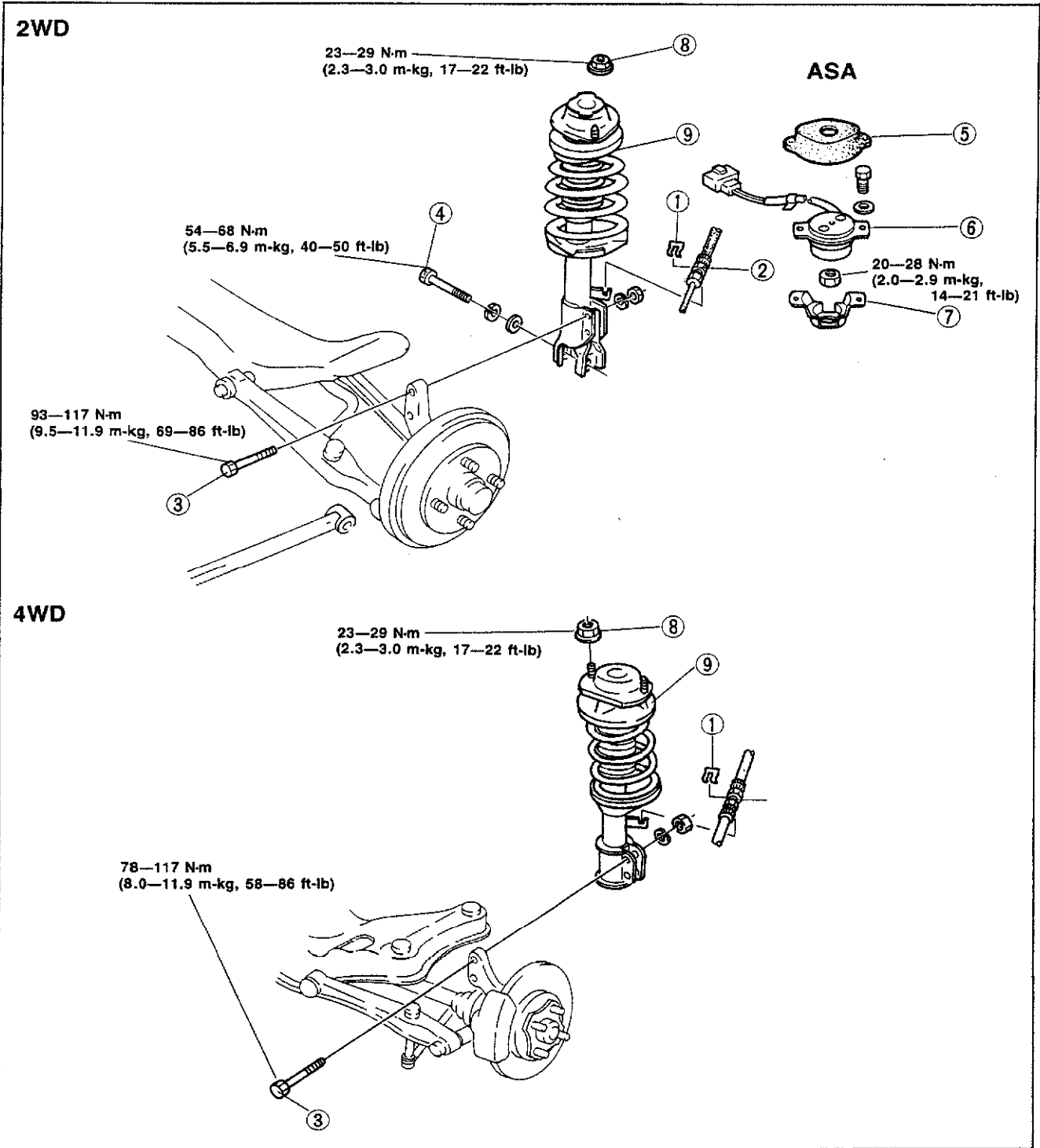

83U13X-022

- |                  |                     |                   |
|------------------|---------------------|-------------------|
| 1. Clip          | 4. Bolt (2WD)       | 7. Bracket (ASA)  |
| 2. Flexible hose | 5. Rubber cap (ASA) | 8. Nut            |
| 3. Bolt          | 6. Actuator (ASA)   | 9. Shock absorber |

# 13 REAR SHOCK ABSORBER AND SPRING

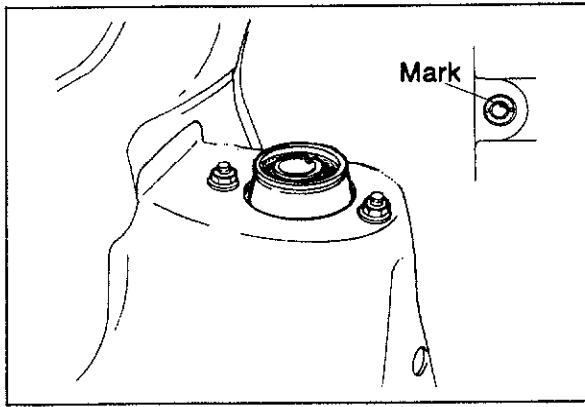

83U13X-009

## Shock Absorber

Install the shock absorber to the suspension tower so that the white mark on the mounting block faces the inside of the vehicle.

## DISASSEMBLY AND ASSEMBLY

1. Disassemble in the sequence shown in the figure.
2. Assemble in the reverse order of removal.

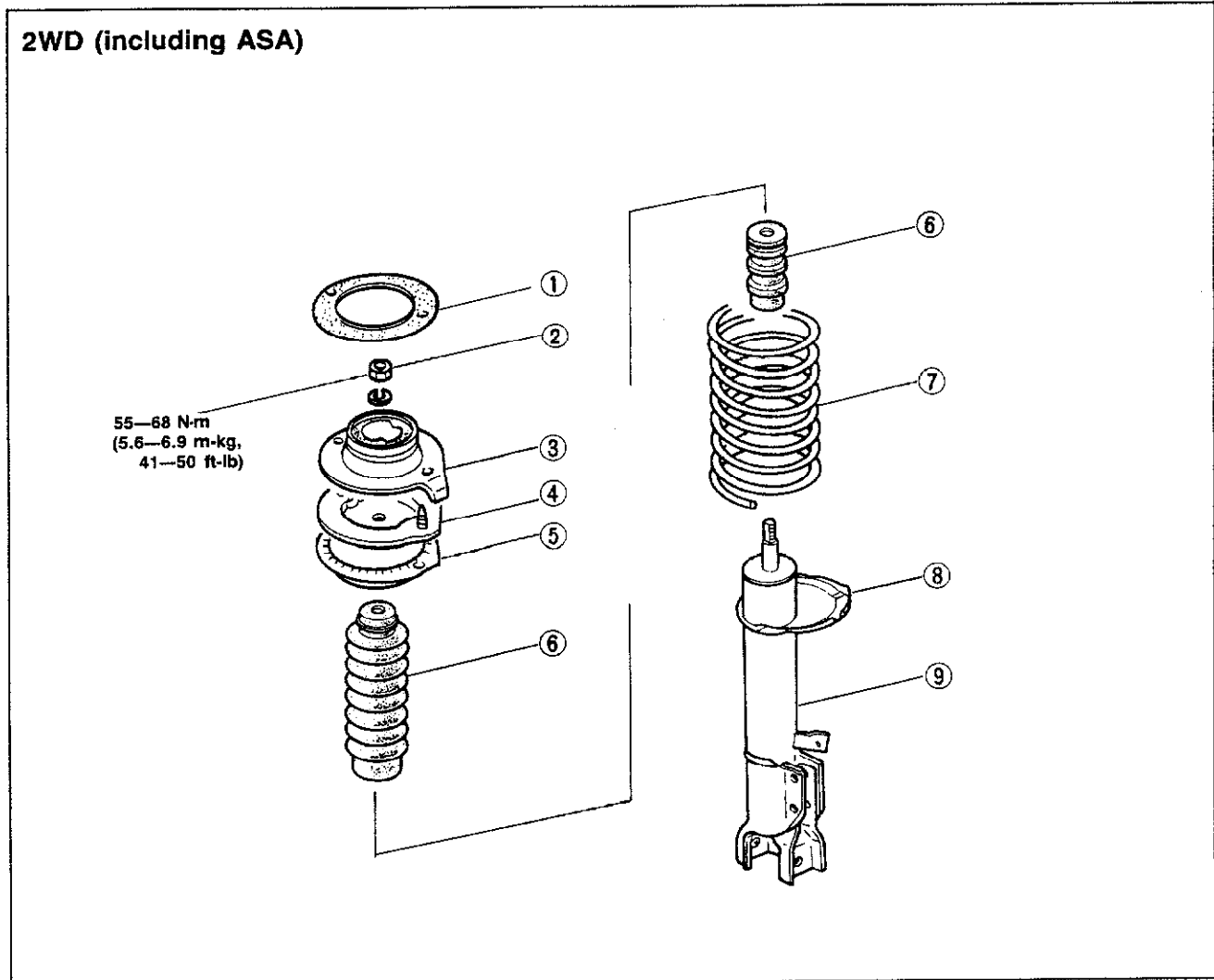

83U13X-023

1. Rubber sheet
2. Nut
3. Mounting block

4. Upper spring seat
5. Spring seat
6. Bound stopper

7. Coil spring
8. Lower spring seat
9. Shock absorber

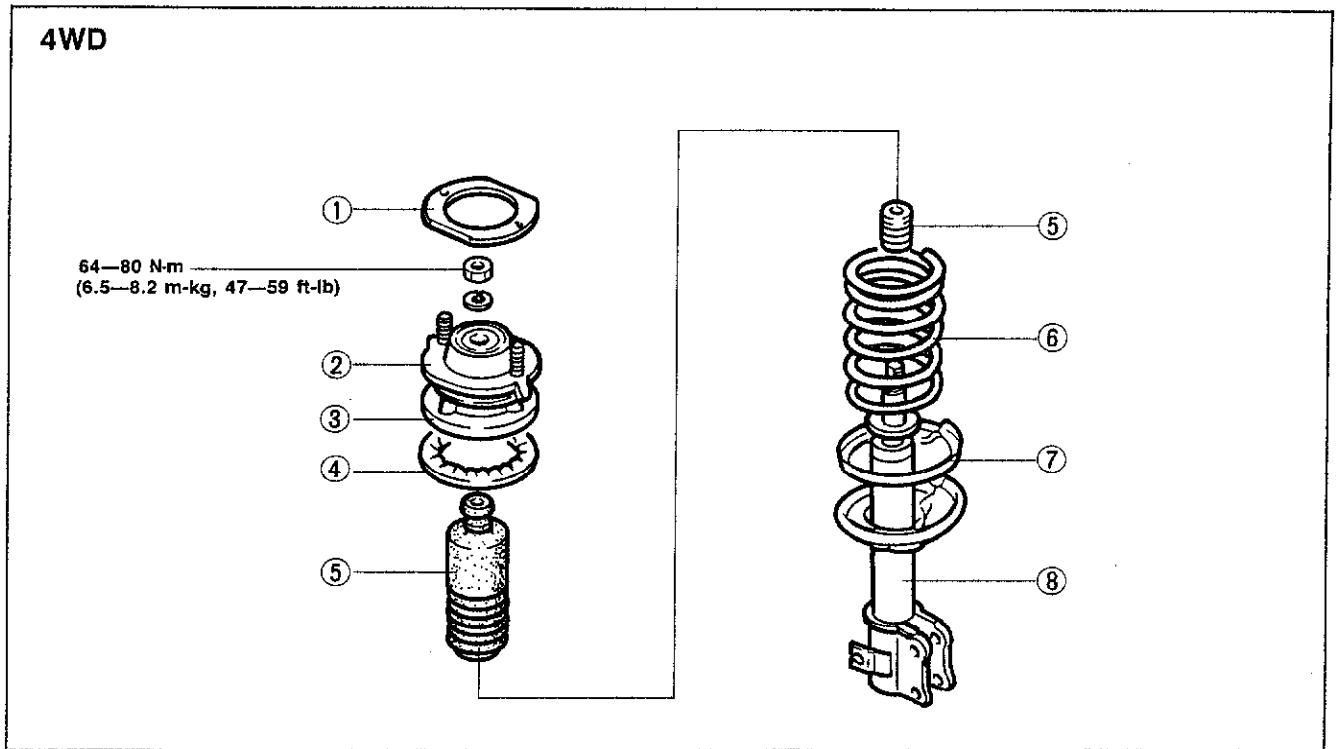

- |                      |                  |                      |
|----------------------|------------------|----------------------|
| 1. Rubber sheet      | 4. Spring seat   | 7. Lower spring seat |
| 2. Mounting block    | 5. Bound stopper | 8. Shock absorber    |
| 3. Upper spring seat | 6. Coil spring   |                      |

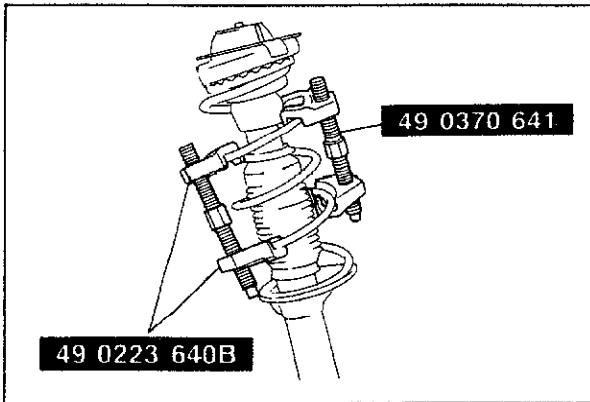

### Coil Spring

#### Removal:

1. Position the shock absorber mount in a vice.

#### Caution

**Insert copper or aluminum plates between the part and the jaws of the vise.**

2. Loosen the piston rod upper nut several turns, but do not remove.

#### Caution

**Do not remove the nut.**

3. Compress the coil spring with the **SST** and then remove the nut.
4. Remove the coil spring.

#### Installation:

1. Compress the coil spring using **SST**.
2. Install the mounting block in the vise.
3. Tighten the piston rod upper nut.
4. Remove the **SST**.

#### Caution

**Check that the spring is well seated in the upper seat and lower seat.**

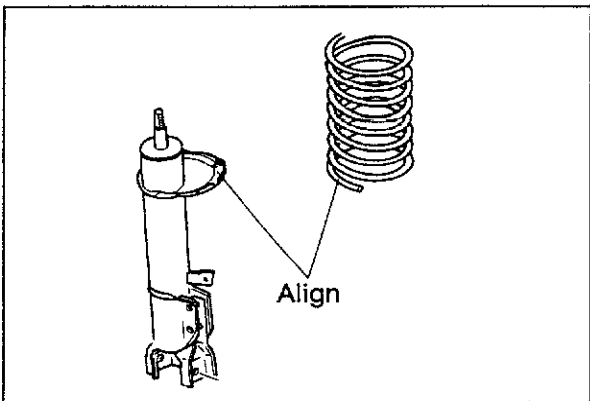

# 13 REAR SHOCK ABSORBER AND SPRING

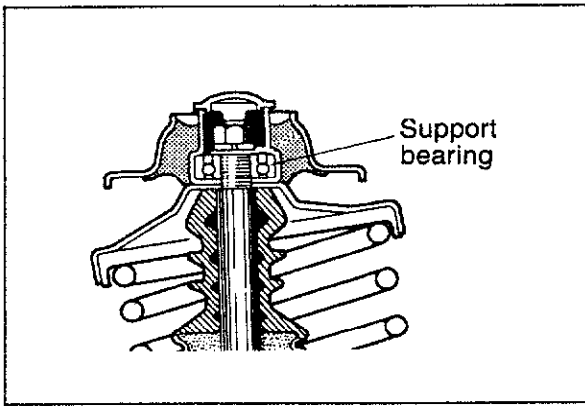

83U13X-015

## Mounting Block

Apply grease to the support bearing of the mounting block before installation.

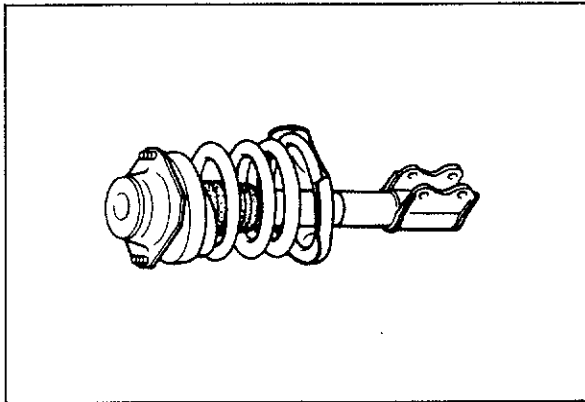

63U13X-009

## INSPECTION

Check the following points, repair or replace if necessary.

1. Oil leakage or abnormal noise from the shock absorbers.
2. Loose installation nuts or bolts of the shock absorbers.
3. Deterioration or damage of the mounting block; bearing looseness.
4. Wear or damage of the bound stopper.

## LATERAL LINK AND TRAILING LINK

### REMOVAL AND INSTALLATION

1. Jack up the rear of the vehicle and support it with safety stands.
2. Remove the parts in the numbered sequence shown in the figure.
3. Install in the reverse order of removal.

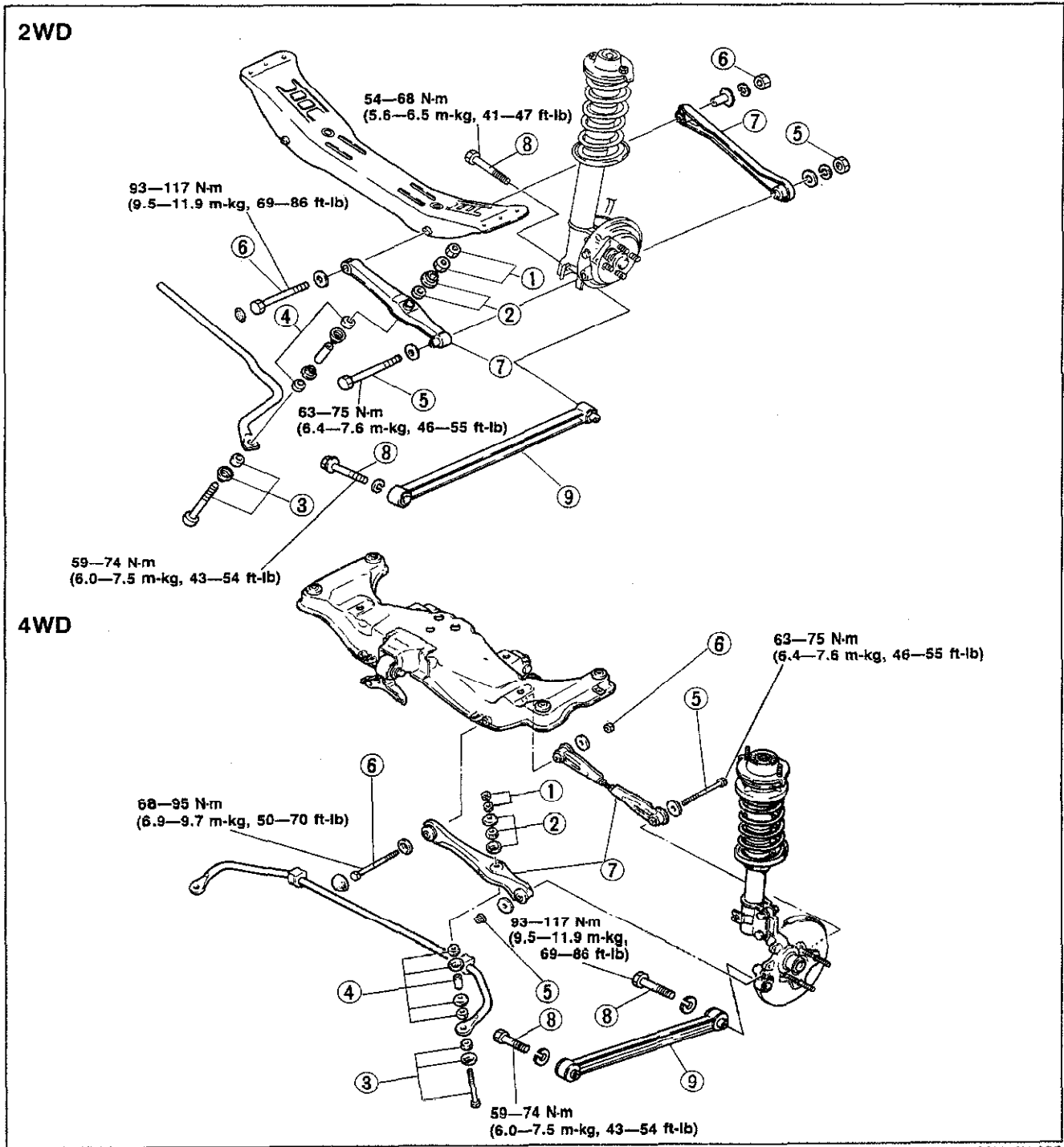

83U13X-025

- |                               |                                 |                  |
|-------------------------------|---------------------------------|------------------|
| 1. Nut                        | 4. Retainer, bushing and spacer | 7. Lateral link  |
| 2. Bushing and retainer       | 5. Bolt and nut                 | 8. Bolt          |
| 3. Retainer, bushing and bolt | 6. Bolt, nut and spacer         | 9. Trailing link |

# 13 LATERAL LINK AND TRAILING LINK, REAR STABILIZER

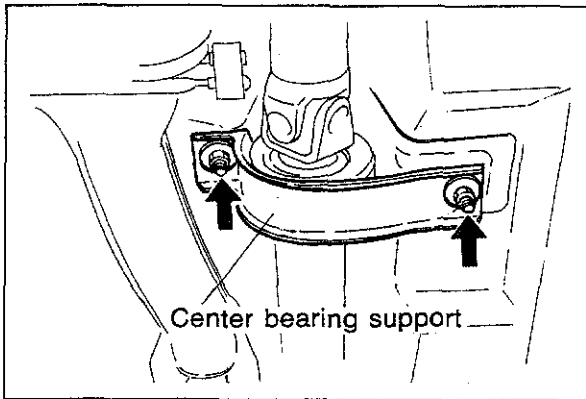

83U13X-026

## Crossmember

Before lowering the crossmember, remove the following parts.

1. Brake pipe clips
2. Center bearing support (4WD)
3. Main silencer hanger (4WD)

## REAR STABILIZER

### REMOVAL AND INSTALLATION

1. Jack up the rear of the vehicle and support it with safety stands.
2. Remove the parts in the numbered sequence shown in the figure.
3. Install in the reverse order of removal.

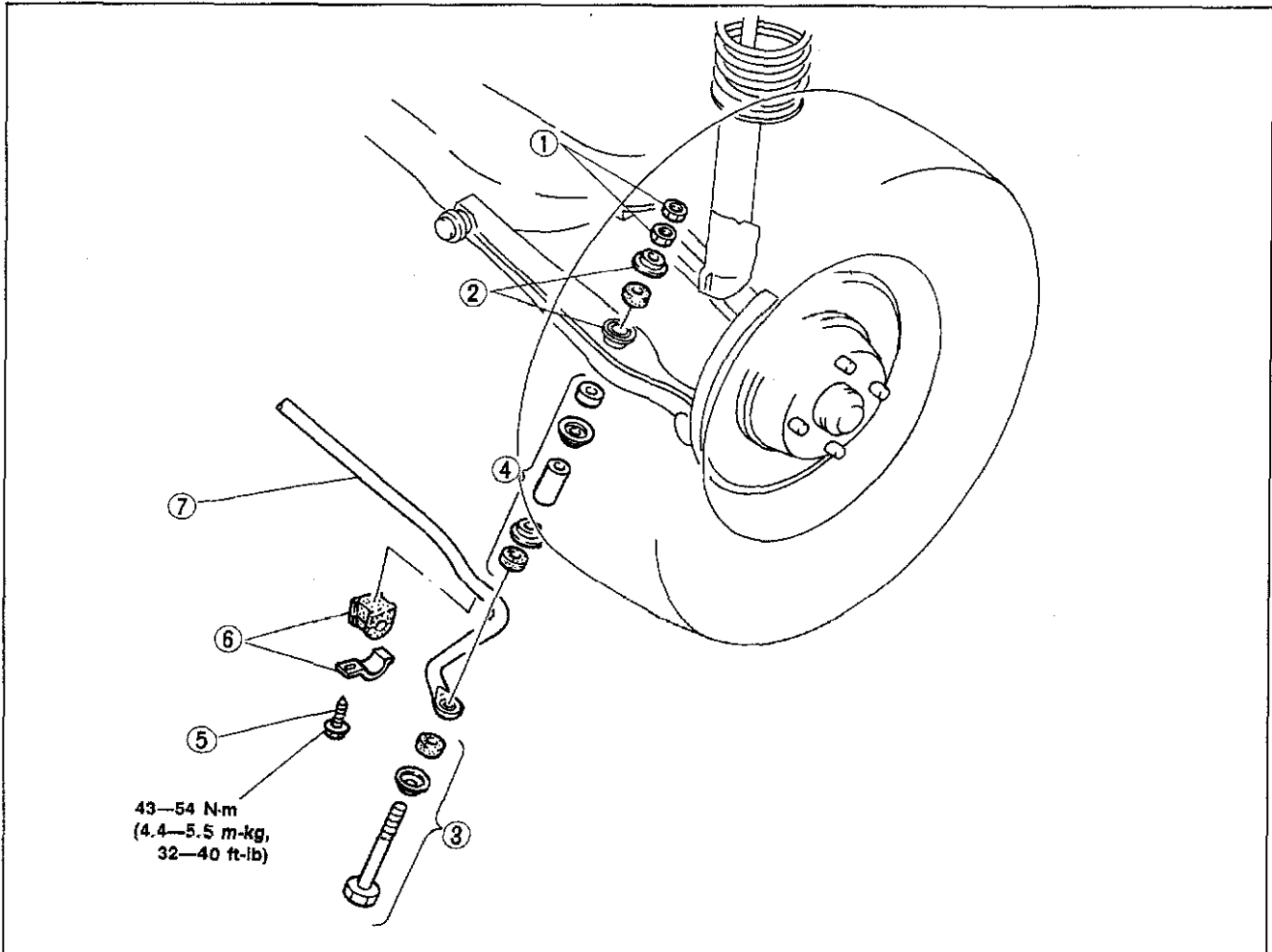

83U13X-027

- |                               |                                  |                        |
|-------------------------------|----------------------------------|------------------------|
| 1. Nut                        | 4. Retainers, bushing and spacer | 6. Bushing and bracket |
| 2. Bushing and retainer       | 5. Bolt                          | 7. Stabilizer          |
| 3. Retainer, bushing and bolt |                                  |                        |



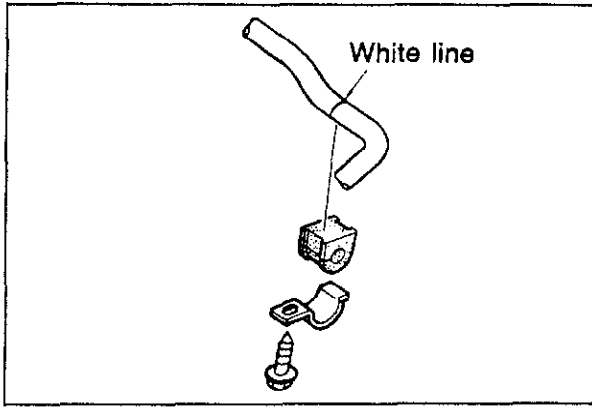

83U13X-028

### Stabilizer Bushing and Bracket

1. Install so that the bushing seam faces toward the front.
2. Align the bushing with the stabilizer painted installation mark.
3. Install the stabilizer bracket and temporarily tighten the bolt.
4. Lower the vehicle and tighten the bolts to the specified torque with the vehicle unloaded.

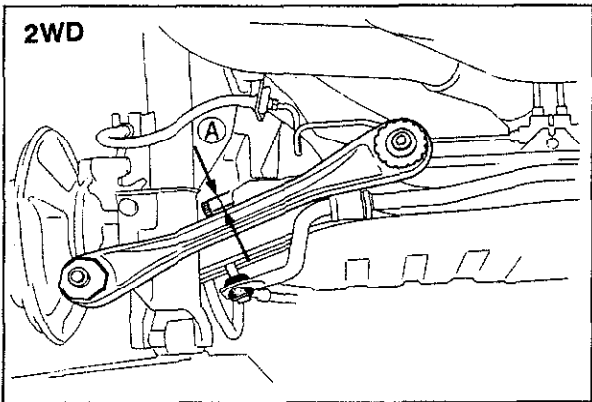

83U13X-029

### Control Link

1. Install the control link to the stabilizer and temporarily tighten the bolts.
2. Lower the vehicle and tighten the nut on the stabilizer bolt so that there is **15 mm (0.59 in)....2WD, 13.4 mm (0.53 in)....4WD** of thread (A) exposed at the top of the bolt.

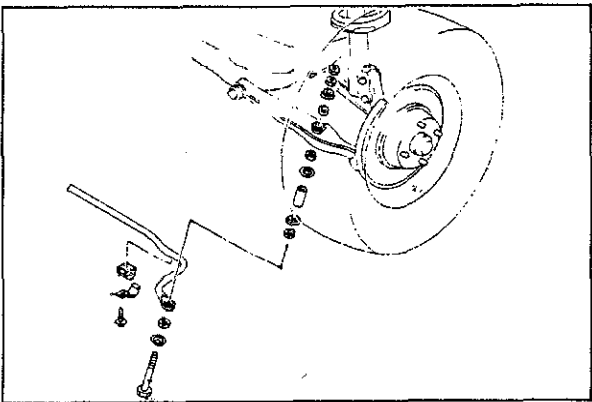
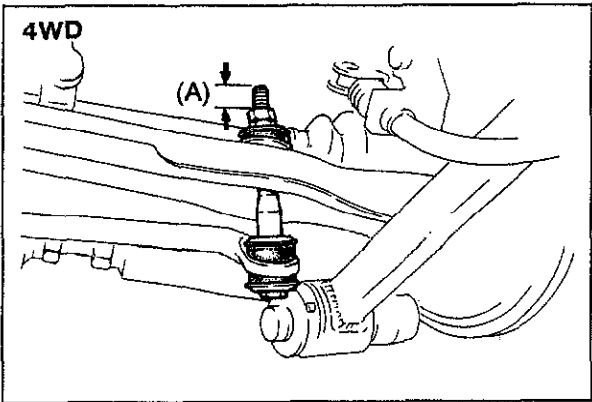

63U13X-036

### INSPECTION

Check the following points, replace if necessary.

1. Worn or deteriorated rubber bushing
2. Bent, deteriorated, or damaged stabilizer

# 13 REAR WHEEL ALIGNMENT

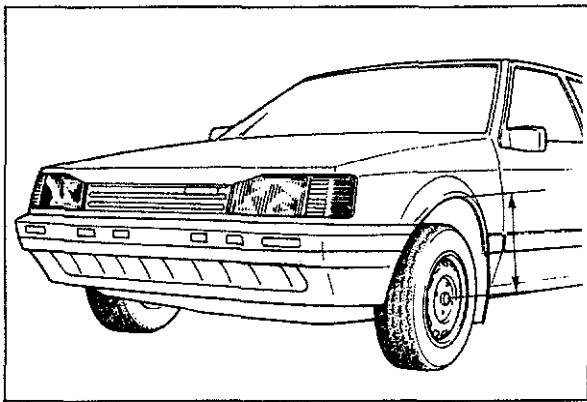

83U13X-030

## REAR WHEEL ALIGNMENT

### PRE-INSPECTION

1. Check the tire inflation and bring to the recommended pressure.
2. Inspect the wheel and tire runout.
3. The vehicle must be on level ground and have no luggage or passenger load.
4. Check that the suspension is correctly adjusted.
5. The difference in height from the center of the wheel to the fender brim between the left and right sides should be **15 mm (0.59 in)** max.

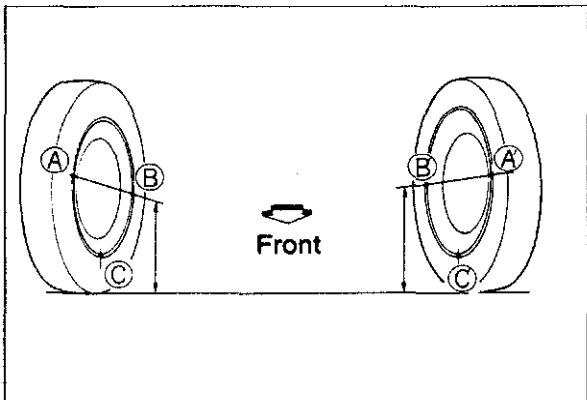

83U13X-031

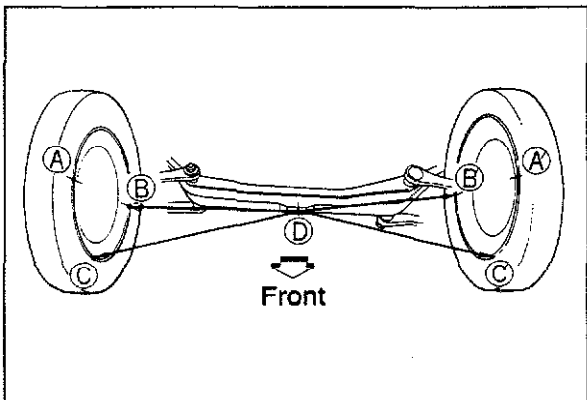

83U13X-032

### TOE-IN

#### a) Pre-inspection and adjustment

1. Place the vehicle on a 4 point or over a pit.
2. Mark the AB and A'B' positions (horizontal, wheel center) of the left and right wheels, and then mark the CC' positions (vertical, center of horizontal).
3. Punch marks to represent D (equidistant from C and C') on the lower part of the crossmember.
4. Measure B-D and B'-D.
5. If the difference between B-D and B'-D is not less than 5 mm (0.2 in), adjust as follows:

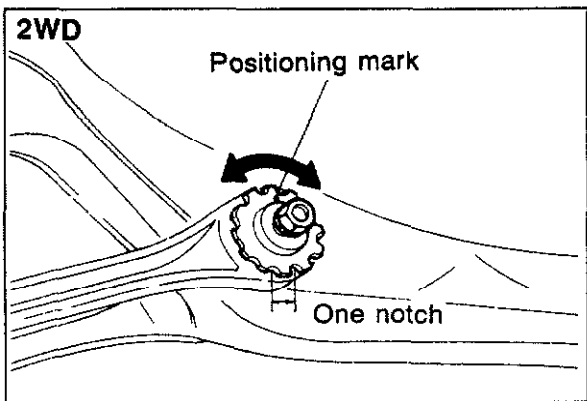

83U13X-033

#### 2WD:

- (1) Loosen the lateral link installation nut.
- (2) Turn either the left or right star wheel.

#### Note

The distance B-D or B'-D changes as follows.

One notch.....2.1 mm (0.083 in)

Two notches.....4.0 mm (0.157 in)

Three notches.....5.2 mm (0.205 in)

- (3) After adjustment, temporarily tighten the lateral link installation nut and tighten it to the specified torque after toe-in adjustment.

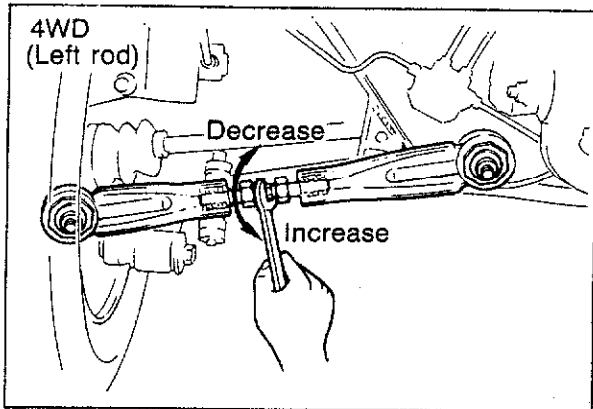

83U13X-034

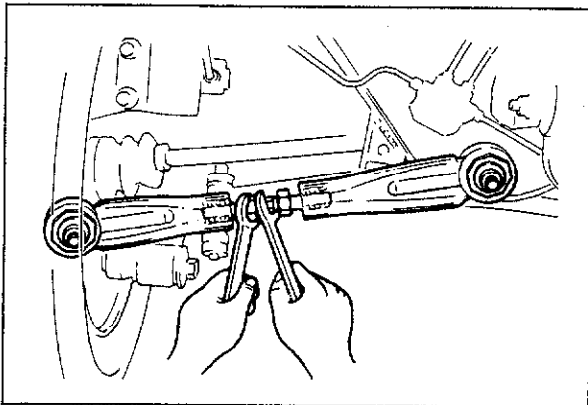

83U13X-035

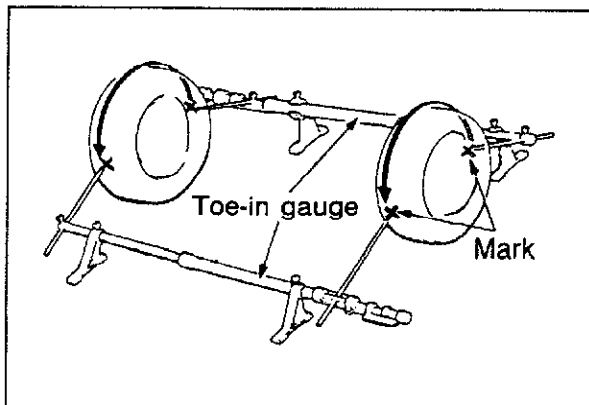

83U13X-036

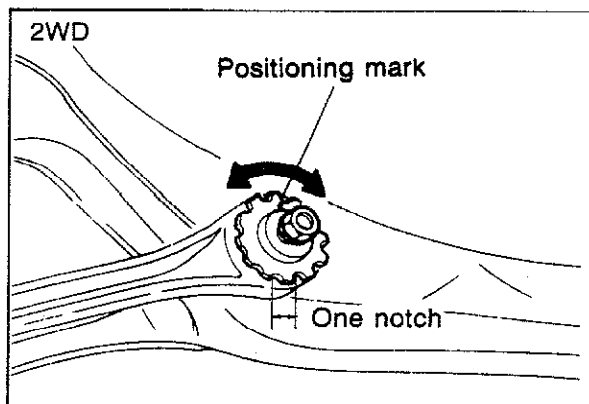

83U13X-037

## 4WD

- (1) Turn the right adjusting rod lock nuts clockwise and turn the left adjusting rod lock nuts counterclockwise to loosen them.
- (2) To increase B—D or B'—D, turn the adjusting rods as follows:  
 Right rod — Turn clockwise  
 Left rod — Turn counterclockwise  
 To decrease B—D or B'—D, turn the adjusting rods as follows:  
 Right rod — Turn counterclockwise  
 Left rod — Turn clockwise

### Caution

**Both the left and right rods must be adjusted by the same amount.**

### Note

**One turn of the adjusting rod (both sides) changes the B—D or B'—D by about 5.6 mm (0.22 in)**

- (3) Temporarily tighten the adjusting locknuts and tighten them after adjusting the toe-in.

## Inspection

1. Raise the rear of the vehicle until the wheels clear the ground.
2. Turn the wheels by hand, and mark a line in the center of each tire tread using a scribing block.
3. Lower the vehicle.
4. Measure the distance between the marked lines at the front and rear of the wheels.

**Toe-in: 0 ± (0 ±<sup>0.20</sup> in)**

## Adjustment

If the toe-in amount is not within specification, adjust as follows:

## 2WD:

- (1) Loosen the lateral link installation nut.
- (2) Turn the left and right star wheels in the same direction.

### Note

**The toe-in amount changes as follows:**

**One notch.....2.1 mm (0.083in)**

**Two notches.....4.0 mm (0.157 in)**

**Three notches.....5.2 mm (0.205 in)**

- (3) After adjustment, tighten the lateral link installation nut to the specified torque (See page 13—19).

# 13 REAR WHEEL ALIGNMENT

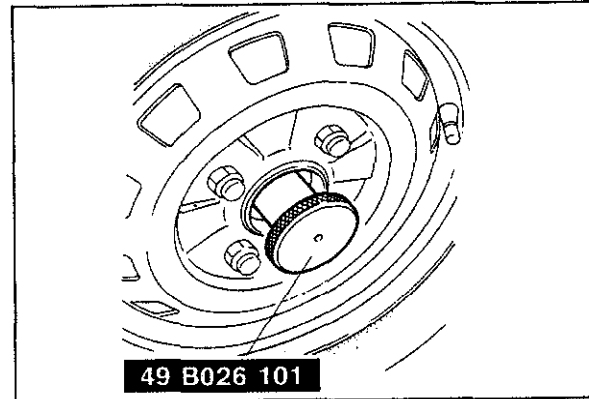
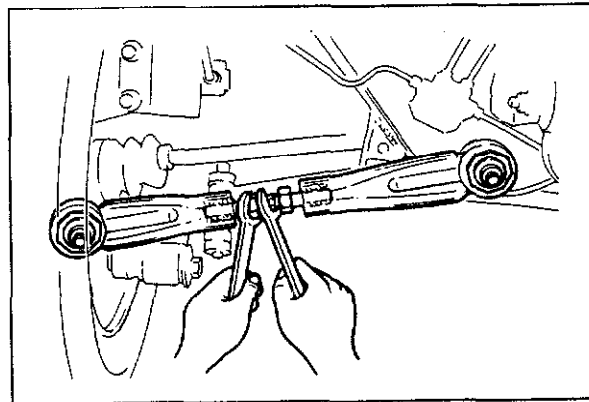
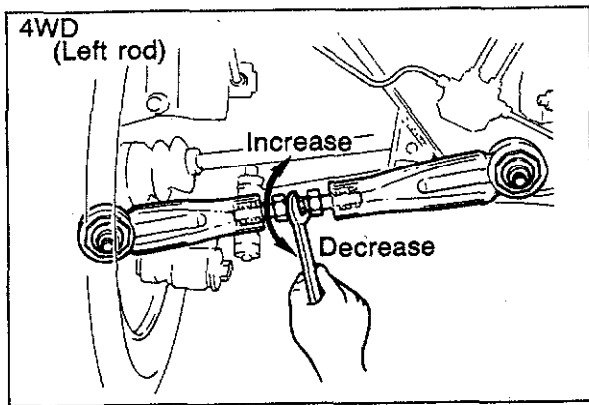

## 4WD:

- (1) Loosen the adjusting rod lock nuts, then adjust the toe-in.
- (2) To increase the toe-in, turn the adjusting rods as follows:  
Right rod — Turn counterclockwise  
Left rod — Turn clockwise  
To decrease the toe-in, turn the adjusting rods as follows:  
Right rod — Turn clockwise  
Left rod — Turn the rod counterclockwise

## Caution

**Both the left and right rods must be adjusted by the same amount.**

## Note

**One turn of the adjusting rod (both sides) changes the toe-in by about 5.6 mm (0.22 in).**

- (3) Tighten the adjusting rod lock nuts to the specified torque.

## Tightening torque:

**55—64 N·m (5.6—6.5 m·kg, 41—47 ft·lb)**

## CAMBER

### Inspection

The right rear hub spindle nut is a left-hand thread, thus **SST** (49 B026 101) is used for the right side. Use **SST** (49 8531 605) for the left side.

**Camber angle: 2WD:  $0^\circ \pm \frac{70'}{20}$**   
**4WD:  $-0^\circ 26' \pm 45'$**

# BODY

<b>HOOD</b> .....	14— 2	REMOVAL AND INSTALLATION....	14—33
REMOVAL AND INSTALLATION.....	14— 2	<b>QUARTER WINDOW GLASS</b>	
ADJUSTMENT.....	14— 2	<b>(5 DOOR HATCHBACK)</b> .....	14—34
<b>TRUNK LID</b> .....	14— 2	REMOVAL AND INSTALLATION....	14—34
REMOVAL AND INSTALLATION.....	14— 2	<b>MOLDING</b> .....	14—35
<b>TRUNK LID STRIKER</b> .....	14— 3	STRUCTURAL VIEW.....	14—35
ADJUSTMENT.....	14— 3	FRONT WINDOW UPPER MOLDING	
<b>COWL PLATE</b> .....	14— 3	AND SIDE MOLDING.....	14—35
REMOVAL AND INSTALLATION.....	14— 3	FRONT DRIP MOLDING.....	14—36
<b>RADIATOR GRILLE</b> .....	14— 3	REAR DRIP MOLDING.....	14—36
REMOVAL AND INSTALLATION.....	14— 3	BELTLINE MOLDING .....	14—36
<b>TRUNK LID REMOTE RELEASE, FUEL</b>		BELTLINE MOLDING	
<b>FILTER LID REMOTE RELEASE</b> .....	14— 4	(3 DOOR HATCHBACK) .....	14—36
REMOVAL AND INSTALLATION.....	14— 4	BELTLINE MOLDING	
<b>FRONT BUMPER</b> .....	14— 5	(5 DOOR HATCHBACK) .....	14—37
REMOVAL AND INSTALLATION.....	14— 5	TRUNK LID MOLDING.....	14—37
<b>REAR BUMPER</b> .....	14— 6	SIDE PROTECTOR MOLDING	
REMOVAL AND INSTALLATION.....	14— 6	(SNAP-IN AND STICK-ON TYPE)..	14—37
<b>HEADLIGHT AND COMBINATION LIGHT</b>	14— 7	SIDE PROTECTOR MOLDING	
REMOVAL AND INSTALLATION....	14— 7	(STICK-ON TYPE) .....	14—38
HEADLIGHT AIMING.....	14— 8	REAR WINDOW MOLDING (SEDAN)	14—39
<b>REAR COMBINATION LIGHT</b> .....	14— 9	BACK DOOR GLASS WINDOW	
REMOVAL AND INSTALLATION....	14— 9	MOLDING (HATCHBACK).....	14—39
REPLACEMENT OF COMBINATION		BUMPER MOLDING.....	14—40
LIGHT LENS .....	14—10	<b>EMBLEM</b> .....	14—40
<b>HIGH MOUNTED STOP LIGHT</b> .....	14—12	MAZDA ORNAMENT .....	14—40
REMOVAL AND INSTALLATION....	14—12	<b>SLIDING SUNROOF</b> .....	14—41
<b>LICENSE PLATE LIGHT</b> .....	14—13	STRUCTURAL VIEW.....	14—41
REMOVAL AND INSTALLATION....	14—13	REMOVAL .....	14—42
<b>INTERIOR LIGHT</b> .....	14—14	INSTALLATION.....	14—43
REMOVAL AND INSTALLATION....	14—14	<b>WINDSHIELD WIPER</b> .....	14—47
<b>FRONT DOOR</b> .....	14—15	REMOVAL AND INSTALLATION....	14—47
STRUCTURAL VIEW.....	14—15	<b>REAR WINDOW WIPER</b> .....	14—49
ADJUSTMENT.....	14—16	REMOVAL AND INSTALLATION....	14—49
<b>FRONT DOOR GLASS AND REGULATOR</b>	14—16	<b>INSTRUMENT PANEL</b> .....	14—51
REMOVAL .....	14—16	REMOVAL AND INSTALLATION....	14—51
INSTALLATION.....	14—17	<b>SEAT</b> .....	14—57
<b>REAR DOOR</b> .....	14—18	DISASSEMBLY AND ASSEMBLY ...	14—57
STRUCTURAL VIEW.....	14—18	INSPECTION.....	14—57
<b>REAR DOOR GLASS AND REGULATOR,</b>		<b>SEAT BELT</b> .....	14—58
<b>QUARTER WINDOW GLASS</b> .....	14—19	REMOVAL AND INSTALLATION....	14—58
REMOVAL .....	14—19	INSPECTION .....	14—58
INSTALLATION.....	14—20	<b>HEAD LINER</b> .....	14—59
INSTALLATION OF DOOR LOCK AND		STRUCTURAL VIEW .....	14—59
OUTER HANDLE .....	14—20	REMOVAL (VEHICLE WITHOUT SUNROOF)	14—61
<b>BACK DOOR</b> .....	14—21	INSTALLATION .....	14—63
REMOVAL AND INSTALLATION....	14—21	REMOVAL (VEHICLE WITH SUNROOF)	14—63
<b>FRONT WINDOW GLASS</b> .....	14—22	INSTALLATION .....	14—65
STRUCTURAL VIEW.....	14—22	<b>FRAME ASSEMBLY OF</b>	
REMOVAL .....	14—23	<b>SLIDING SUNROOF</b> .....	14—65
INSTALLATION.....	14—24	REMOVAL .....	14—65
<b>BACK DOOR GLASS (HATCHBACK)</b>	14—26	INSTALLATION .....	14—65
STRUCTURAL VIEW.....	14—26	<b>ANTENNA FEEDER</b> .....	14—66
REMOVAL .....	14—27	REMOVAL .....	14—66
INSTALLATION.....	14—27	INSTALLATION .....	14—66
<b>REAR WINDOW GLASS</b> .....	14—30	<b>FRONT BODY DIMENSIONS</b> .....	14—67
STRUCTURAL VIEW.....	14—30	<b>UNDERBODY PROJECTED DIMENSIONS</b>	14—68
REMOVAL .....	14—31	<b>UNDERBODY STRAIGHT-LINE</b>	
INSTALLATION.....	14—31	DIMENSIONS.....	14—71
<b>QUARTER WINDOW GLASS</b>			
<b>(3 DOOR HATCHBACK)</b> .....	14—33		

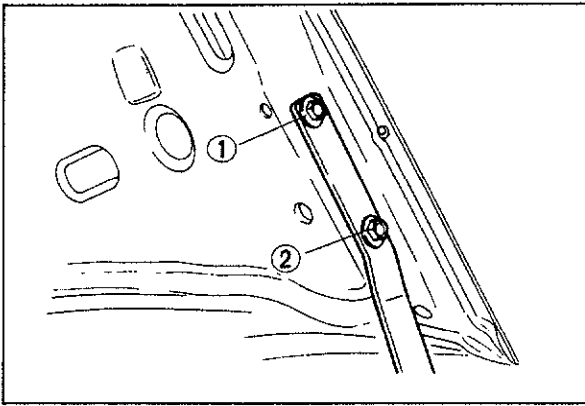

63U14X-002

## HOOD

### REMOVAL AND INSTALLATION

1. Remove the hood following the numbered order.
2. Mark the hood hinge locations on the hood for proper reinstallation.
3. Install the hood in the reverse order of removal. Adjust the hood if necessary.

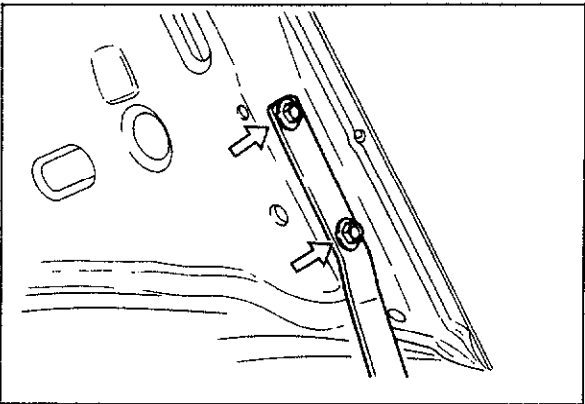

63U14X-003

### ADJUSTMENT

1. Adjust the hood fore-and-aft and side-to side by loosening the nuts attaching the hood to the hinge and repositioning the hood

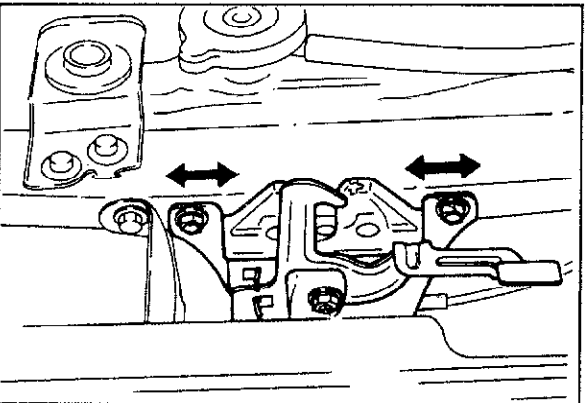

63U14X-004

2. Adjust the hood lock after the hood has been aligned. The hood lock can be moved up-and-down and side-to-side. Align it with the striker on the hood by loosening the attaching bolts.

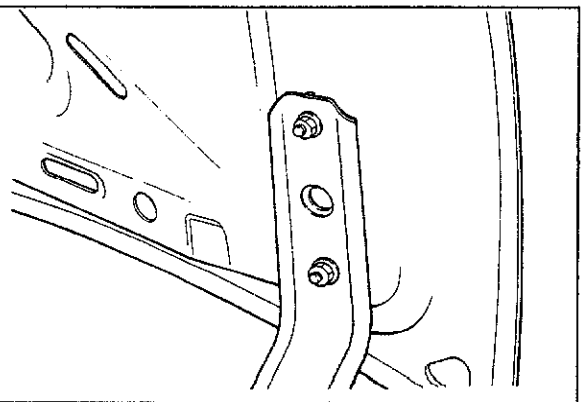

63U14X-005

## TRUNK LID

### REMOVAL AND INSTALLATION

1. Remove the trunk lid installation nuts, and then remove the trunk lid.
2. Installation is the reverse order of removal.
3. When installing, first temporarily tighten the nuts, and then tighten fully after adjusting the alignment with the body.

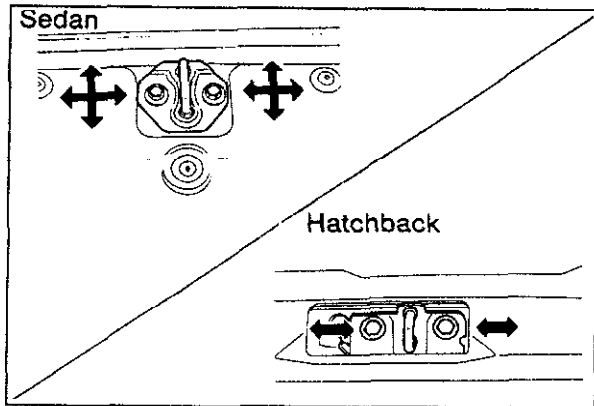

63U14X-006

## TRUNK LID STRIKER

### ADJUSTMENT

Adjust the striker by loosening the installation bolts.

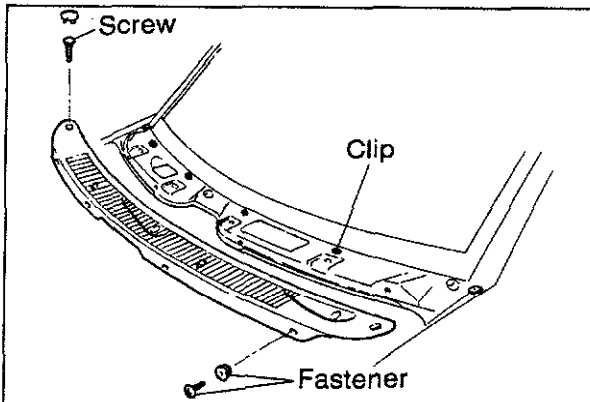

83U14X-002

## COWL PLATE

### REMOVAL AND INSTALLATION

1. Remove the windshield wiper arms.
2. Remove the cowl plate installation screws and fasteners.
3. Open the tabs of the clips with a small screwdrivers: then remove the cowl plate.
4. Install in the reverse order of removal.

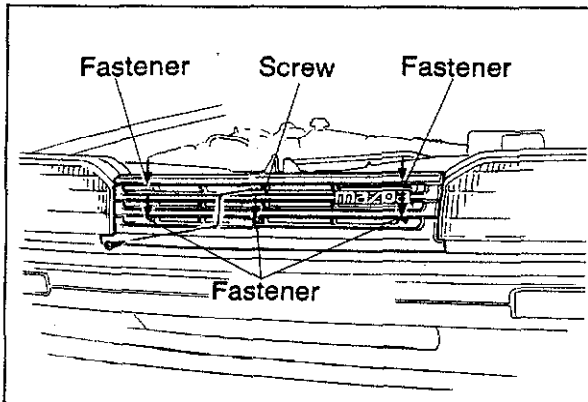

63U14X-008

## RADIATOR GRILLE

### REMOVAL AND INSTALLATION

1. Remove the radiator grille installation screw.
2. Open the tabs of the fasteners with a small screwdriver; and then remove the radiator grille.
3. When installing, insert the fasteners into the grille, and then press them in after aligning them with the installation holes on the body.

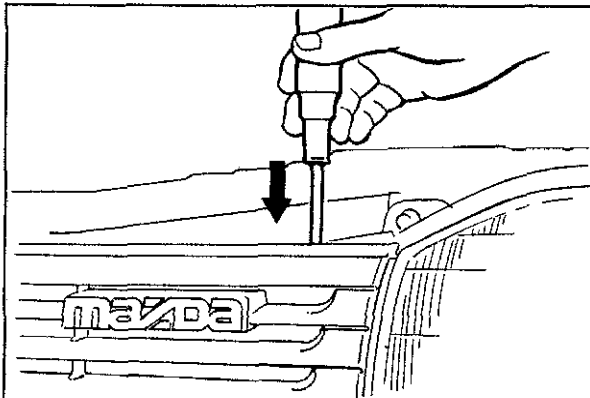

83U14X-003

# 14 TRUNK LID REMOTE RELEASE, FUEL FILLER LID REMOTE RELEASE

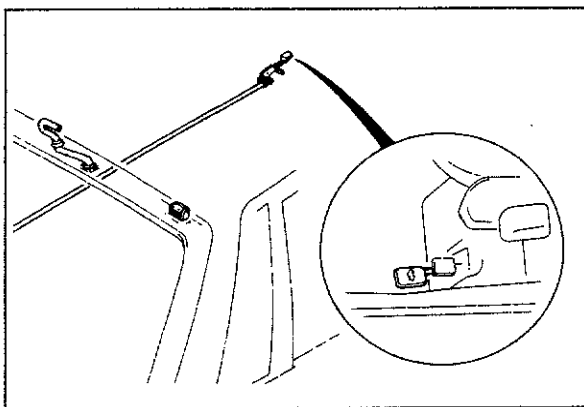

63U14X-010

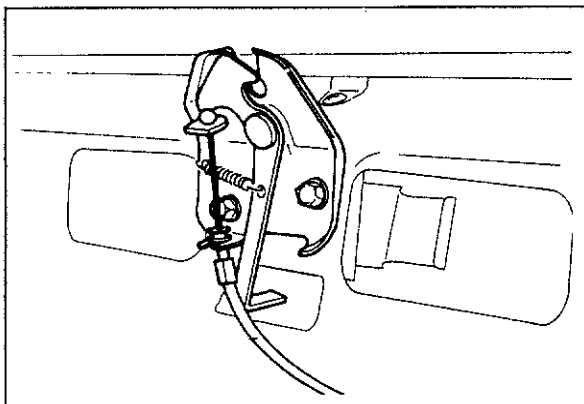

63U14X-011

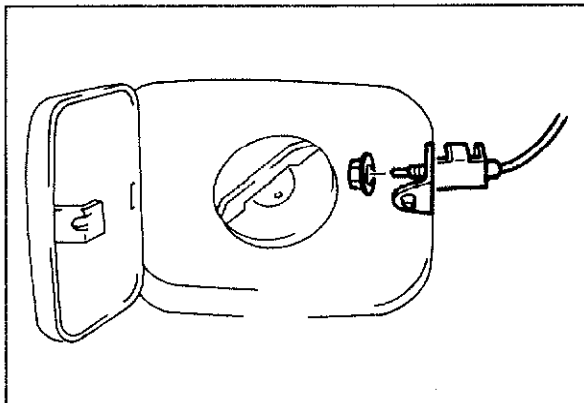

63U14X-012

## TRUNK LID REMOTE RELEASE, FUEL FILLER LID REMOTE RELEASE

### REMOVAL AND INSTALLATION

1. Remove the installation bolt, and then disconnect the trunk lid and fuel lid release wires.
2. Disconnect the release wire from the trunk lid lock.
3. Open the fuel filler lid, remove the installation nut, and then remove the fuel lid opener assembly. Disconnect the release wire from the opener assembly.
4. Install in the reverse order of removal.



## FRONT BUMPER

## REMOVAL AND INSTALLATION

1. Disconnect the battery negative cable.
2. Remove the parts in the sequence shown in the figure, referring to the removal note.
3. Install in the reverse order of removal.

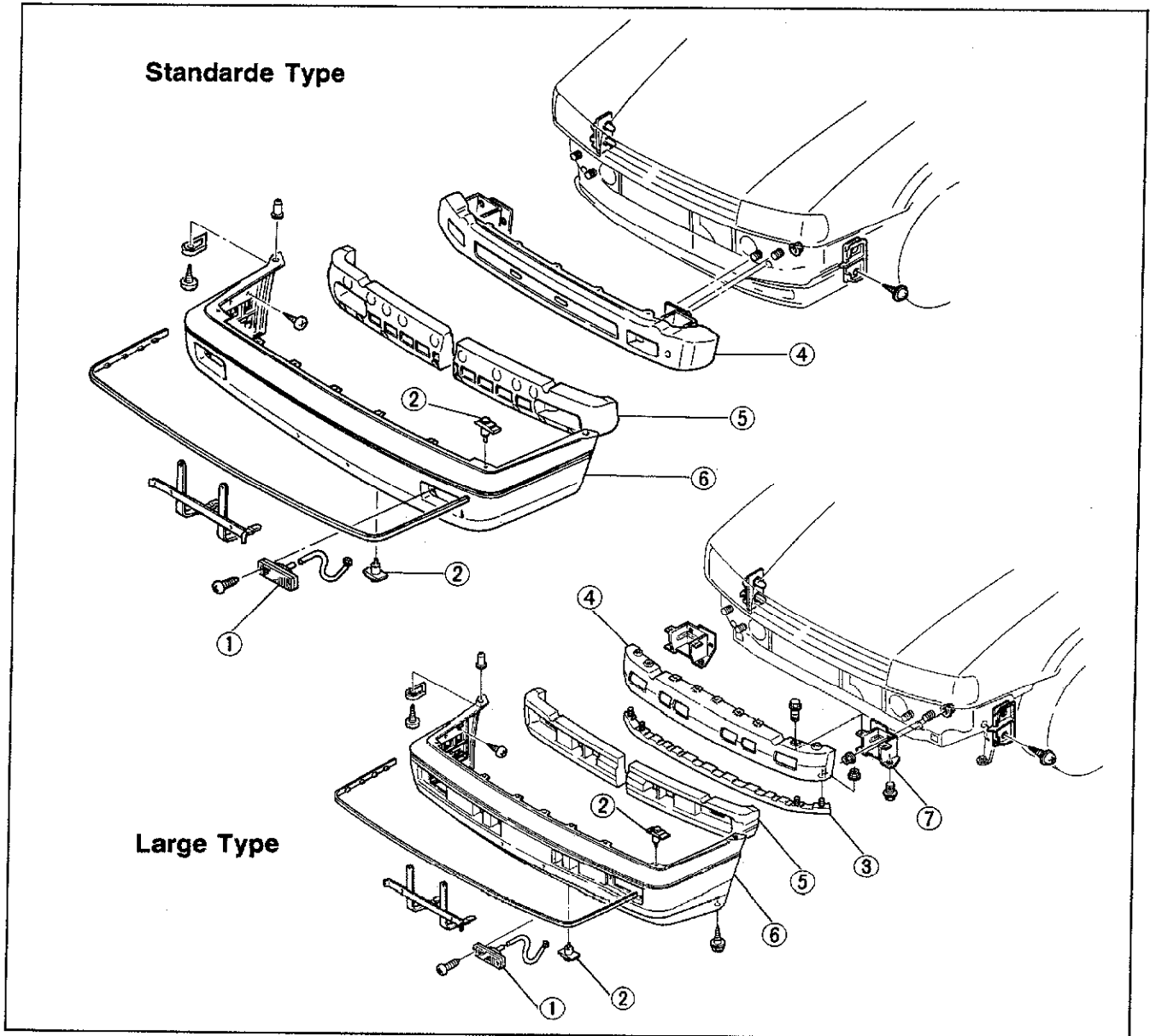

83U14X-004

1. Front turn signal light
2. Fastener
3. Retainer
4. Bumper reinforcement

5. Energy absorbing foam
6. Bumper face
7. Bumper stay

**Removal Note**

When removing the front bumper, remove the headlight first. (Refer to page 14—7)

# 14 REAR BUMPER

## REAR BUMPER

### REMOVAL AND INSTALLATION

1. Remove the parts in the sequence shown in the figure.
2. Install in the reverse order of removal.

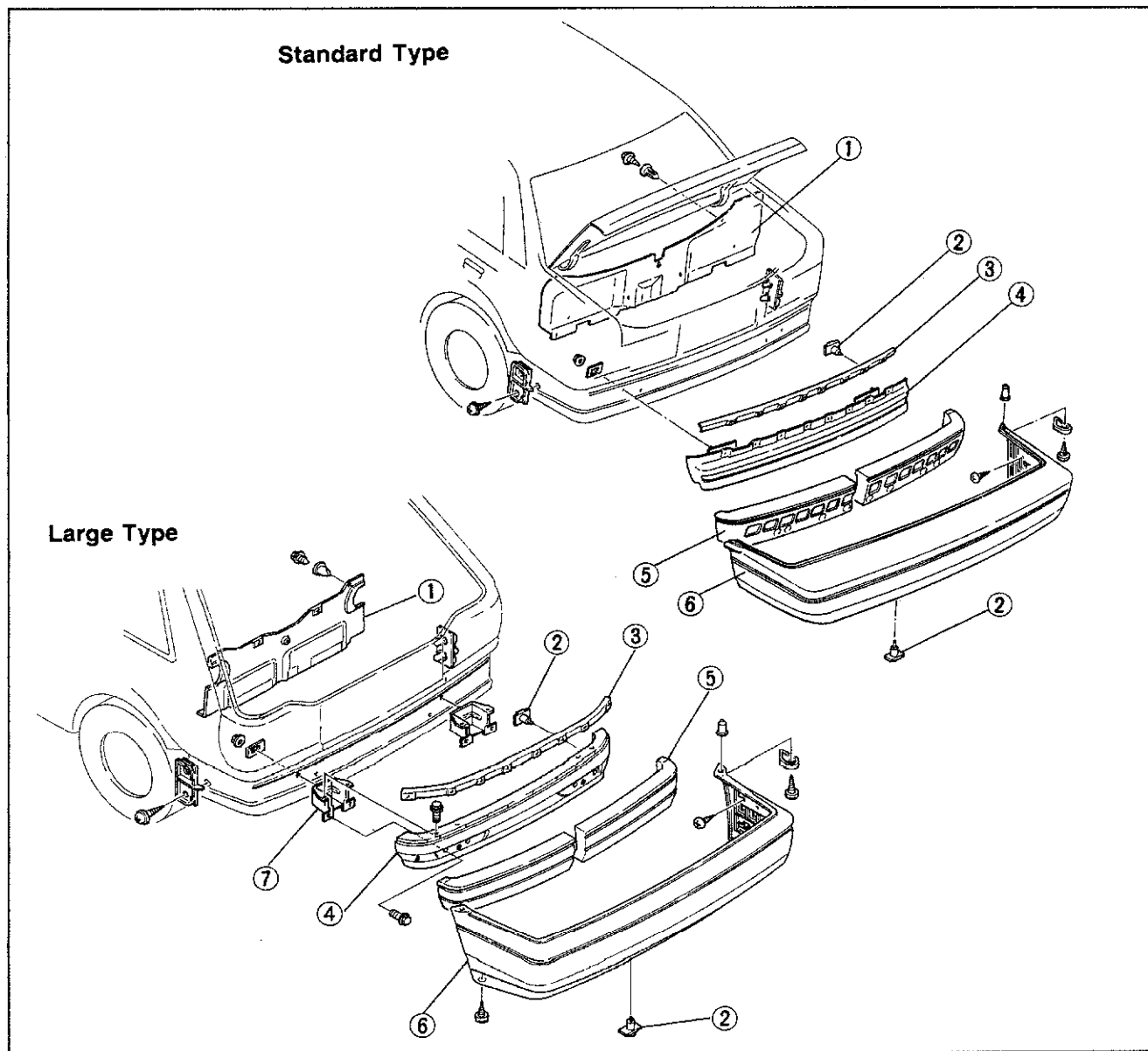

83U14X-005

- |                         |                          |
|-------------------------|--------------------------|
| 1. Trim                 | 5. Energy absorbing foam |
| 2. Fastener             | 6. Bumper face           |
| 3. Retainer             | 7. Bumper stay           |
| 4. Bumper reinforcement |                          |

## HEADLIGHT AND COMBINATION LIGHT

### REMOVAL AND INSTALLATION

1. Disconnect the battery negative cable.
2. Remove the parts in the sequence shown in the figure, referring to the removal note.
3. Install in the reverse order of removal

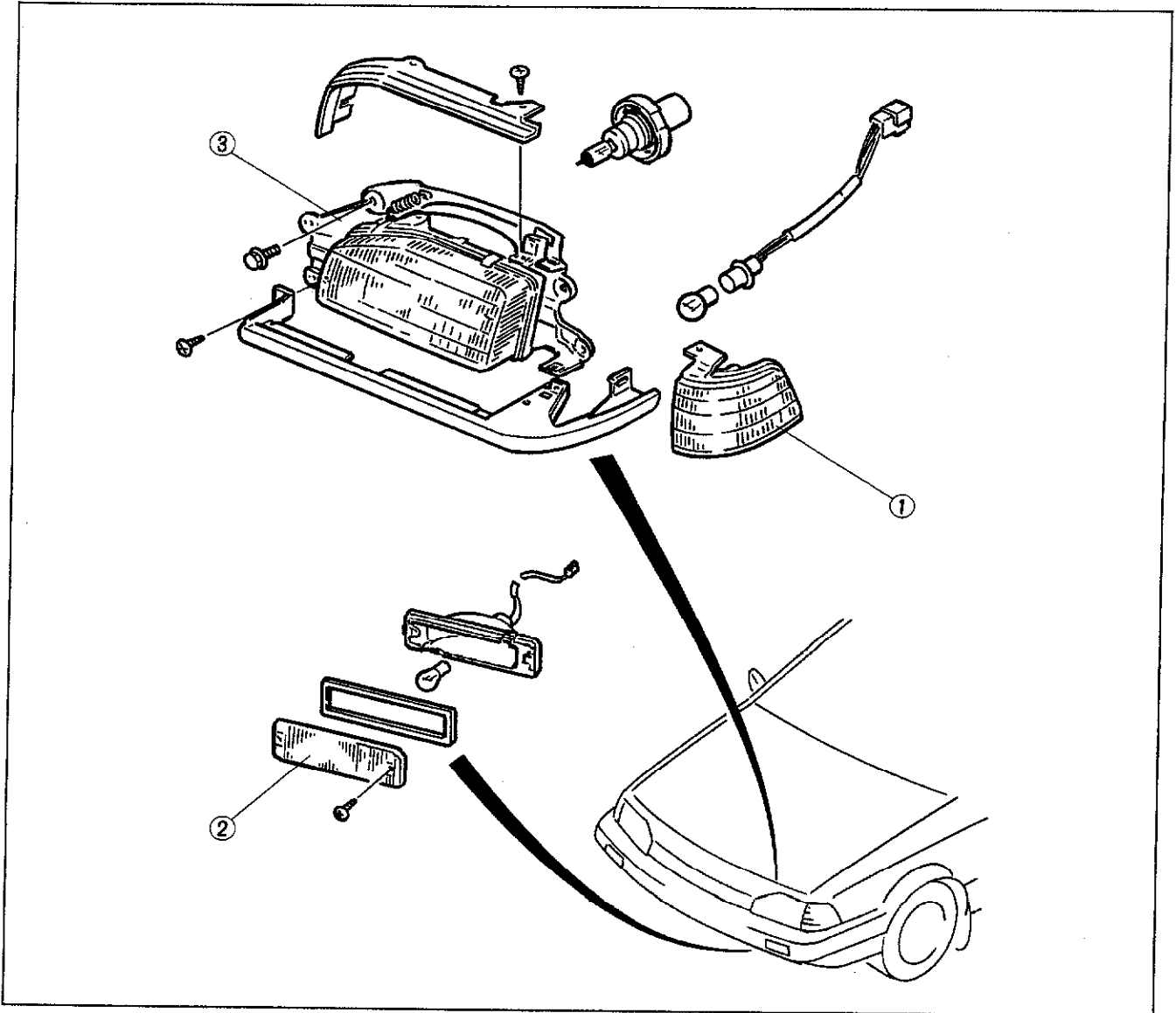

83U14X-006

1. Combination light

2. Turn and hazard light

3. Headlight

Light	Wattage (Bulb Trade Number)
Headlight (Halogen)	65/45 (9004)
Front turn signal light	27 (1156)
Front side marker and parking light	8 (67)

#### Removal Note

**When removing the headlight, remove the radiator grille first. (Refer to page 14—3)**

# 14 HEADLIGHT AND COMBINATION LIGHT

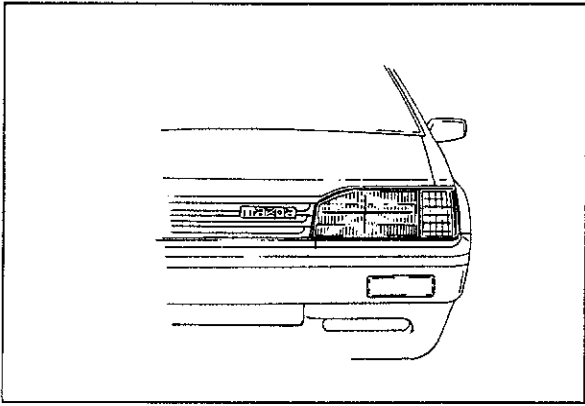

73U14X-003

## HEADLIGHT AIMING

### Preparation

1. Adjust the tires to the standard pressure.
2. Position the vehicle on a flat level surface (unloaded condition).

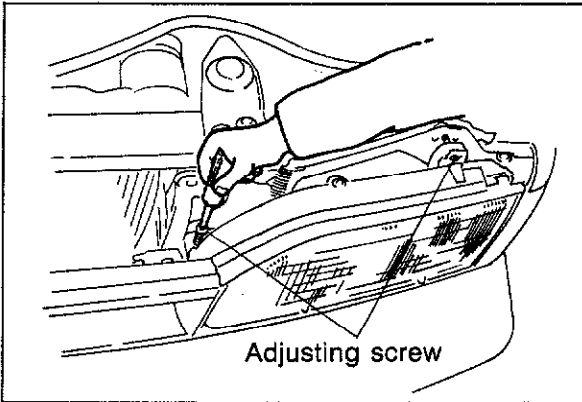

73U14X-004

### Adjustment

Adjust the headlights to meet the local regulations. To adjust, turn the two adjusting screws.

## REAR COMBINATION LIGHT

### REMOVAL AND INSTALLATION

1. Disconnect the negative battery cable.
2. Remove the parts in the sequence shown in the figure, referring to the removal note.
3. Install in the reverse order of removal.

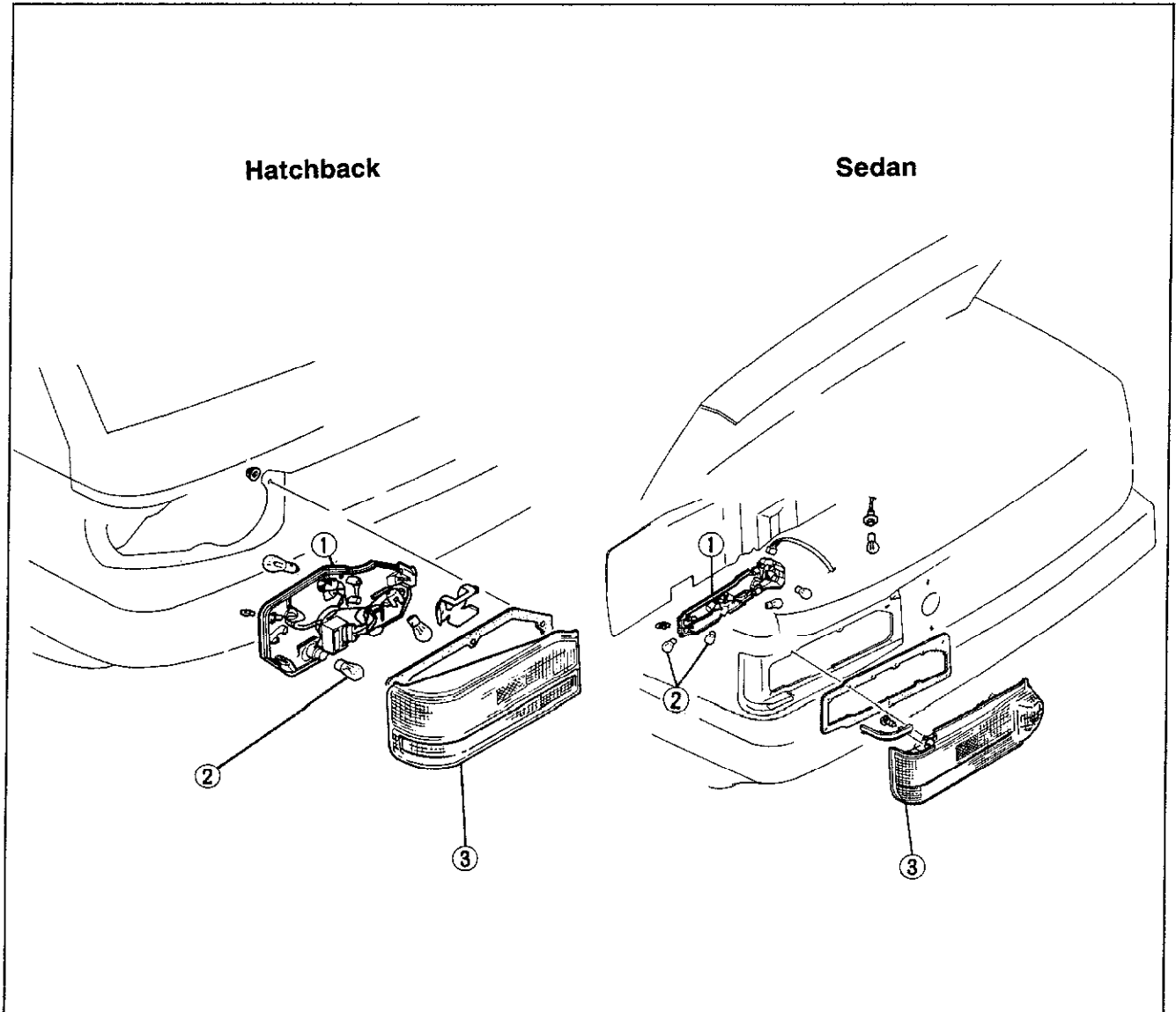

83U14X-007

1. Cover

2. Bulb

3. Lens

Light	Wattage (Bulb Trade Number)
Turn signal lights	27 (1157 NA)
Stop and tail lights	27/8 (1157)
Side marker lights	4.9 (168)
Back-up lights	27 (1156)
License plate lights (For sedan)	8 (67)

#### Removal Note

When removing the combination light from the hatchback model, remove the license plate light first. (Refer to page 14—13)

# 14 REAR COMBINATION LIGHT

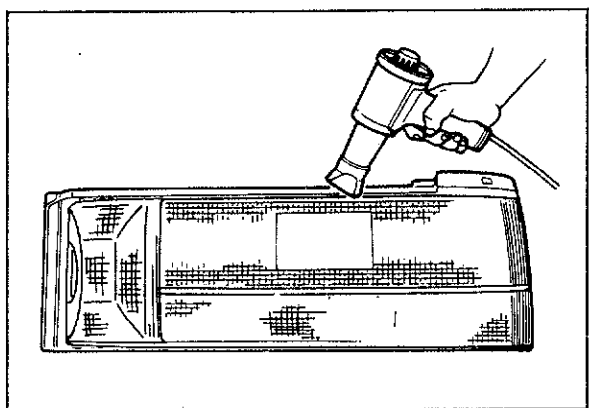

63U14X-018

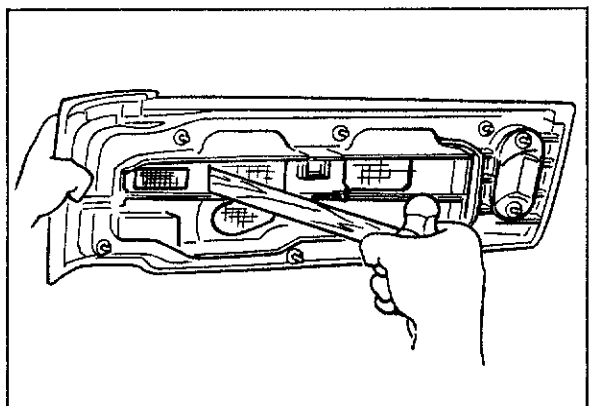

63U14X-019

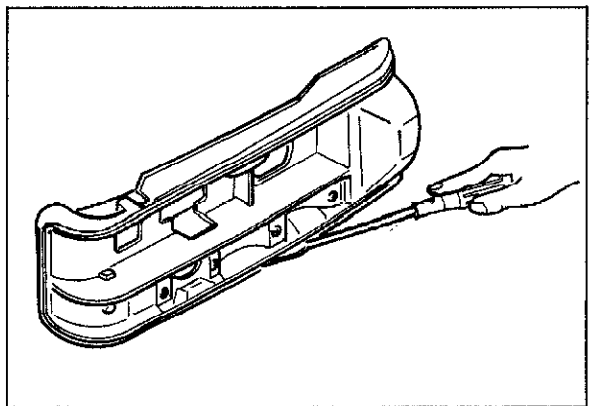

63U14X-020

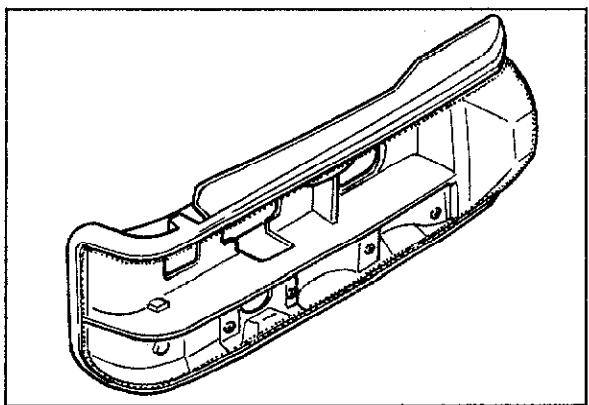

63U14X-021

## REPLACEMENT OF COMBINATION LIGHT LENS

1. Use a blow dryer to soften the "hot melt" (bonding agent) around the lens to be replaced.

2. Remove the lens from the light housing by pushing the rear of the lens with a hammer handle or round bar.

3. While heating the light housing, remove the "hot melt" and any remaining fragments of the lens.

### Note

The "hot melt" should be reused if possible.

4. If the hot melt is not being reused, put **Uni-sealer** (8531 77 739) in the light housing groove for adhesive, and press the light housing in gently.

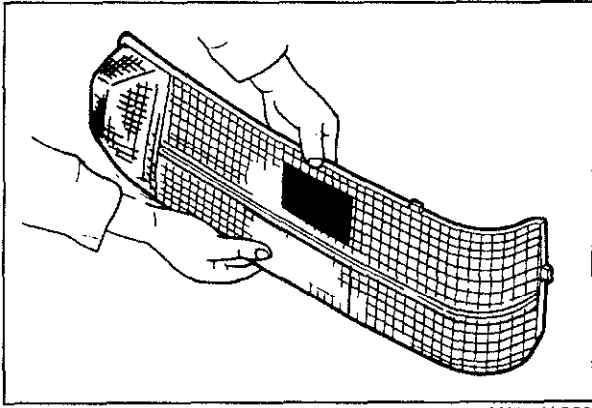

63U14X-022

5. Fit the new lens to the light housing, and press the lens firmly so that it will adhere.

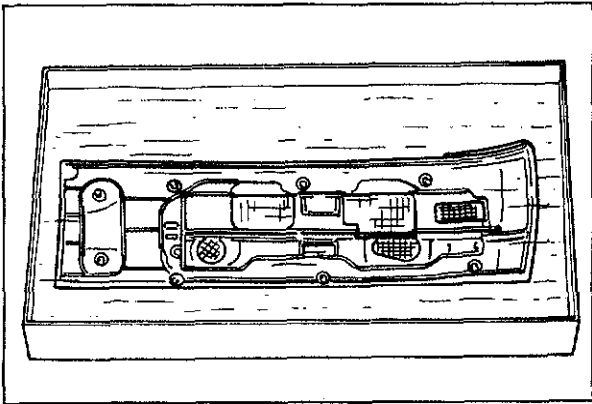

63U14X-023

6. Immerse the combination light in water to check for leaks.

# 14 HIGH MOUNTED STOP LIGHT

## HIGH MOUNTED STOP LIGHT

### REMOVAL AND INSTALLATION

1. Disconnect the battery negative cable.
2. Remove the parts in the sequence shown in the figure.
3. Install in the reverse order of removal.

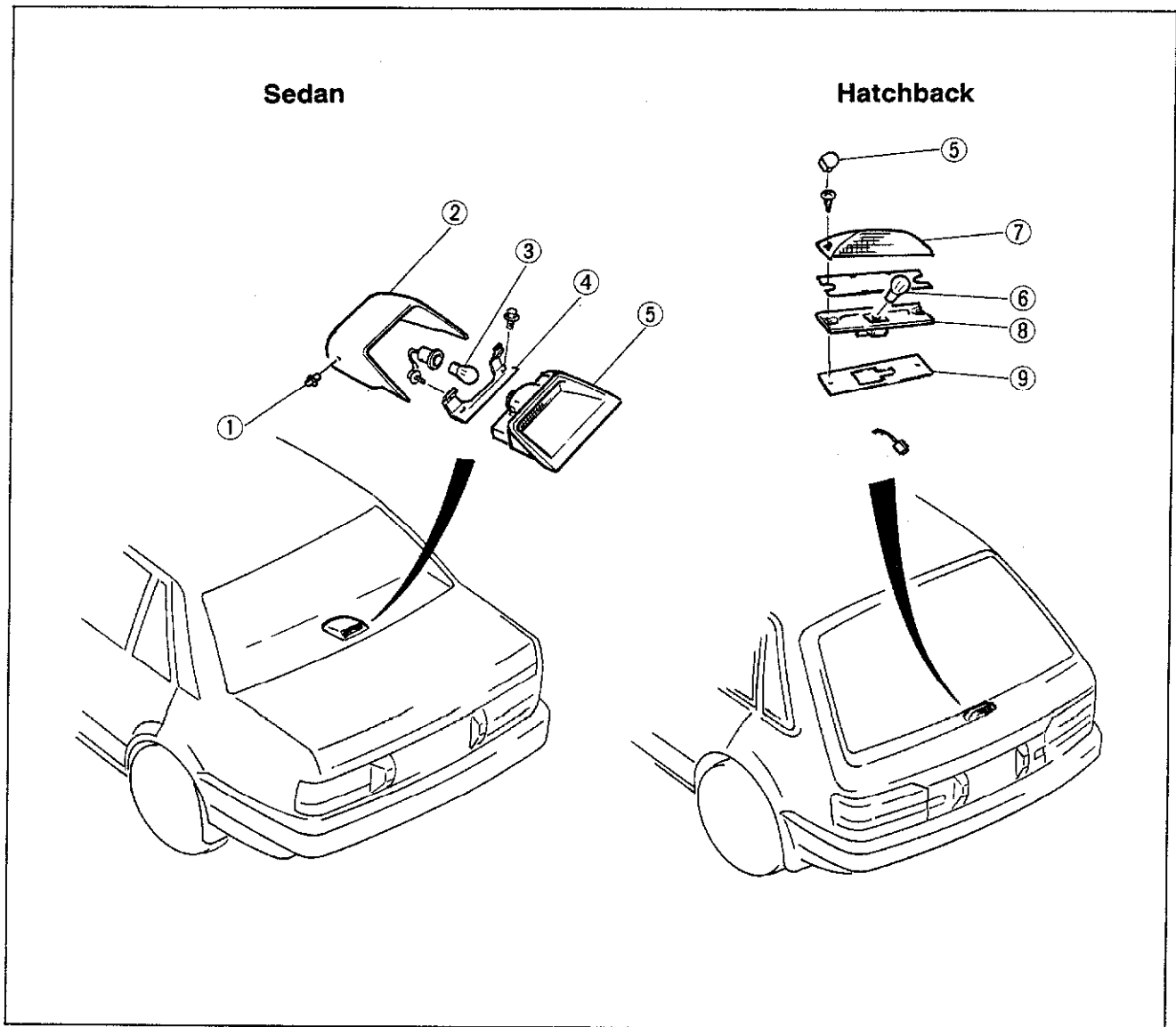

83U14X-008

1. Clip
2. Cover
3. Bulb (Sedan)

4. Bracket
5. Lens
6. Bulb (Hatchback)

7. Gasket
8. Housing
9. Protector

Light	Wattage (Bulb Trade Number)
High mounted stop light	18.4 (1141)



## LICENSE PLATE LIGHT

### REMOVAL AND INSTALLATION

1. Disconnect the battery negative cable.
2. Remove the parts in the sequence shown in the figure.
3. Install in the reverse order of removal.

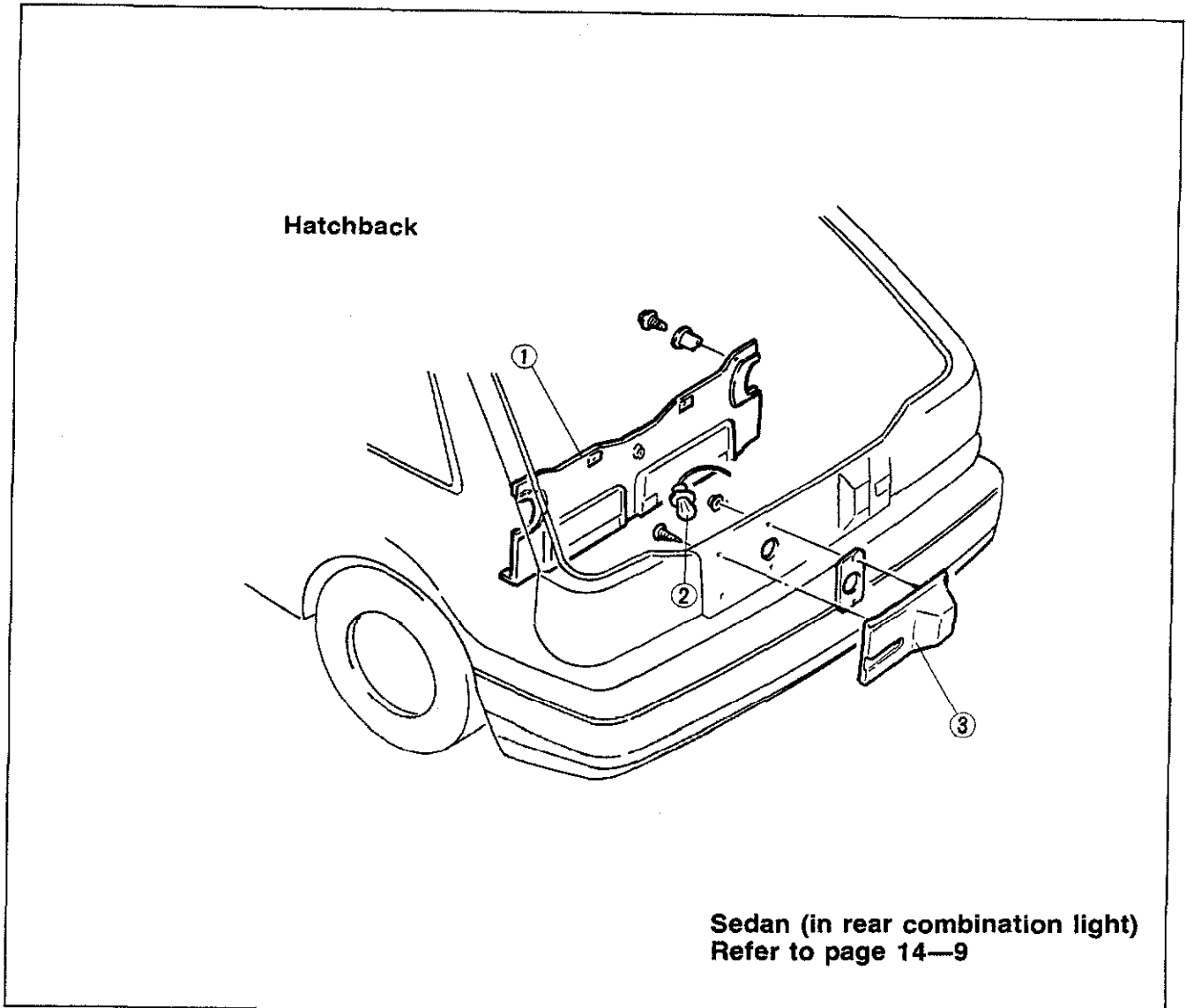

83U14X-009

1. Trim

2. Bulb

3. Housing

Light	Wattage (Bulb Trade Number)
License plate light	8 (67)

## INTERIOR LIGHT

### REMOVAL AND INSTALLATION

1. Disconnect the battery negative cable.
2. Remove the parts in the sequence shown in the figure.
3. Install in the reverse order of removal.

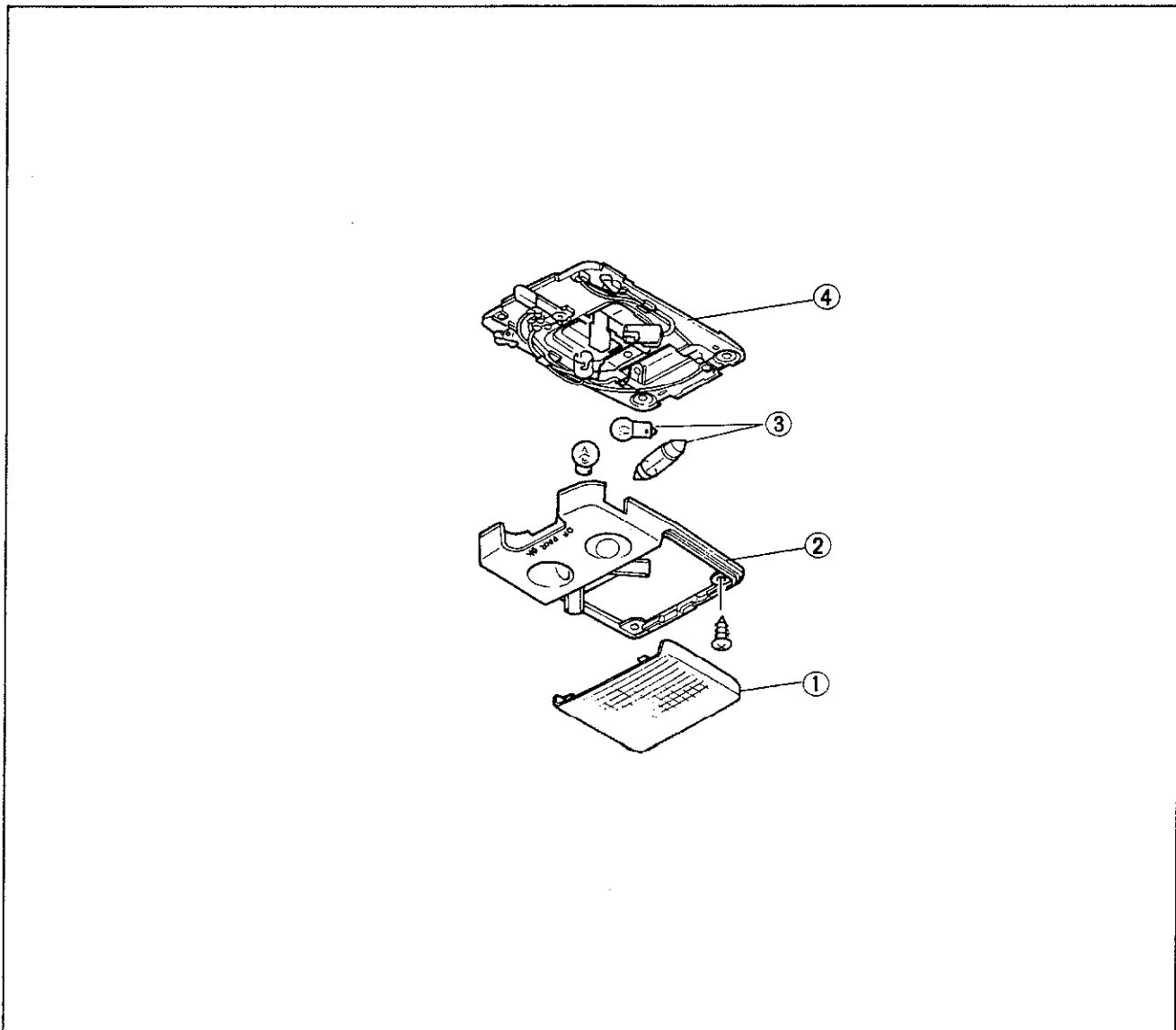

83U14X-010

- 1. Lens
- 2. Cover

- 3. Bulb
- 4. Body

Light	Wattage
Interior light	10
Map light	6

FRONT DOOR  
STRUCTURAL VIEW

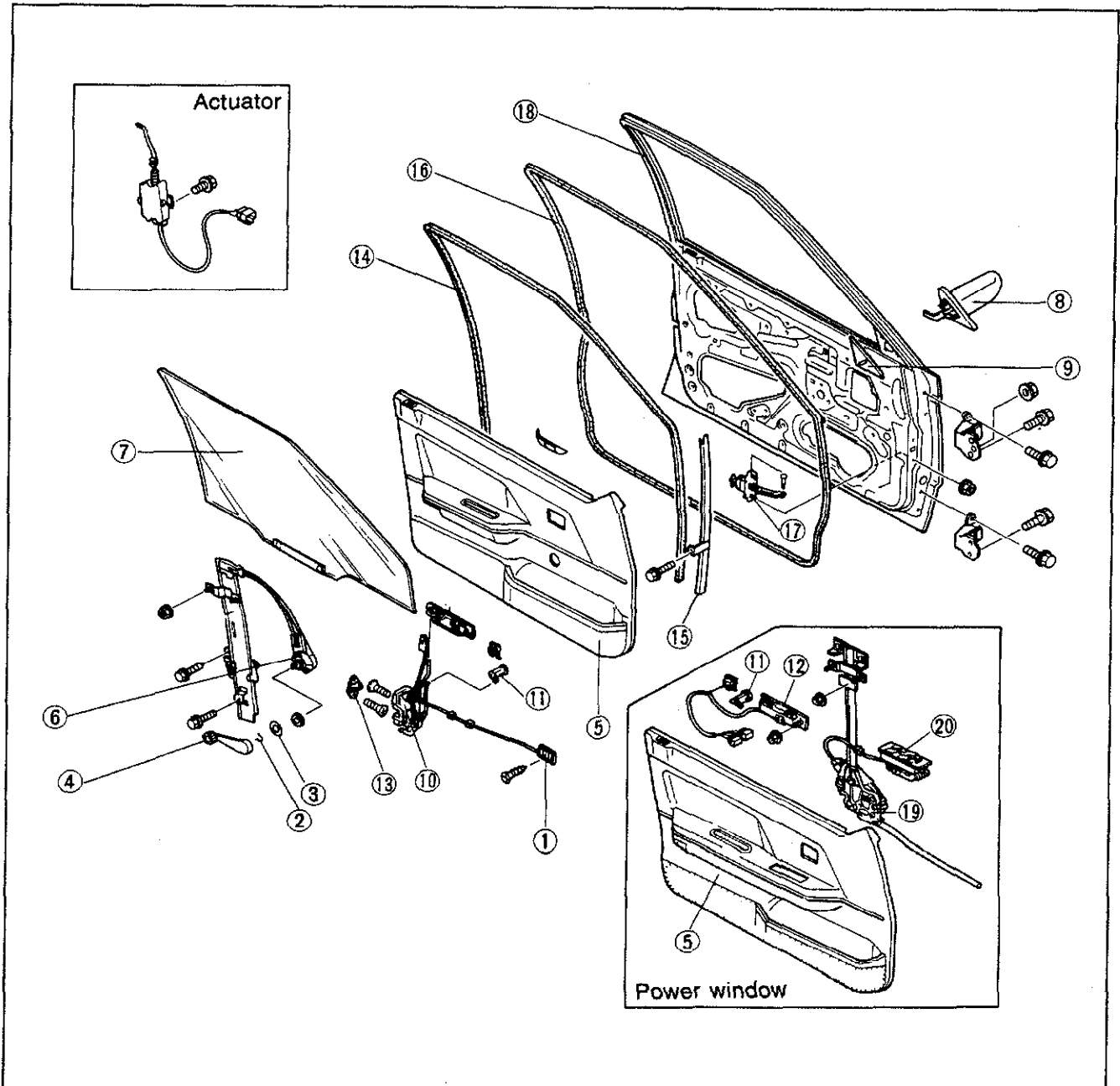

63U14X-027

- |                       |                       |                            |
|-----------------------|-----------------------|----------------------------|
| 1. Inner handle cover | 8. Mirror             | 15. Glass guide            |
| 2. Snap ring          | 9. Sail inner garnish | 16. Weatherstrip           |
| 3. Escutcheon         | 10. Door lock         | 17. Door checker           |
| 4. Regulator handle   | 11. Key cylinder      | 18. Door                   |
| 5. Door trim          | 12. Outer handle      | 19. Power window regulator |
| 6. Regulator          | 13. Striker           | 20. Power window switch    |
| 7. Glass              | 14. Glass channel     |                            |

# 14 FRONT DOOR, FRONT DOOR GLASS AND REGULATOR

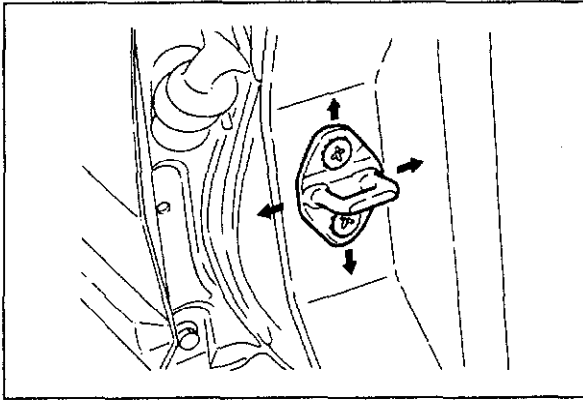

63U14X-028

## ADJUSTMENT

### Door Lock Striker

1. Check whether the door can be closed easily and whether there is any play. If there is a problem loosen the striker installation screws and adjust it by moving the striker up and down or side to side.
2. Check the rear offset of the door to the body. If there is a problem adjust it by moving the door lock striker side to side.

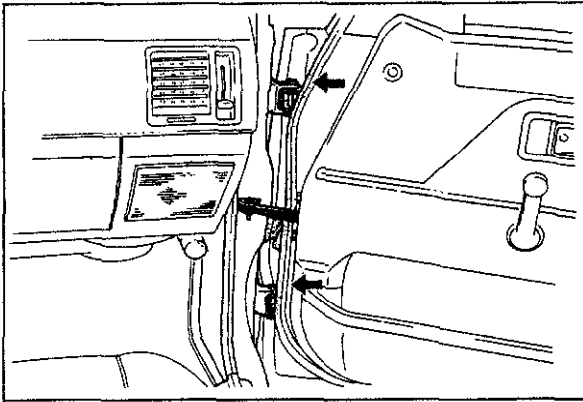

63U14X-029

### Door Hinges

1. Open the door. If there is play in the hinges, tighten the door hinge installation bolts (arrows).
2. To adjust the door-to-body offset, loosen the door hinge installation bolts and make the adjustment.

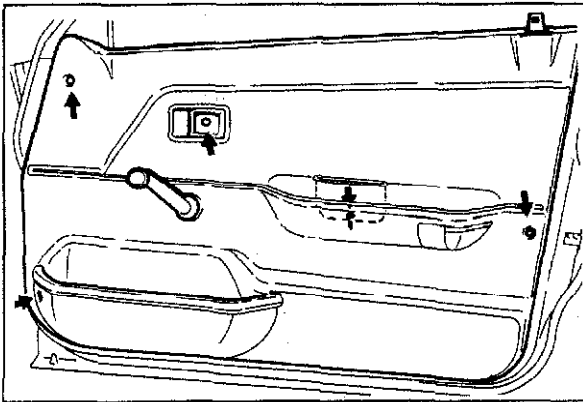

63U14X-030

## FRONT DOOR GLASS AND REGULATOR

### REMOVAL

1. Remove the inner handle cover, the regulator handle, and the door trim (arrows).

#### Note

**For vehicles with power windows, disconnect the power window connector.**

2. Peel off the door screen.

#### Caution

**Peel the screen off carefully so that it can be reused.**

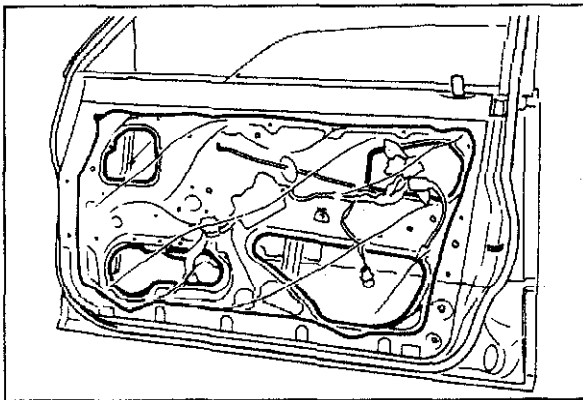

63U14X-031

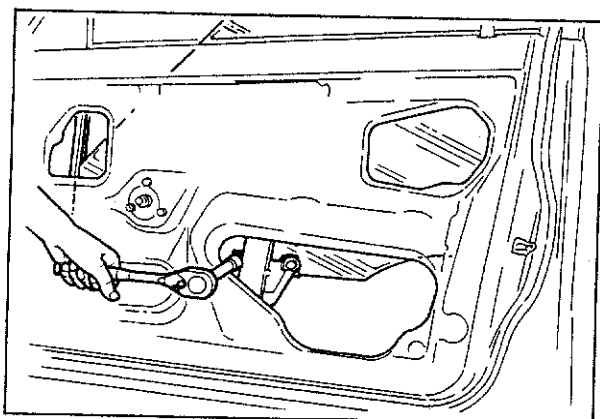

63U14X-032

3. Position the door glass so that the installation bolts can be removed from the service hole.
4. Remove the door glass installation bolts.

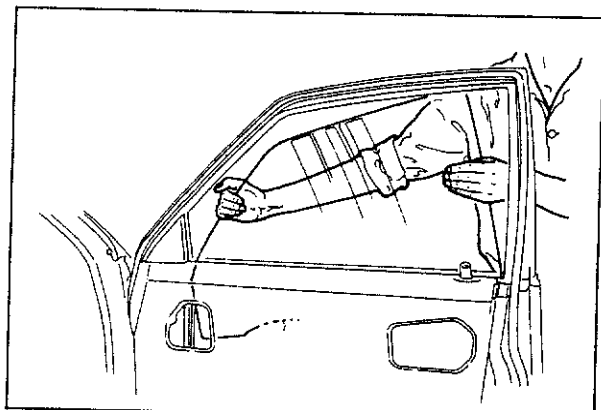

63U14X-033

5. Remove the door glass upward.

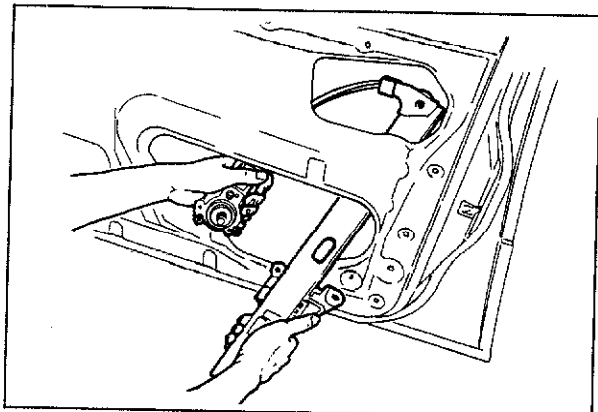

63U14X-034

6. Remove the regulator installation bolts, and then remove the regulator through the service hole.
7. Remove the window motor mounting bolts, then remove the motor from the regulator (power window).

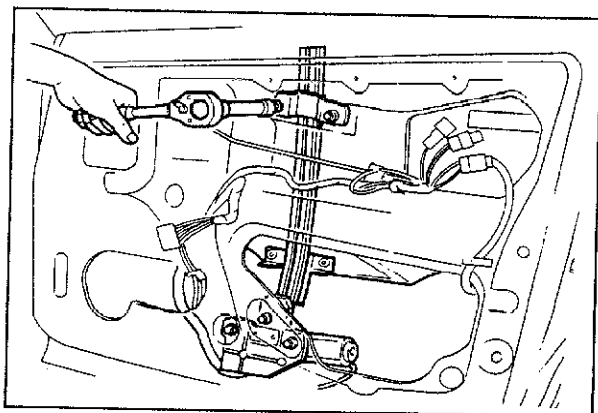

63U14X-035

## INSTALLATION

Install in the reverse order of removal, noting the following:

### Power Window

Before installing the motor, connect the leads to a battery and run the regulator down to the position shown.

## REAR DOOR

### STRUCTURAL VIEW

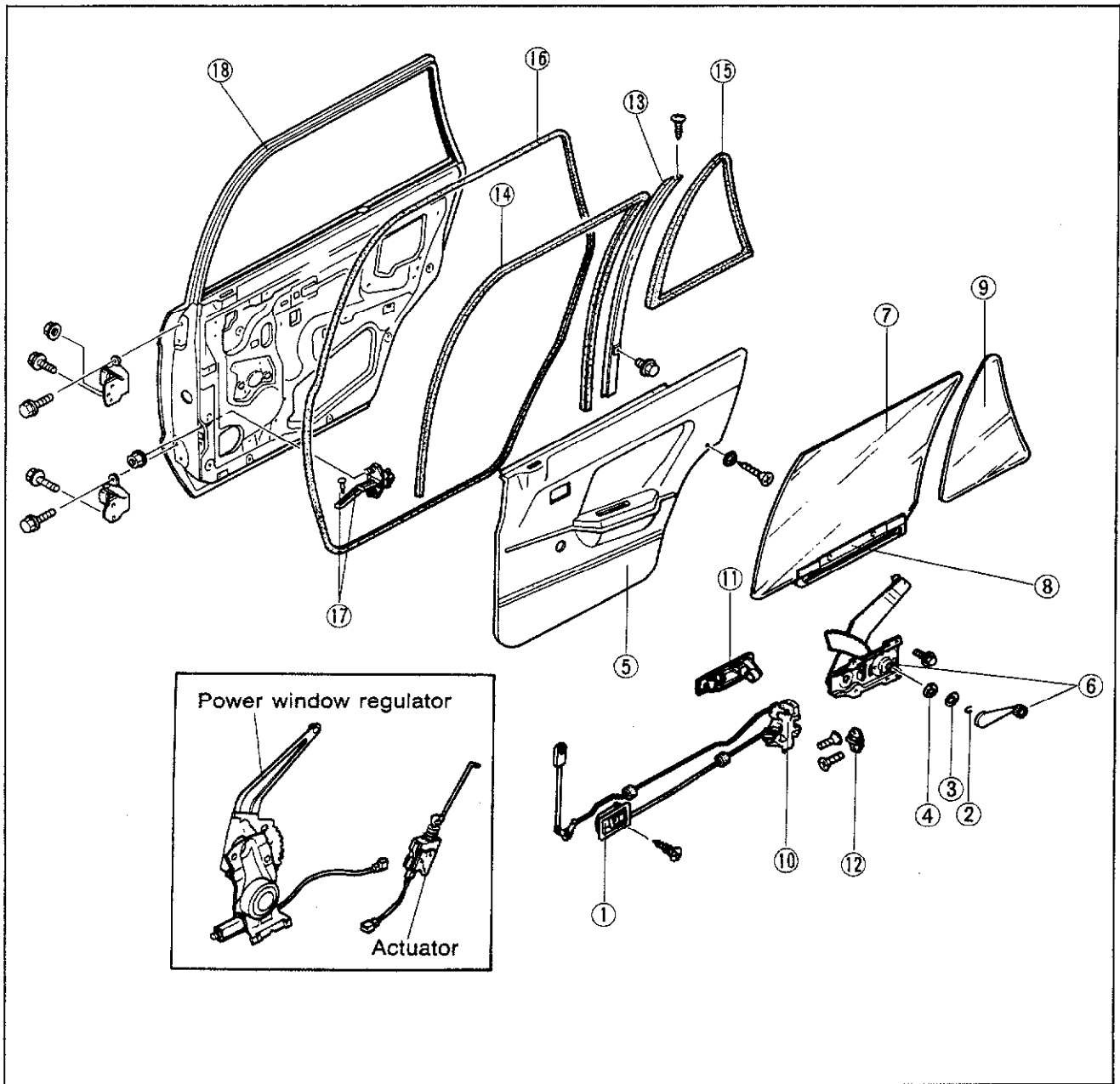

63U14X-036

- |                                   |                         |                                   |
|-----------------------------------|-------------------------|-----------------------------------|
| 1. Inner handle cover             | 7. Glass                | 14. Glass channel                 |
| 2. Snap ring                      | 8. Lift bracket         | 15. Weatherstrip (quarter window) |
| 3. Escutcheon                     | 9. Quarter window glass | 16. Weatherstrip                  |
| 4. Regulator handle bezel         | 10. Door lock           | 17. Door checker                  |
| 5. Door trim                      | 11. Outer handle        | 18. Door                          |
| 6. Regulator and regulator handle | 12. Striker             |                                   |
|                                   | 13. Center channel      |                                   |

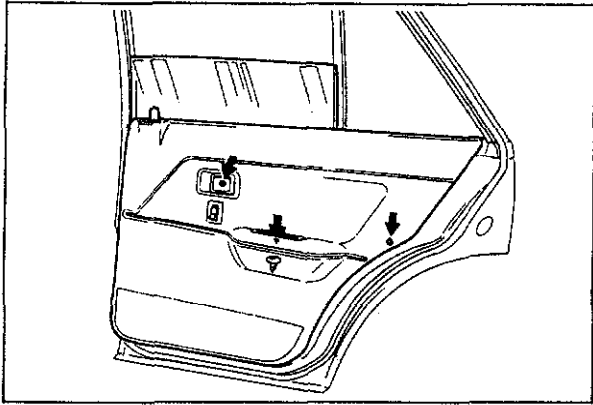

63U14X-037

## REAR DOOR GLASS AND REGULATOR, QUARTER WINDOW GLASS

### REMOVAL

1. Lower the door glass all the way.
2. Remove the inner handle cover and the regulator handle.
3. Remove the door trim.

### Note

For vehicles with power windows, disconnect the power window connector.

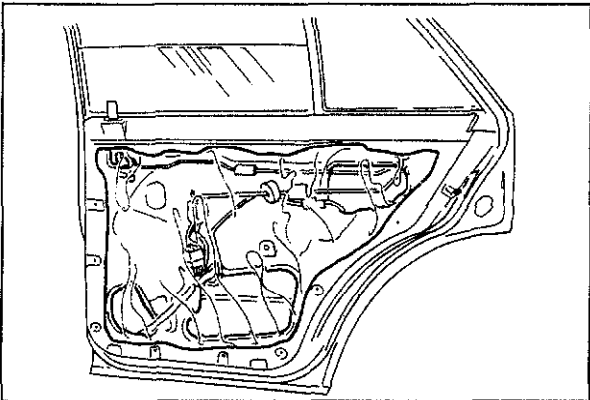

63U14X-038

4. Remove the door screen.

### Caution

Remove the screen carefully so that it can be reused.

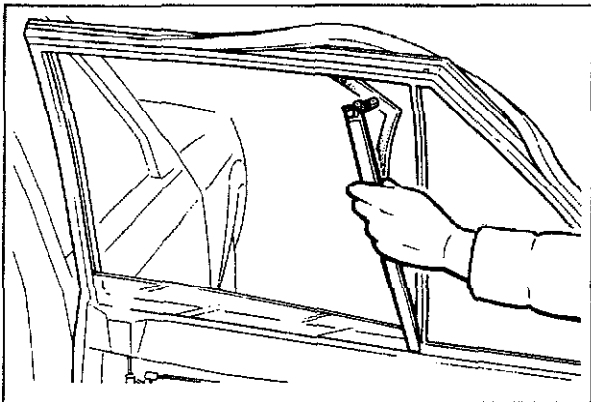

63U14X-039

5. Remove the screw and bolt, and remove the center channel.
6. Remove the quarter window glass.

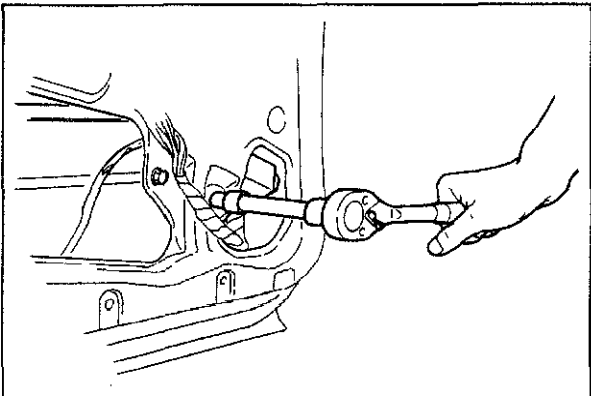

63U14X-040

7. Roll the door glass down and remove the lift bracket from the roller. Remove the door glass up and out.

# 14 REAR DOOR GLASS AND REGULATOR, QUARTER WINDOW GLASS

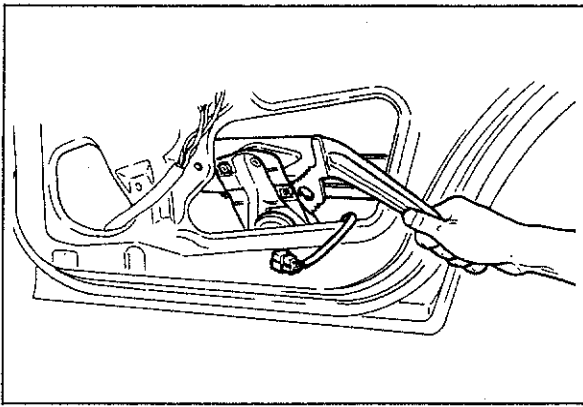

63U14X-041

8. Remove the window regulator installation bolts, and remove the regulator through the service hole.
9. Remove the window motor mounting bolts, then remove the motor from regulator (power window).

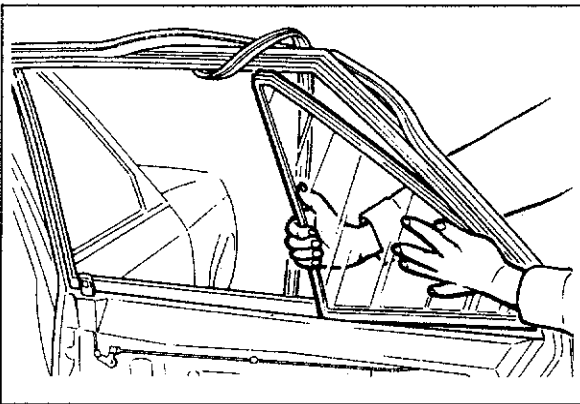

63U14X-042

## INSTALLATION

Install in the reverse order of removal, noting the following:

1. Apply soapy water to the outer circumference of the weatherstrip when installing the quarter window.
2. Before installing the motor, connect the leads to a battery and run regulator down to the position shown (power window).

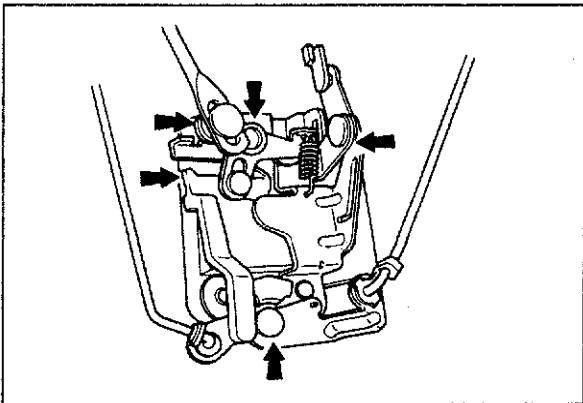

63U14X-043

## INSTALLATION OF DOOR LOCK AND OUTER HANDLE

Note the following for installation, which is in the reverse order of removal.

1. Before installing the door lock, apply grease to the places shown in the figure.
2. After installation, check that the door opens smoothly, and that the operation of the lock is correct when using the key and the door lock knob.



## BACK DOOR

### REMOVAL AND INSTALLATION

1. Remove the parts in the sequence shown in the figure.
2. Install in the reverse order of removal.

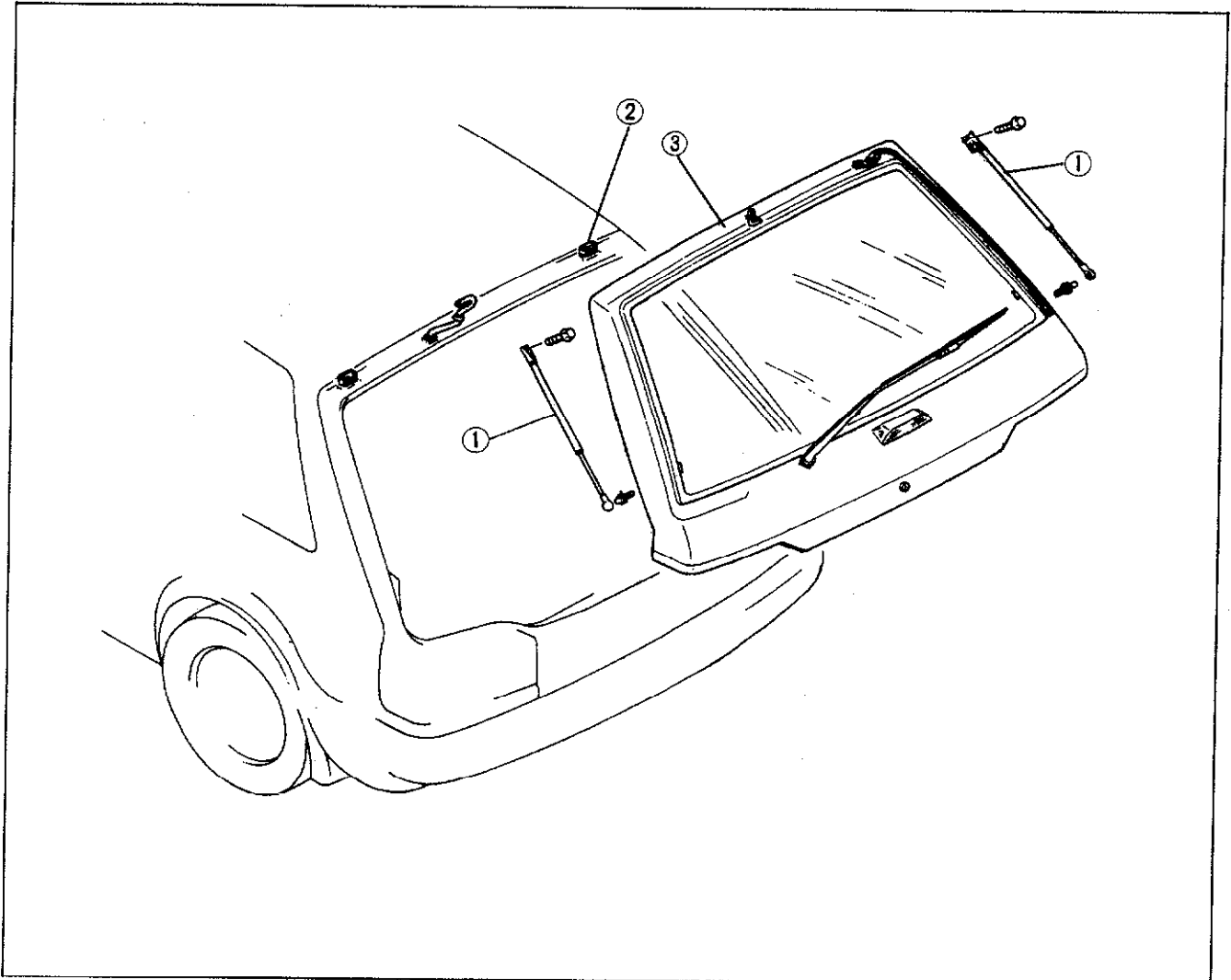

63U14X-044

1. Stay damper

2. Back door hinge

3. Back door

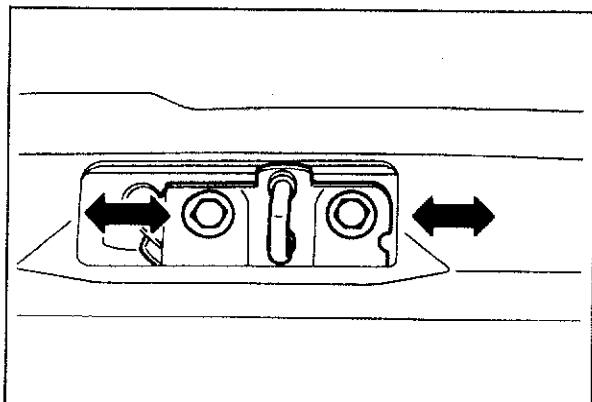

63U14X-045

### Adjustment of Striker and Hinge.

Adjust the striker hinge with the mounting bolts.

# 14 FRONT WINDOW GLASS

## FRONT WINDOW GLASS

### STRUCTURAL VIEW

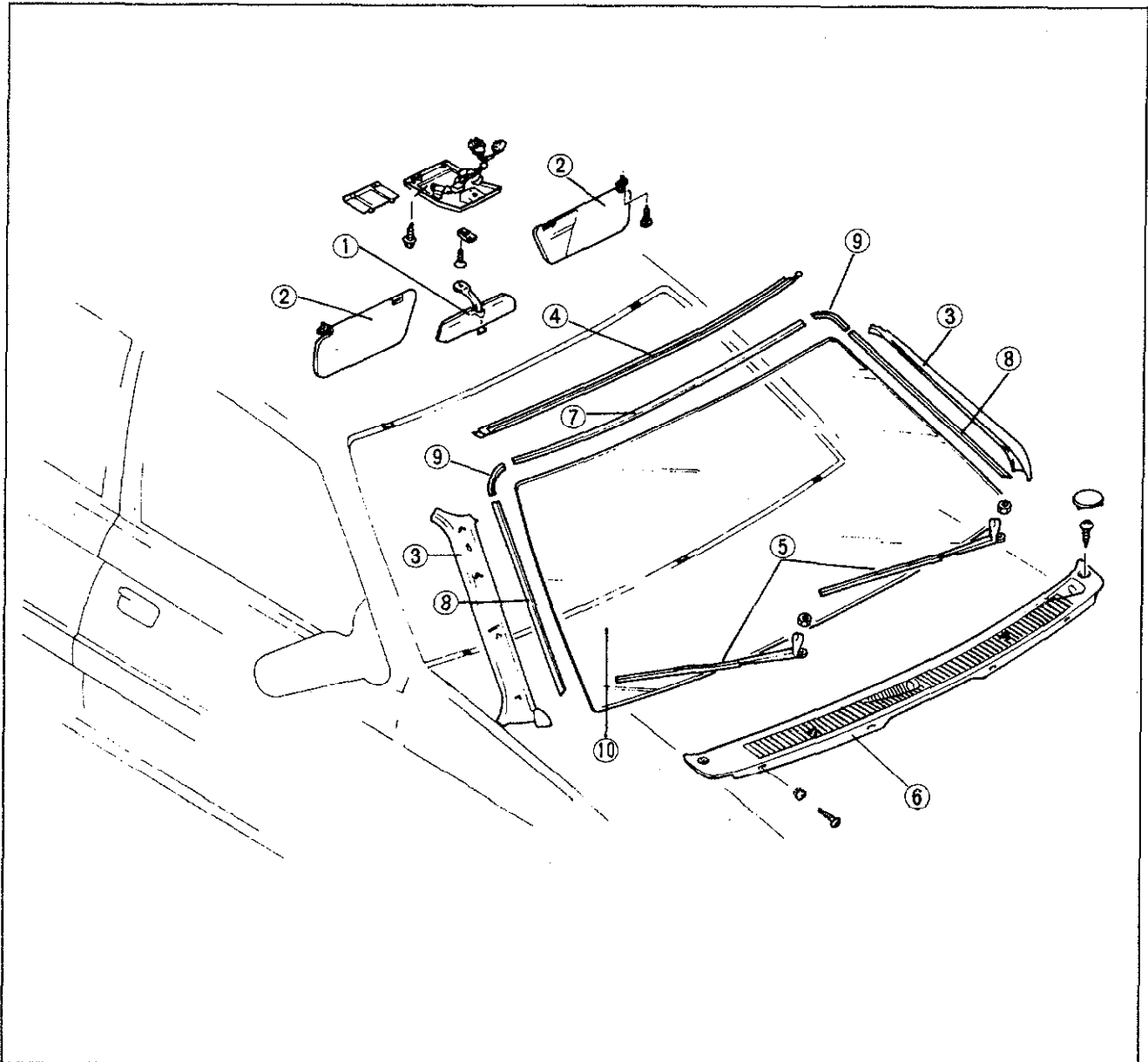

63U14X-046

- 1. Interior mirror
- 2. Sun visor
- 3. Front pillar garnish
- 4. Front header trim

- 5. Wiper arm
- 6. Cowl grille
- 7. Front upper molding
- 8. Front side molding

- 9. Molding joint
- 10. Glass

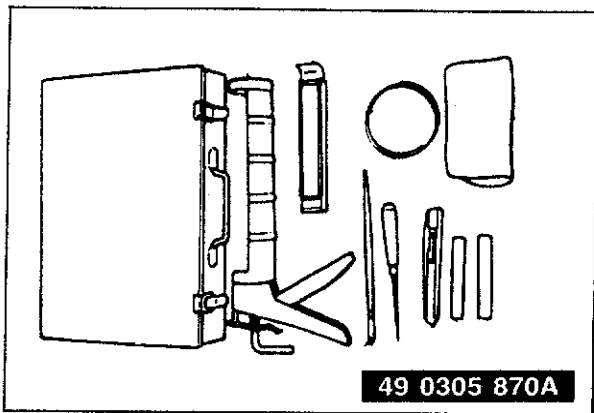

83U14X-019

## REMOVAL

Use **SST** to remove and install the glass.

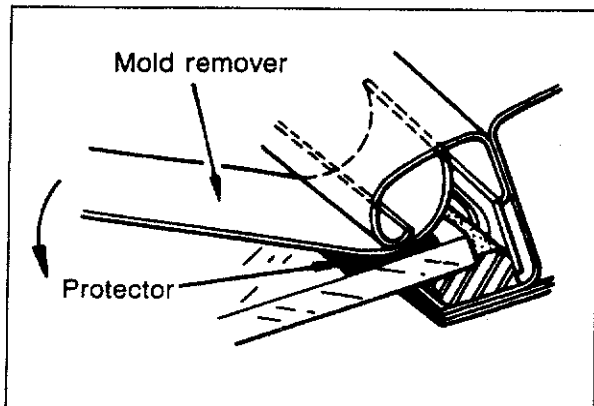

63U14X-048

1. Remove the interior mirror, sunvisors, front pillar trim, and front header trim.
2. Remove the wiper arms and cowl grill.
3. Remove the front window molding.

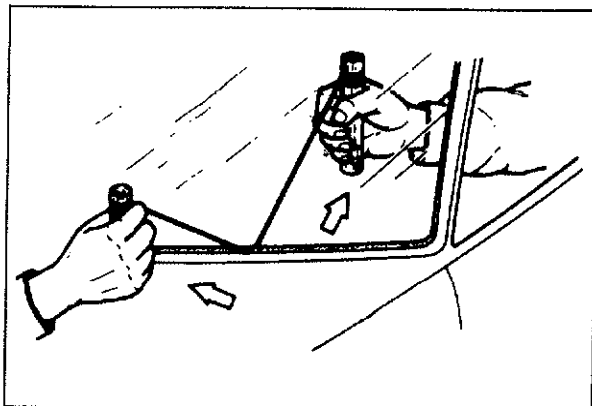

63U14X-049

4. Remove the glass by separating the glass from the sealant using a commercial power or manually operated remover tool, or use the following procedure.

Use an awl to make a hole in the sealant.

Pass the end of a piece of the piano wire (about 40 cm, 15.7 in) through the hole, and attach bars to both ends.

5. Two people should hold the bars, one inside and one outside the vehicle, and then "saw" the sealant from around the glass.
6. Remove the glass from the body.

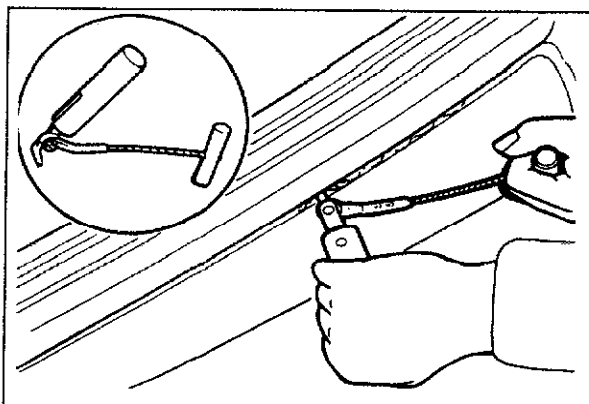

63U14X-050

## Caution

- a) Cut along the border between the glass and the sealant.
- b) If too much heat develops, the piano wire may break, so cool it occasionally or don't work on one place too long.
- c) If the glass is not to be reused, a tool like that shown in the figure is faster than piano wire.

# 14 FRONT WINDOW GLASS

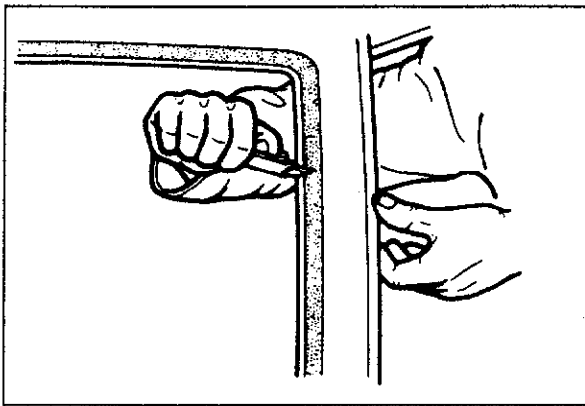

63U14X-051

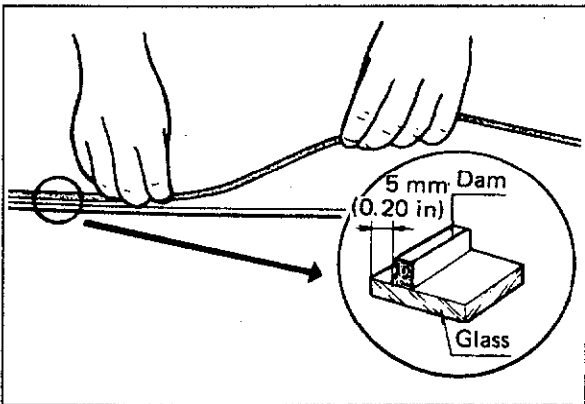

63U14X-052

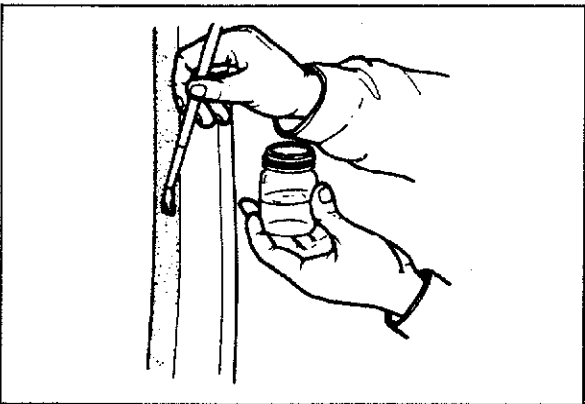

83U14X-020

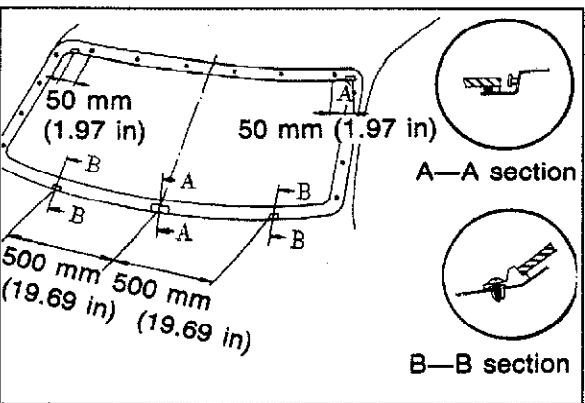

63U14X-054

## INSTALLATION

1. Use a knife to smoothly trim the sealant on the body. Leave a layer about **1 or 2 mm (0.04 to 0.08 in)** thick.

### Caution

**If some sealant flakes off, use new sealant to patch it.**

2. Carefully clean and remove any grease from a **5 cm (1.97 in)** wide area around the circumference of the glass and the remaining bond on the body.
3. Bond a dam along the circumference of the glass **5 mm (0.20 in)** from the edge.

### Caution

**Securely bond the dam and let it dry.**

4. Apply primer with a brush to the circumferences of the glass and the body, and allow it to naturally dry for 20 to 30 minutes.

### Caution

**Be sure not to allow dirt, water, oil etc. to come in contact with the coated surfaces and do not touch it with your hand.**

5. Install the spacers at the positions shown in the figure.

### Caution

**Clips with flaws must be replaced.**

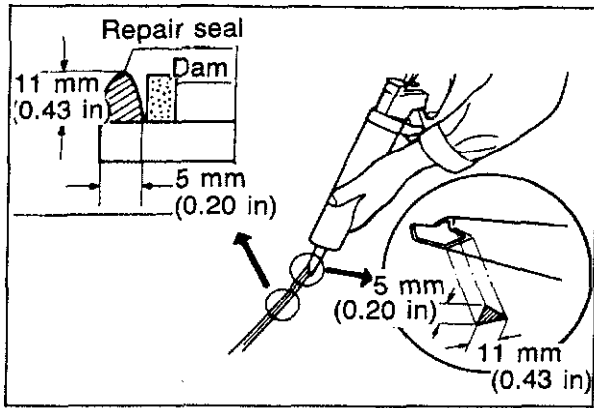

83U14X-021

- When the primer has dried, apply an **11 mm (0.43 in)** thick bead of **repair seal (B001 77 739)** 5 mm (0.20 in) from the periphery of the glass using a sealant gun.

**Caution**

- Cut the nozzle of the repair seal cartridge as illustrated in the figure.
- If necessary, smooth the repair seal to correct any irregularities.

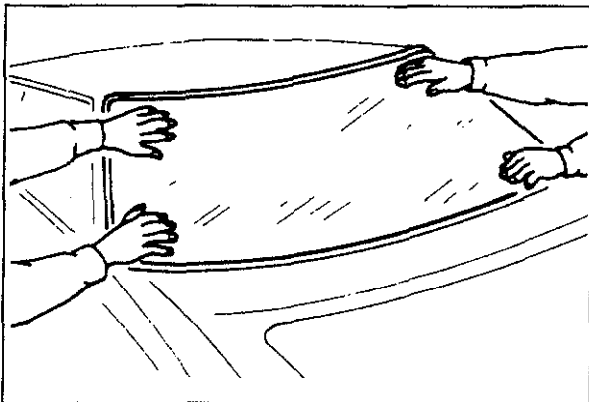

63U14X-056

- Attach the front glass to the body.

**Caution**

Keep the door glass open until the repair seal hardens to some degree to prevent pressure from being exerted on the front glass. If the door is closed quickly.

**Hardening time of repair seal**

Temperature	Surface hardening time	Time required until vehicle can be put in service
5°C (41°F)	Approx. 1.5 hrs	12 hrs
20°C (68°F)	Approx. 1 hr	4 hrs
35°C (95°F)	Approx. 10 min.	2 hrs

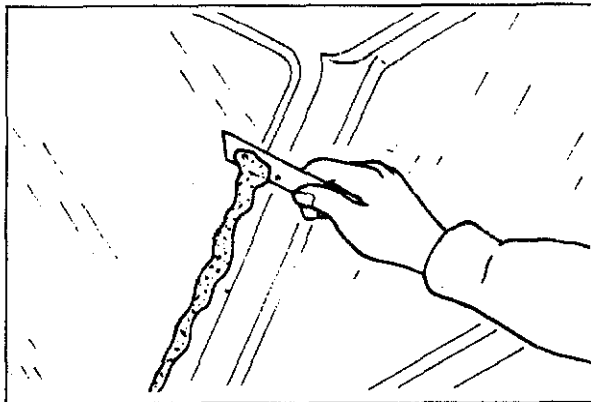

63U14X-057

- Remove any excess, or add repair seal where necessary.

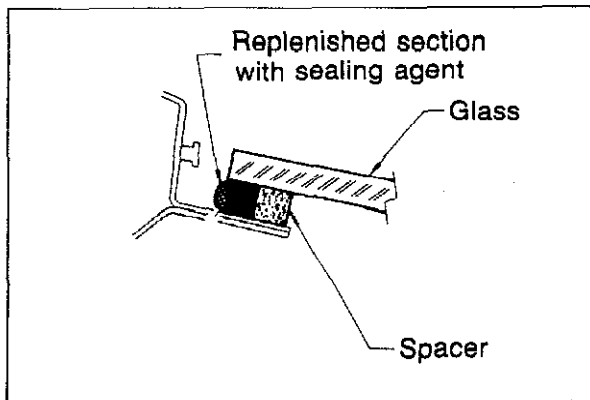

63U14X-058

- Check for water leaks. If a leak is found, wipe the water off well and add **repair seal (B 001 77 739)**.
- After checking for water leakage, mount the pillar garnish, cowl panel, cowl grill, wiper, etc.
- Attach the front header trim, pillar trim, sun visors, interior mirror, etc.

# 14 BACK DOOR GLASS (HATCHBACK)

## BACK DOOR GLASS (HATCHBACK)

### STRUCTURAL VIEW

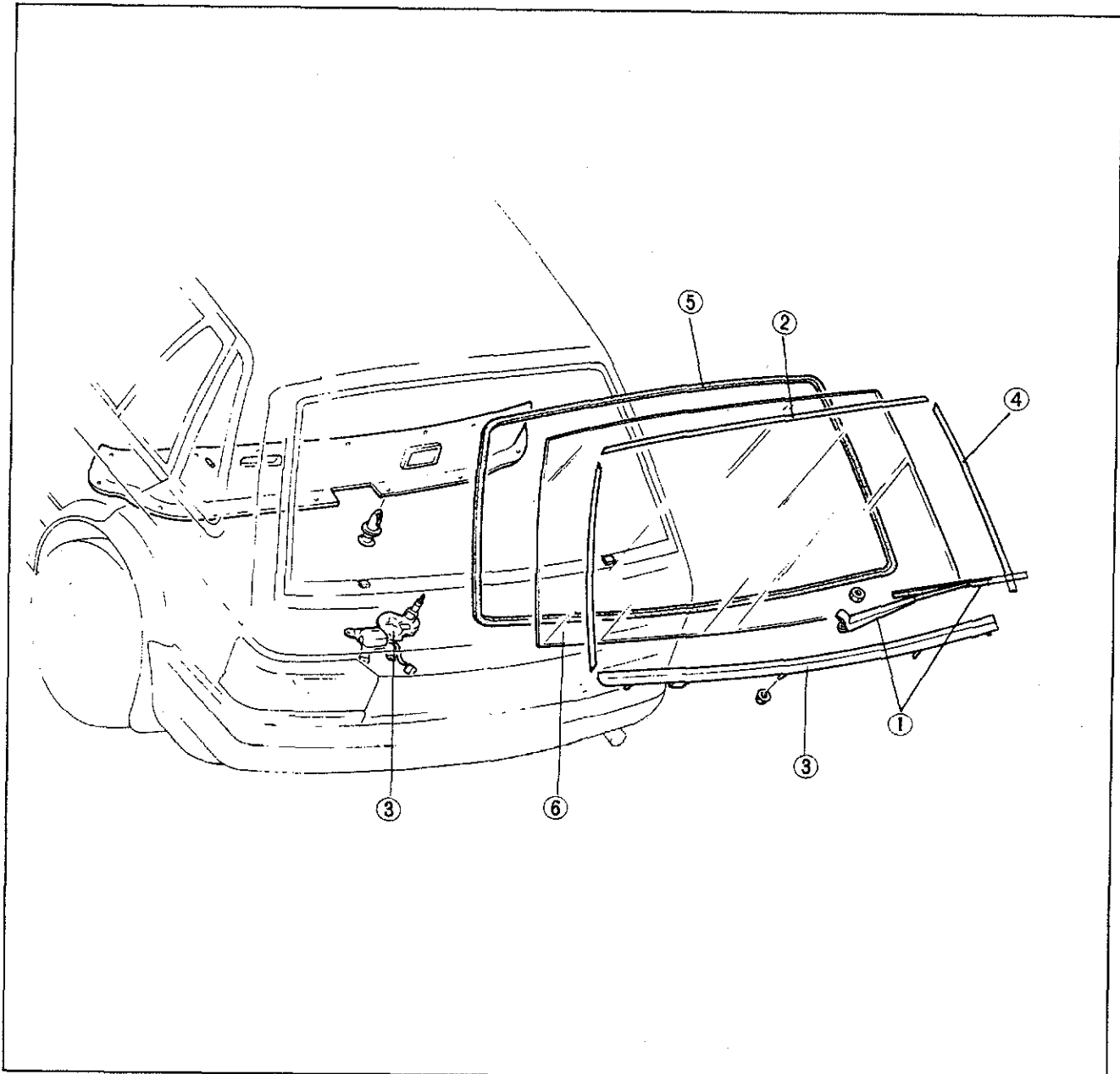

63U14X-059

1. Wiper arm  
2. Rear upper molding

3. Rear lower molding  
4. Rear side molding

5. Weatherstrip  
6. Glass

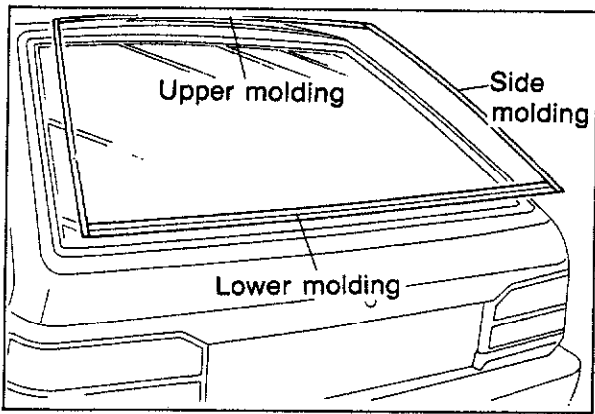

83U14X-021

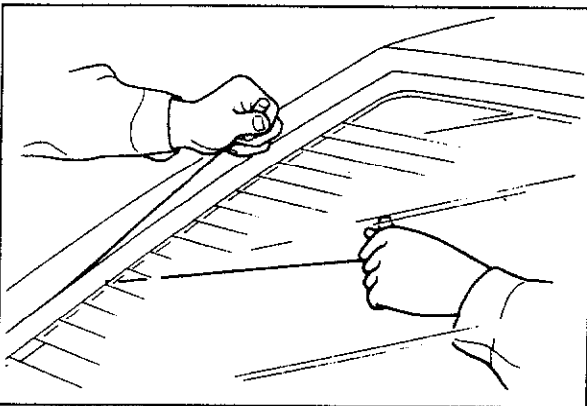

63U14X-061

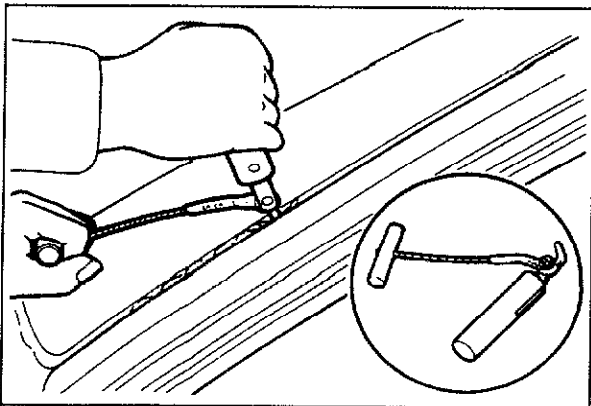

63U14X-062

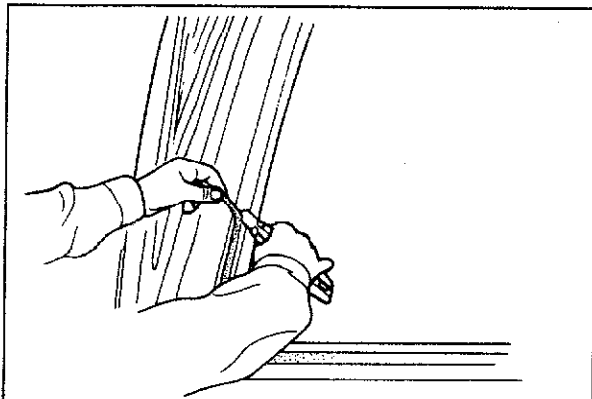

63U14X-063

## REMOVAL

Use the **SST** to remove and install the glass.

1. Remove the wiper arm, wiper motor, back door trim and defogger connector.
2. Remove the rear window molding.

3. Use an awl to make a hole in the sealant. Pass the end of a piece of the piano wire (about 40 cm 15.7 in) through the hole, and attach bars to both ends.
4. Two people should hold the bars, one inside and one outside the vehicle, and then "saw" the sealant from around the glass.
5. Remove the glass from the body.

## Caution

- a) Cut along the border between the glass and the sealant.
- b) If too much heat develops, the piano wire may break, so cool it occasionally or don't work on one place too long.
- c) If the glass is not to be reused, a tool like that shown in the figure is faster than piano wire.

## INSTALLATION

1. Use a knife to smoothly trim the sealant on the body. Leave a layer about 1 or 2 mm (0.04 to 0.08 in) thick.

## Caution

If some sealant flakes off, use new sealant to patch it.

# 14 BACK DOOR GLASS

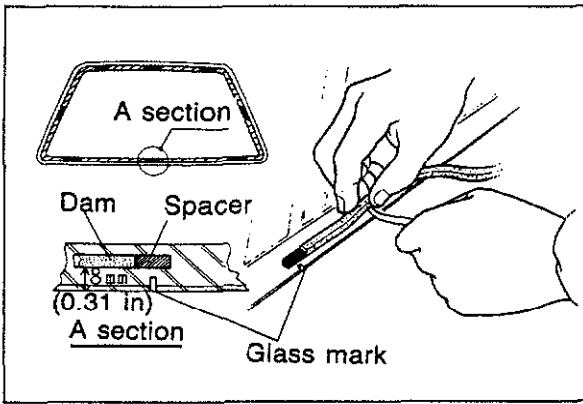

63U14X-064

- Carefully clean and remove any grease from a **5 cm (1.97 in)** wide area around the circumference of the glass and the remaining bond on the body.
- Bond a dam along the circumference of the glass **8 mm (0.31 in)** from the edge.

**Caution**  
Securely bond the dam and let it dry.

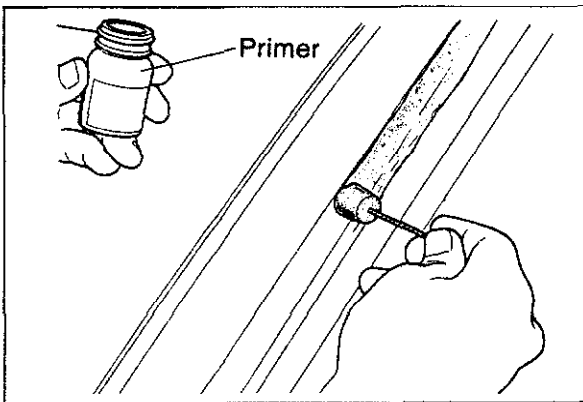

63U14X-065

- Apply primer with a brush to the circumference of the glass and the body and let them naturally dry for 20 to 30 minutes.

**Caution**  
Be sure not to allow dirt, water, oil, etc. to come in contact with the coated surfaces and do not touch it with your hand.

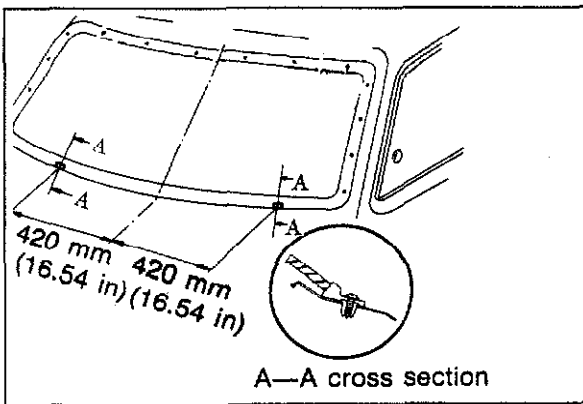

63U14X-066

- Install the spacers at the positions shown in the figure.

**Caution**  
Clips, with flaws, must be replaced.

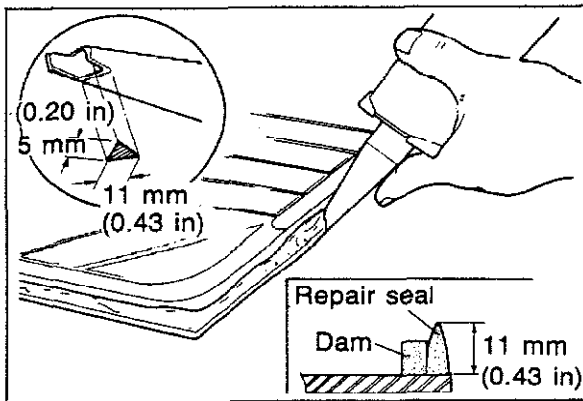

83U14X-022

- When the primer has dried, apply an 11 mm (0.43 in) thick bead of **repair seal** (B001 77 739) **5 mm (0.20 in)** from the periphery of the window glass using a sealant gun.

**Caution**  
Cut the nozzle of the repair seal cartridge as illustrated in the figure.  
If necessary, smooth the repair seal to correct any irregularities.



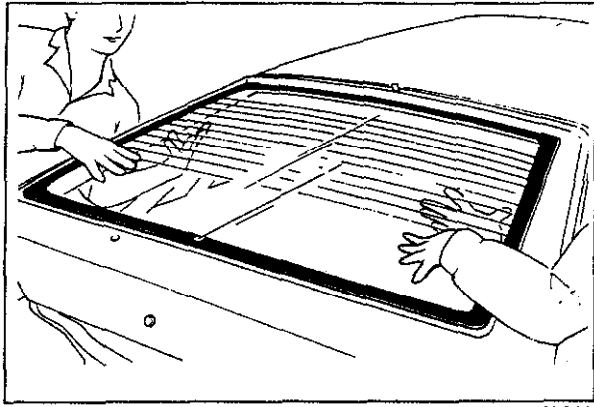

83U14X-023

7. Attach the back door glass to the body.

**Caution**

**Keep the door glass open until the repair seal hardens to some degree to prevent pressure from being exerted on the back door glass. If the door is closed quickly etc.**

**Hardening time of repair seal**

Temperature	Surface hardening time	Time required until vehicle can be put in service
5°C (41°F)	Approx. 1.5 hrs	12 hrs
20°C (68°F)	Approx. 1 hr	4 hrs
35°C (95°F)	Approx. 10 min.	2 hrs

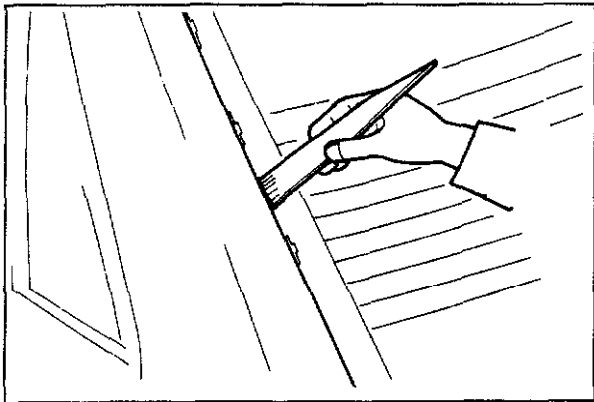

63U14X-069

8. Remove any excess or add repair seal where necessary.

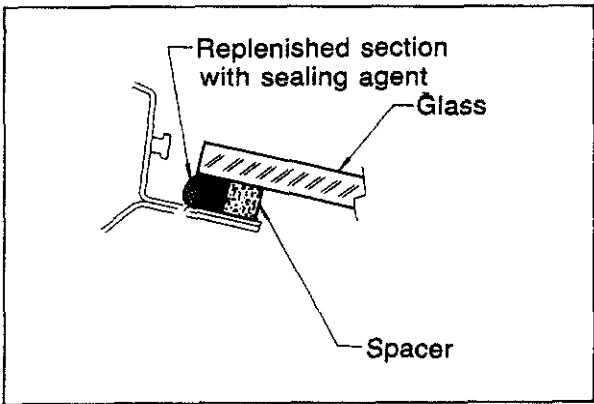

63U14X-070

9. Check for water leaks. If a leak is found, wipe the water off well and add **repair seal** (B001 77 739).

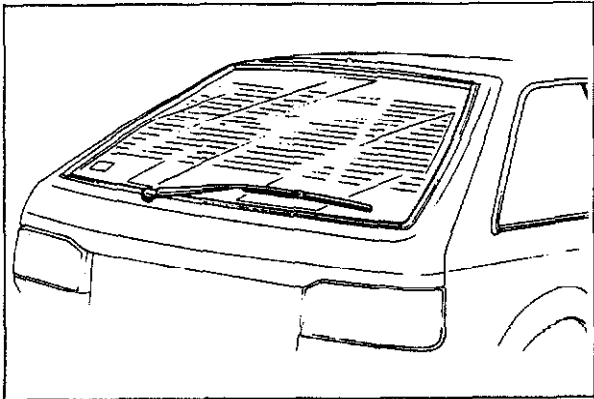

63U14X-071

10. After checking for water leakage, install the mold.

11. Install the wiper arm, wiper motor door trim and defogger connector.

# 14 REAR WINDOW GLASS

## REAR WINDOW GLASS

### STRUCTURAL VIEW

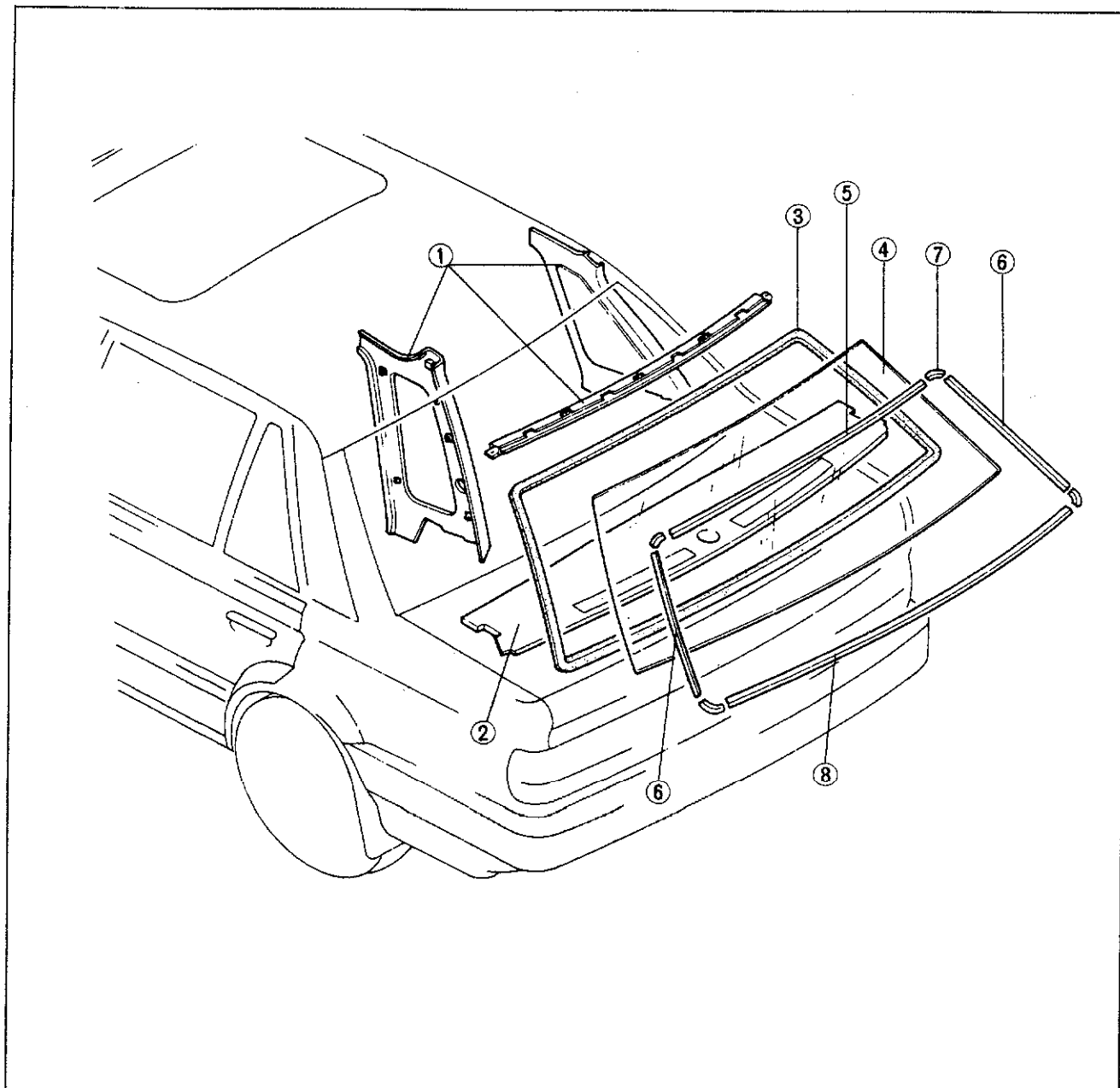

83U14X-011

1. Pillar trim  
2. Package tray trim  
3. Weatherstrip

4. Glass  
5. Upper molding  
6. Side molding

7. Molding joints  
8. Lower molding

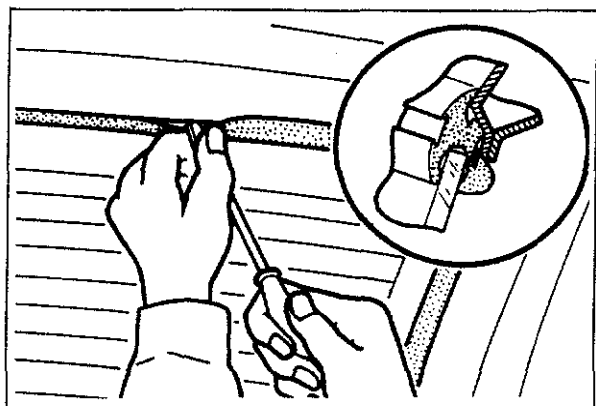

83U14X-024

## REMOVAL

Use **SST** to remove and install the glass.

1. Disconnect the defroster connector, remove the pillar trim, wiper motor and package tray trim.
2. From inside the vehicle, lift the weatherstrip toward the interior, and remove the glass with the weatherstrip attached.
3. Remove the molding.

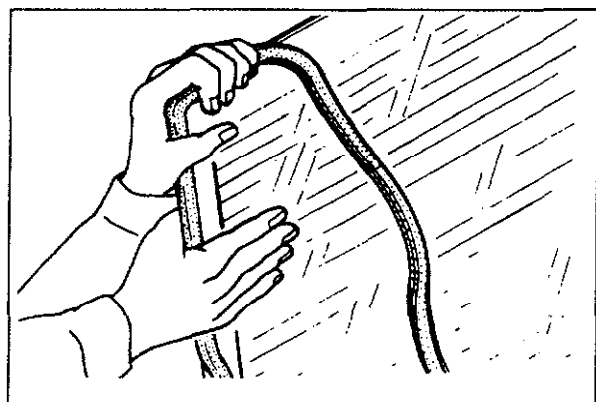

63U14X-074

## INSTALLATION

1. Remove any filler remaining on the body surface.
2. Attach the weatherstrip to the glass.

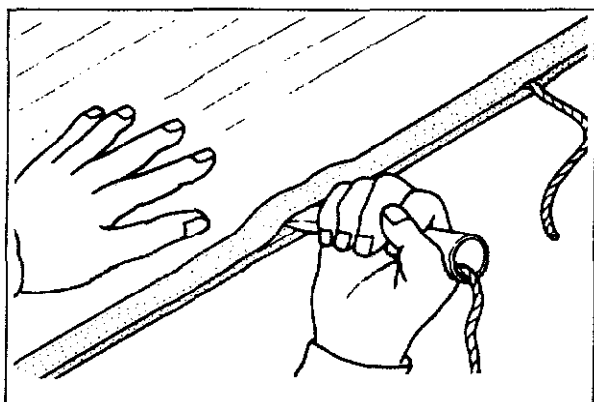

63U14X-075

3. Fit string into the weatherstrip on the interior side of the glass, and overlap it about **50 mm (2.0 in)** at the bottom center.
4. Coat the weatherstrip with soapy water so that the weatherstrip will slide easily into the window frame.
5. Align the glass and weatherstrip to the body.

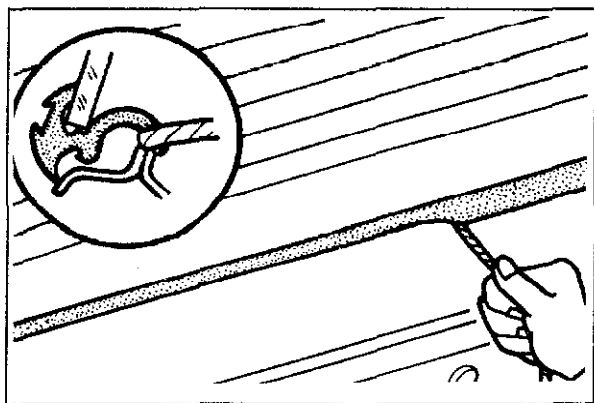

83U14X-012

6. While gently tapping around the weatherstrip at the outer side of the glass, pull one end of the string and fit the glass to the body.
7. Tap the glass from inside and outside with the palm of your hand. Strike the same place inside and out simultaneously, in order to seat the glass.
8. Install the molding (Refer to page 14—39).

# 14 REAR WINDOW GLASS

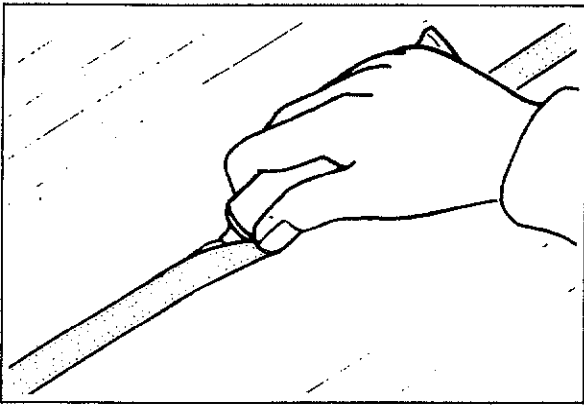

63U14X-077

9. Put filler (**TP-33M**) or equivalent sealant between the body and glass and the weatherstrip.

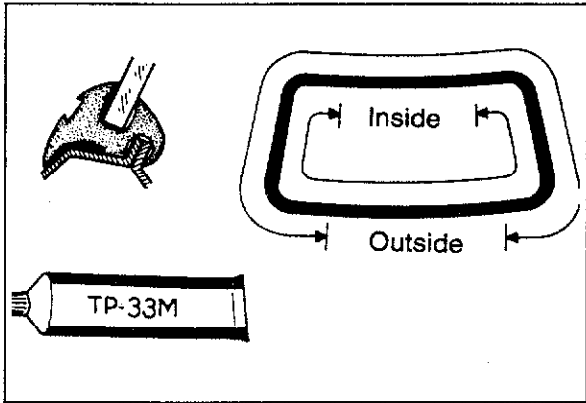

63U14X-078

10. Install the filler as shown in the figure.

**Note**

**Mask the body with tape so that excess filler can be easily removed.**

**QUARTER WINDOW GLASS (3 DOOR HATCHBACK)**

**REMOVAL AND INSTALLATION**

1. Remove the parts in the sequence shown in the figure.
2. Install in the reverse order of removal.

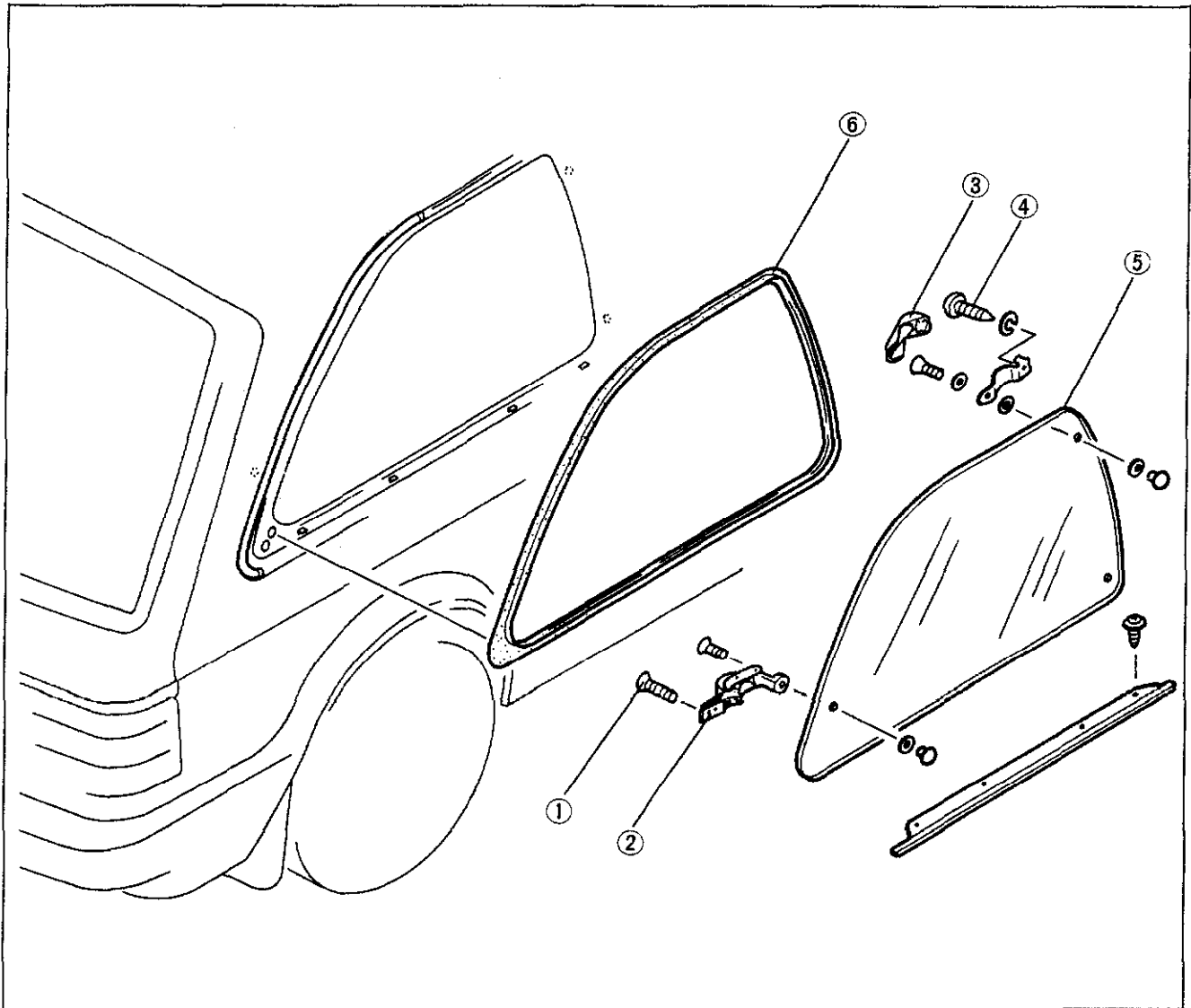

63U14X-079

1. Screw
2. Lock

3. Hinge cover
4. Screw

5. Glass
6. Weatherstrip

## QUARTER WINDOW GLASS (5 DOOR HATCHBACK)

### REMOVAL AND INSTALLATION

1. Remove the parts in the sequence shown in the figure.
2. Install in the reverse order of removal.

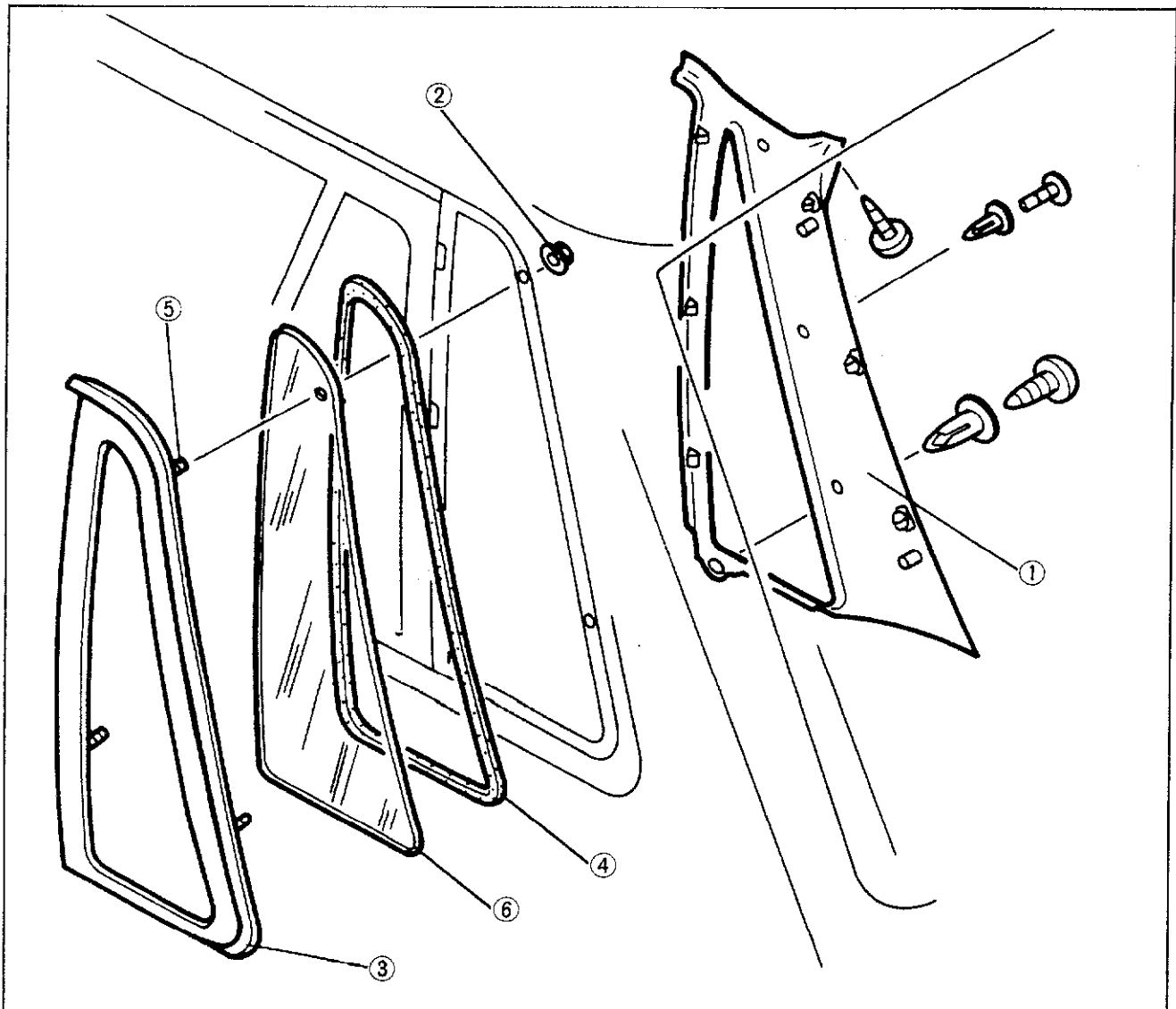

63U14X-080

1. Rear side trim  
2. Nut

3. Pillar trim  
4. Seal rubber

5. Stud  
6. Glass

MOLDING

STRUCTURAL VIEW

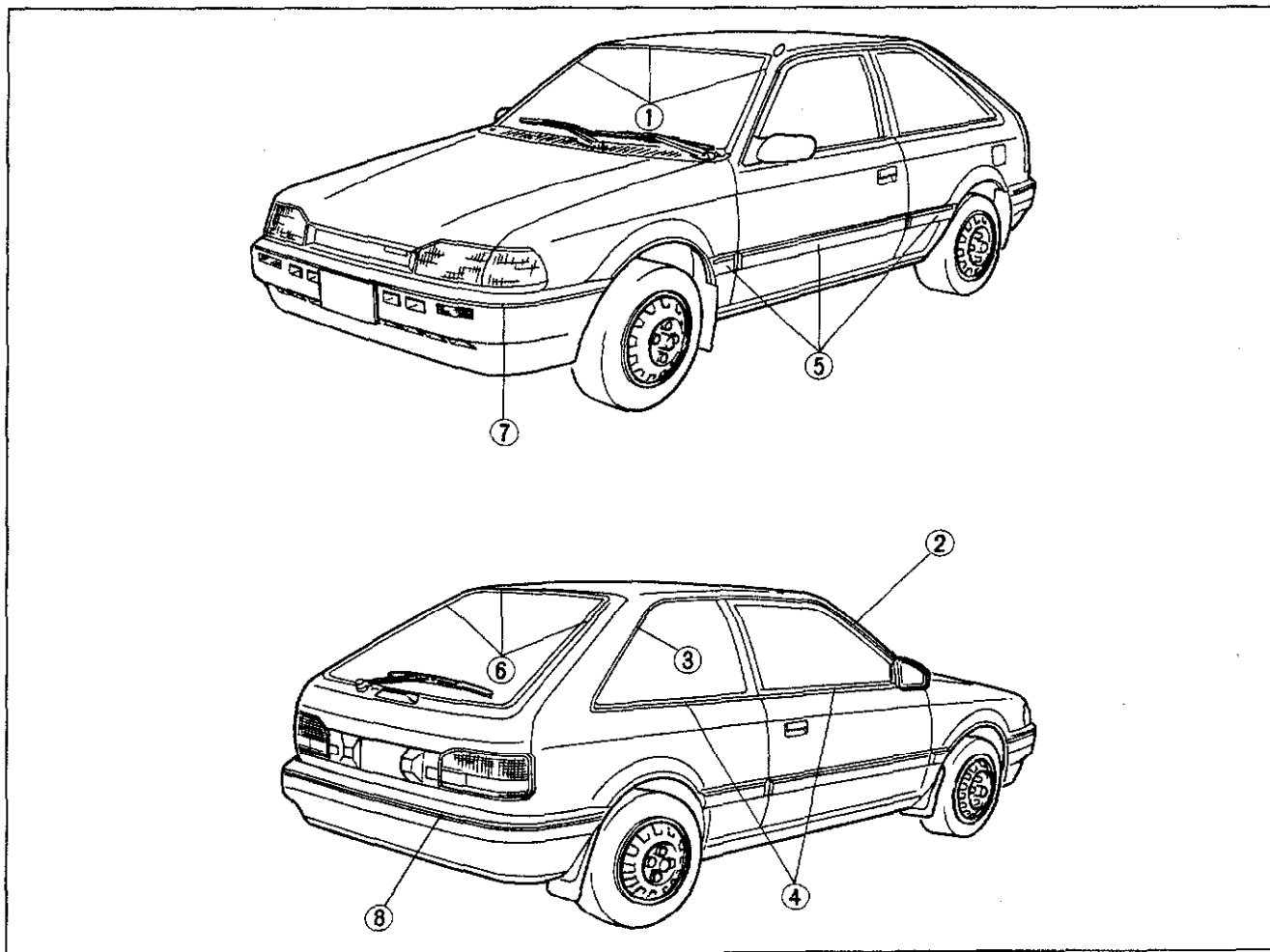

63U14X-081

- |  |                             |                         |
|--|-----------------------------|-------------------------|
| 1. Front window upper molding and side molding | 4. Belt-line molding        | 7. Front bumper molding |
| 2. Front drip molding                          | 5. Side protector molding   | 8. Rear bumper molding  |
| 3. Rear drip molding                           | 6. Back door window molding |                         |

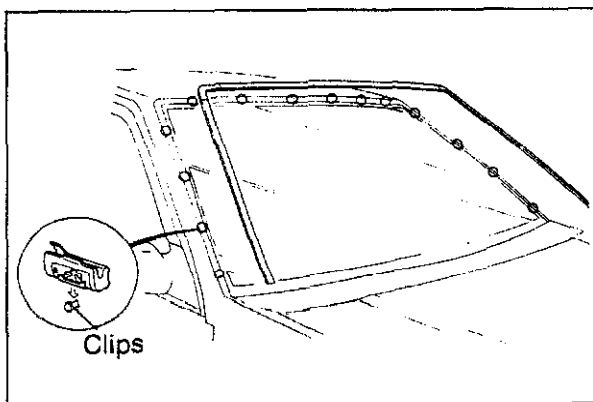

63U14X-082

**FRONT WINDOW UPPER MOLDING AND SIDE MOLDING**

**Removal and Installation**

1. Using a molding remover, remove the side molding from one side first.
2. Remove the upper molding.
3. Check that all the molding clips are in place and are in good condition when reinstalling the moldings.

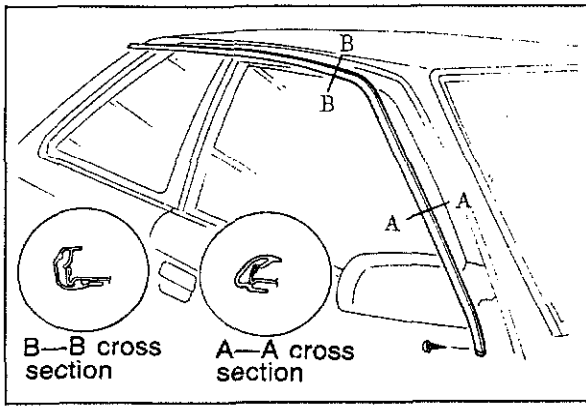

63U14X-083

## FRONT DRIP MOLDING Removal and Installation

1. Remove the attaching screw of the front pillar.
2. Remove the ends of the roof rail and molding.
3. Remove the molding by twisting it so that the lower part of the molding is removed first. (Do not damage the molding)
4. Install in the reverse order of removal.

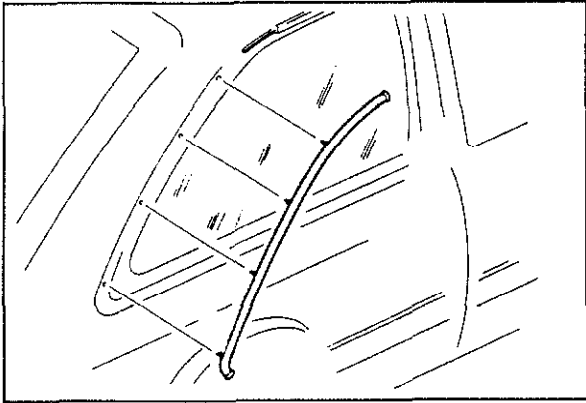

63U14X-084

## REAR DRIP MOLDING Removal and Installation

1. Insert the tip of a standard screwdriver between the roof rail and drip molding and lift the end of the molding.  
(Be careful not to scratch the molding)
2. Remove the molding by twisting with both hands, beginning at the lower side.
3. Install in the reverse order of removal.

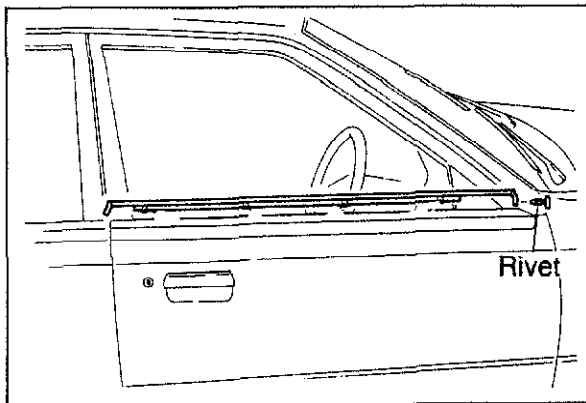

63U14X-085

## BELTLINE MOLDING Removal and Installation

1. Pry up the clip at the end of the beltline molding.
2. Remove the sail outer garnish.
3. Remove the beltline molding mounting screw and mounting rivet.
4. Lift the molding up to remove it.
5. Install in the reverse order of removal.

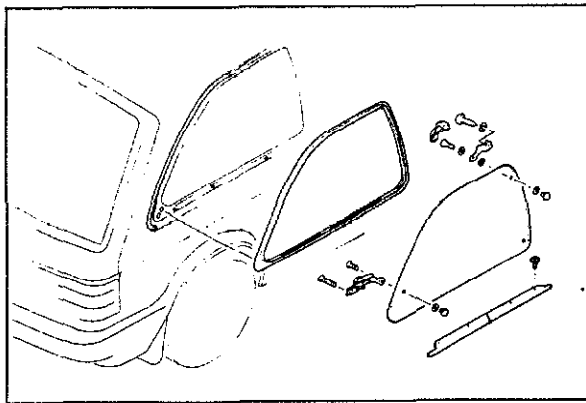

63U14X-086

## BELTLINE MOLDING (3 DOOR HATCHBACK) Removal and Installation

1. Remove the quarter window glass.
2. Remove the weatherstrip.
3. Remove the beltline molding mounting screw, and remove the molding.
4. Install in the reverse order of removal.



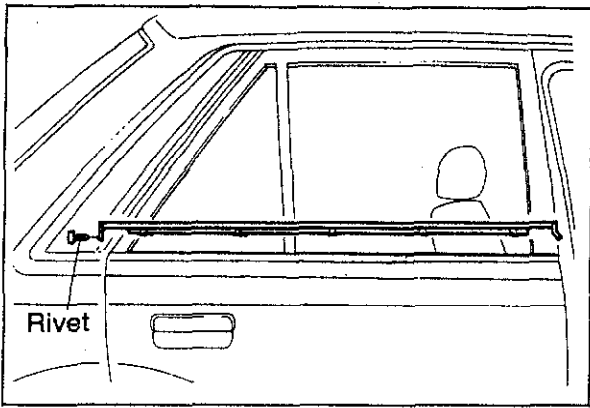

63U14X-087

## BELTLINE MOLDING (5 DOOR HATCHBACK)

### Removal and Installation

1. Pry up the clip at the end of the beltline molding.
2. Remove the sail outer garnish.
3. Remove the beltline molding mounting screw and mounting rivet.
4. Lift the molding up to remove it.
5. Install in the reverse order of removal.

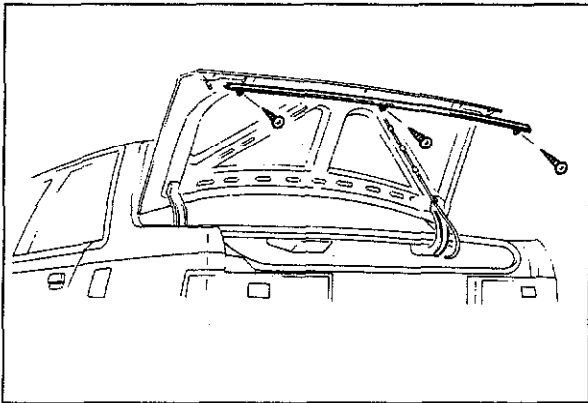

63U14X-088

## TRUNK LID MOLDING

### Removal and Installation

1. Remove the trunk lid molding mounting screws.
2. Install in the reverse order of removal.

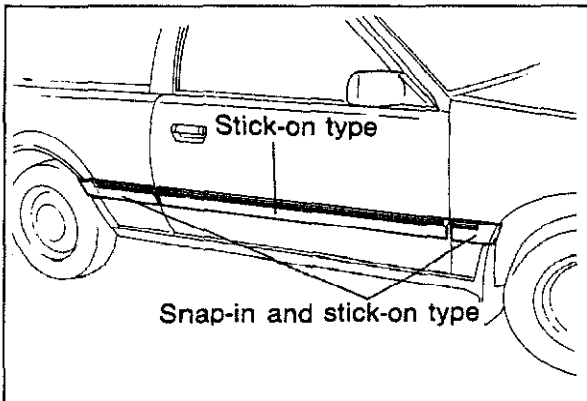

63U14X-089

## SIDE PROTECTOR MOLDING (SNAP-IN AND STICK-ON TYPE)

### Note

As shown in the figure, the method of installation varies according to the installation location.

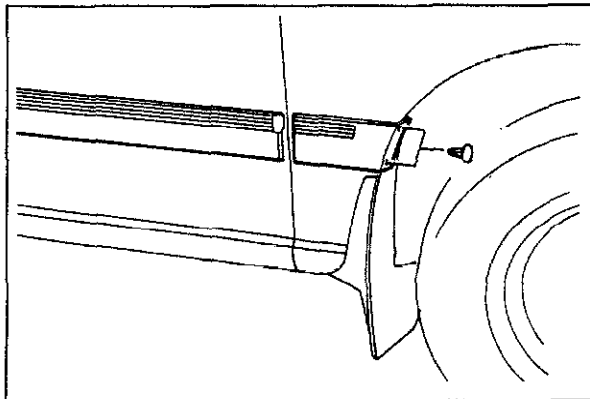

63U14X-090

### Removal and Installation

1. Remove the rivets and cut the molding free from the body.

### Note

- a) Wide molding is a snap-on type. Do not cut the pins off when removing the glue.
- b) Do not damage the painted surface.

2. Install in the reverse order of removal.

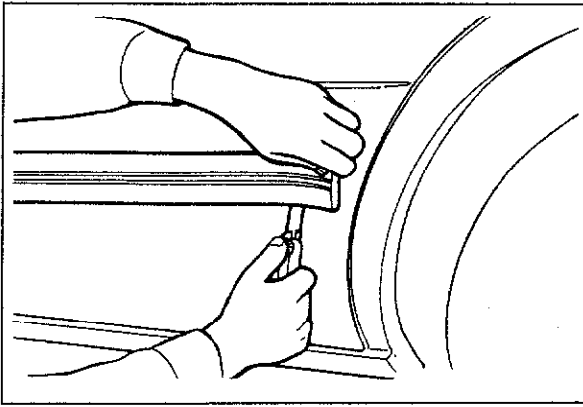

63U14X-091

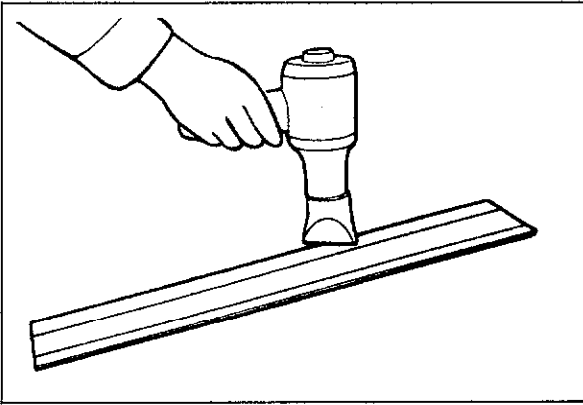

63U14X-092

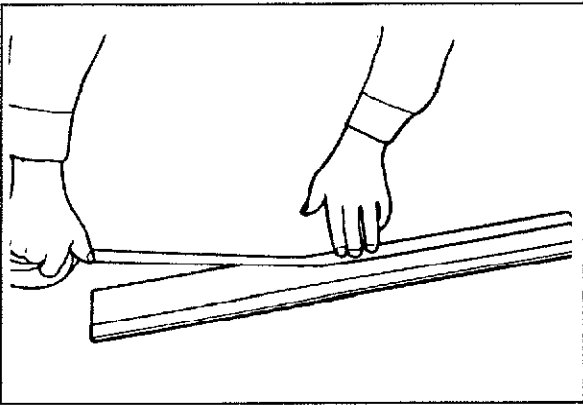

63U14X-093

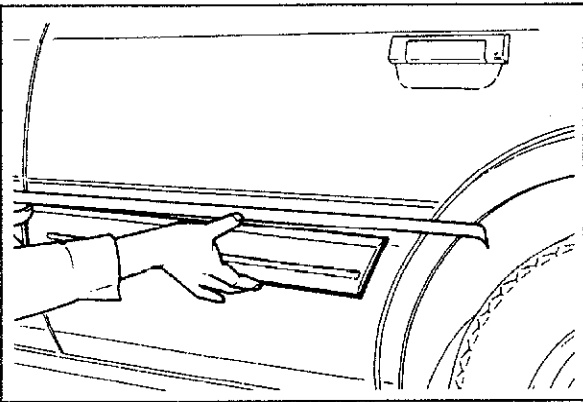

63U14X-094

## SIDE PROTECTOR MOLDING (STICK-ON TYPE) Removal

1. Being careful not to scratch the painted surface, use a knife to cut away the adhesive from the molding.
2. Remove any adhesive remaining on the body or the molding.

### Note

**Remove as much adhesive as possible without damaging the surface.**

3. If the adhesive is hard to remove, use a blow dryer to soften it.

## Installation

1. Remove any grease from the body and molding surfaces.
2. Use masking tape to mark the location of installation on the body.
3. Attach two-sided molding tape to the molding.

4. Align the molding to the body and attach it securely.

### Note

**The adhesion strength is decreased below 20°C (68°F), so it is best to warm the body surface before installing.**

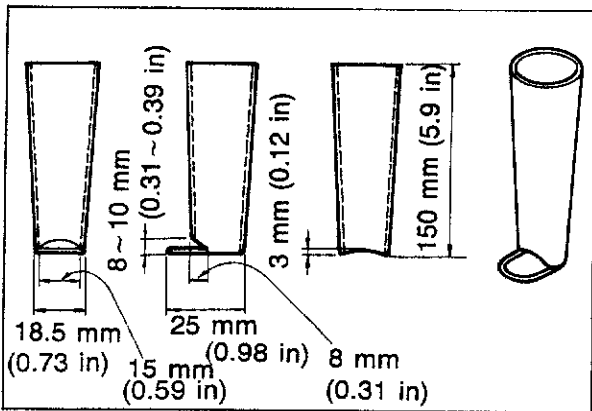

63U14X-025

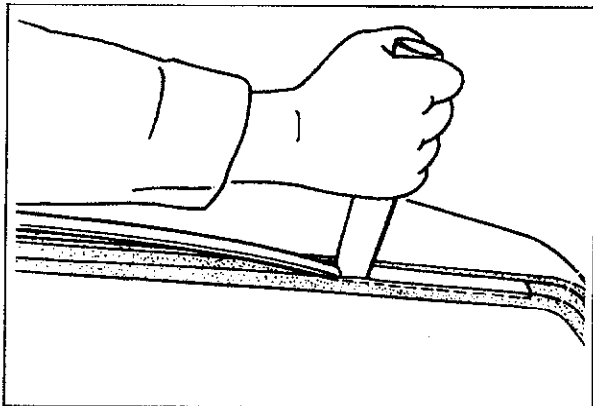

63U14X-096

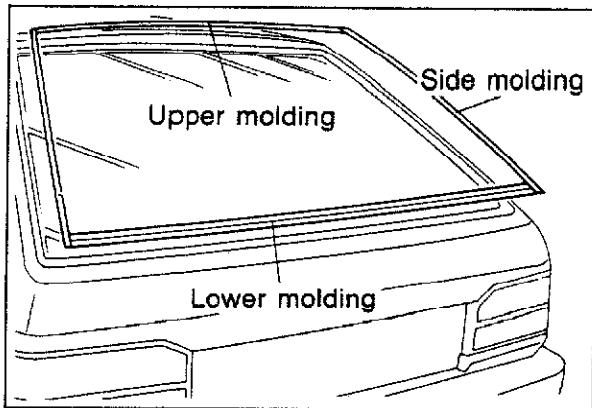

63U14X-097

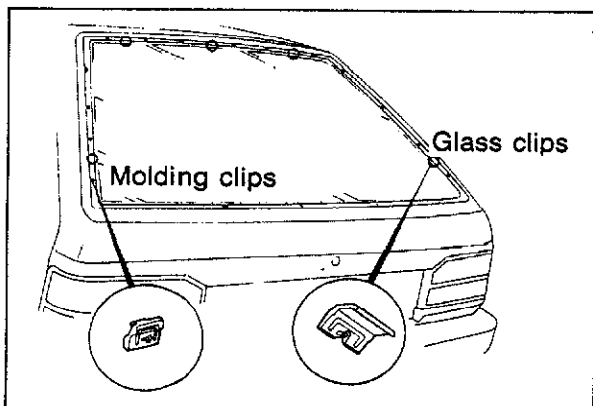

63U14X-098

## REAR WINDOW MOLDING (SEDAN) Removal and Installation

1. Use a suitable tool to remove and install the molding.
2. Install the molding after installing the window glass onto the body.
3. Coat the surface of the weatherstrip that contacts the molding with soapy water.
4. Wedge the tool into the groove in the weatherstrip to mount the molding.
5. After pressing about 10 cm (0.39 in) of the molding into the weatherstrip, gradually press in the rest of the molding by moving the tool without removing it from the groove.

## BACK DOOR GLASS WINDOW MOLDING (HATCHBACK) Removal

1. Remove the wiper arm with blade, luggage compartment light assembly, back door trim, and the wiper motor.
2. Remove the back door side moldings.
3. Remove the grommets and nuts, and remove the back door lower molding.
4. Remove the back door upper molding.

## Installation

1. Attach the molding clips.

## Caution

**Do not mix the molding clips with glass clips their positions are as shown.**

# 14 MOLDING, EMBLEM

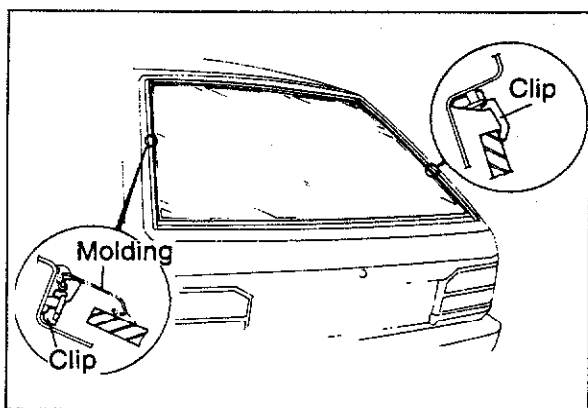

63U14X-099

2. Install the lower, upper and side moldings.
3. Install the wiper motor, back door trim, luggage compartment light assembly, and wiper arm with blade.

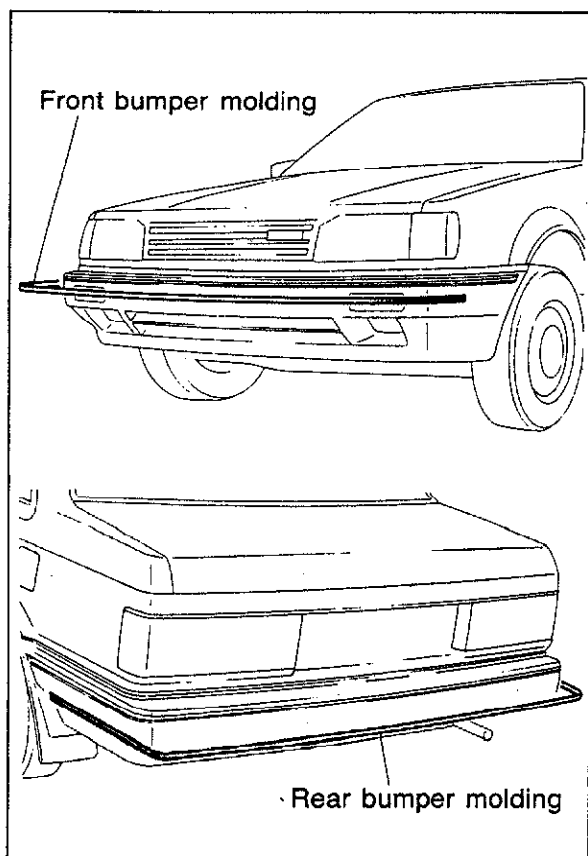

63U14X-100

## BUMPER MOLDING

### Removal and Installation

1. Remove the bumper molding by prying it with a protected screwdriver. (start removing it at the molding end.)
2. Snap the molding in starting at one end and proceed step by step toward the other end.

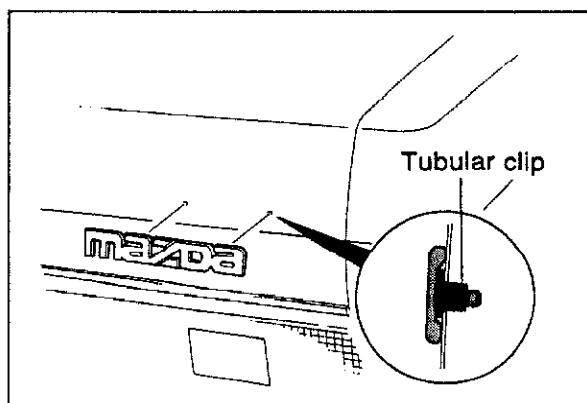

63U14X-101

## EMBLEM

### MAZDA ORNAMENT

#### Removal and Installation

1. Remove the ornament by compressing the tubular clip and pushing the emblem out from inside the trunk.
2. To install, insert the tubular clip into the trunk lid, and then insert the ornament.

SLIDING SUNROOF

STRUCTURAL VIEW

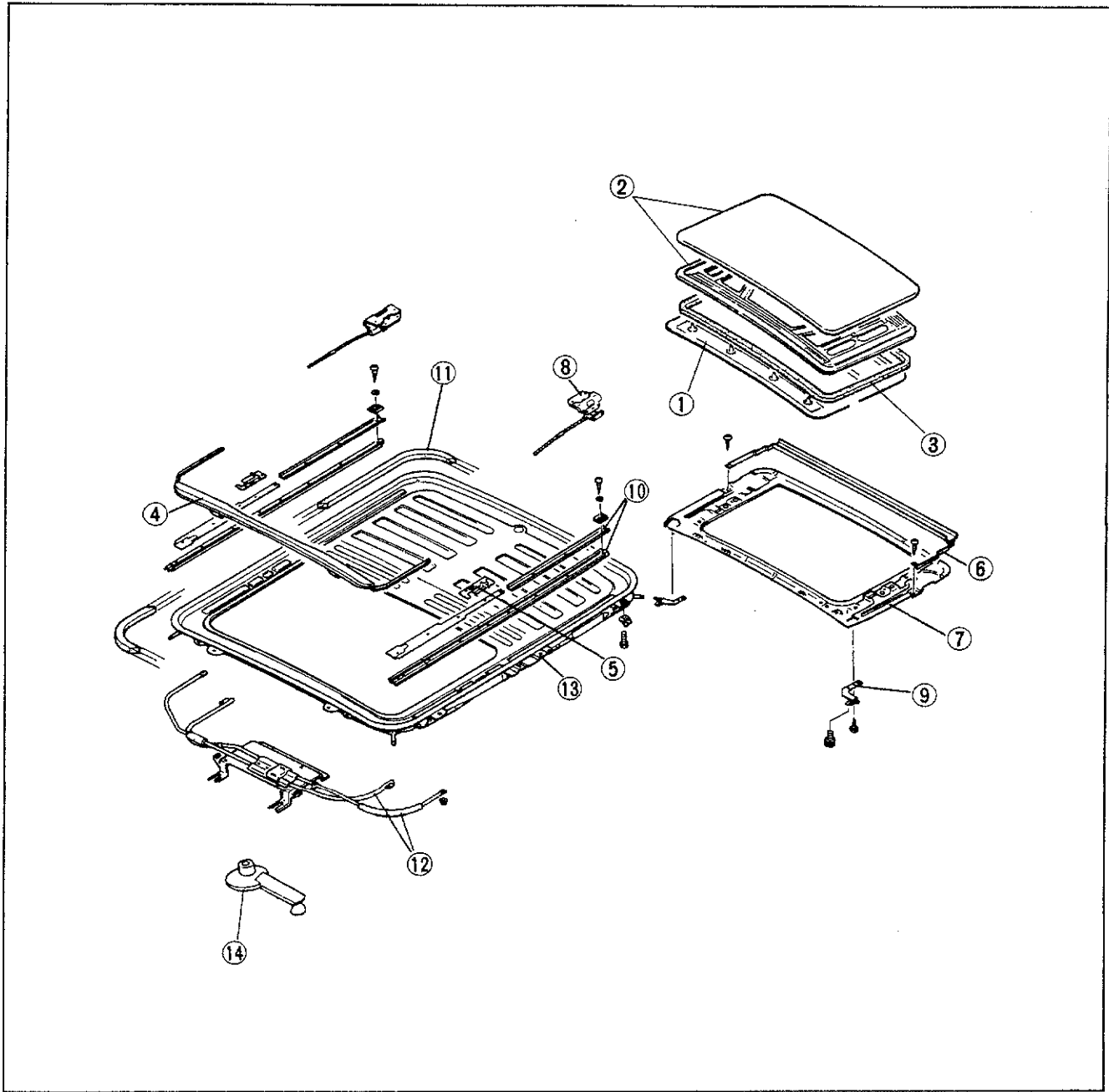

83U14X-045

- 1. Sunroof trim
- 2. Sliding panel
- 3. Weatherstrip
- 4. Deflector
- 5. Stopper

- 6. Rail assembly
- 7. Lower panel
- 8. Guide bracket (rear)
- 9. Guide bracket (front)
- 10. Guide rail assembly

- 11. Packing
- 12. Tube assembly
- 13. Frame assembly
- 14. Regulator

# 14 SLIDING SUNROOF

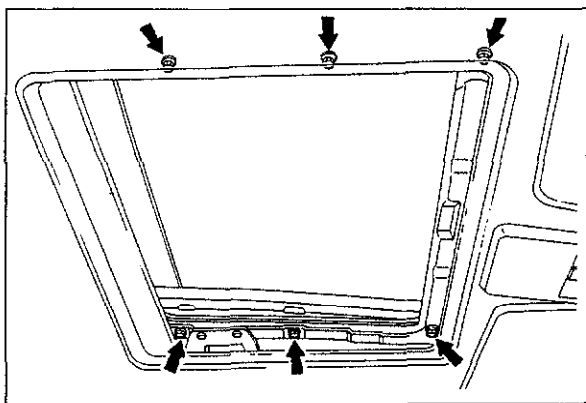

83U14X-046

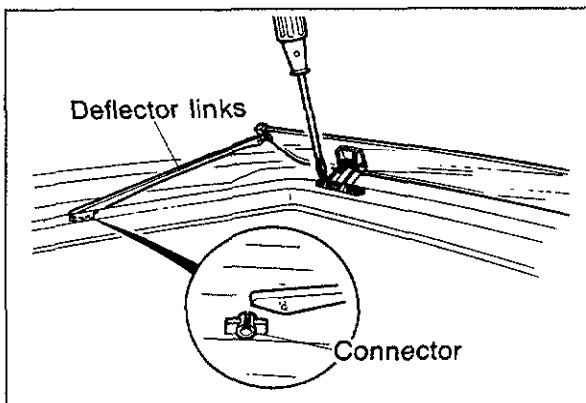

83U14X-047

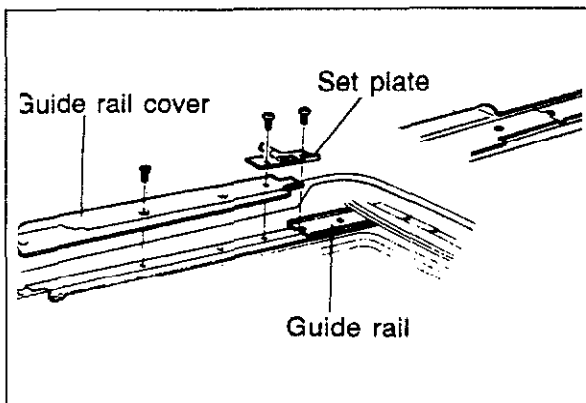

83U14X-048

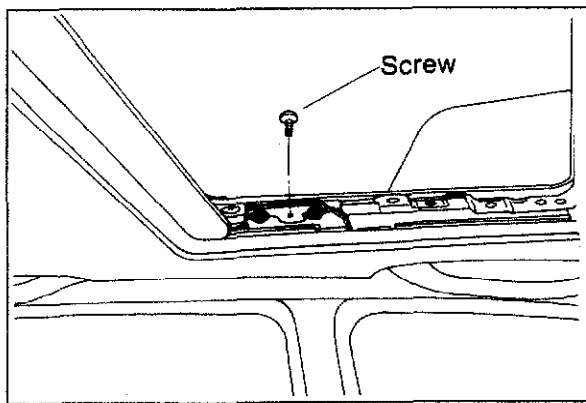

83U14X-049

## REMOVAL

1. Remove the sunroof trim.
2. Remove the installation nuts for the sliding panel and lower panel.
3. Remove the sliding panel by pushing it upward from inside the vehicle.
4. Completely open the lower panel.

5. Disconnect the deflector links from the connectors remove the deflector.

### Note

**Hold the deflector down while disconnecting the deflector links.**

6. Remove the screws and the set plate.
7. Remove the screw and remove the guide rail cover.

8. Remove the screws and the bracket assembly, remove the screws from the drip rail link, and then remove the lower panel upward.

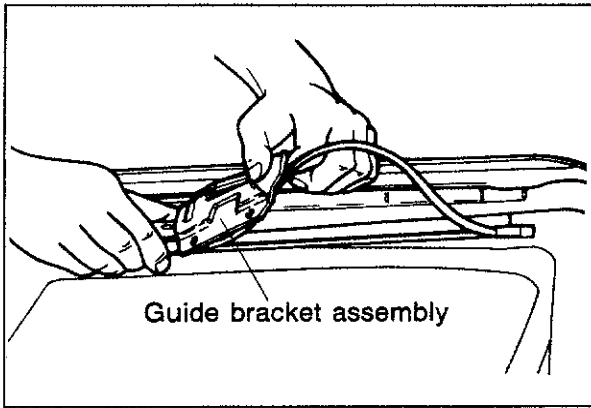

83U14X-050

9. Remove the guide bracket assembly from the rail, and then pull the driving cable out.

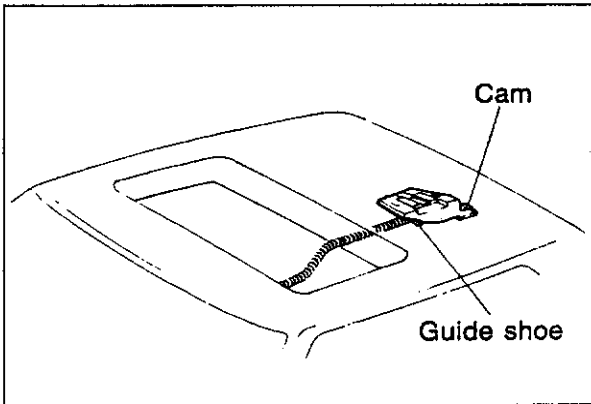

63U14X-112

## INSTALLATION

1. Insert the driving cable into the tube assembly.

### Note

Apply an ample amount of grease to the driving cable and insert the cable through the end of the assembly. Apply an ample amount of grease on the sliding surfaces of the cam and guide shoe.

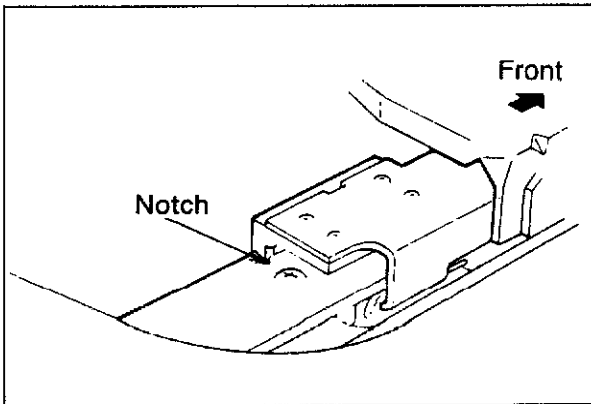

63U14X-113

2. Properly adjust the left and right positions of the driving cable.

### Note

Insert the guide rail into its bracket and insert the rear end of the bracket into the notch at the rear of the rail.

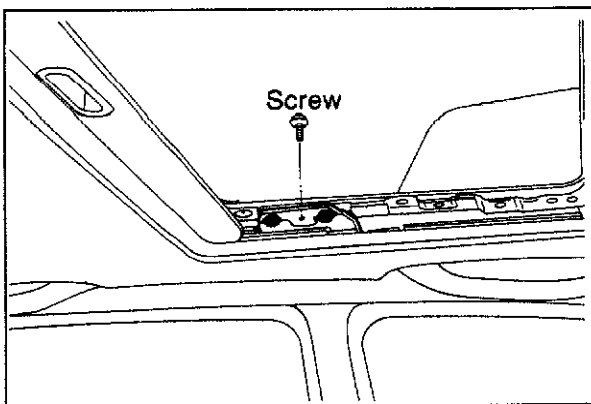

83U14X-051

3. Install the lower panel to the guide bracket assembly screw(s).

# 14 SLIDING SUNROOF

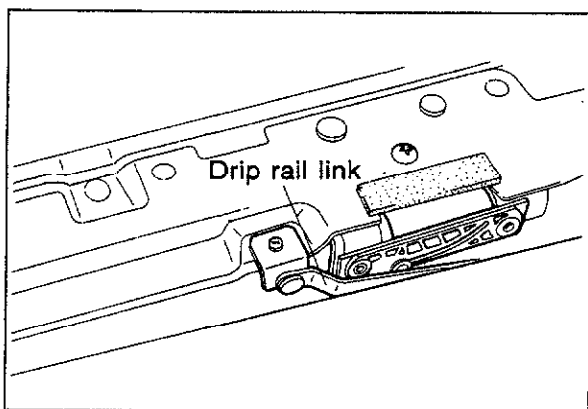

83U14X-052

4. Pull out the drip rail from the rear, and tighten the link.

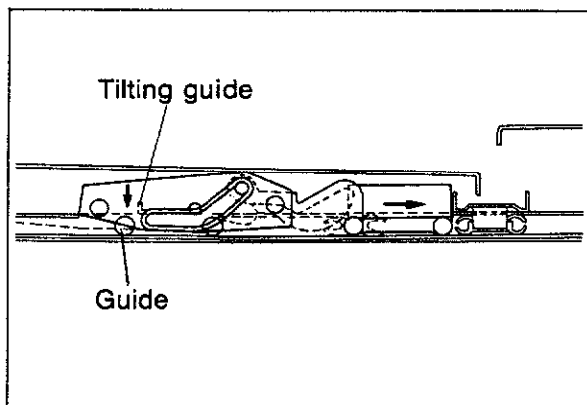

83U14X-053

5. Turn the regulator and open the lower panel fully.

### Note

Because the lower panel and roof panel might interfere with each other when the lower panel is opened, check that the guide roller is completely fitted into the guide rail, as shown in the figure.

Turn the regulator while pushing the cable.

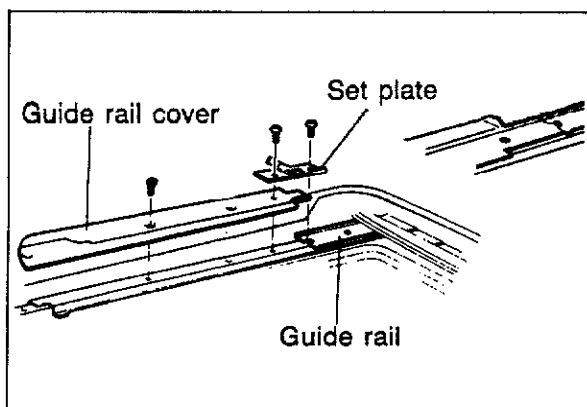

83U14X-054

6. Install the guide rail cover, and the set plate.

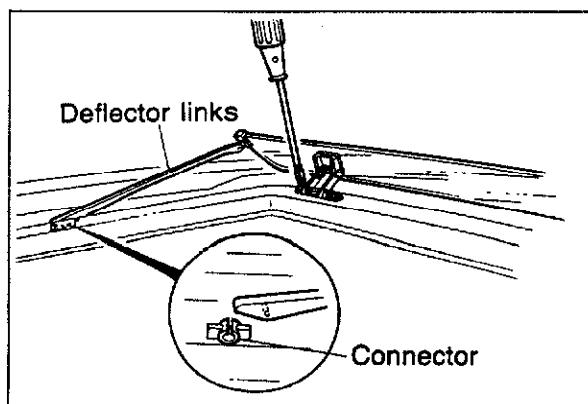

83U14X-055

7. Install the deflector and connect the deflector links.



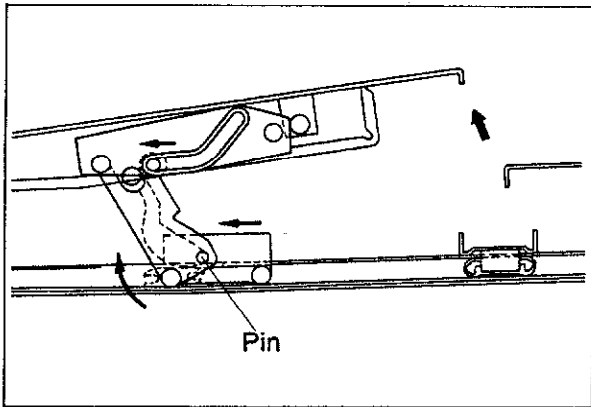

83U14X-056

8. Use the regulator and check the sliding operation of the sunroof, also check the tilt up and tilt down operations.

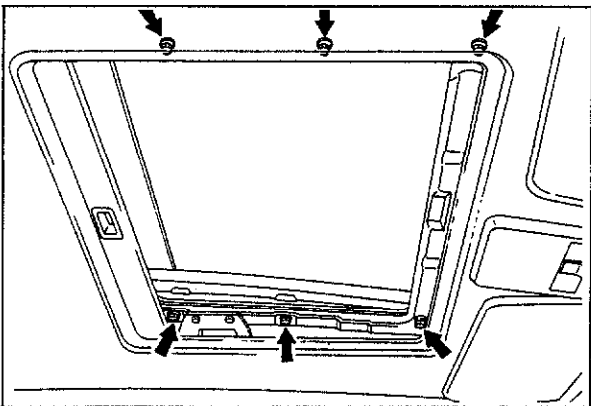

83U14X-057

9. Install the sliding panel.

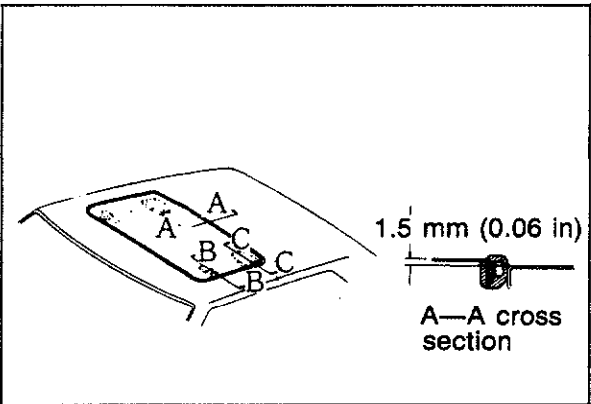

83U14X-026

10. Adjust the height of the slide panel.

(Cross-section A-A)

Adjust so that the height difference between the outer panel and roof panel is **1.5 mm (0.06 in)** or less.

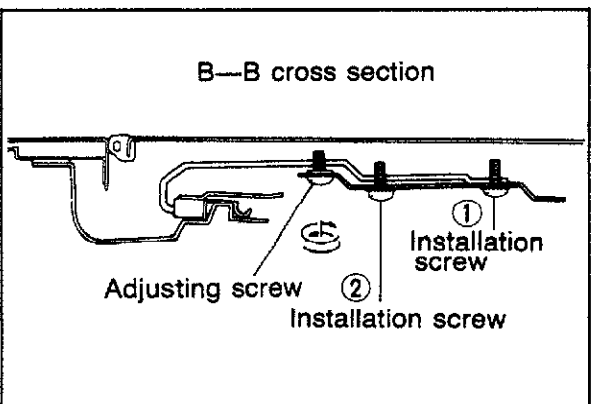

63U14X-125

(Cross-section B-B adjustment)

- (1) Loosen installation screws (1) and (2).  
If the adjustment is only about **2 mm (0.08 in)** don't loosen screw (1).
- (2) Turn the adjusting screws to adjust.  
Turning to the right raises, and to the left lowers.
- (3) Tighten installation screws (1) and (2).

# 14 SLIDING SUNROOF

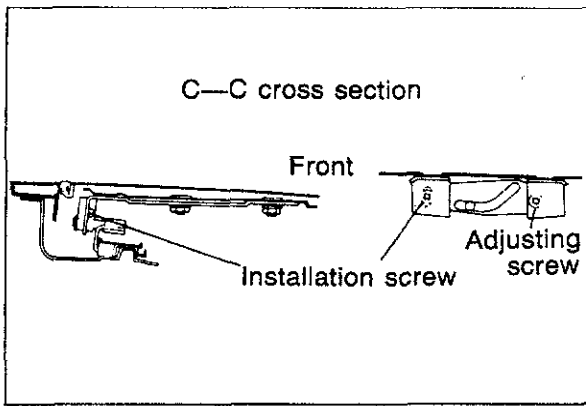

83U14X-027

(Cross-section C-C adjustment)

- (1) Loosen the installation screw and the adjusting screw.  
The adjustment will be easier if the installation screw is not loosened too much.
- (2) Adjust by moving the outer panel from the inside or outside.
- (3) Tighten the adjusting screw first, and then the installation screw.

### Caution

**If the outer panel operation seems "heavy", make the following adjustments.**

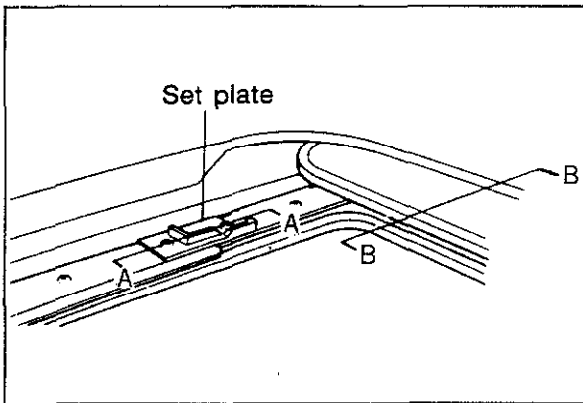

83U14X-046

11. Install the sunroof trim.

12. After installation is completed, check the operation and following points:

- (1) Is there any foreign material on the sliding parts of the sunroof?
- (2) When the sliding panel is opened, does the roof panel interfere with the rear part? If so, open the outer panel fully and move the stopper forward.

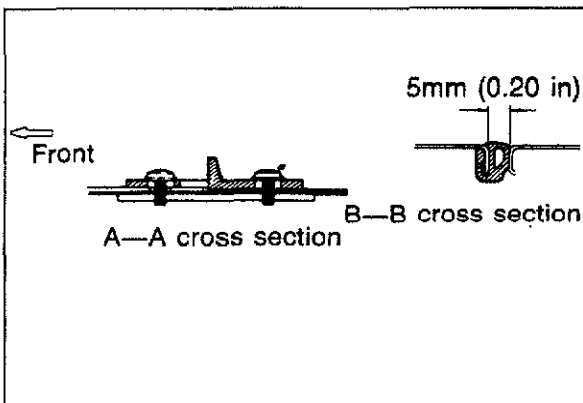

63U14X-131

### Caution

**If the stopper is moved too far forward, there might be a malfunction or leaking. Do not leave a gap of more than 5 mm (0.2 in) between the outer panel and roof panel.**

WINDSHIELD WIPER

REMOVAL AND INSTALLATION

- 1. Disconnect the battery negative cable.
- 2. Remove the parts in the sequence shown in the figure.
- 3. Install in the reverse order of removal.

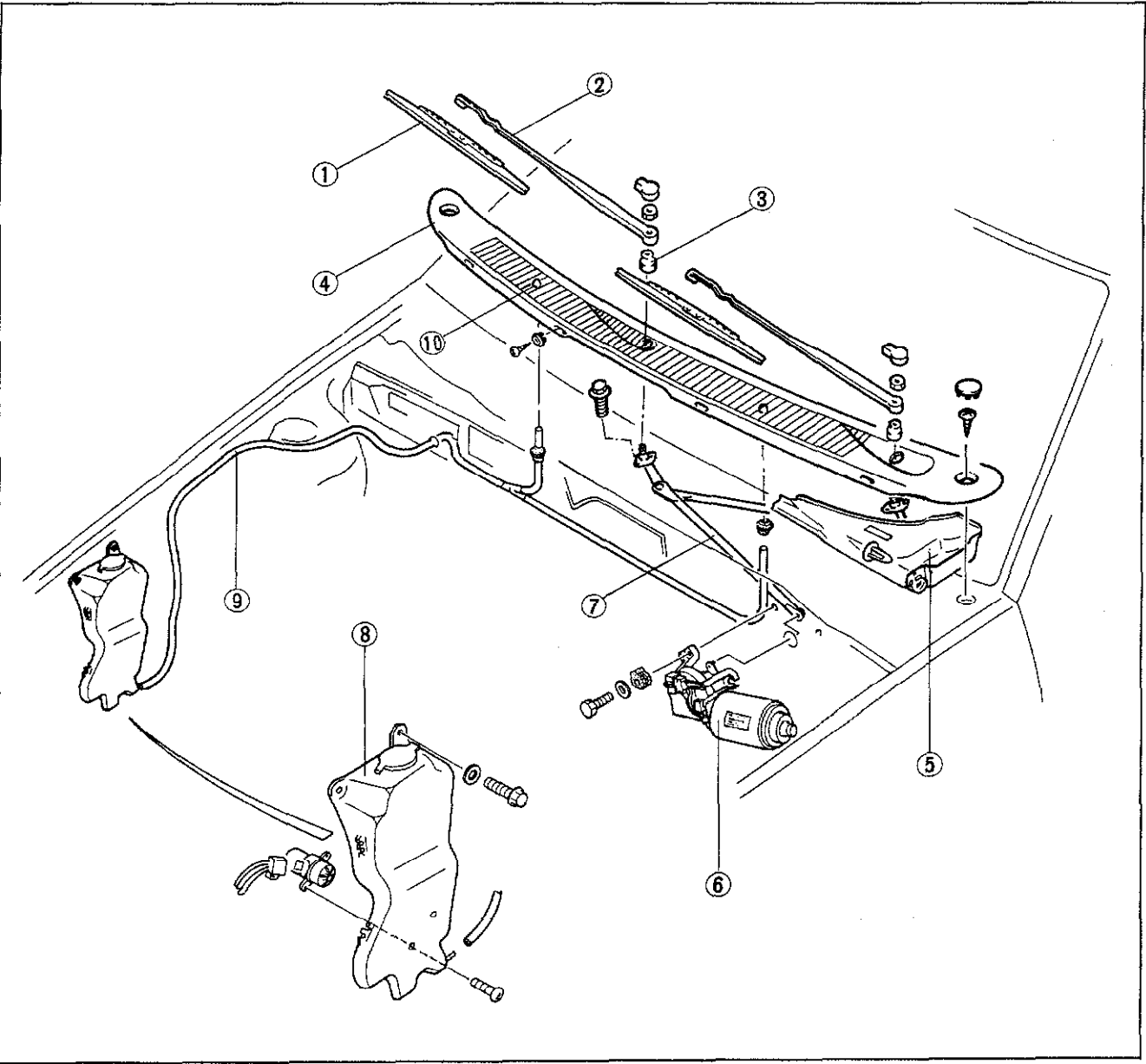

83U14X-028

- |                |                  |                   |
|----------------|------------------|-------------------|
| 1. Wiper blade | 5. Cover         | 9. Nozzle hose    |
| 2. Wiper arm   | 6. Wiper motor   | 10. Washer nozzle |
| 3. Seal rubber | 7. Link assembly |                   |
| 4. Cowl grill  | 8. Washer tank   |                   |

# 14 WINDSHIELD WIPER

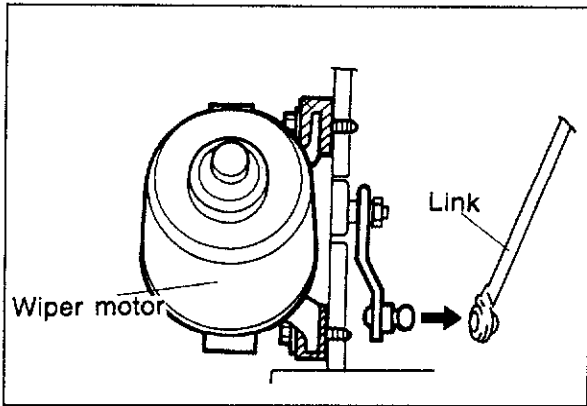

63U14X-133

## Wiper motor

To remove the wiper motor, insert a large standard screwdriver between the crank arm and the linkage and pry the linkage to separate it from the crank arm.

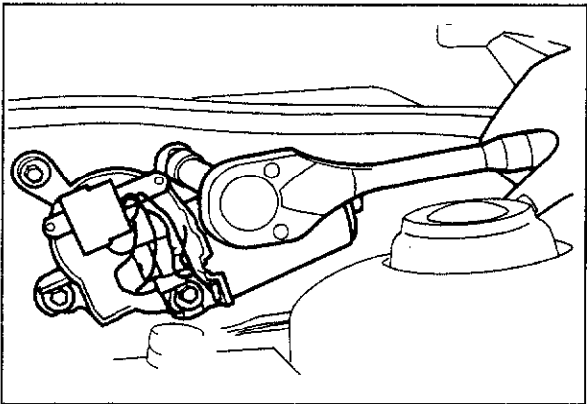

63U14X-134

Do not remove the motor and crank arm unless necessary, because the automatic-stop angle is fixed.

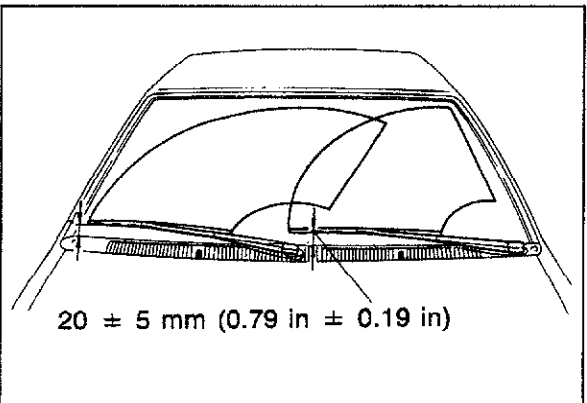

63U14X-135

## Adjustment of arm height

Adjust the arm height as shown in the figure.

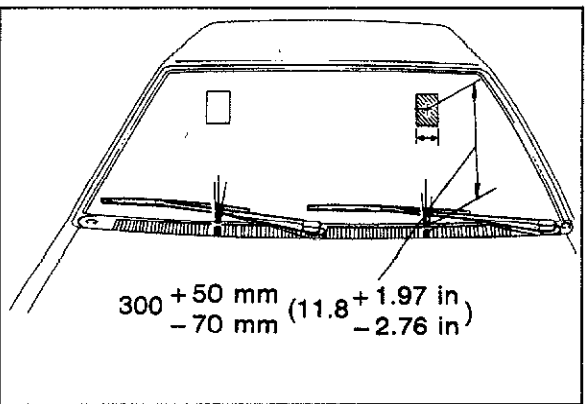

63U14X-136

## Adjustment of washer spray

Adjust the washer spray by inserting a needle or similar object into the spray hole of the nozzle and bend to adjust.

## REAR WINDOW WIPER

### REMOVAL AND INSTALLATION

1. Disconnect the battery negative cable.
2. Remove the parts in the sequence shown in the figure.
3. Install in the reverse order of removal.

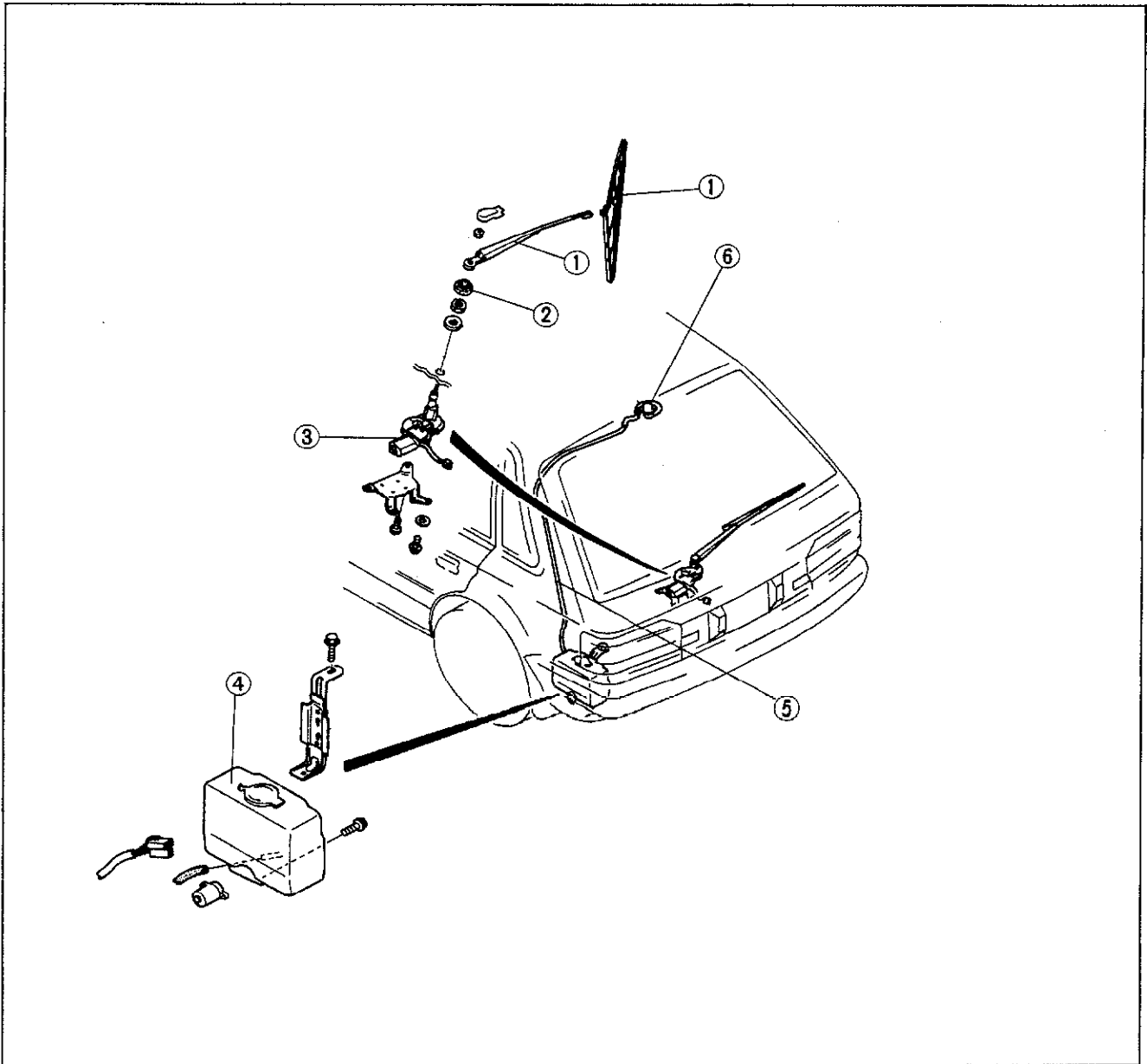

83U14X-029

- |                              |                |
|------------------------------|----------------|
| 1. Wiper arm and wiper blade | 3. Wiper motor |
| 2. Seal cap                  | 4. Washer tank |

- |                  |
|------------------|
| 5. Nozzle hose   |
| 6. Washer nozzle |

# 14 REAR WINDOW WIPER

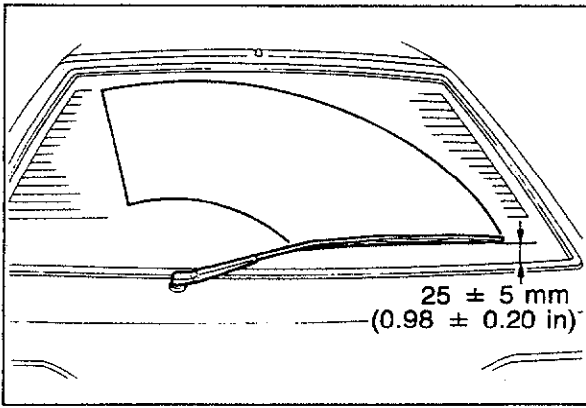

83U14X-030

## Adjustment of Arm Height

Adjust the height as shown in the figure.

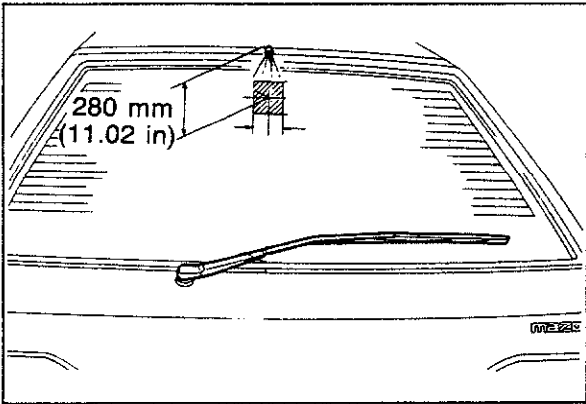

63U14X-139

## Adjustment of Washer Spray

Adjust the washer spray by inserting a needle or similar object into the spray hole of the nozzle and bend to adjust.

## INSTRUMENT PANEL

### REMOVAL AND INSTALLATION

1. Disconnect the battery negative cable.
2. Remove the parts in the sequence shown in the figure.
3. Install in the reverse order of removal.

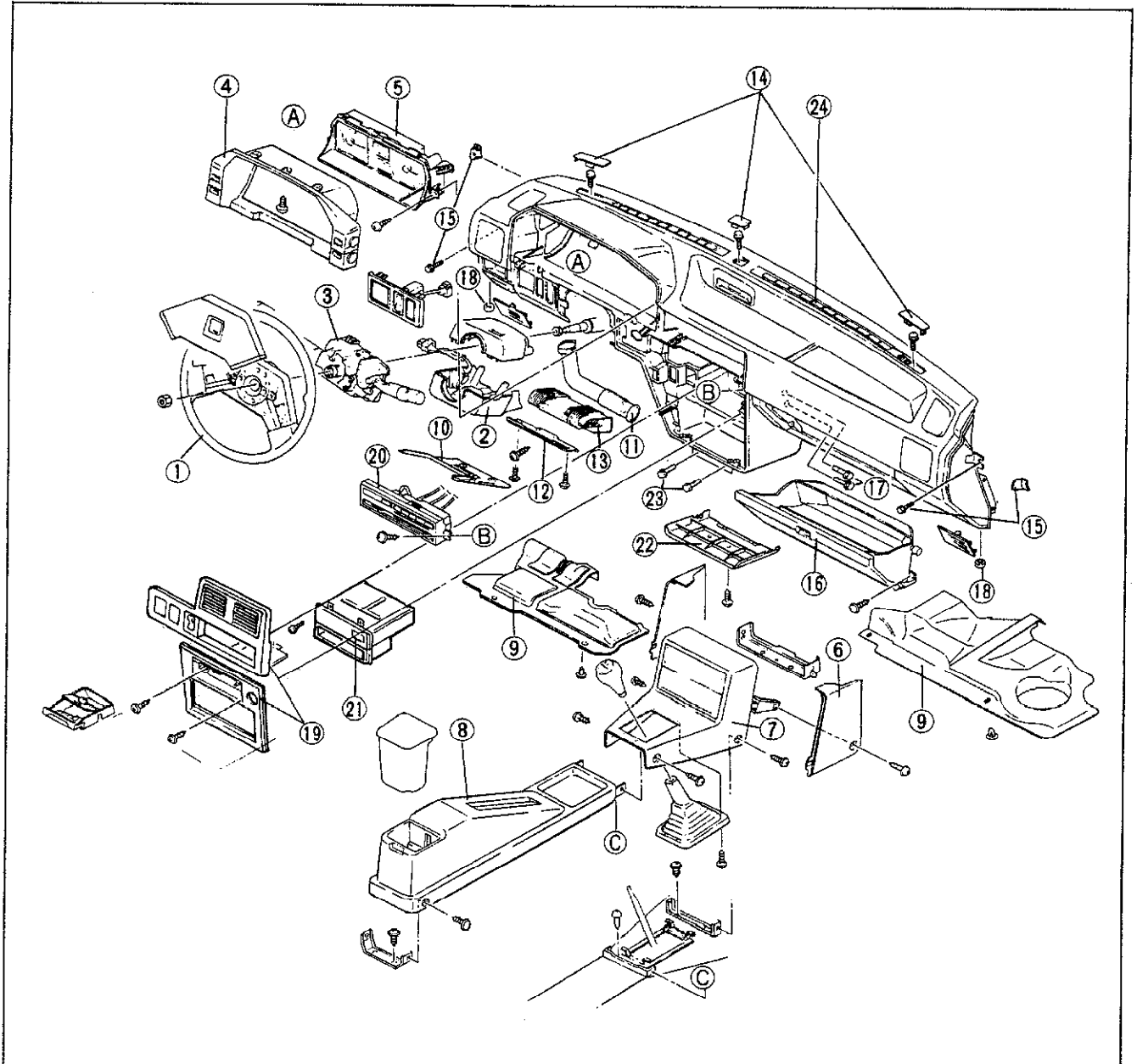

83U14X-013

- |                                      |                   |  |
|--------------------------------------|-------------------|--|
| 1. Steering wheel                    | 9. Under cover    | 18. Nuts (2)                           |
| 2. Column cover<br>(upper and lower) | 10. Lower panel   | 19. Center panel                       |
| 3. Combination switch                | 11. Duct          | 20. Heater control                     |
| 4. Meter hood                        | 12. Reinforcement | 21. Center differential lock<br>switch |
| 5. Meter                             | 13. Lower louver  | 22. Lower cover                        |
| 6. Side wall                         | 14. Bolts (3)     | 23. Bolts (2)                          |
| 7. Front console                     | 15. Bolts (2)     | 24. Instrument panel                   |
| 8. Rear console                      | 16. Glove box     |  |
|                                      | 17. Bolts (2)     |  |

# 14 INSTRUMENT PANEL

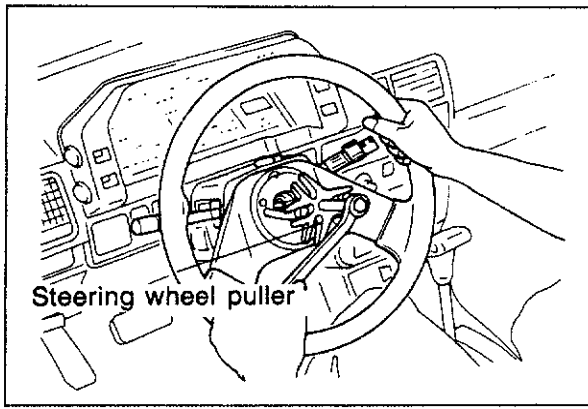

73U14X-507

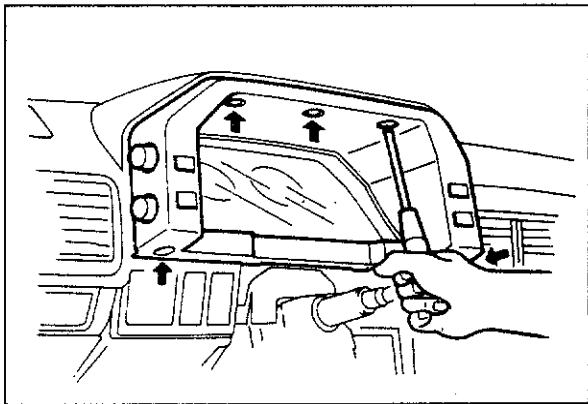

73U14X-508

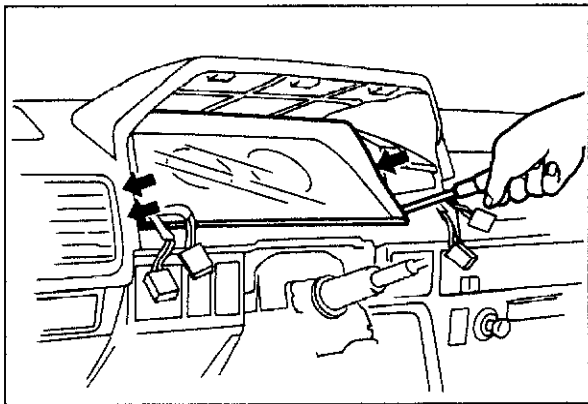

73U14X-509

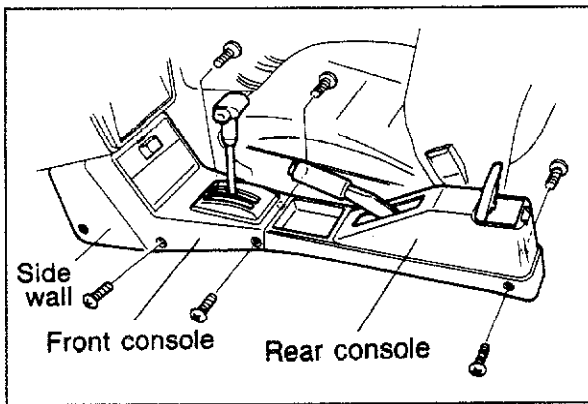

73U14X-510

## Removal

1. Remove the steering wheel.
2. Remove the column cover.
3. Remove the combination switch assembly.
4. Remove the attaching screws and remove the meter hood.
5. Remove the attaching screws.
6. Disconnect the speedometer cable and the meter connector.
7. Remove the meter assembly.
8. Remove the attaching screws and remove the side wall on both sides.
9. Remove the rear console.
10. Remove the front console and slide it rearward.
11. Disconnect the antenna feeder from the radio.



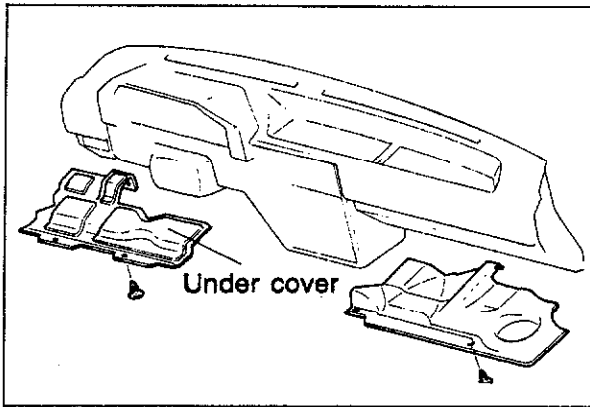

73U14X-511

12. Remove the fasteners and remove the under cover on both sides.

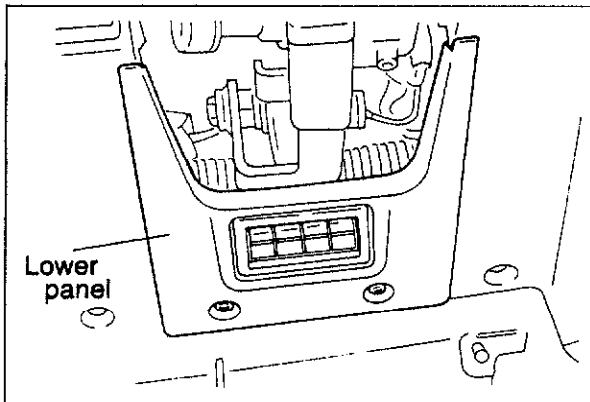

73U14X-512

13. Remove the screws and remove the lower panel.

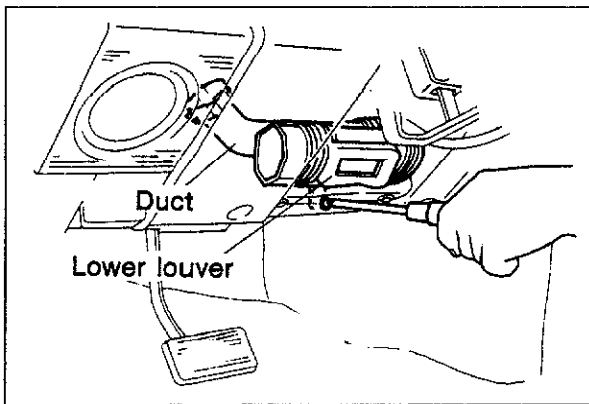

73U14X-513

14. Remove the screws and remove the lower louver and reinforcement.  
15. Remove the duct.  
16. Remove the hood release wire.

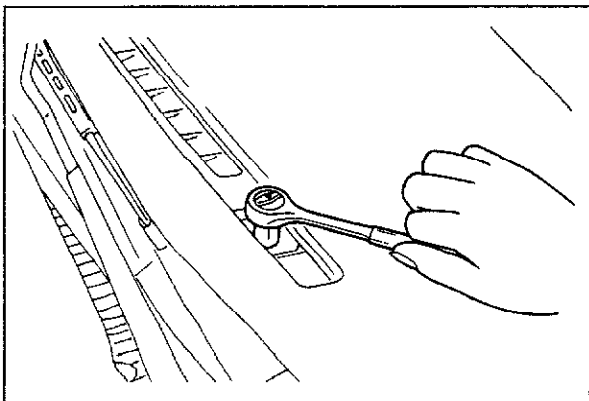

73U14X-514

17. Remove the center and side hole covers and remove the bolts.

# 14 INSTRUMENT PANEL

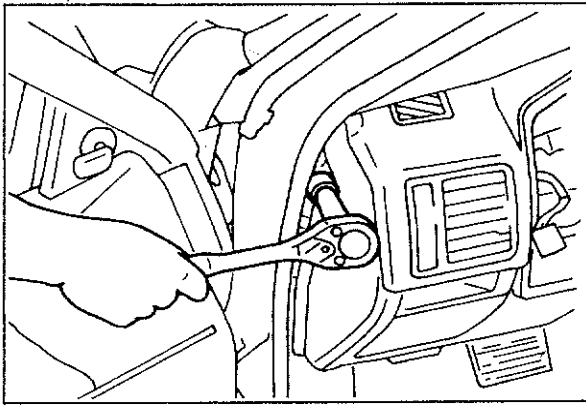

73U14X-515

18. Remove the side cover on both sides and remove the bolts.

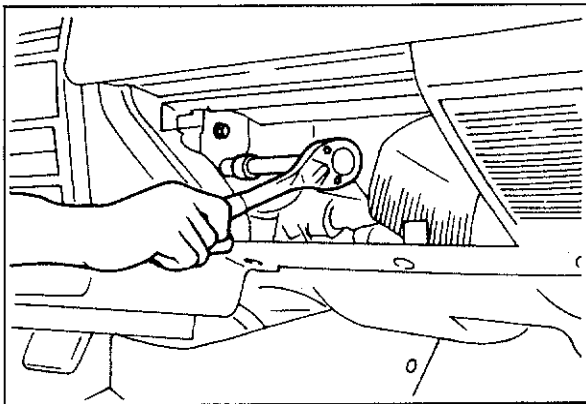

73U14X-516

19. Remove the screws and remove the center bracket attaching bolts after removing the glove box.

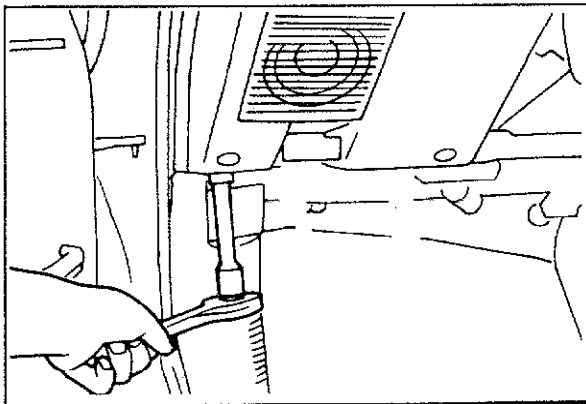

73U14X-517

20. Remove the side bracket attaching nut on both sides.

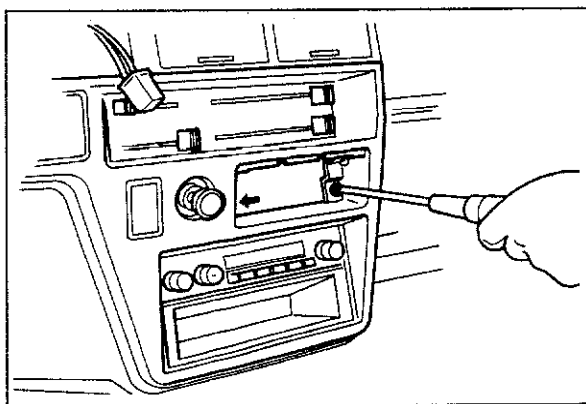

73U14X-518

21. Remove the ashtray and remove the screws.

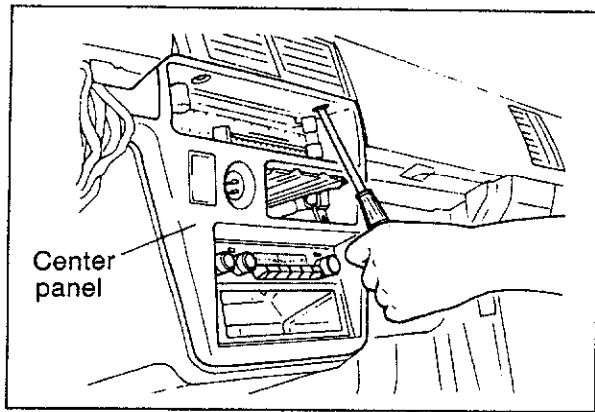

83U14X-031

22. Remove the screws and remove the center panel with the protected standard screw driver.
23. Disconnect the cigarette lighter connector and remove the light for illumination.

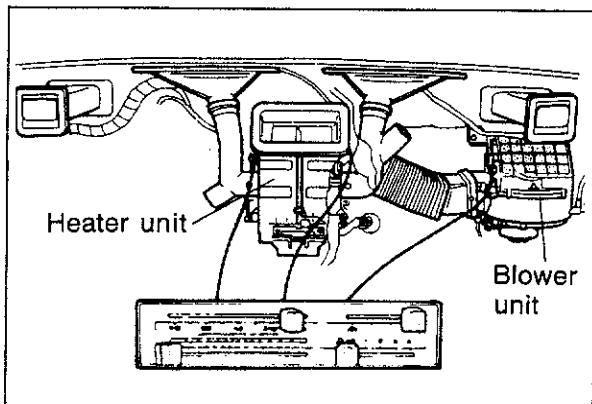

73U14X-520

24. Remove the heater control wires.

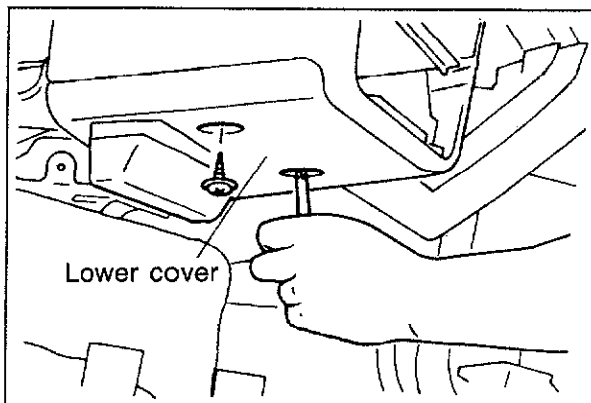

73U14X-521

25. Remove the screws and remove the lower cover.

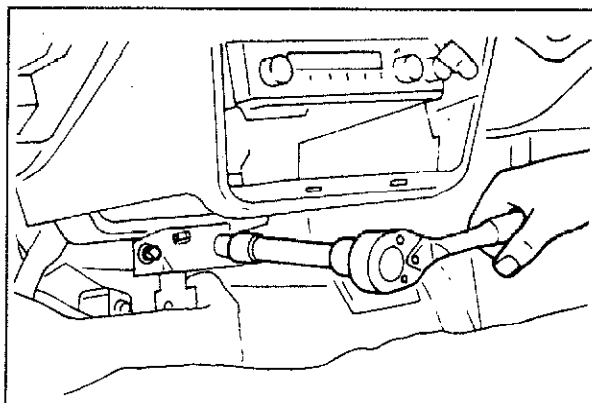

73U14X-522

26. Remove the instrument panel support bracket attaching bolts.
27. Disconnect the connectors between instrument panel harness and front harness.
28. Remove the instrument panel.

# 14 INSTRUMENT PANEL

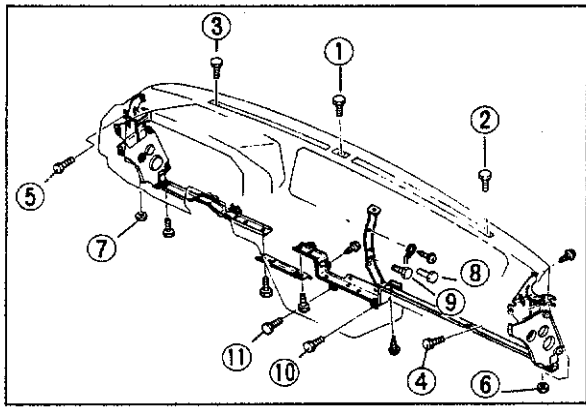

83U14X-014

## Installation

Install in the reverse order of removal.

### Note

#### 1. Tightening torque

- |       |       |                                 |
|-------|-------|---------------------------------|
| ① ② ③ | ..... | 4.2—6.2 N·m                     |
|       |       | (0.43—0.63 m·kg, 3.1—4.6 ft·lb) |
| ④ ⑤   | ..... | 8.8—12.8 N·m                    |
|       |       | (0.9—1.3 m·kg, 6.5—9.4 ft·lb)   |
| ⑥ ⑦   | ..... | 7.8—10.8 N·m                    |
|       |       | (0.8—1.1 m·kg, 5.8—8.0 ft·lb)   |
| ⑧ ⑨   | ..... | 8.8—12.8 N·m                    |
|       |       | (0.9—1.3 m·kg, 6.5—9.4 ft·lb)   |
| ⑩ ⑪   | ..... | 8.8—12.8 N·m                    |
|       |       | (0.9—1.3 m·kg, 6.5—9.4 ft·lb)   |

#### 2. Adjustment of heater control wires (Refer to page 15—119 and 120)

## SEAT

## DISASSEMBLY AND ASSEMBLY

1. Disassemble the parts in the sequence shown in the figure.
2. Assemble in the reverse order of disassembly.

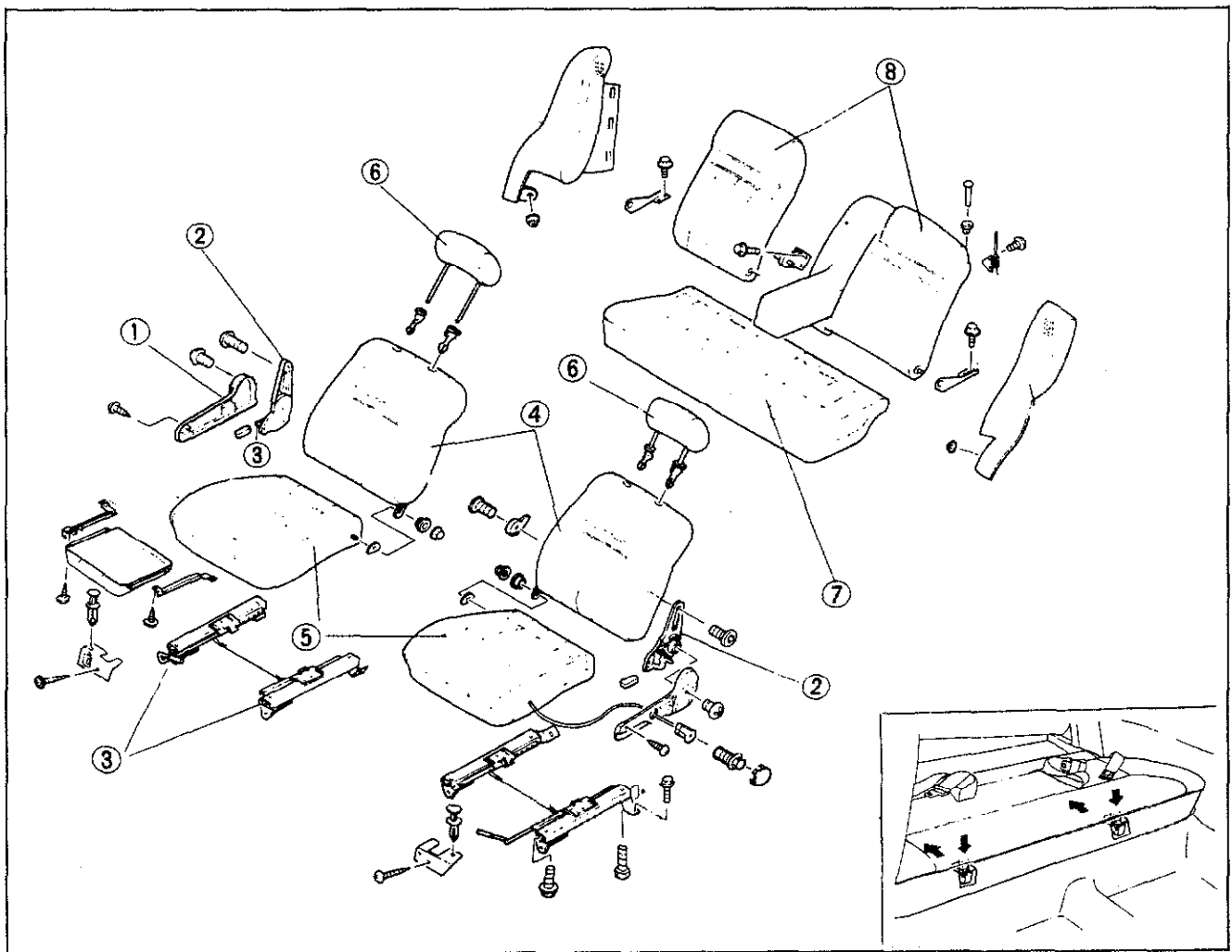

63U14X-142

1. Cover
2. Reclining knuckle
3. Seat adjuster

4. Front seat back
5. Front seat cushion
6. Head restraint

7. Rear seat cushion
8. Rear seatback

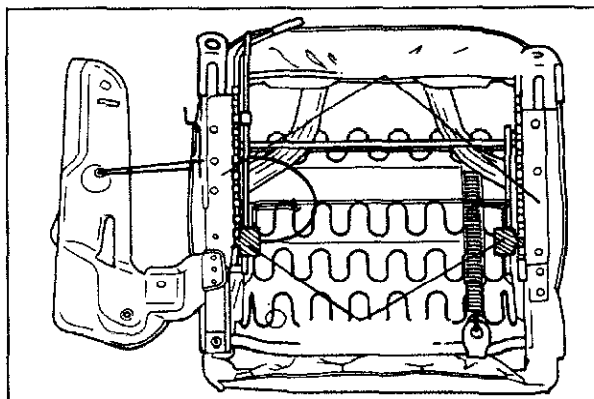

63U14X-143

## INSPECTION

- a) Check that the seat adjuster lever and reclining knuckle move smoothly. Apply grease to the moving parts.
- b) Check the adjustment lever for wear.
- c) Check the seat mounting bolts for looseness.

## SEAT BELT

### REMOVAL AND INSTALLATION

1. Remove the parts in the sequence shown in the figure.
2. Install in the reverse order of removal.

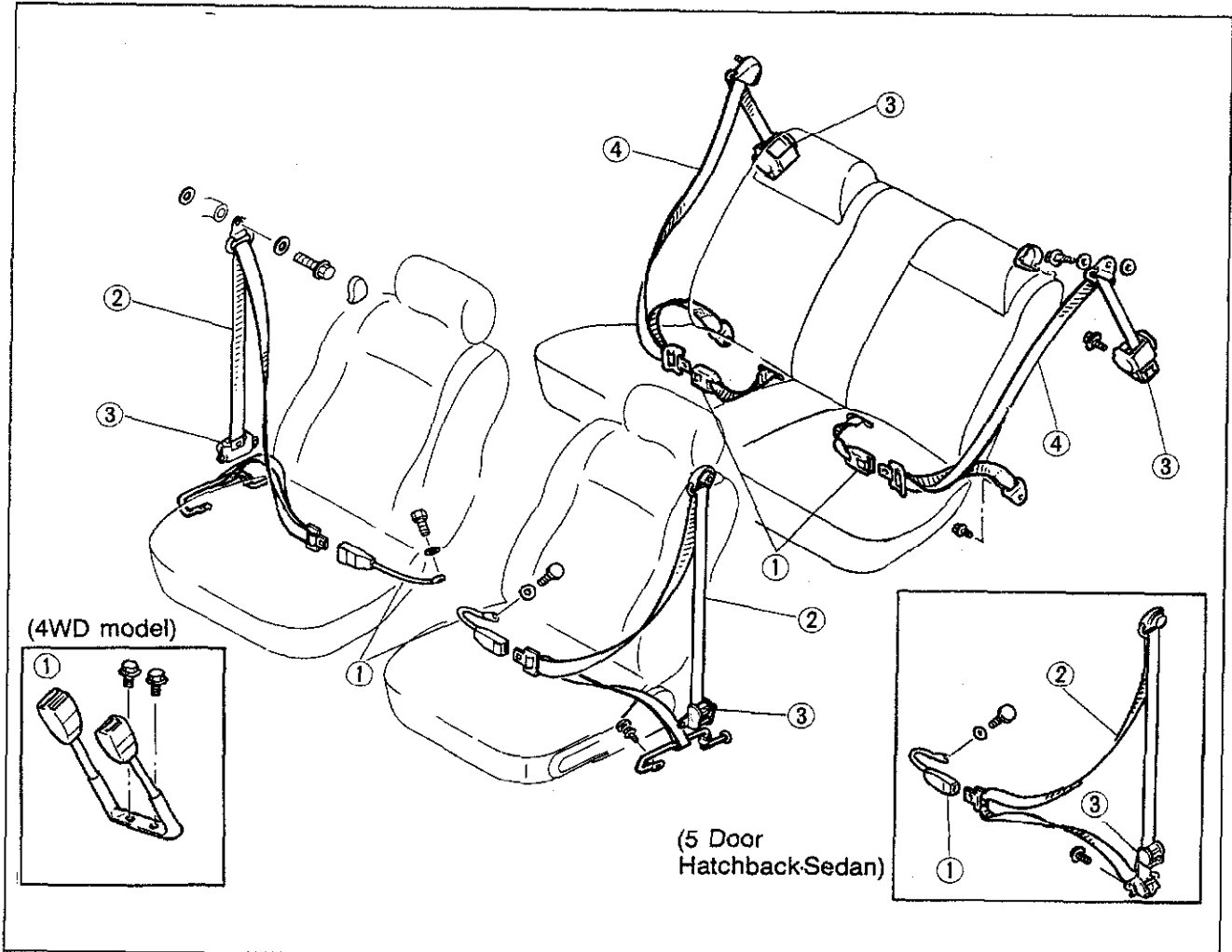

83U14X-015

1. Buckle
2. Front seat belt

3. Retractor (ELR)
4. Rear seat belt

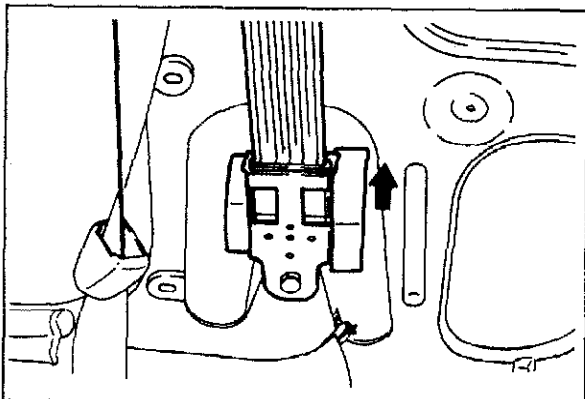

63U14X-145

### INSPECTION

1. Check that the belt can be pulled out smoothly and that it moves smoothly when worn.
2. Check the webbing for scars, tears or wear, and for deformation of the fittings.

### Warning

**Do not disassemble the buckle or ELR assembly.**

3. Check that the anchor works in the circumferential direction after the shoulder anchor bolt is tightened.

HEAD LINER

STRUCTURAL VIEW

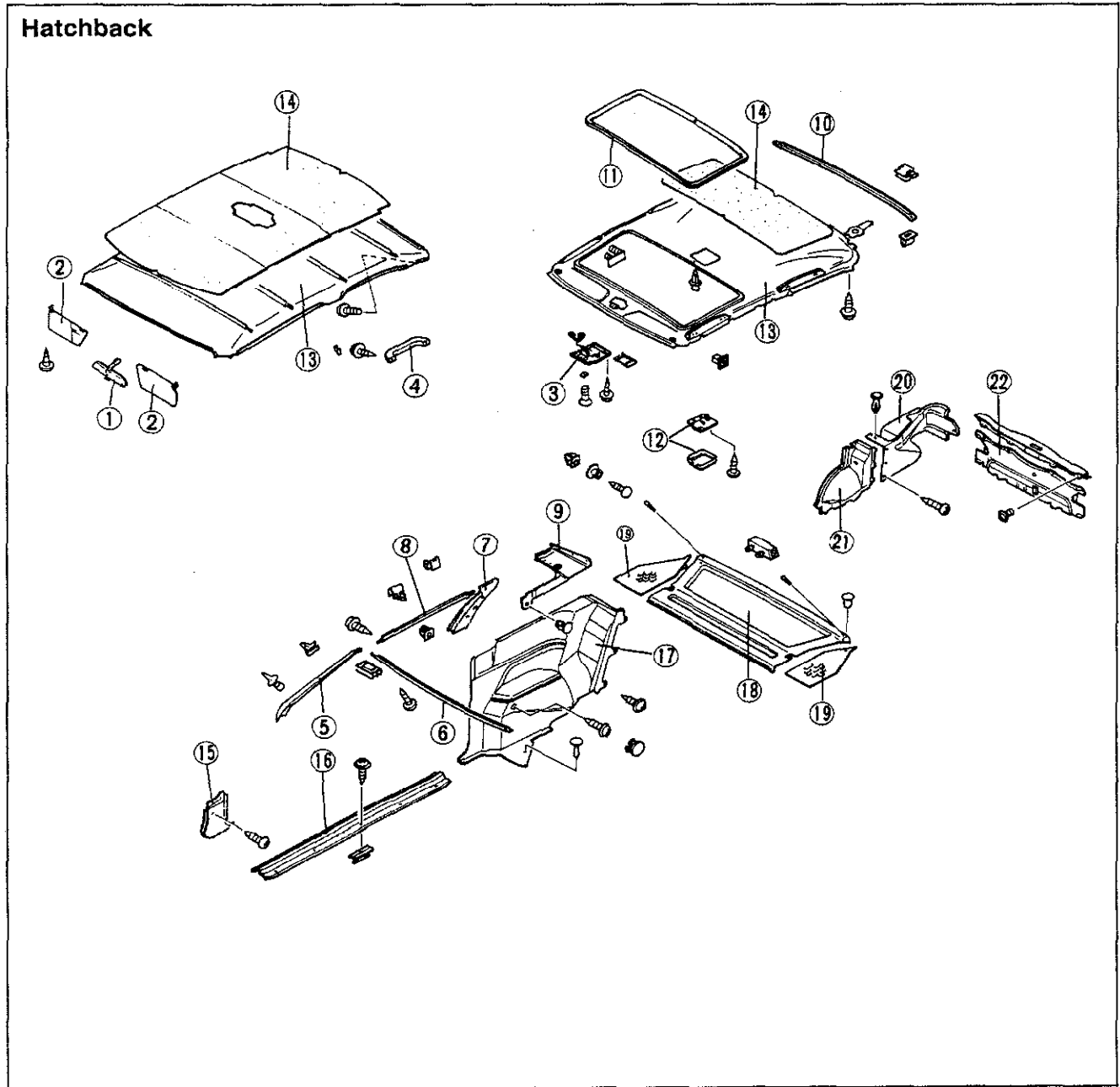

83U14X-032

- |                       |                       |                         |
|-----------------------|-----------------------|-------------------------|
| 1. Interior mirror    | 9. Rear pillar trim   | 17. Quarter trim        |
| 2. Sunvisor           | 10. Rear garnish      | 18. Package tray trim   |
| 3. Overhead console   | 11. Seaming welt      | 19. Package side shelf  |
| 4. Assist grip        | 12. Interior light    | 20. Trunk side trim     |
| 5. Front pillar trim  | 13. Head liner        | 21. Tire house trim     |
| 6. Front header trim  | 14. Insulation        | 22. Trunk room end trim |
| 7. Center pillar trim | 15. Front side trim   |                         |
| 8. Side garnish       | 16. Front scuff plate |                         |

# 14 HEAD LINER

Sedan

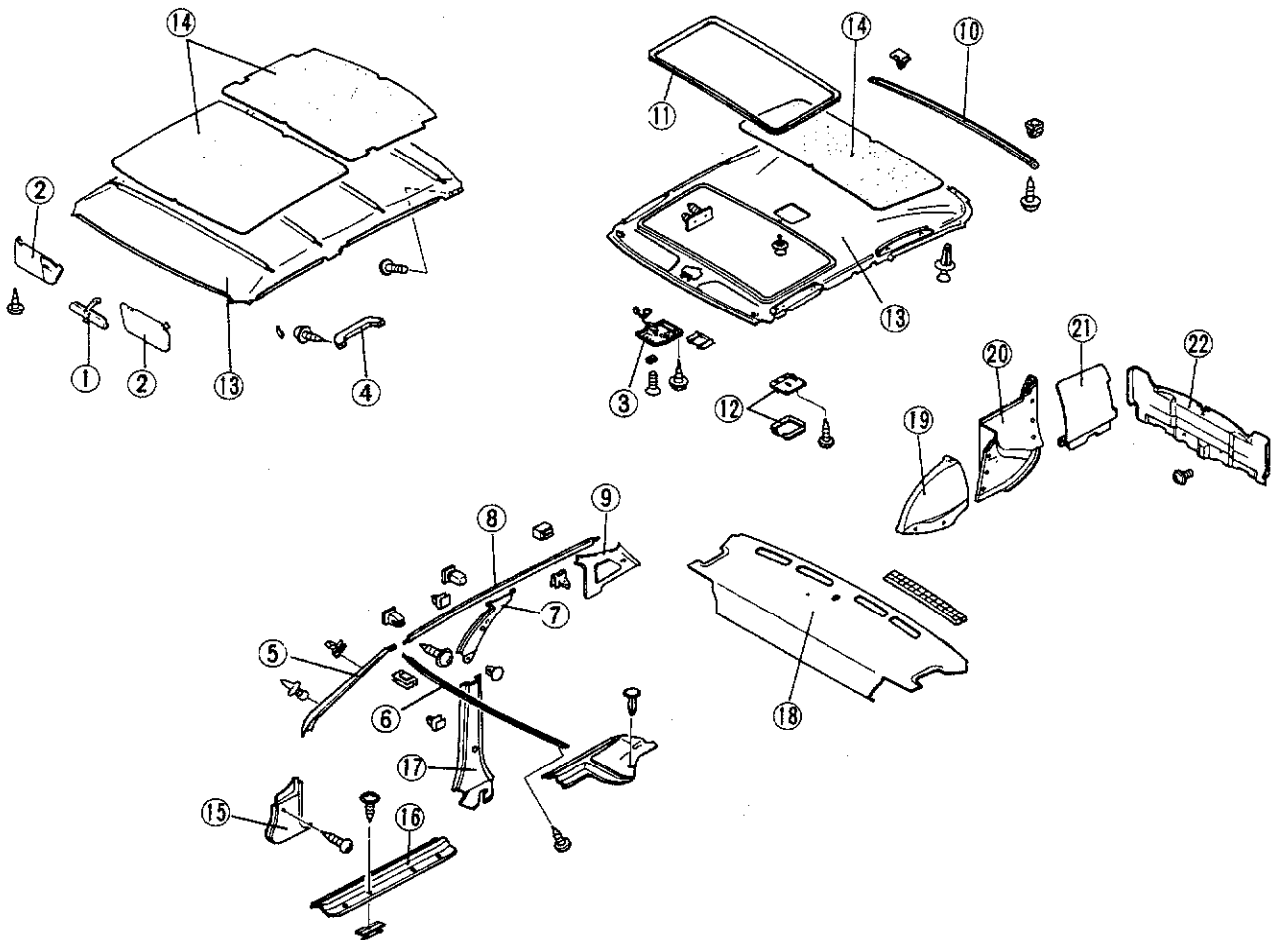

83U14X-033

- |                               |                       |                                |
|-------------------------------|-----------------------|--------------------------------|
| 1. Interior mirror            | 9. Rear pillar trim   | 17. Center pillar trim (lower) |
| 2. Sunvisor                   | 10. Rear garnish      | 18. Package tray trim          |
| 3. Overhead console           | 11. Seaming welt      | 19. Tire house trim            |
| 4. Assist grip                | 12. Interior light    | 20. Trunk room front trim      |
| 5. Front pillar trim          | 13. Head liner        | 21. Trunk room end trim        |
| 6. Front header trim          | 14. Insulation        | 22. Trunk side trim            |
| 7. Center pillar trim (upper) | 15. Front side trim   |                                |
| 8. Side garnish               | 16. Front scuff plate |                                |



## REMOVAL (VEHICLE WITHOUT SUNROOF)

1. Remove the interior mirror, sunvisors, sunvisor holders and the assist grips.

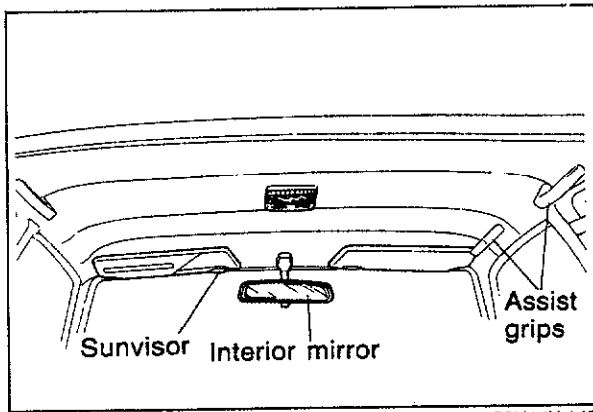

63U14X-149

2. Remove the lens of the interior light and remove the screws.  
 3. Disconnect the interior light connector.

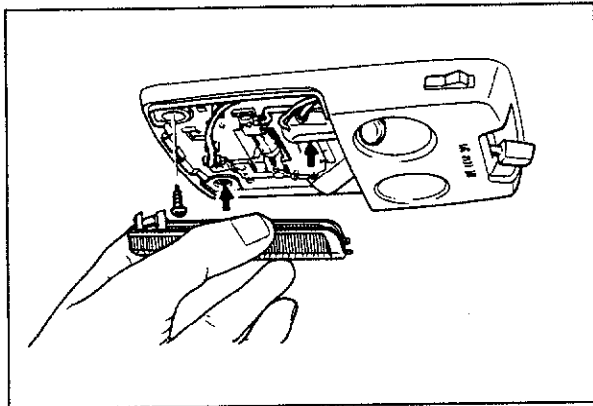

63U14X-150

4. Remove the hinge cover and the screws, then remove the side glass.  
 (3 door hatchback vehicle only)

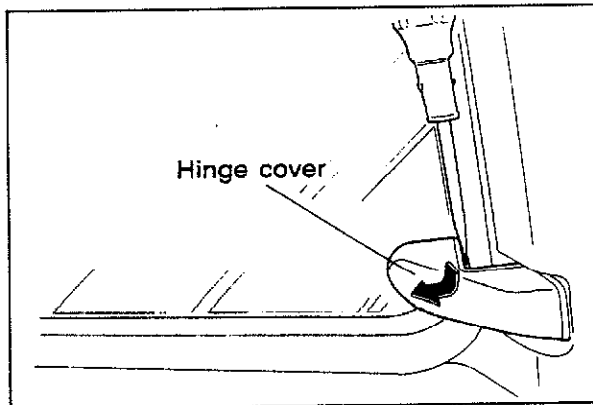

63U14X-151

5. Remove the weatherstrip.  
 6. Remove the seaming welt.

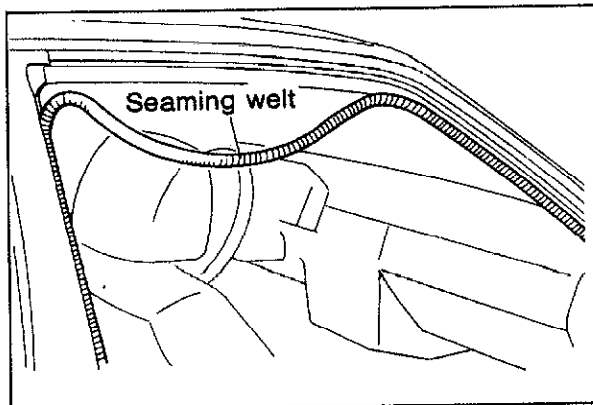

63U14X-152

# 14 HEAD LINER

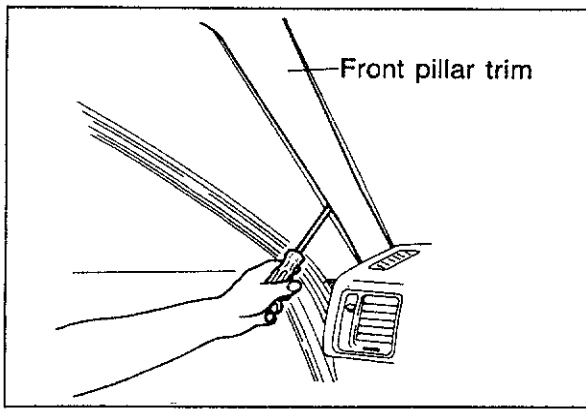

63U14X-153

7. Remove the front door trim by prying with a screwdriver.
8. Remove the center pillar trim.

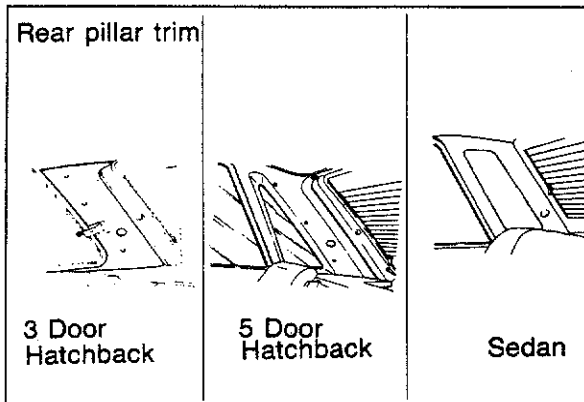

63U14X-154

9. Remove the weatherstrip, fasteners and then remove the rear pillar trim.

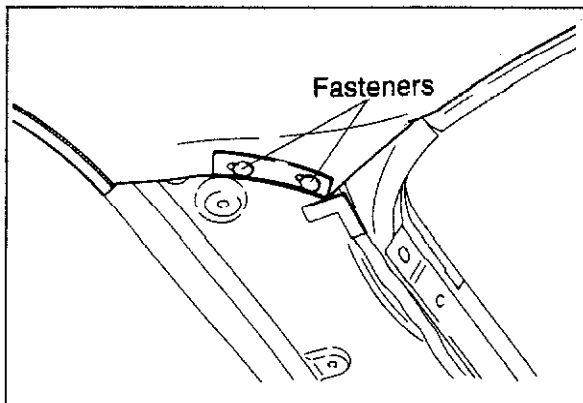

83U14X-034

10. Remove the fasteners from the head liner.

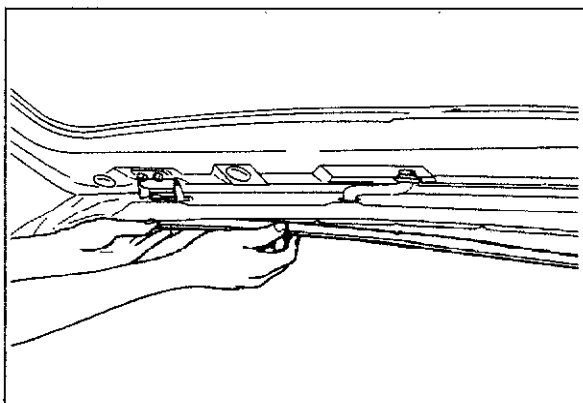

11. Remove the head liner rear end plate.

**Note**  
For a sedan vehicle, remove the plate while pushing the weatherstrip away from the end plate.

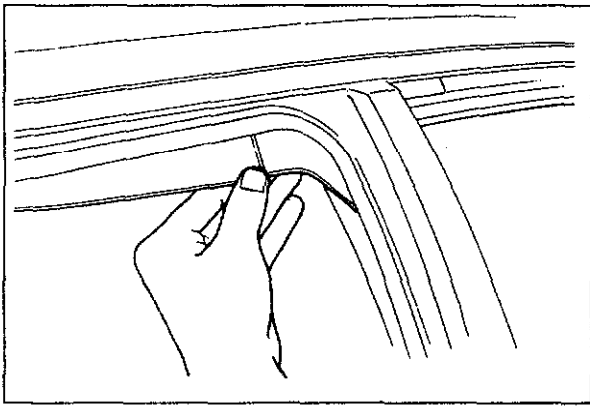

83U14X-036

12. Remove the rear of the head liner by pulling if free at the corners.

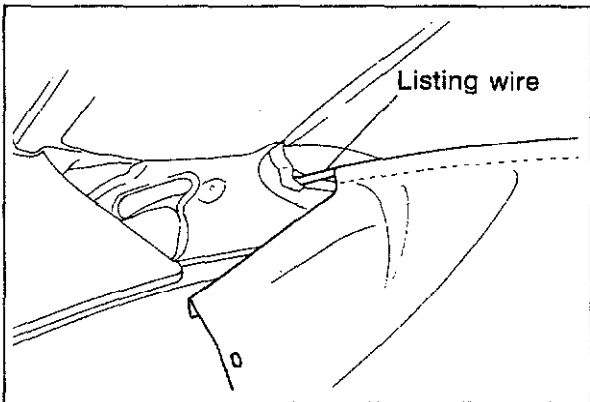

83U14X-037

13. Remove the listing wire forward.
14. Remove the front part of the head liner.

### INSTALLATION

Follow the reverse order of removal.

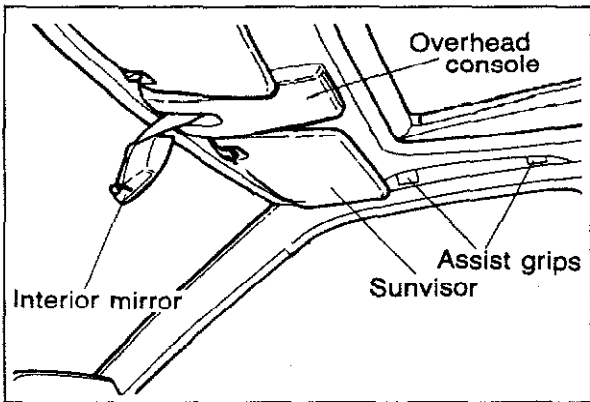

63U14X-159

### REMOVAL (VEHICLE WITH SUNROOF)

1. Remove the overhead console, interior mirror, sunvisors, sunvisor holders and the assist grips.

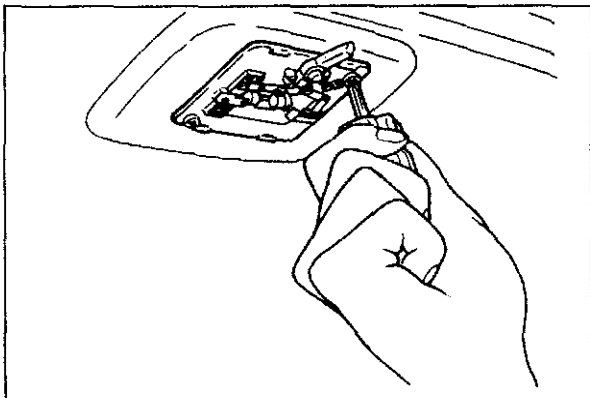

63U14X-160

2. Remove the lens of the interior light, and remove the screws.
3. Disconnect the harness connector, and remove the interior light.

# 14 HEAD LINER

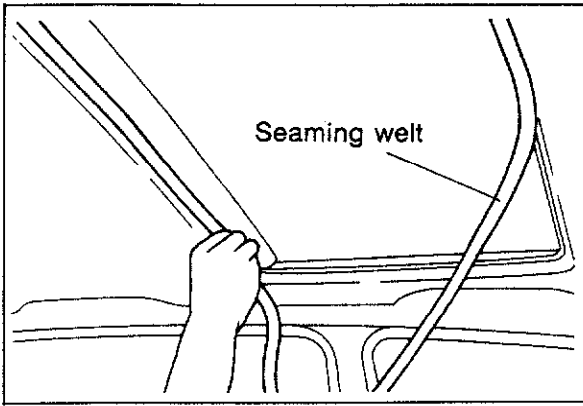

63U14X-161

4. Remove the seaming welt from the sunroof opening.

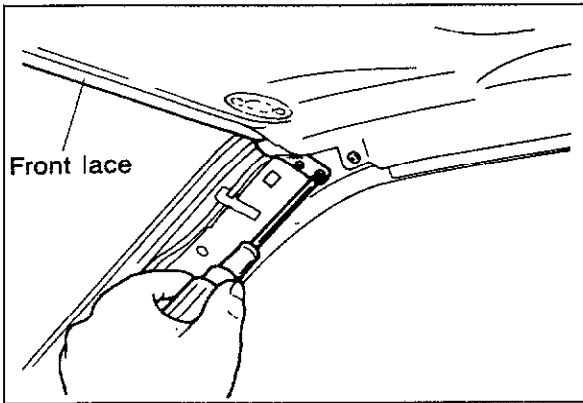

83U14X-038

5. Remove the front of the door opening seaming welts.
6. Remove the front pillar trims.
7. Remove the head liner front lace.

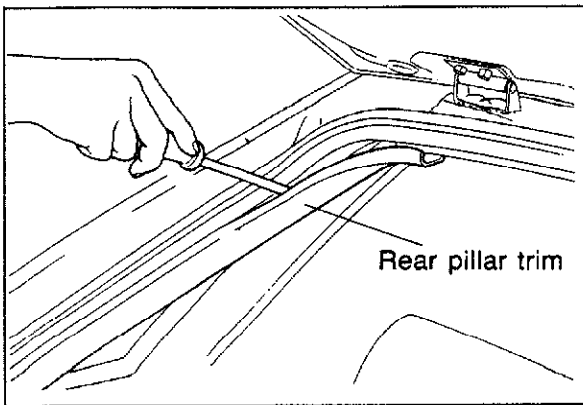

83U14X-039

8. Remove the rear of the door opening seaming welts.
9. Remove the rear pillar trim.
10. Remove the head liner rear lace.

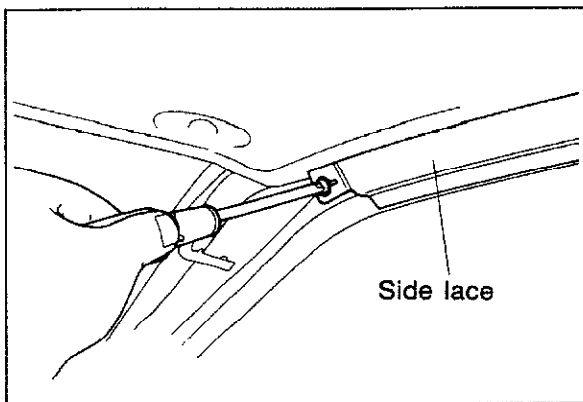

83U14X-040

11. Remove the side pillar trim.
12. Remove the attaching screws of the head liner side lace and remove the side lace.

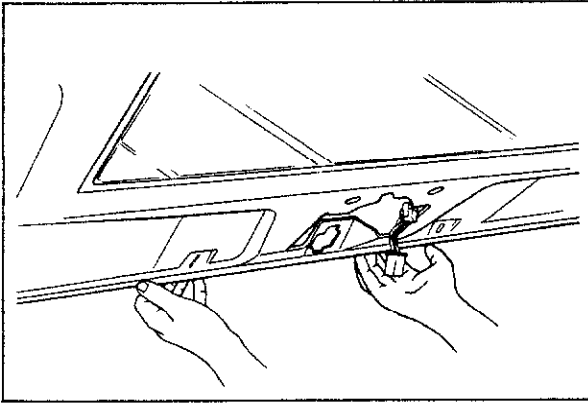

83U14X-041

13. Remove the fasteners at side of the head liner and remove the head liner.

## INSTALLATION

Follow the reverse order of removal.

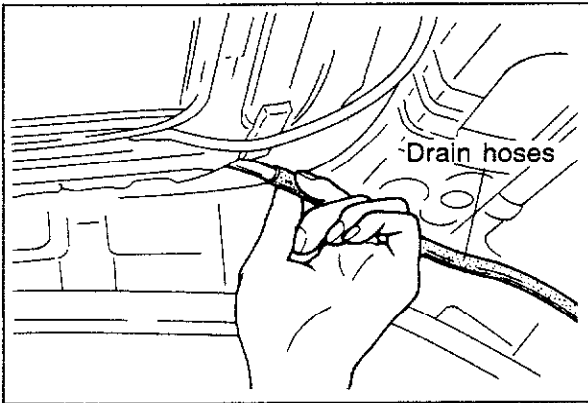

83U14X-019

## FRAME ASSEMBLY OF SLIDING SUNROOF

### REMOVAL

1. Remove the head liner.
2. Disconnect the drain hoses (4) from the frame assembly.
3. Remove the interior light harness.

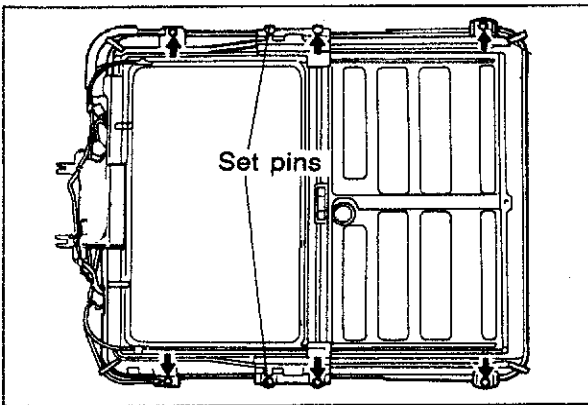

83U14X-042

4. Remove the set bracket attaching bolts.
5. Lower the sunroof frame assembly slowly and remove it.

### INSTALLATION

Follow the reverse order of removal.

#### Tightening torque:

**Set bracket attaching bolt**

**8.8—12.8 N·m**

**(0.9—1.3 m·kg, 6.5—9.4 ft·lb)**

#### Note

When installing the frame assembly, set the set holes of the frame assembly to the set pins of the body roof, and then install the set bracket attaching bolts.

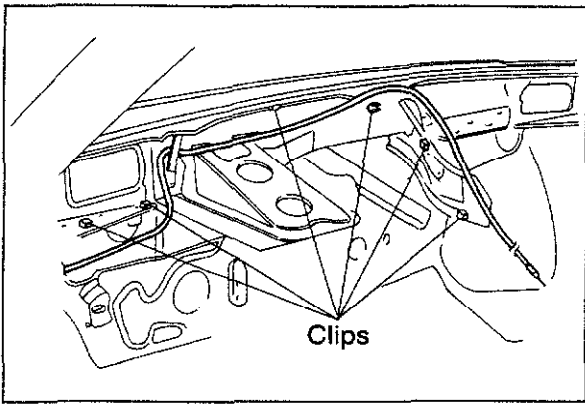

63U14X-169

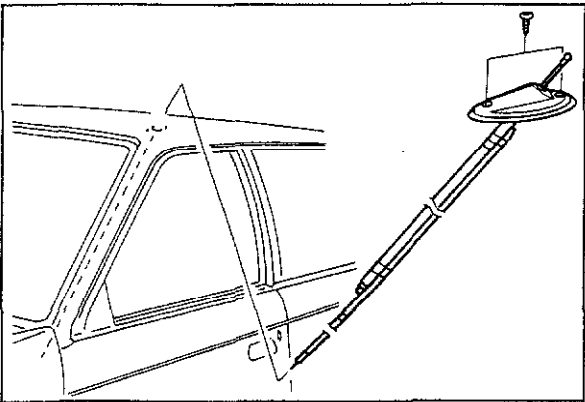

63U14X-170

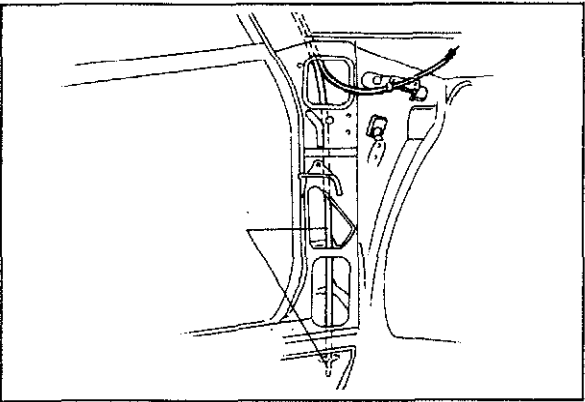

63U14X-171

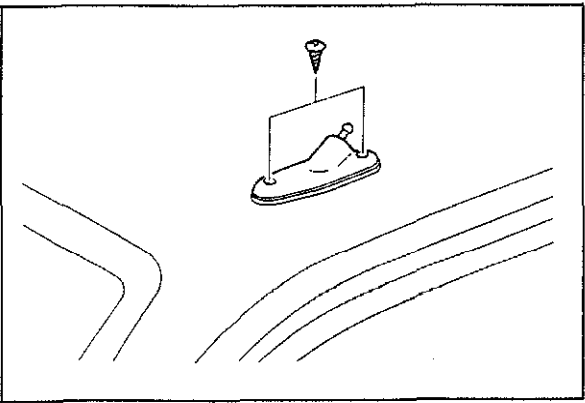

63U14X-172

## ANTENNA FEEDER

### REMOVAL

1. Remove the instrument panel
2. Remove the kick panel.
3. Detach the antenna feeder from the clips.

4. Remove the attaching screws, and then pull out the antenna assembly.  
(The sunroof drain pipe will come out with it.)

### INSTALLATION

1. Install the antenna feeder and the sunroof drain pipe into the front pillar.
2. Attach the antenna feeder to the clips.

3. Fix the antenna base.

FRONT BODY DIMENSIONS

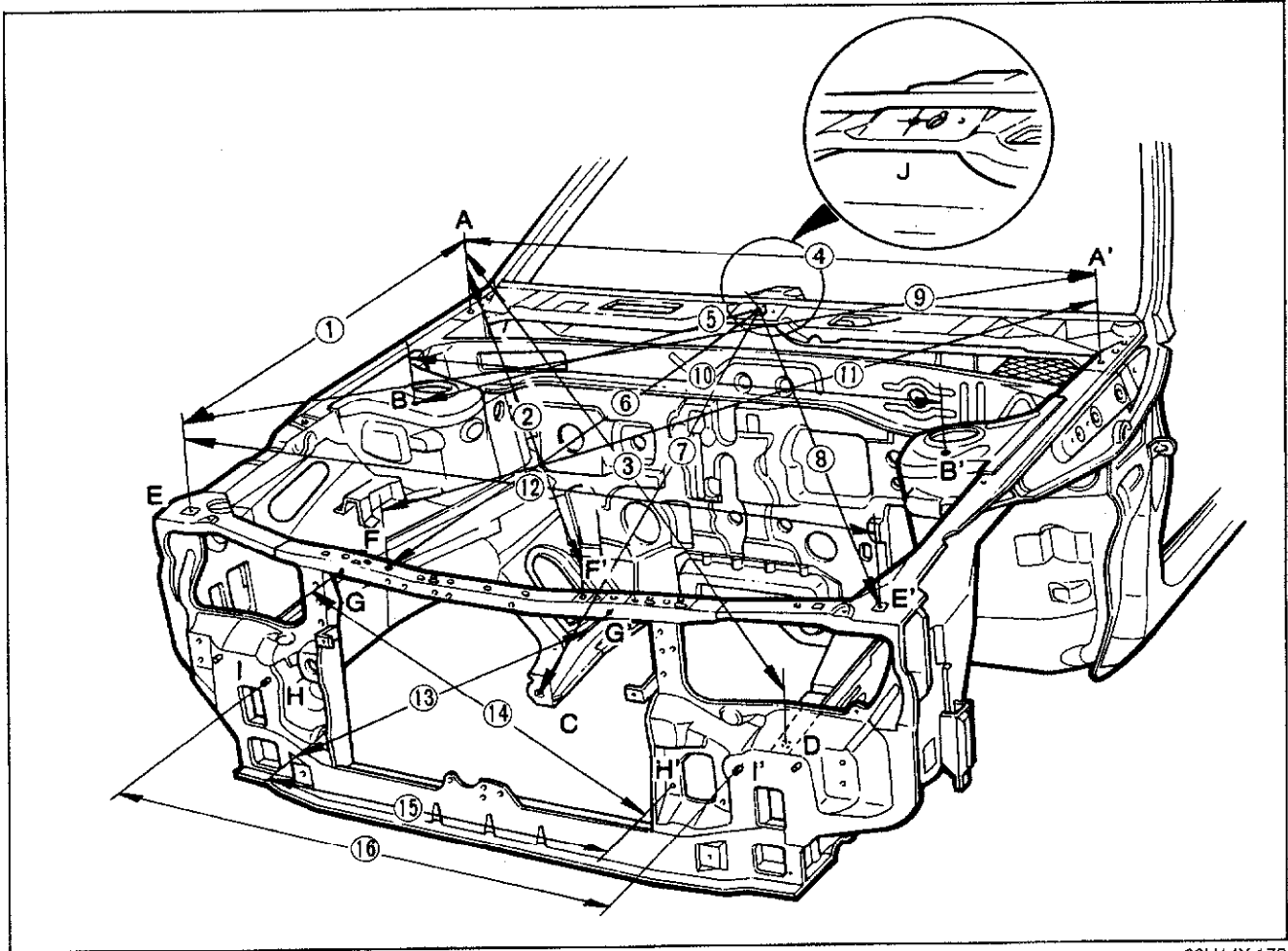

63U14X-173

- A, A' : Front fender mounting nut
- B, B' : Front suspension mounting block mounting hole
- C : Front lower arm attaching nut
- D : Ground mounting nut
- E, E' : Front fender mounting nut
- F, F' : Wiring harness clip mounting hole
- G, G' : Condenser mounting nut
- H, H' : Front skirt mounting nut
- I, I' : Front bumper mounting nut
- J : Wiper mounting nut

Measurement	Length mm (in)	
	Right side	Left side
1	817 (32.17)	817 (32.17)
2	1,208 (47.56)	1,211 (47.68)
3	1,408 (55.43)	1,416 (55.75)
4	1,303 (51.30)	—
5	655 (25.79)	671 (26.42)
6	960 (37.80)	962 (37.87)
7	874 (34.41)	882 (34.72)
8	1,083 (42.64)	1,095 (43.11)
9	1,525 (60.04)	1,525 (60.04)
10	1,067 (42.01)	—
11	1,208 (47.56)	1,211 (47.68)
12	1,273 (50.12)	—
13	621 (24.45)	—
14	645 (25.39)	—
15	640 (25.20)	—
16	894 (35.20)	—

# 14 UNDERBODY PROJECTED DIMENSIONS

## UNDERBODY PROJECTED DIMENSIONS

5 Door Hatchback  
3 Door Hatchback (Except 4WD)

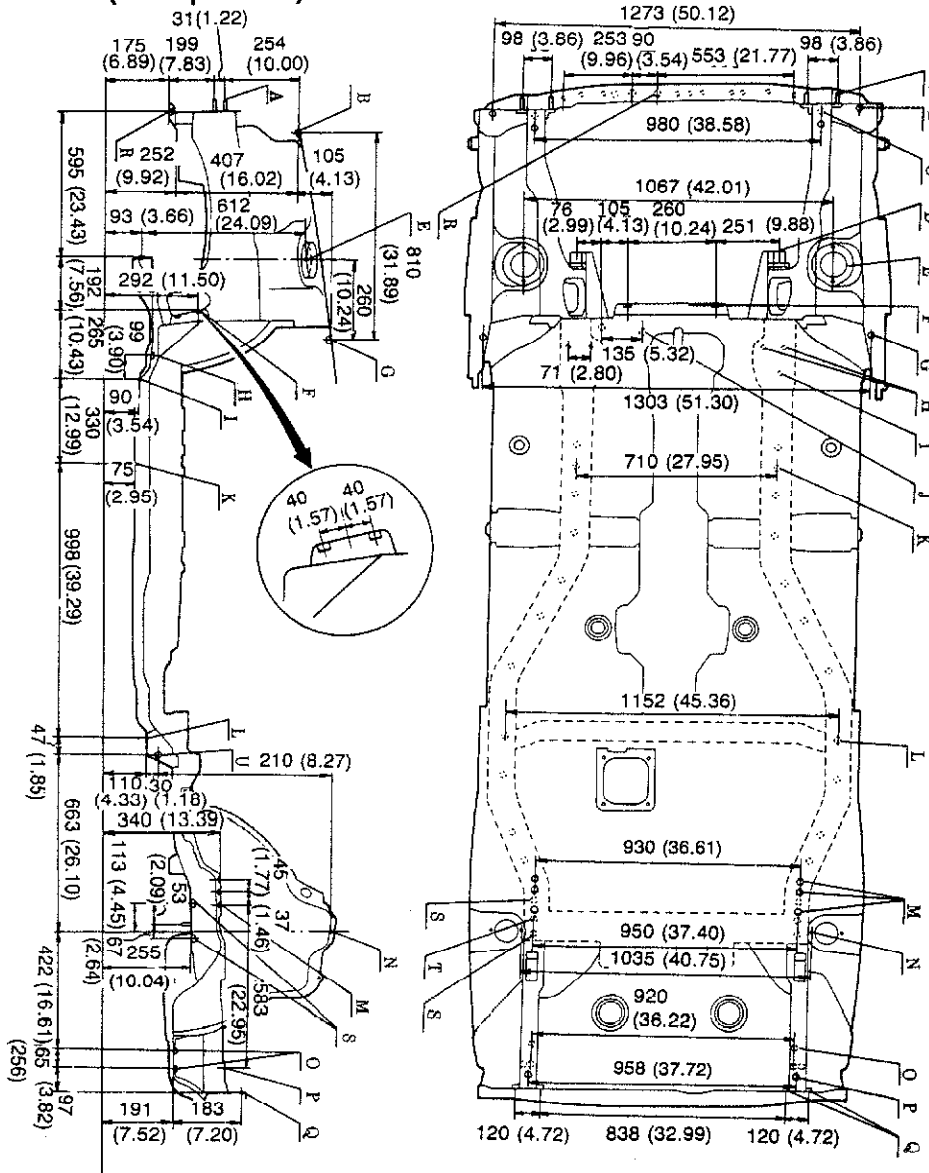

mm (in)

63U14X-174

- |   |   |
|---|---|
| A: Front bumper mounting nut                        | L: Parking brake cable mounting nut             |
| B: Front fender mounting nut                        | M: Rear seat back hinge mounting nut            |
| C: Front frame reference hole                       | N: Rear suspension mounting block mounting hole |
| D: Front lower arm reference hole                   | O: Hook mounting nut                            |
| E: Front suspension mounting block mounting surface | P: Rear frame reference hole                    |
| F: Steering bracket mounting nut                    | Q: Rear bumper mounting hole                    |
| G: Front fender mounting nut                        | R: Engine member mounting nut                   |
| H: Front lower arm mounting nut                     | S: Rear crossmember mounting nut                |
| I: Front frame lower reference hole                 | T: Rear crossmember reference bolt              |
| J: Engine member mounting nut                       | U: Trailing link mounting nut                   |
| K: Front frame reference hole                       |   |



**3 Door Hatchback (4WD)**

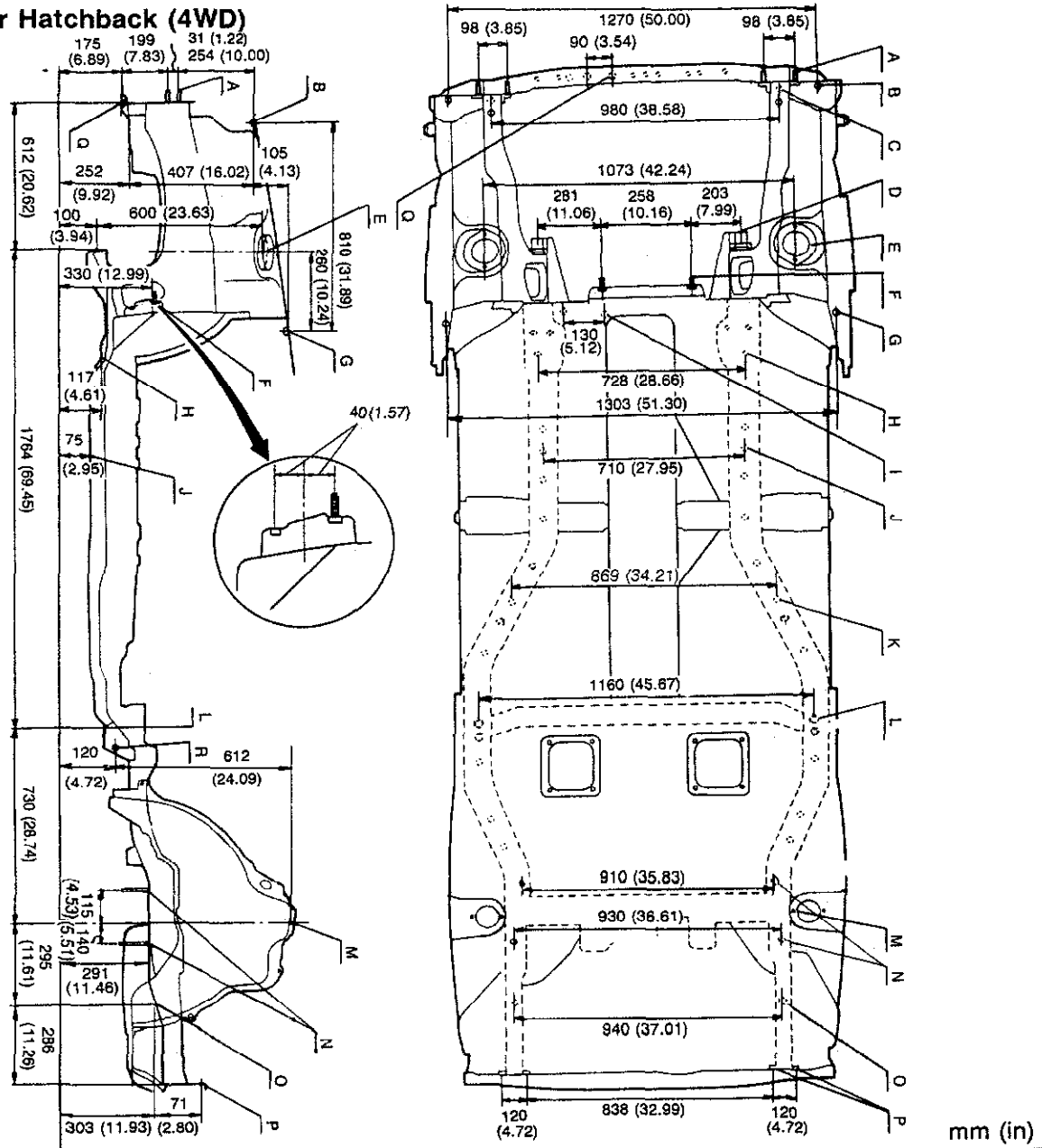

mm (in)

83U14X-017

- A: Front bumper mounting nut
- B: Front fender mounting nut
- C: Front frame reference hole
- D: Front lower arm reference hole
- E: Front suspension mounting block mounting surface
- F: Steering bracket mounting nut
- G: Front fender mounting nut
- H: Front frame lower reference hole
- I: Engine member mounting nut
- J: Front frame reference hole
- K: Front frame reference hole
- L: Trailing link mounting bracket reference hole
- M: Rear suspension mounting block mounting hole
- N: Rear crossmember mounting bolt
- O: Rear frame reference hole
- P: Rear bumper mounting hole
- Q: Engine member mounting nut
- R: Rear crossmember mounting nut

# 14 UNDERBODY PROJECTED DIMENSIONS

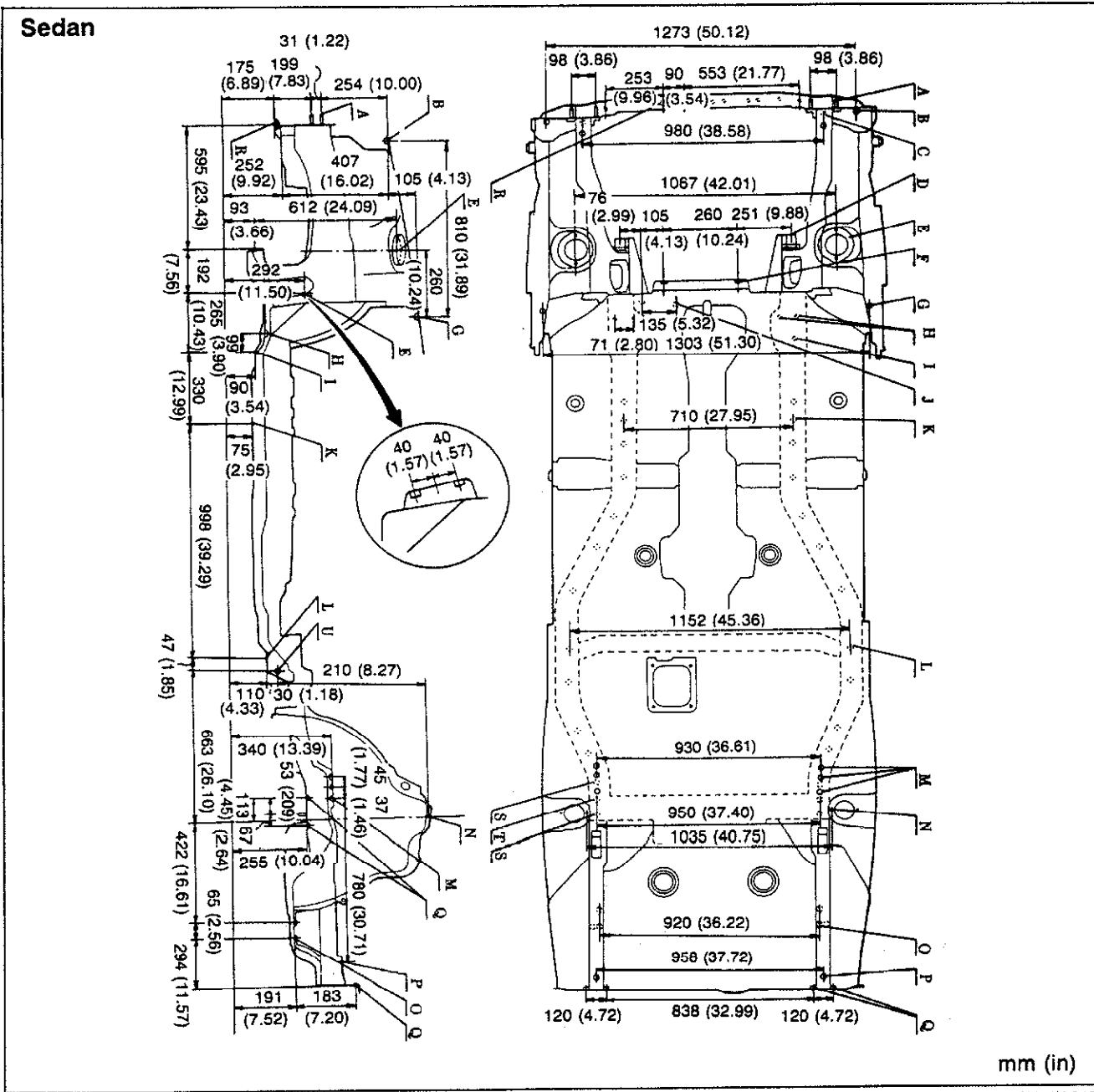

83U14X-043

- |   |   |
|---|---|
| <ul style="list-style-type: none"> <li>A: Front bumper mounting nut</li> <li>B: Front fender mounting nut</li> <li>C: Front frame reference hole</li> <li>D: Front lower arm reference hole</li> <li>E: Front suspension mounting block mounting surface</li> <li>F: Steering bracket mounting nut</li> <li>G: Front fender mounting nut</li> <li>H: Front lower arm mounting nut</li> <li>I: Front frame lower reference hole</li> <li>J: Engine member mounting nut</li> <li>K: Front frame reference hole</li> </ul> | <ul style="list-style-type: none"> <li>L: Parking brake cable mounting nut</li> <li>M: Rear seatback hinge mounting nut</li> <li>N: Rear suspension mounting block mounting hole</li> <li>O: Hook mounting nut</li> <li>P: Rear frame reference hole</li> <li>Q: Rear bumper mounting hole</li> <li>R: Engine member mounting nut</li> <li>S: Rear crossmember mounting nut</li> <li>T: Rear crossmember reference bolt</li> <li>U: Trailing link mounting nut</li> </ul> |
|---|---|

**UNDERBODY STRAIGHT-LINE DIMENSIONS**

5 Door Hatchback  
3 Door Hatchback (Except 4WD)

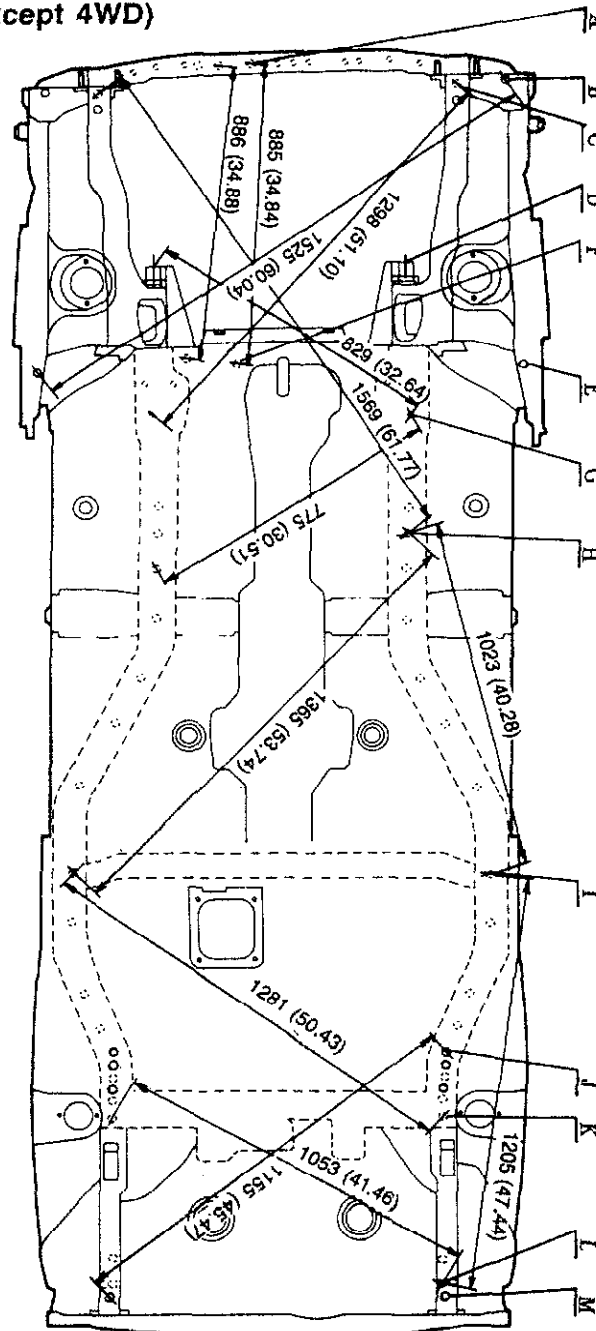

mm (in)

63U14X-176

- |                                     |                                      |
|-------------------------------------|--------------------------------------|
| A: Engine member mounting nut       | H: Front frame reference hole        |
| B: Front fender mounting nut        | I: Parking brake cable mounting nut  |
| C: Front frame reference hole       | J: Rear seat back hinge mounting nut |
| D: Front lower arm reference hole   | K: Rear crossmember mounting nut     |
| E: Front fender mounting nut        | L: Hook mounting nut                 |
| F: Engine member mounting nut       | M: Rear frame reference hole         |
| G: Front frame lower reference hole |                                      |

# 14 UNDERBODY STRAIGHT-LINE DIMENSIONS

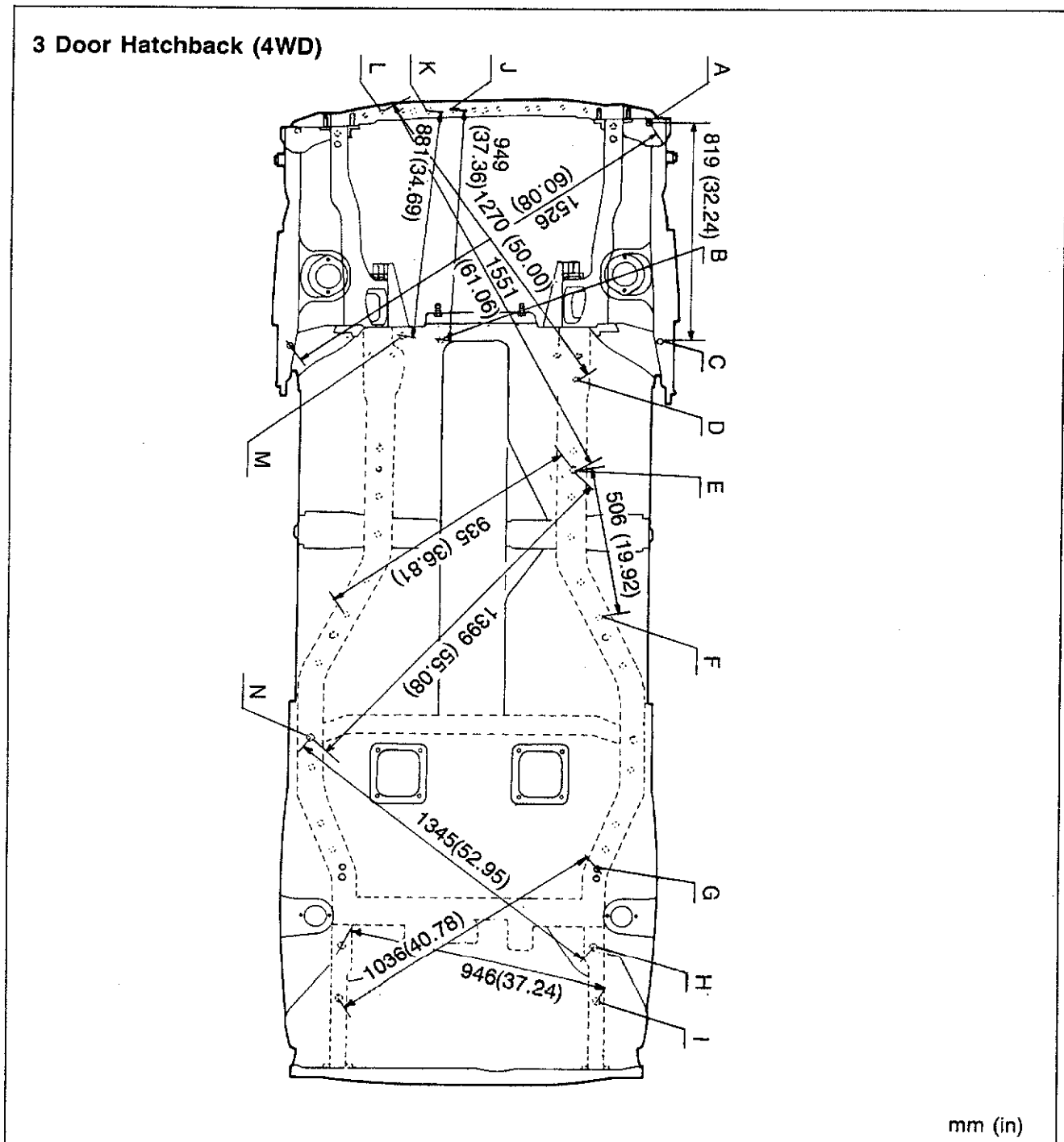

83U14X-018

- A: Front fender mounting nut
- B: Engine member mounting nut
- C: Front fender mounting nut
- D: Front frame lower reference hole
- E: Front frame reference hole
- F: Front frame reference hole
- G: Rear seat back hinge mounting nut

- H: Rear crossmember mounting bolt
- I: Rear frame reference hole
- J: Engine member mounting nut
- K: Engine member mounting nut
- L: Front stabilizer mounting nut
- M: Engine member mounting nut
- N: Parking brake cable mounting nut

**Sedan**

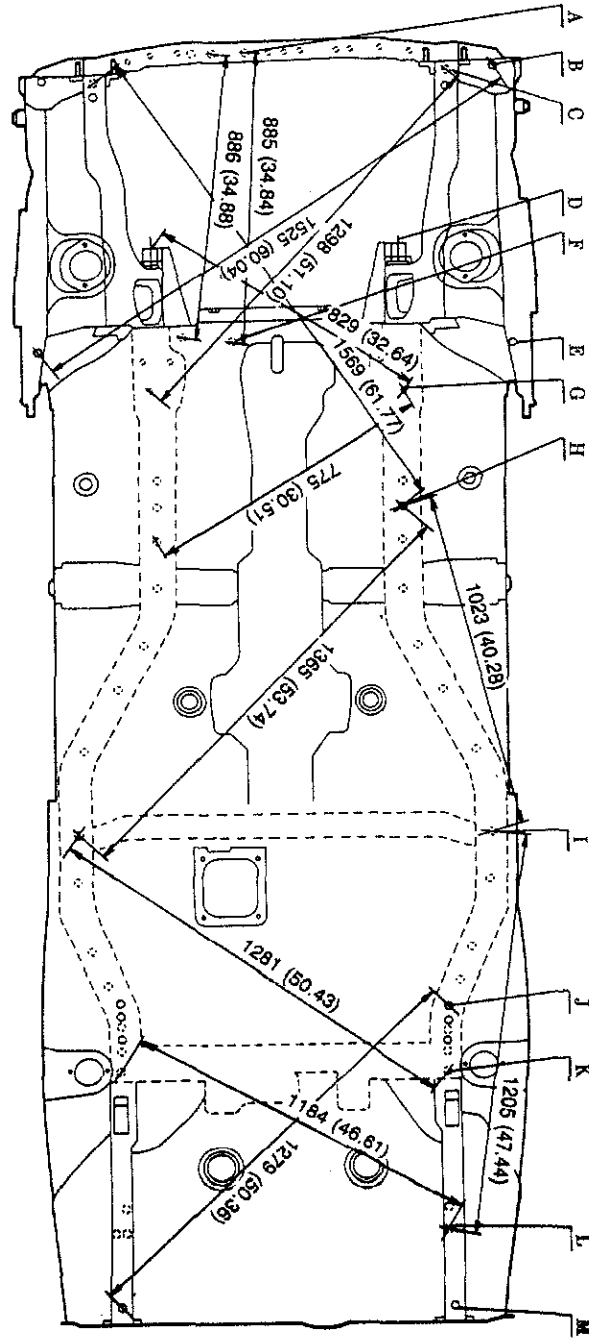

mm (in)

83U14X-044

- A: Engine member mounting nut
- B: Front fender mounting nut
- C: Front frame reference hole
- D: Front lower arm reference hole
- E: Front fender mounting nut
- F: Engine member mounting nut
- G: Front frame lower reference hole

- H: Front frame reference hole
- I: Parking brake cable mounting nut
- J: Rear seat back hinge mounting nut
- K: Rear crossmember mounting nut
- L: Hook mounting nut
- M: Rear frame reference hole

# BODY ELECTRICAL SYSTEM

<b>INTRODUCTION</b> .....	15—	3	<b>TURN AND HAZARD SIGNAL LIGHT</b>	15—	44
HOW TO USE THIS SECTION .....	15—	3	STRUCTURAL VIEW .....	15—	44
ELECTRICAL TROUBLESHOOTING			CIRCUIT DIAGRAM .....	15—	45
TOOLS .....	15—	3	TROUBLESHOOTING.....	15—	46
PRECAUTION.....	15—	4	FLASHER UNIT .....	15—	48
ELECTRICAL SYMBOL.....	15—	7	<b>ILLUMINATED ENTRY SYSTEM</b> ....	15—	49
<b>MAIN FUSE AND JOINT BOX</b> .....	15—	8	STRUCTURAL VIEW .....	15—	49
STRUCTURAL VIEW .....	15—	8	CIRCUIT DIAGRAM .....	15—	50
<b>SWITCHES, RELAYS AND UNITS</b> .	15—	9	TROUBLESHOOTING.....	15—	51
STRUCTURAL VIEW .....	15—	9	TIMER UNIT.....	15—	54
<b>IGNITION KEY SWITCH</b> .....	15—	13	<b>HORN</b> .....	15—	55
INSPECTION .....	15—	13	STRUCTURAL VIEW .....	15—	55
REPLACE .....	15—	13	CIRCUIT DIAGRAM .....	15—	56
<b>CIRCUIT BREAKER</b> .....	15—	13	TROUBLESHOOTING.....	15—	57
<b>COMBINATION SWITCH</b> .....	15—	14	INSPECTION .....	15—	58
STRUCTURAL VIEW .....	15—	14	<b>HEADLIGHT</b> .....	15—	59
INSPECTION .....	15—	14	CIRCUIT DIAGRAM .....	15—	59
INTERMITTENT WIPER UNIT .....	15—	16	TROUBLESHOOTING.....	15—	60
<b>CLUSTER SWITCH</b> .....	15—	17	<b>REAR WINDOW WIPER</b> .....	15—	61
STRUCTURAL VIEW .....	15—	17	STRUCTURAL VIEW .....	15—	61
INSPECTION .....	15—	18	CIRCUIT DIAGRAM .....	15—	62
DISASSEMBLY & ASSEMBLY.....	15—	19	TROUBLESHOOTING.....	15—	63
<b>METER (INCL. SENDER UNITS)</b> ....	15—	20	OPERATION CHECK OF REAR		
STRUCTURAL VIEW .....	15—	20	WIPER MOTOR .....	15—	66
DISASSEMBLY AND ASSEMBLY .	15—	21	<b>WINDSHIELD WIPER</b> .....	15—	67
TROUBLESHOOTING GUIDE .....	15—	22	STRUCTURAL VIEW .....	15—	67
ON-VEHICLE INSPECTION .....	15—	22	CIRCUIT DIAGRAM .....	15—	68
METER PRINTED CIRCUIT BOARD			TROUBLESHOOTING.....	15—	69
INSPECTION.....	15—	26	WIPER MOTOR.....	15—	73
TROUBLESHOOTING.....	15—	27	WASHER MOTOR .....	15—	73
INSPECTION OF CIRCUIT AND			<b>POWER DOOR LOCK</b> .....	15—	74
PARTS.....	15—	31	STRUCTURAL VIEW .....	15—	74
STOP LIGHT CHECKER .....	15—	32	CIRCUIT DIAGRAM .....	15—	75
<b>LIGHTS REMINDER WARNING</b> .....	15—	35	TROUBLESHOOTING.....	15—	76
STRUCTURAL VIEW .....	15—	35	INSPECTION .....	15—	77
CIRCUIT DIAGRAM .....	15—	36	<b>POWER WINDOW</b> .....	15—	78
TROUBLESHOOTING.....	15—	37	STRUCTURAL VIEW .....	15—	78
OSCILLATOR UNIT .....	15—	38	CIRCUIT DIAGRAM .....	15—	79
<b>STOP LIGHT</b> .....	15—	39	TROUBLESHOOTING.....	15—	80
STRUCTURAL VIEW .....	15—	39	INSPECTION .....	15—	83
CIRCUIT DIAGRAM .....	15—	40	<b>REMOTE CONTROL MIRROR</b> .....	15—	84
TROUBLESHOOTING.....	15—	41	STRUCTURAL VIEW .....	15—	84
STOP LIGHT CHECKER .....	15—	42	CIRCUIT DIAGRAM .....	15—	85
STOP LIGHT SWITCH .....	15—	43	TROUBLESHOOTING.....	15—	86

<b>ADJUSTABLE SHOCK</b>	
<b>ABSORBER</b> .....	15— 87
STRUCTURAL VIEW .....	15— 87
CIRCUIT DIAGRAM .....	15— 88
TROUBLESHOOTING.....	15— 89
INSPECTION .....	15— 90
<b>CRUISE CONTROL SYSTEM</b> .....	15— 92
STRUCTURAL VIEW .....	15— 92
TROUBLESHOOTING GUIDE .....	15— 93
ON-VEHICLE INSPECTION (USING ACC CHECKER).....	15— 94
CRUISE CONTROL UNIT.....	15— 97
CLUTCH SWITCH, BRAKE SWITCH	15— 98
<b>CENTER DIFFERENTIAL LOCK</b>	
<b>SYSTEM</b> .....	15— 99
STRUCTURAL VIEW .....	15— 99
CIRCUIT DIAGRAM .....	15— 99
CENTER DIFFERENTIAL LOCK CONTROL SWITCH.....	15—100
CENTER DIFFERENTIAL LOCK MOTOR .....	15—101
CENTER DIFFERENTIAL LOCK SENSOR SWITCH.....	15—104

<b>REAR WINDOW DEFROSTER</b> .....	15—105
STRUCTURAL VIEW .....	15—105
CIRCUIT DIAGRAM .....	15—106
TROUBLESHOOTING.....	15—107
INSPECTION .....	15—108
<b>HEATER</b> .....	15—109
STRUCTURAL VIEW .....	15—109
HEATER CONTROL SWITCH .....	15—113
ADJUSTMENTS .....	15—113
BLOWER UNIT REMOVAL.....	15—114
BLOWER CONTROL RESISTOR...	15—115
<b>AUDIO SYSTEM</b> .....	15—116
OUTLINE OF AUDIO SYSTEM.....	15—116
REAR VIEW AND CONNECTORS	15—117
TROUBLESHOOTING.....	15—118
INSTALLATION .....	15—126

## INTRODUCTION

### HOW TO USE THIS SECTION

Information regarding removal and installation of electrical equipment is given in **SECTION 14**. Understanding will be easier if this section is used in conjunction with the **WIRING DIAGRAMS**.

63U15X-002

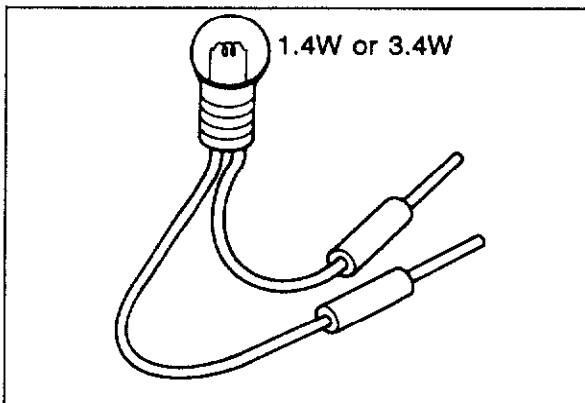

63U15X-003

### ELECTRICAL TROUBLESHOOTING TOOLS

#### Test Light

The test light, as shown in the figure, uses a 12-V bulb. The two lead wires should be connected to probes. The test light is used for simple voltage checks and to check for short circuits.

#### Caution

**When checking the control unit, never use a bulb over 3.4 W.**

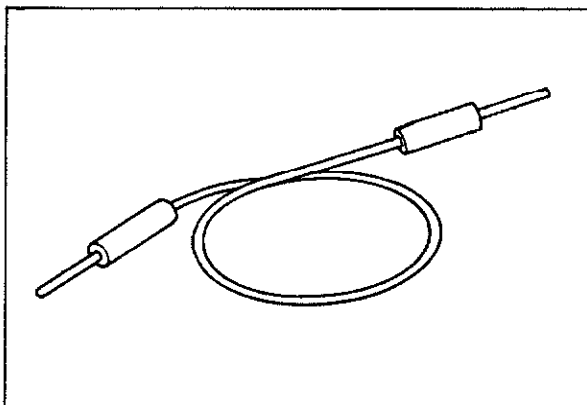

63G15X-002

#### Jumper Wire

The jumper wire is used for testing by short-circuiting switch terminals and to verify the condition of ground connections.

#### Caution

**Do not connect the jumper wire between the power source line and the body ground, because doing so may cause burning or other damage to harnesses or electronic components etc.**

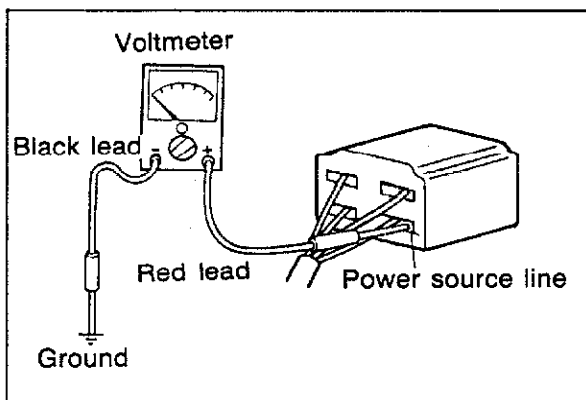

47U15X-006

#### Voltmeter

The DC voltmeter is used for measurement of circuit voltage. A voltmeter with a range of 15 V or more is used. It is used by connecting the positive (+) probe (the red lead wire) to the point where voltage is to be measured and connecting the negative (-) probe (the black lead wire) to the body ground.



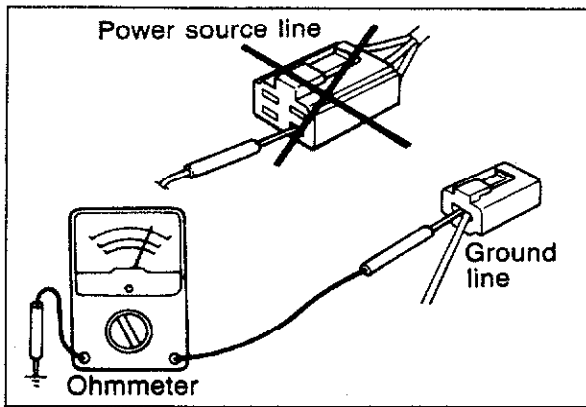

63U15X-005

## Ohmmeter

The ohmmeter is used to measure the resistance between two points in a circuit, and is also used to check for continuity and diagnosis of short circuits.

### Caution

**Do not attempt to connect the ohmmeter to any circuit to which voltage is applied, because doing so may burn or otherwise damage the ohmmeter.**

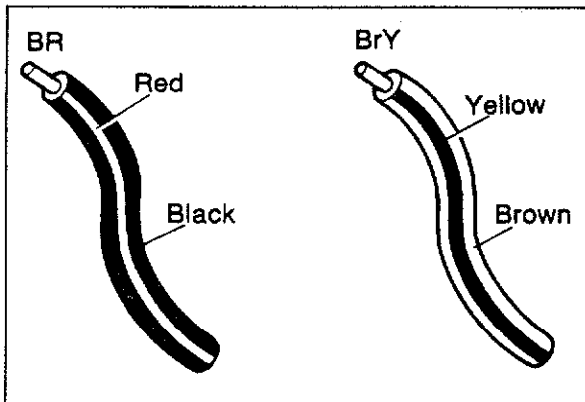

47U15X-008

## PRECAUTION

### Wiring Color Code

Two-color wires are indicated by a 2-letter symbol. The first letter indicates the base color of the wire and the second indicates the color of the stripe.

CODE	COLOR
B	BLACK
Br	BROWN
G	GREEN
L	BLUE
Lb	LIGHT BLUE
Lg	LIGHT GREEN
O	ORANGE
R	RED
Y	YELLOW
W	WHITE

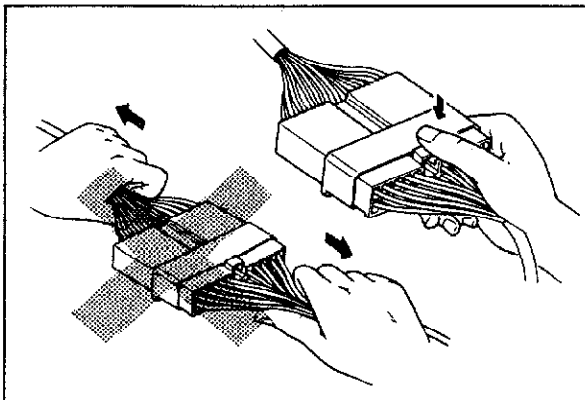

47U15X-009

## Bulkhead-Type Connector

The connector can be removed by pressing the lock lever.

Do not pull the wire when removing the connector; be careful to hold the connector itself when disconnecting.

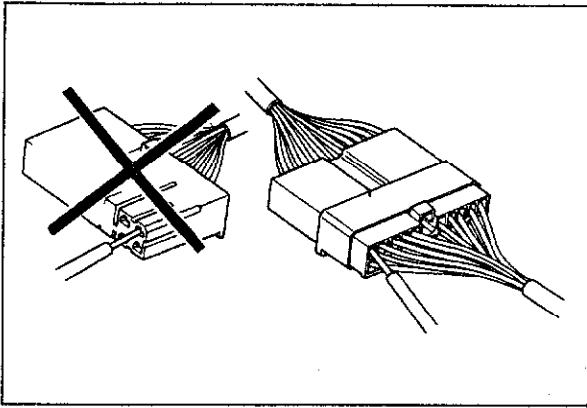

4EG15X-088

### Inspection note

When checking the continuity or voltage with a circuit tester, insertion of the test probe into the receptacle connector may open the fitting of the connector and result in poor contact.

Therefore, ensure that the test probe is inserted from the wire harness side.

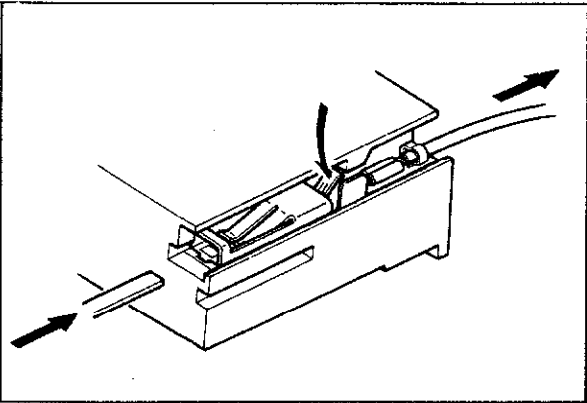

5BU15X-003

### Replacement of Terminal

Use the appropriate tools to remove the terminal, as shown in the figure.

When installing a terminal, be sure to press it in until it locks securely.

#### < Female Type No.1 >

Insert a push-tool or thin piece of metal from the terminal side of the connector, and then, with the locking tabs of the terminal pressed down, pull the terminal out from the rear side.

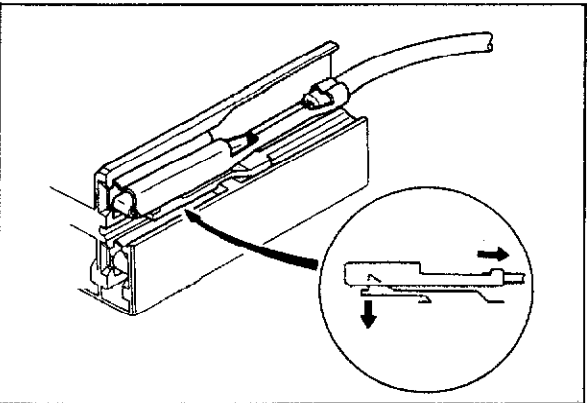

5BU15X-004

#### < Female Type No.2 >

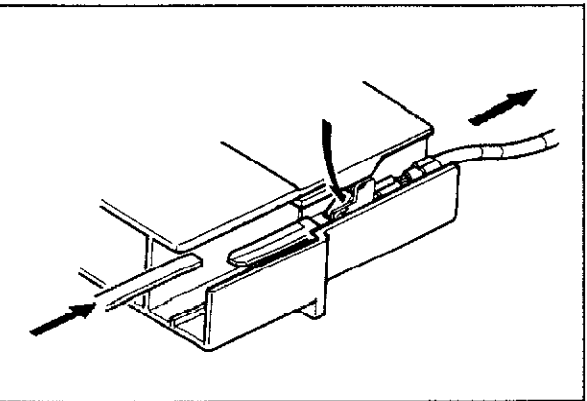

47U15X-012

#### < Male Type >

Same as the female type.

# 15 INTRODUCTION

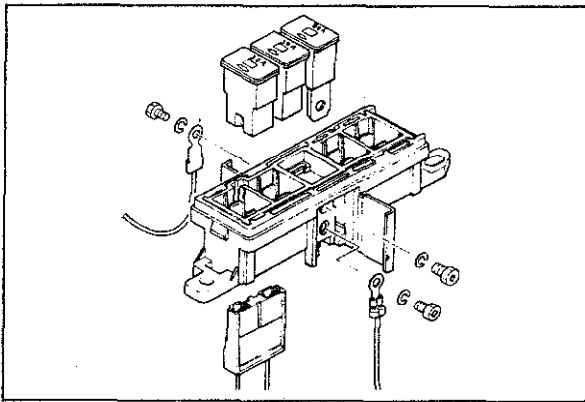

4BG15X-002

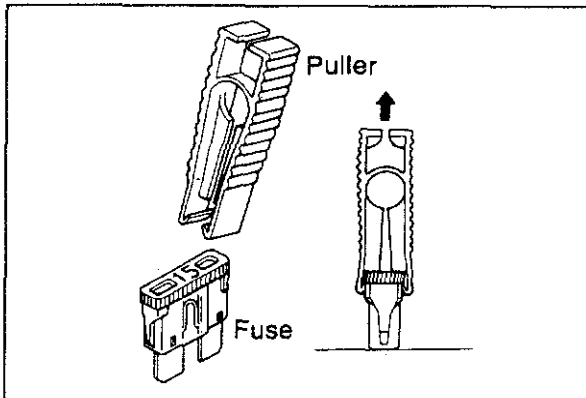

4BG15X-003

## Replacement of Fuse

1. When replacing a fuse, be sure to replace it with one of the specified capacity.  
If, after a fuse has been replaced, it fails again, there is probably a short circuit in the circuit, and the wiring should be checked.
2. Be sure the battery (—) terminal is disconnected before replacing a main fuse (80A).
3. When replacing a fuse, use the supplied fuse puller in the fuse box cover.







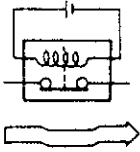
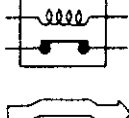
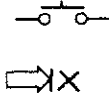
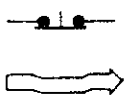
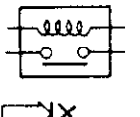
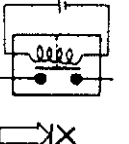
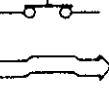
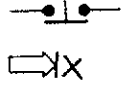



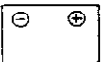

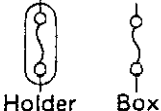
## ELECTRICAL SYMBOLS

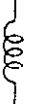
### Switches and Relays

There is an NC (normally closed) and NO (normally open) indication for switches and relays; this indicates when there has been no change of operation conditions.

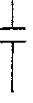
	Relay		Switch	
	NO type relay	NC type relay	NO switch	NC switch
Not in operation (No power supply)	 Stop	 Flow	 Stop	 Flow
In operation (Power supply)	 Flow	 Stop	 Flow	 Stop

### Other Electrical Symbols

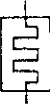
		 Holder    Box	
BATTERY	BODY GROUND	FUSIBLE	FUSIBLE LINK
			
MOTOR	COIL, SOLENOID	RESISTOR	VARIABLE RESISTOR
			
THERMISTER	DIODE	CONDENSER	LIGHT
			
TRANSISTOR	SPEAKER	CIGARETTE LIGHTER	HEATER

47U15X-013

# 15 MAIN FUSE AND JOINT BOX

## MAIN FUSE AND JOINT BOX (INCL. FUSE BOX)

### STRUCTURAL VIEW

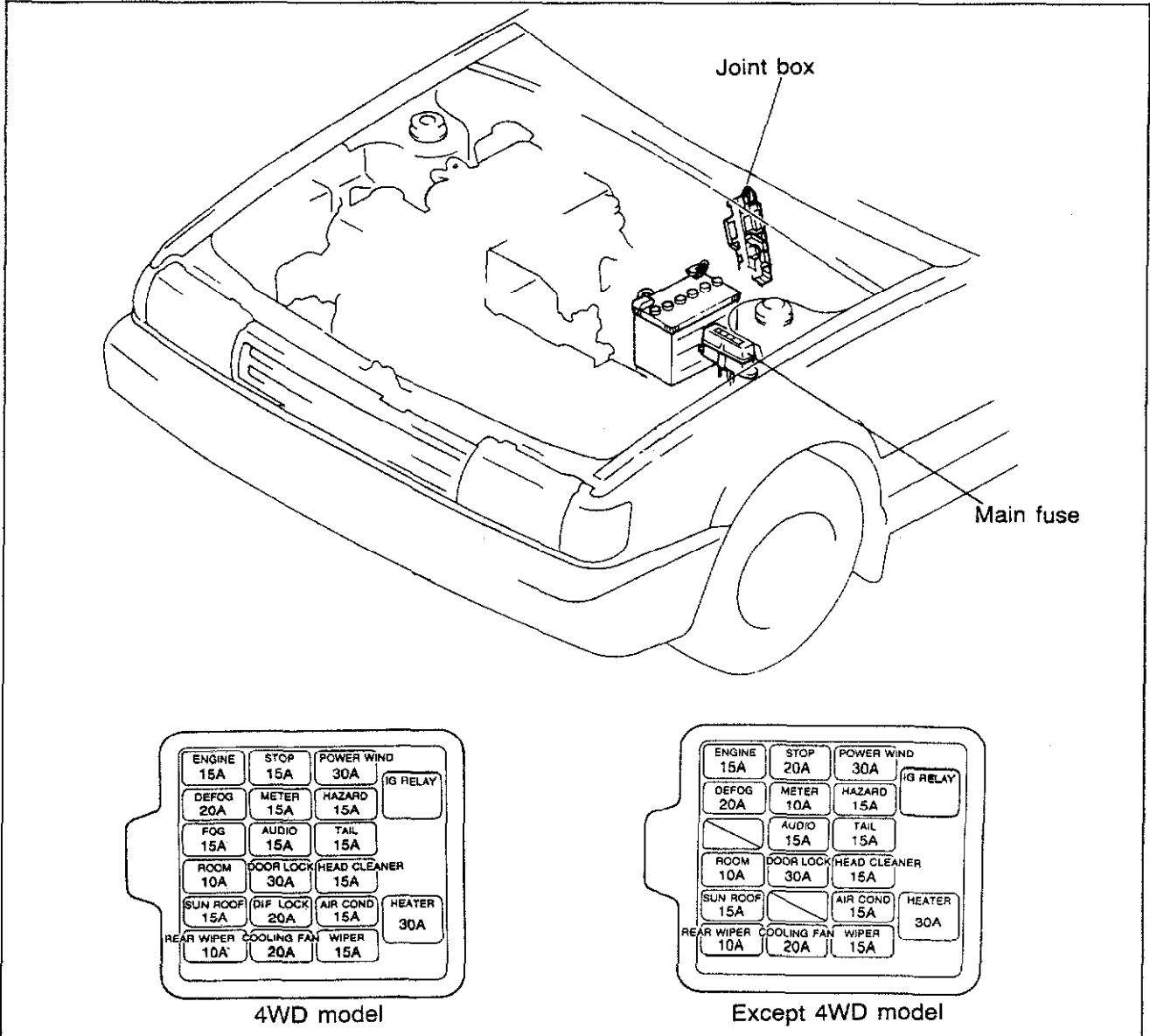

63U15X-007

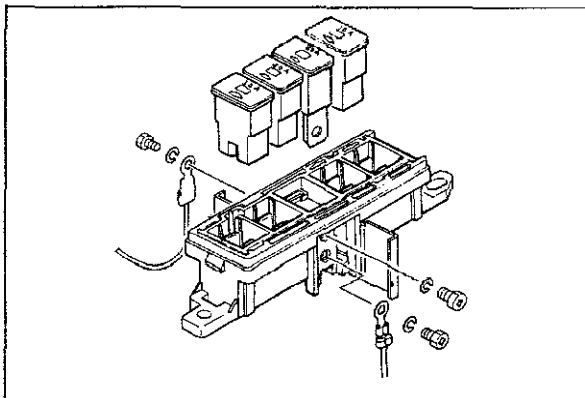

5BU15X-081

### Replacement of Main Fuse

Disconnect the battery (-) terminal  
30A fuse: pull out and push in a new one.  
80A fuse:

1. Remove the main fuse box.
2. Open the cover.
3. Remove the terminal.
4. Pull out and push in a new fuse.

**SWITCHES, RELAYS AND CONTROL UNITS**

**STRUCTURAL VIEW**

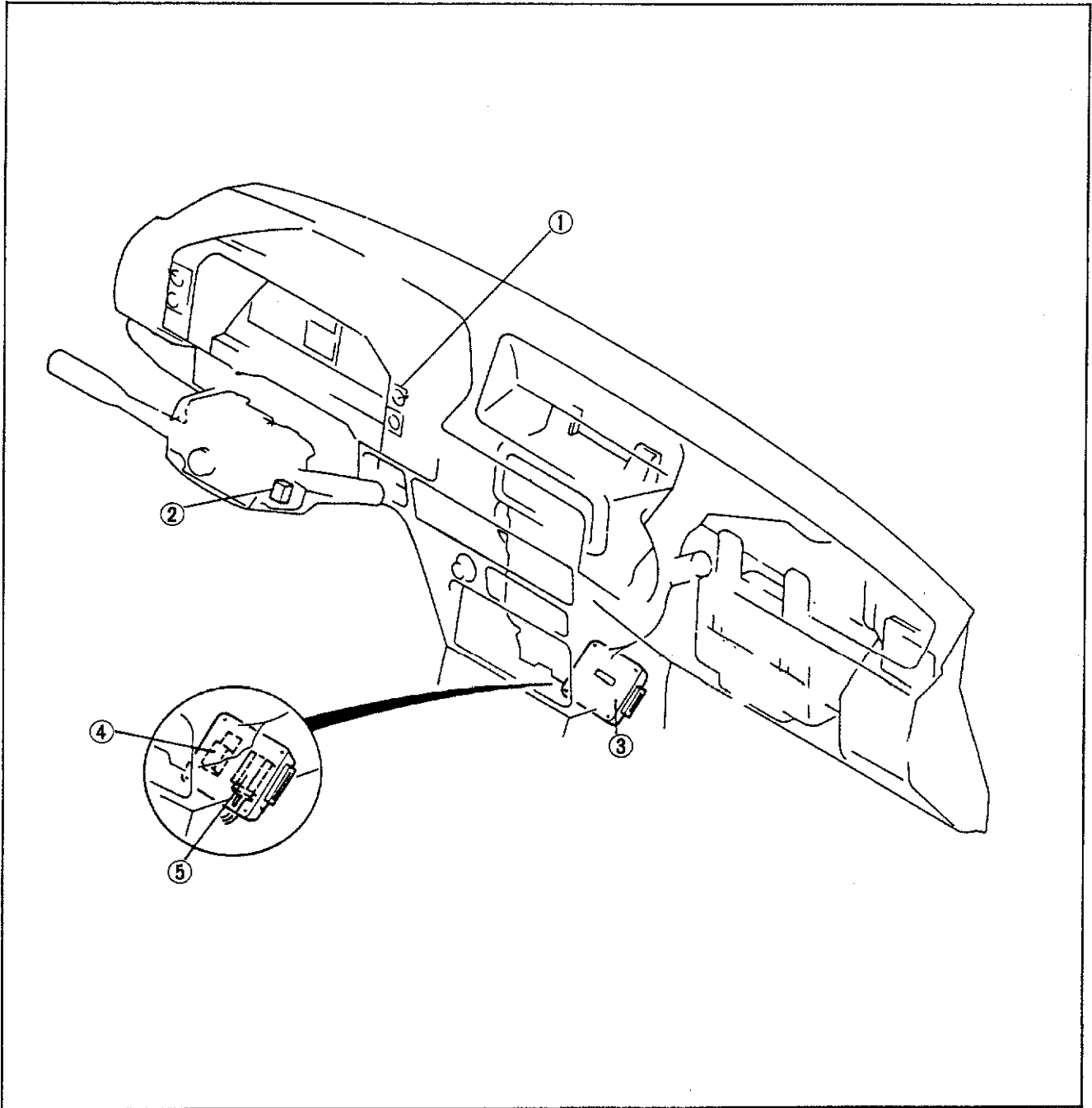

83U15X-003

1. Panel light control switch  
2. Intermittent wiper unit

3. Engine control unit  
4. Control unit (idle up)

5. Circuit open relay

# 15 SWITCHES, RELAYS AND CONTROL UNITS

## STRUCTURAL VIEW

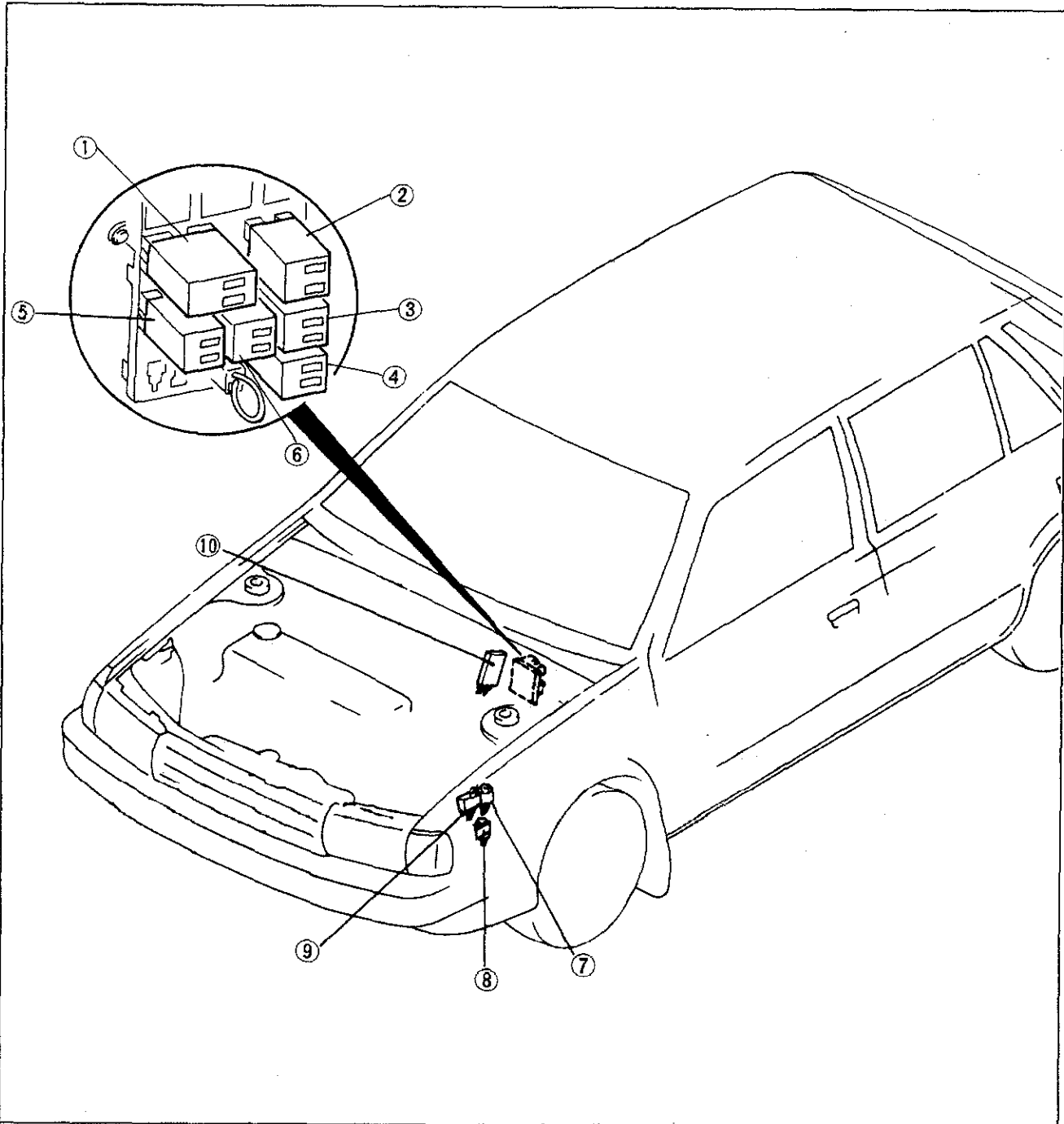

83U15X-110

- 1. Door lock relay
- 2. Flasher unit
- 3. Entry timer unit
- 4. Stop light checker
- 5. Oscillator

- 6. Timer & buzzer unit
- 7. Electrical fan relay
- 8. EGI main relay
- 9. Horn relay
- 10. Cruise control unit

## STRUCTURAL VIEW

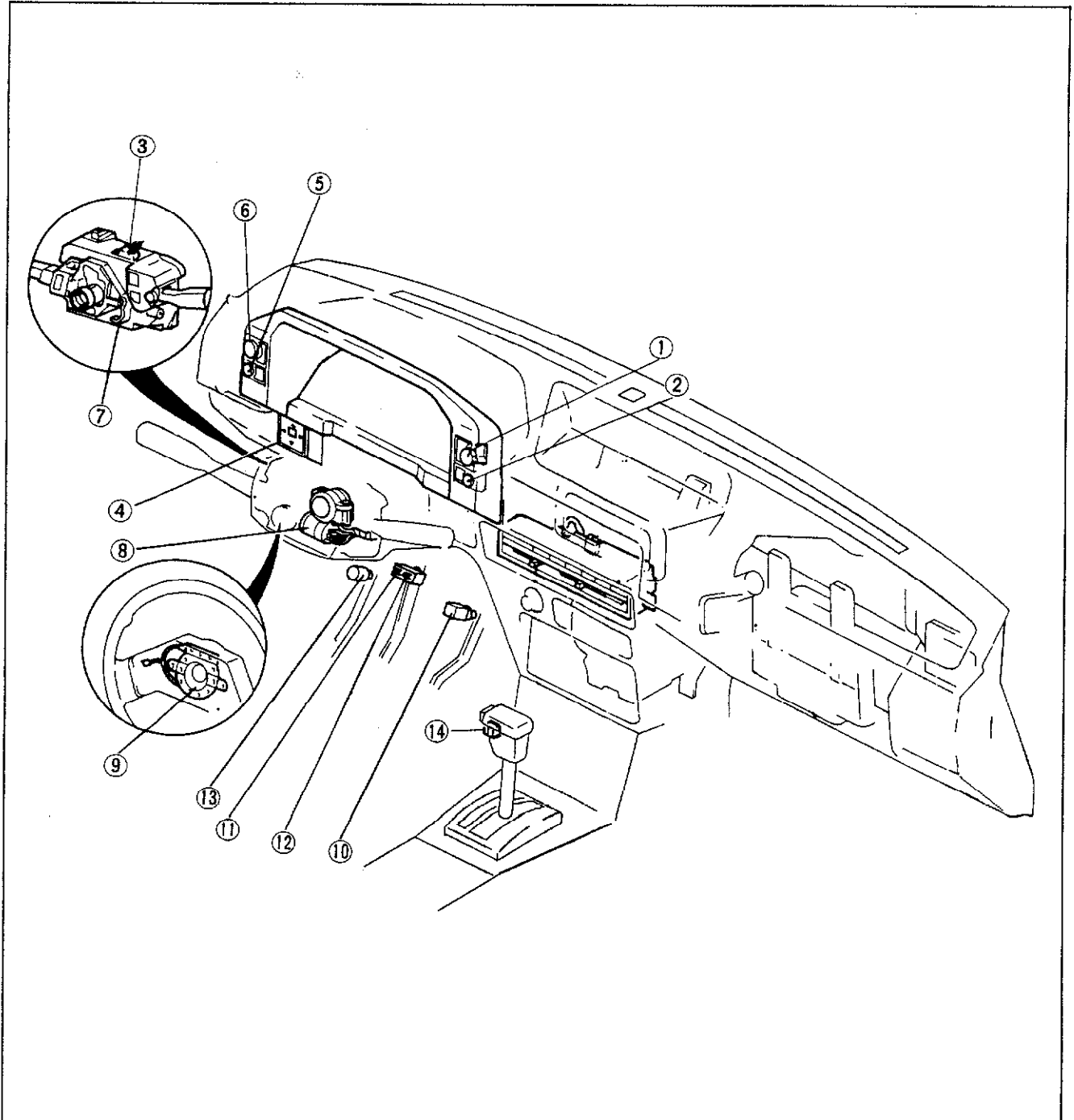

83U15X-004

- |                                 |                                      |                          |
|---------------------------------|--------------------------------------|--------------------------|
| 1. Panel light controller       | 7. Combination switch                | 13. Clutch switch (MTX)  |
| 2. Cruise control main switch   | 8. Ignition key switch               | 14. O/D off switch (ATX) |
| 3. Hazard switch                | 9. Horn switch                       |                          |
| 4. Remote mirror switch         | 10. Kickdown switch (ATX)            |                          |
| 5. Rear window defroster switch | 11. Stop switch (for cruise control) |                          |
| 6. Rear wiper and washer switch | 12. Stop light switch                |                          |



# 15 SWITCHES, RELAYS AND CONTROL UNITS

## STRUCTURAL VIEW

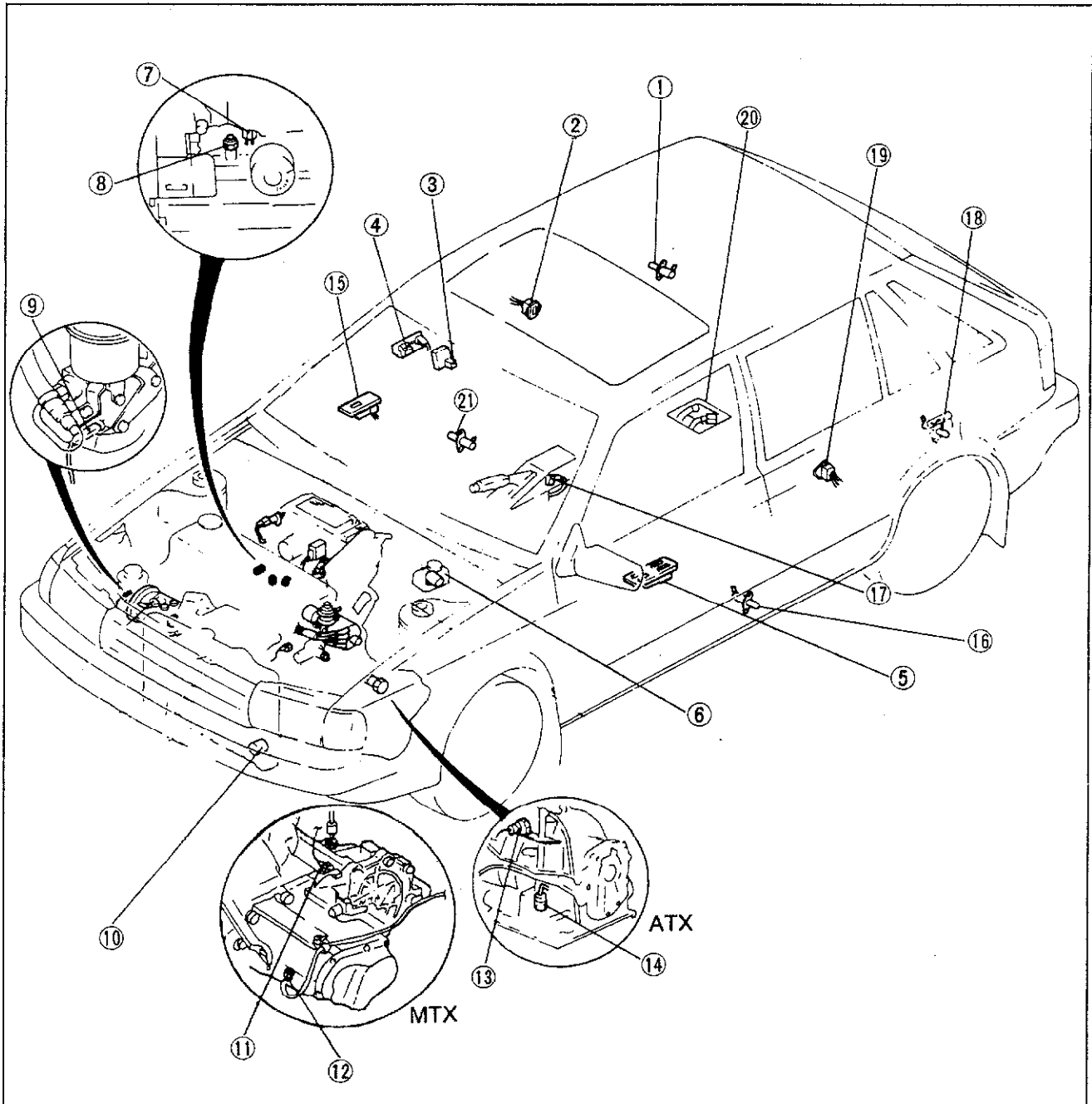

83U15X-111

- |   |   |                     |
|---|---|---------------------|
| 1. Door switch                            | 10. Water temperature switch (radiator) | 20. Fuel gauge unit |
| 2. Power window switch                    | 11. Neutral switch (MTX)                | 21. Door switch     |
| 3. Door lock switch                       | 12. Back lamp switch                    |                     |
| 4. Door handle switch                     | 13. Neutral switch (ATX)                |                     |
| 5. Power window main switch               | 14. Inhibitor switch (ATX)              |                     |
| 6. Brake fluid level switch               | 15. Power window switch                 |                     |
| 7. Water temperature switch (engine side) | 16. Door switch                         |                     |
| 8. Oil pressure switch                    | 17. Parking brake switch                |                     |
| 9. Power steering switch                  | 18. Door switch                         |                     |
|   | 19. Power window switch                 |                     |

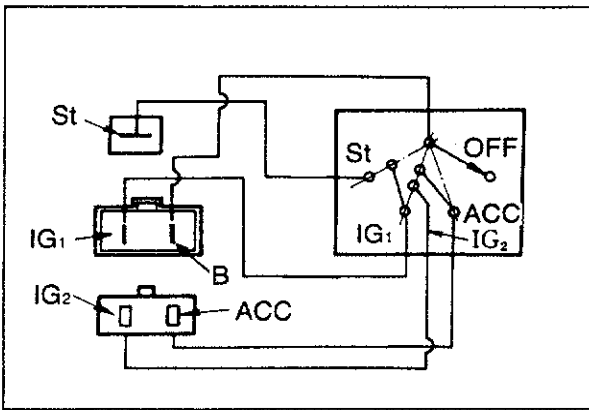

5BU15X-008

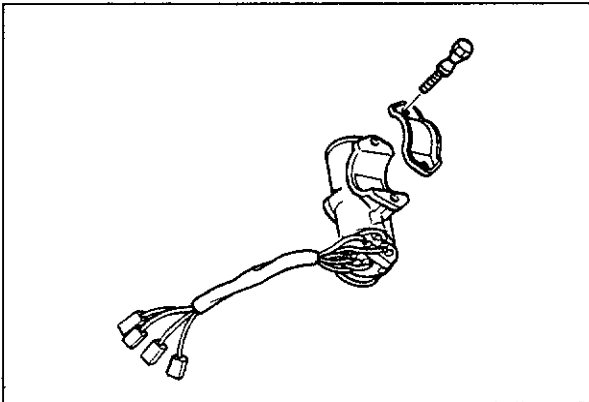

63U15X-013

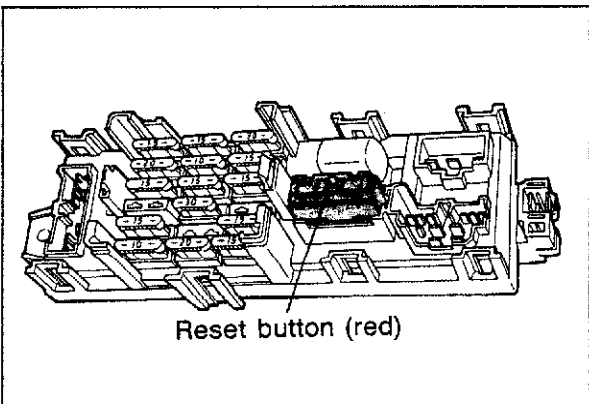

63U15X-014

## IGNITION KEY SWITCH

### INSPECTION

1. Use an ohmmeter to check the continuity of the terminals of the switch.  
If the continuity is not as specified, replace the switch.

Terminal Position	B	ACC	IG1	IG2	ST
LOCK (OFF)					
ACC	○—○				
ON	○—○	○—○	○—○	○—○	
START			○—○		○—○

○—○ :Indicates continuity

### REPLACE

See section 10.

## CIRCUIT BREAKER (In the joint box)

When the circuit breaker is open, check and repair the heater blower circuit, and then reset the breaker by pushing the reset button (red).

# 15 COMBINATION SWITCH

## COMBINATION SWITCH

### STRUCTURAL VIEW

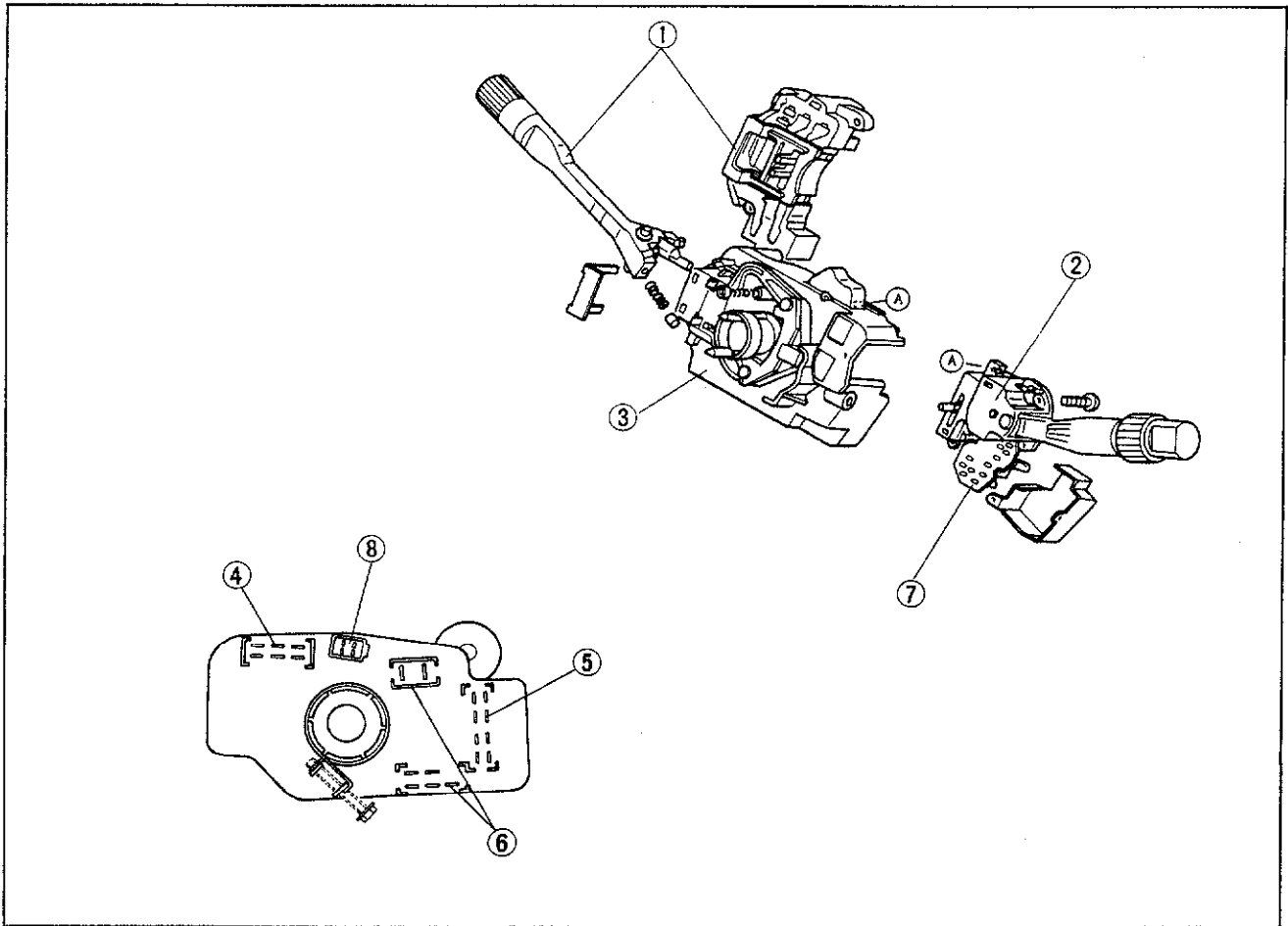

83U15X-005

- |                            |                            |                            |
|----------------------------|----------------------------|----------------------------|
| 1. Light switch assembly   | 4. Wiper and washer switch | 7. Intermittent wiper unit |
| 2. Wiper unit assembly     | 5. Turn and hazard switch  | 8. Cruise control switch   |
| 3. Combination switch body | 6. Light switch            |                            |

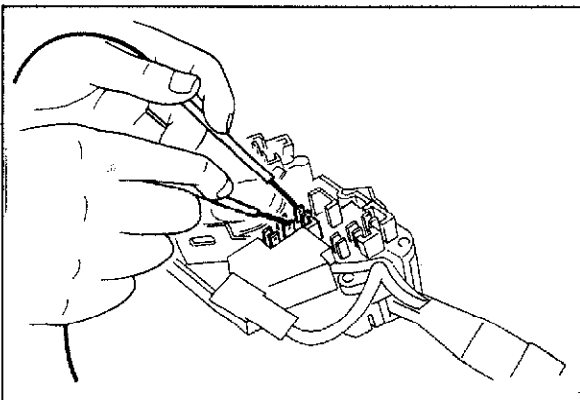

63U15X-016

### INSPECTION

Use an ohmmeter to check the continuity of the terminals of the switch.  
If continuity is not as specified, replace the switch.

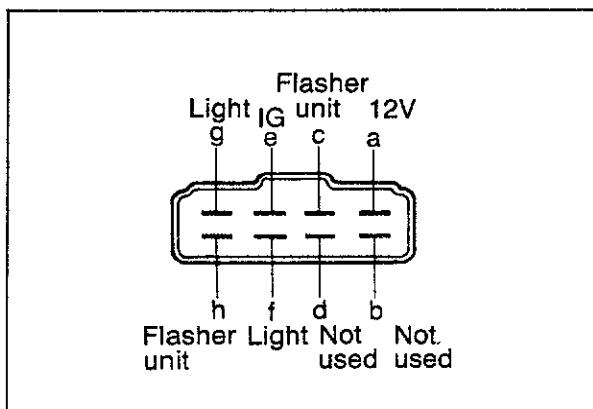

83U15X-006

### Turn Signal and Hazard Switch

Turn switch	Hazard switch	a	c	e	f	g	h
OFF	OFF		○—○				
Right	OFF		○—○		○—○		○—○
Left			○—○			○—○	
OFF	ON	○—○			○—○	○—○	○—○

○—○: Indicates conductive

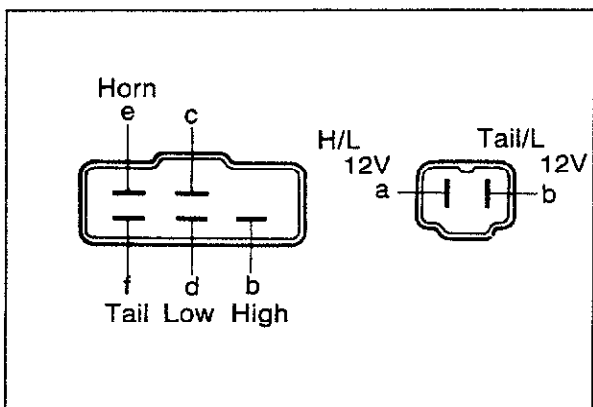

83U15X-007

### Light Passing Switch and Horn Switch

Terminal		6P				2P	
		b	c	d	f	a	b
Position							
OFF							
First and second					○—○		○—○
Second	Lo		○—○	○—○		○—○	
	Hi	○—○	○—○	○—○		○—○	
Passing		○—○				○—○	

○—○: Indicates conductive

• "e" terminal is conductive to the plate when the horn switch is ON.

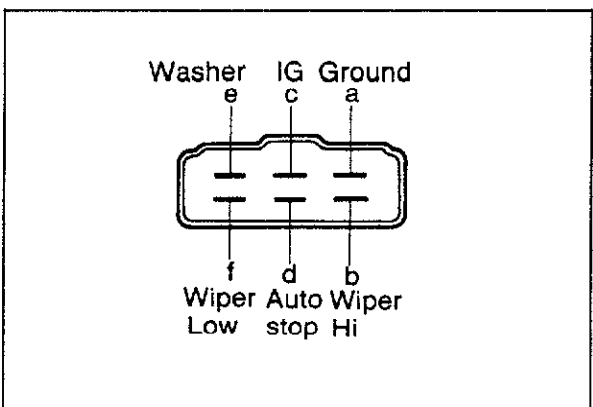

83U15X-008

### Windshield Wiper and Washer Switch

Terminal		a	b	d	e	f
		Position				
Wiper switch	OFF	One touch OFF			○—○	○—○
		One touch ON	○—○			○—○
	INT		○—○			○—○
	I		○—○			○—○
	II		○—○	○—○		
Washer ON		○—○			○—○	

○—○: Indicates conductive

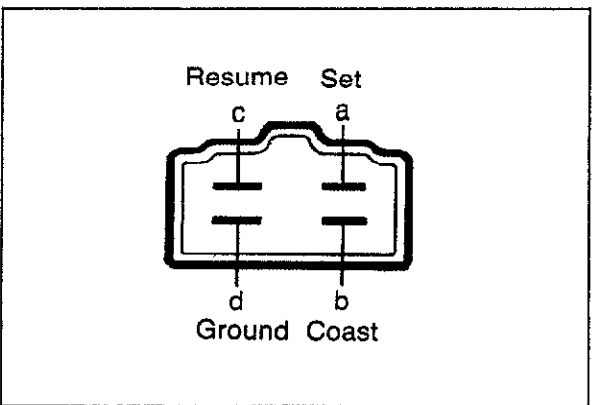

83U15X-009

### Cruise control switch

Terminal		a	b	c	d
		Position			
OFF					
SET		○—○			○—○
RESUME				○—○	○—○
COAST			○—○		○—○

○—○: Indicates conductive

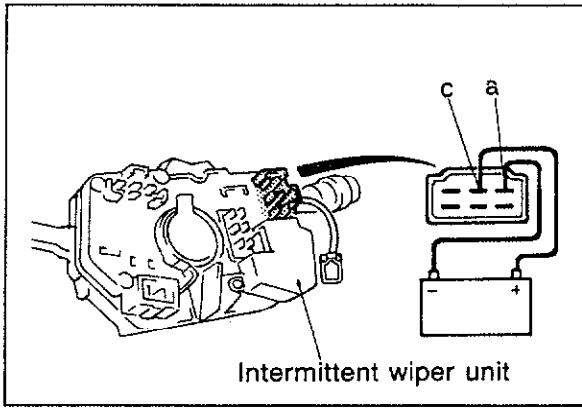

83U15X-010

## INTERMITTENT WIPER UNIT

1. With the switch in the INT position, check for the clicking sound of the relay by connecting the 12V lead to the "c" terminal and the ground to the "a" terminal.
2. With the switch in the OFF position, connect 12V to the "c" terminal and ground the "a" terminal. Then check for the relay clicking sound when the switch is turned ON, and for another clicking sound about 3 seconds after the switch is returned to OFF.

### Caution

**Do not reverse connect the electrical source to the terminals.**

CLUSTER SWITCH

STRUCTURAL VIEW

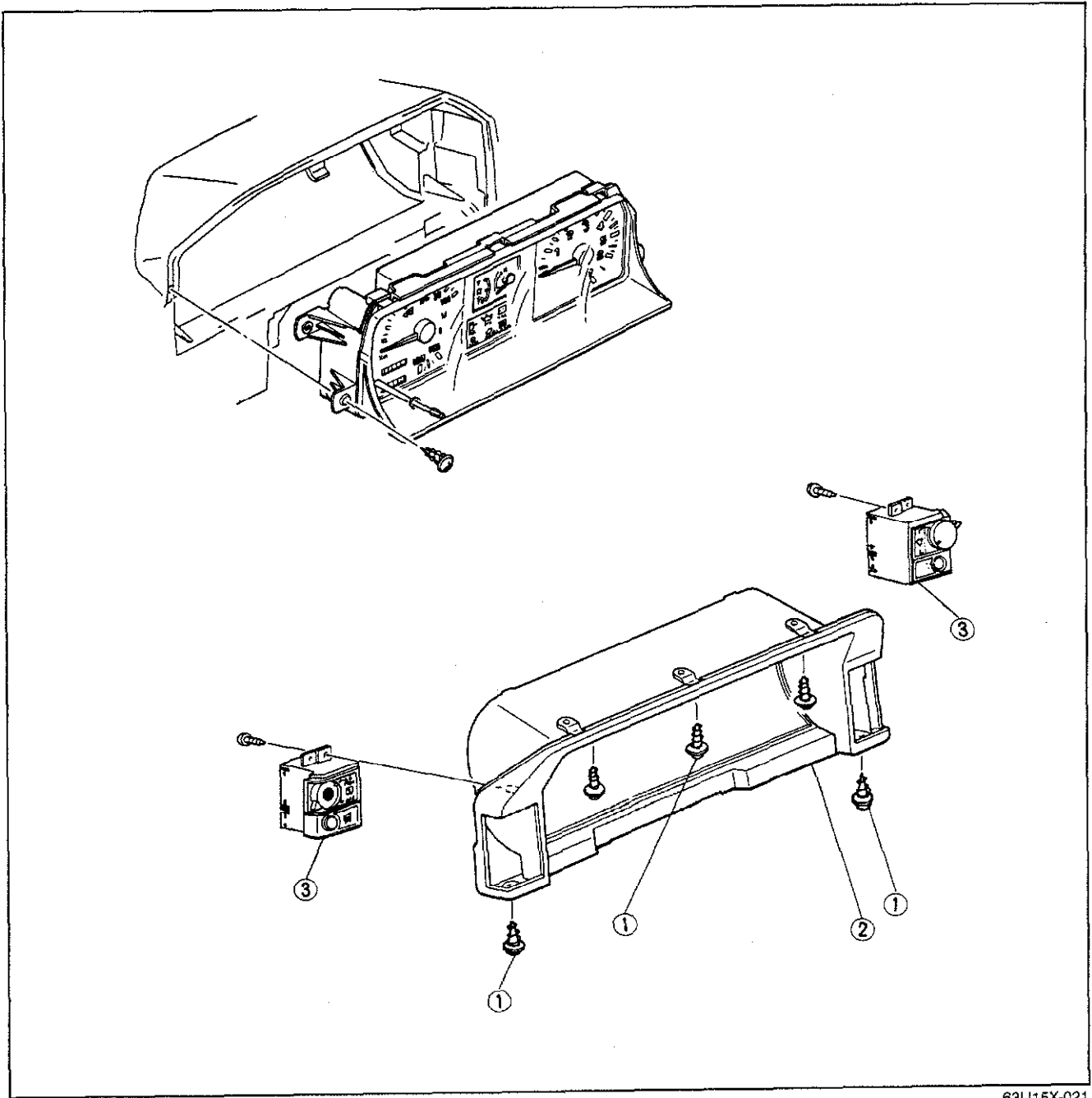

63U15X-021

1. Bolts

2. Meter hood

3. Cluster switch

# 15 CLUSTER SWITCH

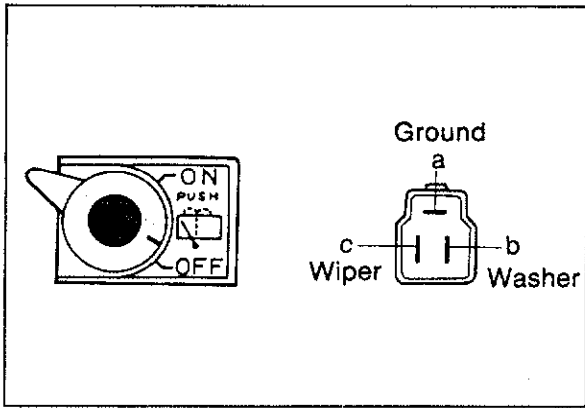

83U15X-011

## INSPECTION

Check for continuity between the terminals by using a circuit tester or ohmmeter.

### Rear Wiper and Washer Switch

	a	b	c
OFF			
Wiper: ON		○—○	○
Washer: ON	○—○		

○—○: Indicates continuity

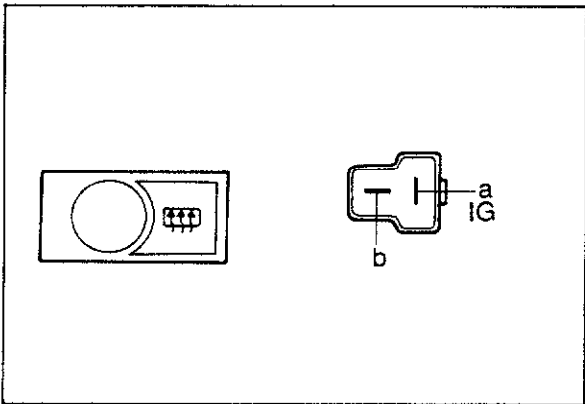

83U15X-012

### Rear Defroster Switch

	a	b
OFF		
ON	○—○	○

○—○: Indicates continuity

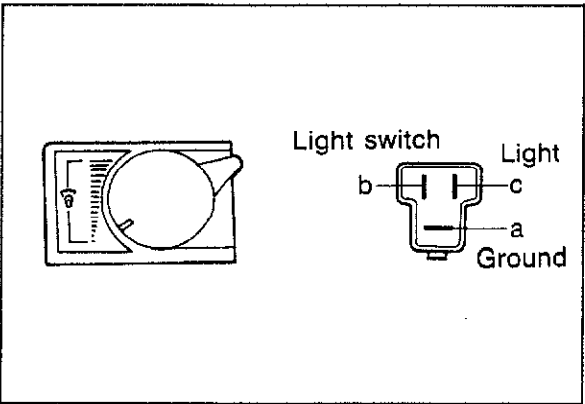

83U15X-013

### Panel Light Control Switch

Connect the 12V probe to the "b" terminal and the ground to the "a" terminal.

Check that the "c" terminal voltage to the ground changes with the turning angle of the control knob.

**Control knob Minimum ↔ Maximum**

**Voltage 0V ↔ 12V**

### Caution

a) Do not misconnect the electrical source to the terminals.

b) Never supply 12V to the "c" terminal. (Controller will burn out instantly.)

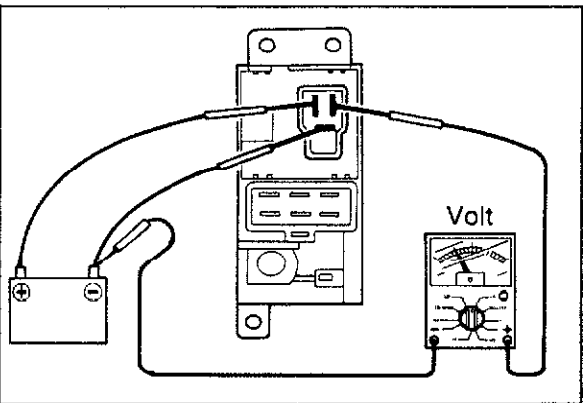

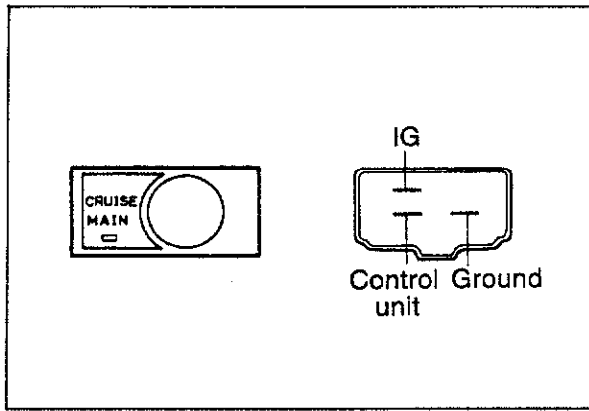

83U15X-014

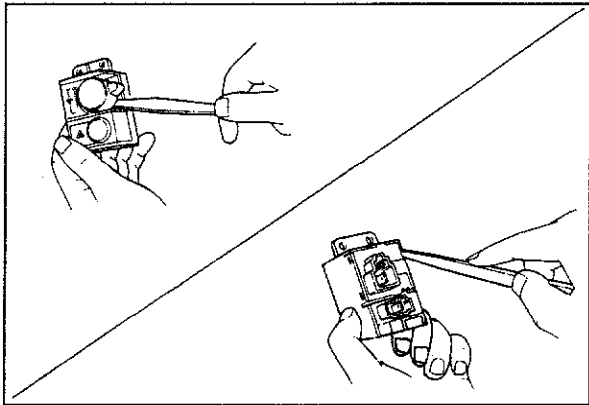

83U15X-015

## Cruise Control Main Switch

	a	b	c	d
OFF				
ON	○	○	○	

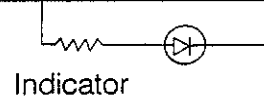

○—○: Indicates conductive

## DISASSEMBLY & ASSEMBLY

1. Pry off the switch knob.
2. Release the lock pins, and remove the switch from the rear side.
3. Assemble in the reverse order of disassembly.

**Caution**  
Do not damage the switch body.



## METER

### STRUCTURAL VIEW

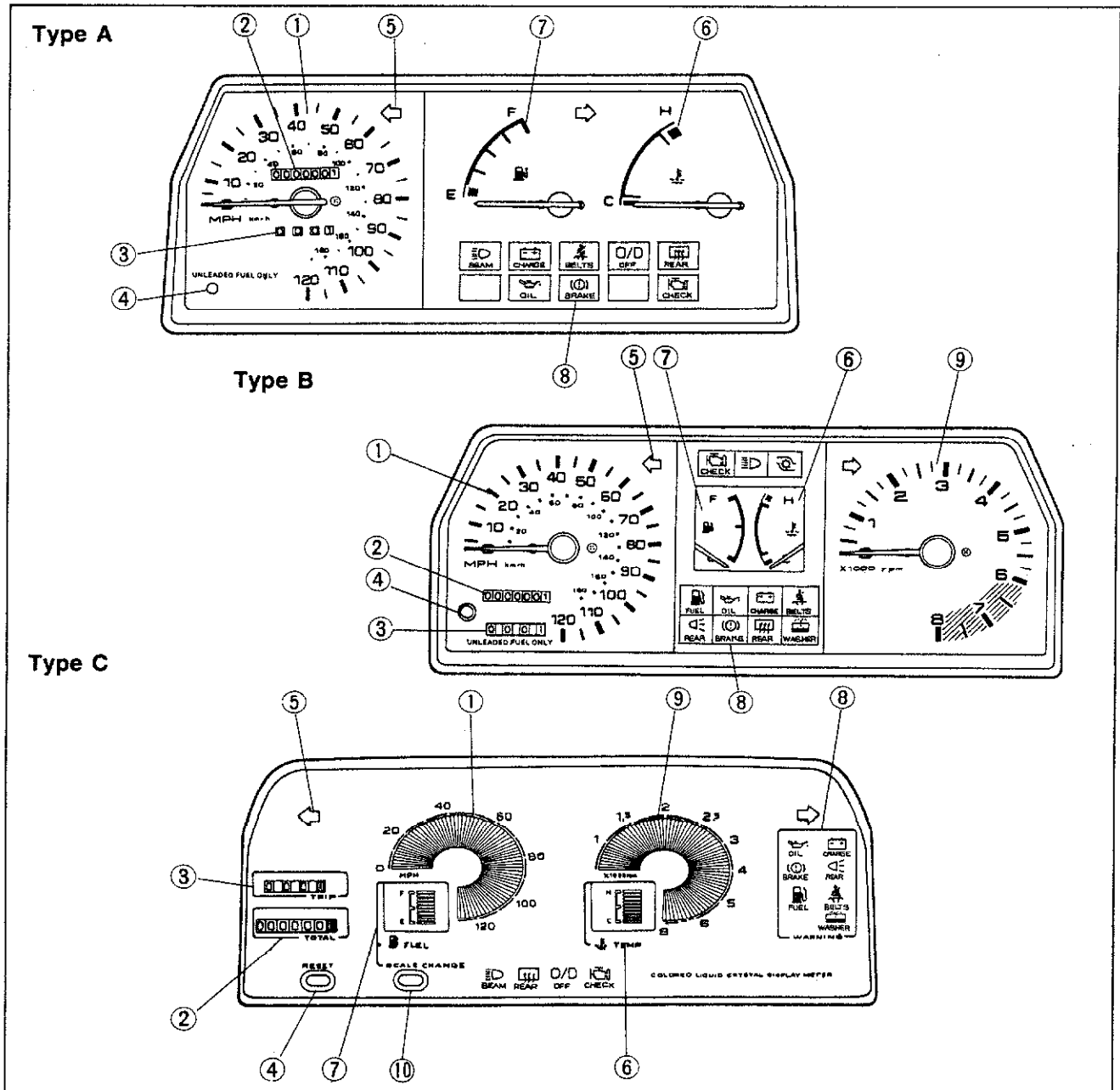

83U15X-016

- 1. Speedometer
- 2. Odometer
- 3. Tripmeter
- 4. Tripmeter reset knob

- 5. Turn-signal/hazard warning flasher light
- 6. Water temp. gauge
- 7. Fuel gauge

- 8. Warning and indicator lights
- 9. Tachometer
- 10. Fuel gauge scale change knob

**DISASSEMBLY AND ASSEMBLY**

1. Disassemble in the numbered sequence shown in the figure.
2. Assembly is in the reverse order of disassembly.

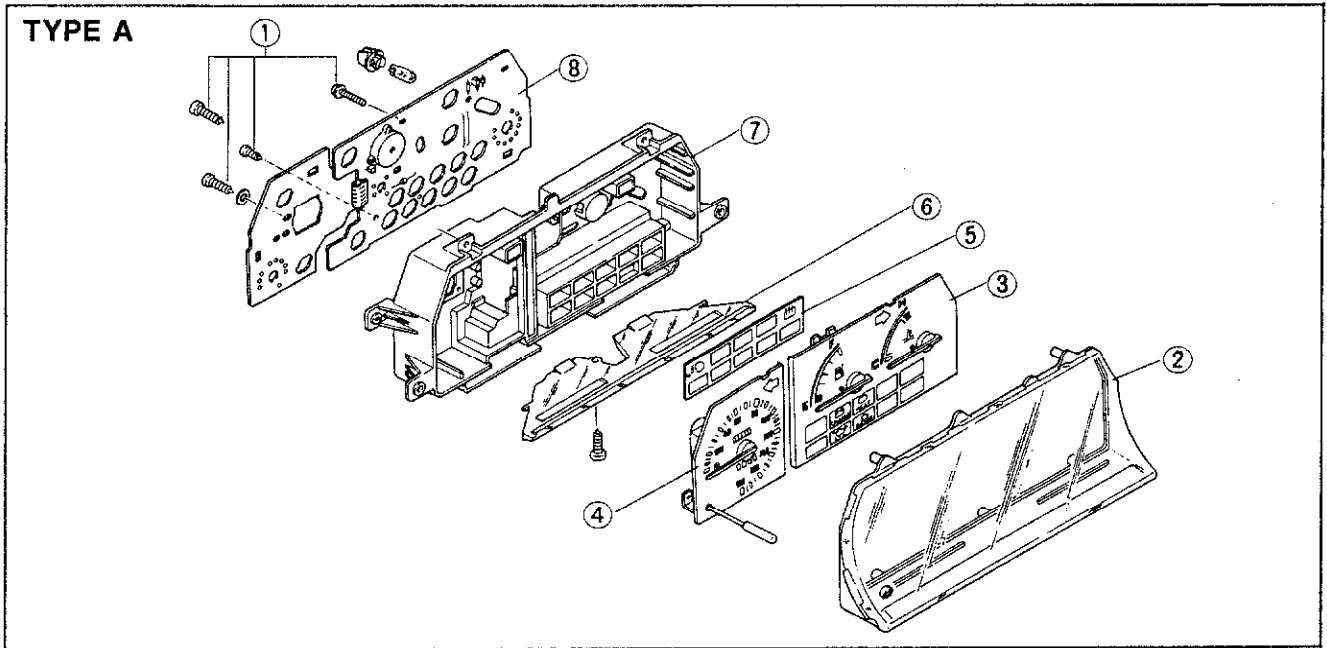

63U15X-036

- |                                |                                     |                          |
|--------------------------------|-------------------------------------|--------------------------|
| 1. Screws                      | 3. Water temp. gauge and fuel gauge | 6. Illumination panel    |
| 2. Front lens and window plate | 4. Speedometer                      | 7. Meter case            |
|                                | 5. Warning plate                    | 8. Printed circuit board |

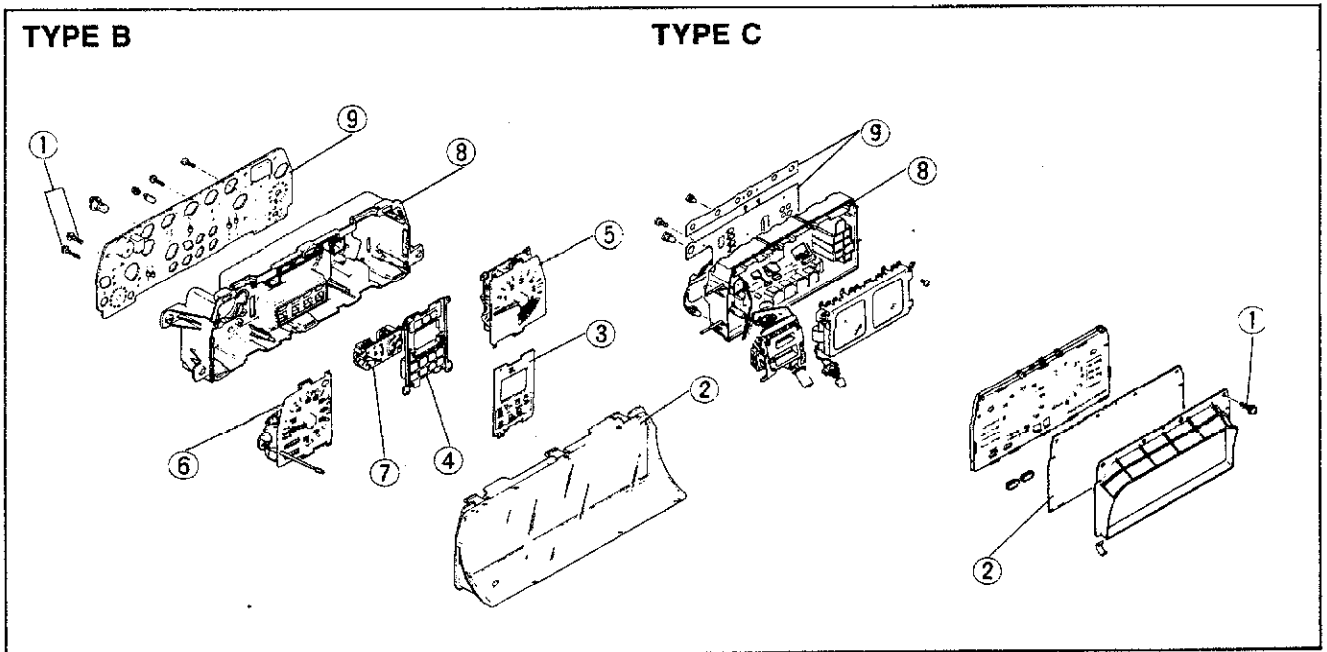

63U15X-037

- |                                |                 |                                    |
|--------------------------------|-----------------|------------------------------------|
| 1. Screws                      | 4. Warning case | 7. Water temp gauge and fuel gauge |
| 2. Front lens and window plate | 5. Tachometer   | 8. Meter case                      |
| 3. Warning plate               | 6. Speedometer  | 9. Printed circuit board           |

# 15 METER (INCL. SENDER UNITS)

## TROUBLESHOOTING GUIDE

Problem	Possible Cause	Remedy	Page
<b>Speedometer does not work</b>	Speedometer cable and connection Speedometer Speedometer drive gear	Replace or repair Replace speedometer Replace speedometer drive gear	15—21
<b>Speedometer fluctuation</b>	Speedometer cable Speedometer Loose cable connection	Replace speedometer cable Replace speedometer Repair	15—21
<b>Tachometer does not work</b>	METER fuse blown Short circuit Tachometer Wiring	Replace fuse and check for short Repair Check or replace tachometer Repair as necessary	15—21
<b>Fuel gauge does not work</b>	METER fuse blown Short circuit Fuel gauge Fuel tank unit Ground or wiring	Replace fuse and check for short Repair Replace fuel gauge Replace fuel tank unit Repair as necessary	15—21
<b>Water temperature gauge does not work</b>	METER fuse blown Short circuit Water temperature gauge Water temperature gauge unit Wiring	Replace fuse and check for short Repair Replace water temperature gauge unit Replace water temperature gauge unit Repair as necessary	15—24

83U15X-017

### Analog meter

Standard indication (km/h)	Allowable range (km/h)
40	37— 40
80	76— 80
120	114—120

Standard indication (mph)	Allowable range (mph)
30	28.0—30.0
60	57.0—60.0
90	85.5—90.0

83U15X-018

### Digital meter

Standard indication (mph)	Allowable range (mph)
30	26.0— 37.5
60	52.5— 75.0
90	79.0—112.5

83U15X-019

### ON-VEHICLE INSPECTION

#### Speedometer

- Using a speedometer tester, test the speedometer for allowable indication error, and check the operation of the odometer.
- Check the speedometer for fluctuation and/or abnormal noise.

#### Caution

- If significant fluctuation occurs or the speedometer does not move at all, remove the speedometer cable. If normal, replace the speedometer assembly.
- Tire wear and improper inflation will increase speedometer error.

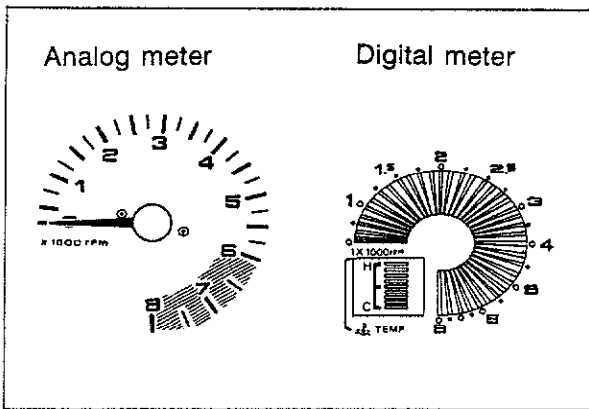

83U15X-020

## Analog meter rpm display

Standard indication (rpm)	Allowable range (rpm)
1000	910—1090
2000	1910—2090
3000	2910—3090
4000	3880—4120
5000	4850—5150
6000	5640—6360

83U15X-021

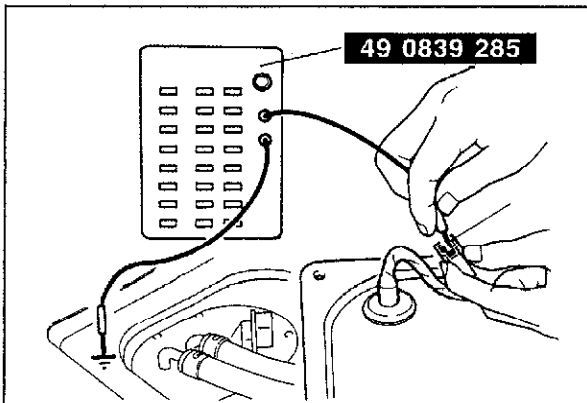

83U15X-022

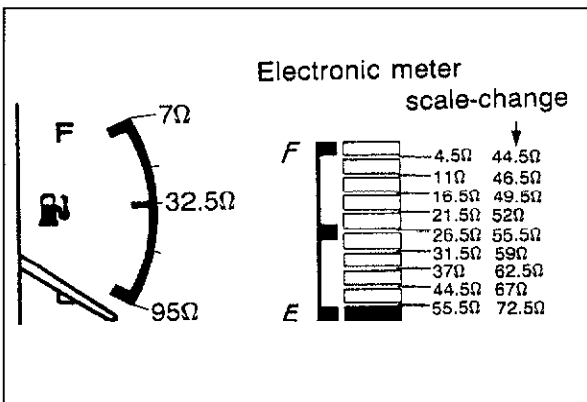

83U15X-023

## Tachometer

Compare the tester and tachometer indications. If there is significant error, replace the tachometer.

### Caution

**When removing or installing the tachometer, be careful not to drop it or subject it to sharp impact.**

## Checking for indication error

1. Connect a tester to the negative (-) terminal of the ignition coil and start the engine.
2. Compare the indication of the tester with that of the tachometer, replace the tachometer if the error is significant. (For a digital meter, replace the meter unit assembly.)

## Digital meter rpm display

Display range (rpm)	Segment	Color
0	1	Amber
1—600	2—5	Amber
601—1000	6—9	Amber
1001—3000	10—49	Amber
3001—5000	50—69	Amber
5001—6000	70—77	Amber
6001—6500	78—79	Red
6501—7500	80—83	Red
7501—8000	84—87	Red

## Fuel Gauge

1. Disconnect the connector from the fuel tank unit.
2. Connect the red lead wire of the **SST** to the connector, and the black lead wire to the body ground.
3. Set the checker to the resistance values shown in the figure.
4. Turn on the ignition switch and check to confirm that the needle indicator displays the correct values.

If the needle displays the correct values, the trouble is in the gauge unit; if not, the trouble is in the meter.

### Caution

- a) Continue the above inspections for at least two minutes each to correctly judge the condition.
- b) The allowable indication error is twice the width of the needle.

# 15 METER (INCL. SENDER UNITS)

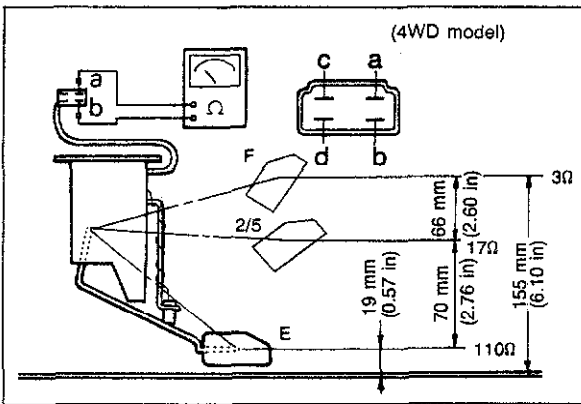

83U15X-024

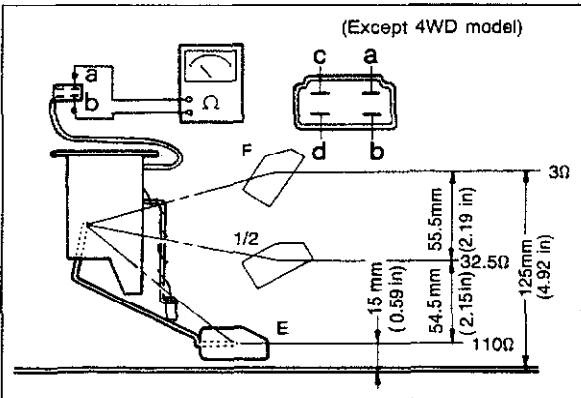

83U15X-025

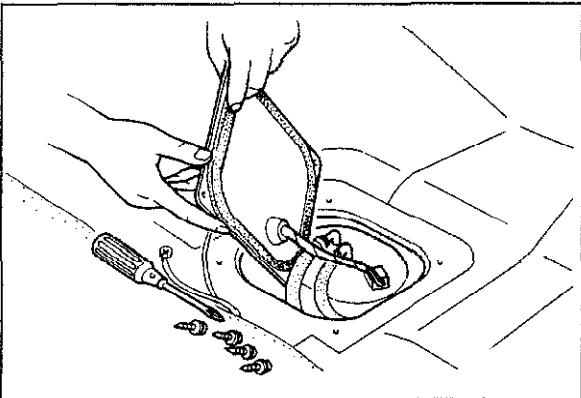

63U15X-035

## Fuel Tank Unit

1. Connect an ohmmeter to the tank unit.
2. Move the unit arm slowly from point (E) to point (F) and read the resistance value. If this value is outside the standard range, replace the unit.

### Note

To inspect the fuel tank unit, remove the fuel tank.

Remove as follows.

1. Disconnect the main fuel hose, fuel return hose and evaporation hoses from the fuel tank.
2. Remove the fixing bolts and fuel tank.
3. Remove the fuel tank unit.

Installation is in the reverse order of removal.

### Warning

When removing the fuel tank, keep sparks, cigarettes and open flames away from the fuel tank.

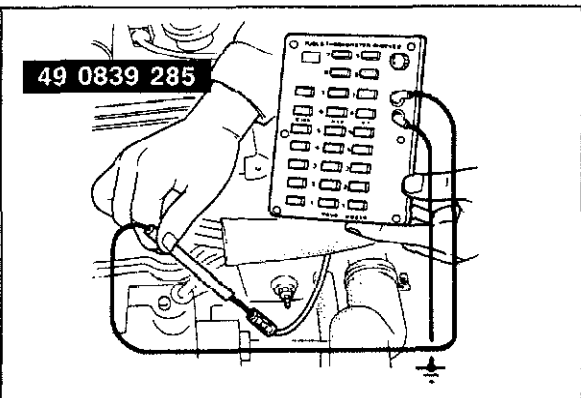

83U15X-112

## Water Temperature Gauge

1. Remove the connector from the gauge unit.
2. Connect the red lead wire of the **SST** to the connector, and the black lead wire to body ground.

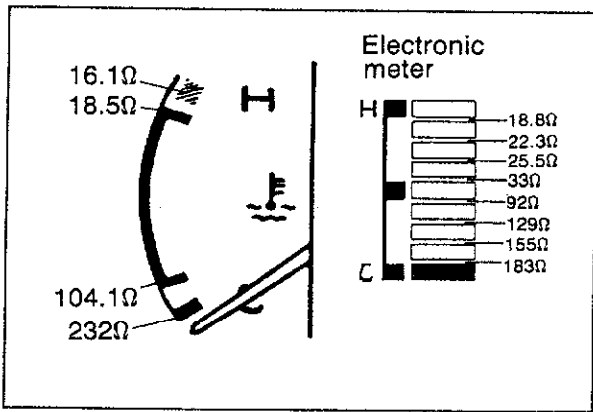

83U15X-026

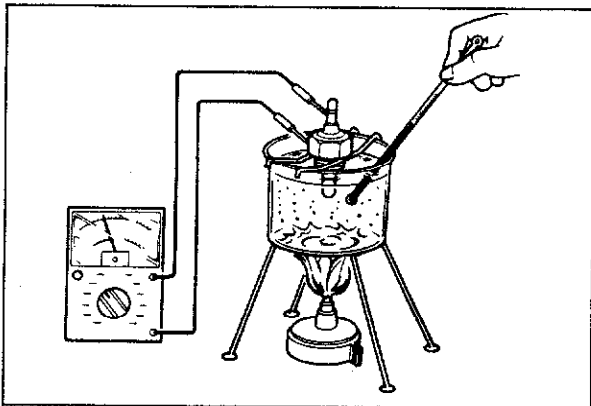

47U15X-027

3. Set the checker to the resistance values shown in the figure.
4. Turn on the ignition switch and check to confirm that the needle indicator displays the correct values. If the needle displays the correct values, the trouble is in the gauge unit; if not, the trouble is in the meter.
5. When the meter indicates  $18.8 \pm 3.0$  ohms or less, the segments will start flashing.

### Note

a) Continue the above inspections for at least two minutes each to correctly judge the condition.

b) The allowable indication error is twice the width of the needle.

### Water Temperature Gauge Unit

1. Remove the gauge unit.
2. Place the gauge unit in a container of water, and heat the water to **80°C (176°F)**.
3. Use an ohmmeter to measure the resistance.

**Resistance: 57.7—49.3 Ω**



## TROUBLESHOOTING

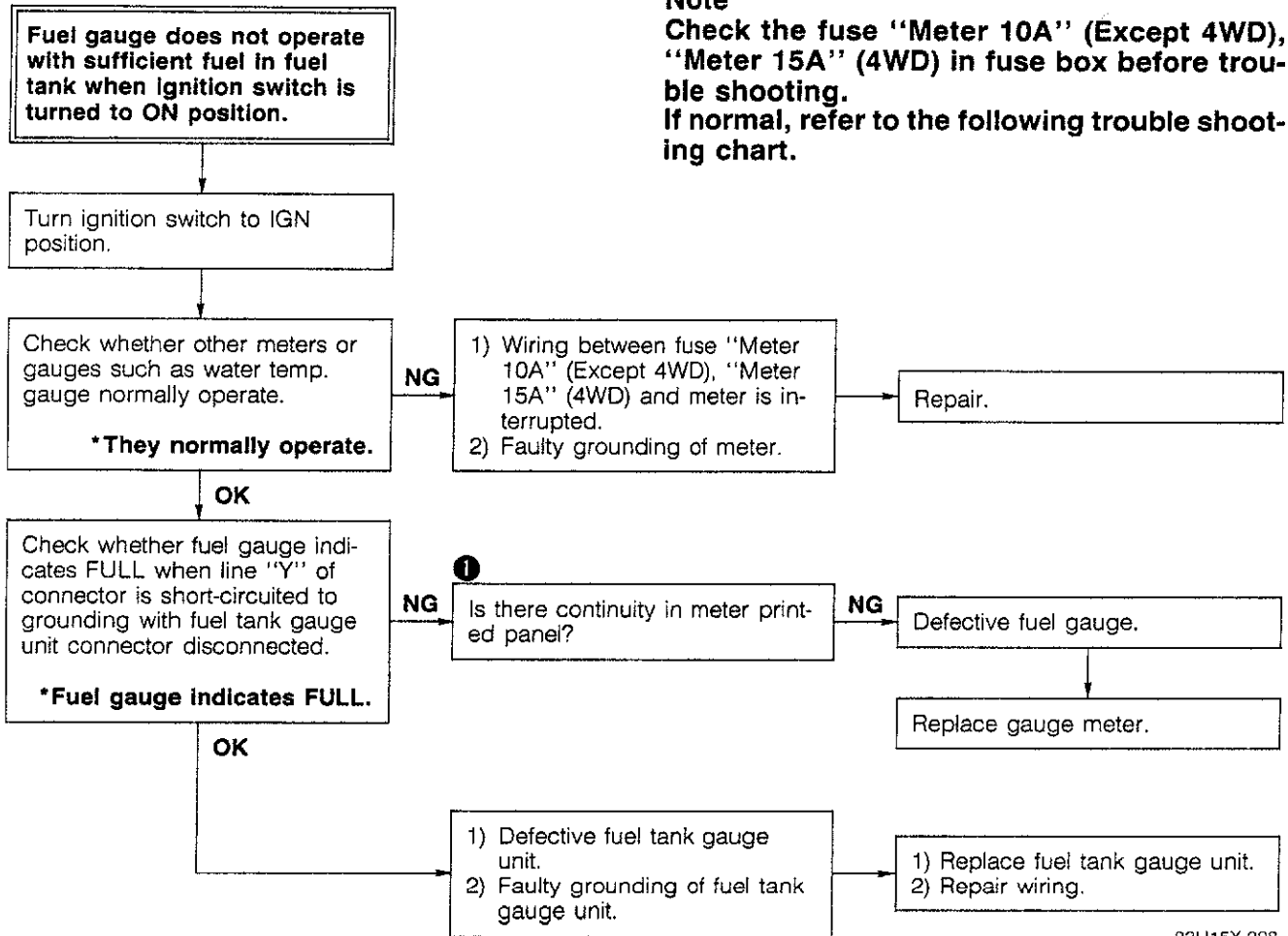

83U15X-028



# 15 METER (INCL. SENDER UNITS)

**Note**  
Check the fuse "Meter 10A" (Except 4WD),  
"Meter 15A" (4WD) in fuse box before trouble shooting.  
If normal, refer to the following trouble shooting chart.

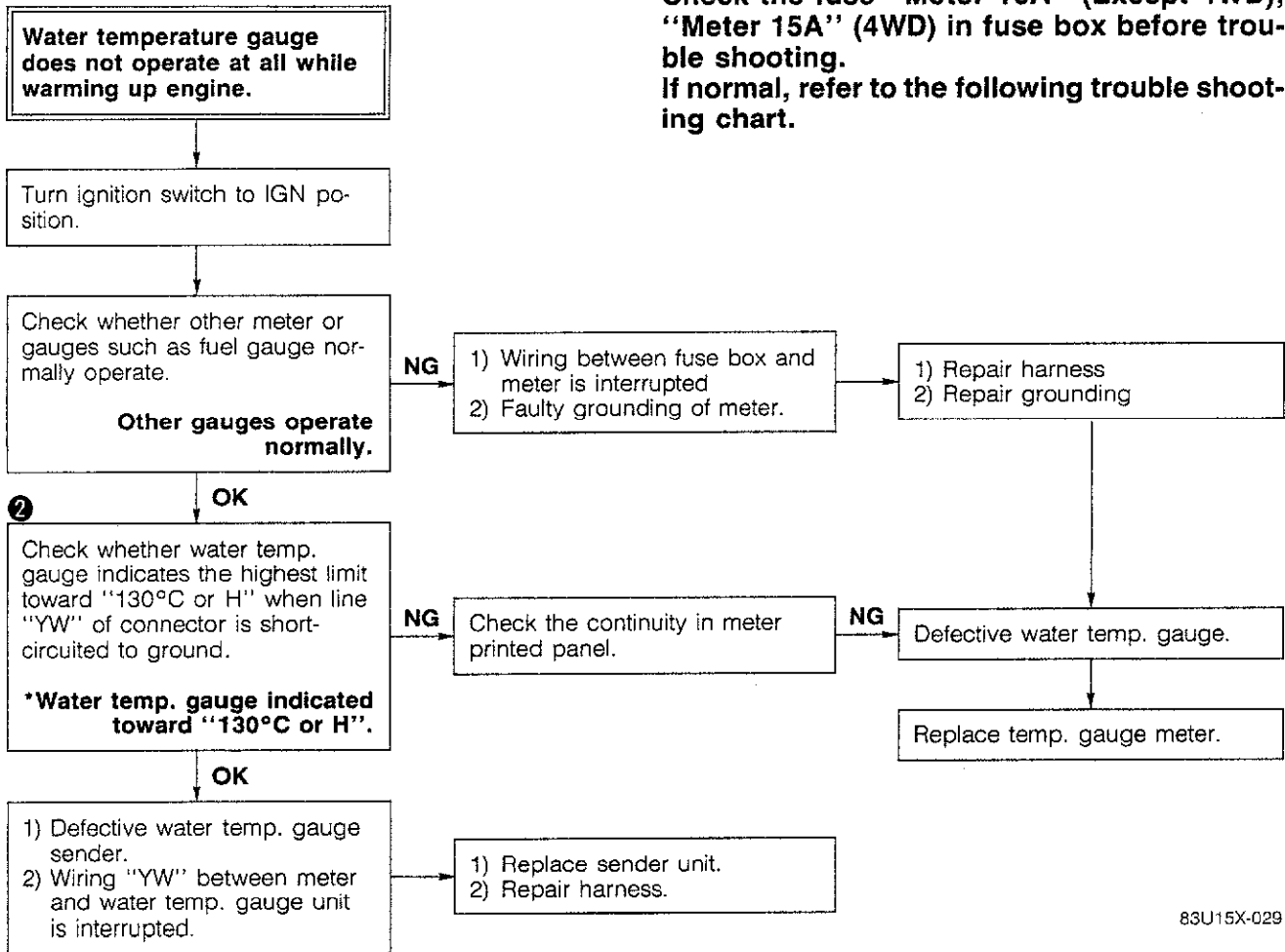

83U15X-029

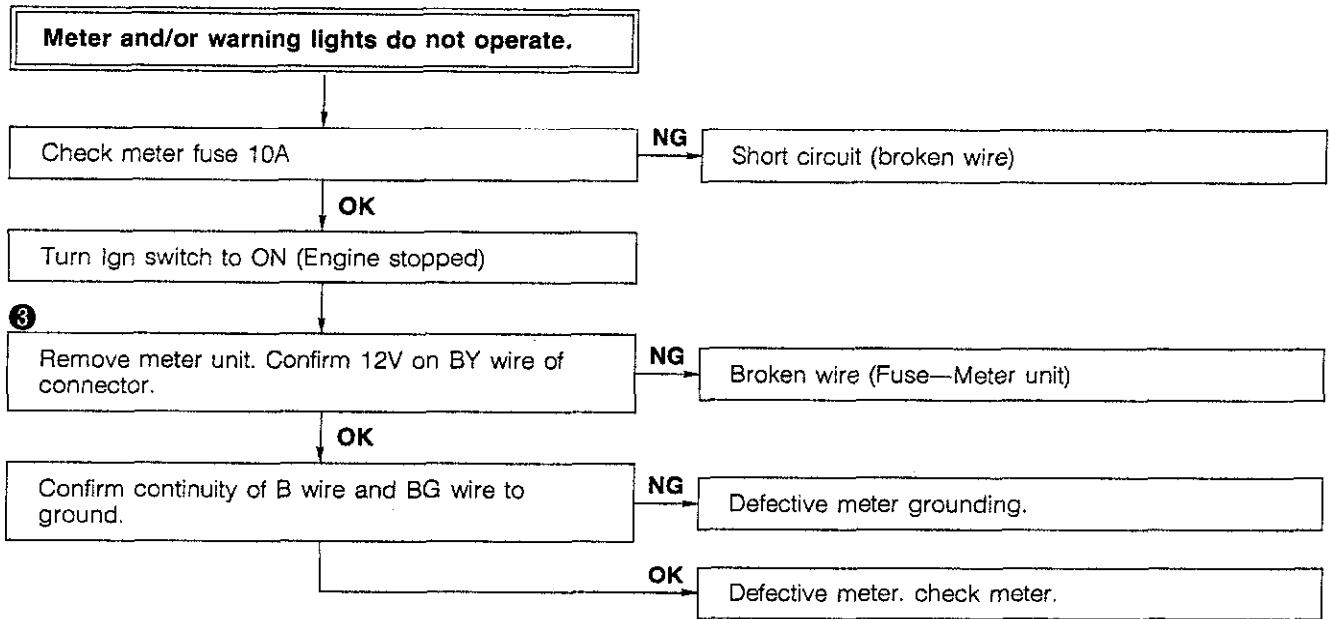

83U15X-030

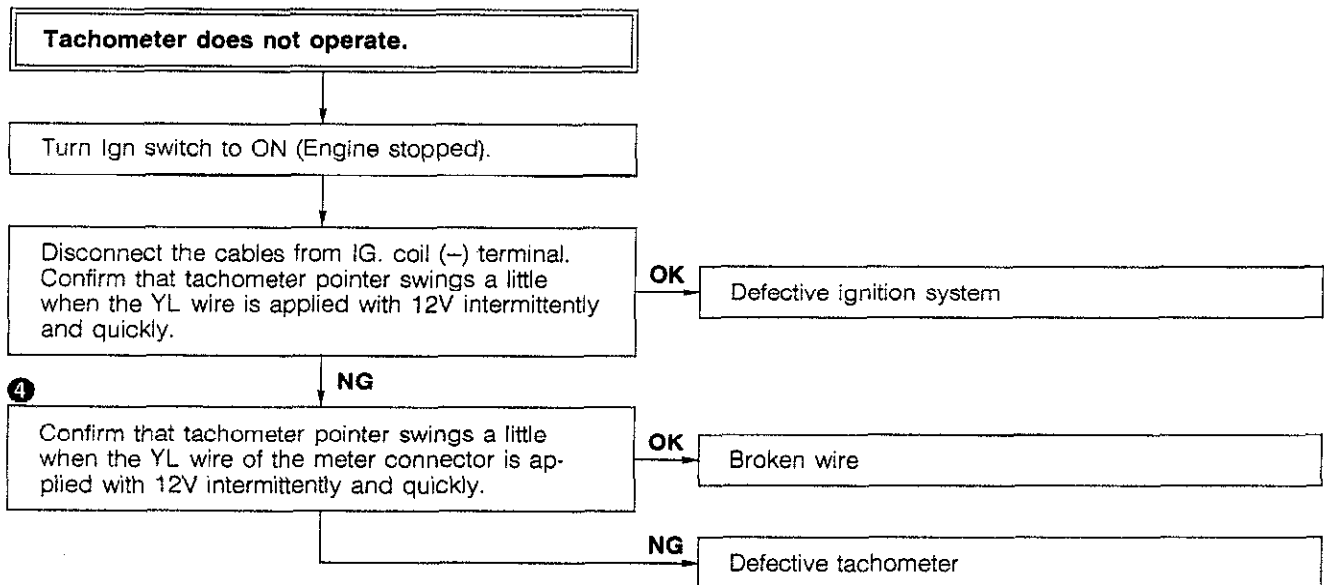

83U15X-031

# 15 METER (INCL. SENDER UNITS)

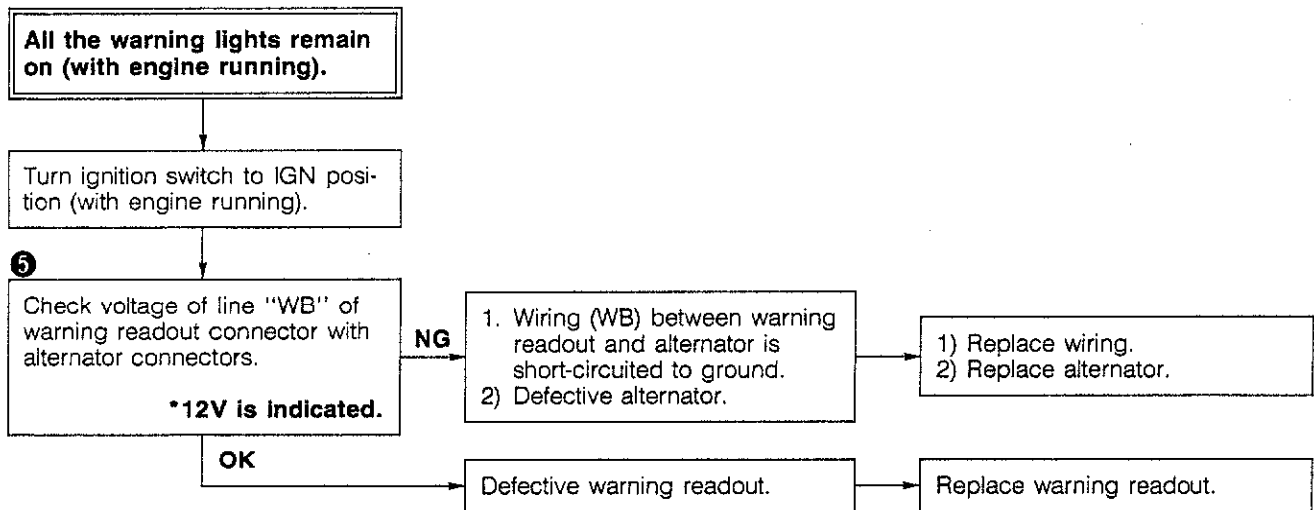

83U15X-032

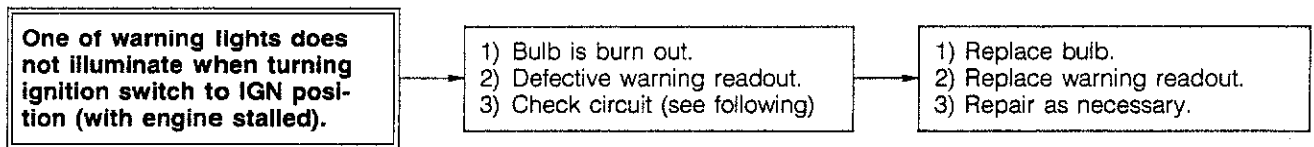

83U15X-033

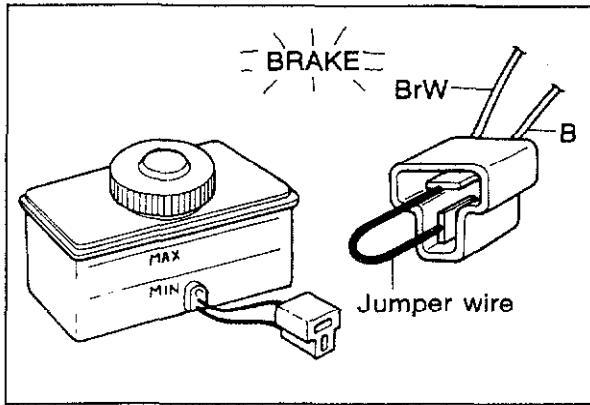

63U15X-050

**INSPECTION OF CIRCUIT AND PARTS**

**Brake System Warning Light**

1. Disconnect the connector from the brake fluid level sensor.
2. Connect a jumper wire between "BrW" and "B" terminal (body ground).
3. Start the engine and check that the BRAKE warning light illuminates.

**Caution**

**Be sure that the parking brake is fully released before checking.**

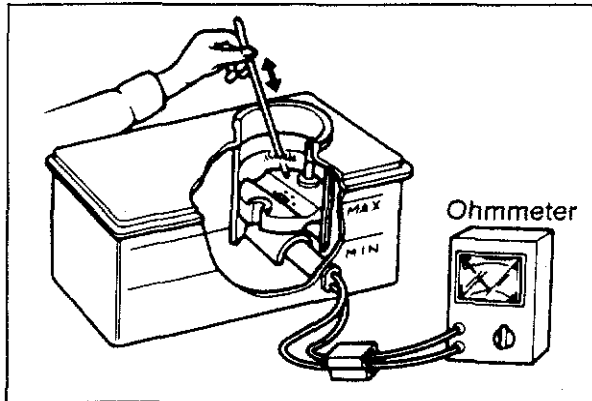

63U15X-051

4. If there is no illumination, check the fuse, bulb and wiring harness.

**Brake Fluid Level Sensor**

Connect an ohmmeter to each terminal of the brake fluid level sensor connector.

Check for continuity when the float is moved up and down. The sensor is good if there is continuity when the float is below the "MIN" mark, and if there is no continuity when the float is above the "MAX" mark. If the sensor does not pass this test, replace it.

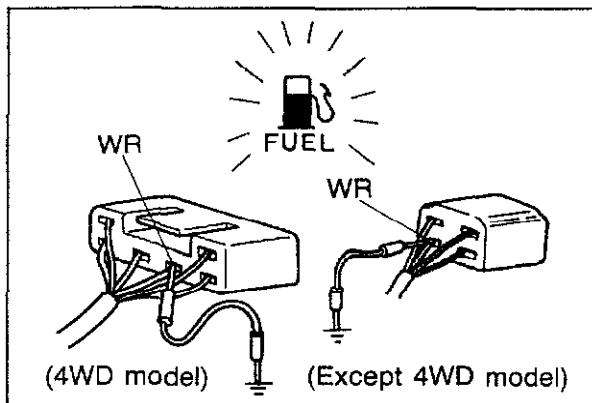

83U15X-034

**Fuel-Level Warning Light**

1. Disconnect the connector from the fuel tank unit.
2. Connect the connector terminal "WR" to the body ground.
3. Start the engine and check that the FUEL warning light illuminates.
4. If there is no illumination, check the fuse, warning light and wiring harness.

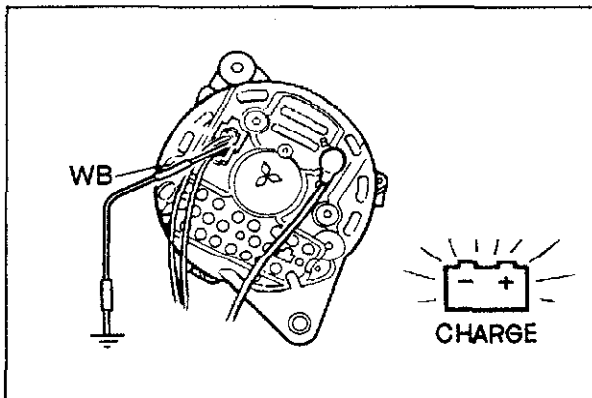

63G15X-021

**Generator Warning Light**

1. Start the engine, connect the connector terminal "WB" to a body ground.
2. Check that the generator warning light illuminates.
3. If there is no illumination, check the warning lights wiring harness and alternator. Replace or repair as necessary.

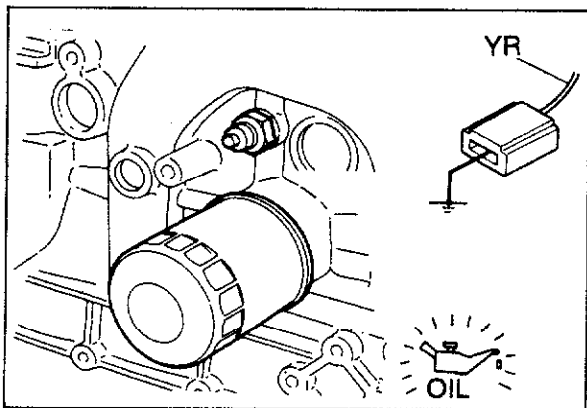

63U15X-054

## Engine Oil Pressure Warning Light

1. Disconnect the connector from the oil pressure switch.
2. Start the engine, connect the connector terminal "YR" to a body ground.
3. Check that the "OIL" warning light illuminates. If it does not illuminate replace sender switch or repair wiring harness, if bulb is not burnt out.

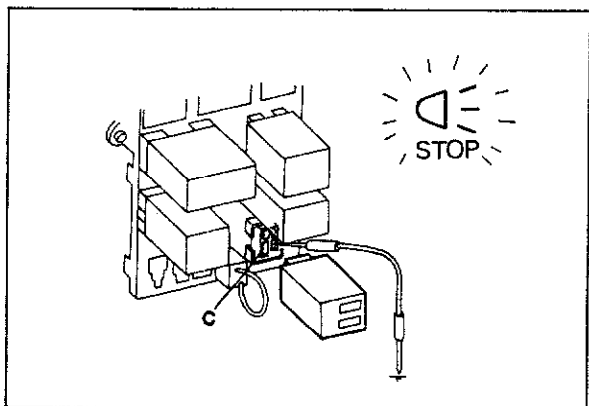

83U15X-035

## Stop Light Malfunction Warning Light

1. Disconnect the connector from the light checker relay.
2. Connect the connector terminal "C" to body ground.
3. Start the engine and check that the STOP LIGHT warning light illuminates. If it does not illuminate and bulb is not burned out, replace switch, or stop light checker, or repair wiring harness. (Also refer to page 15—11, 15—43)

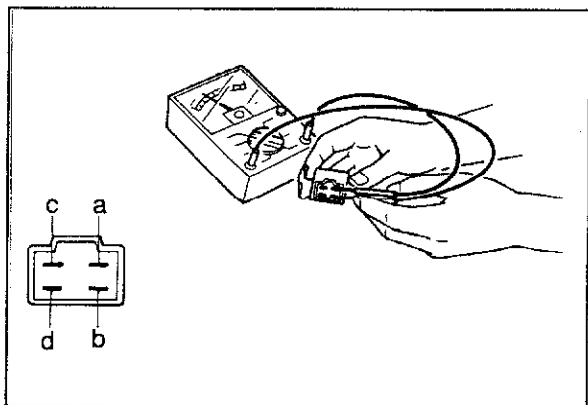

83U15X-036

## Stop Light Checker

1. Check the conductivity between the terminals by using an ohmmeter.

Apply tester red lead to the first mentioned terminal and black lead to the second terminal

a—b	Conductive	b—a	Conductive
a—c	Non-conductive	c—a	Conductive
a—d	Conductive	d—a	Conductive
b—c	Non-conductive	c—b	Conductive
b—d	Conductive	d—b	Conductive
c—d	Conductive	d—c	Non-conductive

## Note

- a) Set the tester to X1000Ω range.
- b) "Conductive" includes state with resistance and "Non conductive" means insulated.

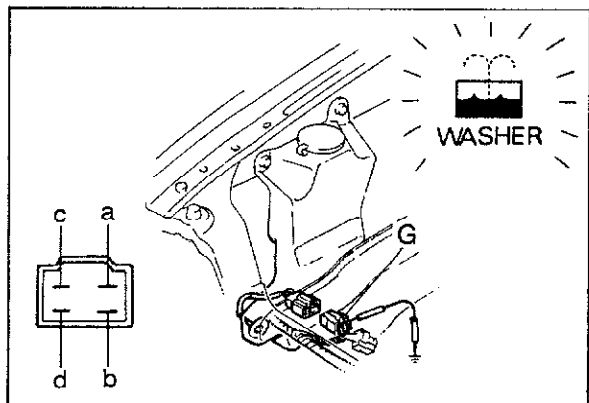

83U15X-037

## Washer Fluid Warning Light

1. Disconnect the connector from the washer fluid level sensor.
2. Start the engine, with a jumper wire connect the connector terminal a (G) to a body ground.
3. Check that the washer fluid warning light illuminates. If it does not illuminate and bulb is not burnt out, replace fluid level sensor or repair wiring harness.

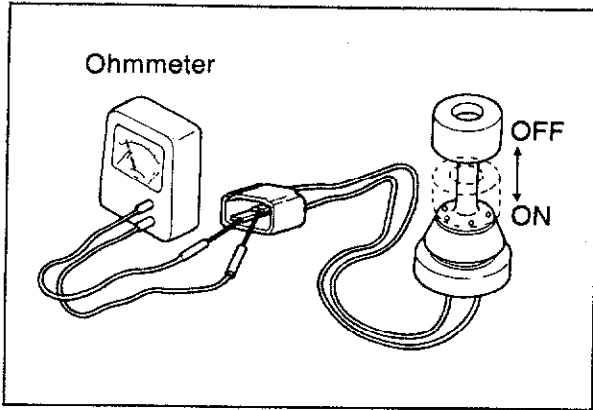

### Washer Fluid Level Sensor

1. Connect the sensor connector to an ohmmeter.
2. Move the sensor float up and down.
3. Check that there is continuity when the float is at the lowest point.

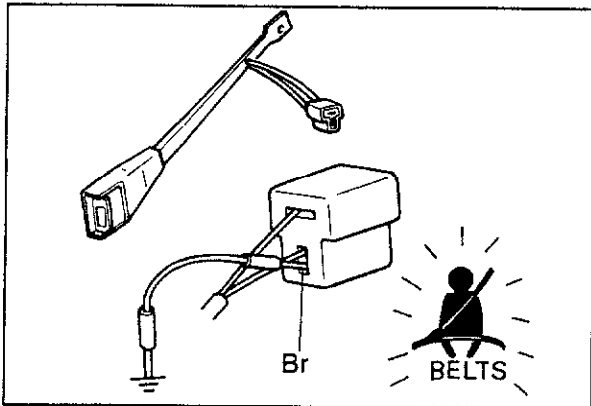

### Seat Belt Warning Light

1. Disconnect the connector from the seat belt buckle switch (driver's side).
2. Connect the connector terminal "Br" to a body ground.
3. Start the engine and check that the BELT warning light illuminates for about 6 seconds.
4. If there is no illumination, check the fuse, warning readout and wiring harness.  
Check bulb, control unit and wiring harness and switch repair or replace as necessary.

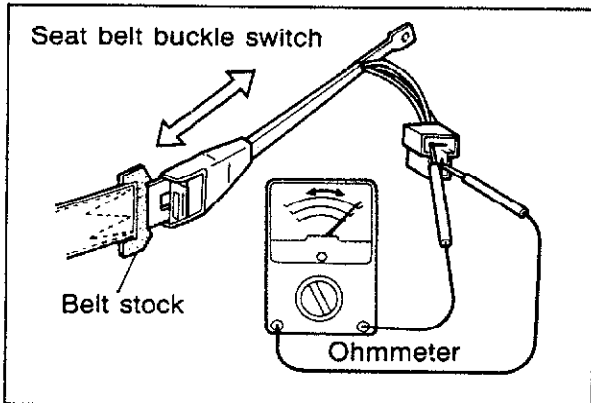

### Buckle Switch (driver's belt)

Insert the seat belt stock into the buckle, and use an ohmmeter to check for continuity of the switch.

- Belt inserted....no continuity
- Belt not inserted....continuity

### Timer and buzzer unit

Check the conductive between the terminals by using an ohmmeter.

Apply tester red lead to the first mentioned terminal and black lead to the second terminal			
c-d	Conductive	h-c	Non-conductive
c-f	Non-conductive	h-d	Non-conductive
c-h	Conductive	h-f	Non-conductive
c-i	Conductive	h-i	Non-conductive
c-d	Conductive	h-j	Non-conductive
d-c	Non-conductive	i-c	Non-conductive
d-f	Non-conductive	i-d	Non-conductive
d-h	Non-conductive	i-f	Non-conductive
d-i	Conductive	i-h	Non-conductive
d-j	Conductive	i-j	Non-conductive
f-c	Non-conductive	j-c	Non-conductive
f-d	Conductive	j-d	Conductive
f-h	Non-conductive	j-f	Non-conductive
f-i	Conductive	j-h	Non-conductive
f-j	Conductive	j-i	Conductive

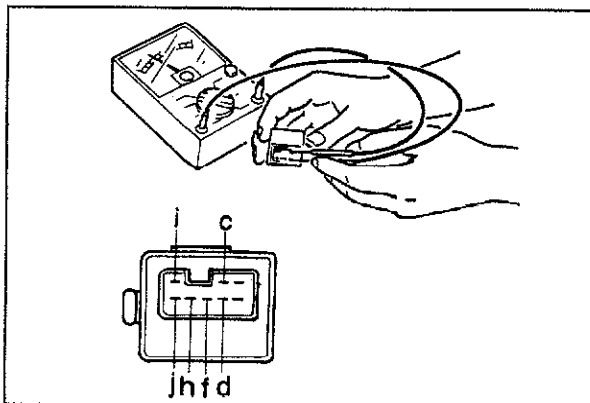

### Note

- Set the tester to  $\times 1000\Omega$  range.
- "Conductive" includes state with resistance and "Non-conductive" means insulated.

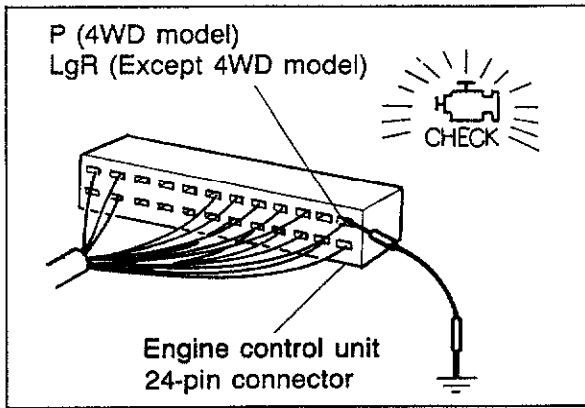

83U15X-039

## Malfunction Indicator Light

1. Connect the "P" (4WD model), "LgR" (Except 4WD model) wire to a body ground.
2. Start the engine and check that the warning light illuminates.
3. If there is no illumination, check meter fuse, bulb and wiring harness between meter and EGI control unit.

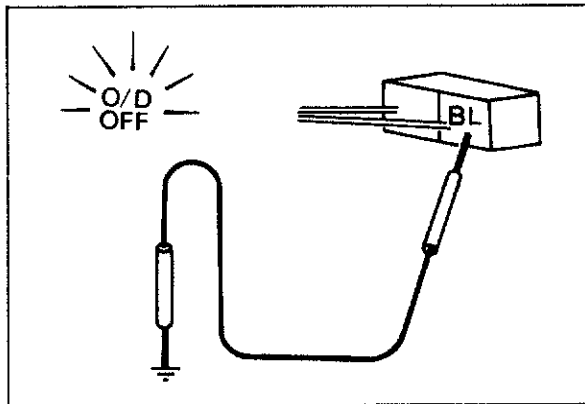

83U15X-040

## Overdrive Off Indicator Light

1. Turn the IGN switch to ON and check that O/D OFF indicator light illuminates when "BL" wire is connected to a body ground.
2. If there is no illumination, check the fuse, warning light, O/D switch and wiring harness. Replace or repair as necessary.

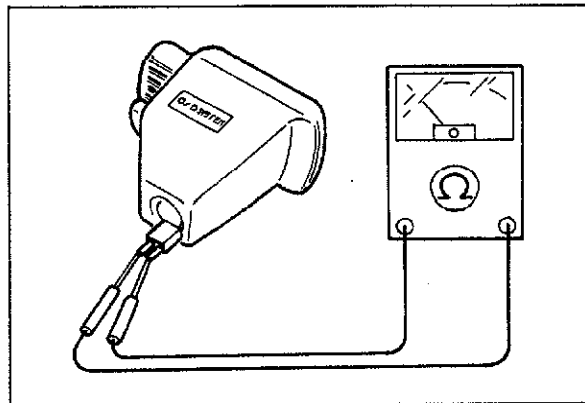

83U15X-041

## O/D Switch

1. Connect an ohmmeter to terminals of the O/D OFF switch.
2. Check for continuity of the switch.

O/D switch	Continuity
Depressed	No
Released	Yes

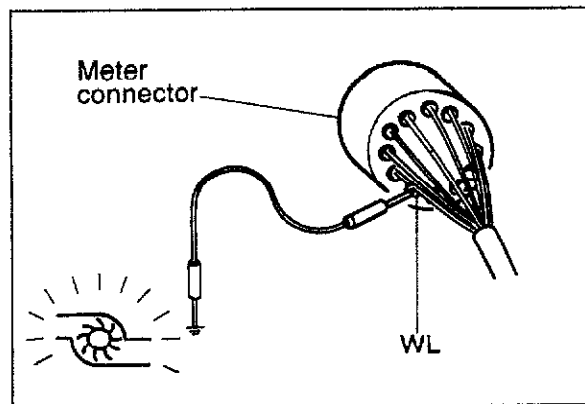

83U15X-042

## Turbo Indicator Light (Turbo Model)

1. Turn the ignition switch to ON.
2. Ground WL wire terminal of meter connector and check that the turbo indicator light illuminates.
3. If it does not illuminate, bulb is burnt out, or faulty printed circuit board.

**LIGHTS REMINDER WARNING**

**STRUCTURAL VIEW**

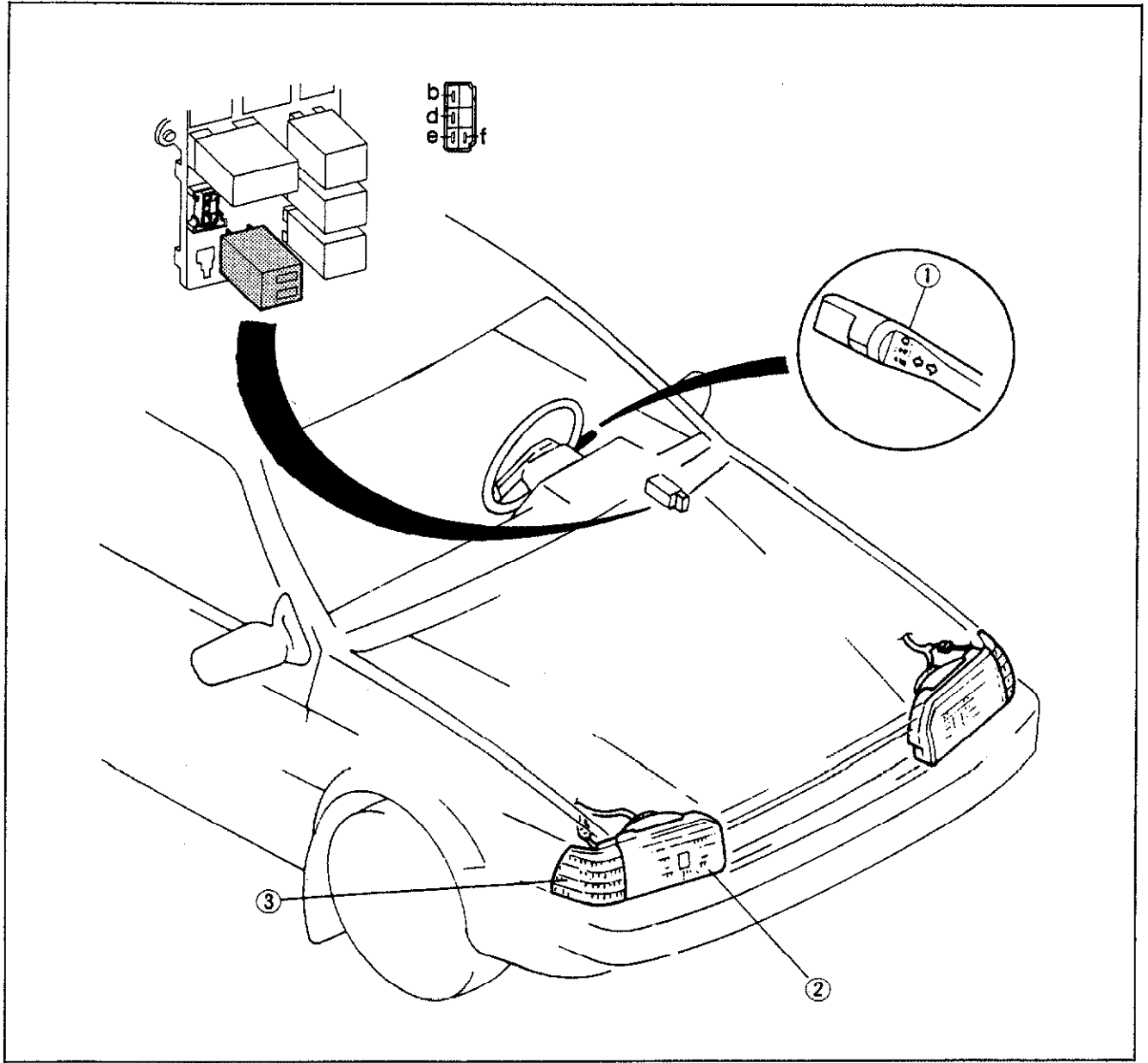

83U15X-043

1. Combination switch

2. Head light







3. Front combination light

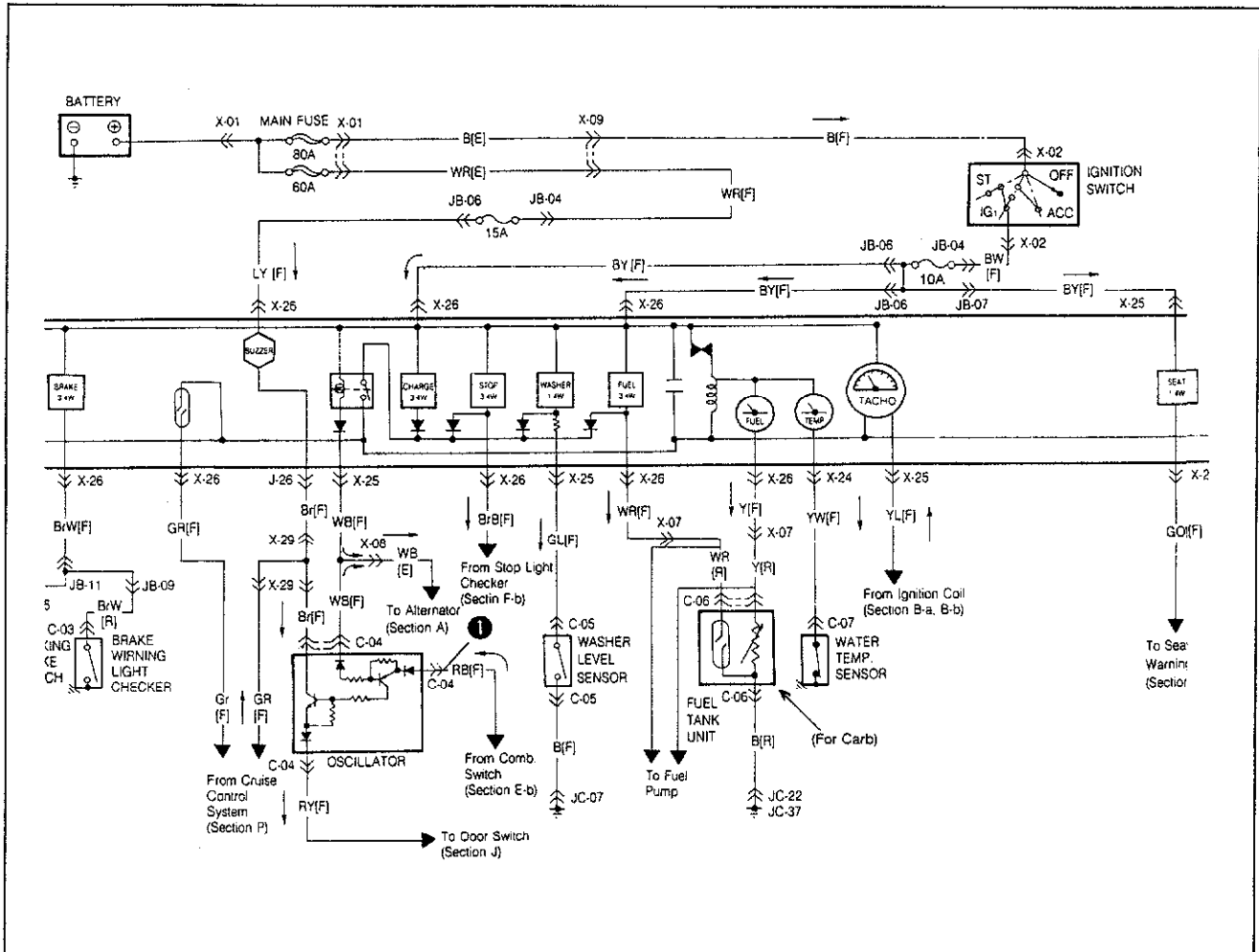

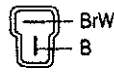
# 15 LIGHTS REMINDER WARNING

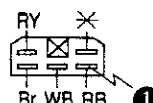
## CIRCUIT DIAGRAM



<p>C-01 Oil Pressure Switch [E]</p>  <p>YR</p>	<p>C-02 Brake Fluid Level Switch [F]</p>  <p>BrW B</p>	<p>C-03 Parking Brake Switch [R]</p>  <p>BrW</p>	<p>C-04 Oscillator [F]</p>  <p>RY Br WB RB</p>
<p>C-05 Washer Fluid Low Level Sensor [F]</p>  <p>GL B</p>	<p>C-06 Fuel Tank Unit [R]</p>  <p>Y WR B (For Carb)</p>	<p>C-07 Water Temp. Sensor [F]</p>  <p>YW</p>	

## TROUBLESHOOTING

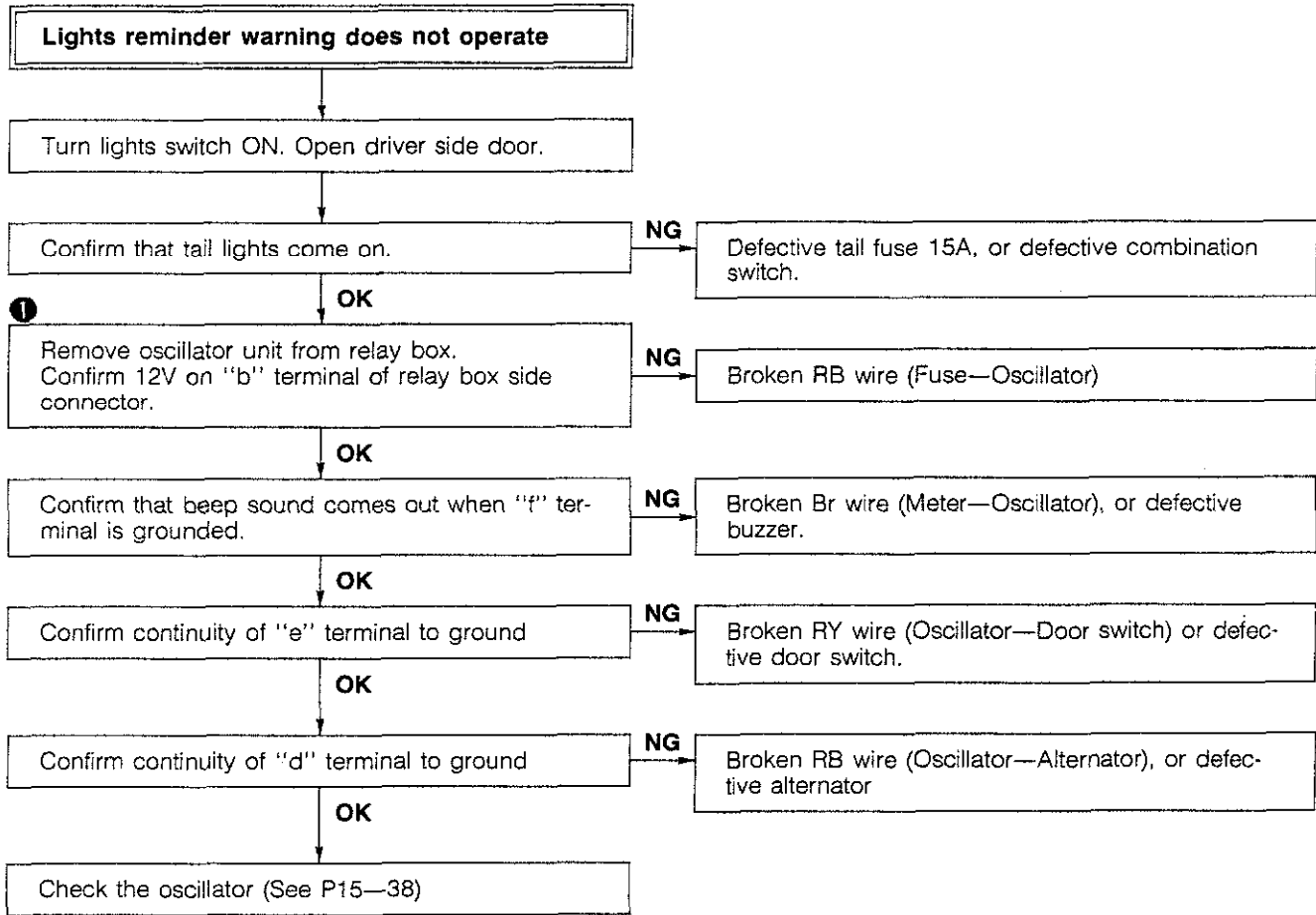

73U15X-024

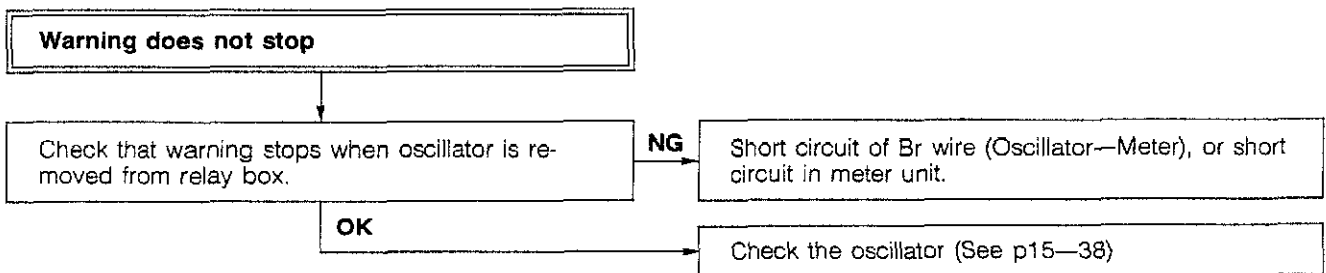

63U15X-062

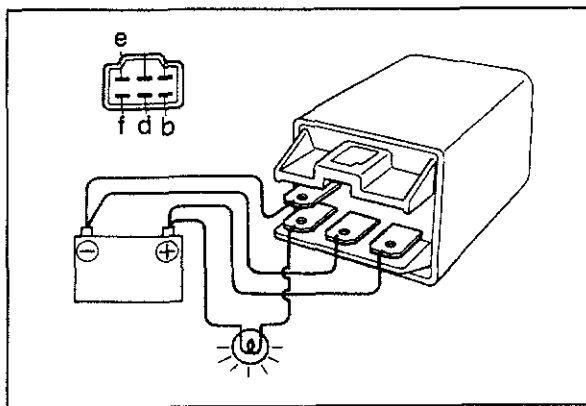

73U15X-025

## OSCILLATOR UNIT

### Operation check

1. Apply 12V to the "b" terminal, and connect "e", "d" terminals to the ground.
2. Confirm that test light comes on when it is connected between the 12V and "f" terminals. Replace oscillator if light does not illuminate.

### Caution

**Do not reverse the polarity (12V power) to the terminals.**

STOP LIGHT

STRUCTURAL VIEW

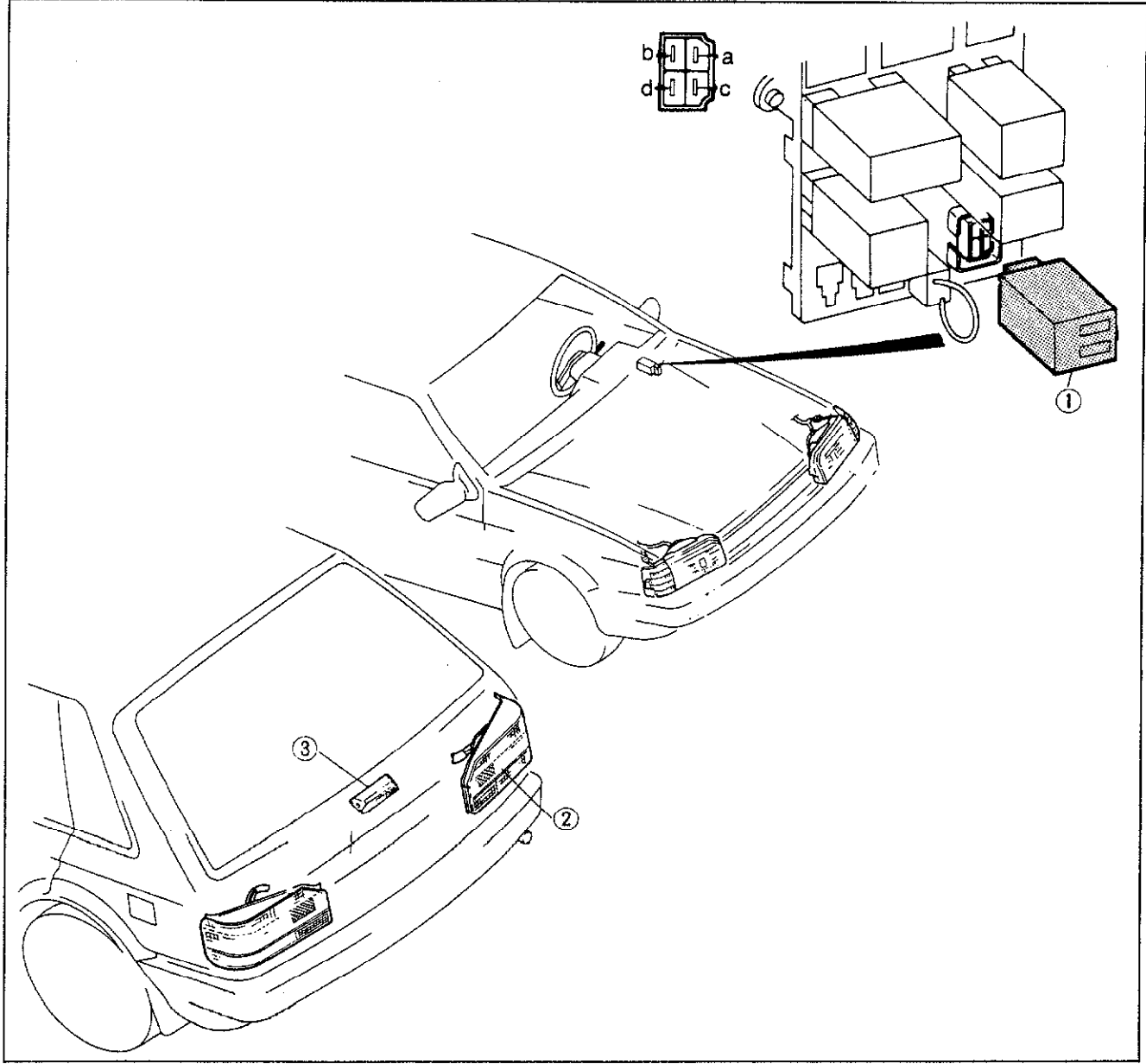

83U15X-045

- 1. Stop light checker relay
- 2. Stop light

- 3. High mounted stop light

# 15 STOP LIGHT

## CIRCUIT DIAGRAM

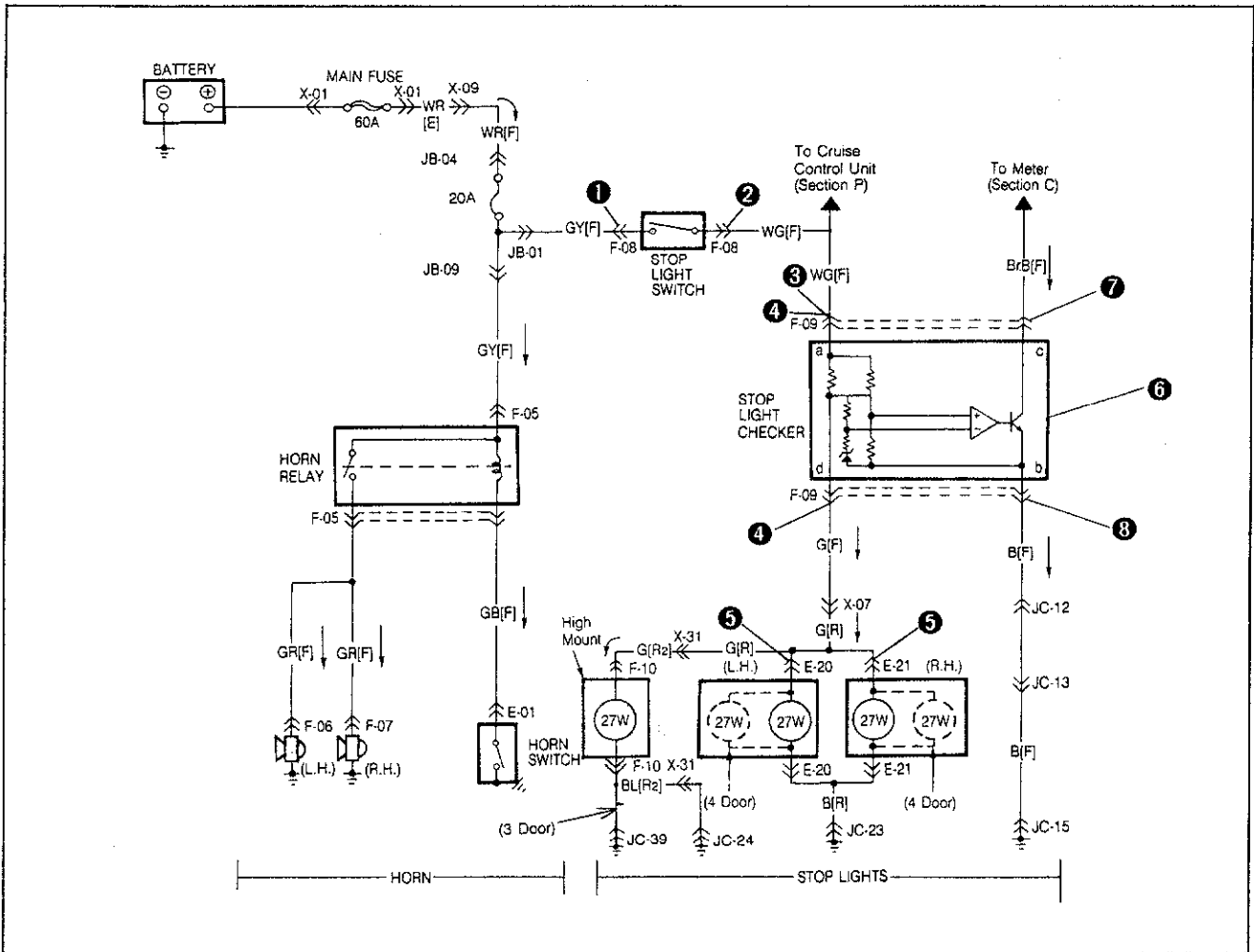

<p>F-05 Horn Relay [F]</p>	<p>F-06 Horn L.H. [F]</p>	<p>F-07 Horn R.H. [F]</p>	<p>F-08 Stop Light Switch [F]</p>
<p>F-09 Stop Light Checker [F]</p>	<p>F-10 High Mounted Stop Light [R2]</p> <p>(3 and 5 Door)</p>	<p>(4 Door)</p>	<p>E-01 Combination Switch [F]</p>
<p>E-20 R. Combi. Light (R.L.) [R]</p>	<p>E-21 R. Combi. Light (R.R.) [R]</p>		

## TROUBLESHOOTING

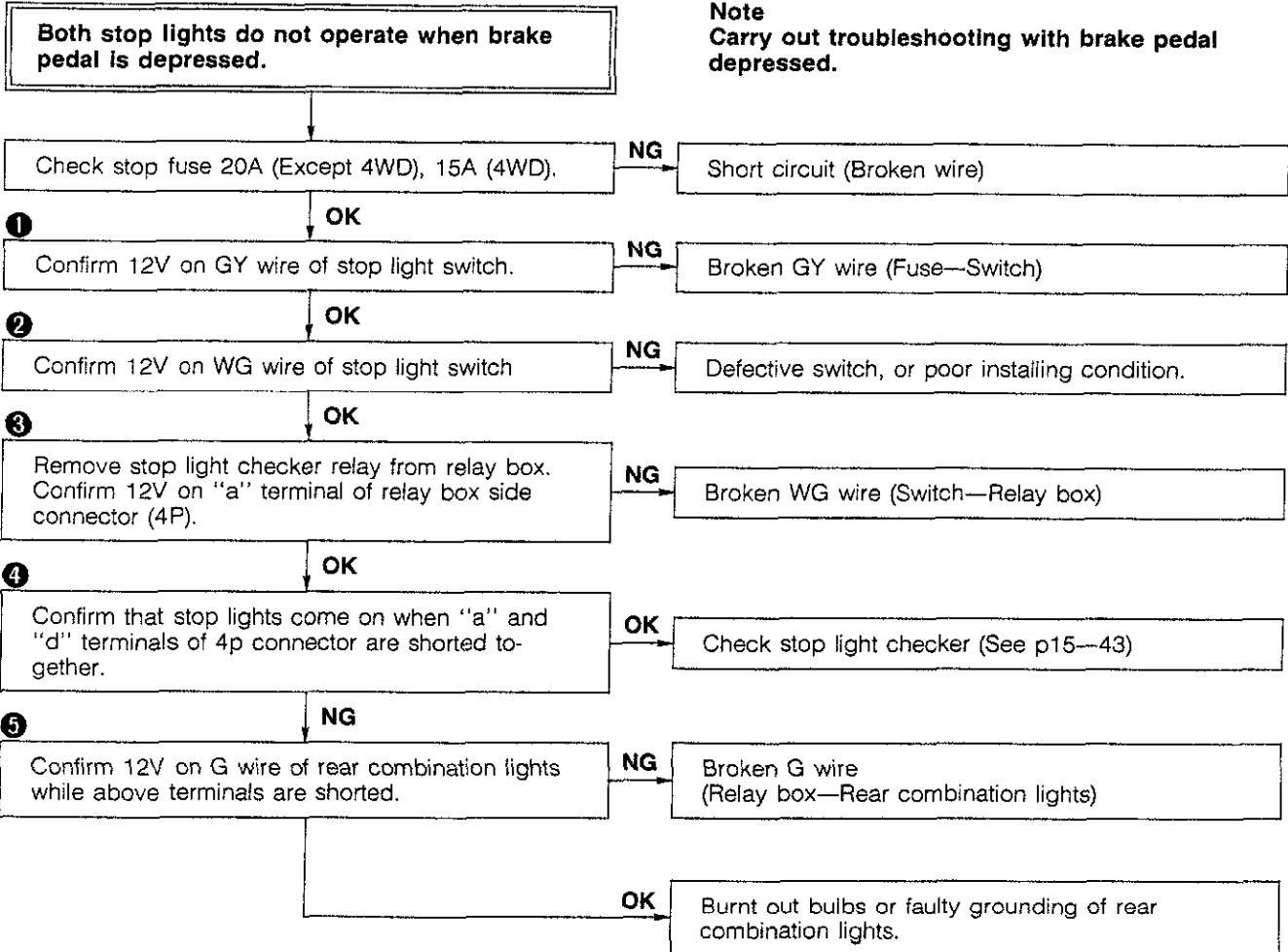

83U15X-047

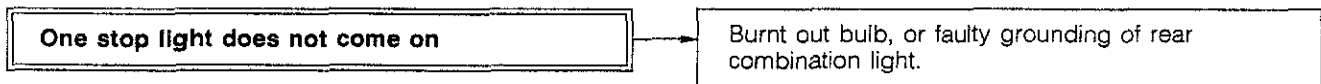

73U15X-028

# 15 STOP LIGHT

**Warning light in meter unit remains on while stop lights operate normally.**

6 With brake pedal depressed, remove light checker unit and confirm that warning light goes off.

NG Short circuit (Broken wire) of BrB wire (Meter—Light checker), or defective meter unit.

OK

Check light checker (See P15—43).

83U15X-048

**Warning light does not come on when stop light bulb is burned out.**

7 Remove light checker from relay box. Confirm that warning light comes on when "c" terminal of relay box side connector is grounded.

NG Broken BrB wire (Meter unit—Light checker), defective meter, or burnt out bulb.

OK

8 Confirm continuity of connector "b" terminal to ground.

NG Faulty grounding of light checker

OK

Defective light checker.

83U15X-049

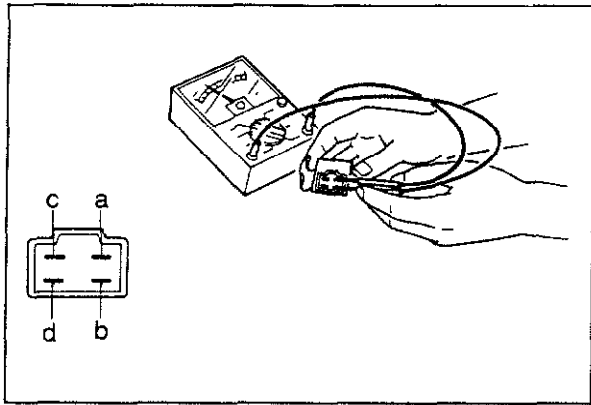

63U15X-073

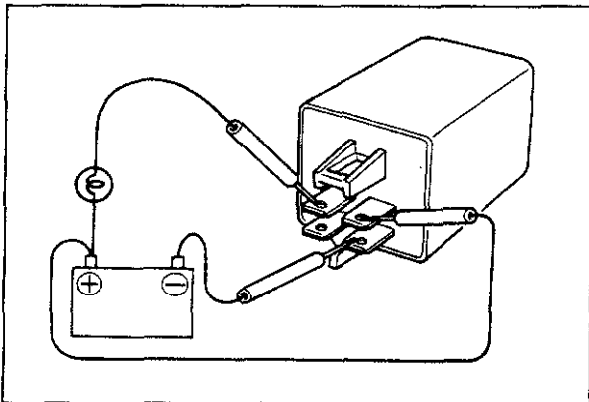

73U15X-031

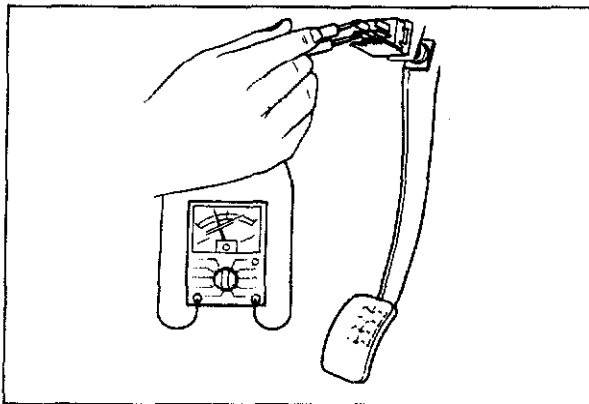

## STOP LIGHT CHECKER

1. Check the conductivity between the terminals by using an ohmmeter.

Apply tester red lead to the first mentioned terminal and black lead to the second terminal

a—b	Conductive	b—a	Conductive
a—c	Non-conductive	c—a	Conductive
a—d	Conductive	d—a	Conductive
b—c	Non-conductive	c—b	Conductive
b—d	Conductive	d—b	Conductive
c—d	Conductive	d—c	Non-conductive

### Note

a) Set the tester to  $X1000\Omega$  range.

b) "Conductive" includes state with resistance and "Non conductive" means insulated.

2. Connect 12V to the "a" terminal and the ground to the "b" terminal. Connect a test light between the 12V and the "c" terminal, and confirm that the test light comes on.
3. Next, confirm that the test light goes off when the 12V is removed from the "a" terminal.

### Note

Do not misconnect or reverses the polarity of the power source to the terminals.

## STOP LIGHT SWITCH

1. Disconnect the 2 Pin connector from the switch.
2. Confirm the conductivity between the two terminals of the stop light switch.



# 15 TURN AND HAZARD SIGNAL LIGHT

## TURN AND HAZARD SIGNAL LIGHT

### STRUCTURAL VIEW

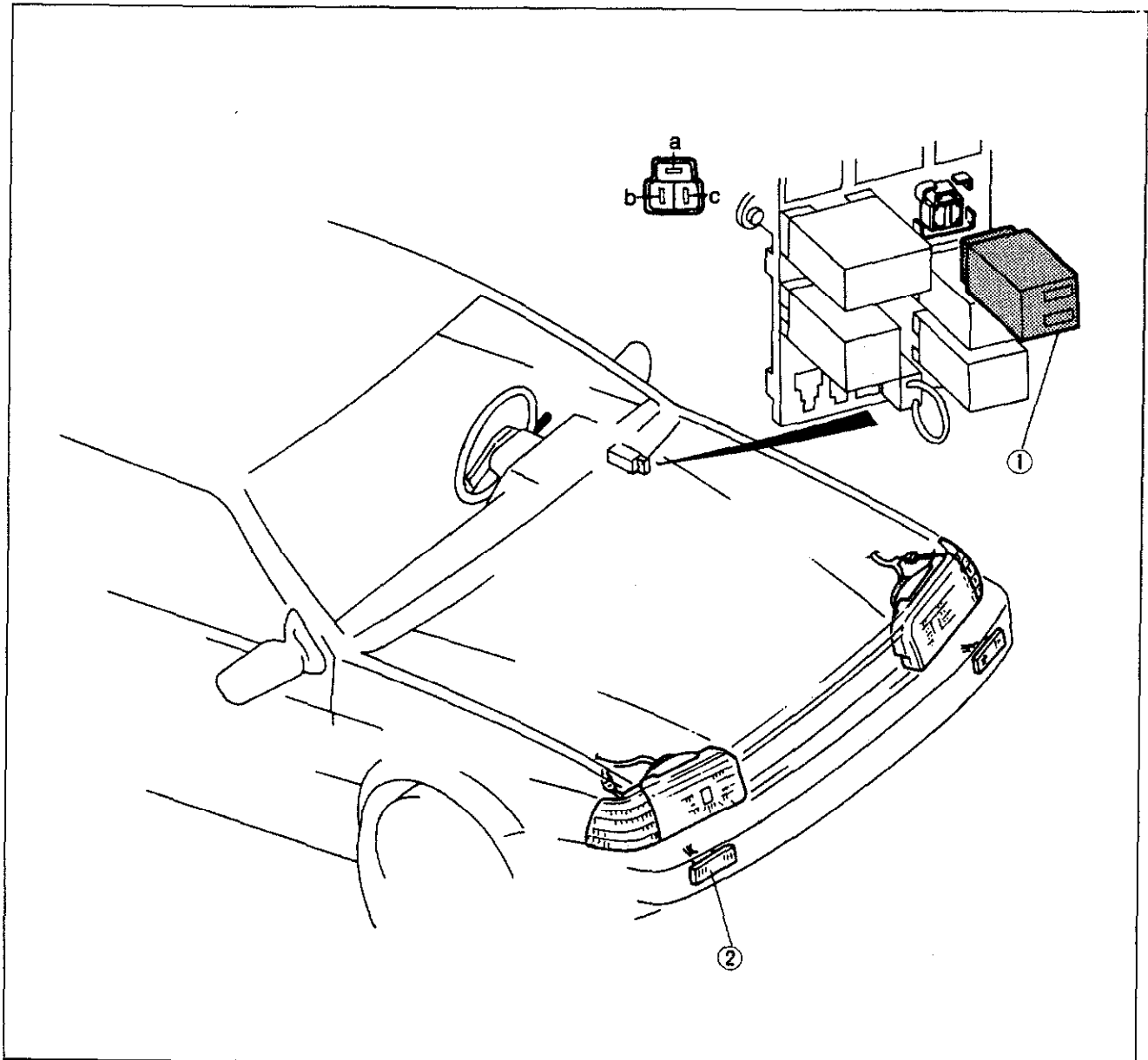

83U15X-050

1. Flasher unit

2. Turn and hazard signal light

## CIRCUIT DIAGRAM

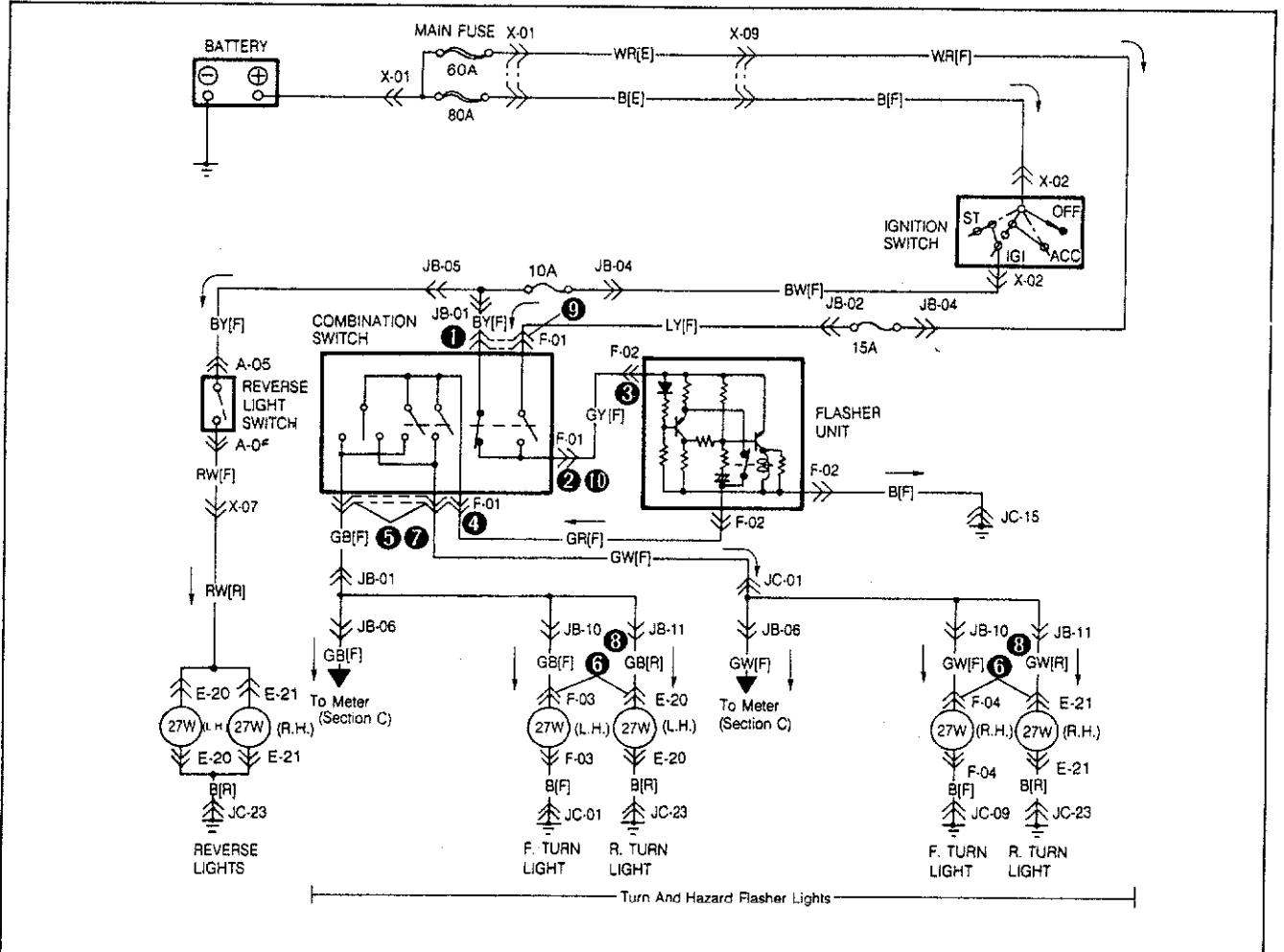

<p>F-01 Combination Switch [F]</p>	<p>F-02 Flasher Unit [F]</p>	<p>F-03 Front Turn F.L. [F]</p>	<p>F-04 Front Turn F.R. [F]</p>
<p>A-05 Reverse Light Switch [F]</p>	<p>E-20 Rear Combi. Light R.L. [R]</p>	<p>E-21 Rear Combi. Light R.R. [R]</p>	

# 15 TURN AND HAZARD SIGNAL LIGHT

## TROUBLESHOOTING

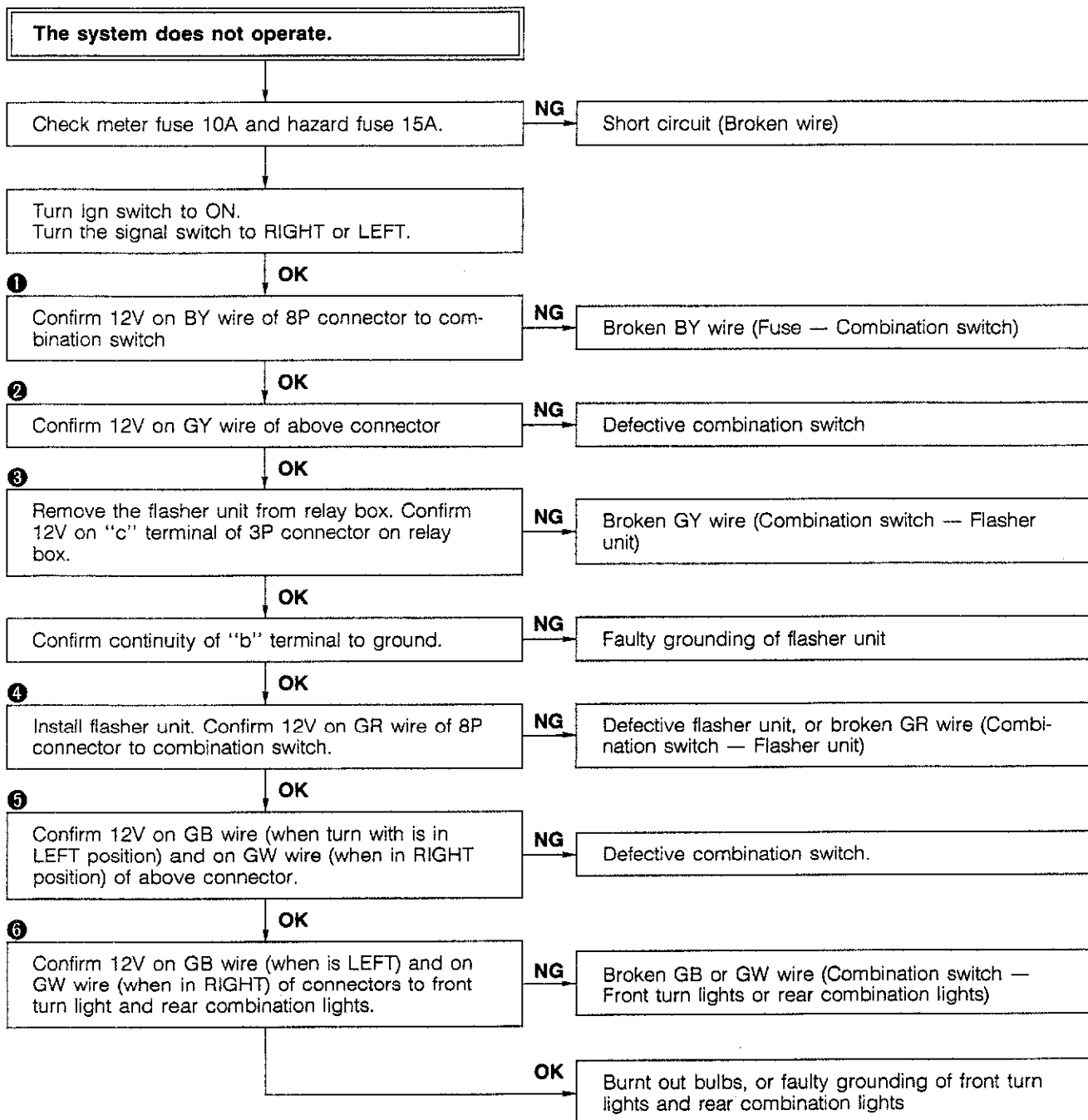

83U15X-052

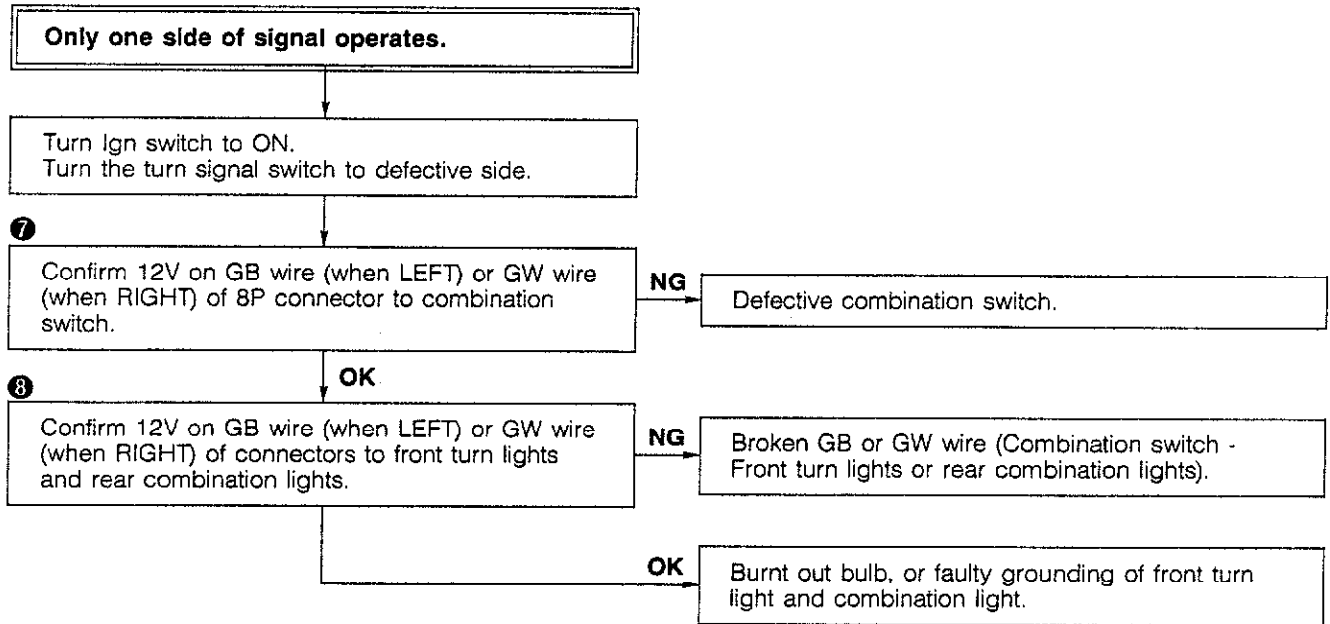

83U15X-053

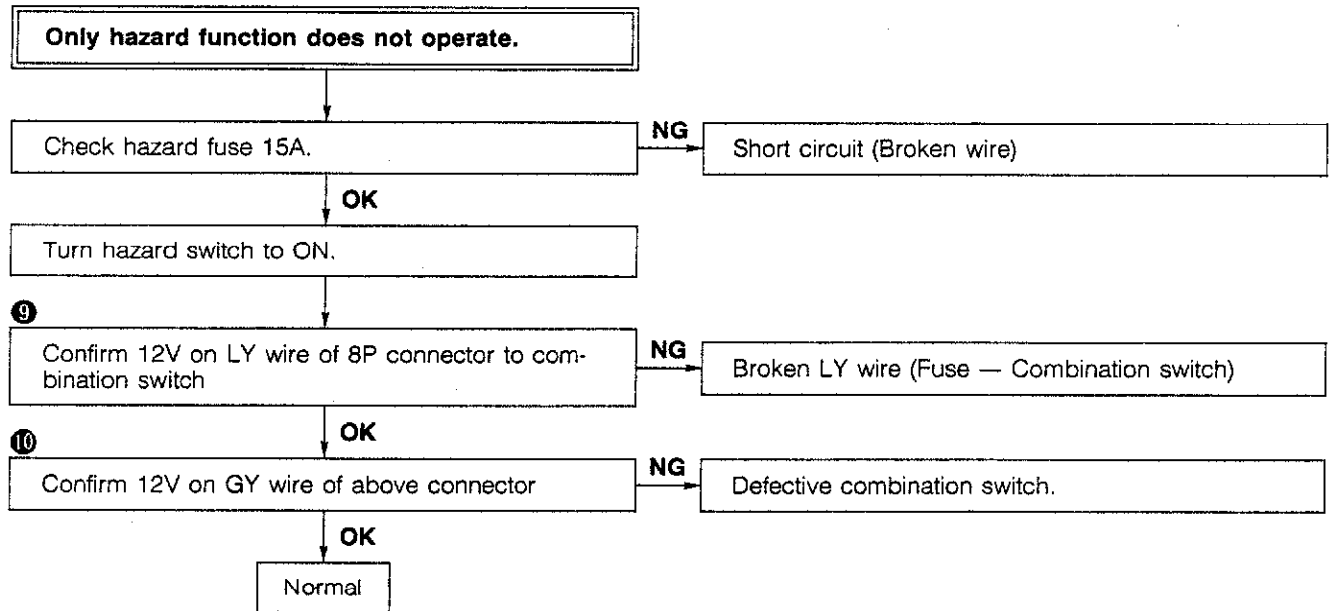

83U15X-054

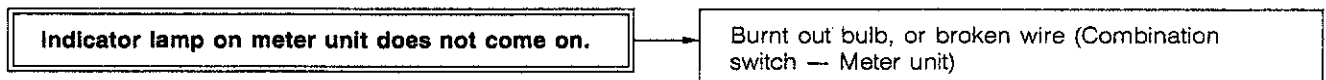

73U15X-036

# 15 TURN AND HAZARD SIGNAL LIGHT

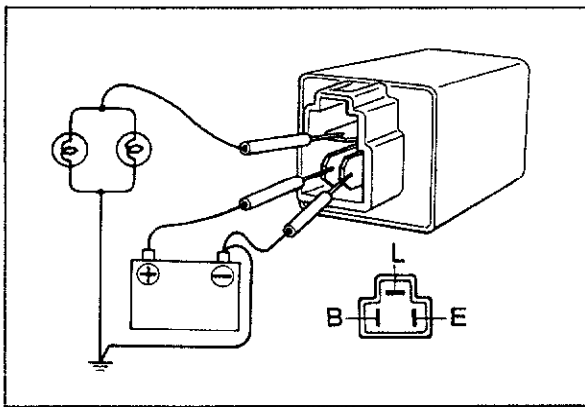

73U15X-037

## FLASHER UNIT

### Operation check

1. Apply 12V to the "B" terminal of the unit and connect "E" terminal to the ground.
2. Confirm that the two paralleled lamps come on when connected between the "L" terminal and the ground.

### Caution

**Do not reverse the polarity of the electrical source to the terminals.**

ILLUMINATED ENTRY SYSTEM

STRUCTURAL VIEW

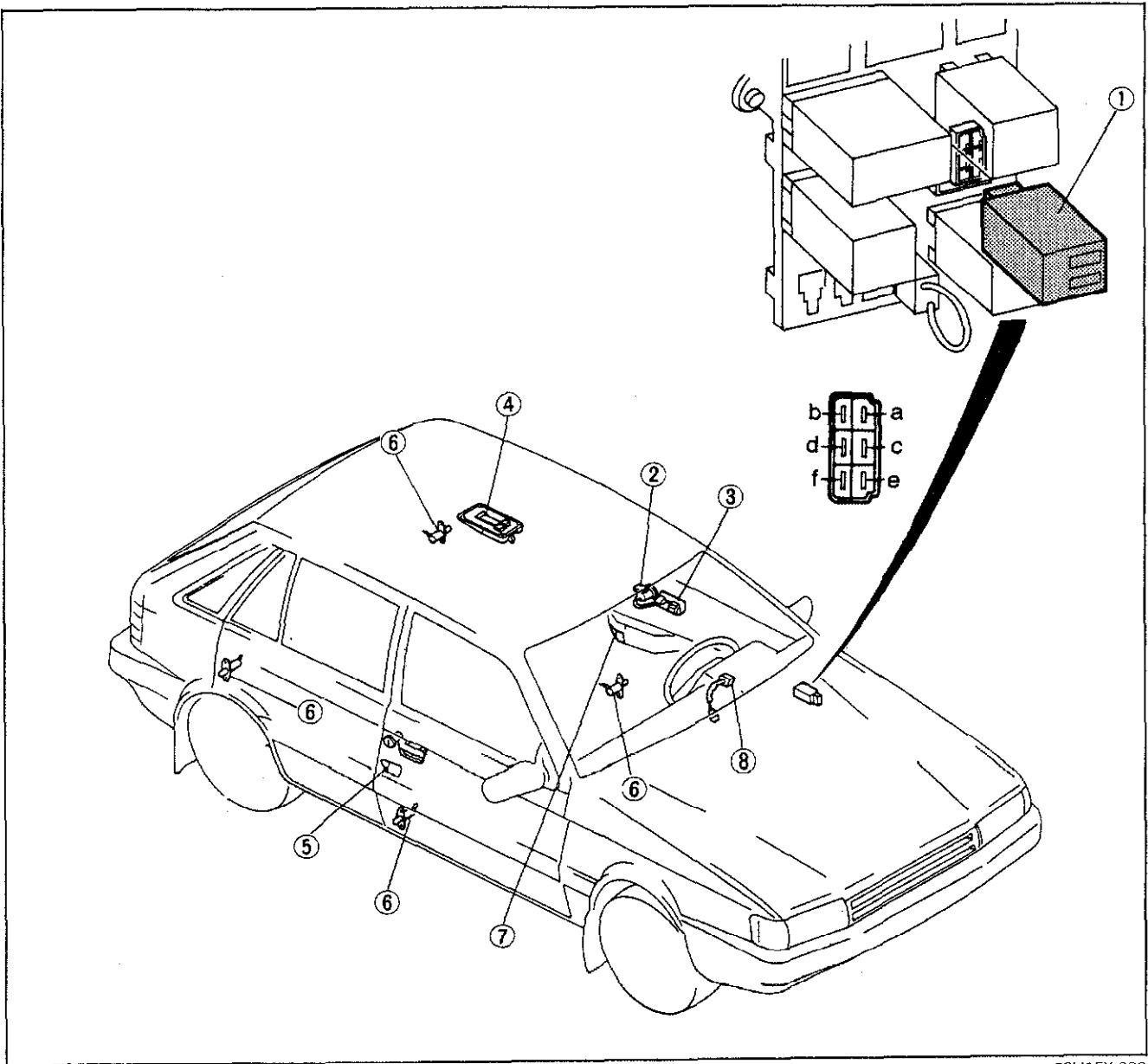

63U15X-082

- 1. Entry timer unit
- 2. Door key illumination
- 3. Door handle

- 4. Interior light
- 5. Courtesy light
- 6. Door switch

- 7. Courtesy light
- 8. IG. key illumination

# 15 ILLUMINATION ENTRY SYSTEM

## CIRCUIT DIAGRAM

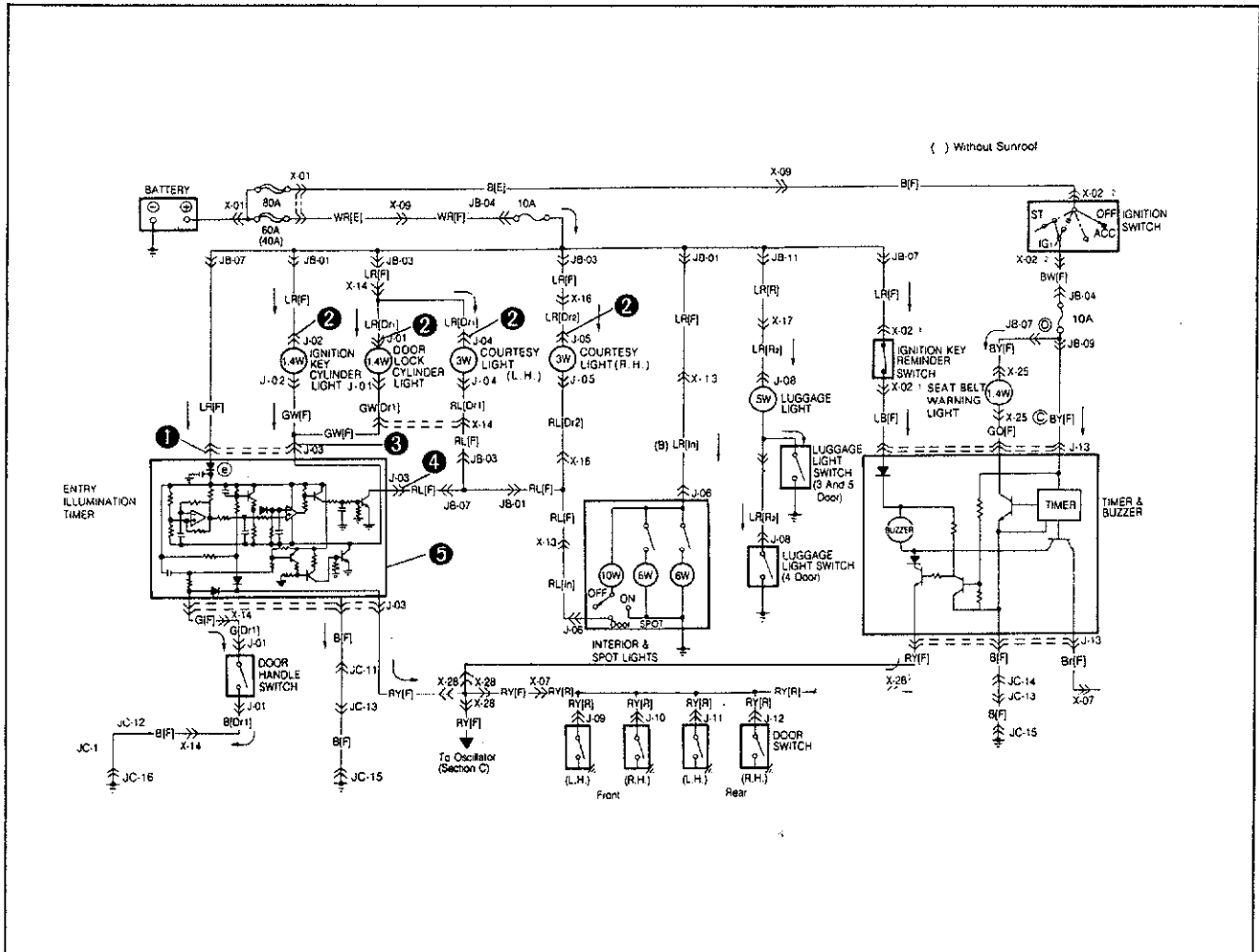

<p>J-01 Door Lock Cylinder Light And Door Handle Switch [Dr1]</p>	<p>J-02 IG Key Cylinder Light [F]</p>	<p>J-03 Entry Illumination Timer [F]</p>	<p>J-04 Courtesy Light L.H. [Dr1]</p>
<p>J-05 Courtesy Light R.H. [Dr2]</p>	<p>J-06 Interior And Spot Lights [In]</p>	<p>J-07 Luggage Compartment Light [Rz]</p>	
<p>J-08 Luggage Compartment Light Switch [Rz]</p>	<p>J-09 Door Switch F.L. [R]</p>	<p>J-10 Door Switch F.R. [R]</p>	<p>J-11 Door Switch R.L. [R]</p>
<p>J-12 Door Switch R.R. [R]</p>	<p>J-13 Timer And Buzzer [F]</p>	<p>J-14 Seat Belt Switch [R]</p>	

## TROUBLESHOOTING

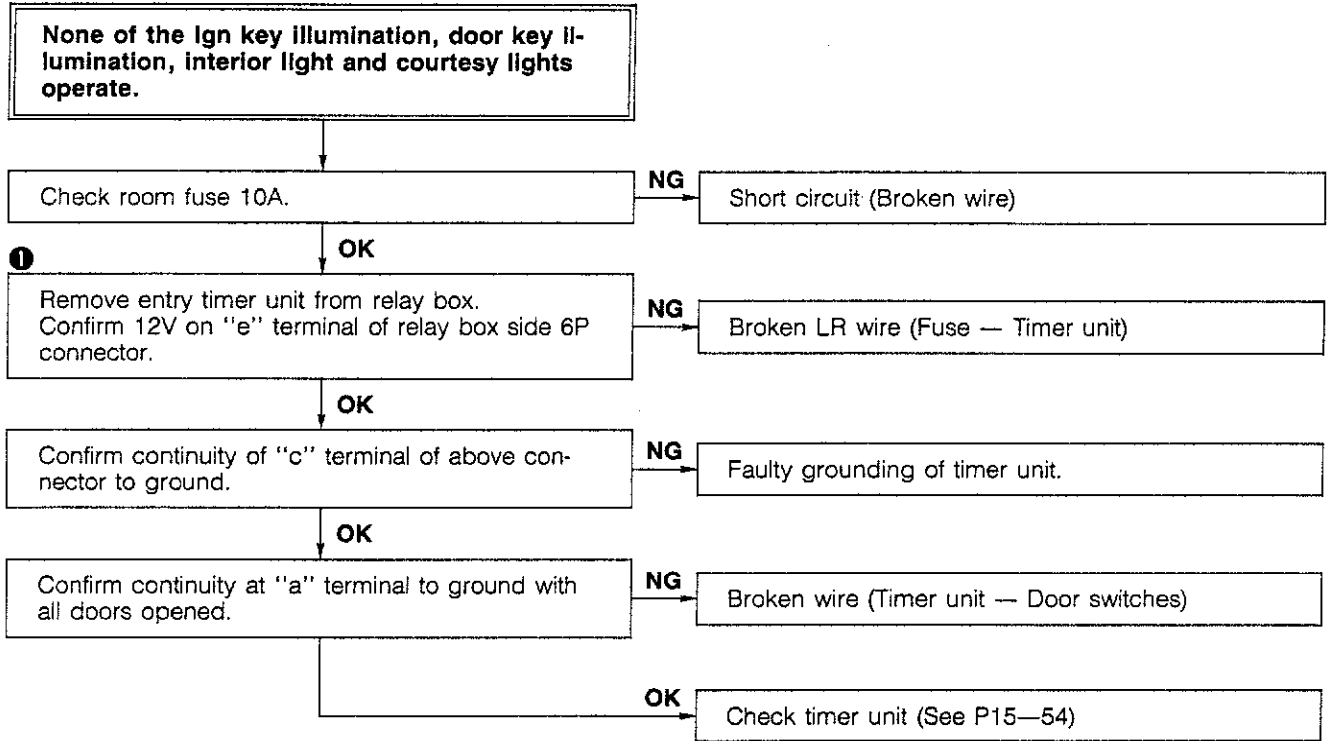

83U15X-056



# 15 ILLUMINATED ENTRY SYSTEM

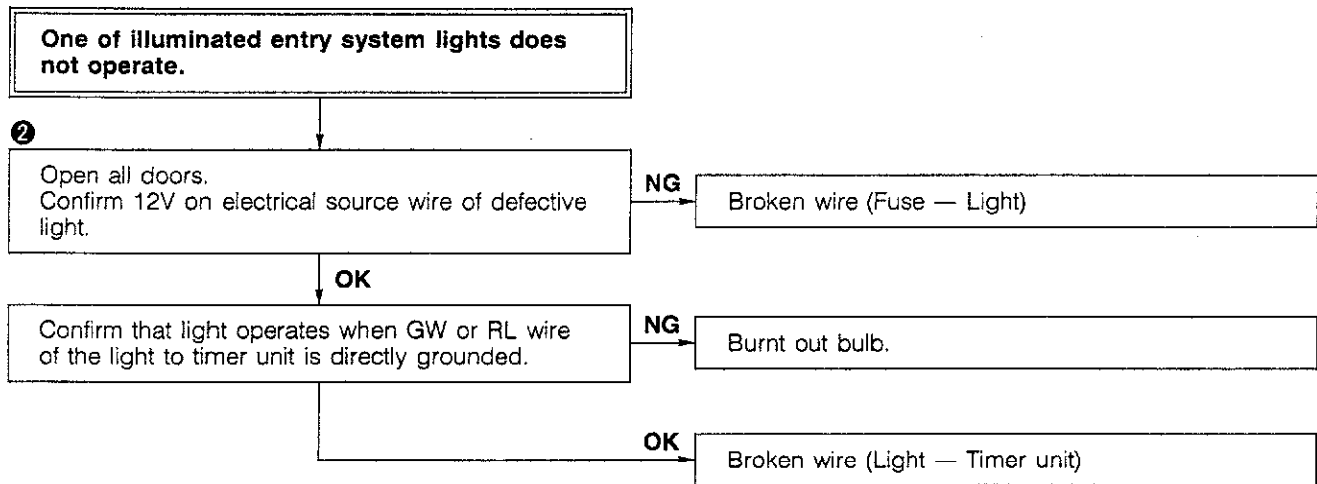

83U15X-057

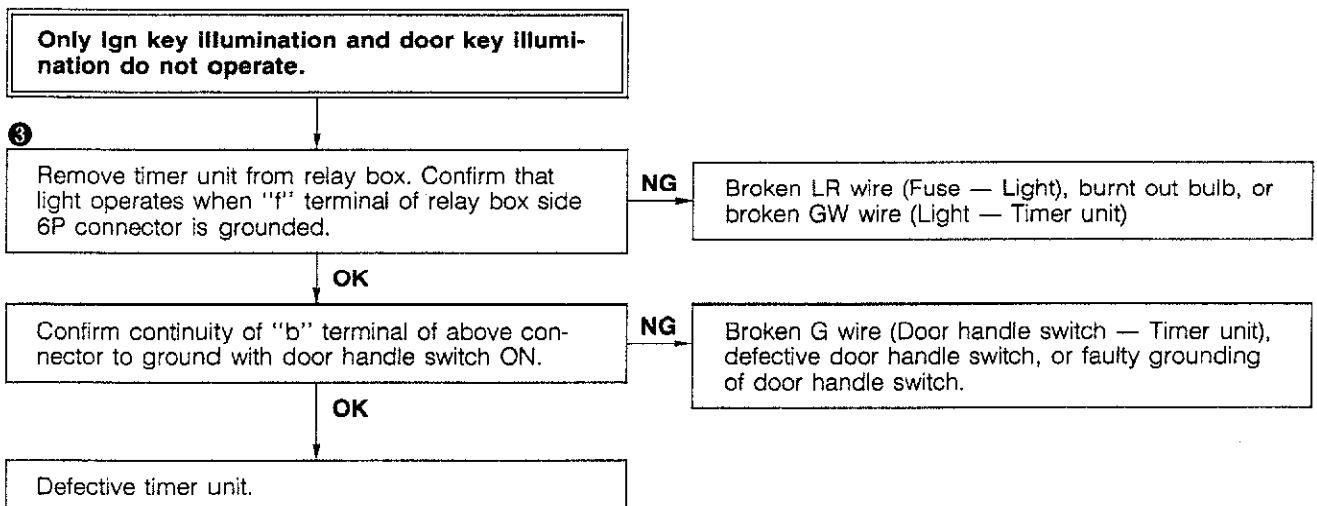

83U15X-058

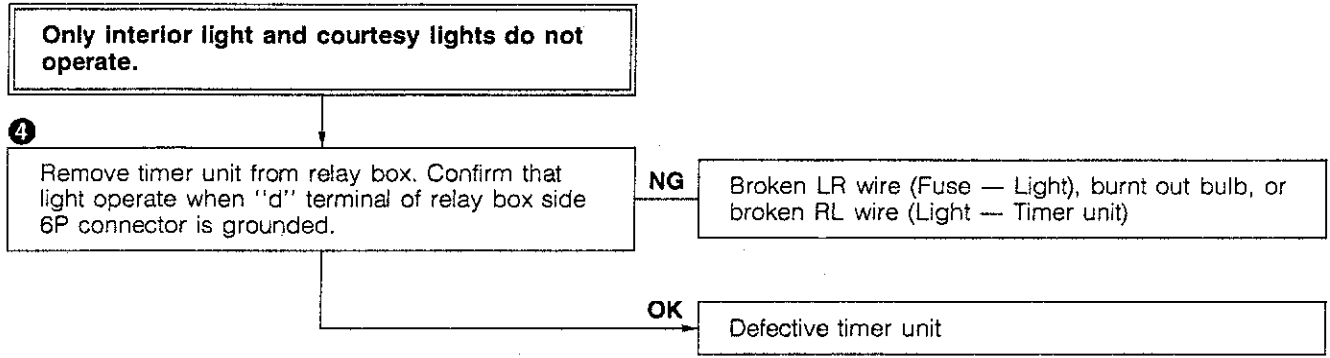

83U15X-059

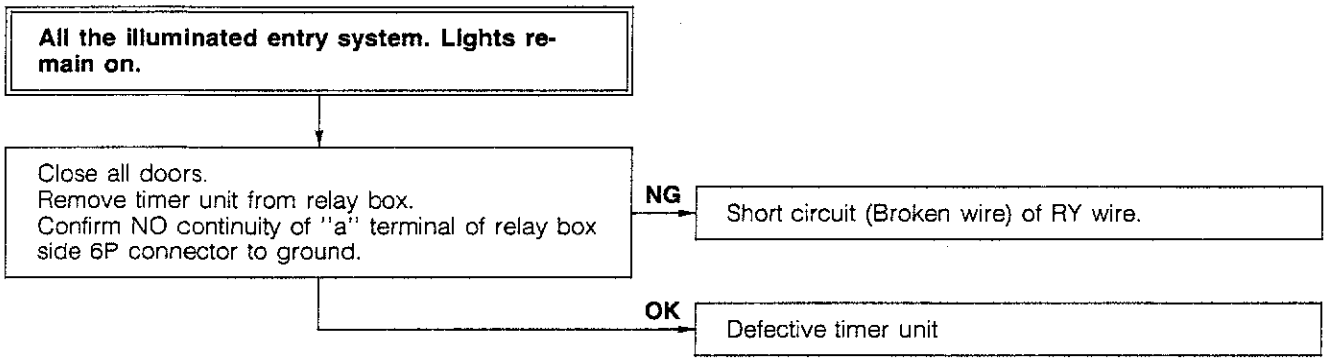

73U15X-042

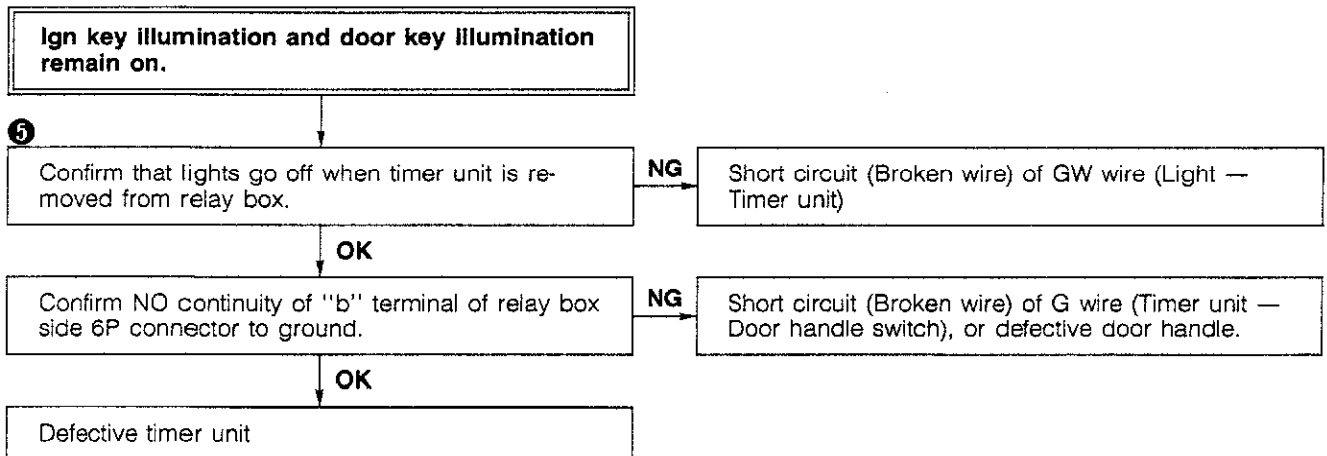

83U15X-060

# 15 ILLUMINATED ENTRY SYSTEM

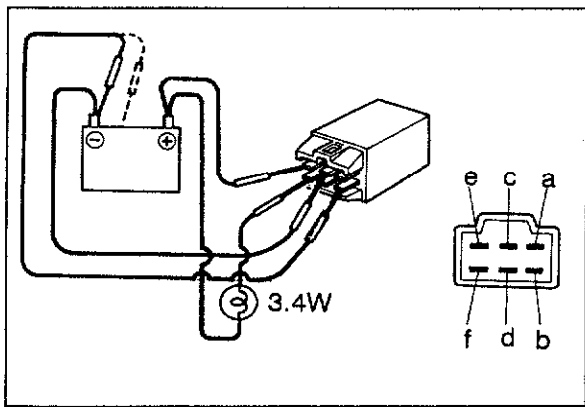

73U15X-044

## TIMER UNIT

### Checking the operation of key illumination control

1. Connect the 12V to the "e" terminal and the ground to the "c" terminal.
2. Connect a 3.4W test light between the 12V and the "f" terminal.
3. Confirm that the test light glows when the "b" terminal is grounded and goes off about 5 seconds after the "b" terminal is separated from the ground.

#### Note

**Do not connect the electrical source to other terminals.**

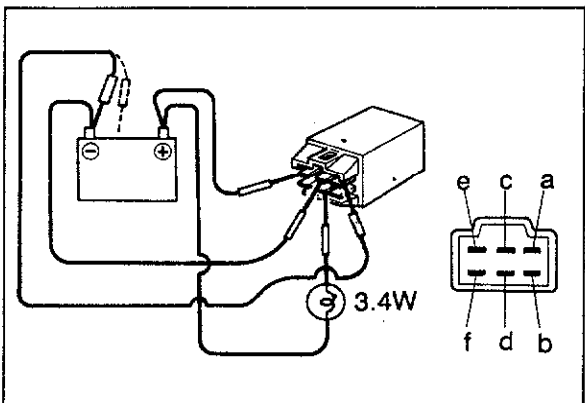

73U15X-045

### Checking the operation of interior light control

1. Connect the 12V to the "e" terminal and the ground to the "c" terminal.
2. Connect a 3.4W test light between the 12V and the "d" terminal.
3. Confirm that the test light glows when the "a" terminal is grounded and gradually goes off when the "b" terminal is separated from the ground.

#### Note

**Do not connect the electrical source to other terminals.**

HORN

STRUCTURAL VIEW

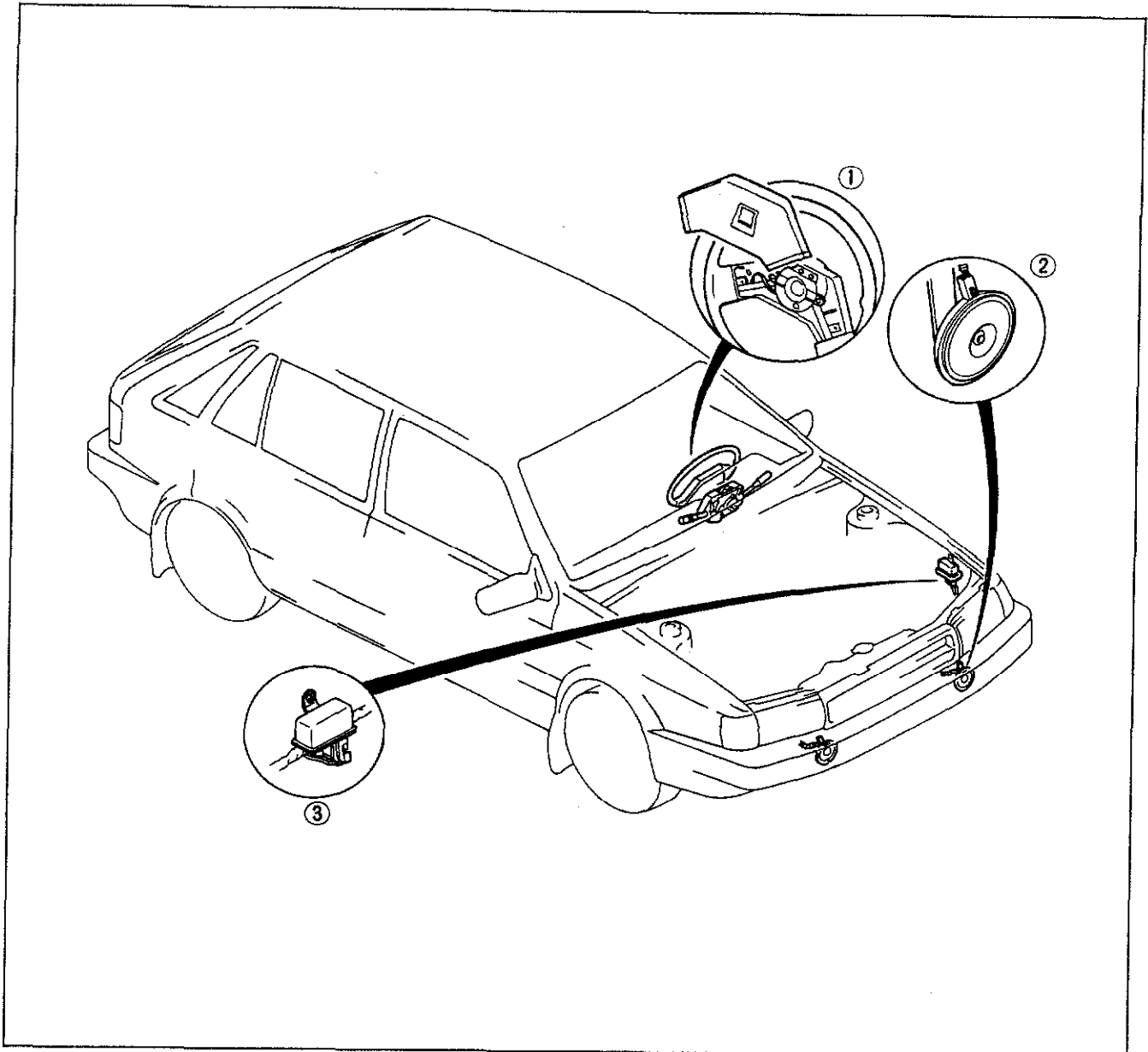

63U15X-094

1. Horn switch

2. Horn

3. Horn relay

## CIRCUIT DIAGRAM

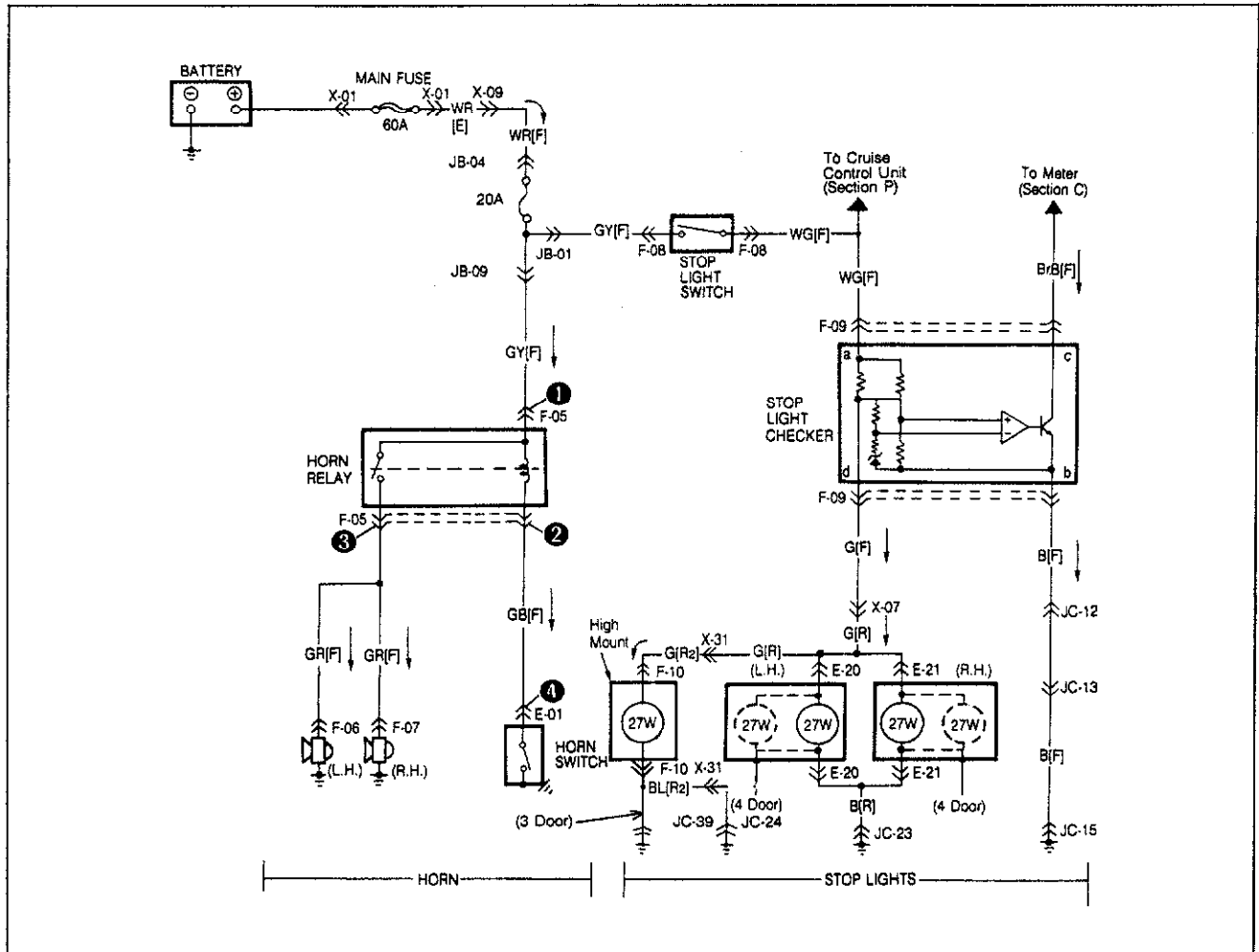

<p>F-05 Horn Relay [F]</p>	<p>F-06 Horn L.H. [F]</p>	<p>F-07 Horn R.H. [F]</p>	<p>F-08 Stop Light Switch [F]</p>
<p>F-09 Stop Light Checker [F]</p>	<p>F-10 High Mounted Stop Light [R2]</p> <p>(3 and 5 Door)</p>	<p>(4 Door)</p>	<p>E-01 Combination Switch [F]</p>
<p>E-20 R. Combi. Light (R.L.) [R]</p>	<p>E-21 R. Combi. Light (R.R.) [R]</p>		

## TROUBLESHOOTING

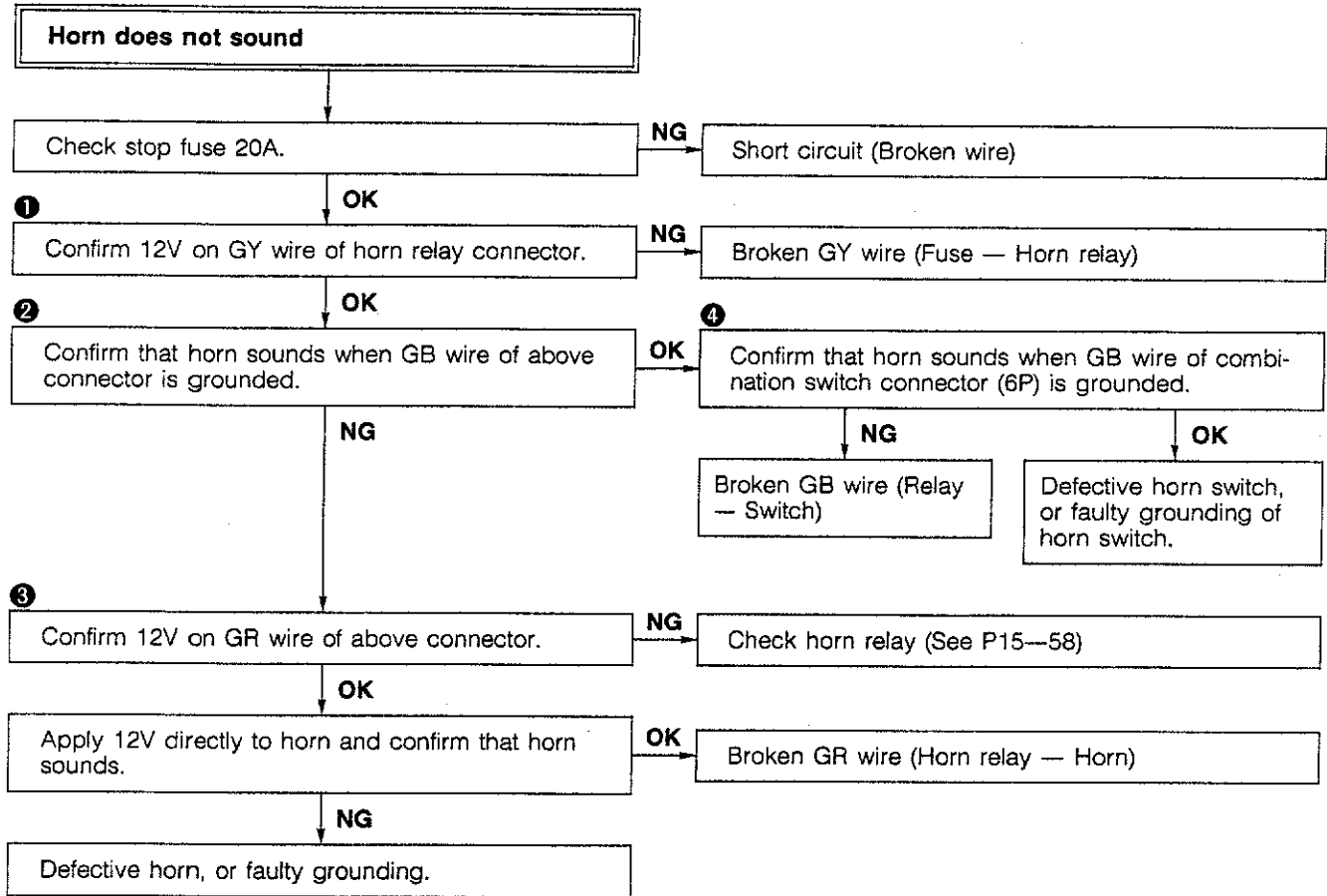

83U15X-062

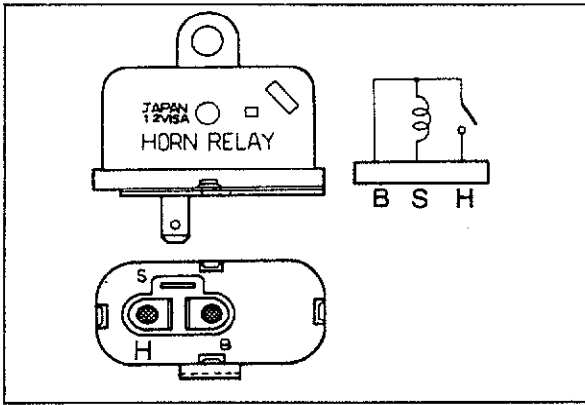

83U15X-063

## INSPECTION

### Horn Relay

1. Confirm the continuity between the B and S terminals.
2. Connect the 12V to the B terminal and the ground to the S terminal, and then confirm 12V on R terminal.

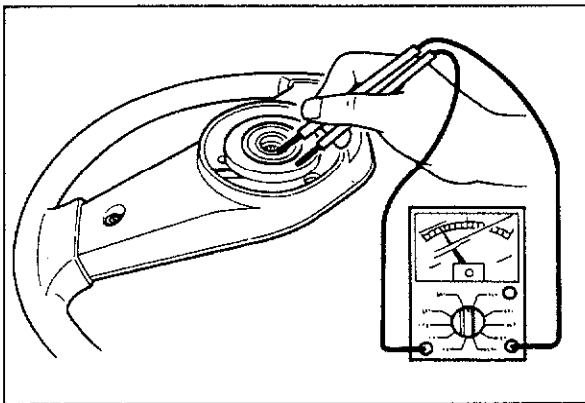

83U15X-064

### Horn Switch

1. Confirm the continuity between the horn conductor plate and the serration gear part when the horn switch is pushed ON.

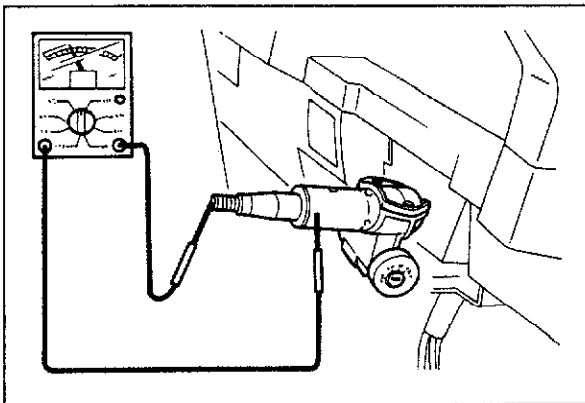

63U15X-099

2. Confirm the continuity between the steering shaft and the shaft case.

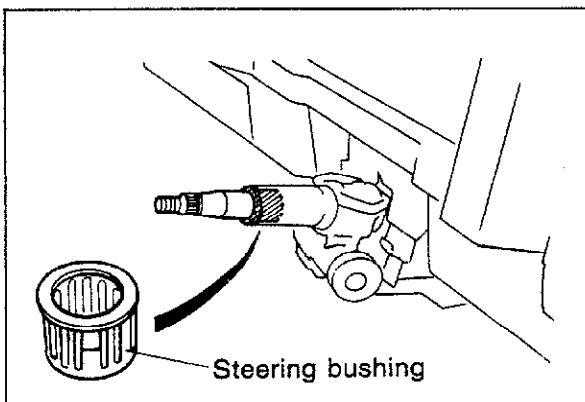

63U15X-100

3. If there is no continuity in above check, replace the steering bushing.

## HEADLIGHT CIRCUIT DIAGRAM

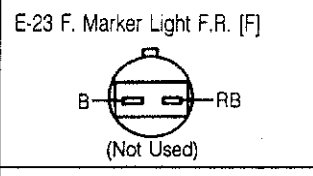
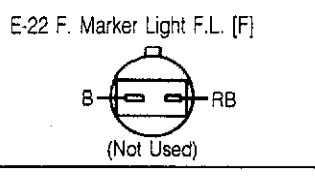
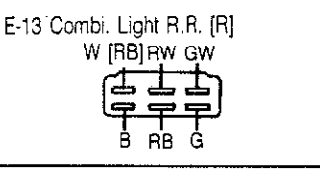
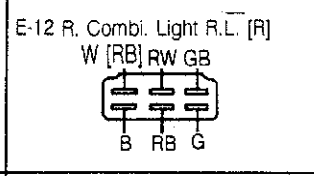
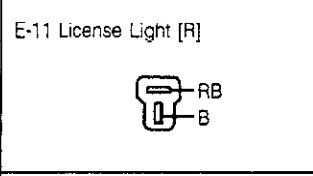
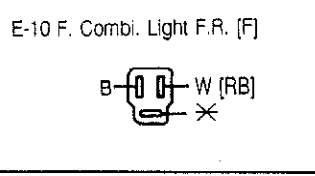
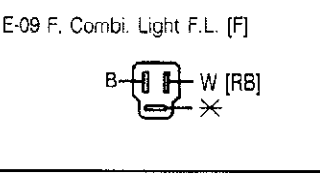
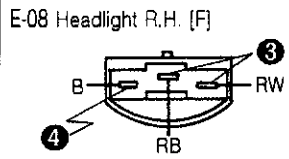
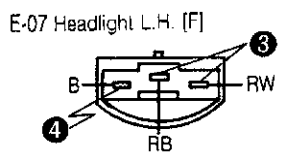
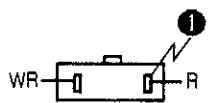
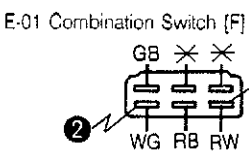
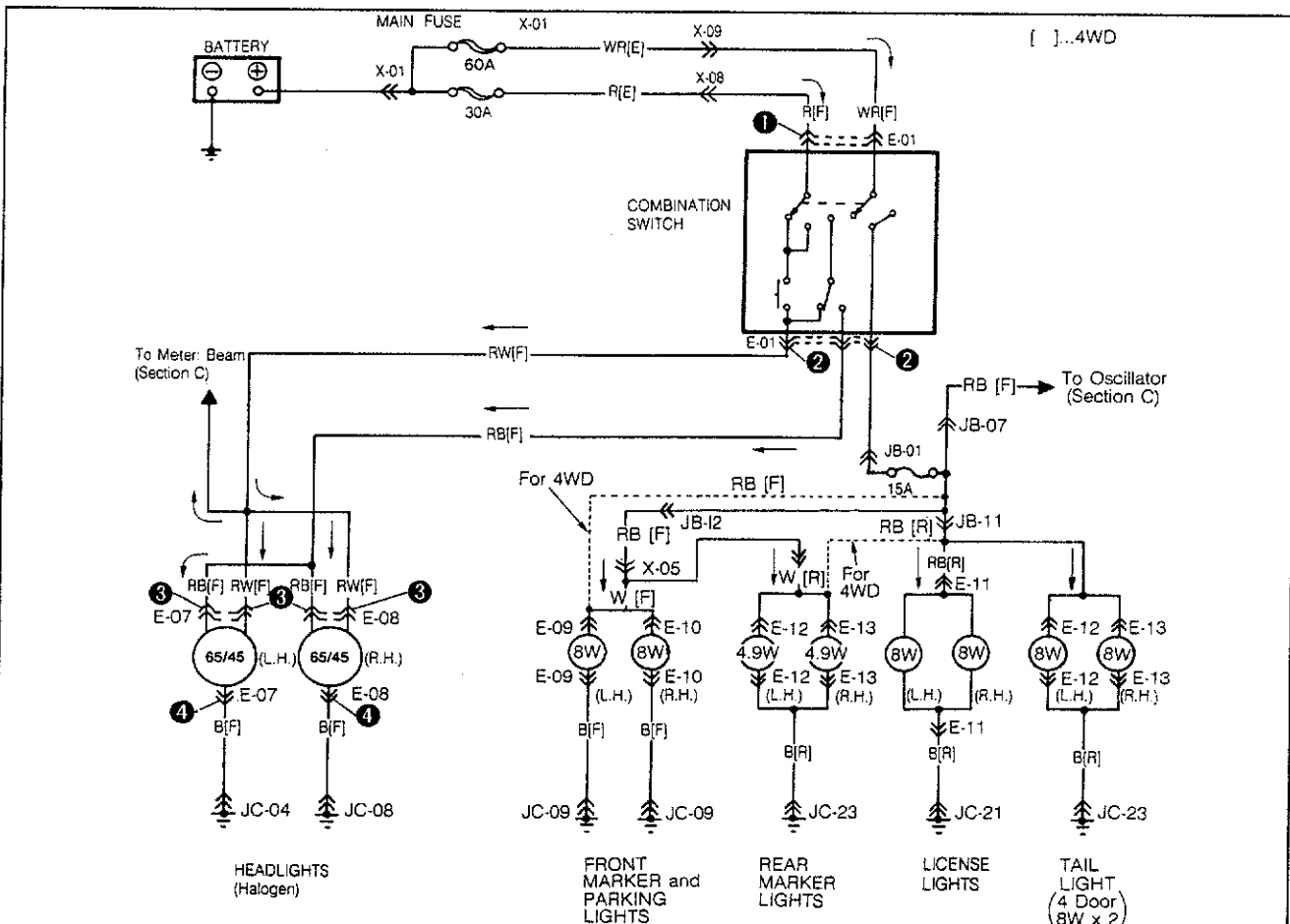



# 15 HEADLIGHT

## TROUBLESHOOTING

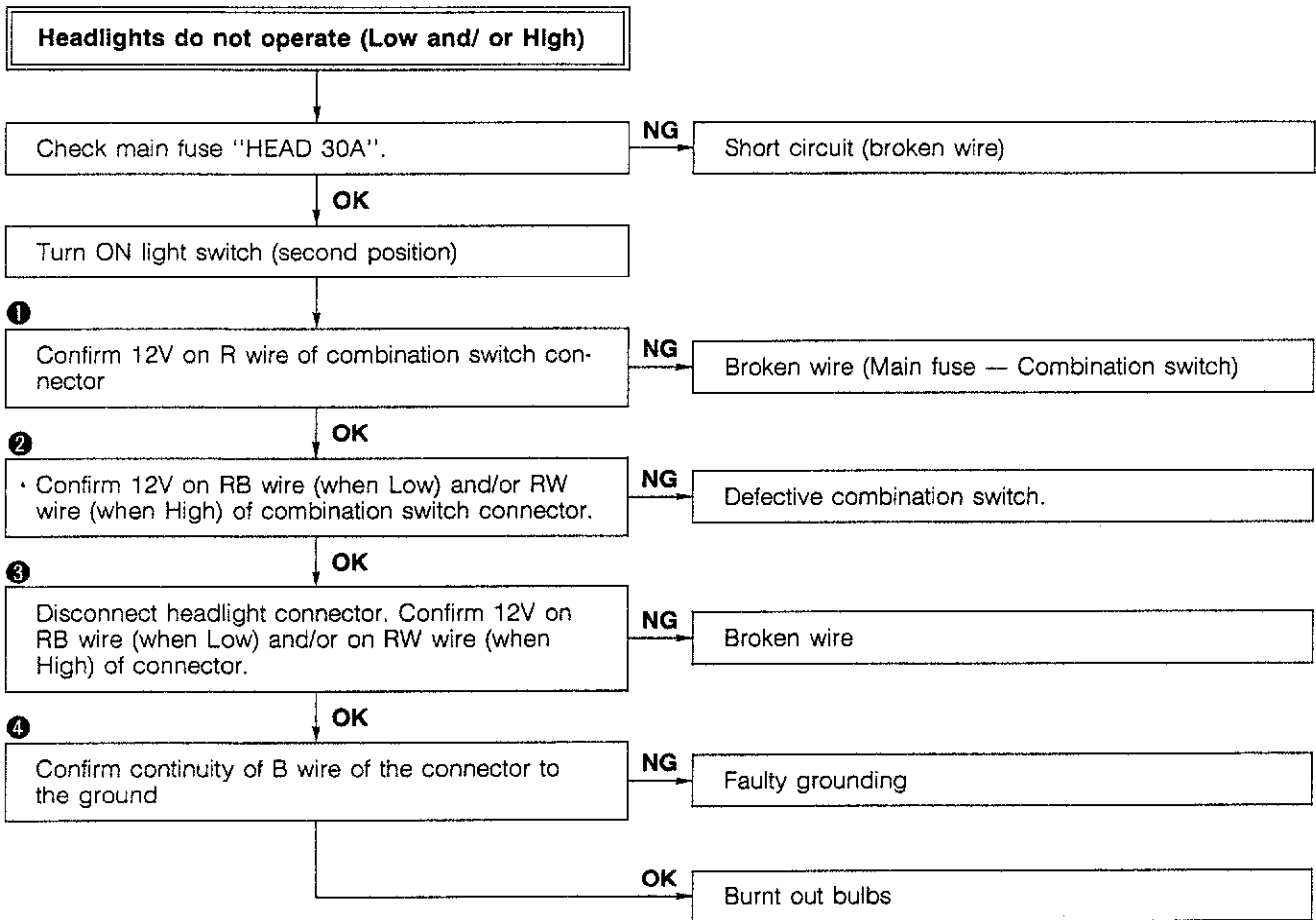

83U15X-066

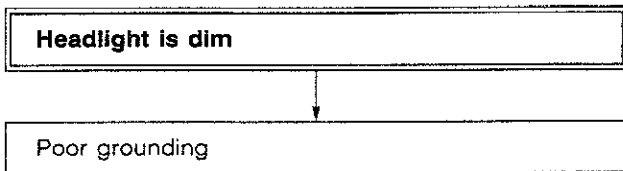

73U15X-049

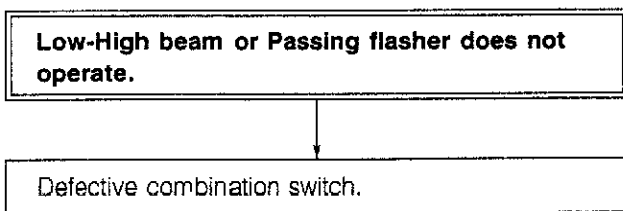

73U15X-050

REAR WINDOW WIPER

STRUCTURAL VIEW

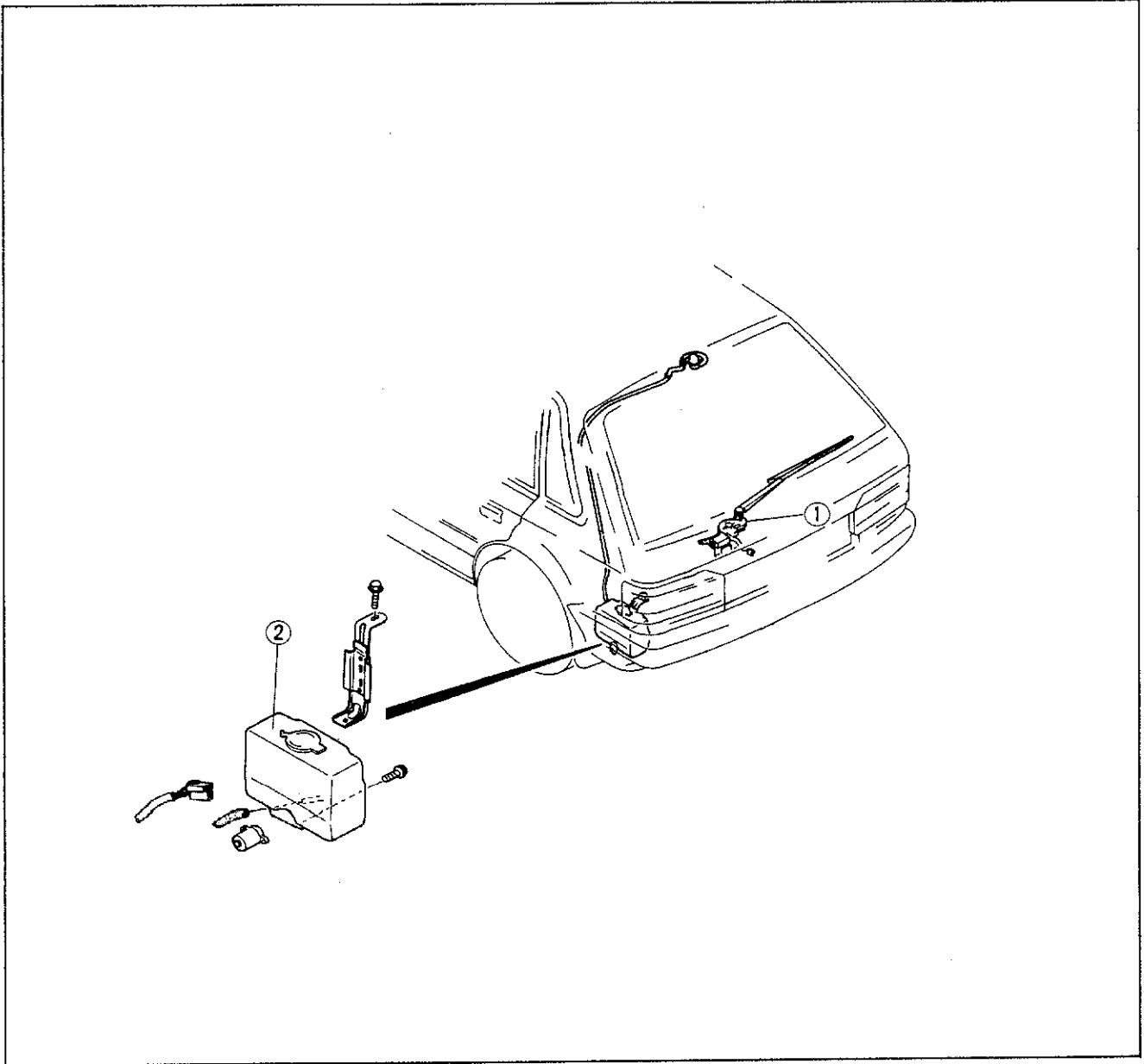

83U15X-067

1. Rear wiper motor

2. Rear washer

# 15 REAR WINDOW WIPER

## CIRCUIT DIAGRAM

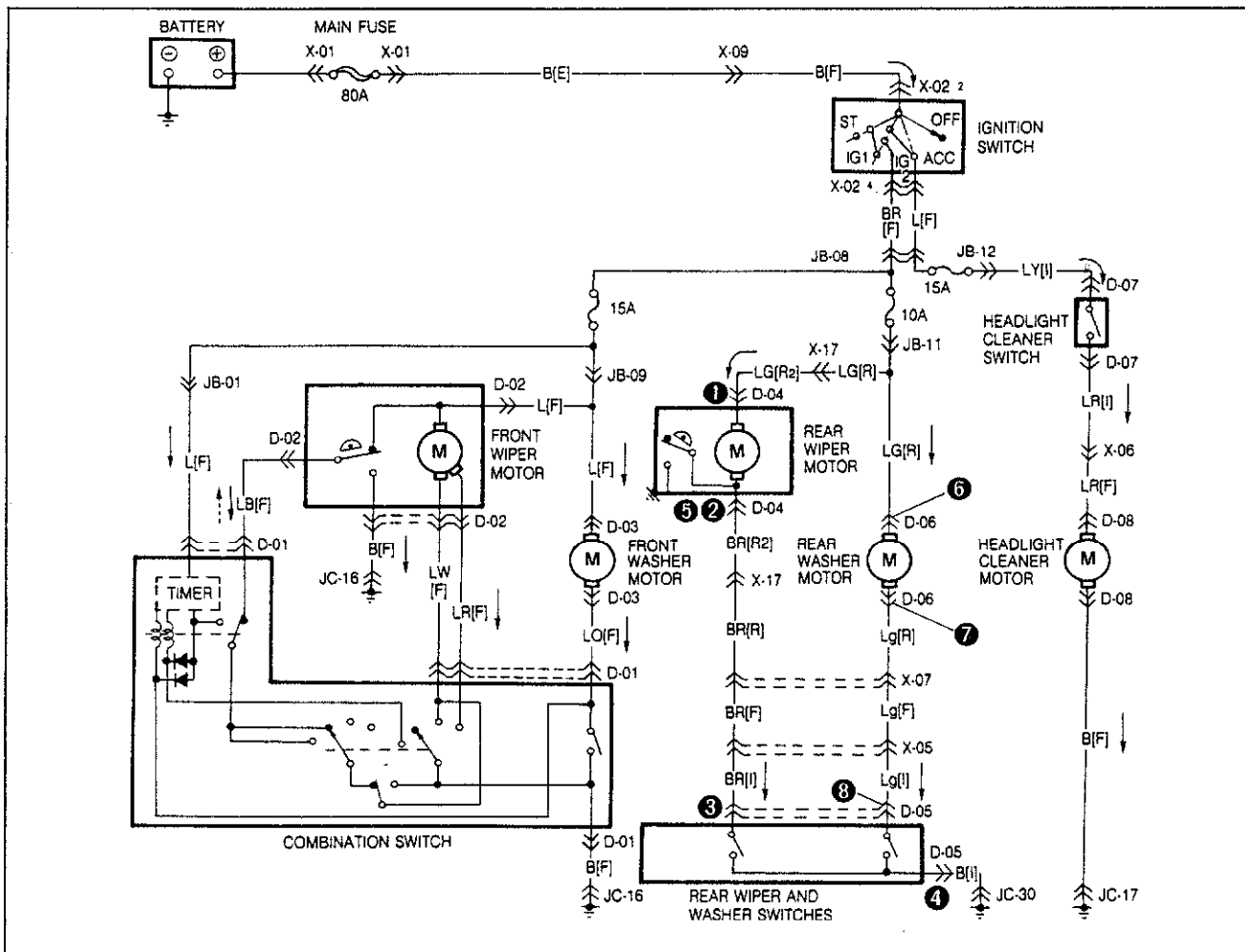

<p>D-01 Combination Switch [F]</p>	<p>D-02 Front Wiper Motor [F]</p>	<p>D-03 Front Washer Motor [F]</p>	<p>D-04 Rear Wiper Motor [R2]</p>
<p>D-05 Rear Wiper And Washer Switches [I]</p>	<p>D-06 Rear Washer Motor [R]</p>	<p>D-07 Headlight Cleaner Switch [I] (E-03)</p>	<p>D-08 Headlight Cleaner Motor [F]</p>

## TROUBLESHOOTING

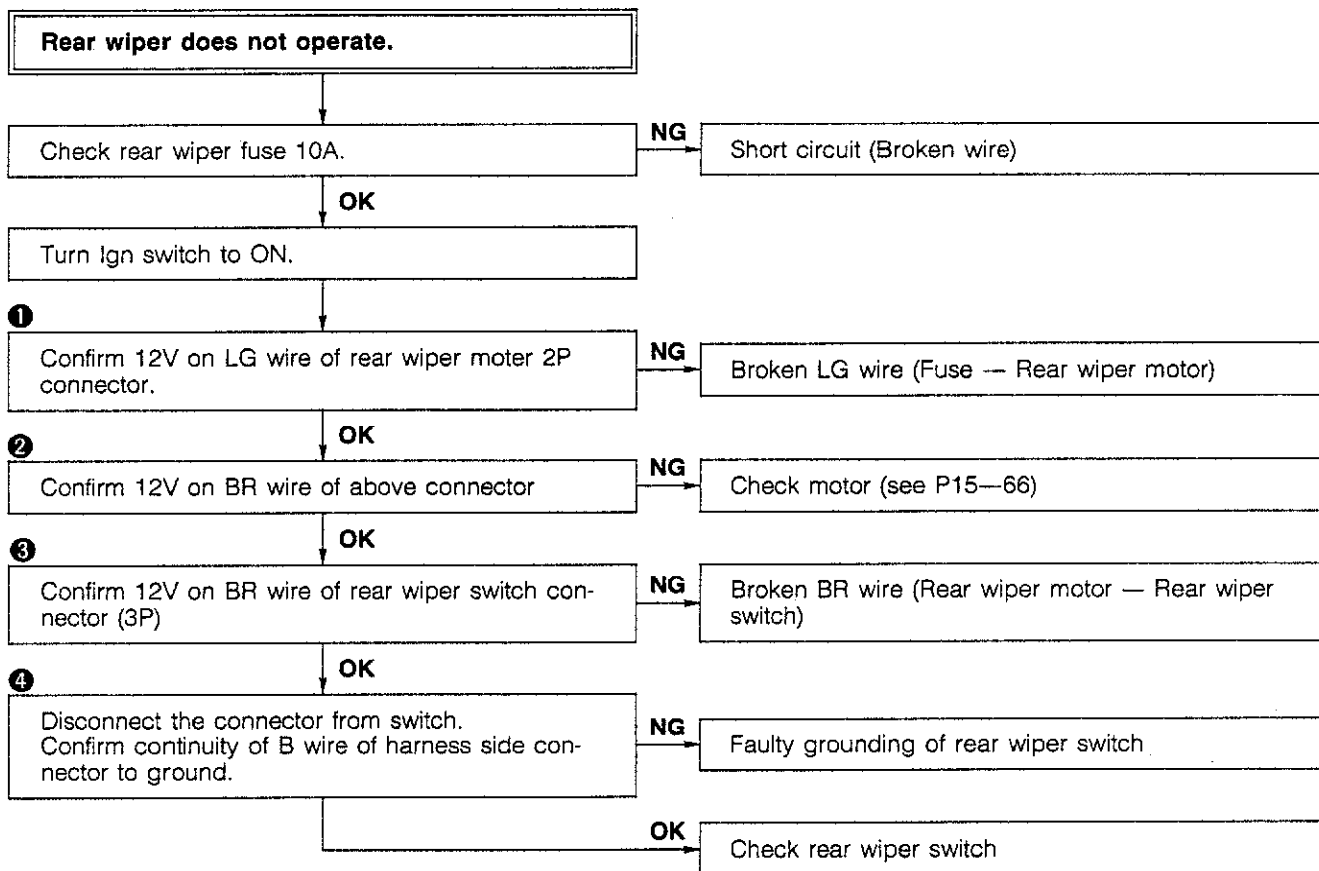

83U15X-069

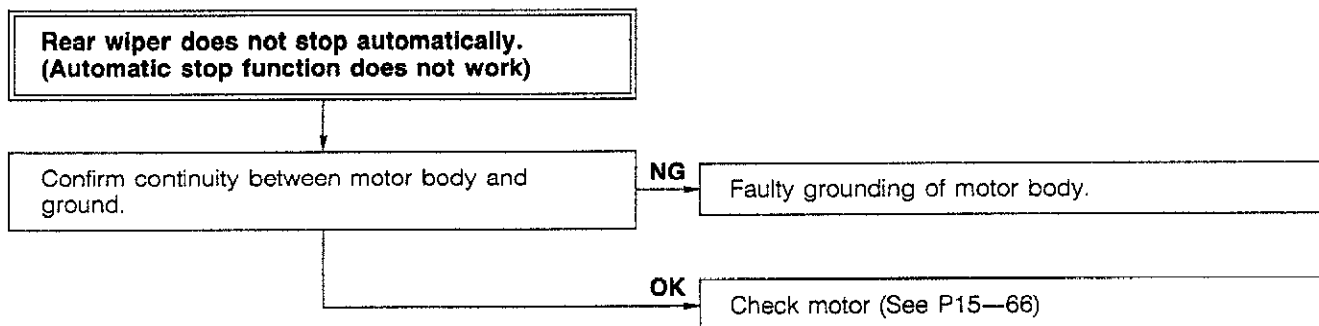

83U15X-070

# 15 REAR WINDOW WIPER

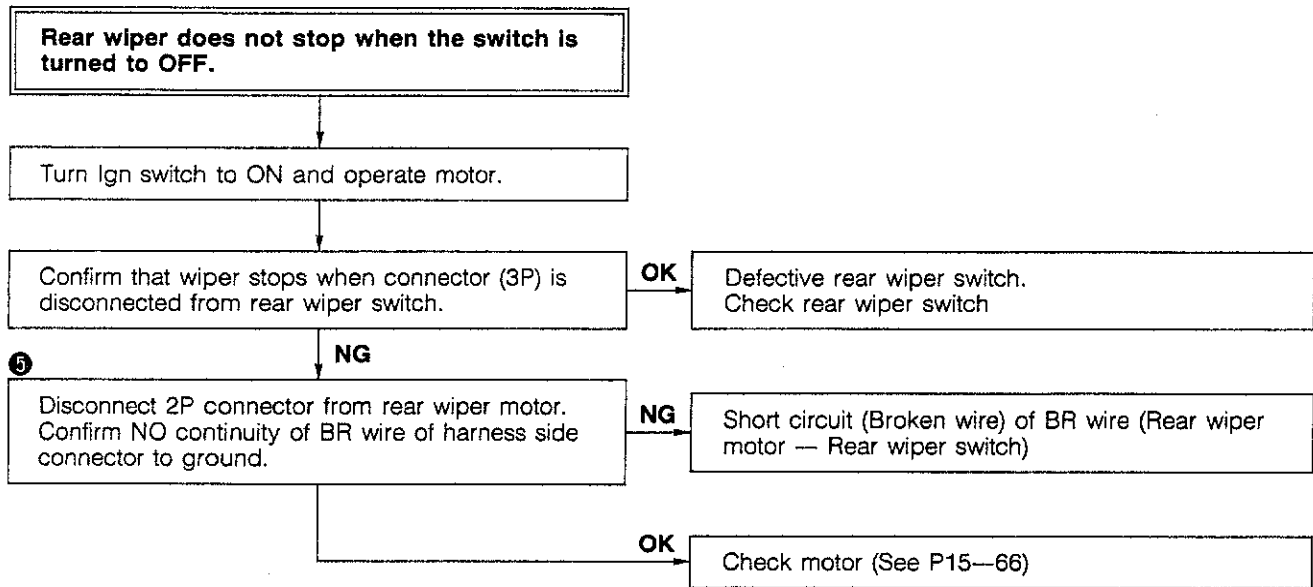

83U15X-071

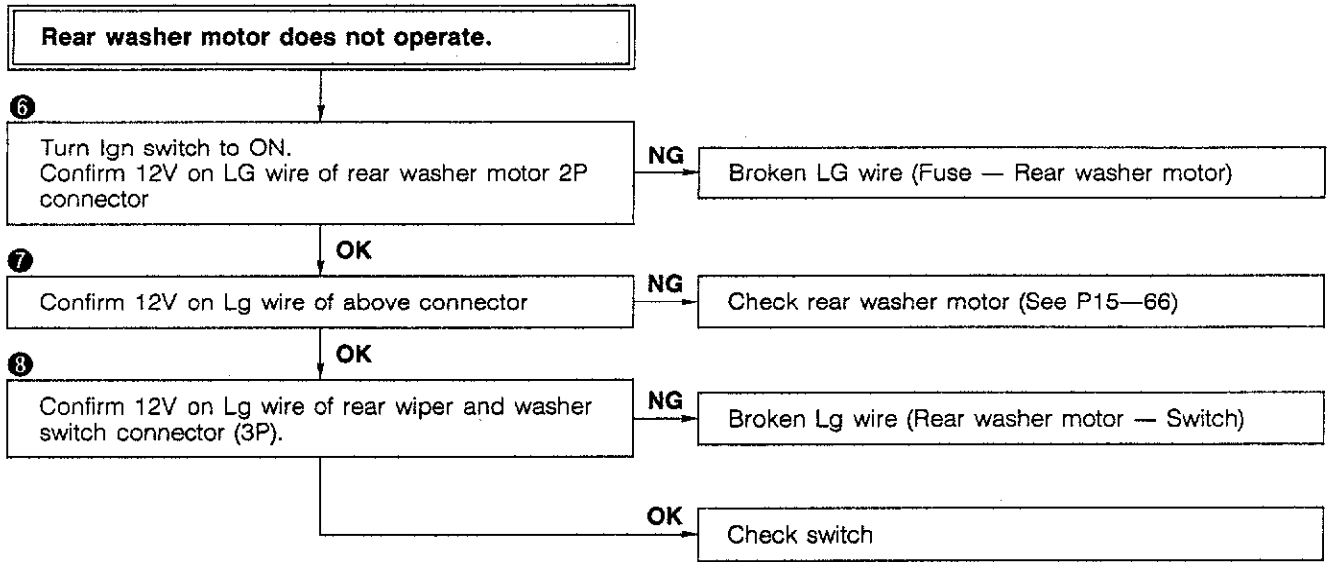

83U15X-072

# 15 REAR WINDOW WIPER

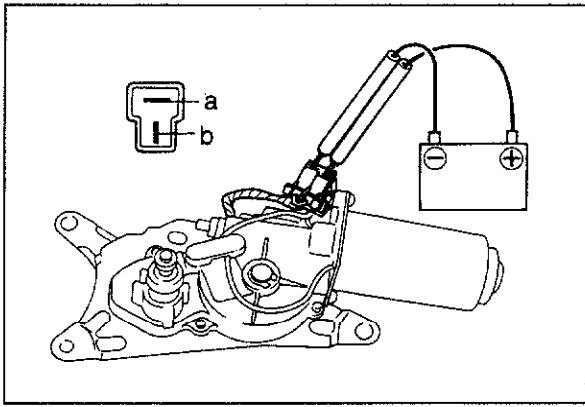

73U15X-054

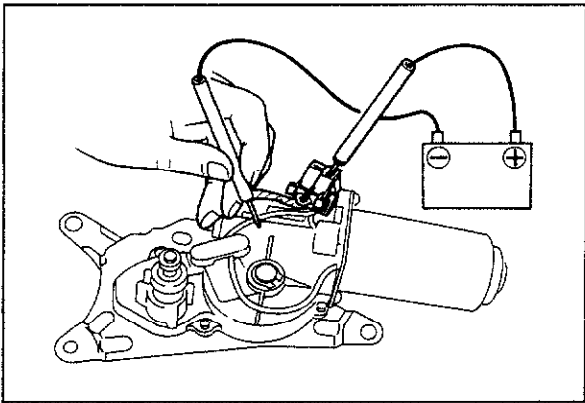

63U15X-113

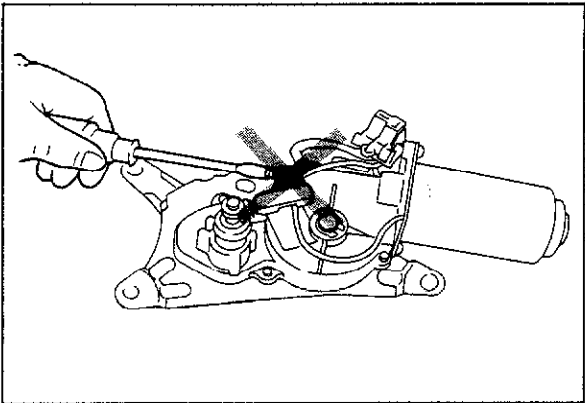

63U15X-114

## OPERATION CHECK OF REAR WIPER MOTOR

1. Confirm that the motor operates continuously when 12V is connected to the "a" terminal and ground is connected to the "b" terminal of the motor.

2. Start the motor again.

Disconnect the ground from the "b" terminal, and then connect the ground to the motor body immediately. Confirm that the motor shaft reaches the auto-stop position, and that there is conductivity through the grounding of the motor body.

### Caution

**Do not turn the worm gear adjusting lock nut.**

WINDSHIELD WIPER

STRUCTURAL VIEW

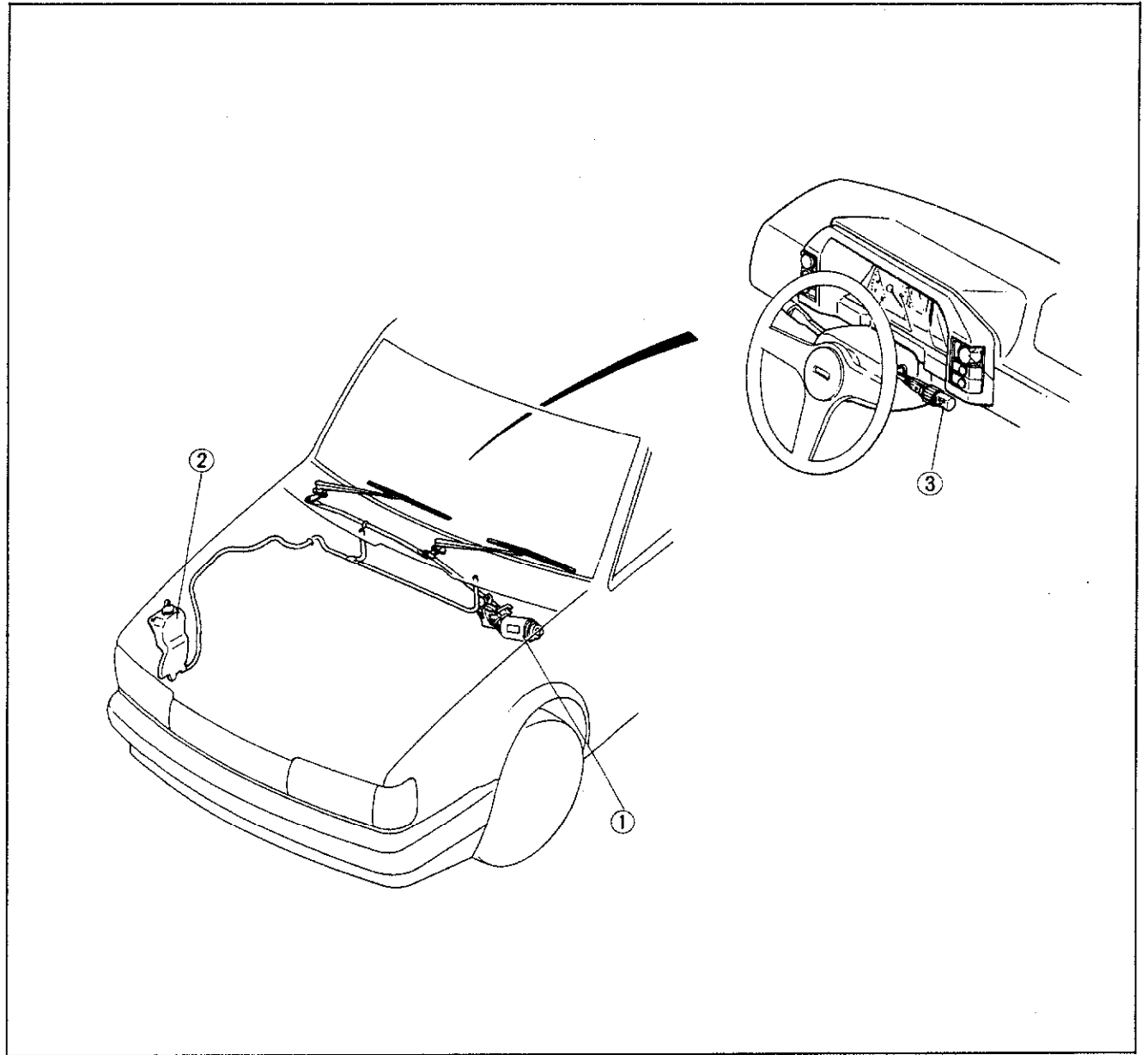

63U15X-115

1. Wiper motor

2. Washer tank

3. Washer switch



# 15 WINDSHIELD WIPER

## CIRCUIT DIAGRAM

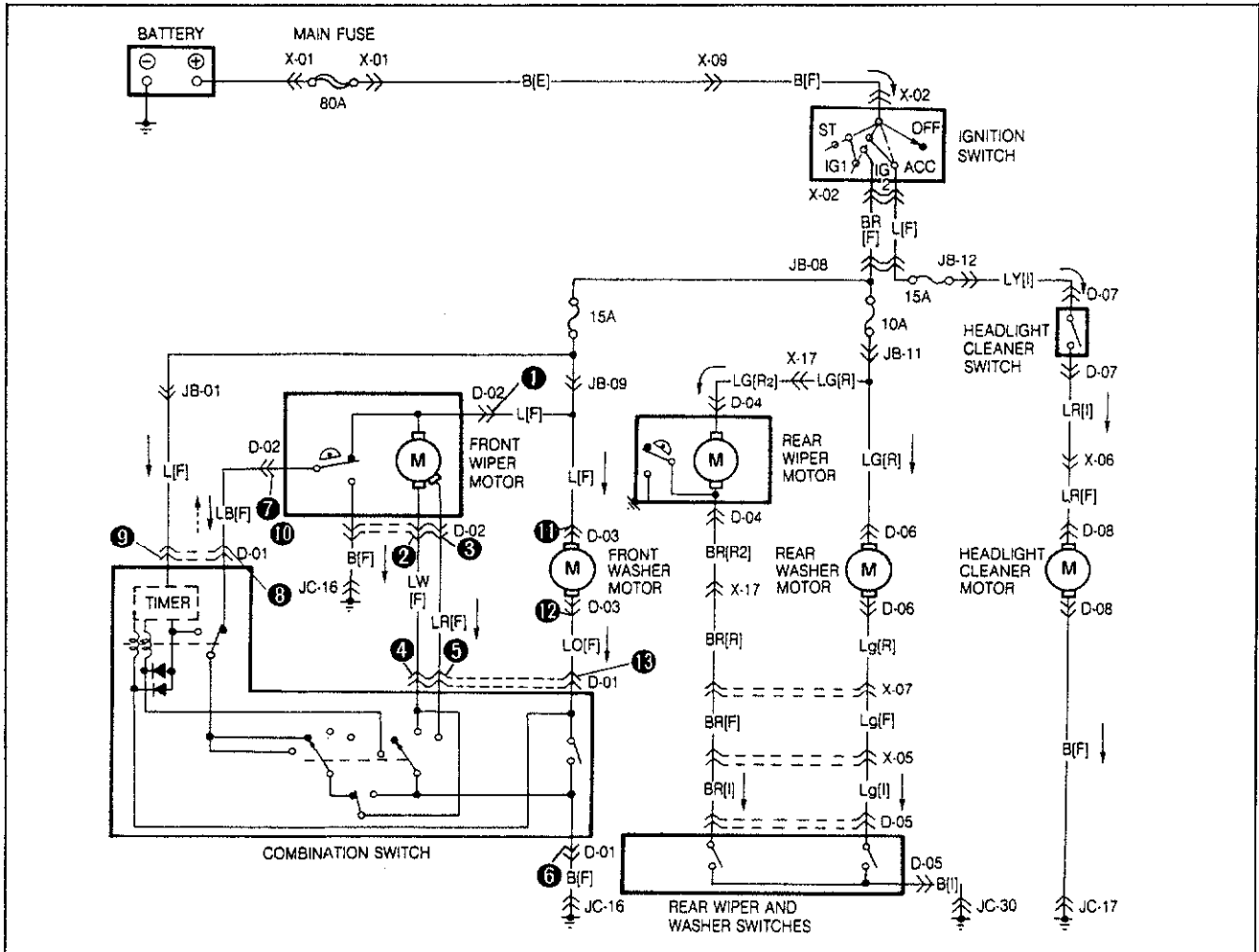

<p>D-01 Combination Switch [F]</p>	<p>D-02 Front Wiper Motor [F]</p>	<p>D-03 Front Washer Motor [F]</p>	<p>D-04 Rear Wiper Motor [R2]</p>
<p>D-05 Rear Wiper And Washer Switches [I]</p>	<p>D-06 Rear Washer Motor [R]</p>	<p>D-07 Headlight Cleaner Switch [I] (E-03)</p>	<p>D-08 Headlight Cleaner Motor [F]</p>

## TROUBLESHOOTING

Wiper does not operate in Lo or Hi position.

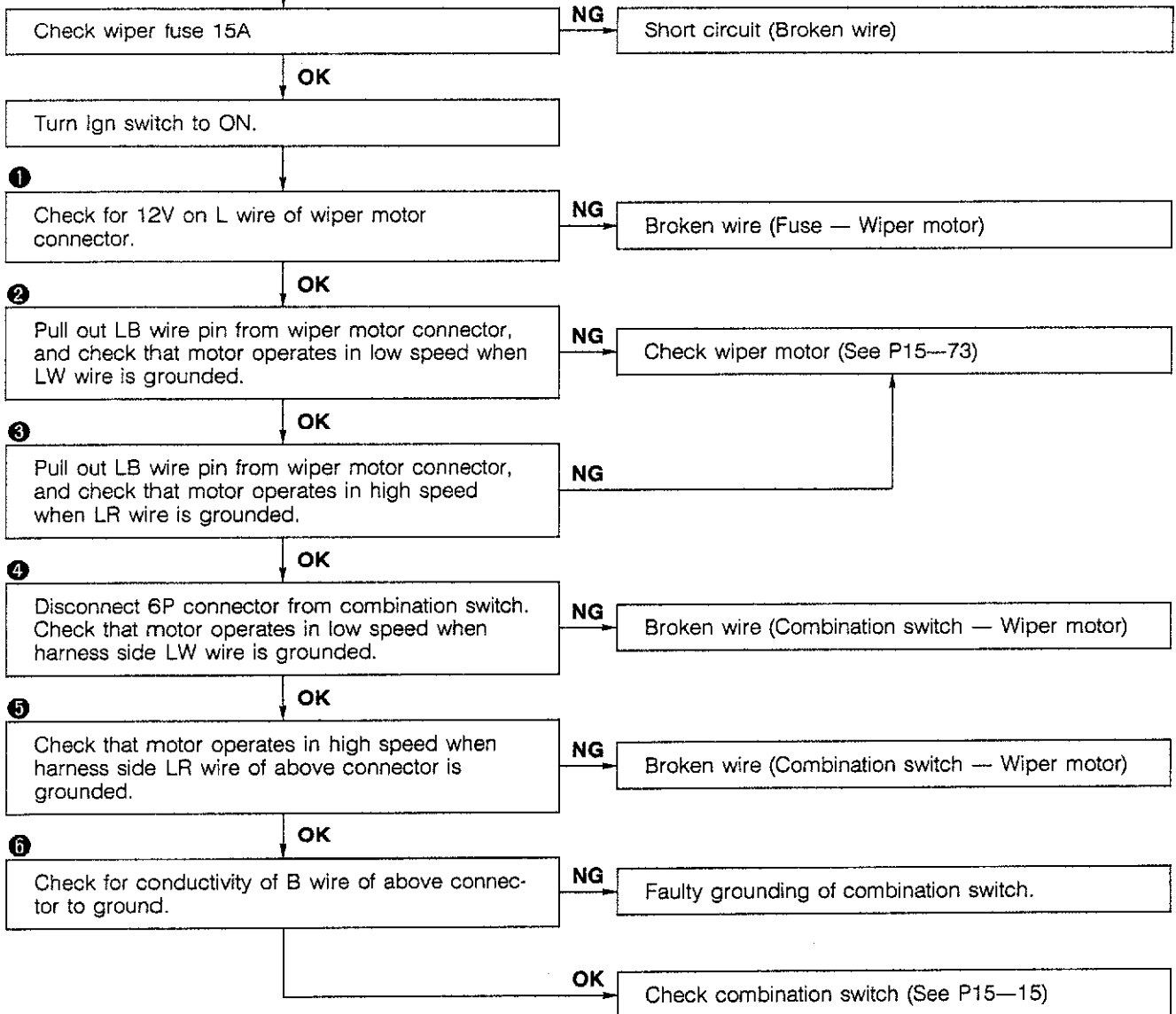
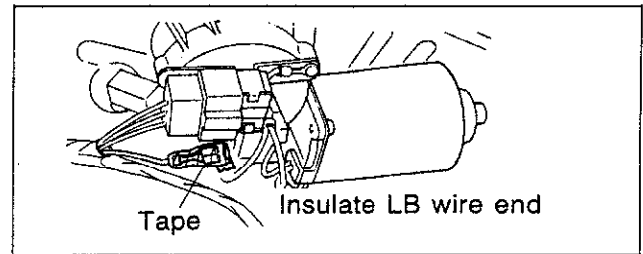

83U15X-074

# 15 WINDSHIELD WIPER

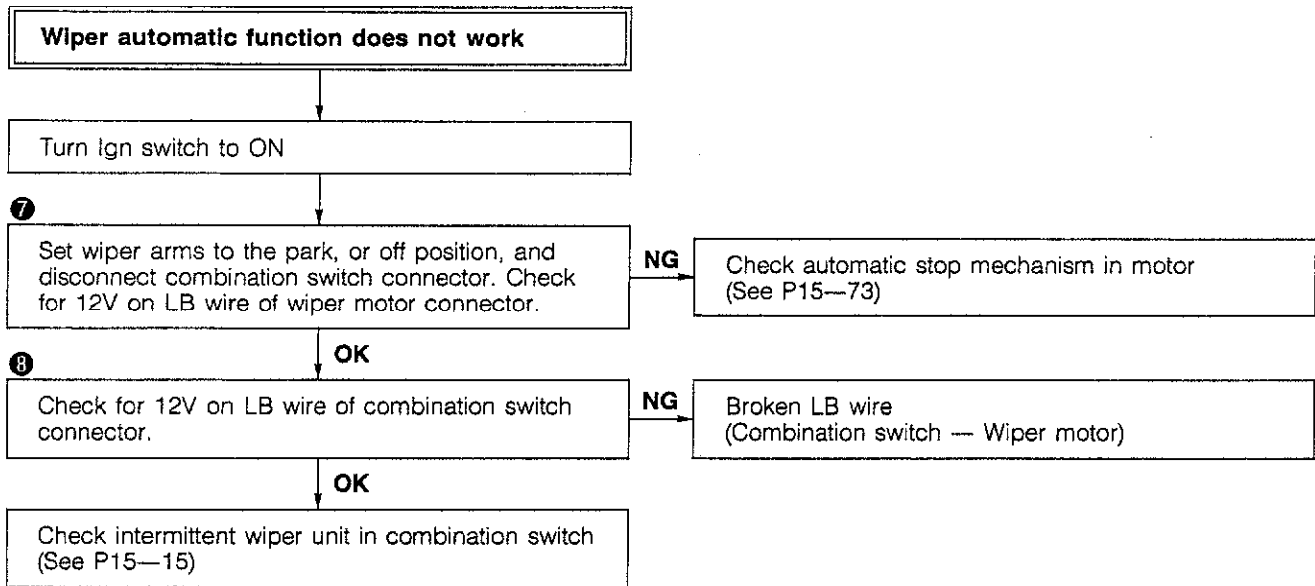

83U15X-075

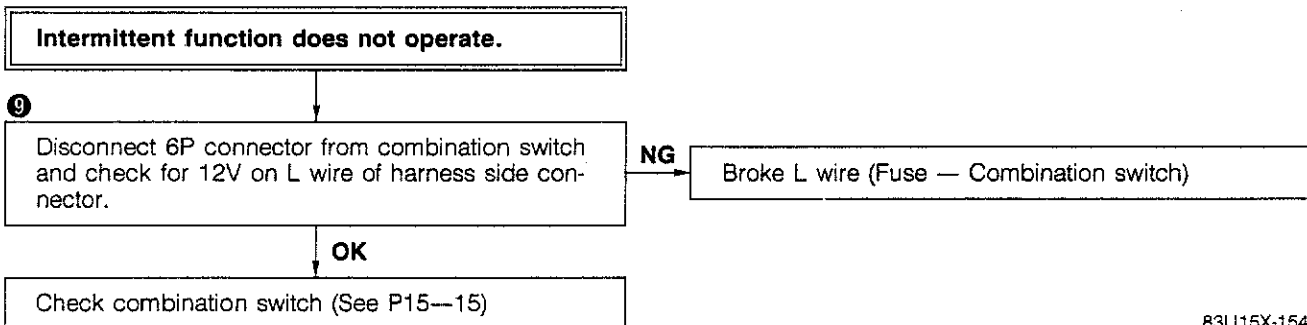

83U15X-154

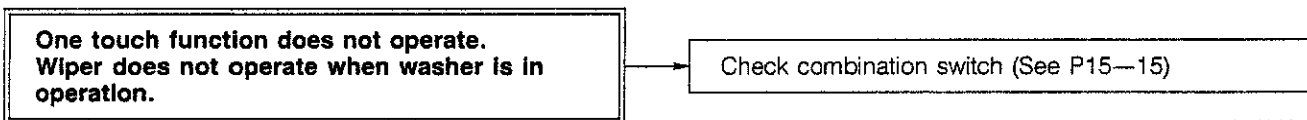

83U15X-076

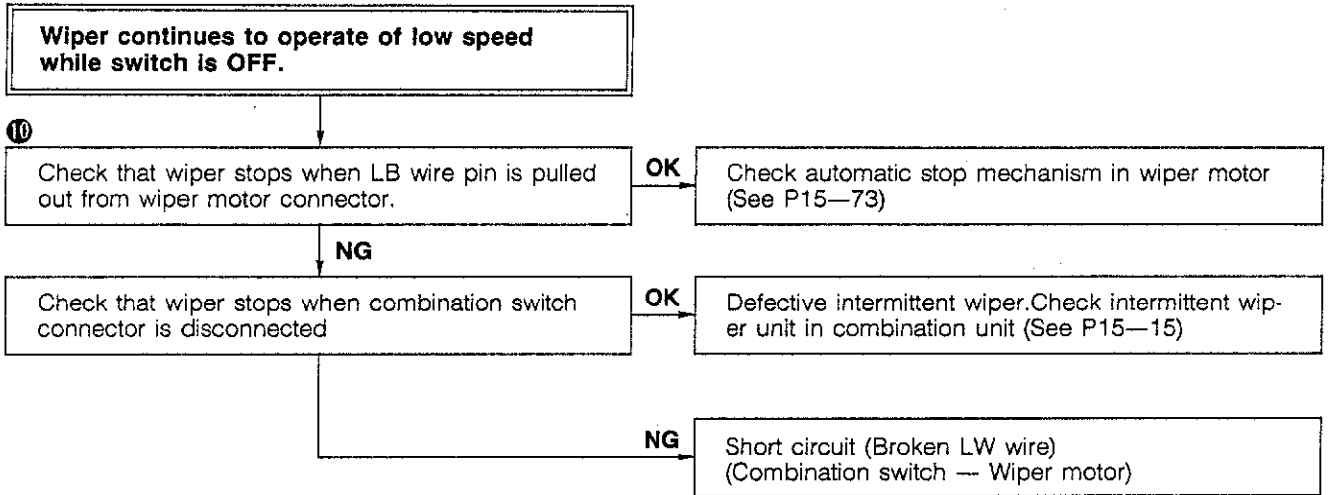

83U15X-077

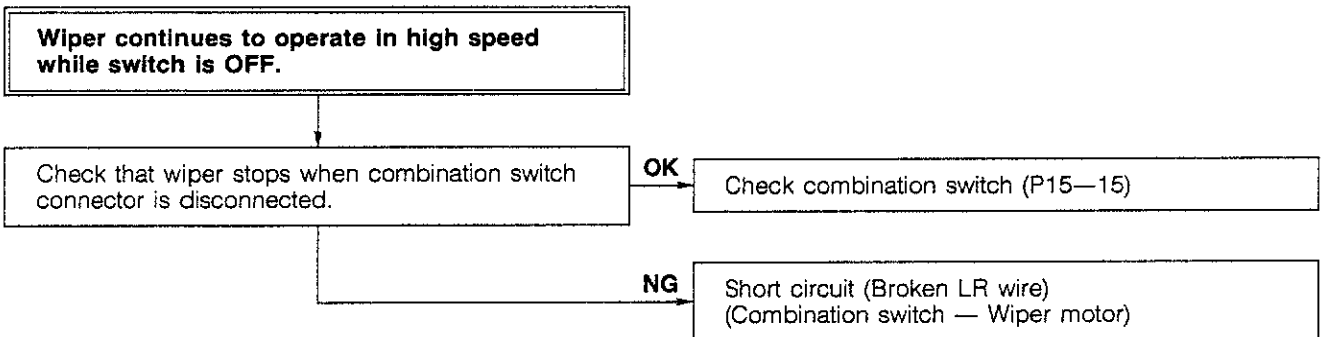

83U15X-078

# 15 WINDSHIELD WIPER

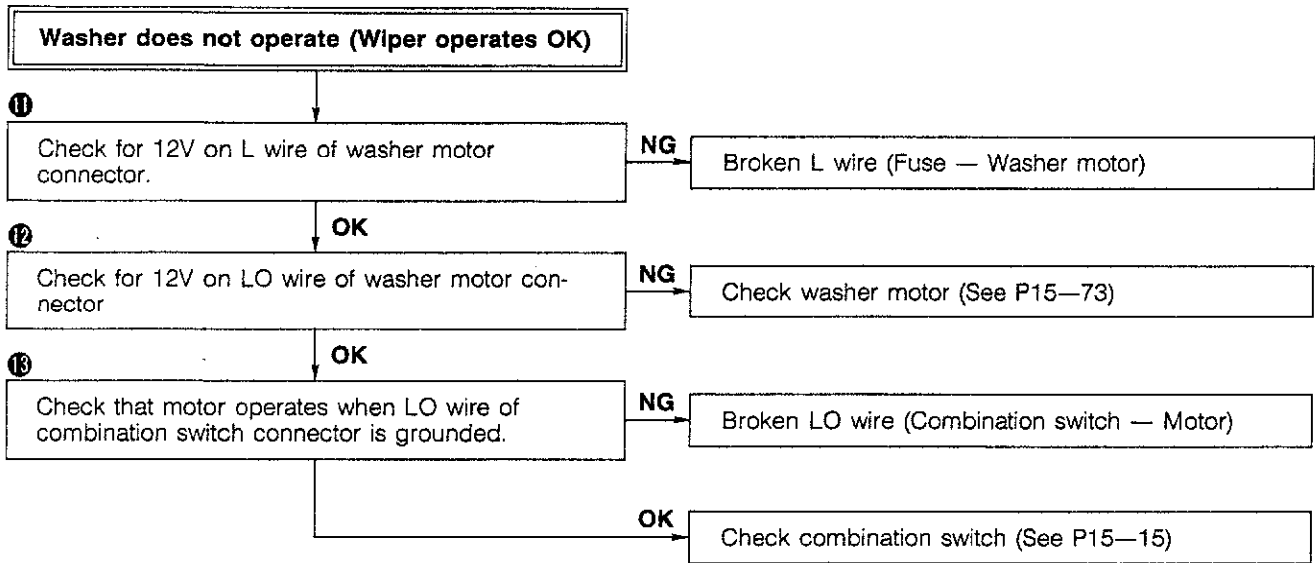

83U15X-079

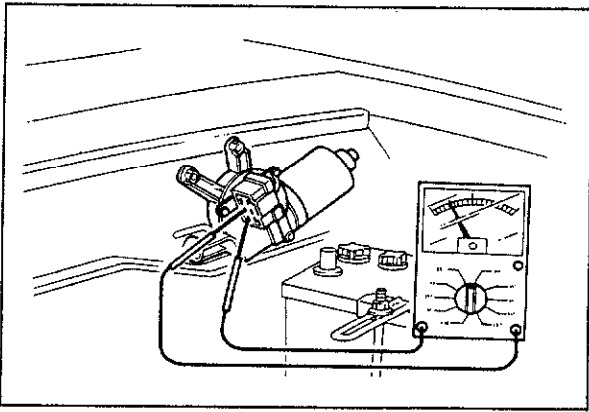

63U15X-125

### WIPER MOTOR Conductivity Check

1. Check for conductivity between the terminals.

Terminals	Conductivity	Note
b-a	Conductive	—
b-c	Conductive	—
b-d	Conductive	Normal resting position
e-d	Conductive	Except for normal resting position

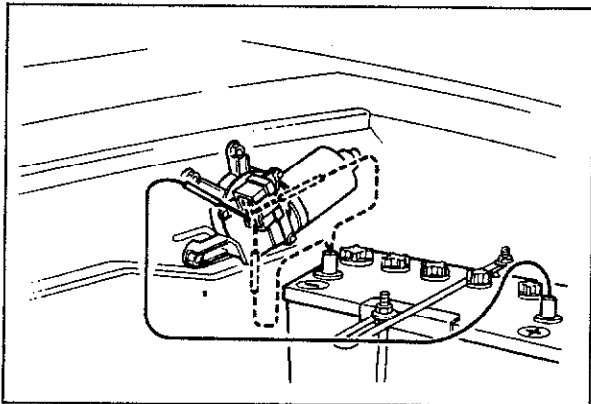

83U15X-080

### Operation check

1. Check the operation by applying an electrical source to the motor.

Terminal		Operation speed
12V	Ground	
b	a	Low
	c	High

2. Check for conductivity between the "b" and "d" terminals and between the "d" and "e" terminals while operating the motor in low speed.

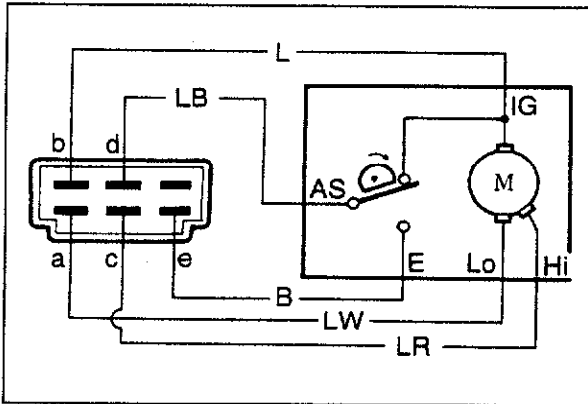

Terminals	Conductivity
b-d	Non-conductive most of the time, and becomes conductive once per turn
d-e	Conductive most of the time, and becomes non-conductive once per turn

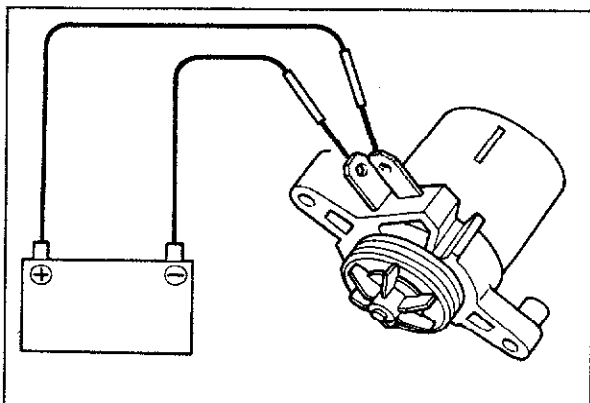

83U15X-081

### WASHER MOTOR Conductivity Check

Check for conductivity between the "a" and "b" terminals.

### Operation check

Connect the 12V to the "a" terminal and the ground to the "b" terminal, and check that the motor operates.

# 15 POWER DOOR LOCK

## POWER DOOR LOCK

### STRUCTURAL VIEW

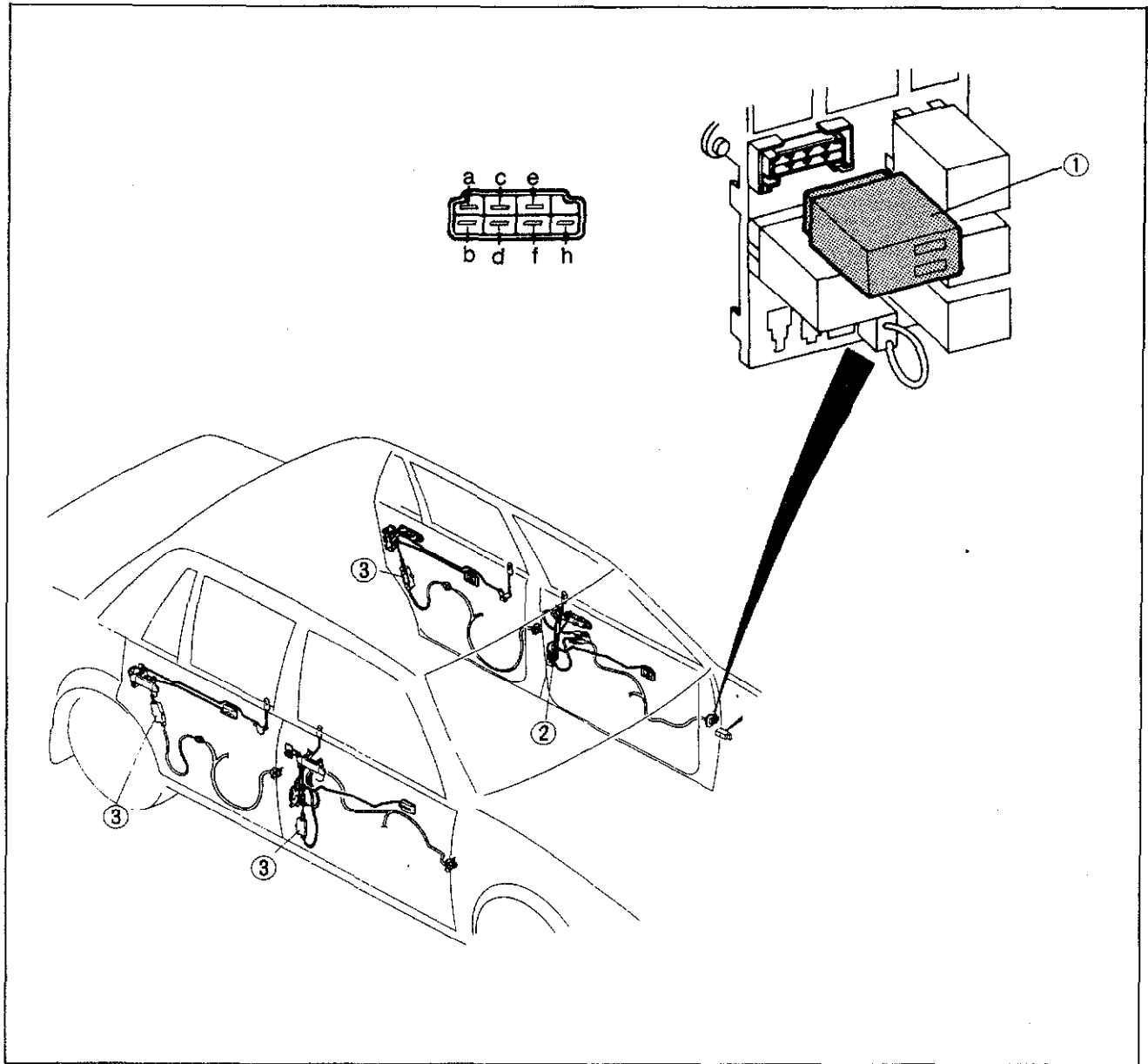

73U15X-063





1. Door lock relay

2. Door lock switch

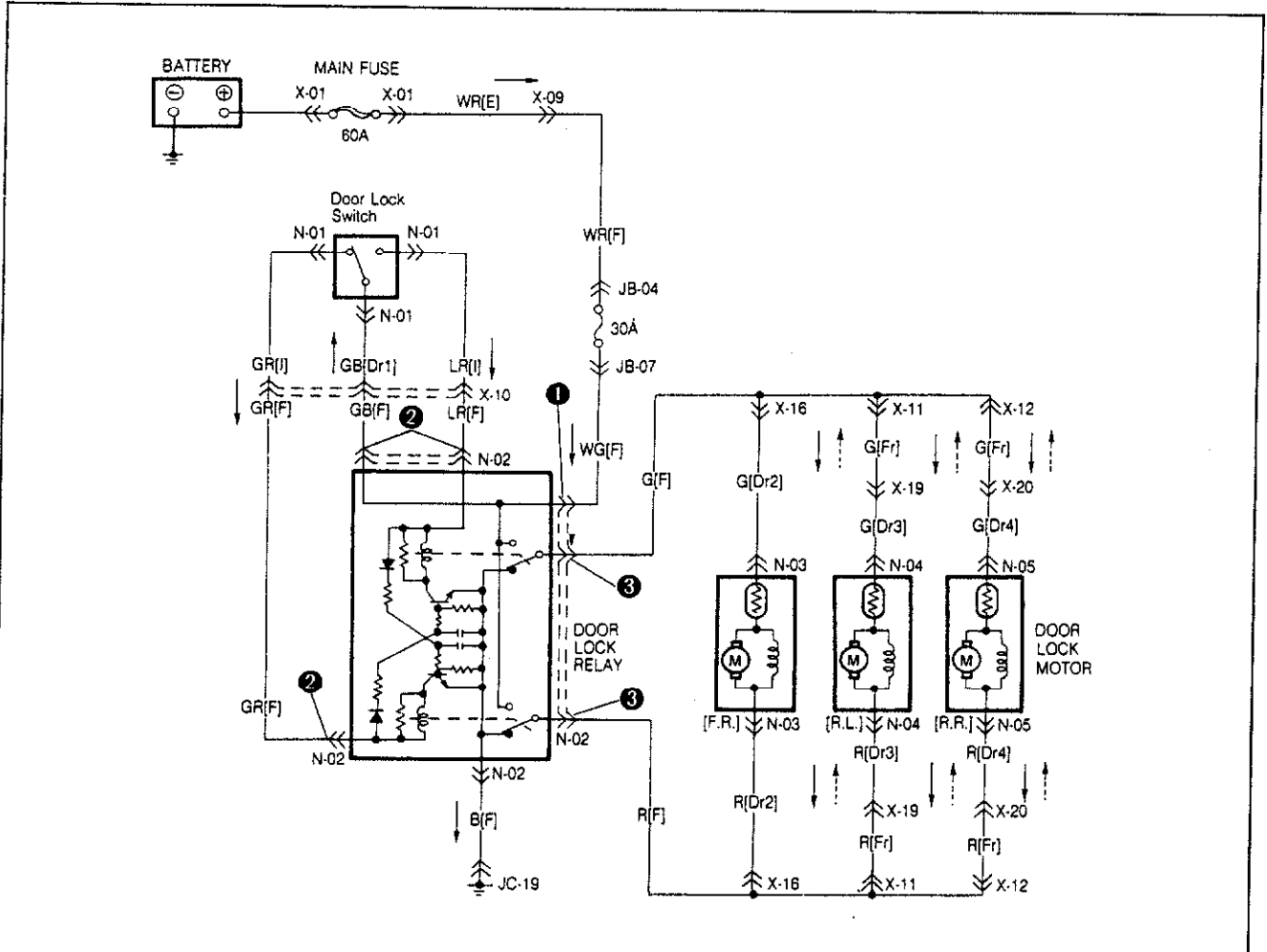
3. Door lock actuator

## CIRCUIT DIAGRAM



<p>N-01 Power Door Lock Switch [Dr1]</p> 	<p>N-02 Power Door Lock Relay [F]</p> 	<p>N-03 Power Door Lock Motor F.R. [Dr2]</p> 	<p>N-04 Power Door Lock Motor R.L. [Dr3]</p> 
<p>N-05 Power Door Lock Motor R.R. [Dr4]</p> 			



# 15 POWER DOOR LOCKS

## TROUBLESHOOTING

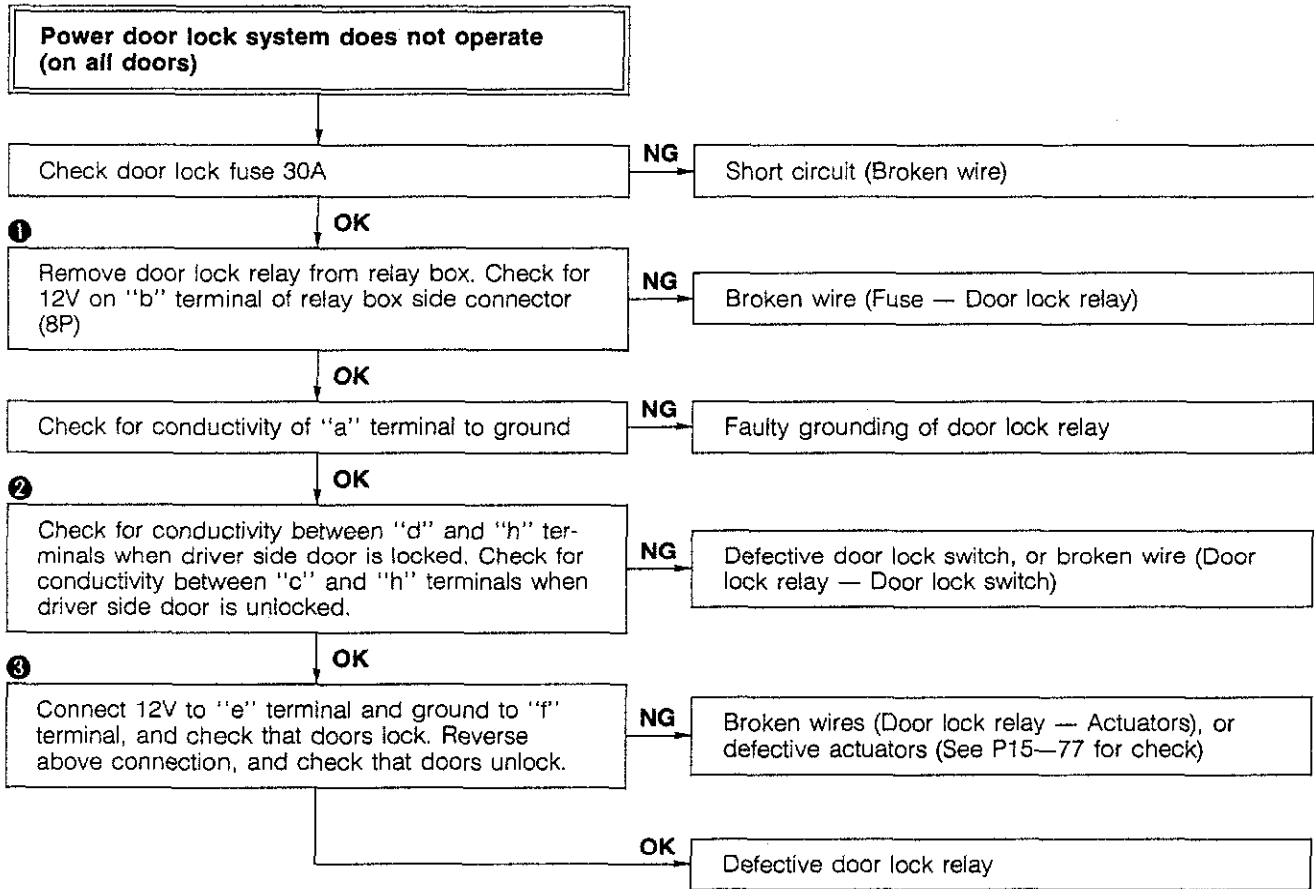

83U15X-083

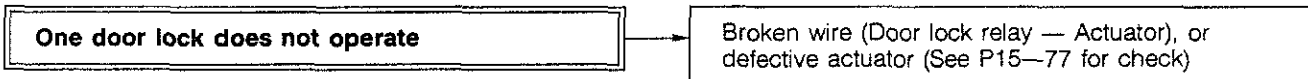

83U15X-084

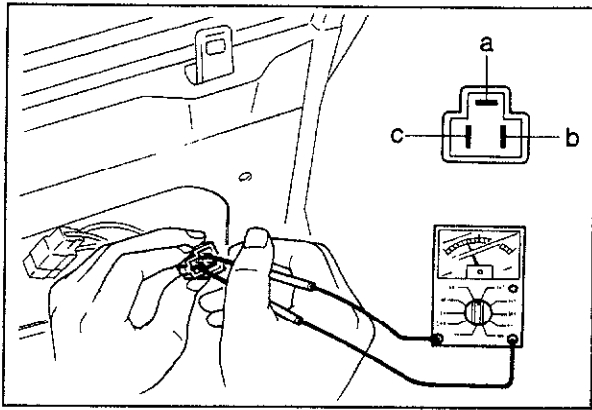

83U15X-085

## INSPECTION Door Lock Switch

Check for conductivity between the terminals.

	a	b	c
Locked	○—○	○—○	
Unlocked	○—○		○—○

○—○ : Indicates conductive

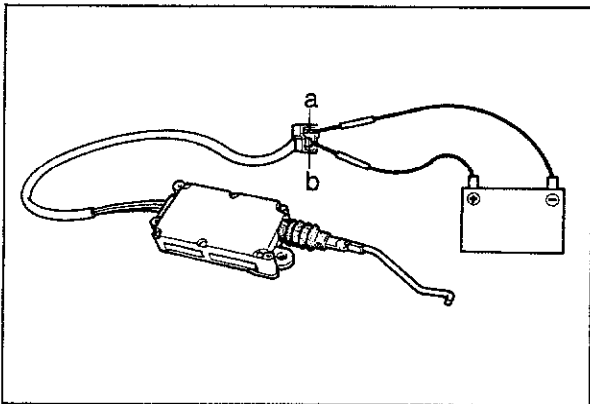

83U15X-086

## Actuator

1. Connect the 12V to the "b" terminal and the ground to the "a" terminal, and check that the actuator locks.
2. Reverse the above connections, and check that the actuator unlocks.

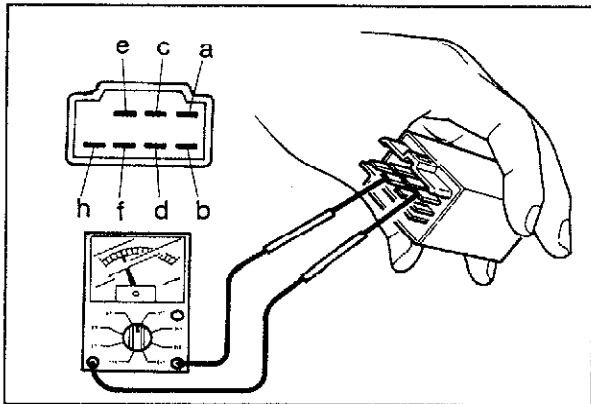

83U15X-087

## Door Lock Timer Unit

1. Check the conductivity between the terminals.

Terminals	Conductivity	Terminals	Conductivity	Terminals	Conductivity
a—b	X	b—d	X	c—h	X
a—c	○	b—e	X	d—e	○
a—d	○	b—f	X	d—f	○
a—e	○	b—h	○	d—h	X
a—f	○	c—d	○	e—f	○
a—h	X	c—e	○	e—h	○
b—c	X	c—f	○	f—h	X

○...Conductive, X...Non-conductive

## Note

a) Set the tester to x1000Ω range.

b) Conductive includes the state with resistance, and Non-conductive means insulated.

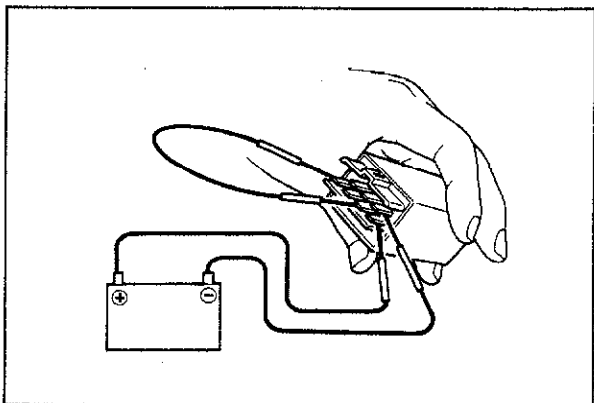

73U15X-067

2. Connect the 12V to the "b" terminal and the ground to the "a" terminal. Then, short circuit the "h" and "d" terminals between the "h" and "c" terminals, and check that the relay clicks.

## POWER WINDOW

### STRUCTURAL VIEW

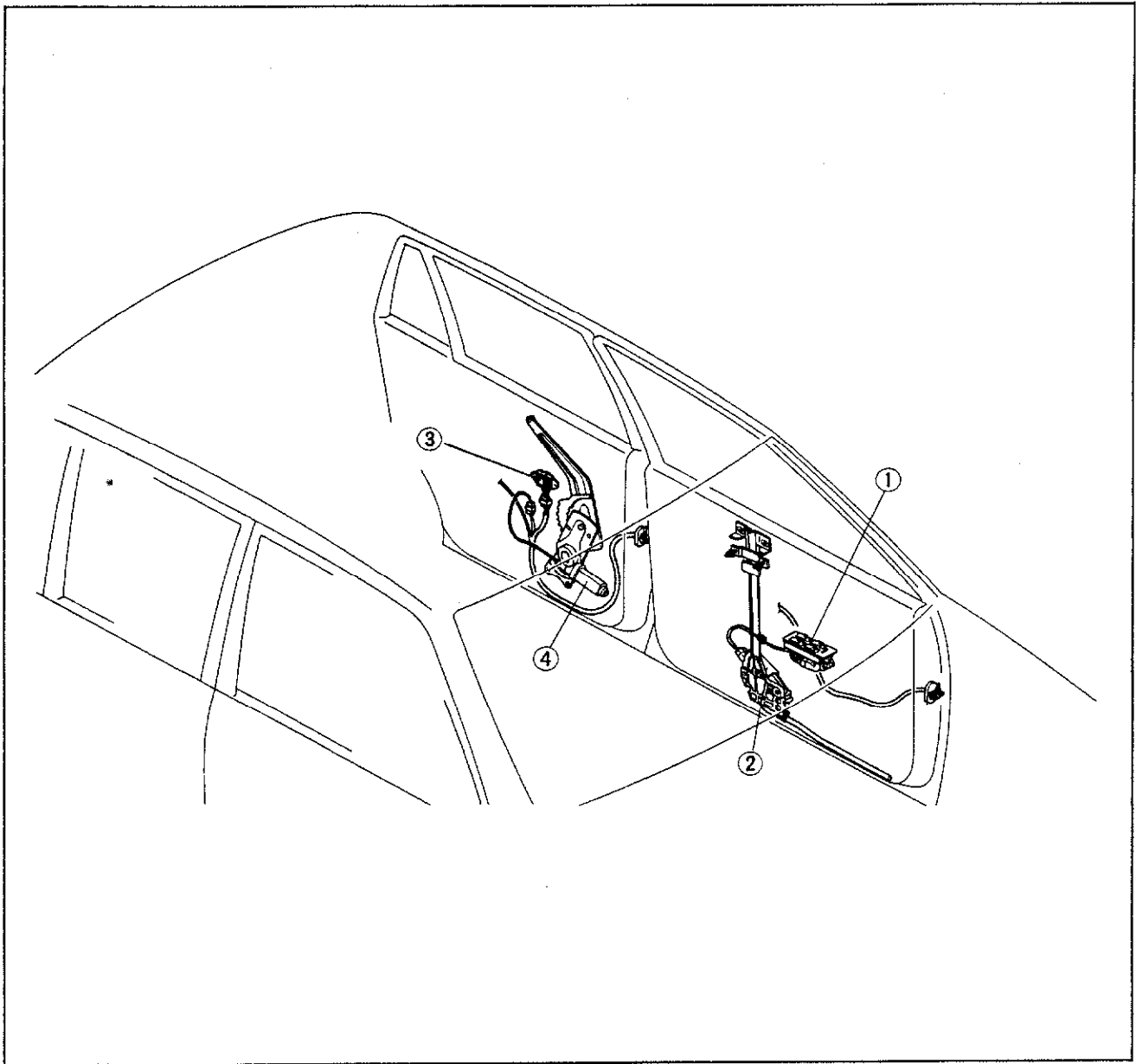

63U15X-136

1. Power window main switch (Driver side)  
2. Front power window motor

3. Power window switch (Rear)  
4. Rear power window motor

CIRCUIT DIAGRAM

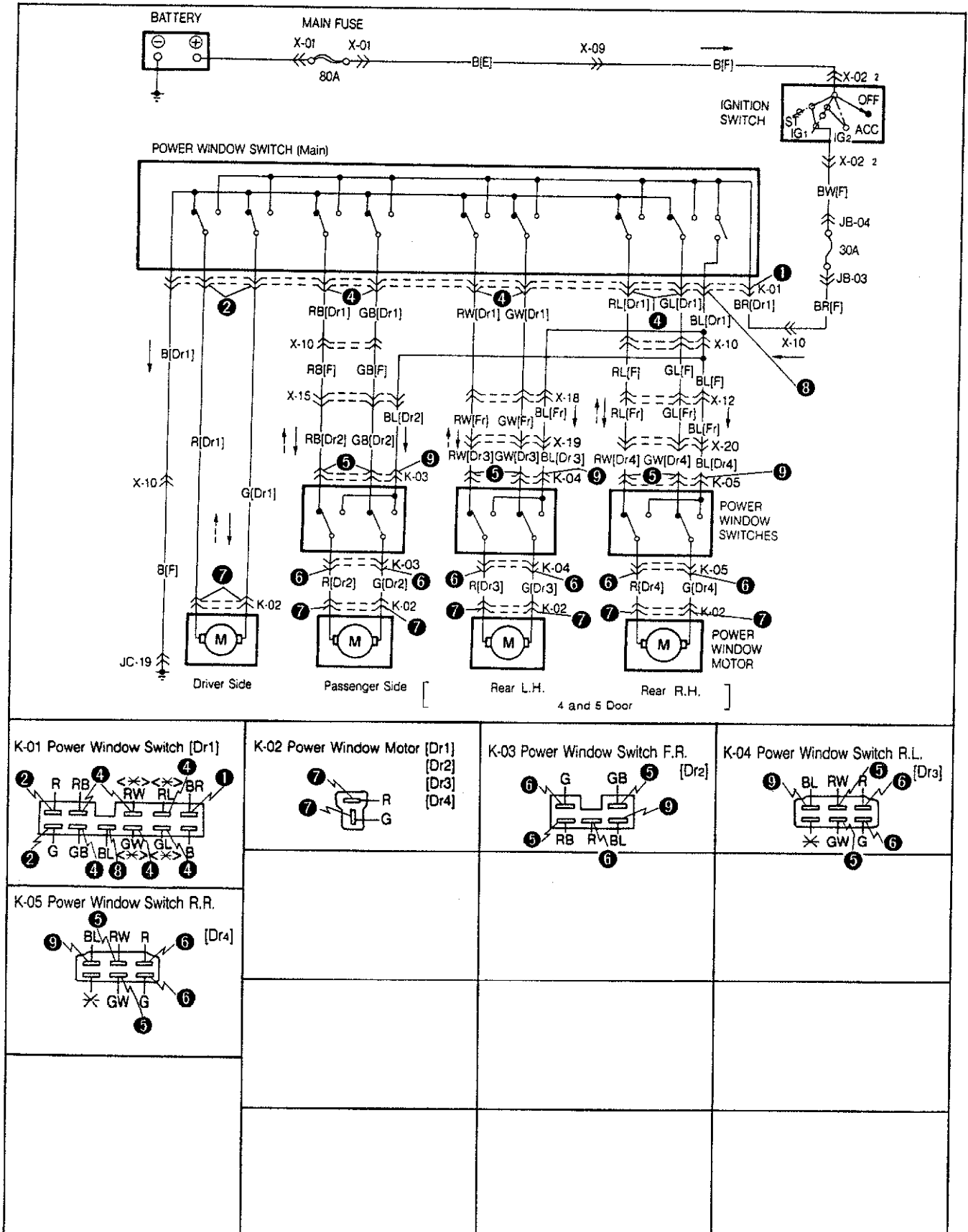

83U15X-088

# 15 POWER WINDOW

## TROUBLESHOOTING

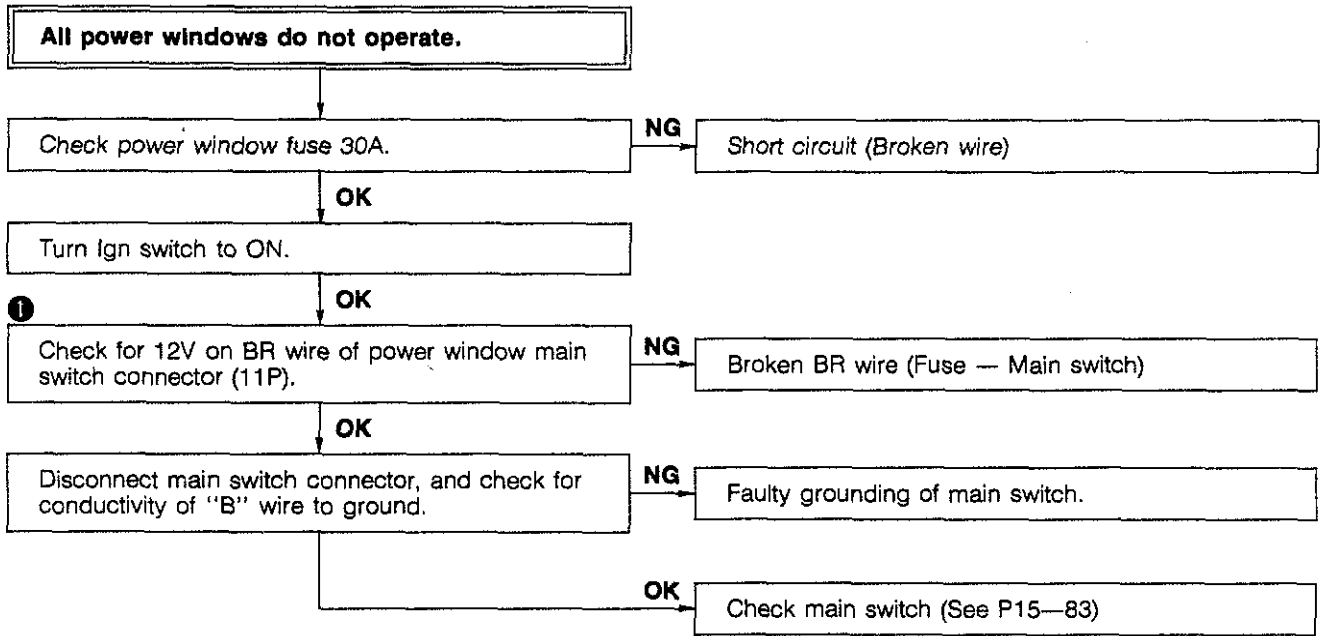

83U15X-089

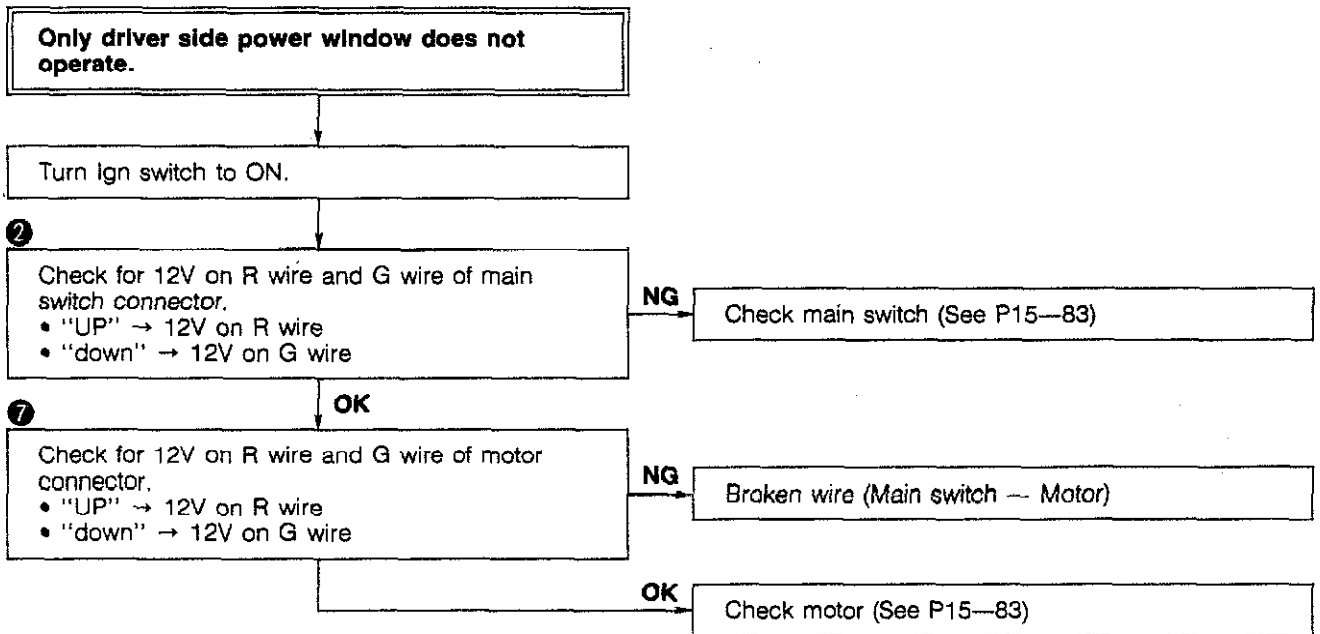

83U15X-090

**Power windows (except for driver side) cannot be operated by main switch.**

Turn Ign switch to ON

**Note**  
Use only the main switch during the checking operation.

**4**

Check for 12V on wires of main switch connector while operating the main switch (driver side)

Door switch	Operation	Wire to check
Passenger side	up	12V on RB
	down	12V on GB
Rear left side	up	12V on RW
	down	12V on GW
Rear right side	up	12V on RL
	down	12V on GL

**NG** → Check main switch (See P15--83)

**OK**

**5**

Check for 12V on wires to each door switch connector (6P or 5P) while operating the main switch (driver side)

Door switch	Operation	Wire to check
Passenger side switch	up	12V on RB
	down	12V on GB
Rear switch	up	12V on RW
	down	12V on GW

**NG** → Broken wire (Main switch — Switch on each door)

**OK**

**6**

Check for 12V on R wire and G wire of each door switch connector (6P or 5P) while operating the main switch (driver side)

- "up" → 12V on R wire
- "down" → 12V on G wire

**NG** → Check the switch on each door. (See P15--83)

**OK**

**7**

Check for 12V on R wire and G wire of each motor connector (2P) while operating the main switch (driver side)

- "up" → 12V on R wire
- "down" → 12V on G wire

**NG** → Broken wire (Switch on each door — Motor)

**OK** → Check motor (See P15--83)

# 15 POWER WINDOW

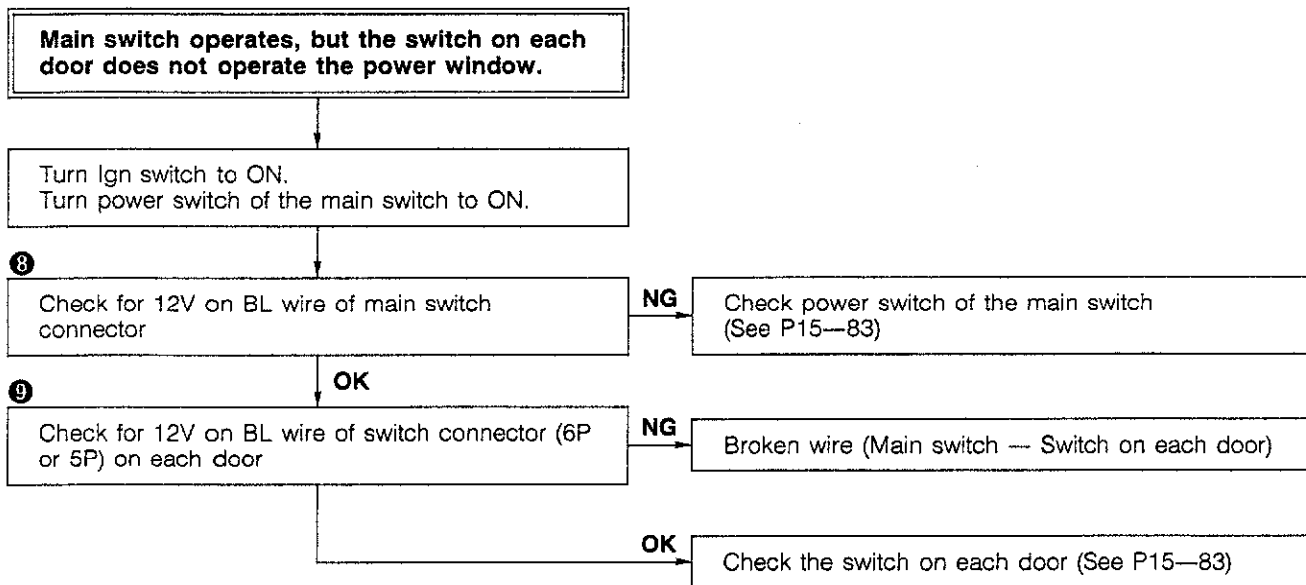

83U15X-092

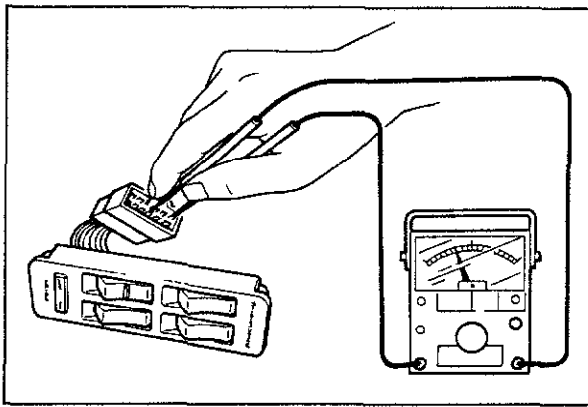

83U15X-093

## INSPECTION

### Main Switch (Driver Side)

Check for conductivity between the terminals of the switch.

### Power switch

	a	h
OFF		
ON	○—○	

○—○ : Indicates conductive

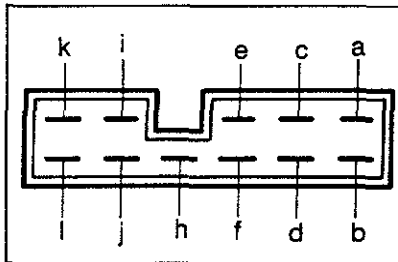

63U15X-145

Switch	Driver side				Passenger side				Rear-right				Rear-left			
terminal	a	b	k	l	a	b	i	j	a	b	e	f	a	b	c	d
wire position	BR	B	RL	G	RB	B	RB	GB	RB	B	RL	GL	RB	B	RW	GW
UP	○—○				○—○				○—○				○—○			
OFF	○—○				○—○				○—○				○—○			
DOWN		○—○				○—○				○—○				○—○		

\* c,d,e and f terminals for 3HB model are not in use

○—○ : Indicates conductive

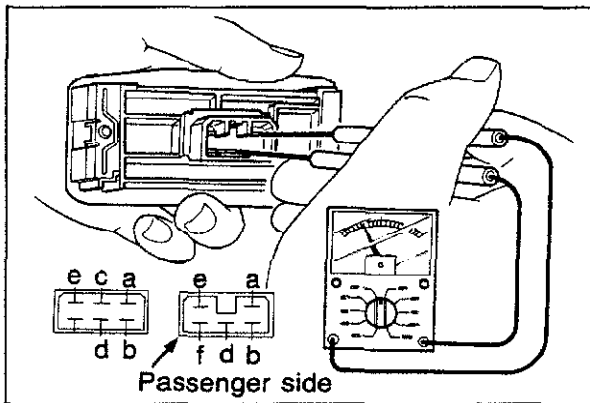

83U15X-094

## Switch on Each Door

Check the conductivity between the terminals.

terminal	a(d)	b(e)	c(f)	d(a)	e(b)
wire position	R	G	RW (RB)	GW (GB)	BL
UP	○—○				○—○
OFF	○—○				
DOWN	○—○				

( ) indicates wire color passenger side.

○—○ : Indicates conductive

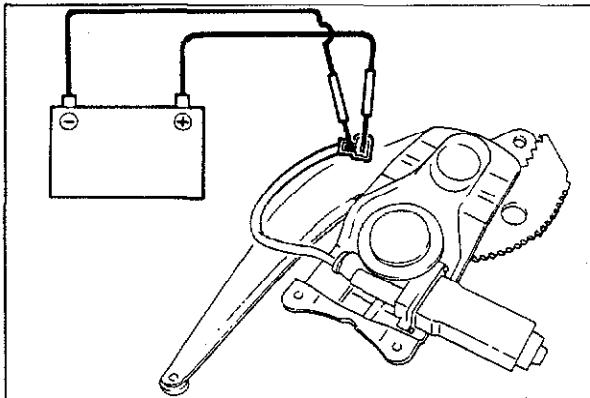

83U15X-095

## Power Window Motor

1. Connect 12V to the "a" terminal and the ground to the "b" terminal of the motor connector, and check that motor operates.
2. Reverse the above connections and check the reverse direction of the motor.



# 15 REMOTE CONTROL MIRROR

## REMOTE CONTROL MIRROR

### STRUCTURAL VIEW

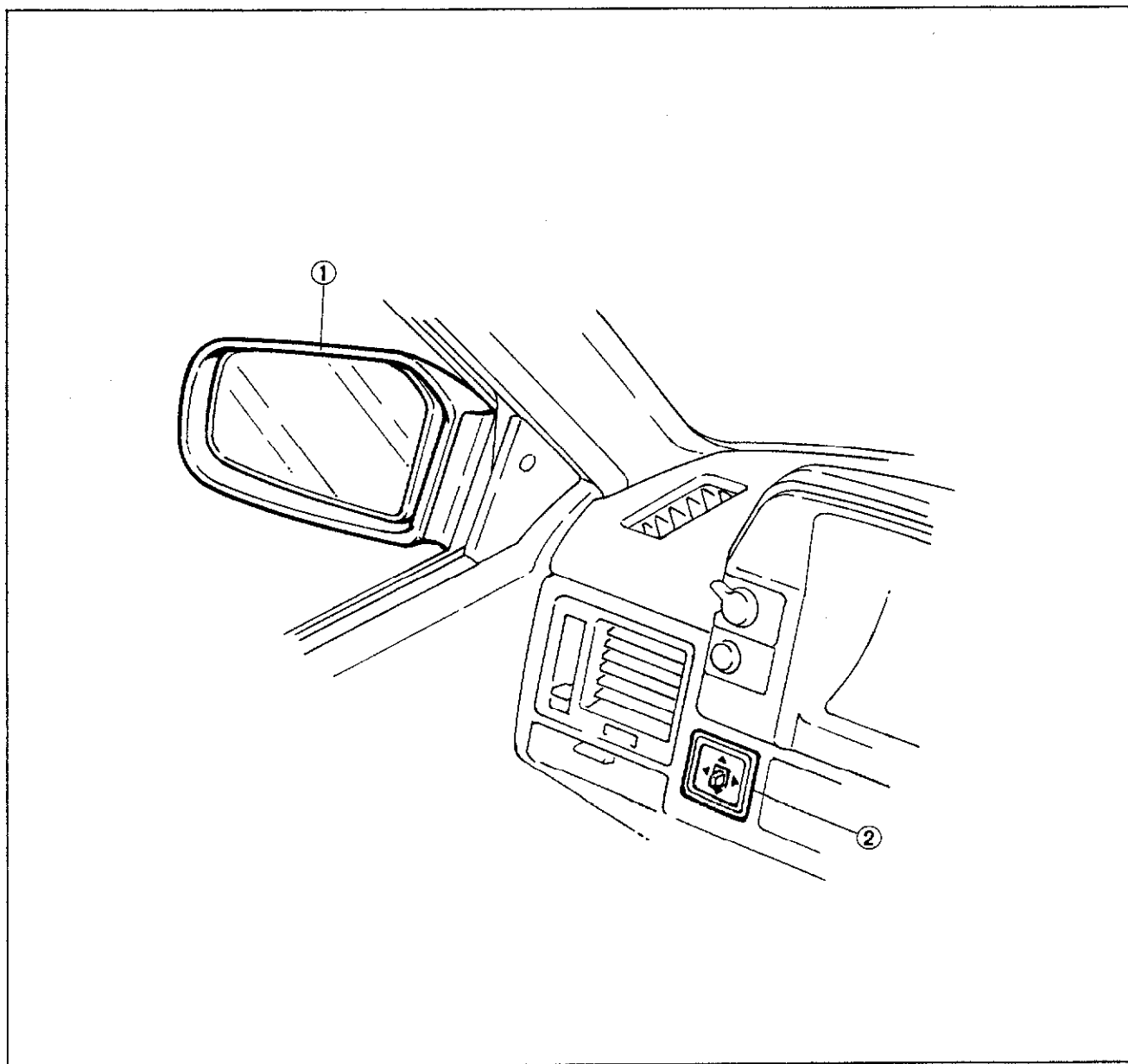

63G15X-048

1. Door mirror

2. Remote control mirror switch

## CIRCUIT DIAGRAM

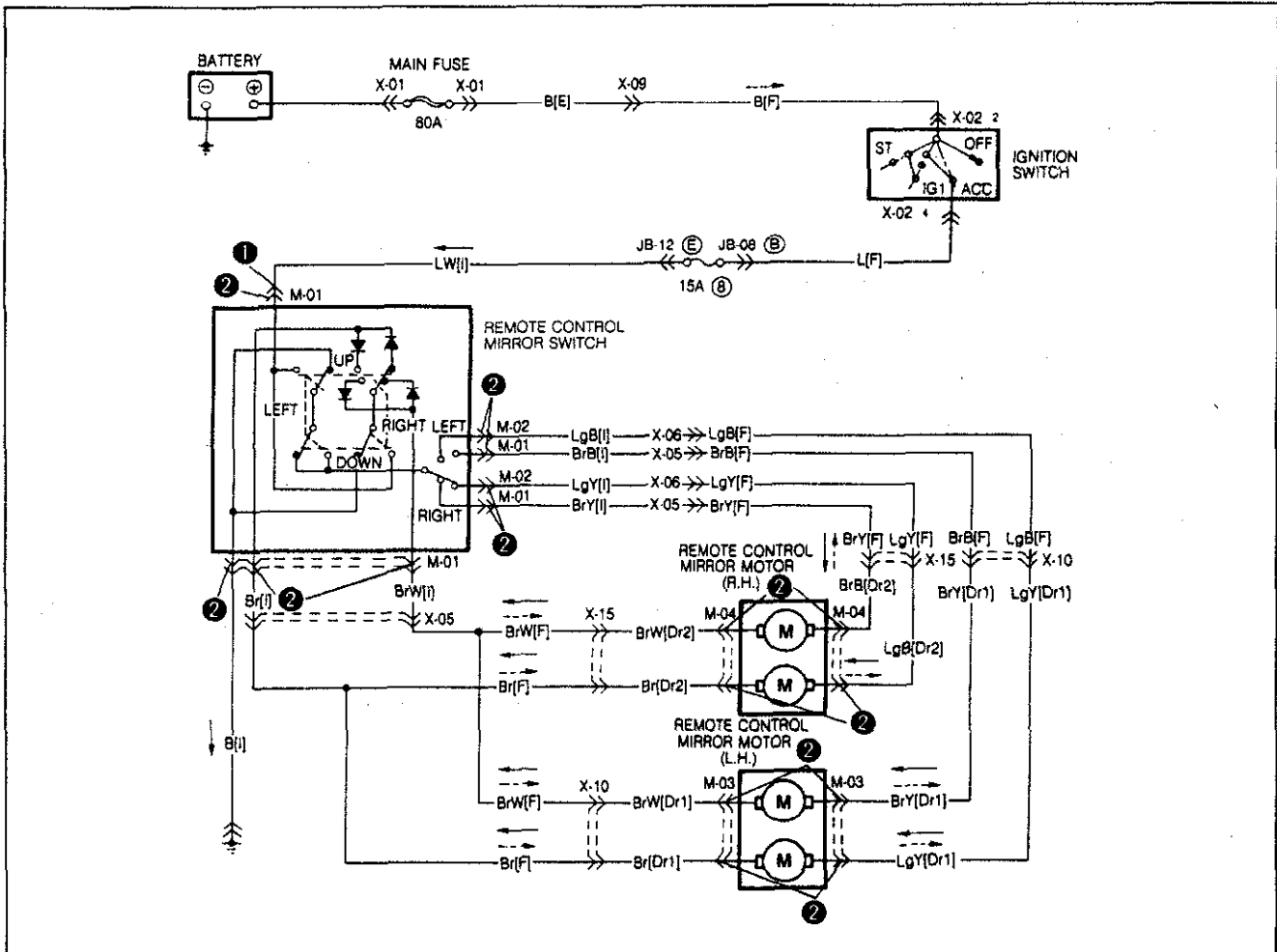

M-01 Remote Control Mirror Switch [I]	M-02 Remote Control Mirror Switch [I]	M-03 Remote Control Mirror Motor L.H. [Dr1]	M-04 Remote Control Mirror Motor R.H. [Dr2]

# 15 REMOTE CONTROL MIRROR

## TROUBLESHOOTING

Remote control mirror does not operate

Check audio fuse 15A

NG Short circuit (Broken wire)

1 Turn Ign switch to ACC. Check for 12V on LW wire of remote control mirror switch connector.

NG Broken LW wire (Fuse-Remote control mirror switch)

2

Check conductivity of the terminals of remote control mirror switch and remote control mirror motor.

### REMOTE CONTROL MIRROR

CLASS	DIRECTION	2 PIN		6 PIN						
		a	b	a	b	c	d	e	f	
LEFT	UP	○	○	○	○	○	○	○	○	○
	DOWN	○	○	○	○	○	○	○	○	○
	LEFT	○	○	○	○	○	○	○	○	○
	RIGHT	○	○	○	○	○	○	○	○	○
RIGHT	UP	○	○	○	○	○	○	○	○	○
	DOWN	○	○	○	○	○	○	○	○	○
	LEFT	○	○	○	○	○	○	○	○	○
	RIGHT	○	○	○	○	○	○	○	○	○

### REMOTE CONTROL MOTOR

Terminal	Conductivity
a - c	Yes
b - d	Yes

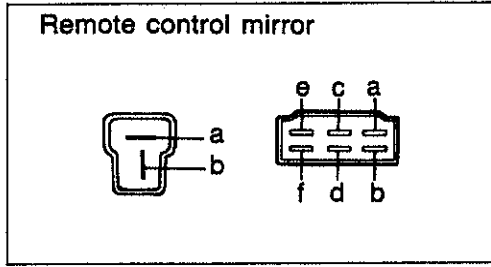

NG Defective remote control mirror switch or remote control mirror motor.

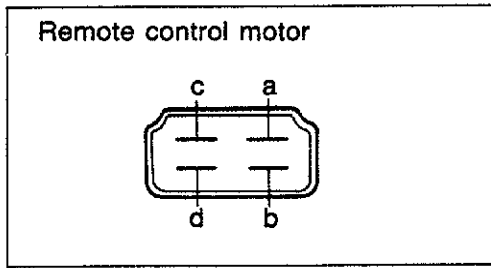

OK Check for wiring between remote control mirror switch and the motor

83U15X-097

ADJUSTABLE SHOCK ABSORBER

STRUCTURAL VIEW

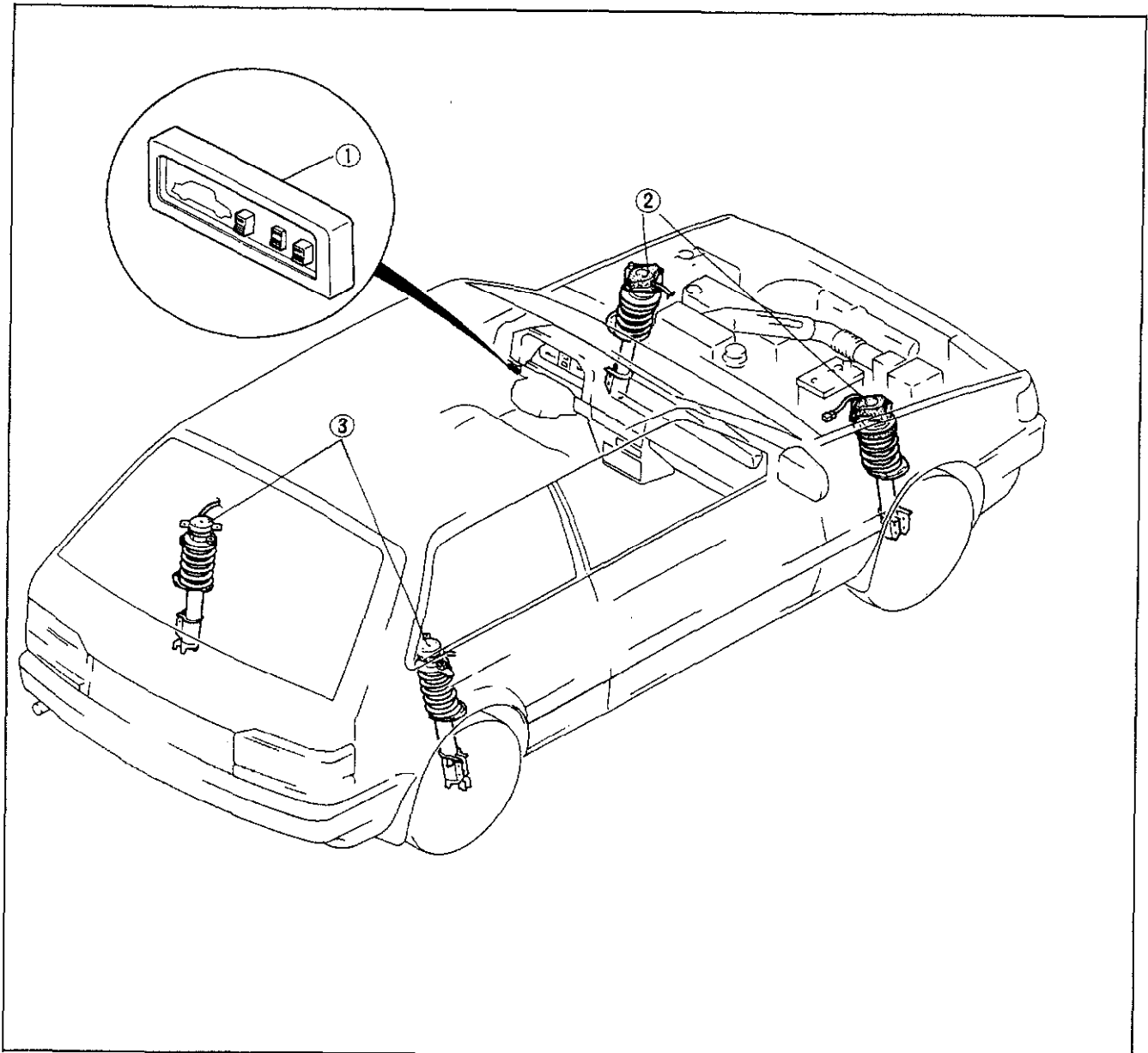

63U15X-148

1. Adjustable shock absorber switch

2. Front actuator

3. Rear actuator

# 15 ADJUSTABLE SHOCK ABSORBER

## CIRCUIT DIAGRAM

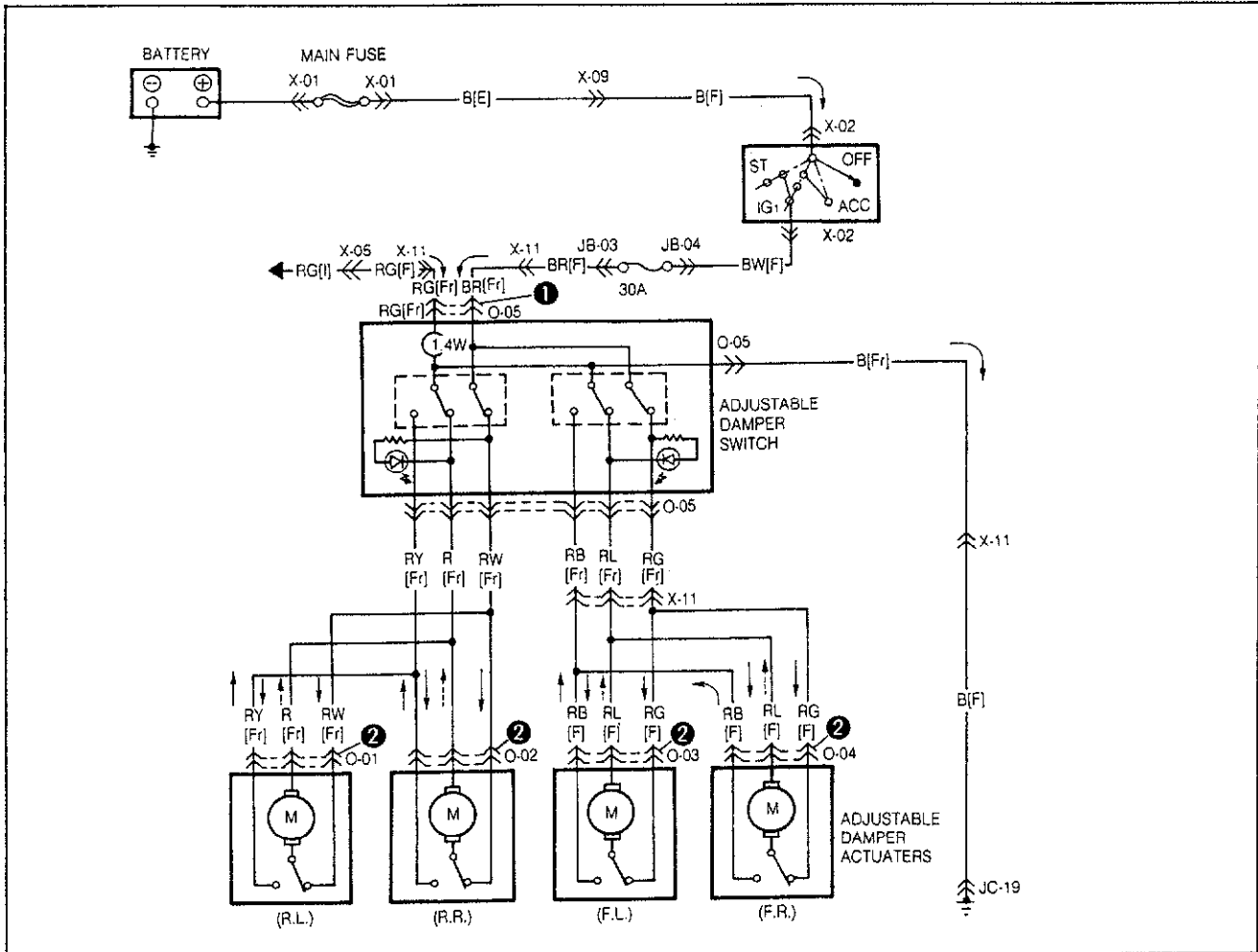

<p>O-01 Adjustable Damper Actuator R.L. [Fr]</p>	<p>O-02 Adjustable Damper Actuator R.R. [Fr]</p>	<p>O-03 Adjustable Damper Actuator F.L. [F]</p>	<p>O-04 Adjustable Damper Actuator F.R. [F]</p>
<p>O-05 Adjustable Damper Switch [Fr]</p>			
Empty row			
Empty row			

83U15X-098

## TROUBLESHOOTING

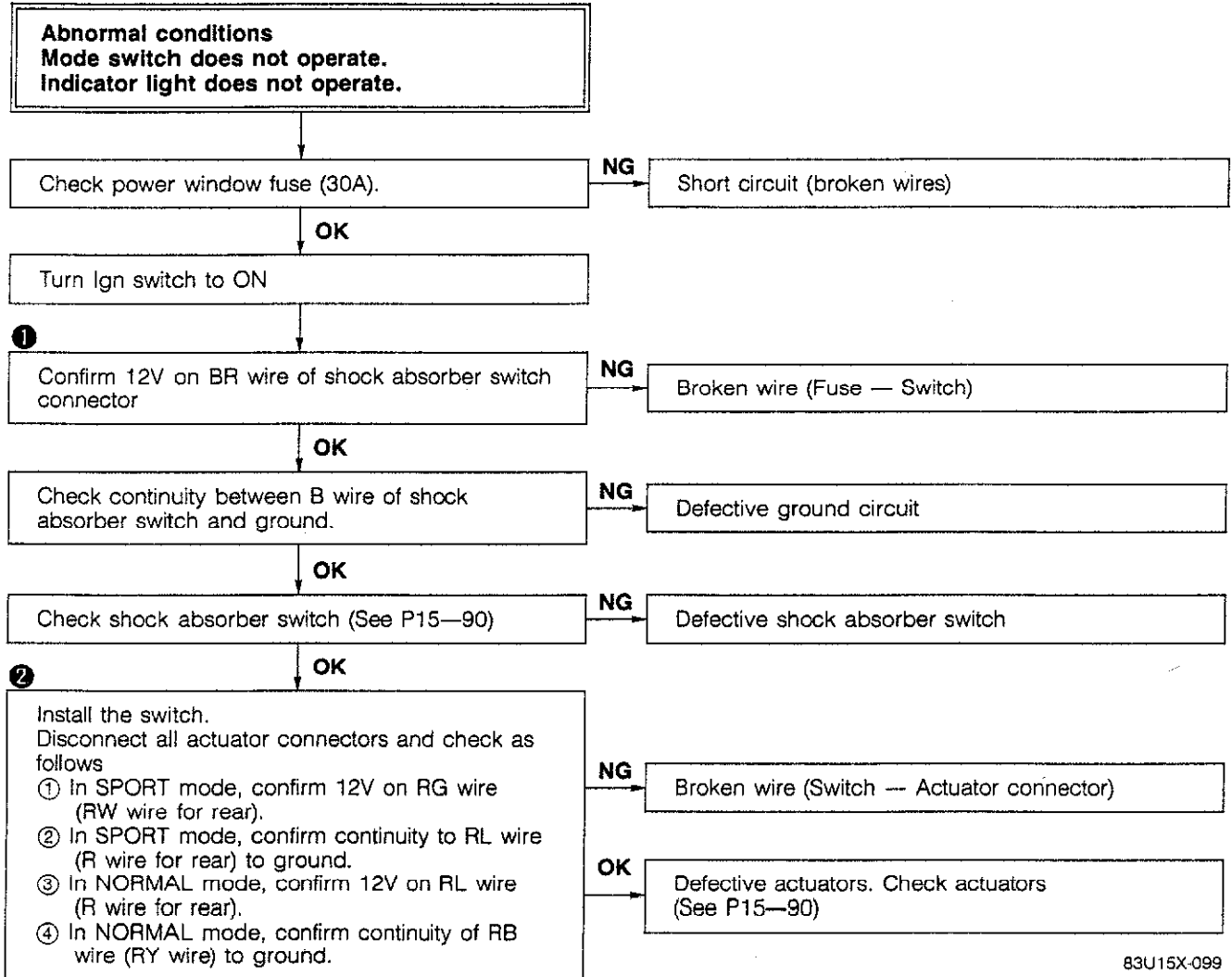

83U15X-099

# 15 ADJUSTABLE SHOCK ABSORBER

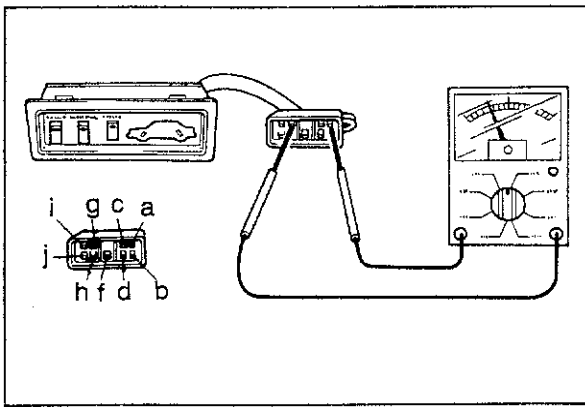

83U15X-100

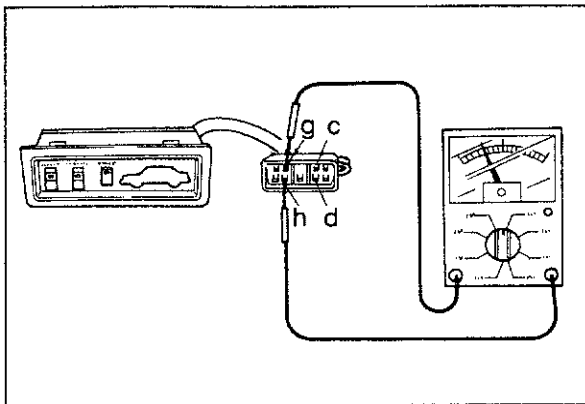

63U15X-152

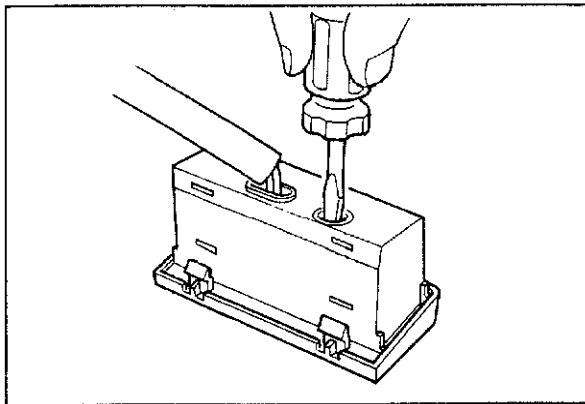

63U15X-153

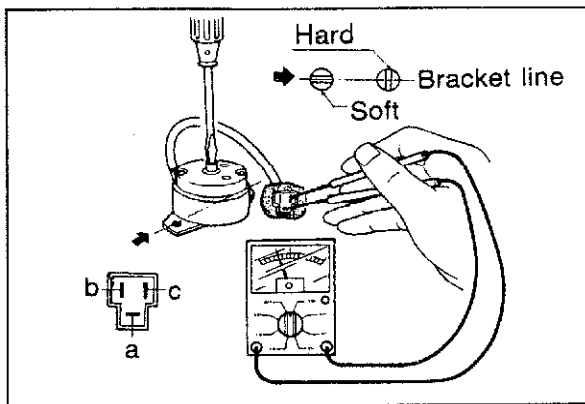

83U15X-101

## INSPECTION

### Adjustable Shock Absorber Switch

1. Confirm continuity between terminals in the three modes.

	a	b	c	d	f	g	h	i	j
SPORT	○		○			○			
NORMAL	○			○			○		
CRUISE	○			○		○			

○—○ : Indicates continuity

2. Check the indicator by using an ohmmeter. Confirm that the tester pointer swings when Tester (—) lead to "g" terminal ("c" terminal for rear) and Tester (+) lead to "h" terminal ("d" terminal for rear) are applied.

Confirm that the tester pointer does not swing when above connection is reversed.

#### Note

Set the tester to  $x1000\Omega$  range.

#### Note

a) Do not disassemble the switch as it is difficult to assemble.

b) Illumination lamp bulb can be removed by pushing it by a small screwdriver (—) through the rear hole.

## Actuator

1. Check that the continuity of "a"—"c" terminals and "b"—"c" terminals while turning the actuator rod are as indicated in the following table:

Mode	Rod slit position	a—c	b—c
Soft	Parallel with bracket line	Conductive	Not conductive
Hard	Perpendicular to bracket line	Not conductive	Conductive

# ADJUSTABLE SHOCK ABSORBER 15

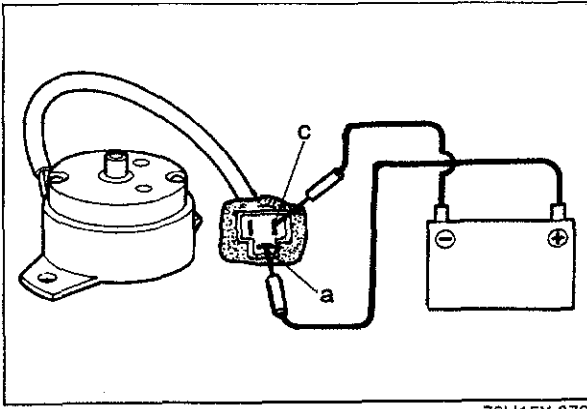

73U15X-078

2. Confirm that in the SOFT mode, the actuator operates when 12V is applied to the "a" terminal and the "c" terminal is grounded.
3. Confirm that in the HARD mode, the actuator operates when 12V is applied to the "c" terminal and the "b" terminal is grounded.

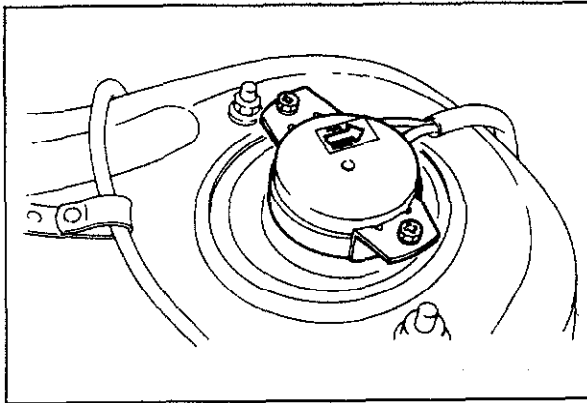

63U15X-156

### Caution

- a) Observe the installation direction of the actuators.
- b) Do not disassemble the actuators.



## CRUISE CONTROL SYSTEM

### STRUCTURAL VIEW

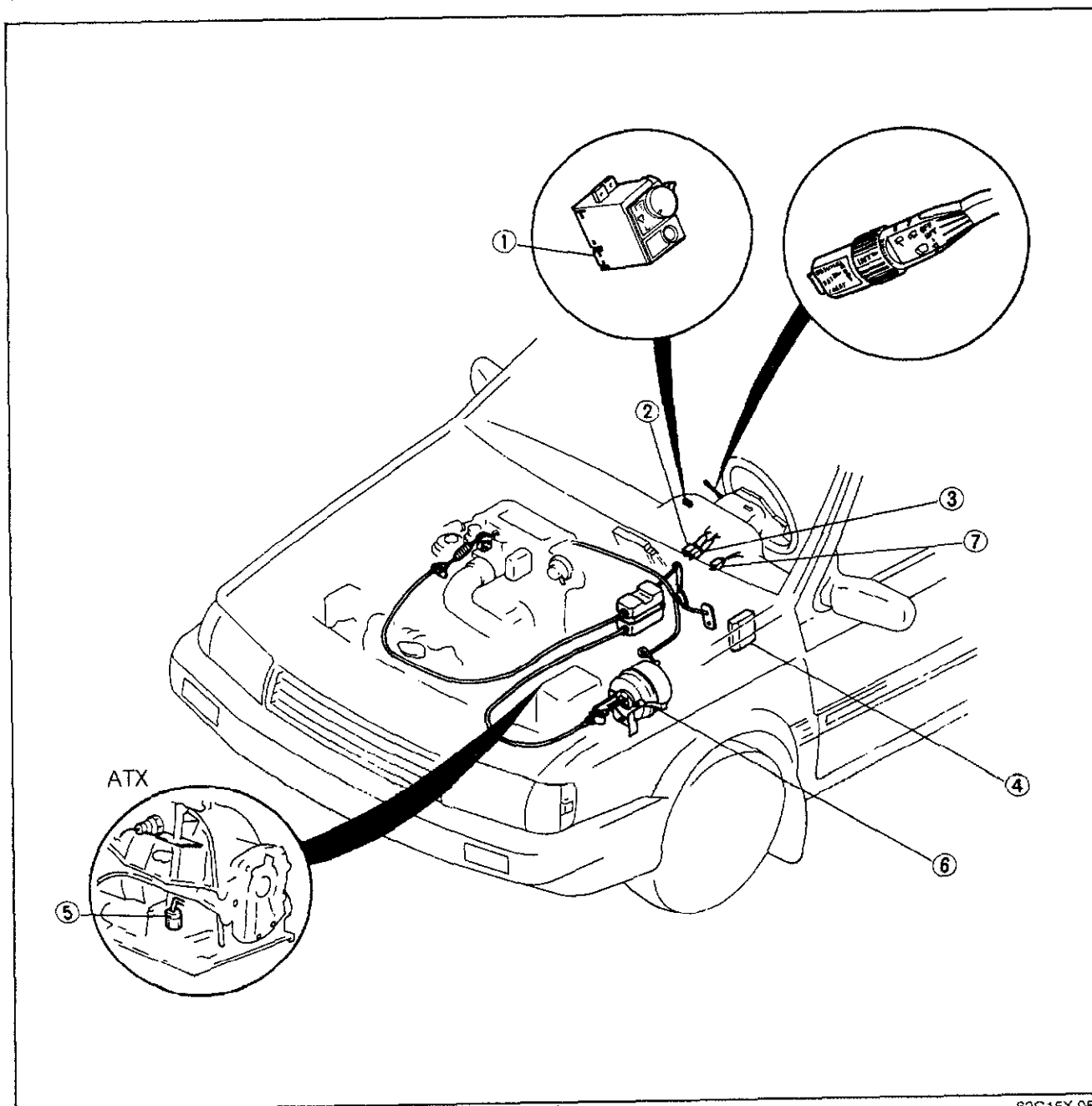

83G15X-054

- 1. Main switch
- 2. Stop light switch
- 3. Stop switch
- 4. Control unit

- 5. Inhibitor switch (ATX)
- 6. Actuator
- 7. Clutch switch (MTX)

## TROUBLESHOOTING GUIDE

Problem	Possible Cause	Remedy	Page
<b>Cruise control system does not work</b>	Meter circuit board open circuit Defective main switch Defective control unit Defective actuator Defective control switch Defective speed sensor Defective clutch switch Defective stop switch Faulty wiring or ground	Replace fuse and check for short Check main switch Check control unit Check actuator Check control switch Check speed sensor Adjust or replace clutch switch Adjust or replace stop switch Repair as necessary	15—97     15—96 15—96 15—96
<b>Speed setting can not be cancelled</b>	Defective control unit Defective clutch switch Defective stop switch	Check control unit Adjust or replace clutch switch Adjust or replace stop switch	15—96 15—96
<b>The set speed is not held</b>	Defective actuator Defective actuator control cable Defective control unit Defective speed sensor	Check actuator Adjust or replace control cable Check control unit Check speed sensor	15—97 15—97
<b>Cruise control system does not function immediately</b>	Defective actuator Defective actuator control cable Defective control switch Defective control unit	Check actuator Adjust or replace control cable Check control switch Check control unit	15—97 15—95

83U15X-102

# 15 CRUISE CONTROL SYSTEM

## ON-VEHICLE INSPECTION (USING ACC CHECKER)

Acc Checker (49 9200 010)

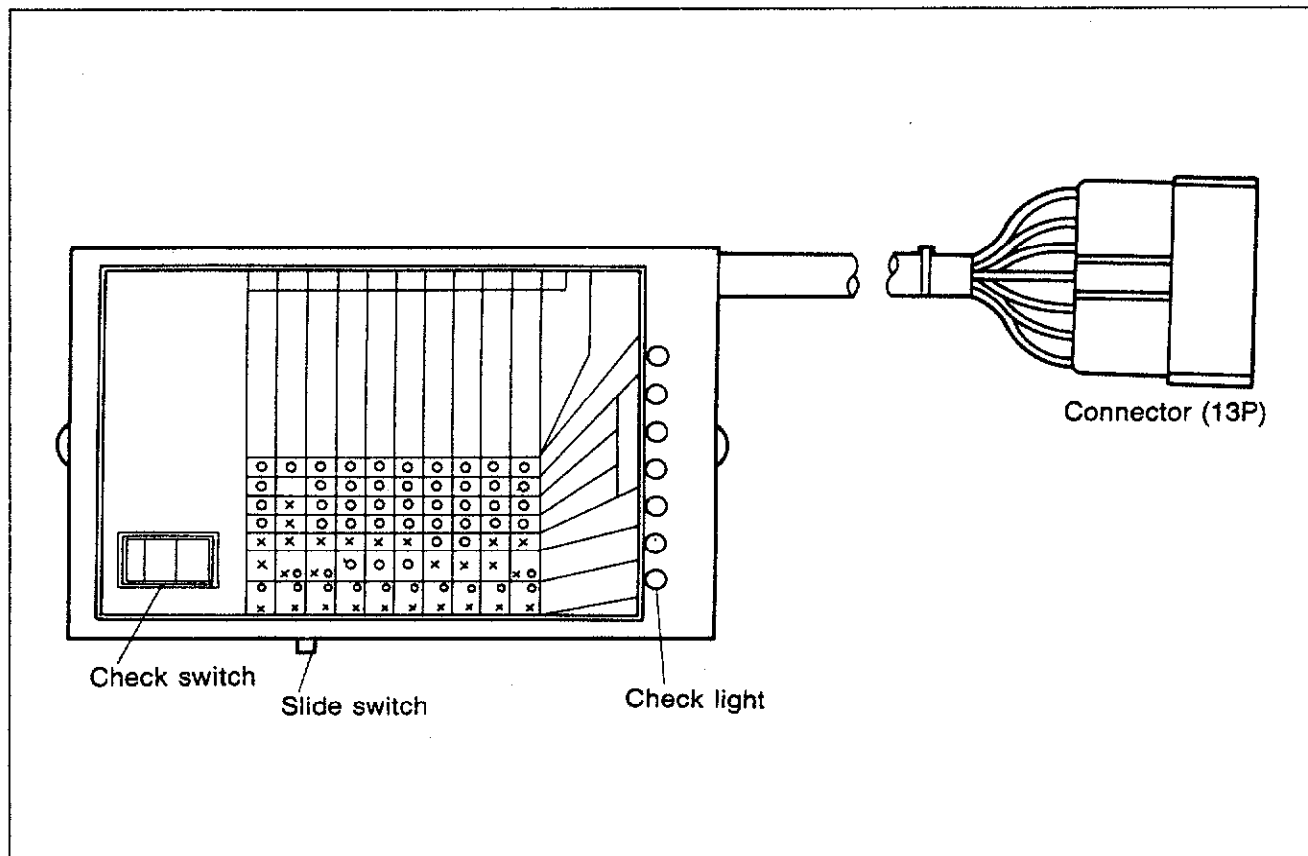

83U15X-103

## Function of the ACC CHECKER

### A. Check Lights

Each item is verified by a check light, as described below.

Check light	Check Items
<b>MAIN SW.</b>	Ignition switch, fuse, main switch and associated wiring harness terminals and connectors.
<b>ACTUATOR—VAC</b>	VAC coil continuity in the actuator and associated harness.
<b>ACTUATOR— VENT 2</b>	VENT 2 coil continuity in the actuator and associated harness.
<b>ACTUATOR-VENT 1</b>	VENT 1 coil continuity in the actuator and associated harness.
<b>CLUTCH/BRAKE SW.</b>	Clutch switch, brake switch and associated harness.
<b>COMBINATION SW.</b>	"SET", "COAST" and "RESUME" position in the combination switch, and associated harness.
<b>GENERATOR</b>	Speed sensor output and associated harness.

73U15X-081

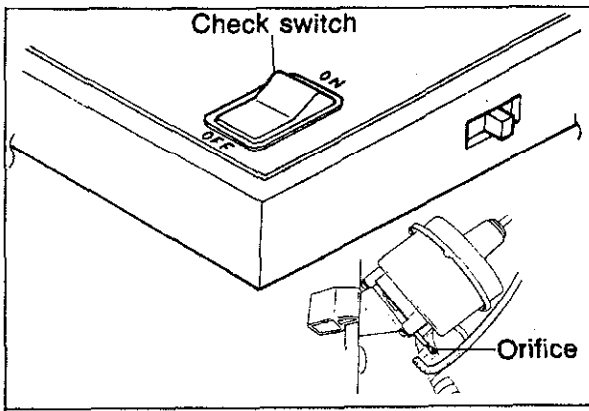

63U15X-159

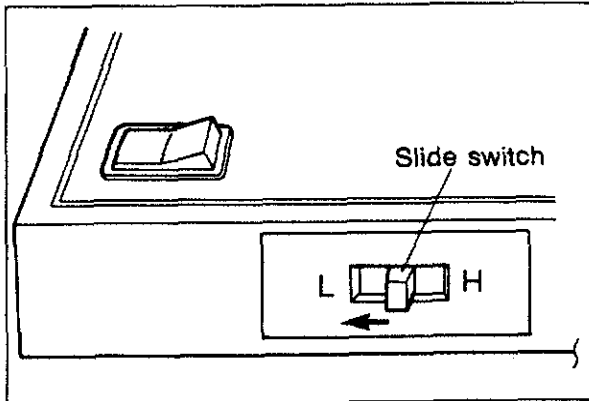

63U15X-160

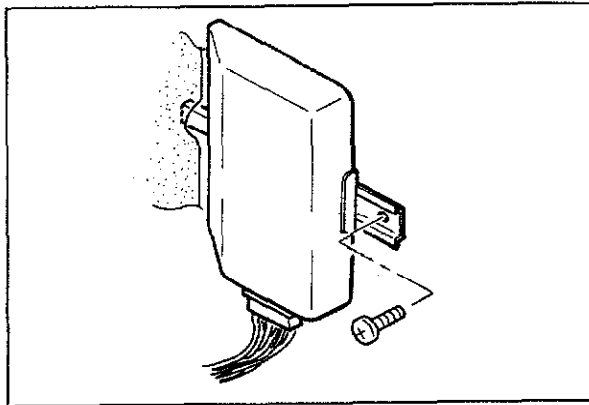

63U15X-161

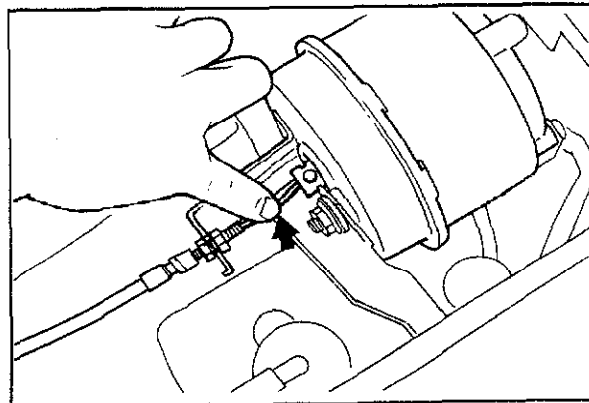

63U15X-163

## B. Check switch

The check switch is provided in the ACC checker to check the actuator operation while the engine is running. When the check switch is held on after the engine is started, the engine speed increases to approximately 2,000 to 3,000 rpm and is maintained at that level. When the check switch is then released, the engine speed decreases to idle speed.

### Note

**Before checking the actuator operation, remove the orifice from the actuator as shown in the figure and reconnect the vacuum hose. Replace the orifice after tests are completed.**

## C. Slide switch

Set the slide switch in the L position before the check switch is used.

Then engine rpm will increase to approximately 2,000 to 3,000 rpm, and will hold steady.

### Note

**If engine rpm does not reach, and remain in the 2,000 to 3,000 rpm range, adjust the freeplay of the actuator inner cable.**

## Preparation

### 1. ACC checker installation

Depress the lock hook of the harness connector. Remove the connector from the ACC control unit after the ignition switch and main switch are turned off, and connect the harness connector to the ACC checker.

### 2. Checking the freeplay of the actuator inner cable

Remove the clip and adjust the nut so that the actuator control cable play is as follows when the cable is pressed lightly.

**1—3 mm (0.04—0.12 in)**

# 15 CRUISE CONTROL SYSTEM

## Checking the System

### Check table

O: Light OFF

X: Light ON

CHECK ITEMS AND CONDITIONS	CHECK LIGHTS (correct response)							TROUBLESHOOTING (INCORRECT RESPONSE)
	MAIN SW.	ACTUATOR			CLUTCH/BRAKE SW.	COMBINATION/INH. SW.	GENERATOR	
		VAC	VENT 2	VENT 1				
1. MAIN SW. CONTINUITY: • Ignition switch ON • Main switch ON	O	O	O	O	X	X	O or X	ALL LIGHTS OFF: Check ignition switch, main switch, fuse, and associated harness terminals and connectors.
2. BRAKE SW. CONTINUITY: • Ignition switch ON • Main switch ON • Depress brake pedal	O	O	O	O	X	X	O or X	CLUTCH/BRAKE SW. LIGHT OFF: Check brake switch and associated harness.
3. CLUTCH SW. CONTINUITY: • Ignition switch ON • Main switch ON • Depress clutch pedal	O	O	O	O	X	X	O or X	CLUTCH/BRAKE SW. LIGHT OFF: Check clutch switch and associated harness.
4. "SET" POSITION OF COMBINATION SWITCH: • Ignition switch ON • Main switch ON • Push to "SET" position of combination switch	O	O	O	O	X	X	O or X	COMBINATION/SW. LIGHT OFF: Check "SET" position of combination switch and associated harness.
5. "COAST" POSITION OF COMBINATION SWITCH: • Ignition switch ON • Main switch ON • Turn to "COAST" position of combination switch	O	O	O	O	X	X	O or X	COMBINATION/SW. LIGHT OFF: Check "COAST" position in combination switch and associated harness.
6. "RESUME" POSITION OF COMBINATION SWITCH: • Ignition switch ON • Main switch ON • Turn to "RESUME" position of combination switch	O	O	O	O	X	X	O or X	COMBINATION/SW. LIGHT OFF: Check "RESUME" position of combination switch and associated harness.

5BU15X-052

CHECK ITEMS AND CONDITIONS	CHECK LIGHTS (correct response)							TROUBLESHOOTING (INCORRECT RESPONSE)
	MAIN SW.	ACTUATOR			CLUTCH/BRAKE SW.	COMBINATION/INH. SW.	GENERATOR	
		VAC	VENT 2	VENT 1				
7. START THE ENGINE • Shift lever in "N" position	○	○	○	○	X	X	○ or X	—
8. ACTUATOR OPERATION: • After engine is started, set the slide switch "L". Then turn "ON" check to switch, and keep in "ON" position  <b>Note:</b> <b>Make sure engine speed increases. If over 4,000 rpm release the switch immediately.</b>	○	X  ○	X	X	X	X	○ or X	If engine speed does not reach and remain in the 2,000 to 3,000 rpm range, defect may be in actuator and associated harness.
9. SPEED SENSOR OUTPUT Jack up front of vehicle and support with stands. Let engine idle in 1st gear.	○	○	○	○	X	X	○ or X	If GENERATOR LIGHT does not flash, defect may be in speed sensor and associated harness.

73U15X-082

### CRUISE CONTROL UNIT

If there is malfunction of the cruise control system, and no abnormal condition is found when ACC checker is used to check items 1 to 9, replace the cruise control unit.

63U15X-164

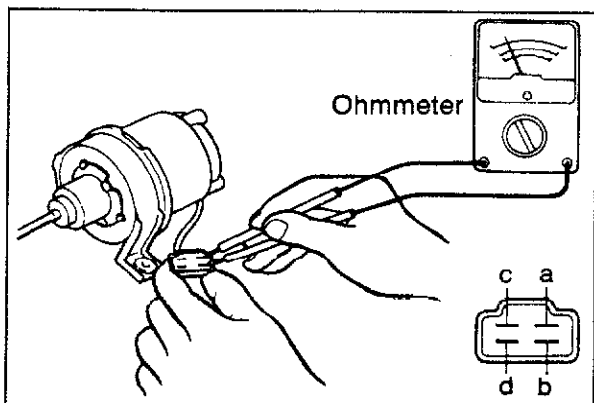

73U15X-083

### Inspection of actuator solenoid

Measure the actuator solenoid resistance using an ohmmeter.

Check terminals	Resistance
c-a	Approx. 25 to 35 ohms
c-b	
c-d	

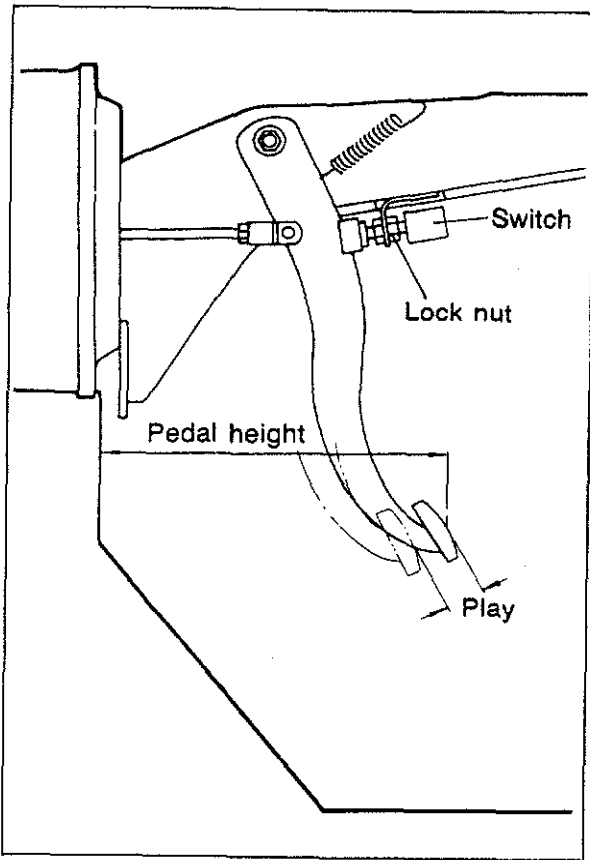

83U15X-104

## CLUTCH SWITCH, BRAKE SWITCH

When replacing these switches, adjust them so that the corresponding pedal height agrees with the standard value.

### Clutch pedal height:

229  $^{+5}_0$  mm (9.02  $^{+0.2}_0$  in).....4WD

214.5  $^{+5}_0$  mm (8.45  $^{+0.2}_0$  in).....Except 4WD

### Brake pedal height:

214  $^{+5}_0$  mm (8.43  $^{+0.2}_0$  in)

## CENTER DIFFERENTIAL LOCK SYSTEM

### STRUCTURAL VIEW

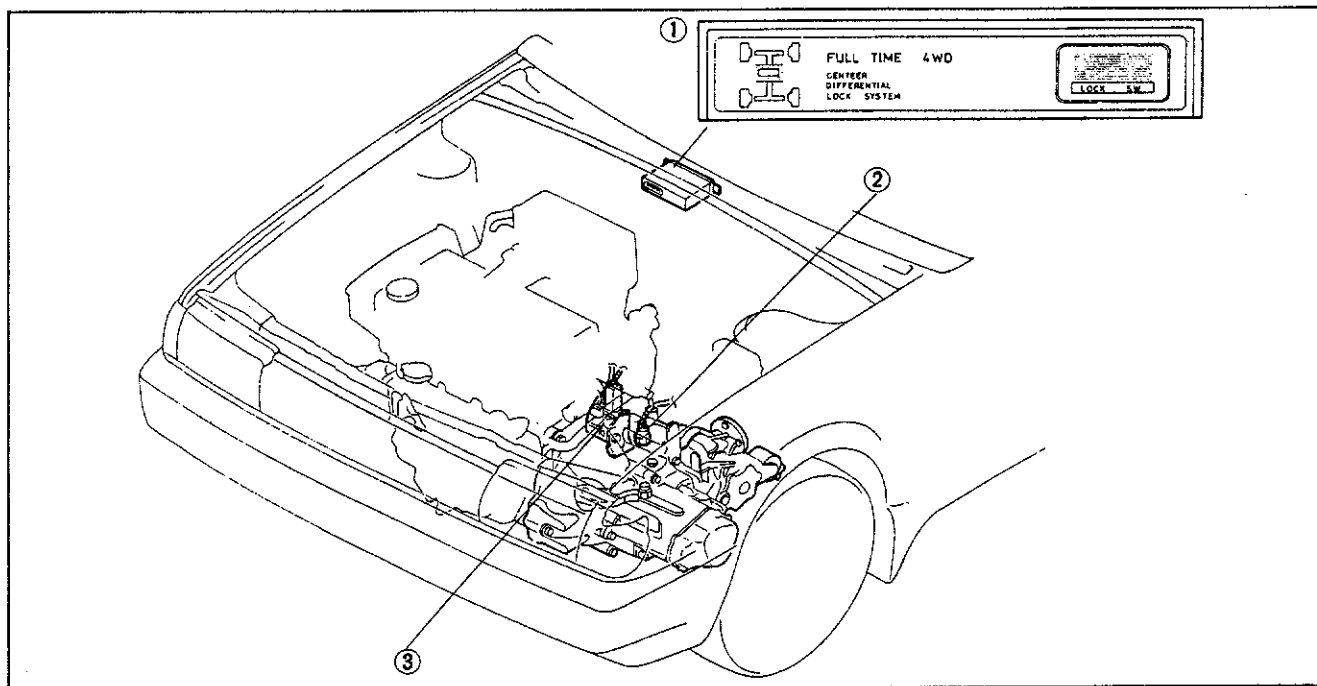

63G15X-323

1. Center differential lock control switch    2. Center differential lock sensor switch    3. Center differential lock sensor

### CIRCUIT DIAGRAM

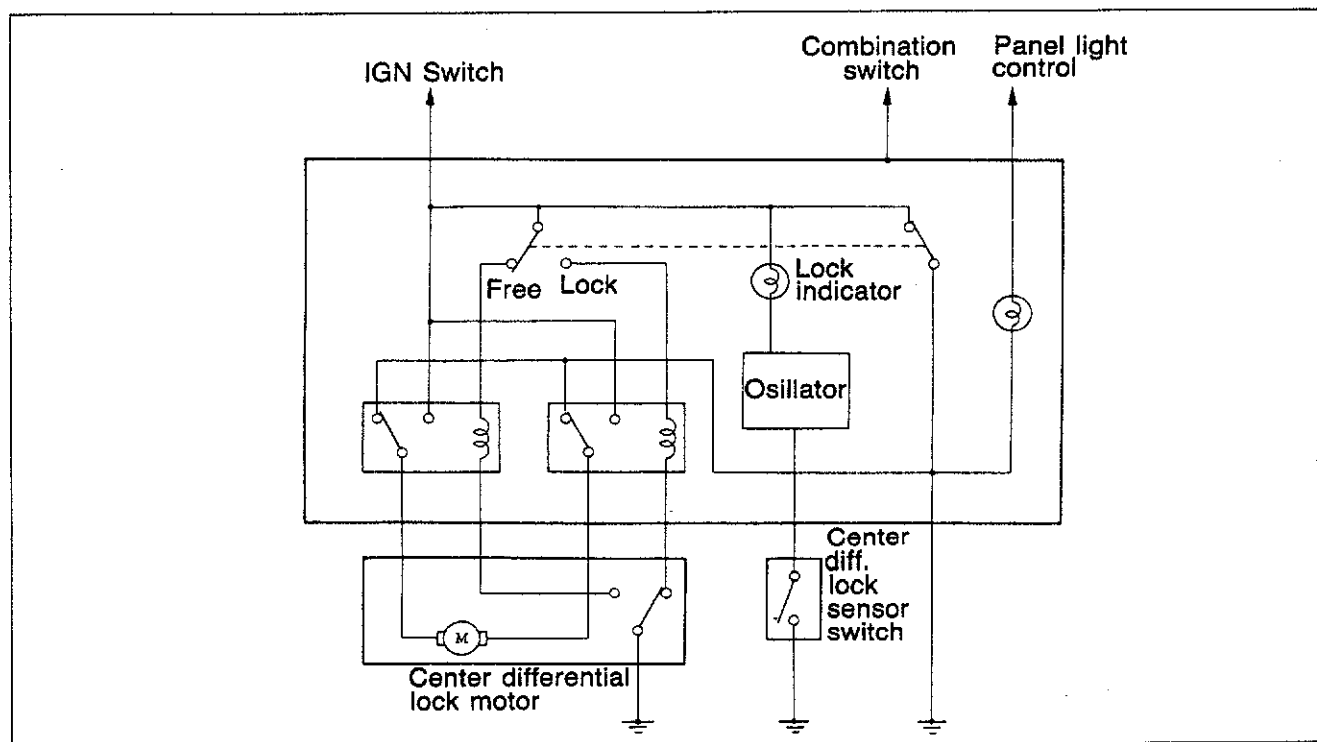

83U15X-105



# 15 CENTER DIFFERENTIAL LOCK SYSTEM

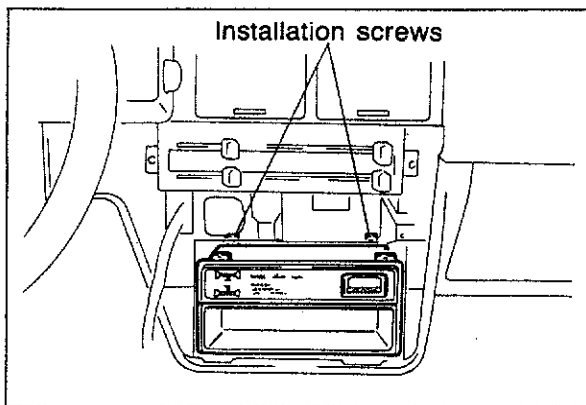

63G15X-325

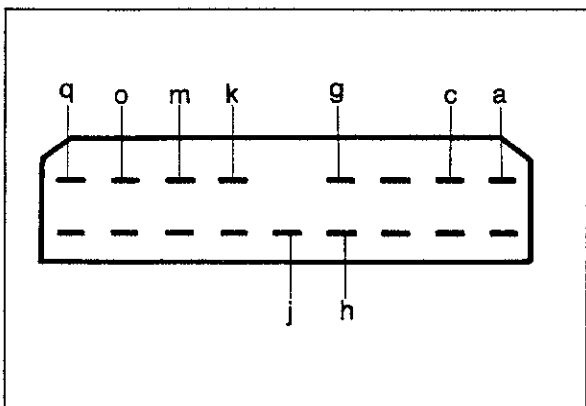

83U15X-106

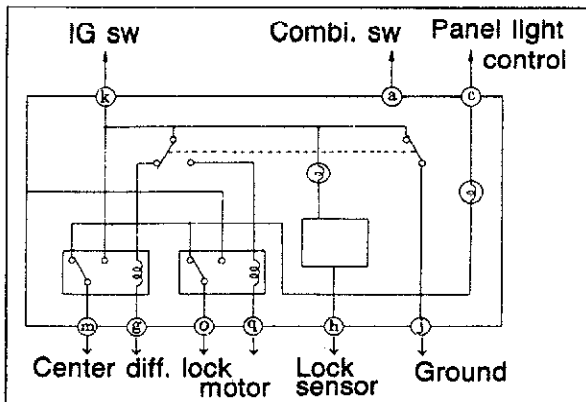

63G15X-327

## CENTER DIFFERENTIAL LOCK CONTROL SWITCH

### Removal

1. Disconnect the negative battery cable.
2. Remove the ashtray and cigarette lighter.
3. Remove the fixing screws.
4. Remove the center panel.
5. Remove the fixing bolts.
6. Remove the center differential lock switch.

### Checking the center differential lock control switch

1. Remove the center differential lock control switch.
2. Turn the IGN switch to ON.
3. Using a voltmeter, check the voltage of each terminal when switching from FREE to LOCK and back.

Unit Volt

	a	c	g	h	j	k	m	o	q
	RB	RG	BG	LO	B	LB	BR	BW	BY
FREE to LOCK			0	6→ 0	0	12	0	12→ 0	0→ 12
LOCK to FREE			0→ 12	0	0	12	12→ 0	0	0

### Installation

Install in the reverse order of removal.

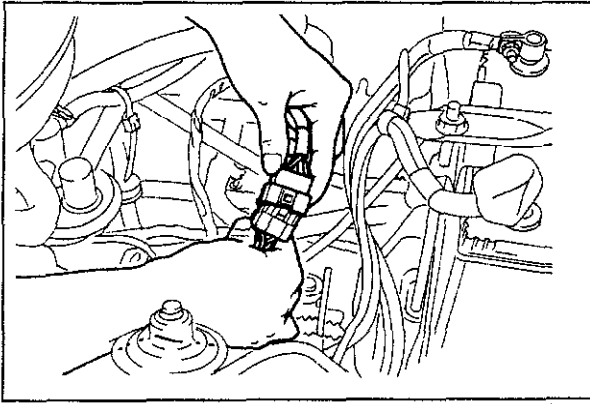

63G15X-328

## CENTER DIFFERENTIAL LOCK MOTOR Removal

1. Disconnect the negative battery cable.
2. Disconnect the lock motor connector and bleazer hose.

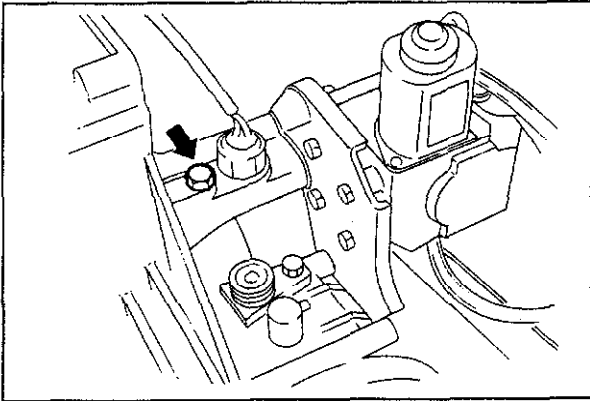

63G15X-329

3. Remove the lock bolt of the rack.
4. Remove the pad of the motor side.

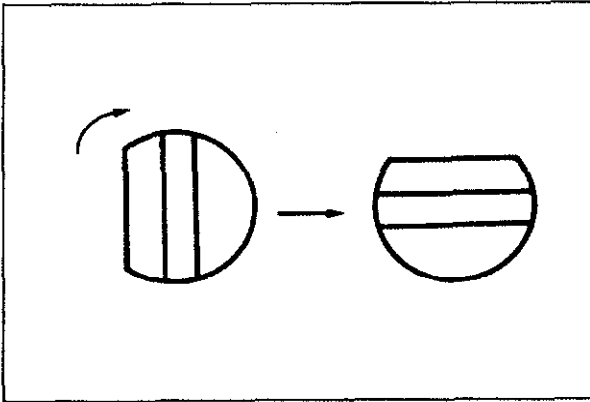

63G15X-330

5. Turn rack to the right using standard screw driver.

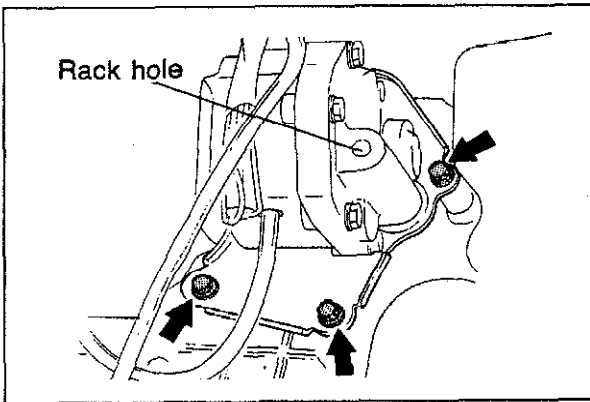

63G15X-331

6. Remove the lock bolts and then remove the lock motor.
7. Remove the O ring from the lock motor.

# 15 CENTER DIFFERENTIAL LOCK SYSTEM

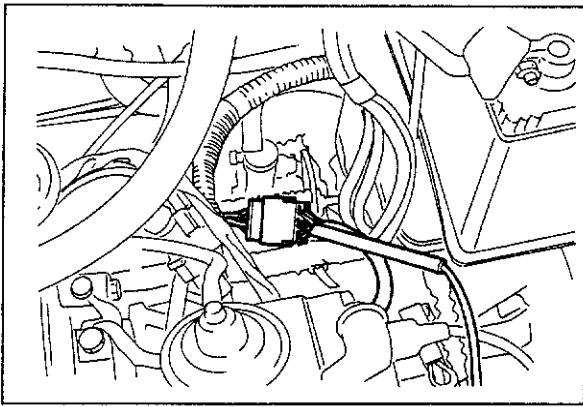

63G15X-331

## System check the motor

- Using a voltmeter, check the voltage of each terminal at the motor connector side when switching from FREE to LOCK and back.

Unit: Volt

	a	b	d	e	f
	G	O	B	W	L
FREE to LOCK	0	0→ 12	0	12→ 0	0
LOCK to FREE	0	0	0→ 12	0	12→ 0

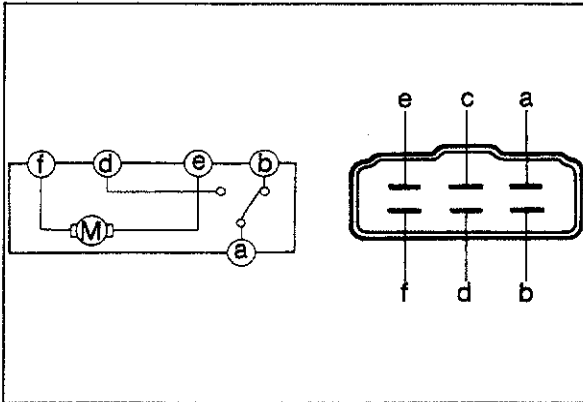

63G15X-333

## Checking the motor

- Disconnect the negative battery cable.
- Disconnect the connector of the center differential lock motor.
- Using an ohmmeter, check the resistance between the terminals at the motor connector side in FREE and LOCK position.

Unit: Ω (ohm)

Motor	a—b	a—b	e—f
FREE	(∞)	0	Approx. 1
LOCK	0	(∞)	

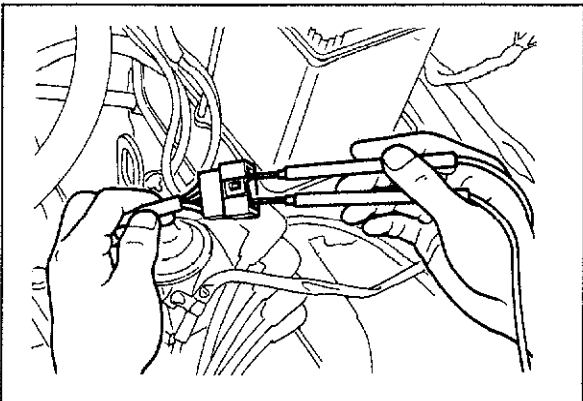

63G15X-334

## Installation

- Measure the rack length in FREE and LOCK position.

### Standard length

72 mm (2.83 in) in FREE

78 mm (3.07 in) in LOCK

### Note

In case of LOCK position, change in FREE position depressing the rack.

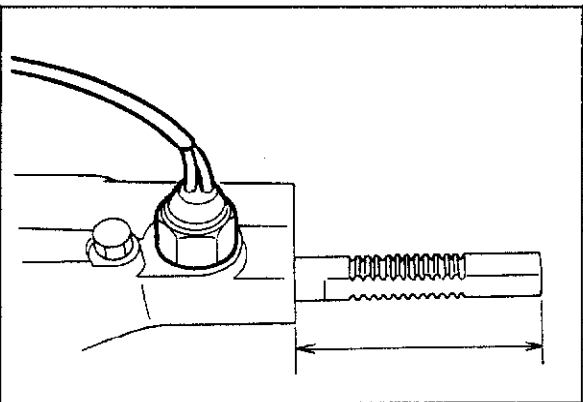

63G15X-335

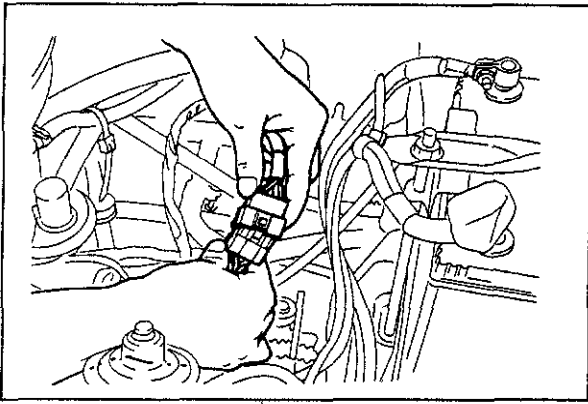

63G15X-336

2. Connect the lock motor connector to the body harness and change in FREE position switching the control switch.

**Note**

**Confirm that the motor rotates when switching the control switch.**

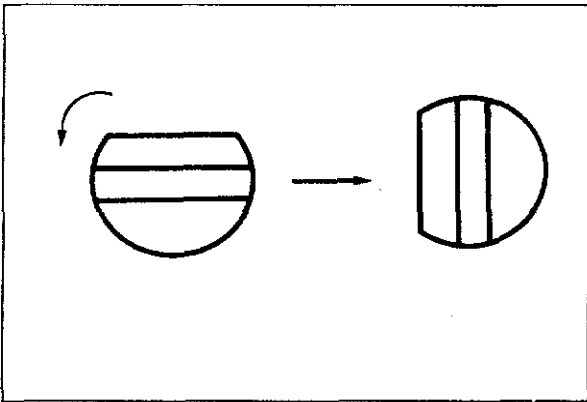

63G15X-337

3. Confirm that the flat edge of the rack locates on the top face.
4. Install the lock motor after applying genuine gear oil to the O ring.
5. Tighten the lock bolts.

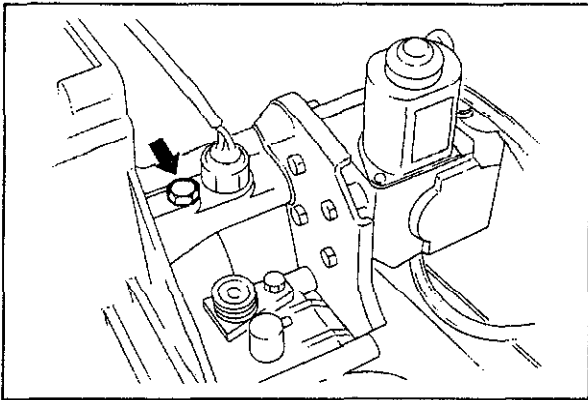

63G15X-338

6. Turn rack to the left using standard screw driver.
7. Install the pad to the motor side.
8. Install the lock bolt.

**Note**

**When the lock bolt can not be installed, adjust the rack position with rotation.**

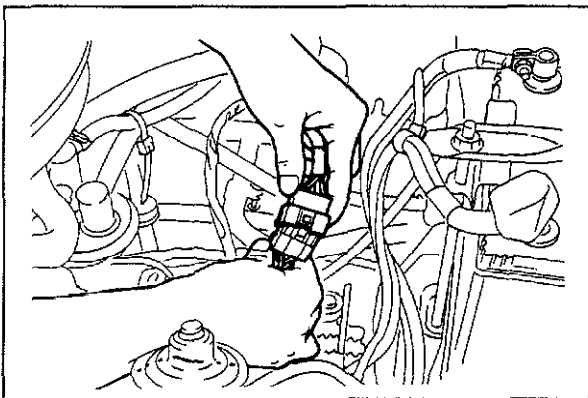

63G15X-339

9. Connect the lock motor connector and bleeder hose.
10. Connect the negative battery cable.

# 15 CENTER DIFFERENTIAL LOCK SYSTEM

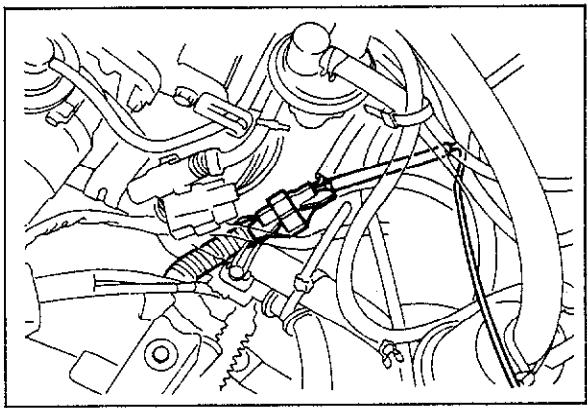

63G15X-340

## CENTER DIFFERENTIAL LOCK SENSOR SWITCH

### System check the sensor switch

Using a voltmeter, check the voltage of each terminal at the switch connector side in FREE and LOCK position.

Unit: Volt

	a	b
	LO	B
FREE	0	0
LOCK	*6 → 0	0

\* When switching, there is a case that transaxle does not change from FREE to LOCK at once.

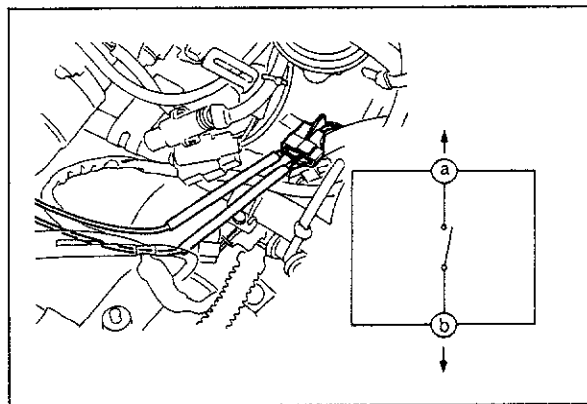

63G15X-341

### Checking the sensor switch

1. Disconnect the negative battery cable.
2. Disconnect the connector of the switch.
3. Using an ohmmeter, check continuity between (a) and (b) terminals at the FREE and LOCK position.

	a	b
	LO	B
FREE		
LOCK	○—○	○—○

○—○ Indicates continuity

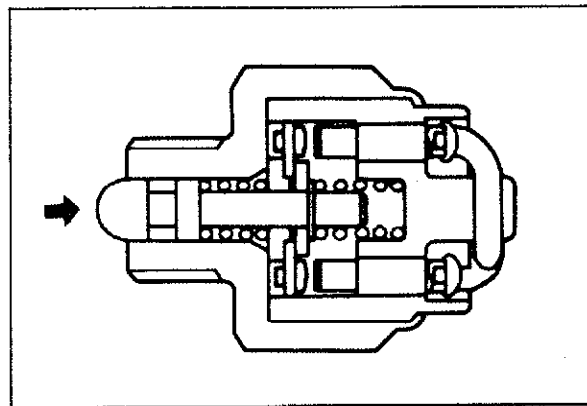

63G15X-342

4. Disconnect the connector of the sensor switch.
5. Remove the sensor switch.
6. Using an ohmmeter, check continuity between (a) and (b) terminals when the rod is the extended or depressed position.

	a	b
	LO	B
Rod		
Extended		
Depressed	○—○	○—○

○—○ Indicates continuity

REAR WINDOW DEFROSTER

STRUCTURAL VIEW

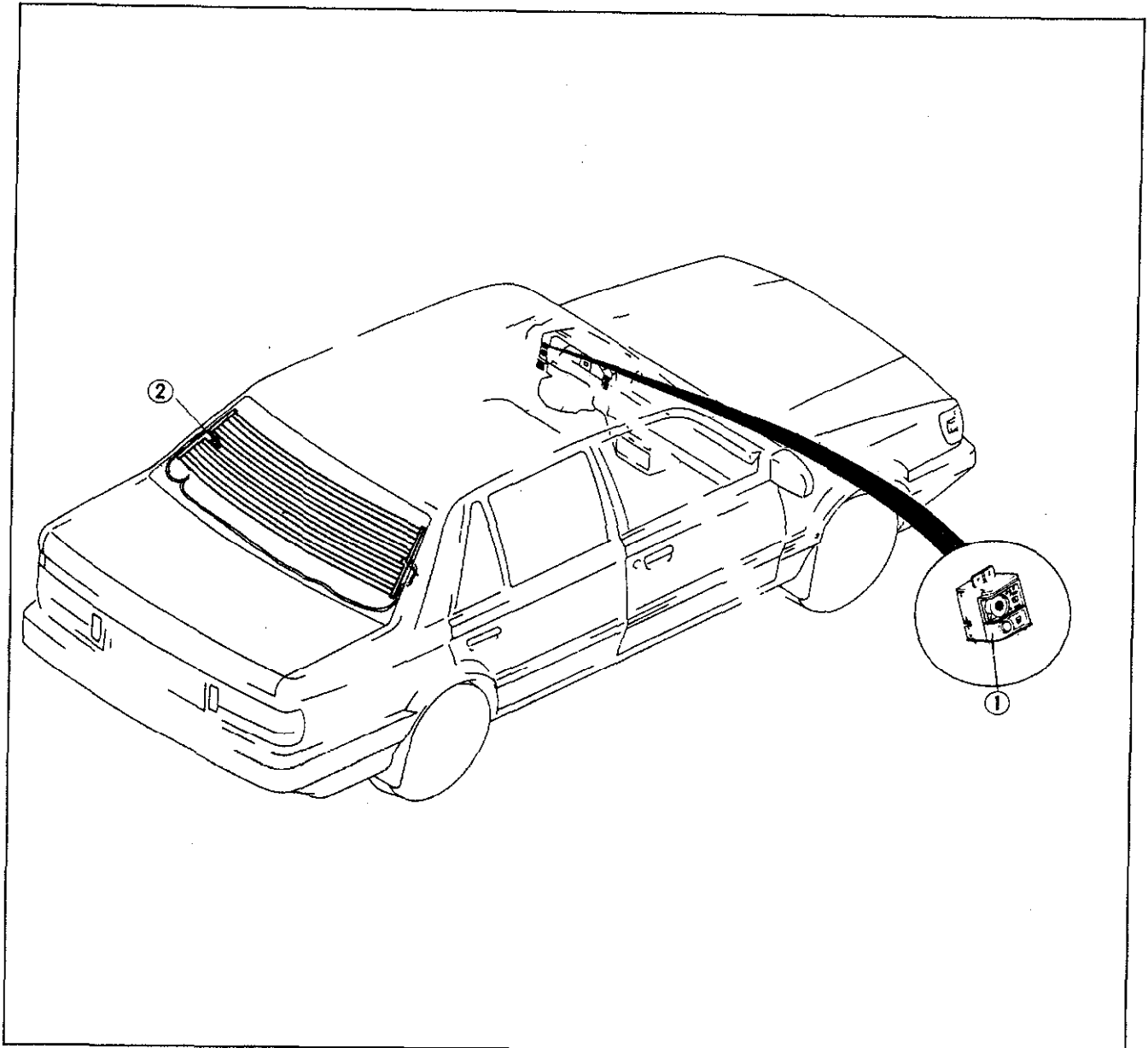

63U15X-167

1. Rear window defroster switch

2. Rear window defroster

# 15 REAR WINDOW DEFROSTER

## CIRCUIT DIAGRAM

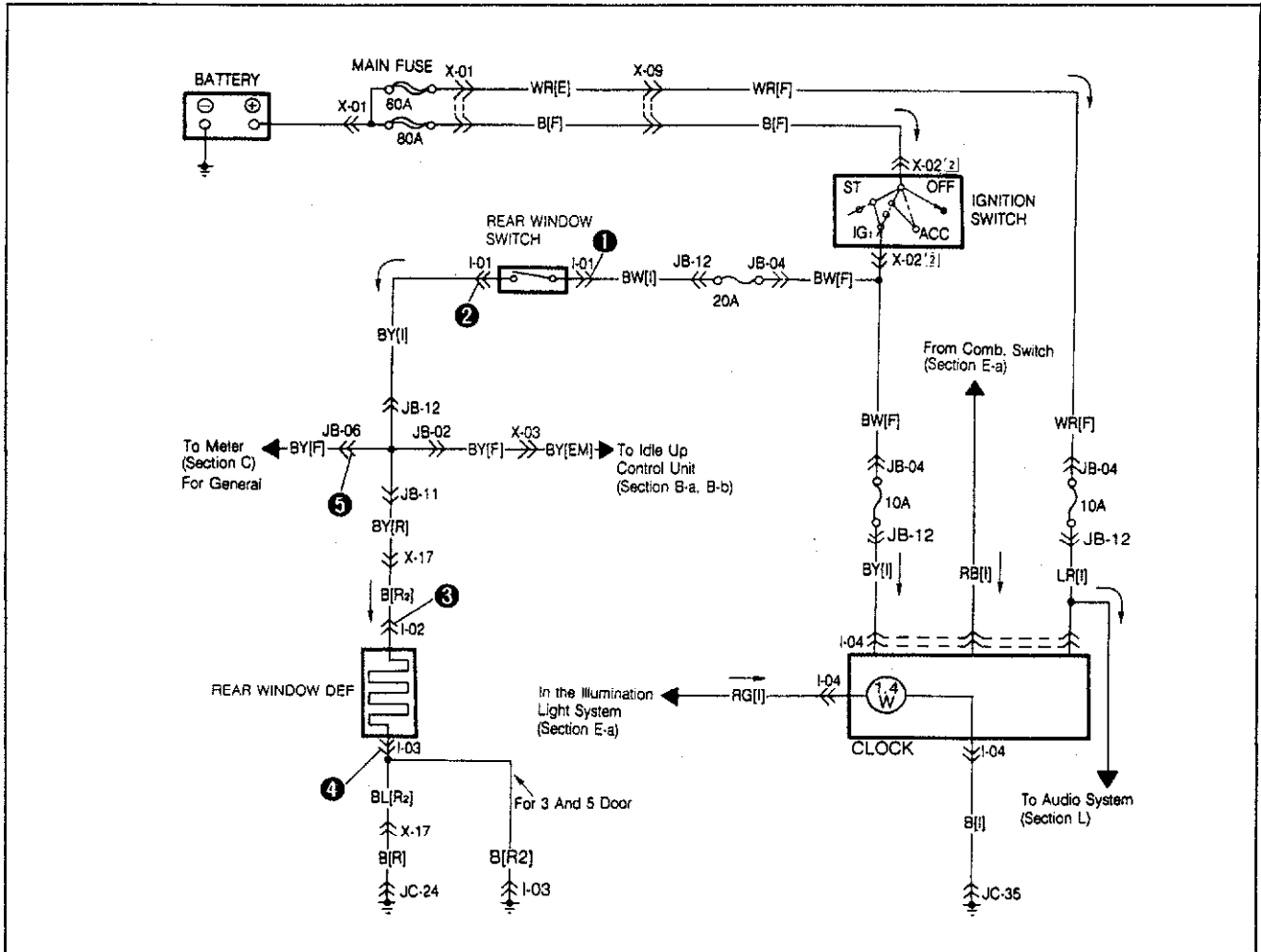

<p>I-01 Rear Window Defroster Sw [I]</p>	<p>I-02 Rear Window Defroster [R2]</p>	<p>I-03 Rear Window Defroster [R2]</p>	<p>I-04 Clock [I] (E-06)</p>
<p>X-24 Meter [F]</p>			

## TROUBLESHOOTING

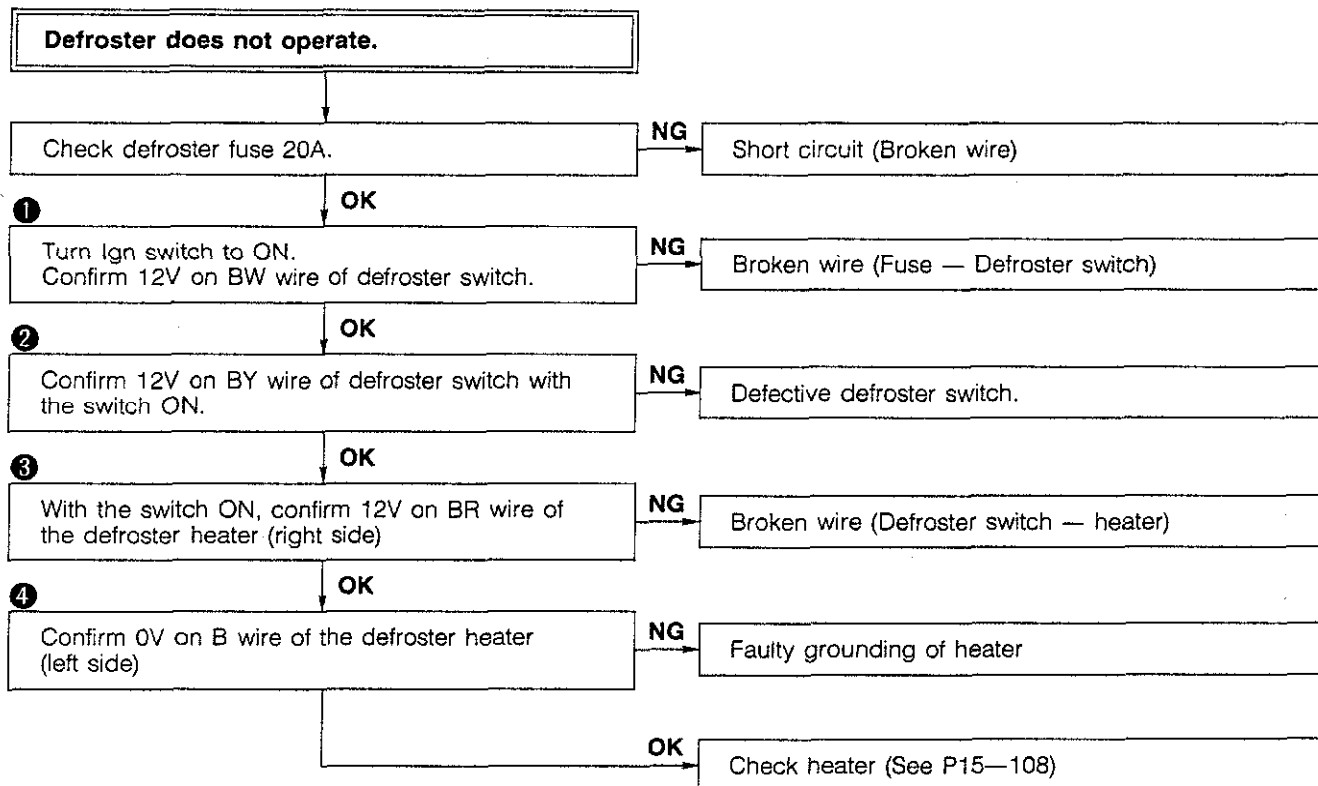

83U15X-108

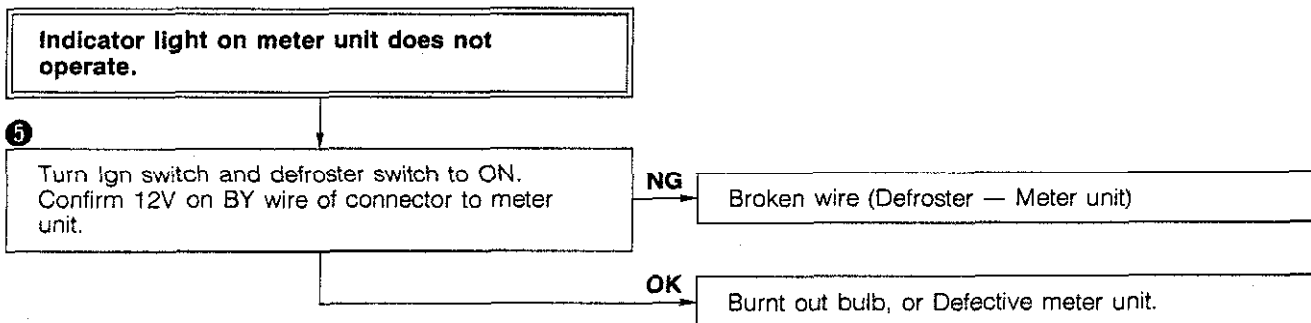

83U15X-109



# 15 REAR WINDOW DEFROSTER

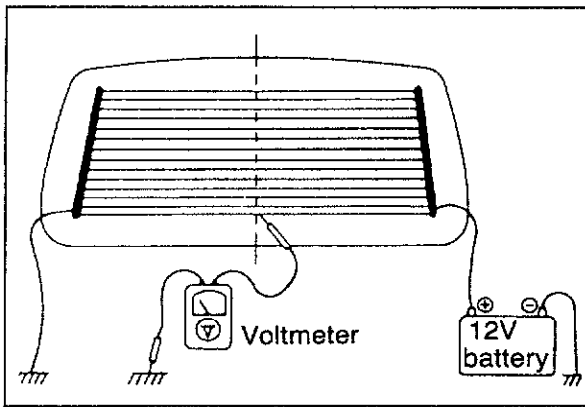

63U15X-171

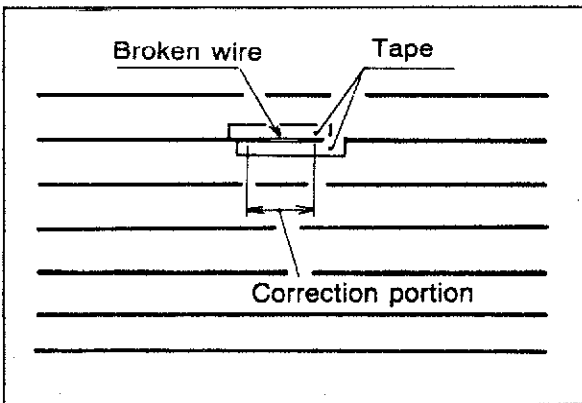
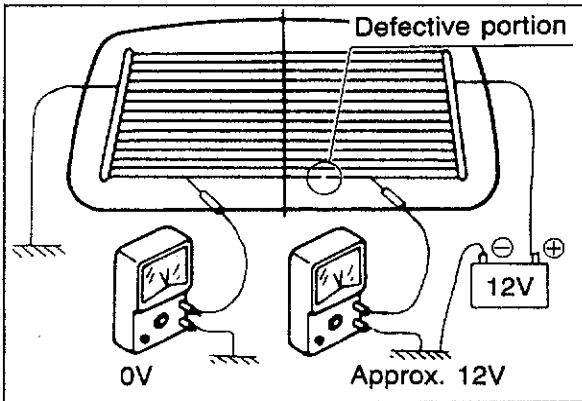

63U15X-172

## INSPECTION

1. Turn the rear-window defroster switch ON.
2. Connect the + terminal of the voltmeter to the center of each filament and the — terminal to the body. The standard voltage at the center of each filament is approximately 6V. If the meter indication is high, there is a short circuit between the center and the grounded side of the filament. If the indication is low or zero, the malfunction is between the center and positive side.

## Repairing the Filament

1. Use paint thinner or ethyl alcohol to clean the damaged part of the filament.
2. Attach tape to both sides of the damaged part of the filament.
3. Using a small brush or marking pen, coat the damaged part with silver paint (part no. 2835 77 600) or equivalent.
4. Let paint set for 24 hours at 20°C (68°F) to let it dry completely. (If a blow dryer is used to heat it to 60°C (140°F), it can be dried in about 30 minutes.)

## Note

- a) Do not use the rear-window defroster until the paint is dry.
- b) Do not use gasoline or similar solvents to clean the damaged part.

## HEATER

### STRUCTURAL VIEW

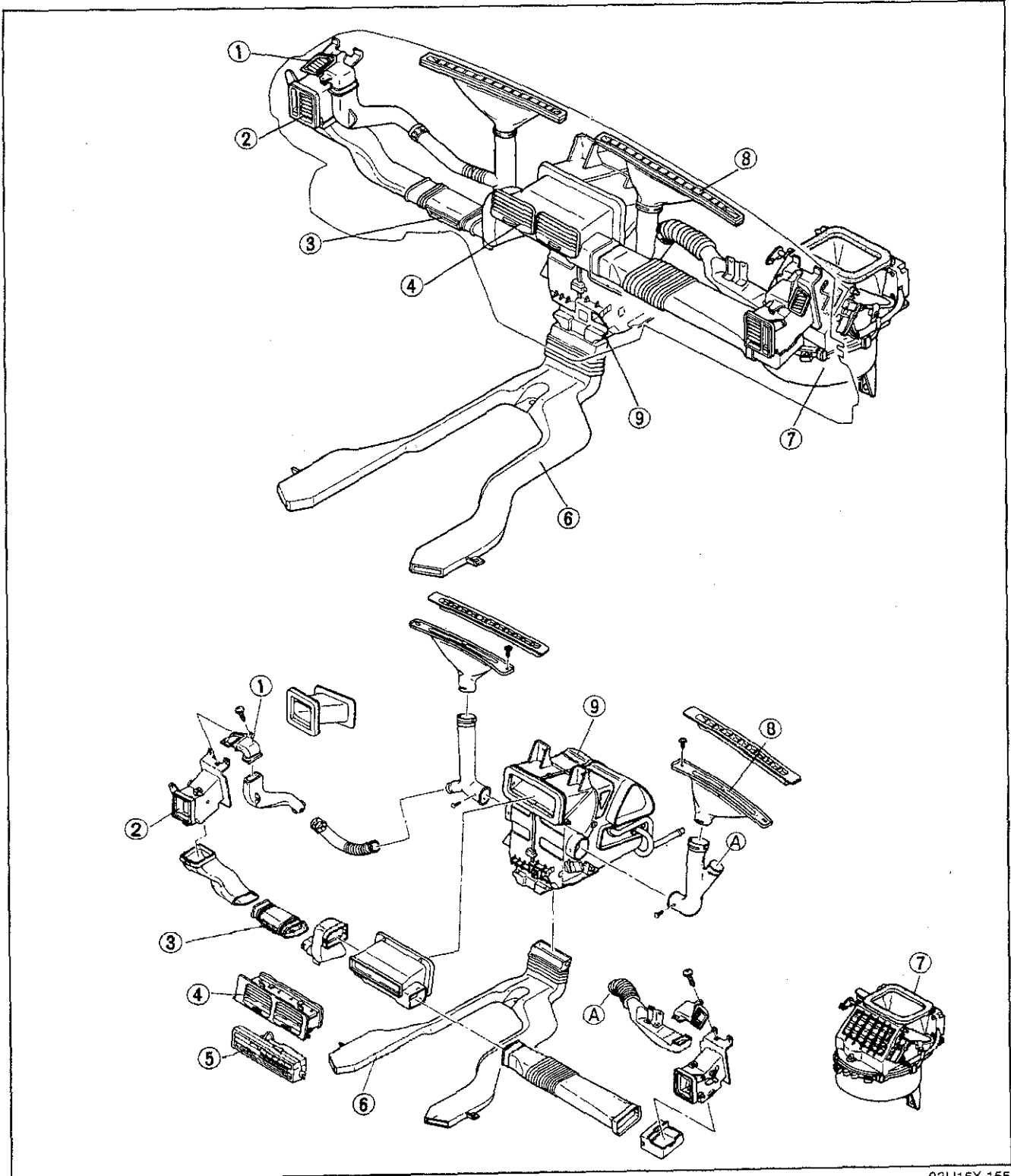

83U15X-155

- 1. Side defroster outlet
- 2. Side louver air outlet
- 3. Lower louver

- 4. Center louver air outlet
- 5. Heater control switch
- 6. Rear heater duct

- 7. Blower unit
- 8. Front defroster air outlet
- 9. Heater unit

## VENT

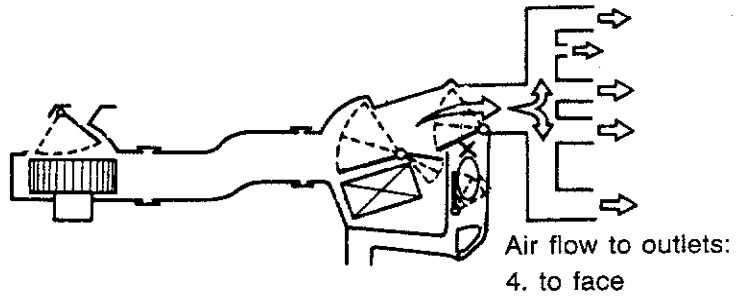
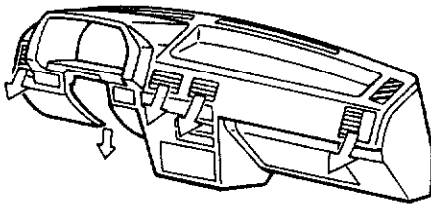
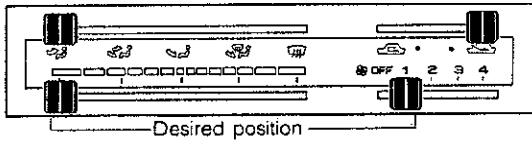

## BI-LEVEL

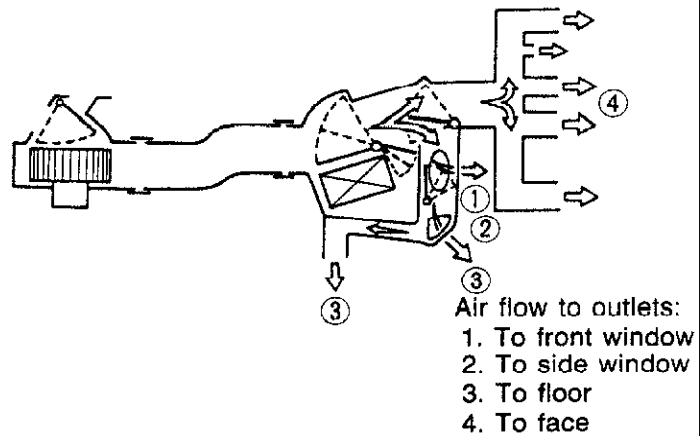
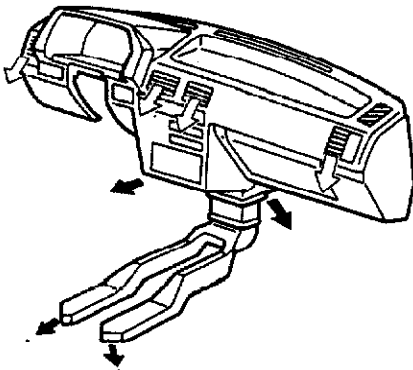
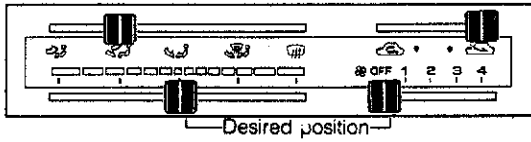

## HEAT

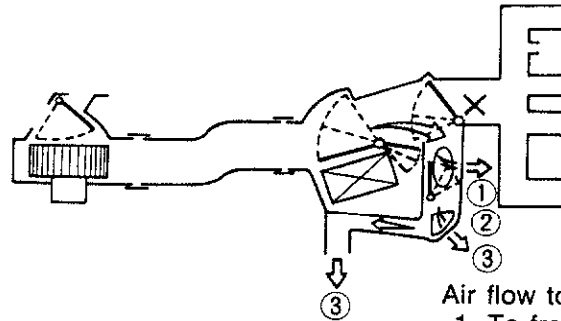
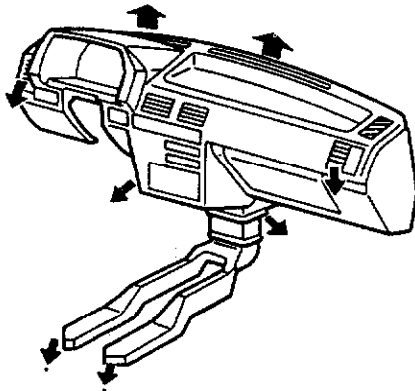
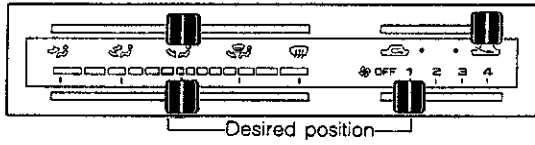

- Air flow to outlets:
1. To front window
  2. To side window
  3. To floor

## HEAT/DEF

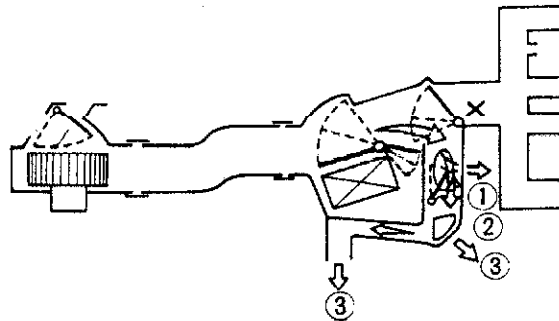
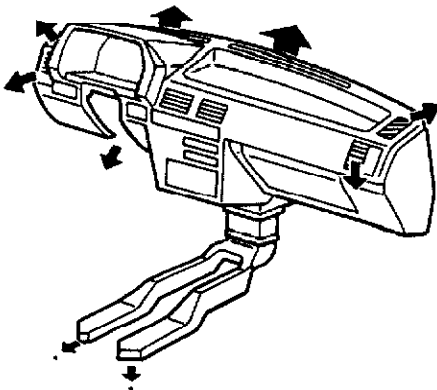
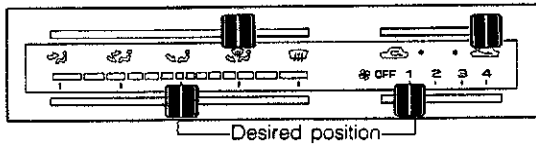

- Air flow to outlets:
1. To front window
  2. To side window
  3. To floor

# 15 HEATER

DEF

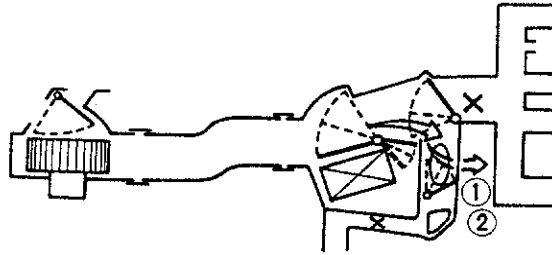
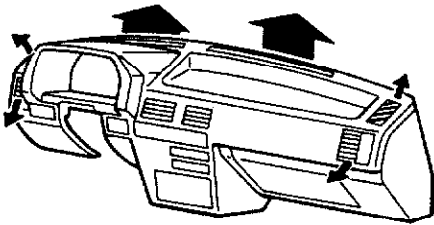
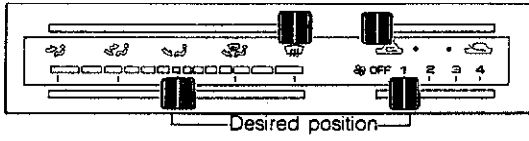

Air flow to outlets:  
1. To front window  
2. To side window

83U15X-119

## HEATER CONTROL SWITCH

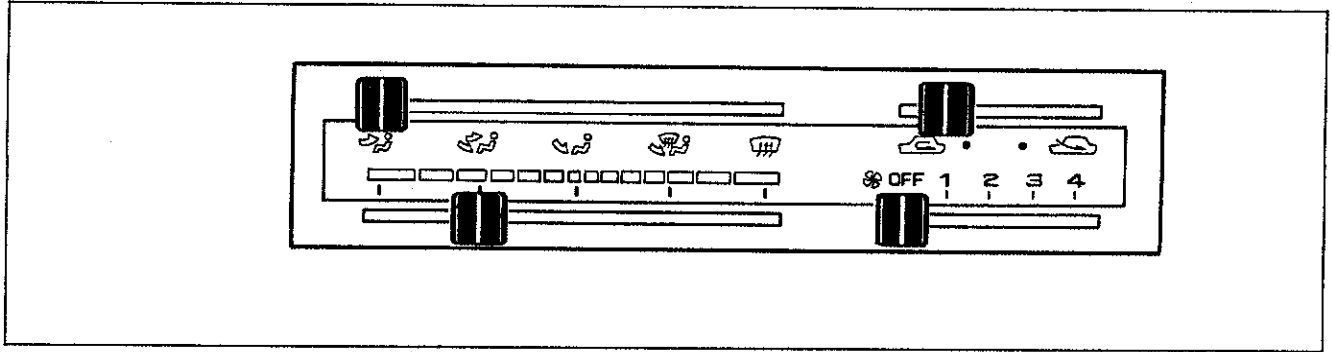

83U15X-120

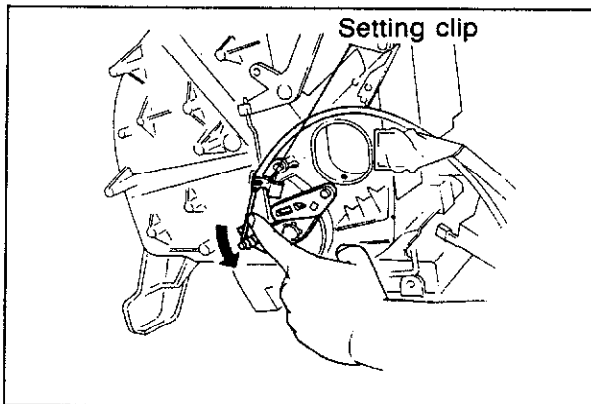

63U15X-206

### ADJUSTMENTS Mode Control Wire

1. Set mode control knob to DEF position.
2. Pull wire lever downward to its extreme stop, then install loop of wire onto lever.

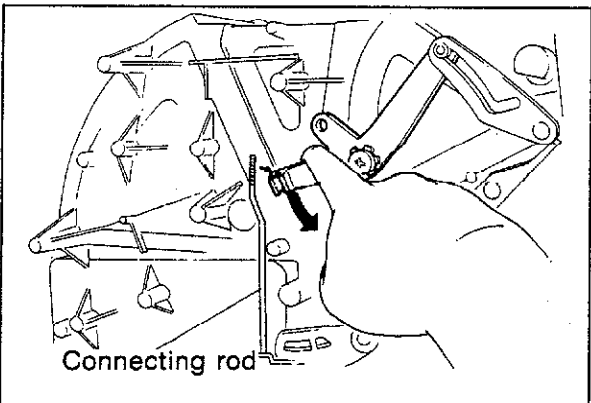

63U15X-207

3. Pull connecting rod downward to its extreme stop, then install connecting rod to fastener.
4. Use clip to clamp rod in position.
5. Set fan speed at "4" to insure proper air circulation.

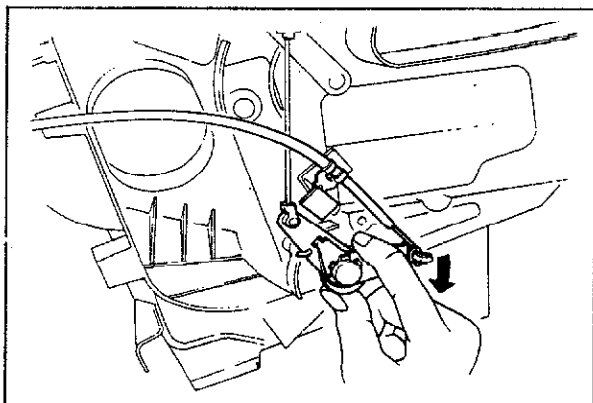

63U15X-208

### Air-Mix Door Control Wire

1. Set TEMP lever at MAX-COLD position.
2. Pull wire lever downward to its extreme stop, then fix Air-Mix wire loop onto lever.

# 15 HEATER

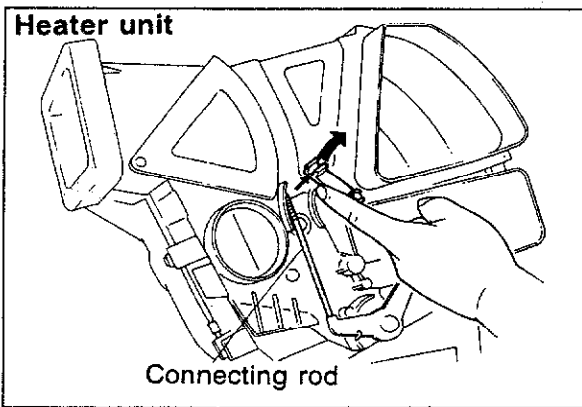

3. Pull connecting rod lever upward to its extreme stop, then install connecting rod to fastener.
4. Use clip to secure rod.
5. Assure proper operation of temperature control.

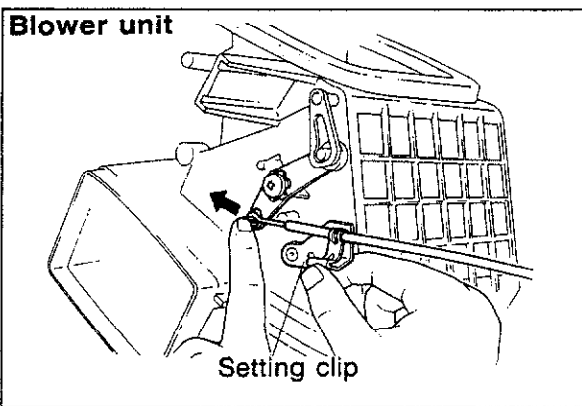

## REC-FRESH Air Selector Wire

1. Set selector lever at fresh air intake position.
2. Push lever forward to its extreme stop, then fix wire loop to lever.
3. Assure proper operation of REC-FRESH Air Selector Control.

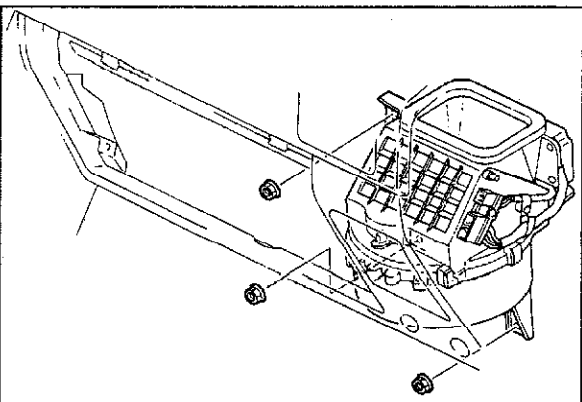

## BLOWER UNIT REMOVAL

Blower unit can be removed as per following procedures without removal of the instrument panel.

1. Remove under cover of instrument panel located in passenger side.
2. Remove glove box.
3. Remove stay of steel plate (black) provided in upper part of glove box.
4. Remove duct in between blower unit and heater unit.

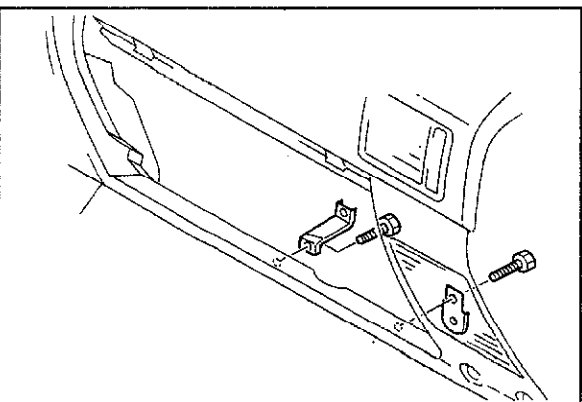

5. Unfasten 3 mounting nuts of blower unit.
6. Remove FRESH-REC air selector wire and harness connector.
7. Remove blower unit.

## Caution

- \* For vehicle models with Air-conditioner, remove instrument panel bracket for ease of blower unit removal.

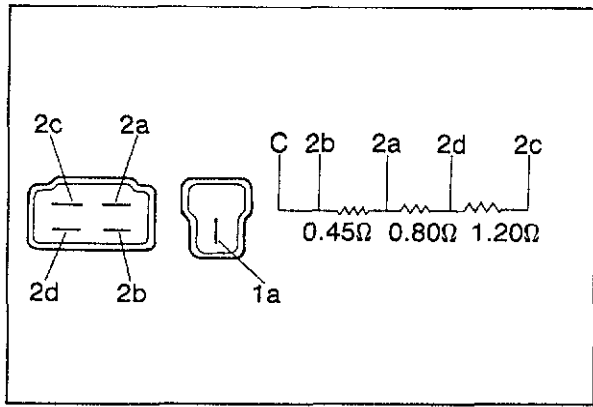

83U15X-144

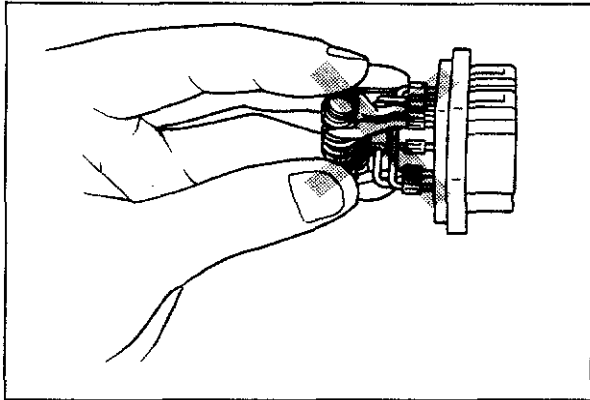

## BLOWER CONTROL RESISTOR

(1) Remove resistor provided underneath the blower unit.

### Note

Resistance level, max. about 4  $\Omega$  of synthetic resistance degree is normal.

If fuse is blown, replace resistor.

Do not touch resistor surface as it may cause faulty fan speed control.



## AUDIO SYSTEM

### OUTLINE OF AUDIO SYSTEM

#### SYSTEM 1

AM/FM MPX ELECTRONIC TUNING RADIO

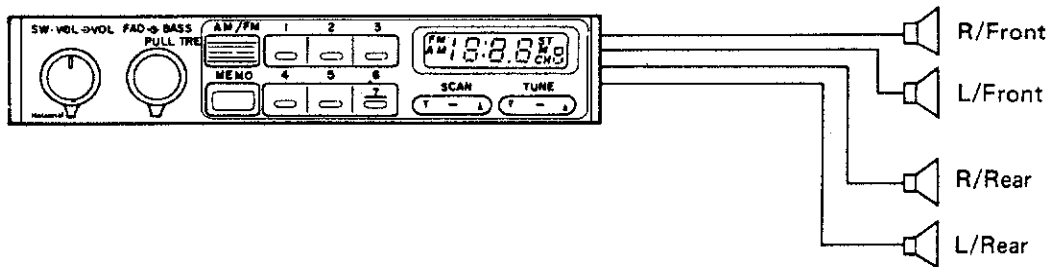

#### SYSTEM 2

AM/FM MPX ELECTRONIC TUNING RADIO  
AUTO REVERSE CASSETTE DECK

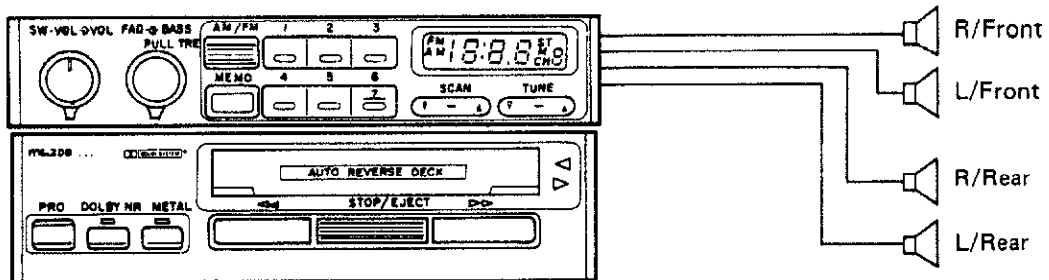

## REAR VIEW AND CONNECTORS

### AM/FM MPX ELECTRONIC TUNING RADIO

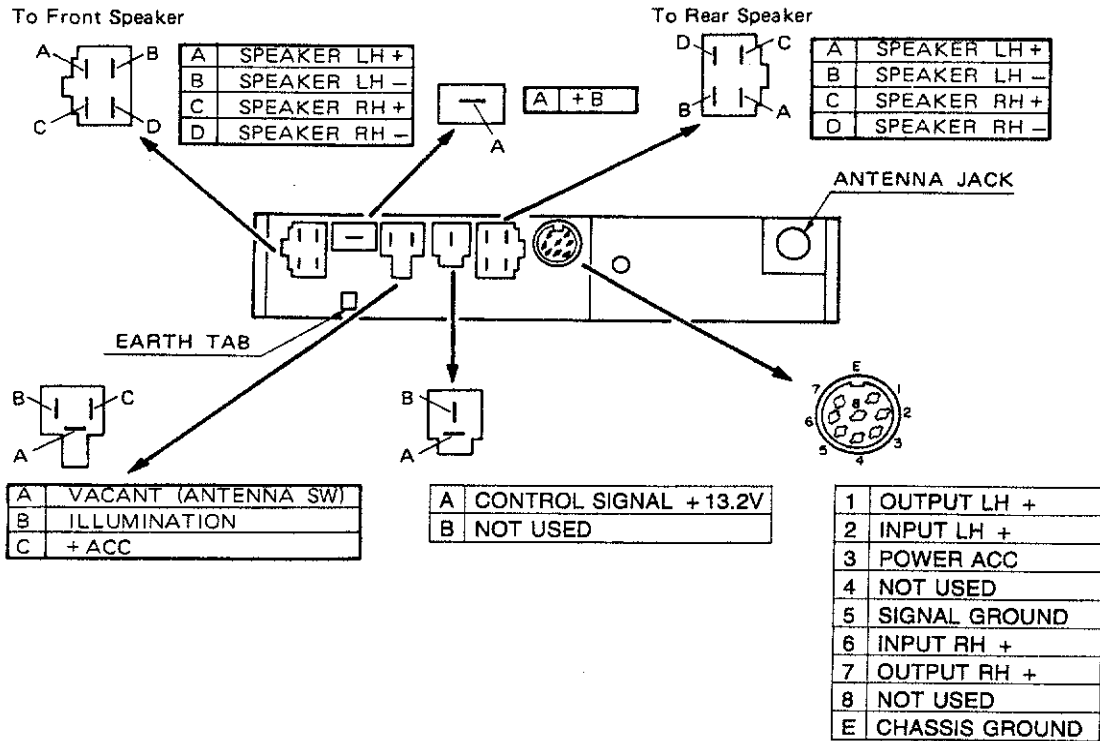

### AUTO REVERSE CASSETTE DECK

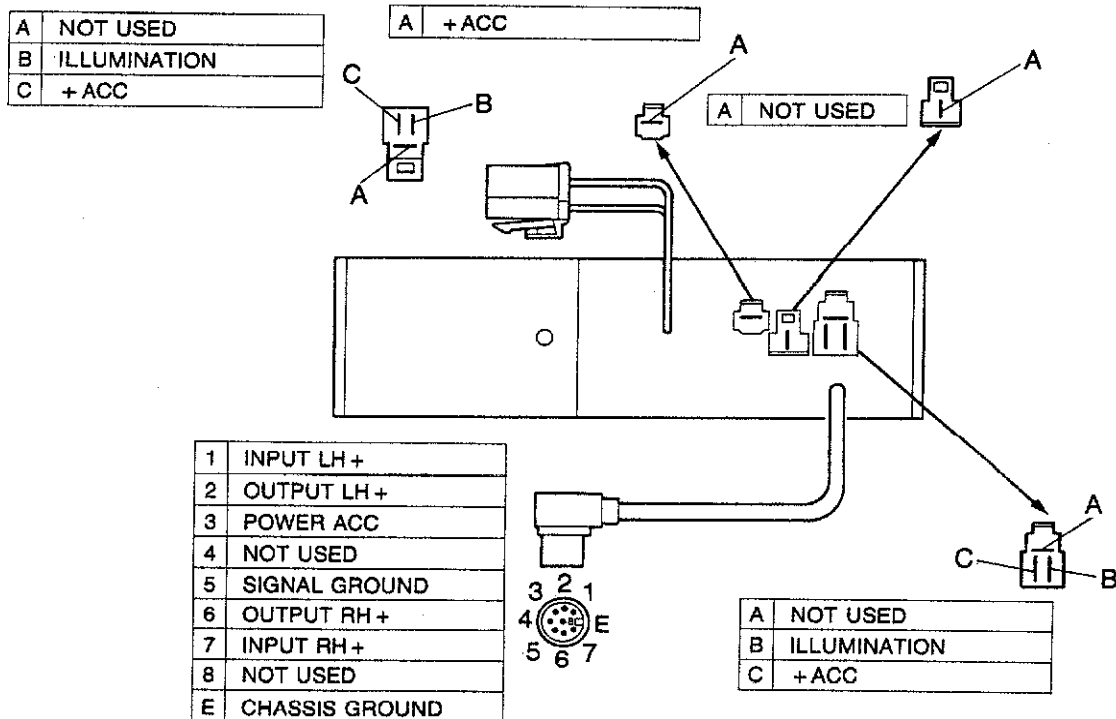

# 15 AUDIO SYSTEM

## TROUBLESHOOTING RADIO

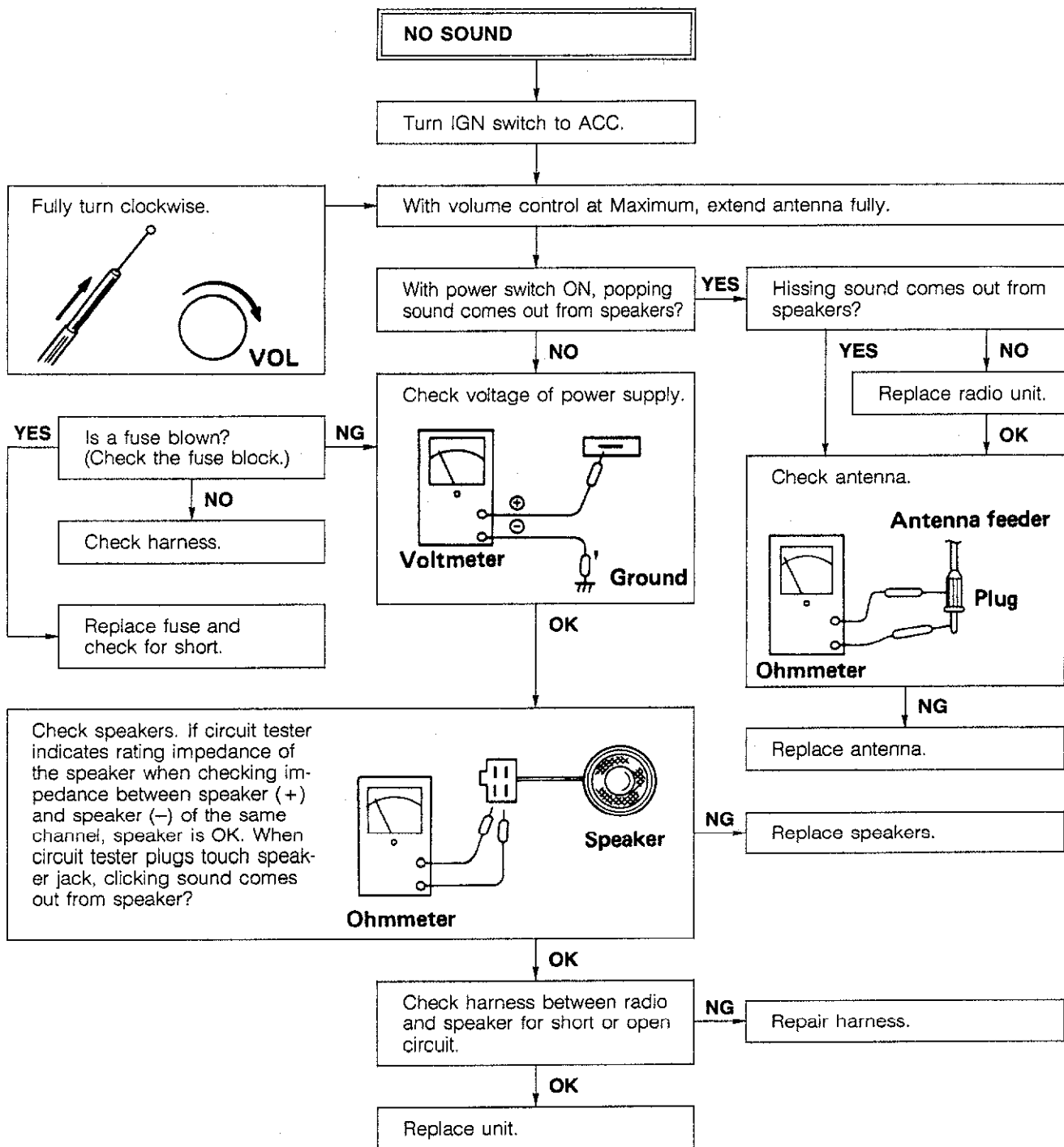

### Caution

- a) When no sound comes out from any of the front, rear, right, left speakers, or volume level is too low, or sound is distorted, set fader and balance control of tuner at center position.

83U15X-147

## TAPE

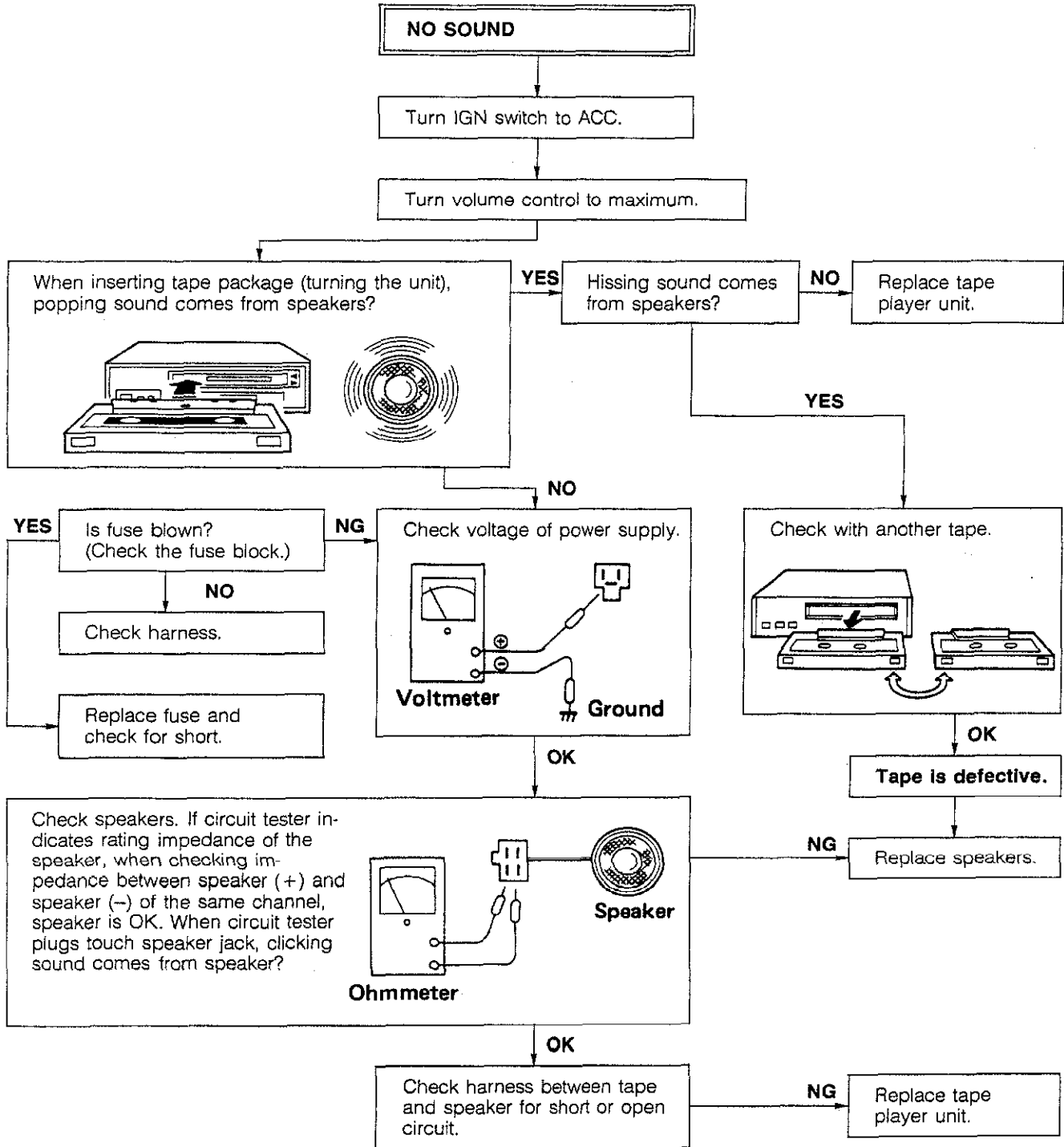

83U15X-148

# 15 AUDIO SYSTEM

## RADIO

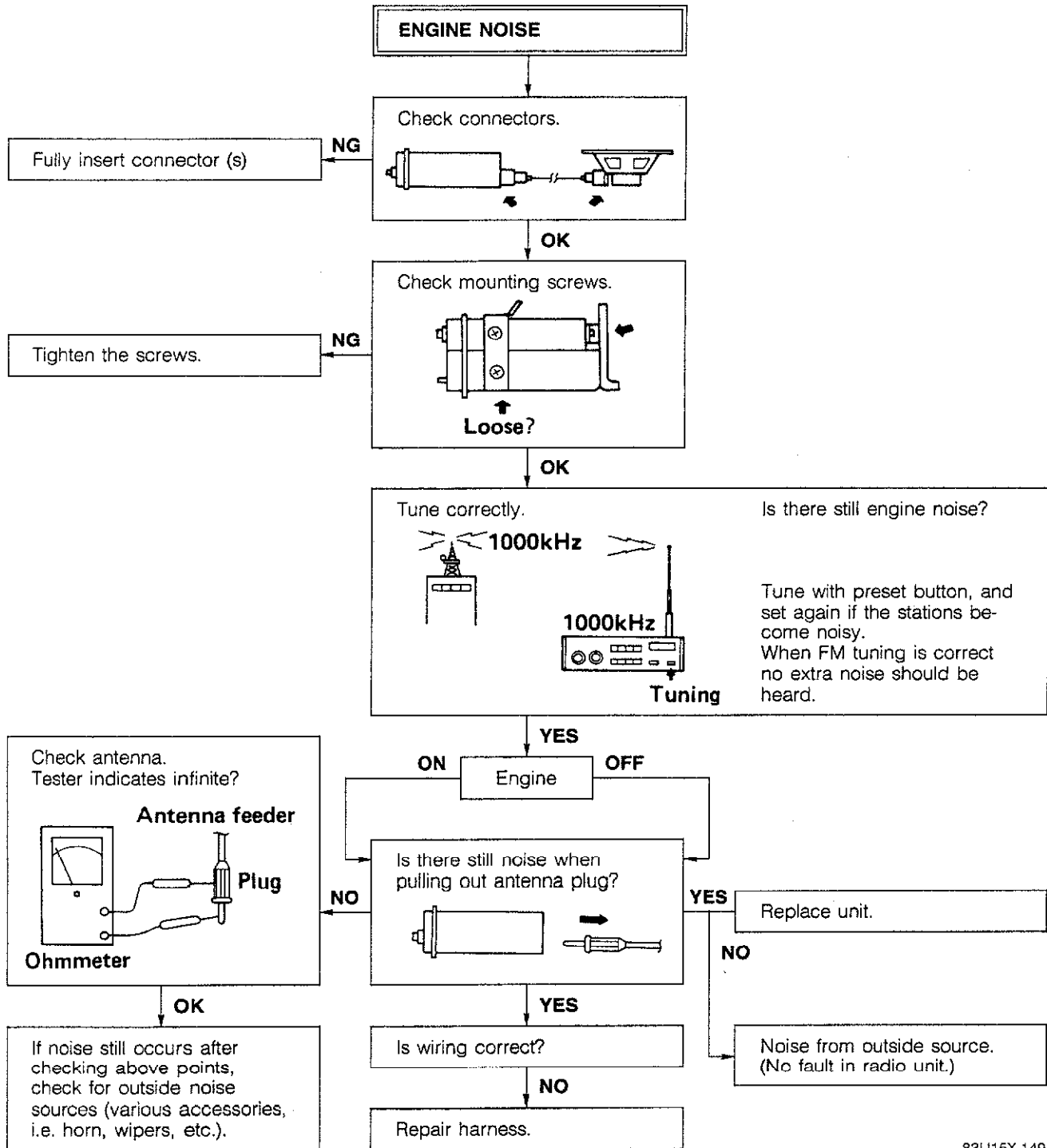

83U15X-149

TAPE

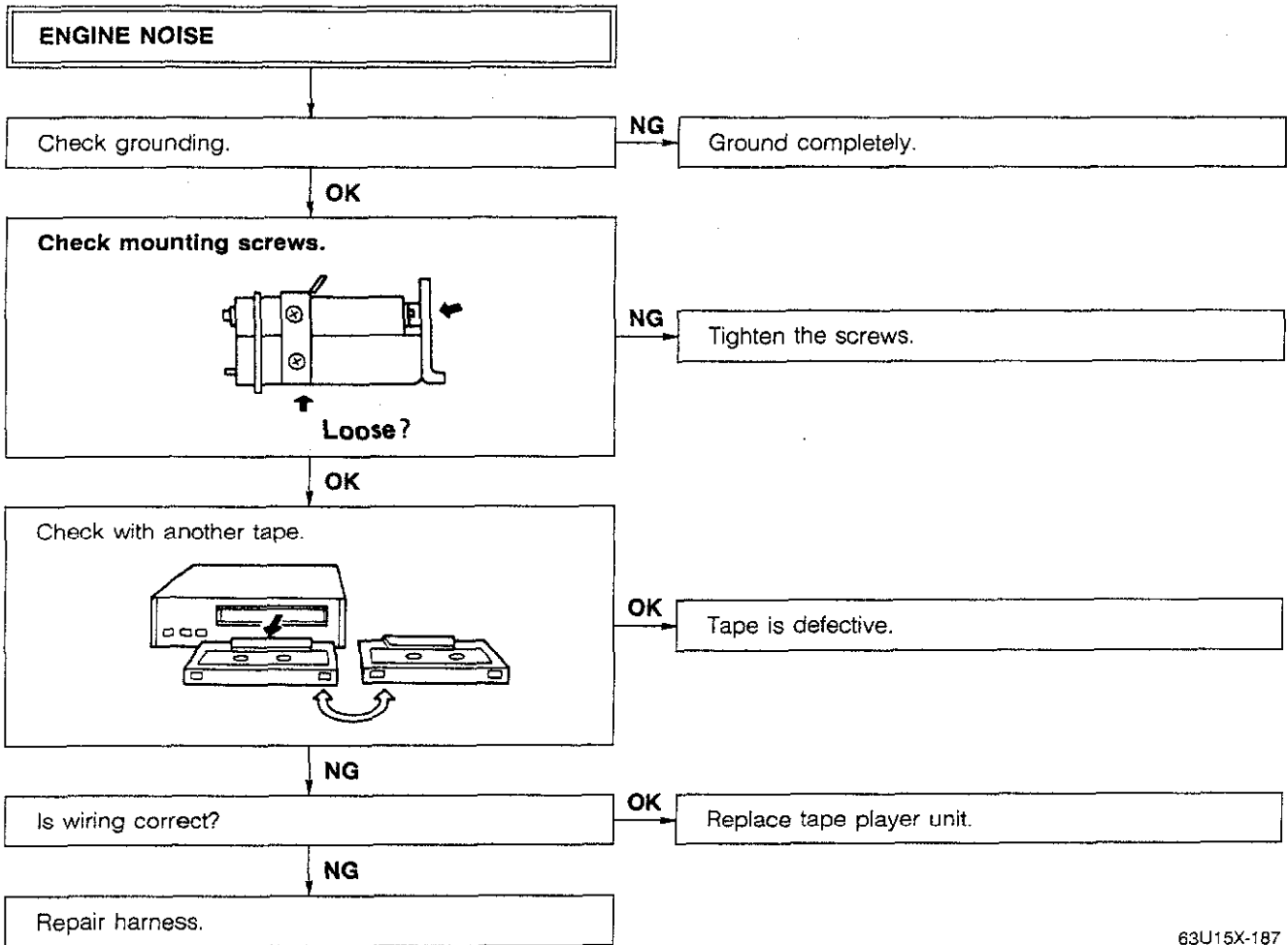

63U15X-187

## RADIO

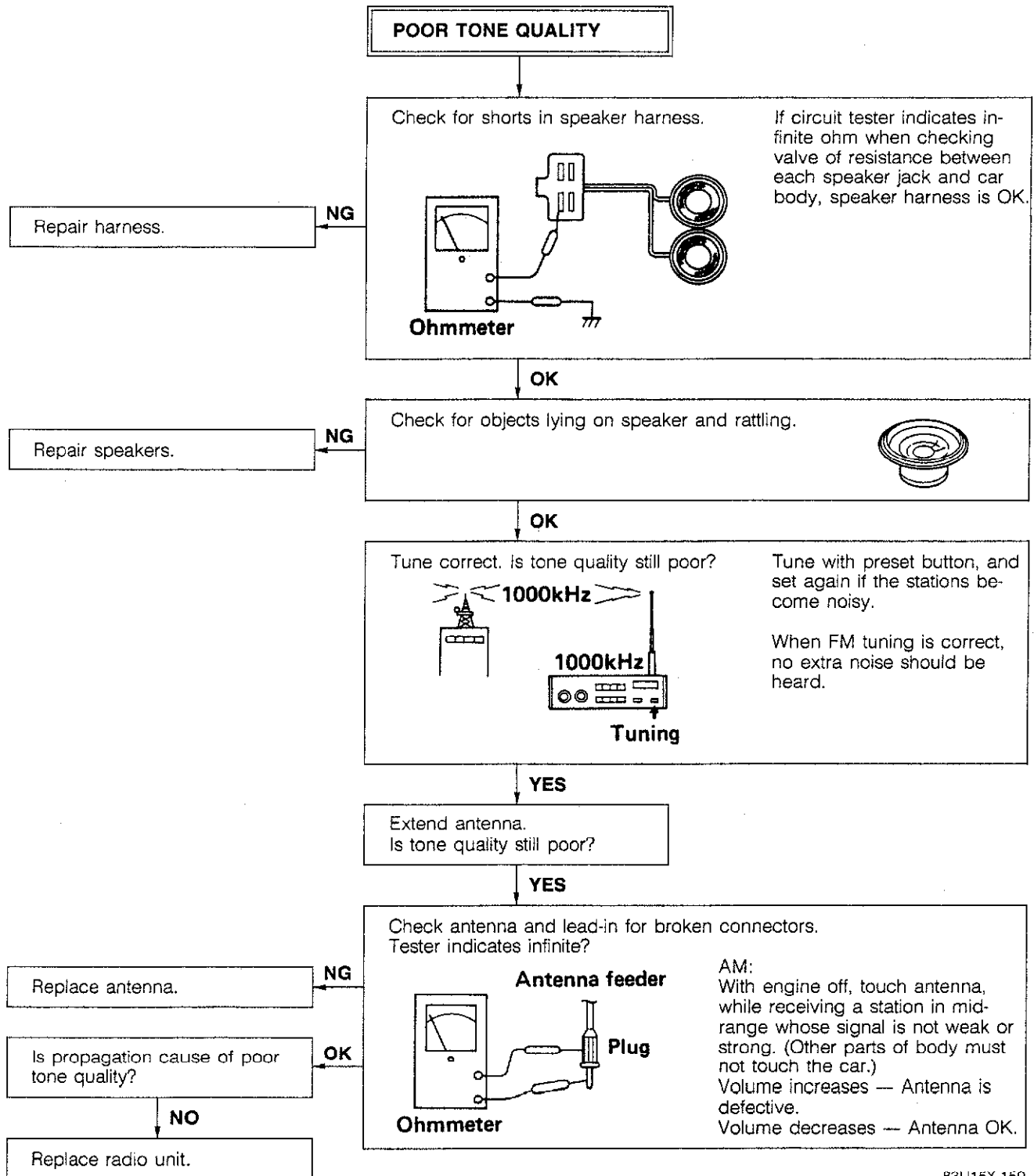

83U15X-150

## TAPE

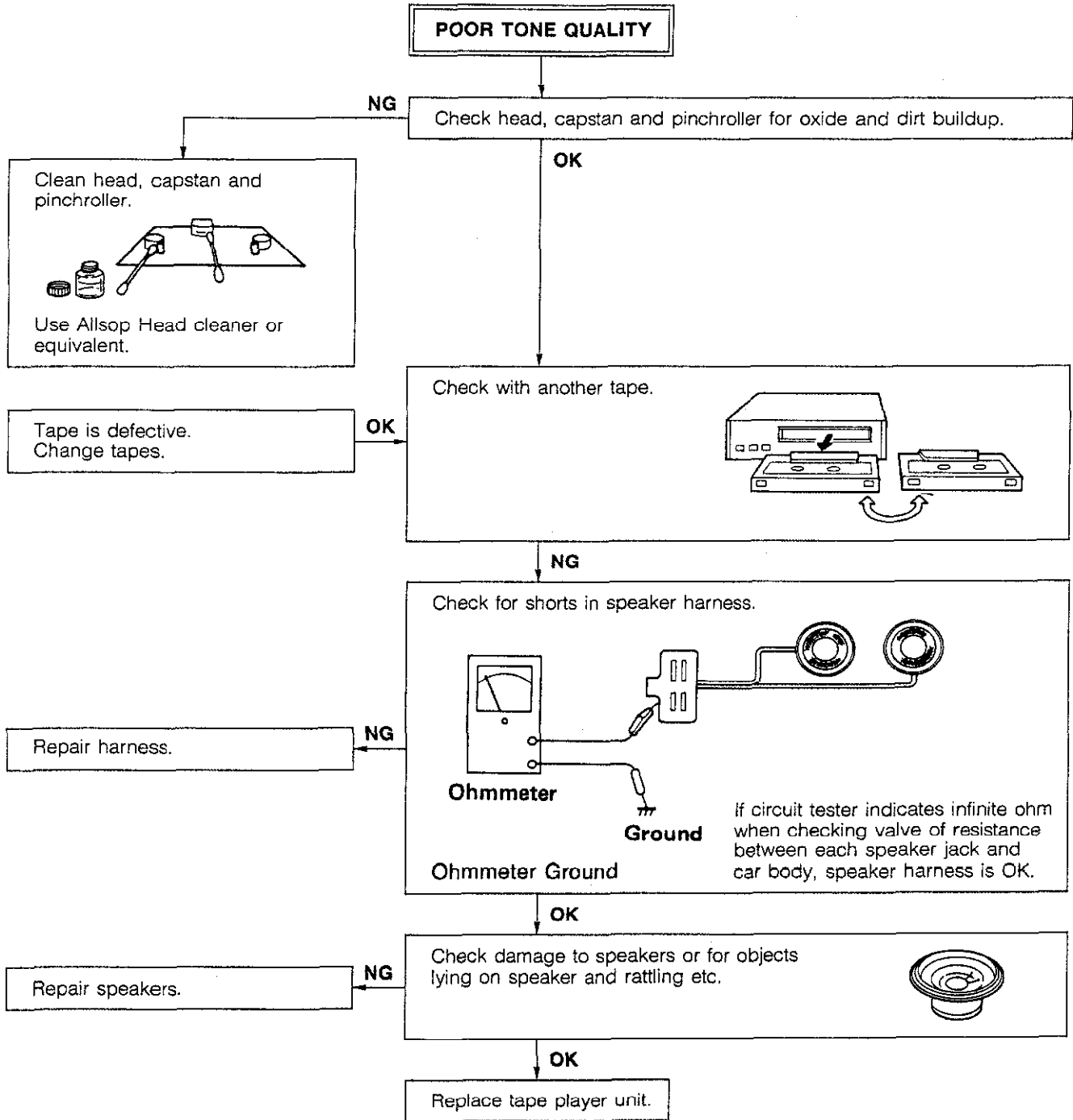

63U15X-189



# 15 AUDIO SYSTEM

## RADIO

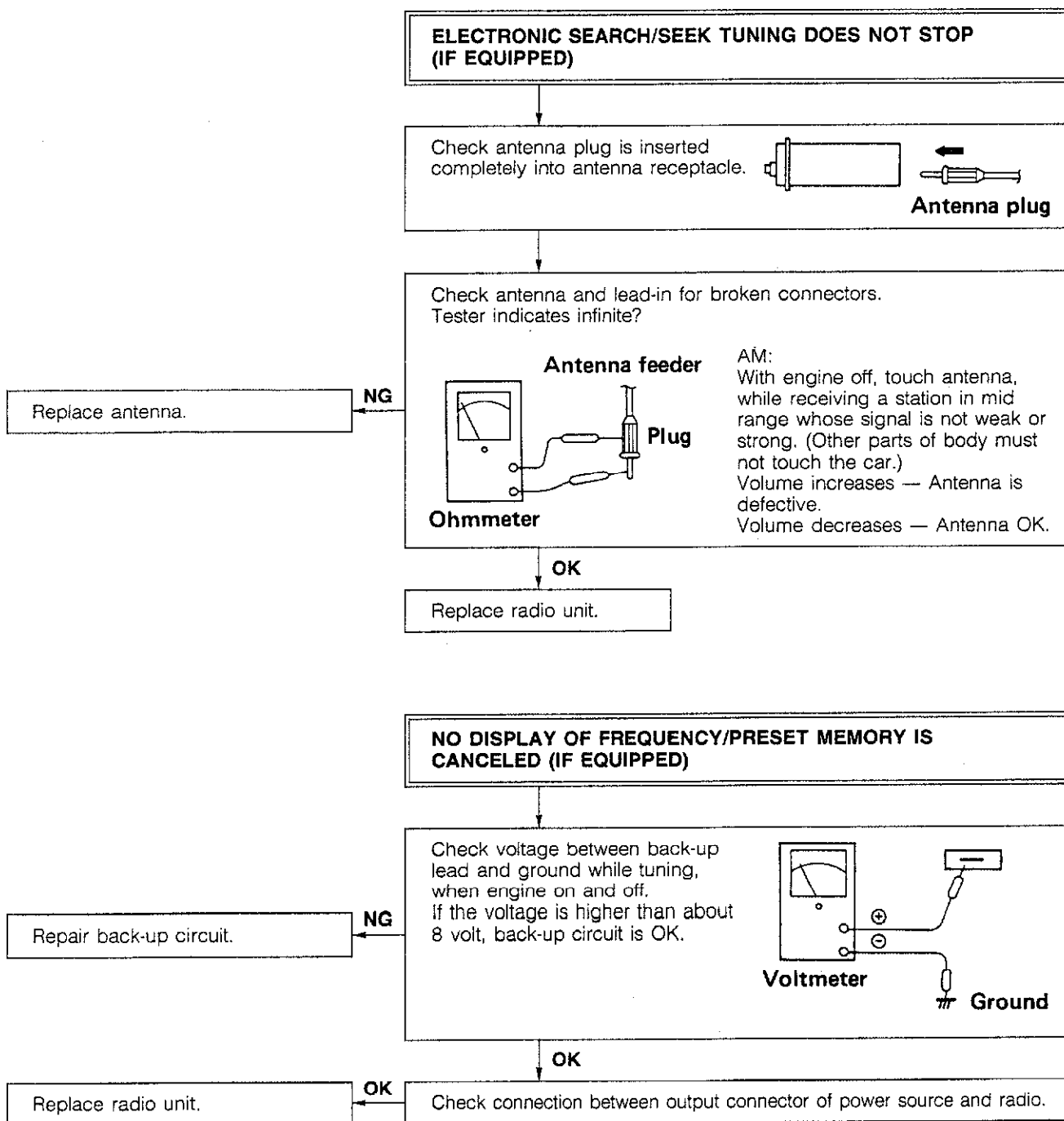

### Note

When battery is discharged or disconnected, or radio is disconnected from battery during repair etc., all memory is cancelled. Preset stations must be reset again.

83U15X-151

## TAPE

**UNIT DAMAGING TAPE OR MARKING TAPE  
(OR "EATING" TAPE)**

Check capstan and pinchroller for oxide and dirt buildup

NG

Clean head, capstan and pinchroller.

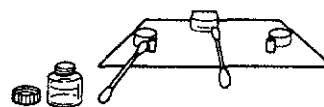

Use Allisop Head-cleaner or equivalent.

OK

Check for tape looseness in cassette.

NG

Tighten tape using a pen or pencil.

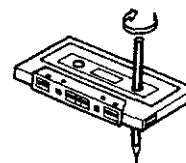

OK

Check that C-120 or longer tape is not used.

USED

Use 30-, 60- or 90-minute tapes.

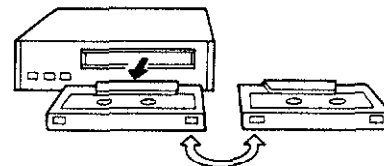

Recommendation: Use only 30-, 60-, or 90-minute cassette tapes, (because 120-minute cassette tape is very thin and delicate.)

OK

Check with another tape.

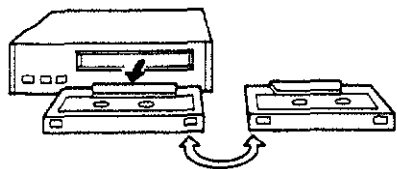

NG

Replace tape unit.

OK

Tape is defective.  
Change tapes.

63U15X-191

## INSTALLATION Radio

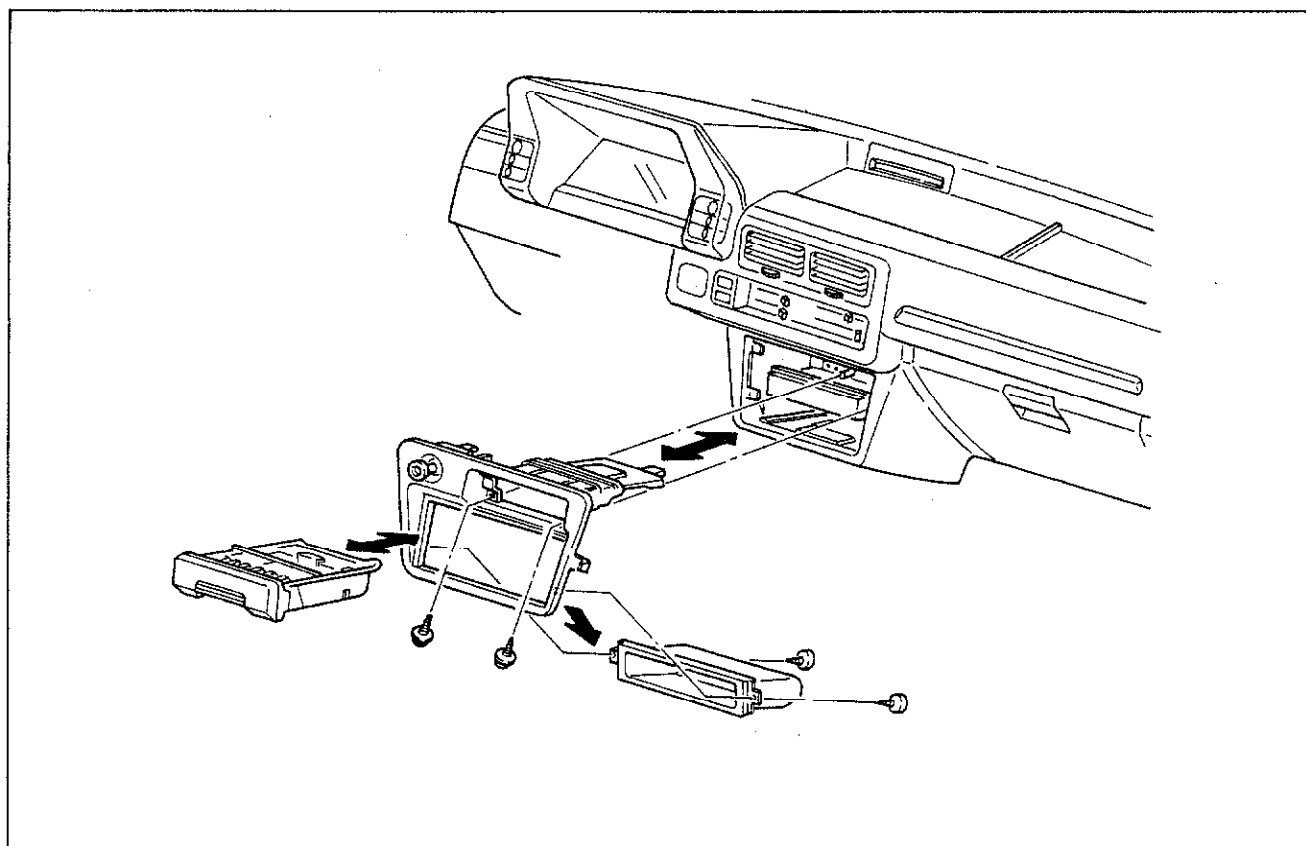

2.

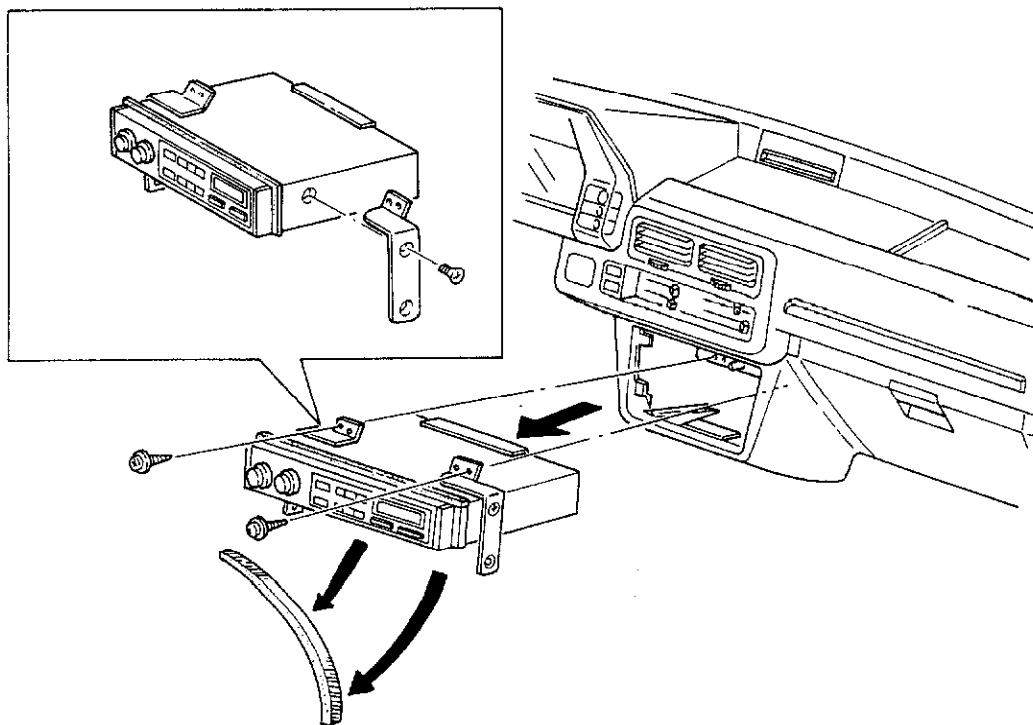

Radio and Cassette Deck

3.

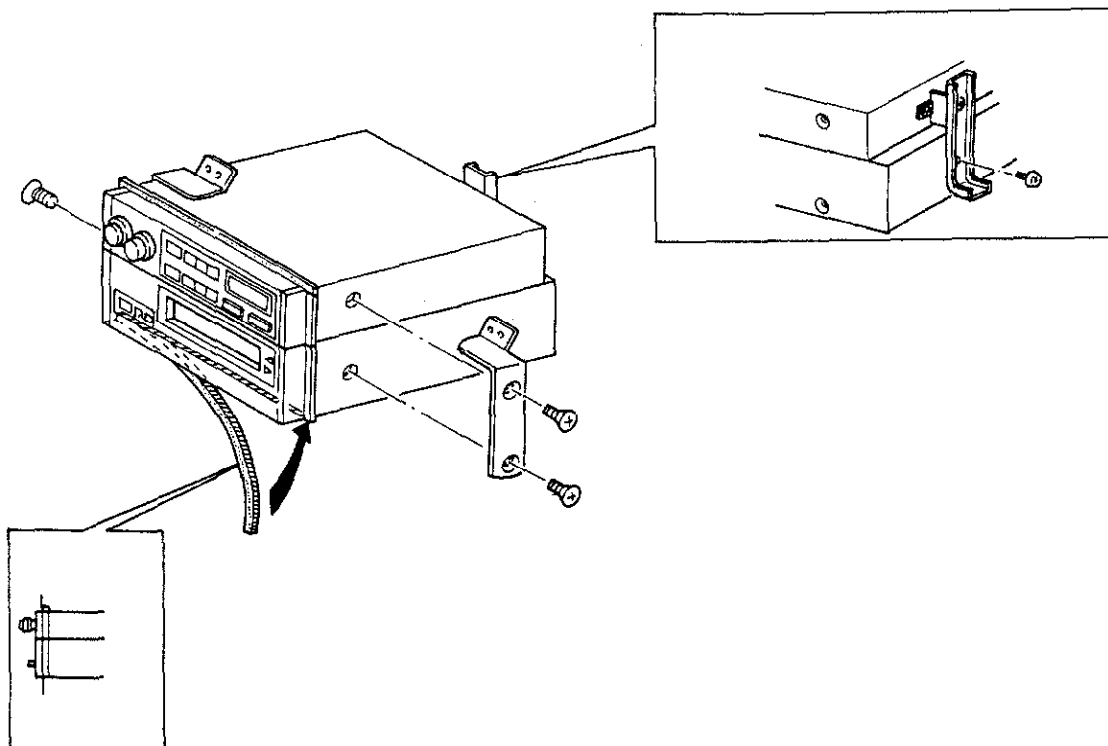

4.

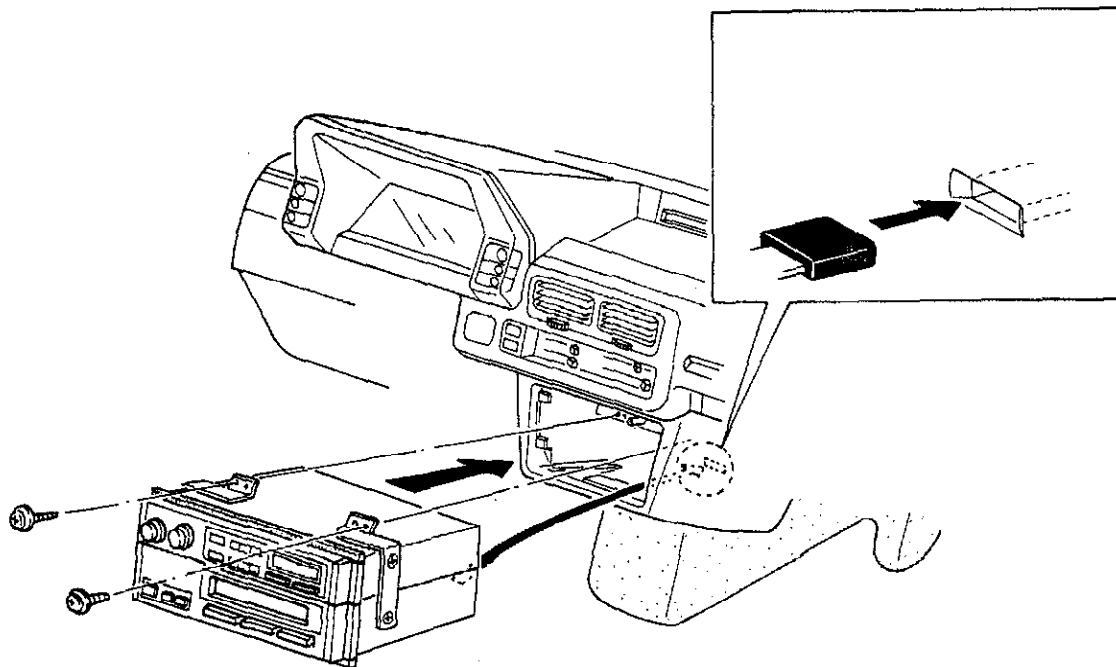

# TECHNICAL DATA

MEASUREMENTS .....	30— 2
ENGINE .....	30— 2
LUBRICATION SYSTEM .....	30— 9
COOLING SYSTEM .....	30—11
FUEL AND EMISSION CONTROL SYSTEM .....	30—12
ENGINE ELECTRICAL SYSTEM.....	30—14
CLUTCH .....	30—16
MANUAL TRANSAXLE .....	30—16
AUTOMATIC TRANSAXLE.....	30—18
MANUAL TRANSAXLE (4WD) .....	30—22
PROPELLER SHAFT .....	30—23
FRONT AND REAR AXLES .....	30—24
STEERING SYSTEM.....	30—24
BRAKING SYSTEM .....	30—25
WHEEL AND TIRE .....	30—27
SUSPENSION .....	30—27
BODY ELECTRICAL SYSTEM .....	30—29
STANDARD BOLT AND NUT TIGHTENING TORQUE .....	30—30

83U30X-001

## 0. MEASUREMENTS

Item	Type	Sedan	Hatchback	
			2WD	4WD
Overall length	mm (in)	4,310 (169.7)	4,110 (161.8)	4,110 (161.8)
Overall width	mm (in)	1,645 (64.8)	1,645 (64.8)	1,645 (64.8)
Overall height	mm (in)	1,390 (54.7)	1,390 (54.7)	1,395 (54.9)
Wheel base	mm (in)	2,400 (94.5)	2,400 (94.5)	2,400 (94.5)
Front tread	mm (in)	1,390 (54.7)	1,390 (54.7)	1,400 (55.1)
Rear tread	mm (in)	1,415 (55.7)	1,415 (55.7)	1,425 (56.1)

## 1A. ENGINE (B6 EGI)

Item		Engine model	B6 EGI
Type			Gasoline, 4-cycle
Number and arrangement of cylinders			4-cylinder, in-line
Type of combustion chamber			Multi-spherical
Valve system			OHC, belt-driven
Bore x Stroke		mm (in)	78 x 83.6 (3.07 x 3.29)
Total piston displacement		cc (cu-in)	1,597 (97.4)
Compression ratio			9.3
Compression pressure kPa (kg/cm <sup>2</sup> , psi)-rpm	Standard		1,324 (13.5, 192)-300
	Minimum		932 (9.5, 135)-300
	Maximum difference between cylinders		196 (2.0, 28)
Valve timing	IN	Open BTDC	14°
		Close ABDC	50°
	EX	Open BBDC	52°
		Close ATDC	12°
Valve clearance (Warm engine)	Valve side	IN	0. Maintenance free
		EX	0. Maintenance free
	Cam side	IN	0. Maintenance free
		EX	0. Maintenance free
<b>Cylinder head</b>			
Height		mm (in)	107.4—107.6 (4.228—4.236)
Distortion		mm (in)	0.15 (0.006) max.
Grinding		mm (in)	0.20 (0.008) max.
<b>Valve and valve guide</b>			
Valve head diameter	mm (in)	IN	37.9—38.1 (1.492—1.500)
		EX	31.9—32.1 (1.256—1.264)
Valve head thickness (margin)	mm (in)	IN	1.0 (0.039)
		EX	1.3 (0.051)
Valve face angle		IN	45°
		EX	45°
Valve length	IN	Standard	103.77 (4.085)
		Minimum	103.3 (4.067)
	EX	Standard	102.67 (4.042)
		Minimum	102.2 (4.024)
Valve stem diameter	mm (in)	IN	6.970—6.985 (0.274—0.275)
		EX	6.965—6.980 (0.274—0.275)
Guide inner diameter		mm (in)	7.01—7.03 (0.2760—0.2768)
Valve stem to guide clearance	mm (in)	IN	0.025—0.060 (0.0010—0.0024)
		EX	0.030—0.065 (0.0011—0.0026)
		Maximum	0.20 (0.0079)
<b>Valve seat</b>			
Seat angle		IN	45°
		EX	45°

Item		Engine model	B6 EGI	
Seat contact width	mm (in)	IN	1.1—1.7 (0.0433—0.0669)	
		EX	1.1—1.7 (0.0433—0.0669)	
Seat sinking	mm (in)	IN	Standard	39.0 (1.535)
			Maximum	40.5 (1.594)
		EX	Standard	39.0 (1.535)
			Maximum	40.5 (1.594)
<b>Valve spring</b>				
Free length of valve spring	mm (in)	Standard	43.7 (1.720)	
		Minimum	42.3 (1.665)	
Out-of-square	mm (in)	Maximum	1.5 (0.059)	
Setting load/height	N (kg, lb)/mm (in)		235 (24.0, 52.8)/35.5 (1.398)	
<b>Camshaft</b>				
Cam height	mm (in)	IN	Standard	36.376—36.526 (1.4321—1.4380)
			Wear limit	36.23 (1.426)
		EX	Standard	36.376—36.526 (1.4321—1.4380)
			Wear limit	36.23 (1.426)
Journal diameter	mm (in)	Front	43.440—43.465 (1.710—1.711)	
		Center	43.410—43.435 (1.709—1.710)	
		Rear	43.440—43.465 (1.710—1.711)	
		Out-of-round	0.05 (0.002) max.	
Camshaft bearing oil clearance	mm (in)	Front	0.035—0.085 (0.001—0.003)	
		Center	0.065—0.115 (0.003—0.005)	
		Rear	0.035—0.085 (0.001—0.003)	
		Maximum	0.15 (0.0059)	
Camshaft runout	mm (in)		0.03 (0.0012) max.	
Camshaft end play	mm (in)	Standard	0.05—0.18 (0.002—0.007)	
		Maximum	0.2 (0.008)	
<b>Rocker arm and rocker arm shaft</b>				
Rocker arm inner diameter	mm (in)		18.000—18.027 (0.7087—0.7097)	
Rocker arm shaft diameter	mm (in)		17.959—17.980 (0.7070—0.7078)	
Rocker arm to shaft clearance	mm (in)	Standard	0.020—0.068 (0.0008—0.0027)	
		Maximum	0.10 (0.0039)	
<b>Cylinder block</b>				
Height	mm (in)		206.5 (8.130)	
Distortion	mm (in)		0.15 (0.006) max.	
Grinding	mm (in)		0.20 (0.008) max.	
Cylinder bore diameter	mm (in)	Standard size	78.000—78.019 (3.0709—3.0717)	
		0.25 (0.010) oversize	78.250—78.269 (3.0807—3.0815)	
		0.50 (0.020) oversize	78.500—78.519 (3.0905—3.0913)	
Cylinder bore taper and out-of-round	mm (in)		0.019 (0.0007) max.	
<b>Piston</b>				
Piston diameter Measured at 90° to pin bore axis and 16.5 mm (0.6496 in) below oil ring groove	mm (in)	Standard size	77.954—77.974 (3.0690—3.0698)	
		0.25 (0.010) oversize	78.204—78.224 (3.0789—3.0797)	
		0.50 (0.020) oversize	78.454—78.474 (3.0887—3.0895)	
Piston and cylinder clearance	mm (in)	Standard	0.026—0.065 (0.0010—0.0026)	
		Maximum	0.15 (0.0059)	

Item		Engine model	B6 EGI	
<b>Piston ring</b>				
Thickness	mm (in)	Top	1.47—1.49 (0.0579—0.0587)	
		Second	1.47—1.49 (0.0579—0.0587)	
End gap Measured in the cylinder	mm (in)	Top	0.20—0.40 (0.0079—0.0157)	
		Second	0.15—0.30 (0.0059—0.0118)	
		Oil (rail)	0.20—0.70 (0.008—0.028)	
		Maximum	1.0 (0.0394)	
Ring groove width in piston	mm (in)	Top	1.520—1.535 (0.0598—0.0604)	
		Second	1.520—1.535 (0.0598—0.0604)	
		Oil	4.020—4.040 (0.1583—0.1591)	
Clearance of piston ring to groove	mm (in)	Top	0.030—0.065 (0.0012—0.0026)	
		Second	0.030—0.065 (0.0012—0.0026)	
		Maximum	0.15 (0.0059)	
<b>Piston pin</b>				
Diameter	mm (in)		19.974—19.980 (0.7864—0.7866)	
Interference in connecting rod	mm (in)		0.013—0.032 (0.0005—0.0013)	
Installing pressure	N (kg, lb)		4,905—14,715 (500—1,500, 1,100—3,300)	
<b>Connecting rod and connecting rod bearing</b>				
Length (Center to center)	mm (in)		132.85—132.95 (5.2303—5.2342)	
Maximum twisting and bending	mm (in)		0.04 (0.002)	
Small end bore	mm (in)		19.948—19.961 (0.7854—0.7859)	
Big end bore	mm (in)		48.000—48.016 (1.8898—1.8904)	
Big end width	mm (in)		21.838—21.890 (0.8598—0.8618)	
Connecting rod side clearance	mm (in)	Standard	0.110—0.262 (0.0043—0.0103)	
		Maximum	0.30 (0.012)	
<b>Crankshaft</b>				
Crankshaft run out	mm (in)		0.04 (0.0016) max.	
Main journal diameter	mm (in)	Standard size	Standard	49.938—49.956 (1.9661—1.9668)
			Minimum	49.89 (1.964)
		0.25 (0.010) undersize	Standard	49.688—49.706 (1.9562—1.9569)
			Minimum	49.64 (1.954)
0.50 (0.020) undersize	Standard	49.438—49.456 (1.9464—1.9471)		
	Minimum	49.39 (1.944)		
Main journal taper and out-of-round	mm (in)		0.05 (0.020) max.	
Crankpin diameter	mm (in)	Standard size	Standard	44.940—44.956 (1.7693—1.7699)
			Minimum	44.89 (1.767)
		0.25 (0.010) undersize	Standard	44.690—44.706 (1.7594—1.7601)
			Minimum	44.64 (1.757)
0.50 (0.020) undersize	Standard	44.440—44.456 (1.7496—1.7502)		
	Minimum	44.39 (1.748)		
Crankpin taper and out-of-round	mm (in)		0.05 (0.020) max.	
<b>Main bearing</b>				
Main journal bearing oil clearance	mm (in)	Standard	0.024—0.042 (0.0009—0.0017)	
		Maximum	0.10 (0.0039)	
Available undersize bearing	mm (in)		0.25 (0.010), 0.50 (0.020)	
<b>Crankpin bearing</b>				
Crankpin bearing oil clearance	mm (in)	Standard	0.028—0.068 (0.0011—0.0027)	
		Maximum	0.10 (0.0039)	
Available undersize bearing	mm (in)		0.25 (0.010), 0.50 (0.020)	
<b>Thrust bearing</b>				
Crankshaft end play	mm (in)	Standard	0.08—0.282 (0.0031—0.0111)	
		Maximum	0.30 (0.0118)	
Bearing width	mm (in)	Standard size	2,500—2,550 (0.0984—0.1004)	
		0.25 (0.010) oversize	2,625—2,675 (0.1033—0.1053)	
		0.50 (0.020) oversize	2,750—2,800 (0.1083—0.1102)	



TIGHTENING TORQUE		N-m	m-kg	ft-lb
Main bearing cap		54—59	5.5—6.0	40—43
Connecting rod cap		47—52	4.8—5.3	35—38
Rear cover assembly		8—11	0.8—1.1	69—95 (in-lb)
End plate		8—11	0.8—1.1	69—95 (in-lb)
Oil pump assembly		19—26	1.9—2.6	14—19
Oil strainer		8—11	0.8—1.1	69—95 (in-lb)
Oil pan		6—9	0.6—0.9	52—78 (in-lb)
Flywheel		96—103	9.8—10.5	71—76
Clutch cover		18—26	1.8—2.7	13—20
Water pump		19—26	1.9—2.6	14—19
Cylinder head bolt		76—81	7.7—8.3	56—60
Cam thrust plate		8—11	0.8—1.1	69—95 (in-lb)
Rocker arm and shaft assembly		22—28	2.2—2.9	16—21
Timing belt pulley		108—128	11.0—13.0	80—94
Camshaft pulley		49—61	5.0—6.2	36—45
Timing belt tensioner		19—26	1.9—2.6	14—19
Timing belt cover		8—11	0.8—1.1	69—95 (in-lb)
Crankshaft pulley		12—17	1.25—1.75	109—152 (in-lb)
Cylinder head cover		5—9	0.5—0.9	43—78 (in-lb)
Oil pressure switch		12—18	1.2—1.8	104—156 (in-lb)
Engine hanger	Front	37—63	3.8—6.4	27—46
	Rear	19—30	1.9—3.1	14—22
Coolant outlet pipe (Thermostat cover)		19—26	1.9—2.6	14—19
Oil level gauge stay		8—11	0.8—1.1	69—95 (in-lb)
Distributor		19—26	1.9—2.6	14—19
Spark plug		15—23	1.5—2.3	11—17
Intake manifold		19—26	1.9—2.6	14—19
Exhaust manifold		16—23	1.6—2.3	12—17
Heat gauge unit		6.4—9.3	0.65—0.95	56—82 (in-lb)
Coolant inlet pipe (Water pump inlet)		19—26	1.9—2.6	14—19
Coolant bypass pipe bracket (Bypass pipe)		16—23	1.6—2.3	12—17
Water pump pulley		8—11	0.8—1.1	69—95 (in-lb)
Alternator strap		37—52	3.8—5.3	27—38
Alternator	Short bolt	19—26	1.9—2.6	14—19
	Long bolt	37—52	3.8—5.3	27—38
Engine mount		37—52	3.8—5.3	27—38
A/C idle pulley		37—52	3.8—5.3	27—38
A/C compressor bracket		37—52	3.8—5.3	27—38
P/S oil pump bracket		47—66	4.8—6.7	35—48
No. 3 engine bracket		93—113	9.5—11.5	69—83
Exhaust pipe		31—46	3.2—4.7	23—34

## 1B. ENGINE (B6 DOHC TURBO)

Item		Engine model	B6 DOHC TURBO
Type			Gasoline, 4-cycle
Number and arrangement of cylinders			4-cylinders, in-line
Type of combustion chamber			Pent-roof
Valve system			DOHC, belt-driven 16 valves
Bore x Stroke		mm (in)	78 x 83.6 (3.07 x 3.29)
Total piston displacement		cc (cu-in)	1,597 (97.4)
Compression ratio			7.9
Compression pressure kPa (kg/cm <sup>2</sup> , psi)-rpm	Standard		1,079 (11.0, 156)-300
	Minimum		755 (7.7, 109)-300
	Maximum difference between		196 (2.0, 28)
Valve timing	IN	Open BTDC	5°
		Close ABDC	51°
	EX	Open BBDC	69°
		Close BTDC	1°
Valve clearance (Warm engine)	Valve side	IN	0. Maintenance free
		EX	0. Maintenance free
	Cam side	IN	0. Maintenance free
		EX	0. Maintenance free
<b>Cylinder head</b>			
Height		mm (in)	133.8—134.0 (5.268—5.276)
Distortion		mm (in)	0.15 (0.006) max.
Grinding		mm (in)	0.20 (0.008) max.
Cylinder head to HLA clearance	mm (in)	Standard	0.025—0.066 (0.0010—0.0026)
		Maximum	0.18 (0.0071)
<b>Valve and valve guide</b>			
Valve head diameter	mm (in)	IN	30.9—31.1 (1.217—1.224)
		EX	26.1—26.3 (1.028—1.035)
Valve head thickness (margin)	mm (in)	IN	0.5 (0.020) min.
		EX	0.5 (0.020) min.
Valve face angle		IN	45°
		EX	45°
Valve length	IN	Standard	105.29 (4.1452)
		Minimum	104.8 (4.126)
	EX	Standard	105.39 (4.1492)
		Minimum	104.9 (4.130)
Valve stem diameter	mm (in)	IN	5.970—5.985 (0.2350—0.2356)
		EX	5.965—5.980 (0.2348—0.2354)
Guide inner diameter		mm (in)	6.01—6.03 (0.2366—0.2374)
Valve stem to guide clearance	mm (in)	IN	0.025—0.060 (0.0010—0.0024)
		EX	0.030—0.065 (0.0012—0.0026)
		Maximum	0.20 (0.0079)
<b>Valve seat</b>			
Seat angle		IN	45°
		EX	45°
Seat contact width	mm (in)	IN	0.8—1.4 (0.0315—0.0551)
		EX	0.8—1.4 (0.0315—0.0551)
Seat sinking	IN	Standard	43.5 (1.713)
		Maximum	45.0 (1.772)
	EX	Standard	43.5 (1.713)
		Maximum	45.0 (1.772)
<b>Valve spring</b>			
Free length of valve spring	mm (in)	Standard	47.2 (1.858)
		Minimum	45.8 (1.803)

Item		Engine model	B6 DOHC TURBO	
Out-of-square		mm (in)	1.6 (0.062) max.	
Setting load/height		N (kg, lb)/mm (in)	196 (20.0, 44.0)/40.0 (1.574)	
<b>Camshaft</b>				
Cam height	mm (in)	IN	Standard	40.888 (1.6098)
			Wear limit	40.688 (1.6019)
	EX	Standard	40.889 (1.6098)	
		Wear limit	40.689 (1.6019)	
Journal diameter	mm (in)	Standard (No. 1—No. 5)	25.940—25.965 (1.0213—1.0222)	
		Out-of-round	0.05 (0.002) max.	
Camshaft bearing oil clearance	mm (in)	Standard (No. 1—No. 5)	0.035—0.081 (0.0014—0.0032)	
		Maximum	0.15 (0.0059)	
Camshaft runout		mm (in)	0.03 (0.0012) max.	
Camshaft end play	mm (in)	Standard	0.07—0.19 (0.0028—0.0075)	
		Maximum	0.2 (0.008)	
<b>Cylinder block</b>				
Height		mm (in)	206.5 (8.130)	
Distortion		mm (in)	0.15 (0.006) max.	
Grinding		mm (in)	0.20 (0.008) max.	
Cylinder bore diameter	mm (in)	Standard size	78.000—78.019 (3.0709—3.0717)	
		0.25 (0.010) oversize	78.250—78.269 (3.0807—3.0815)	
		0.50 (0.020) oversize	78.500—78.519 (3.0905—3.0913)	
Cylinder bore taper and out-of-round		mm (in)	0.019 (0.0007) max.	
<b>Piston</b>				
Piston diameter Measured at 90° to pin bore axis and 16.5 mm (0.6496 in) below oil ring groove	mm (in)	Standard size	77.954—77.974 (3.0690—3.0698)	
		0.25 (0.010) oversize	78.204—78.224 (3.0789—3.0797)	
		0.50 (0.020) oversize	78.454—78.474 (3.0887—3.0895)	
Piston and cylinder clearance	mm (in)	Standard	0.026—0.065 (0.0010—0.0026)	
		Maximum	0.15 (0.0059)	
<b>Piston ring</b>				
Thickness	mm (in)	Top	1.47—1.49 (0.0579—0.0587)	
		Second	1.47—1.49 (0.0579—0.0587)	
End gap Measured in the cylinder	mm (in)	Top	0.20—0.40 (0.0079—0.0157)	
		Second	0.15—0.30 (0.0059—0.0118)	
		Oil (rail)	0.20—0.70 (0.008—0.028)	
		Maximum	1.0 (0.0394)	
Ring groove width in piston	mm (in)	Top	1.520—1.535 (0.0598—0.0604)	
		Second	1.520—1.535 (0.0598—0.0604)	
		Oil	4.020—4.040 (0.1583—0.1591)	
Clearance of piston ring to ring groove	mm (in)	Top	0.030—0.065 (0.0012—0.0026)	
		Second	0.030—0.065 (0.0012—0.0026)	
		Maximum	0.15 (0.0059)	
<b>Piston pin</b>				
Diameter		mm (in)	19.987—19.993 (0.7869—0.7871)	
Interference in piston		mm (in)	0.010—0.027 (0.0004—0.0012)	
<b>Connecting rod and connecting rod bearing</b>				
Length (Center to center)		mm (in)	132.85—132.95 (5.230—5.234)	
Maximum twisting and bending		mm (in)	0.04 (0.002)	
Small end bore		mm (in)	20.003—20.014 (0.7875—0.7880)	
Big end bore		mm (in)	48.000—48.016 (1.8898—1.8904)	
Big end width		mm (in)	21.838—21.890 (0.8598—0.8618)	

Item		Engine model	B6 DOHC TURBO
Connecting rod side clearance	mm (in)	Standard	0.110—0.262 (0.0043—0.0103)
		Maximum	0.30 (0.012)
<b>Crankshaft</b>			
Crankshaft run out		mm (in)	0.04 (0.0016) max.
Main journal diameter	Standard size	Standard	49.938—49.956 (1.9661—1.9668)
		Minimum	49.89 (1.964)
	0.25 (0.010) undersize	Standard	49.688—49.706 (1.9562—1.9569)
		Minimum	49.64 (1.954)
0.50 (0.020) undersize	Standard	49.438—49.456 (1.9464—1.9471)	
	Minimum	49.39 (1.944)	
Main journal taper and out-of-round		mm (in)	0.05 (0.020) max.
Crankpin diameter	Standard size	Standard	44.940—44.956 (1.7693—1.7699)
		Minimum	44.89 (1.767)
	0.25 (0.010) undersize	Standard	44.690—44.706 (1.7594—1.7601)
		Minimum	44.64 (1.757)
	0.50 (0.020) undersize	Standard	44.440—44.456 (1.7496—1.7502)
		Minimum	44.39 (1.748)
Crankpin taper and out-of-round		mm (in)	0.05 (0.020) max.
<b>Main bearing</b>			
Main journal bearing oil clearance	mm (in)	Standard	0.024—0.042 (0.0010—0.0017)
		Maximum	0.08 (0.0031)
Available undersize bearing		mm (in)	0.25 (0.010), 0.50 (0.020)
<b>Crankpin bearing</b>			
Crankpin bearing oil clearance	mm (in)	Standard	0.028—0.068 (0.0011—0.0027)
		Maximum	0.10 (0.0039)
Available undersize bearing		mm (in)	0.25 (0.010), 0.50 (0.020)
<b>Thrust bearing</b>			
Crankshaft end play	mm (in)	Standard	0.080—0.282 (0.0031—0.011)
		Maximum	0.30 (0.0118)
Bearing width	Standard size	mm (in)	2,500—2,550 (0.0984—0.1004)
	0.25 (0.010) oversize	mm (in)	2,625—2,675 (0.1033—0.1053)
	0.50 (0.020) oversize	mm (in)	2,750—2,800 (0.1083—0.1102)

TIGHTENING TORQUE	N-m	m-kg	ft-lb
Oil jet	12—18	1.2—1.8	104—156 (in-lb)
Main bearing cap	54—59	5.5—6.0	40—43
Connecting rod cap	65—69	6.6—7.0	48—51
Rear cover assembly	8—11	0.8—1.1	69—95 (in-lb)
End plate	8—11	0.8—1.1	69—95 (in-lb)
Oil pump assembly	19—26	1.9—2.6	14—19
Oil strainer	8—11	0.8—1.1	69—95 (in-lb)
Oil pan	8—11	0.8—1.1	69—95 (in-lb)
Fly wheel	96—103	9.8—10.5	71—76
Clutch cover	18—26	1.8—2.7	13—20
Water pump	19—26	1.9—2.6	14—19
Cylinder head bolt	76—81	7.7—8.3	56—60
Camshaft cap	11—14	1.15—1.45	100—126 (in-lb)
Engine bracket and mount arm	93—113	9.5—11.5	69—83
Cylinder head cover	3—4	0.3—0.4	26—35 (in-lb)
Timing belt pulley	108—128	11.0—13.0	80—94
Seal plate	8—11	0.8—1.1	69—95 (in-lb)
Camshaft pulley	49—61	5.0—6.2	36—45
Timing belt tensioner and idler pulley	37—52	3.8—5.3	27—38

TIGHTENING TORQUE		N-m	m-kg	ft-lb
Timing belt cover		8—11	0.8—1.1	69—95 (in-lb)
Crankshaft pulley		12—17	1.25—1.75	109—152 (in-lb)
Oil pressure switch		12—18	1.2—1.8	104—156 (in-lb)
Oil cooler		29—39	3.0—4.0	22—29
Knock sensor		20—34	2.0—3.5	14—25
Engine hanger	Front	37—52	3.8—5.3	27—38
	Rear	37—52	3.8—5.3	27—38
Coolant outlet pipe (Thermostat cover)		19—26	1.9—2.6	14—19
Oil level gauge stay		8—11	0.8—1.1	69—95 (in-lb)
Distributor		19—26	1.9—2.6	14—19
Spark plug		15—23	1.5—2.3	11—17
Intake manifold		19—26	1.9—2.6	14—19
Exhaust manifold		39—57	4.0—5.8	29—42
Turbocharger		27—33	2.8—3.4	20—25
Turbocharger bracket		43—61	4.4—6.2	32—45
Exhaust manifold insulator		19—26	1.9—2.6	14—19
Heat gauge unit		6.4—9.3	0.65—0.95	56—82 (in-lb)
Coolant inlet pipe (Water pump inlet)		19—26	1.9—2.6	14—19
Coolant bypass pipe bracket (Bypass pipe)		39—57	4.0—5.8	29—42
Water pump pulley		8—11	0.8—1.1	69—95 (in-lb)
Alternator strap		37—52	3.8—5.3	27—38
Alternator	Short bolt	19—26	1.9—2.6	14—19
	Long bolt	37—52	3.8—5.3	27—38
Air intake pipe		8—11	0.8—1.1	69—95 (in-lb)
Engine mount		37—52	3.8—5.3	27—38
A/C idle pulley		37—52	3.8—5.3	27—38
A/C compressor bracket		37—52	3.8—5.3	27—38
P/S oil pump bracket		47—66	4.8—6.7	35—48
Exhaust pipe		31—46	3.2—4.7	23—34

## 2A. LUBRICATION SYSTEM (B6 EGI)

Engine model		B6 EGI
<b>Item</b>		
Lubricating method		Force-fed type
<b>Oil pump</b>		
Type		Trochoid gear
Regulating pressure at 3,000 rpm of engine kPa (kg/cm <sup>2</sup> , psi)		343—441 (3.5—4.5, 50—64)
Inner rotor tooth tip and outer rotor clearance	Standard	0.02—0.16 (0.0008—0.0063)
	Maximum	0.2 (0.0078)
Outer rotor and body clearance	Standard	0.09—0.18 (0.0035—0.0071)
	Maximum	0.22 (0.0087)
Side clearance	Standard	0.03—0.11 (0.0012—0.0043)
	Maximum	0.14 (0.0055)
<b>Oil filter</b>		
Type		Full flow paper element
Relief pressure differential kPa (kg/cm <sup>2</sup> , psi)		98 (1.0, 14)
<b>Oil pressure switch</b>		
Activation pressure kPa (kg/cm <sup>2</sup> , psi)		29 (0.3, 4.3)
<b>Engine oil</b>		
Capacity	Total (dry engine)	3.4 (3.6, 3.0)
	Oil pan	3.0 (3.2, 2.6)
	Oil filter	0.3 (0.32, 0.26)
Grade		API Service SD, SE, or SF

Item	Engine model	B6 EGI
Classification	30°C (85°F) or over	SAE 40
	0°C—40°C (32°F—100°F)	SAE 30
	-10°C—20°C (15°F—68°F)	SAE 20W-20
	-10°C—50°C (15°F—120°F) or over	SAE 20W-40 or 20W-50
	-25°C—30°C (-18°F—86°F)	SAE 10W-30
	-25°C—50°C (-18°F—120°F) or over	SAE 10W-40 or 10W-50
	0°C—30°C (32°F—22°F) or below	SAE 5W-30
	-20°C (4°F) or below	SAE 5W-20

TIGHTENING TORQUE	N-m	m-kg	ft-lb
Oil filter		By hand	
Oil pan	6—9	0.6—0.9	52—78 (in-lb)
Oil pump	19—26	1.9—2.6	14—19
Oil pressure switch	12—18	1.2—1.8	104—156 (in-lb)
Oil strainer	8—11	0.8—1.1	69—95 (in-lb)
Oil drain plug	29—41	3.0—4.2	22—30

## 2B. LUBRICATION SYSTEM (B6 DOHC TURBO)

Item	Engine model	B6 DOHC TURBO	
Lubricating method		Force-fed type	
<b>Oil pump</b>			
Type		Trochoid gear	
Regulating pressure at 3,000 rpm of engine	kPa (kg/cm <sup>2</sup> , psi)	343—441 (3.5—4.5, 50—64)	
Inner rotor tooth tip and outer rotor clearance	Standard	0.02—0.16 (0.0008—0.0063)	
	mm (in)	Maximum	0.2 (0.0078)
Outer rotor and body clearance	Standard	0.09—0.18 (0.0035—0.0071)	
	mm (in)	Maximum	0.22 (0.0087)
Side clearance	Standard	0.03—0.11 (0.0012—0.0043)	
	mm (in)	Maximum	0.14 (0.0055)
<b>Oil filter</b>			
Type		Full flow paper element	
Relief pressure differential	kPa (kg/cm <sup>2</sup> , psi)	98 (1.0, 14)	
<b>Oil pressure switch</b>			
Activation pressure	kPa (kg/cm <sup>2</sup> , psi)	29 (0.3, 4.3)	
<b>Engine oil</b>			
Capacity	Liters (US qt, Imp qt)	Total (dry engine)	3.6 (3.8, 3.2)
		Oil pan	3.2 (3.4, 2.8)
		Oil filter	0.3 (0.32, 0.26)
Grade		API Service SF	
Classification	30°F (85°F) or over	SAE 40	
	0°C—40°C (32°F—100°F)	SAE 30	
	-10°C—20°C (15°F—68°F)	SAE 20W-20	
	-10°C—50°C (15°F—120°F) or over	SAE 20W-40 or 20W-50	
	-25°C—30°C (-18°F—86°F)	SAE 10W-30	
	-25°C—50°C (-18°F—120°F) or over	SAE 10W-40 or 10W-50	
	0°C—30°C (32°F—22°F) or below	SAE 5W-30	
	-20°C (4°F) or below	SAE 5W-20	

TIGHTENING TORQUE	N-m	m-kg	ft-lb
Oil filter	By hand		
Oil pan	8—11	0.8—1.1	69—95 (in-lb)
Oil pump assembly	19—26	1.9—2.6	14—19
Oil pressure switch	12—18	1.2—1.8	104—156 (in-lb)
Oil strainer	8—11	0.8—1.1	69—95 (in-lb)
Oil drain plug	29—41	3.0—4.2	22—30
Oil cooler	29—39	3.0—4.0	22—29

### 3A. COOLING SYSTEM (B6 EGI)

Item		Engine model	B6 EGI			
Cooling method			Water-cooled, forced circulation			
<b>Water pump</b>						
Type			Centrifugal, V belt driven			
Impeller diameter		mm (in)	72 (2.83)			
Number of impeller			6			
Speed ratio			1 : 1.05			
Water seal type			Unified mechanical seal			
<b>Thermostat</b>						
Start to open		°C (°F)	SUB: 85 (185), MAIN: 88 (190)			
Full-open		°C (°F)	100 (212)			
Lift		mm (in)	SUB: 1.5 (0.06) or more, MAIN: 8.0 (0.31) or more			
<b>Radiator</b>						
Type			Corrugated fin			
Cap opening valve pressure		kPa (kg/cm <sup>2</sup> , psi)	74—103 (0.73—1.05, 11—15)			
Cooling circuit checking pressure		kPa (kg/cm <sup>2</sup> , psi)	103 (1.05, 15)			
<b>Electric fan</b>						
Type			Electric type			
Number of blades			4			
Outer diameter		mm (in)	MTX: 300 (11.81)	ATX: 320 (12.60)		
Switching temperature OFF → ON		°C (°F)	91 (196)			
Capacity		W-V	MTX: 80-12	ATX: 120-12		
Standard current		A	MTX: 5.6—7.6	ATX: 10.0—11.0		
<b>Coolant</b>						
Capacity		liters (US qt, Imp qt)	MTX 5.0 (5.3, 4.4)	ATX 6.0 (6.3, 5.3)		
Antifreeze solution	Protection	Mixture percentage (volume) %		Specific gravity of mixture at 20°C (68°F)		
		Water	Solution			
		Above -16°C (3°F)	65		35	1.054
		Above -26°C (-15°F)	55		45	1.066
Above -40°C (-40°F)	45	55	1.078			

TIGHTENING TORQUE	N-m	m-kg	ft-lb
Temperature gauge sensor (meter)	6—9	0.65—0.95	56—82 (in-lb)
Thermostat cover (Coolant outlet pipe)	19—26	1.9—2.6	14—19
Water pump	19—26	1.9—2.6	14—19
Water thermo switch	6—9	0.6—0.9	52—78 (in-lb)

## 3B. COOLING SYSTEM (B6 DOHC TURBO)

Engine model		B6 DOHC TURBO				
Item						
Cooling method		Water-cooled, forced circulation				
<b>Water pump</b>						
Type		Centrifugal, V belt driven				
Impeller diameter	mm (in)	75 (2.95)				
Number of impeller		6				
Speed ratio		1 : 1.05				
Water seal type		Unified mechanical seal				
<b>Thermostat</b>						
Start to open	°C (°F)	SUB: 85 (185), MAIN: 88 (190)				
Full-open	°C (°F)	100 (212)				
Lift	mm (in)	SUB: 1.5 (0.06) or more, MAIN: 8.0 (0.31) or more				
<b>Radiator</b>						
Type		Corrugated fin				
Cap opening valve pressure	kPa (kg/cm <sup>2</sup> , psi)	74—103 (0.75—1.05, 11—15)				
Cooling circuit checking pressure	kPa (kg/cm <sup>2</sup> , psi)	103 (1.05, 15)				
<b>Electric fan</b>						
Type		Electric type				
Number of blades		4				
Outer diameter	mm (in)	320 (12.6)				
Switching temperature OFF → ON	°C (°F)	97 (207)				
Capacity	W-V	4WD: Hi 160-12, Low 106-12, 2WD: 120-12				
Standard current	A	4WD: Hi 13.3—14.6, Low 8.8—9.7, 2WD: 10.0—11.0				
<b>Coolant</b>						
Capacity	liters (US qt, Imp qt)	6.0 (6.3, 5.3)				
Antifreeze solution	Protection	Mixture percentage (volume) %		Specific gravity of mixture at 20°C (68°F)		
		Water	Solution			
		Above -16°C (3°F)	65		35	1.054
		Above -26°C (-15°F)	55		45	1.066
Above -40°C (-40°F)	45	55	1.078			

TIGHTENING TORQUE	N·m	m·kg	ft·lb
Temperature gauge sensor (meter)	6—9	0.65—0.95	56—82 (in·lb)
Thermostat cover (Coolant outlet pipe)	19—26	1.9—2.6	14—19
Water pump	19—26	1.9—2.6	14—19
Water thermo switch	6—9	0.6—0.9	52—78 (in·lb)

## 4A. FUEL AND EMISSION CONTROL SYSTEM (B6 EGI)

Transaxle type		Manual Transaxle	Automatic Transaxle
Item			
Idle speed	rpm	850 ± 50 in Neutral	850 ± 50 in P range
<b>Throttle body</b>			
Type		Horizontal draft (1-barrel)	
Throttle diameter	mm (in)	50 (1.9)	
<b>Air flow meter</b>			
Resistor	Ω	E2—Vs	Fully closed: 20—400      Fully open: 20—1,000
		E2—Vc	100—300
		E2—VB	200—400
		E2—THA	-20°C ( -4°F)      10,000—20,000 20°C ( 68°F)      2,000—3,000 60°C (140°F)      400—700



Item	Transaxle type	Manual Transaxle	Automatic Transaxle
<b>Fuel pump</b>			
Type		Impeller (in tank)	
Output pressure	kPa (kg/cm <sup>2</sup> , psi)	441—588 (4.5—6.0, 64—85)	
Feeding capacity	cc (cu-in)/10 sec	220—380 (13.4—23.2) when fuel pressure at 250 kPa (2.55 kg/cm <sup>2</sup> , 36.3 psi)	
<b>Fuel filter</b>			
Type	Low pressure side	Nylon 6 (250 mesh) element	
	High pressure side	Paper element	
<b>Pressure regulator</b>			
Type		Diaphragm	
Regulating pressure	kPa (kg/cm <sup>2</sup> , psi)	240—279 (2.45—2.85, 34.8—40.5) (Vacuum hose disconnected)	
<b>Injector</b>			
Type		High-ohmic	
Type of drive		Voltage	
Resistance	Ω	11—15	
Injection amount	cc (cu in)/15 sec	32—41 (1.95—2.50)	
<b>Idle speed control valve</b>			
Solenoid resistance	Ω	5—20	
<b>Fuel tank</b>			
Capacity	liters (US gal, imp gal)	48 (12.7, 10.6)	
<b>Air cleaner</b>			
Element type		Wet	
<b>Accelerator cable</b>			
Free play	mm (in)	1—3 (0.039—0.118)	
<b>Fuel</b>			
Specification		Unleaded gasoline	

TIGHTENING TORQUE	N-m	m-kg	ft-lb
Intake manifold	19—26	1.9—2.6	14—19
Exhaust manifold	16—23	1.6—2.3	12—17

**4B. FUEL AND EMISSION CONTROL SYSTEM (B6 DOHC TURBO)**

Item	Engine model	B6 DOHC TURBO	
Idle speed	rpm	850 ± 50 in Neutral	
<b>Throttle body</b>			
Type		Horizontal draft (1-barrel)	
Throttle diameter	mm (in)	50 (1.9)	
<b>Air flow meter</b>			
Resistance	Ω	E2 — Vs	Fully closed: 20—400 Fully open: 20—1,000
		E2 — Vc	100—300
		E2 — VB	200—400
	E2 — THA	-20°C ( -4°F) 10,000—20,000 20°C ( 68°F) 2,000—3,000 60°C (140°F) 400—700	
<b>Fuel pump</b>			
Type		Impeller (intank)	
Output pressure	kPa (kg/cm <sup>2</sup> , psi)	441—588 (4.5—6.0, 64—85)	
Feeding capacity	cc (cu-in)/10 sec	220—380 (13.42—22.18)	
<b>Transfer pump</b>			
Feeding capacity	cc (cu-in)/10 sec	278—388 (16.95—23.7) when fuel pump pressure is at 196 kPa (kg/cm <sup>2</sup> )	

Item		Engine model	B6 DOHC TURBO
<b>Fuel filter</b>			
Type	Low pressure side		Nylon 6 (250 mesh) element
	High pressure side		Paper element
<b>Pressure regulator</b>			
Type			Diaphragm
Regulating pressure		kPa (kg/cm <sup>2</sup> , psi)	245—279 (2.5—2.85, 35.6—40.5)
<b>Injector</b>			
Type			High-ohmic
Type of drive			Voltage
Resistance $\Omega$			12—16
Injection amount		cc (cu-in)/15 sec	66—82 (4.0—5.0)
<b>Turbocharger</b>			
Type			Water cooled
Lubrication			Engine oil
Boost pressure (Max)		kPa (kg/cm <sup>2</sup> , psi)	55—59 (0.56—0.60, 8.0—8.6)
<b>Water gate valve</b>			
Operating pressure		kPa (kg/cm <sup>2</sup> , psi)	48.1—58.9 (0.49—0.54, 7.0—7.7)
<b>Idle speed control valve</b>			
Solenoid resistance		$\Omega$	5—20
<b>Fuel tank</b>			
Capacity		liters (US gal, Imp gal)	50 (13.2, 11)
<b>Air cleaner</b>			
Element type			Oil permeated
<b>Accelerator cable</b>			
Free play			1—3 (0.039—0.118)
<b>Fuel</b>			
Specification			Unleaded gasoline

TIGHTENING TORQUE		N-m	m-kg	ft-lb
Intake manifold		19—26	1.9—2.6	14—19
Exhaust manifold		39—57	4.0—5.8	29—42
Turbocharger	Connect to exhaust manifold	27.5—33.4	2.8—3.4	20.3—24.6
	Connect to exhaust pipe	24.5—32.4	2.5—3.3	18.1—23.9

## 5. ENGINE ELECTRICAL SYSTEM

Item		Engine model	B6 EGI	B6 DOHC TURBO
<b>Charging system</b>				
Battery 20 hour rate	Type		NS40ZAL, 50D20L, 55D23L	
	Voltage	V	12	
	Capacity	Ah	35 (NS40ZAL), 50 (50D20L), 60 (55D23L)	
Level of electrolyte			between "Upper" to "Lower"	
Safety gravity at 20°C (68°F)	Recharge at		1.20	
	Full charge		1.25—1.27 (NS40ZAL, 50D20L), 1.27—1.29 (55D23L)	
Charging current		A	3.3 (NS40ZAL), 5.0 (50D20L), 6.0 (55D23L)	
Alternator	Type		A.C	
	Voltage-Capacity	V-A	12-60	
Pulley ratio			1 : 2.2	

Engine model		B6 EGI	B6 DOHC TURBO
Regulator voltage	No load test/ Engine revolution	14.1—14.7V/2,500 rpm	
Brush	Number	2	
	Length mm (in)	16.5 (0.650)	
		Standard Wear limit	8.0 (0.315)
<b>Starting system</b>			
Starting motor	Type	Electromagnetic, pull in	
	Voltage	V	12
	Output	kw	0.85
Free running test	Voltage	V	11.5
	Current	A	60 or less
	Speed	rpm	6,500
Brush length mm (in)	Standard	17 (0.669)	
	Wear limit	11.5 (0.453)	
<b>Ignition system</b>			
Spark plug	DENSO	W16EXR-U11	Q20PR-U11
	NGK	BPR5ES-11	BCPR6E11
	CHAMPION	RN11YC4	—
Plug gap	mm (in)	1.0—1.1 (0.039—0.043)	
Ignition advance	Ignition timing BTDC (at idle)	2 ± 1°	
		(Vacuum hose: disconnected)	
	Approx 7°		
	(Vacuum hose: connected)		
	Centrifugal spark advance (Crank angle/Engine speed)	0°/1,300 rpm 19°/3,500 rpm 19°/5,000 rpm	0°/1,200 rpm 12°/3,500 rpm 12°/5,000 rpm 18°/5,500 rpm
Vacuum spark advance (Crank angle/vacuum)	A chamber 0°/75 mmHg (2.95 inHg) 28°/450 mmHg (17.72 inHg)	B chamber 0°/75 mmHg (2.95 inHg) 5°/150 mmHg (5.91 inHg)	0°/60 mmHg (2.36 inHg) 15°/450 mmHg (17.72 inHg)
Positive pressure spark advance (Crank angle/positive pressure)	—		0°/10.64 kPa (0.11 kg/cm <sup>2</sup> , 1.54 psi) -5°/53.2 kPa (0.54 kg/cm <sup>2</sup> , 7.7 psi)
Timing mark location	Timing belt cover		
Firing order	1-3-4-2		
<b>Ignition coil</b>			
Secondary coil resistance	kΩ	6—30	
High tension lead resistance	kΩ	16 per 1 m (3.28 ft)	
<b>Distributor</b>			
Type	Full transistor (HEI)		

## 6. CLUTCH

Item	Engine model	B6 DOHC TURBO		B6 EGI
		4WD	2WD	
Clutch control		Hydraulic		Cable
<b>Clutch pedal</b>				
Type		Suspended		
Pedal ratio		5.96		6.2
Full stroke	mm (in)	145 (5.71)		
Height	mm (in)	229 <sup>+5</sup> <sub>-8</sub> (9.02 <sup>+0.20</sup> <sub>-0.20</sub> )		214.5 <sup>+5</sup> <sub>-8</sub> (8.44 <sup>+0.20</sup> <sub>-0.20</sub> )
Free play	mm (in)	0.6—3.0 (0.02—0.12)		9—15 (0.35—0.59)
Distance to floor when clutch is fully disengaged	mm (in)	82 (3.23) min.		85 (3.3) min.
<b>Flywheel</b>				
Runout limit	mm (in)			0.2 (0.008)
Grinding limit	mm (in)			0.5 (0.020)
<b>Clutch disc</b>				
Type		Single dry plate		
Runout limit	mm (in)	1.00 (0.039)		
Wear limit	mm (in)	0.3 from rivet head (0.012)		
Outer diameter	mm (in)	225 (8.86)		190 (7.48)
Inner diameter	mm (in)	150 (5.91)		132 (5.20)
Facing thickness	mm (in)	Flywheel side	4.1 (0.16)	3.5 (0.14)
		Pressure plate side	3.5 (0.14)	
<b>Clutch cover</b>				
Set load	N (kg, lb)	4316 (440, 968)		3277 (334, 735)
Grinding limit	mm (in)	0.5 (0.020)		

TIGHTENING TORQUE			
Clutch cover	N·m (m·kg, ft·lb)	18—26 (1.8—2.7, 13—20)	
Flywheel	N·m (m·kg, ft·lb)	96—103 (9.8—10.5, 71—76)	
Release lever and fork	N·m (m·kg, ft·lb)	7.8—10.8 (0.8—1.1, 5.8—8.0)	

## 7A. MANUAL TRANSAXLE (F-type)

Item	Engine model	B6 EGI	
<b>Transaxle</b>			
Shift lever position		Floor shift	
Gear ratio	First	3.416	
	Second	1.842	
	Third	1.290	
	Fourth	0.918	
	Fifth	0.731	
	Reverse	3.214	
Fluid capacity	Liters (US qt, Imp qt)	3.2 (3.4, 2.8)	
Fluid type	Above -18°C (0°F)	API service GL-4 or GL-5 (SAE90 or 80W-90)	
	Below -18°C (0°F)	ATF (M2C33-F or DEXRON-II)	
Clearance of lever and reverse idle gear	mm (in)	Standard	0.095—0.318 (0.004—0.013)
		Wear limit	0.5 (0.020)
Clearance of shift fork and clutch hub sleeve	mm (in)	Standard	0.2—0.458 (0.008—0.018)
		Wear limit	0.5 (0.020)
Clearance of synchronizer ring and gear	mm (in)	Standard	1.5 (0.059)
		Wear limit	0.8 (0.031)

Item		Engine model	B6 EGI
Thrust clearance	First	Standard	0.14—0.37 (0.006—0.015)
		limit	0.42 (0.017)
	Second	Standard	0.245—0.58 (0.010—0.023)
		limit	0.63 (0.025)
	Third	Standard	0.095—0.38 (0.004—0.015)
		limit	0.43 (0.017)
	Fourth	Standard	0.09—0.4 (0.004—0.016)
		limit	0.45 (0.018)
	Fifth	Standard	0.15—0.262 (0.006—0.010)
		limit	0.31 (0.012)
Bearing preload of primary shaft gear		N-m (cm-kg, in-lb)	0.10—0.34 (1.0—3.5, 0.87—3.0)
Bearing preload adjustment shim		mm (in)	0.20 (0.008), 0.25 (0.010), 0.30 (0.012), 0.35 (0.014), 0.40 (0.016), 0.45 (0.018), 0.50 (0.020), 0.55 (0.022)
<b>Differential</b>			
Final gear	Type	Helical gear	
	Reduction ratio	3.850	
Side bearing preload		N-m (cm-kg, in-lb)	0.03—0.75 (0.3—7.6, 0.26—6.6)
Bearing preload adjustment shim		mm (in)	0.10 (0.004), 0.15 (0.006), 0.20 (0.008), 0.25 (0.010), 0.30 (0.012), 0.35 (0.014), 0.40 (0.016), 0.45 (0.018), 0.50 (0.020), 0.55 (0.022), 0.60 (0.024), 0.65 (0.026), 0.70 (0.028), 0.75 (0.030), 0.80 (0.031), 0.85 (0.033), 0.90 (0.035)
Backlash of side gear and pinion gear		mm (in)	0—0.1 (0—0.004)

TIGHTENING TORQUE		N-m	m-kg	ft-lb
Change arm		12—16	1.2—1.6	8.7—11.6
Guide plate	M6	8—11	0.8—1.1	5.8—8.0
	M10	19—28	1.9—2.9	13.7—21.0
Guide pin		8—12	0.8—1.2	5.8—8.7
Gate lock bolt		12—16	1.2—1.6	8.7—11.6
Transaxle case		19—26	1.9—2.6	13.7—18.8
Reverse idle shaft lock bolt		19—26	1.9—2.6	13.7—18.8
Interlock sleeve guide bolt		9—12	0.9—1.2	6.5—8.7
Gear shaft lock nut		128—206	13—21	94—152
Rear cover		8—11	0.8—1.1	5.8—8.0
Drain plug		39—54	4.0—5.5	29—40
Ring gear		69—83	7.0—8.5	51—61
Back-up light switch		25—34	2.5—3.5	18.1—25.3
Neutral switch		25—34	2.5—3.5	18.1—25.3

**7A. MANUAL TRANSAXLE (G-type)**

Item		Engine model	B6 DOHC TURBO
<b>Transaxle</b>			
Shift lever position			Floor shift
Gear ratio	First		3.307
	Second		1.833
	Third		1.233
	Fourth		0.970
	Fifth		0.795
	Reverse		3.166
Fluid capacity		Liters (US qt, Imp qt)	3.4 (3.6, 3.0)
Fluid type			ATF: DEXRON-II API: GL-4 or GL-5 (Above -18°C/0°F) SAE 80W-90 or SAE 90

Item		Engine model	B6 DOHC TURBO
<b>Clearance</b>			
Clearance of lever and reverse idle gear	mm (in)	Standard	0.1—0.32 (0.004—0.013)
		Wear limit	0.5 (0.020)
Clearance of shift fork and clutch sleeve	mm (in)	Standard	0.2—0.46 (0.008—0.018)
		Wear limit	0.5 (0.020)
Clearance of synchronizer ring and gear	mm (in)	Standard	1.5 (0.059)
		Wear limit	0.8 (0.021)
Each gear thrust clearance	First	Standard	0.05—0.53 (0.002—0.021)
		Limit	0.6 (0.024)
	Second	Standard	0.5—0.98 (0.020—0.039)
		Limit	1.0 (0.039)
	Third	Standard	0.05—0.425 (0.002—0.017)
		Limit	0.5 (0.020)
	Fourth	Standard	0.002—0.365 (0.0001—0.014)
		Limit	0.5 (0.020)
Bearing preload of primary shaft gear	N-m (in-lb)	0.05—0.2 (0.4—1.7)	
Bearing preload adjusting shim	mm (in)	0.20 (0.008), 0.30 (0.012), 0.40 (0.016), 0.50 (0.020), 0.25 (0.010), 0.35 (0.014), 0.45 (0.020), 0.55 (0.022), 0.60 (0.023), 0.65 (0.025), 0.70 (0.227)	
<b>Differential</b>			
Final gear	Type	Helical gear	
	Reduction ratio	4.105	
Side bearing preload	N-m (in-lb)	0.8—1.8 (6.9—15.6)	
Bearing preload adjust shim	mm (in)	0.1 (0.004), 0.2 (0.008), 0.3 (0.012), 0.4 (0.016), 0.5 (0.020), 0.6 (0.224), 0.8 (0.032), 0.15 (0.006), 0.25 (0.010), 0.35 (0.014), 0.45 (0.018), 0.55 (0.022), 0.65 (0.026), 0.75 (0.030), 0.85 (0.034)	
Backlash of side gear and pinion gear	mm (in)	0—0.1 (0.004)	

TIGHTENING TORQUE	N-m	m-kg	ft-lb
Gate lock bolt	12—16	1.3—1.6	8.7—11.6
Transaxle case	18—26	1.8—2.6	13.0—18.8
Rear cover	8—11	0.8—1.1	5.8—8.0
Gear shaft lock nut	128—206	13.0—21.0	94—152
Guide bolt	9—14	0.9—1.4	6.5—10.1
Reverse idle shaft lock bolt	21—30	2.1—3.0	15.2—22.4

## 7B. AUTOMATIC TRANSAXLE

Item		Transaxle model	FU 56
Model			FU 56
Gear ratio	First		2,800
	Second		1,540
	Third		1,000
	Overdrive (OD)		0,700
	Reverse		2,333
Fluid capacity	Liters (US qt, Imp qt)		6.3 (6.7, 5.5)
Fluid type			ATF Dexron II
Fluid level with the engine idling at P			Between F and L marks on gauge
<b>Stall revolution</b>			
After brake in	rpm		2,300—2,600

Transaxle model		FU 56	
Item			
<b>Line pressure</b>			
D range	Idle	kpa (kg/cm <sup>2</sup> , psi)	350—490 (3.6—5.0, 51—71)
	Stall	kpa (kg/cm <sup>2</sup> , psi)	980—1230 (10.0—12.5, 142—178)
2 and 1 range	Idle	kpa (kg/cm <sup>2</sup> , psi)	590—790 (6.0—8.0, 85—114)
	Stall	kpa (kg/cm <sup>2</sup> , psi)	980—1230 (10.0—12.5, 142—178)
R range	Idle	kpa (kg/cm <sup>2</sup> , psi)	600—830 (6.1—8.5, 87—121)
	Stall	kpa (kg/cm <sup>2</sup> , psi)	1470—1960 (15.0—20.0, 213—284)
<b>Throttle pressure</b>			
P range	Idle	kpa (kg/cm <sup>2</sup> , psi)	83—113 (0.85—1.15, 12—16)
	Stall	kpa (kg/cm <sup>2</sup> , psi)	540—610 (5.5—6.2, 5.5—6.2)
<b>Governor pressure</b>			
D range	30 km/h (19 mph)	kpa (kg/cm <sup>2</sup> , psi)	83—118 (0.85—1.20, 12—17)
	50 km/h (31 mph)	kpa (kg/cm <sup>2</sup> , psi)	162—206 (1.65—2.10, 23—30)
	85 km/h (53 mph)	kpa (kg/cm <sup>2</sup> , psi)	314—378 (3.2—3.85, 46—55)
<b>Shift point</b>			
Range	Throttle condition	Shifting	Shift point speed km/h (mph)
D	Fully opened	1st → 2nd	42—57 (26—35)
		2nd → 3rd	90—105 (56—65)
	Half throttle (1/2)	1st → 2nd	15—30 (9—19)
		2nd → 3rd	47—62 (29—38)
		3rd → OD	93—108 (58—67)
		Lock-up	93—108 (58—67)
	Kick-down	OD → 3rd	More than 75 (47)
		OD → 2nd	30—90 (19—56)
		OD → 1st	28—50 (17—31)
		3rd → 2nd	30—90 (19—56)
3rd → 1st		12—50 (7—31)	
1	Fully opened	2nd → 1st	7—50 (4—31)
		1st → 2nd	51—66 (32—41)
	Half throttle	1st → 2nd	51—66 (32—41)
		2nd → 1st	42—57 (26—35)
Kick-down	2nd → 1st	42—57 (26—35)	
	1st → 2nd	42—57 (26—35)	
<b>Time lag</b>			
N → D range		sec.	0.4—1.2
N → R range		sec.	0.4—1.5
<b>Torque converter</b>			
Stall torque ratio			2.100—2.300: 1
Bushing inner diameter	mm (in)	Standard	53.030 (2.088)
		Maximum	53.076 (2.090)
<b>Oil pump</b>			
Clearance			
Cam ring and oil pump cover	mm (in)	Standard	0.005—0.020 (0.0002—0.0008)
		Maximum	0.080 (0.003)
Rotor and oil pump cover	mm (in)	Standard	0.005—0.020 (0.0002—0.0008)
		Maximum	0.030 (0.0012)
Vane and oil pump cover	mm (in)	Standard	0.015—0.050 (0.0006—0.0020)
		Maximum	0.080 (0.003)
Seal pin and oil pump cover	mm (in)	Standard	0.005—0.020 (0.0002—0.0008)
		Maximum	0.060 (0.002)
Vane and rotor groove	mm (in)	Standard	0.010—0.045 (0.0004—0.0018)
		Maximum	0.065 (0.0026)

# 30 TECHNICAL DATA

Item		Transaxle model	FU 56
Sleeve outer diameter	mm (in)	Standard	28.00 (1.102)
Rotor bushing inner diameter	mm (in)	Standard	28.00 (1.102)
		Maximum	28.05 (1.104)
Seal pin outer diameter	mm (in)	Standard	5.00 (0.197)
		Minimum	4.90 (0.193)
Guide ring outer diameter	mm (in)	Standard	57.85 (2.278)
		Minimum	57.70 (2.272)
Valve outer diameter	mm (in)	Standard	12.00 (0.472)
		Minimum	11.86 (0.467)
<b>Forward clutch</b>			
Number of driven and drive plates			3
Drive plate thickness	mm (in)	Standard	1.6 (0.063)
		Minimum	1.4 (0.055)
Forward clutch clearance	mm (in)		1.0—1.2 (0.039—0.047)
Retaining plate sizes	mm (in)		5.9 (0.232), 6.1 (0.240), 6.3 (0.248), 6.5 (0.256), 6.7 (0.264), 8.9 (0.350)
<b>Coasting clutch</b>			
Number of driven and drive plates			2
Drive plate thickness	mm (in)	Standard	1.6 (0.063)
		Minimum	1.4 (0.055)
Coasting clutch clearance	mm (in)		1.0—1.2 (0.039—0.047)
Retaining plate sizes	mm (in)		4.6 (0.181), 4.8 (0.189), 5.0 (0.197), 5.2 (0.205), 5.4 (0.213), 5.6 (0.220)
Return spring free length	mm (in)		29.8 (1.173)
<b>Reverse clutch</b>			
Number of driven and drive plates			2
Drive plate thickness	mm (in)	Standard	1.6 (0.063)
		Minimum	1.4 (0.055)
Reverse clutch clearance	mm (in)		2.1—2.4 (0.083—0.094)
Retaining plate sizes	mm (in)		6.8 (0.268), 7.0 (0.276), 7.2 (0.283), 7.4 (0.291), 6.6 (0.260), 7.6 (0.299)
<b>3-4 clutch</b>			
Number of driven and drive plates			4
Drive plate thickness	mm (in)	Standard	1.6 (0.063)
		Minimum	1.4 (0.055)
3-4 clutch clearance	mm (in)		1.3—1.5 (0.051—0.059)
Retaining plate sizes	mm (in)		4.8 (0.189), 5.0 (0.197), 5.2 (0.205), 5.4 (0.213), 5.6 (0.220)
Return spring free length	mm (in)		33.2 (1.307)
<b>Low and reverse brake</b>			
Number of driven and drive plates			3
Drive plate thickness	mm (in)	Standard	1.6 (0.063)
		Minimum	1.4 (0.055)
Low and reverse brake clearance	mm (in)		2.1—2.4 (0.083—0.094)
Retaining plate sizes	mm (in)		10.2 (0.402), 10.4 (0.409), 10.6 (0.417), 10.8 (0.425), 10.0 (0.394)
Return spring free length	mm (in)		20.5 (0.807)
Sun gear drum bush	mm (in)	Maximum	33.425 (1.316)
Small sun gear bush	mm (in)	Maximum	24.021 (0.946)
<b>Carrier hub</b>			
Clearance between pinion washer and planetary carrier		mm (in)	0.2—0.7 (0.008—0.028)
<b>Servo</b>			
Free length of return spring	mm (in)		43.25 (1.703)
<b>2-3 accumulator valve</b>			
2-3 accumulator valve spring	mm (in)	Outer dia.	8.9 (0.350)
		Free length	76 (2.992)



Spring name	Outer dia. mm (in)	Free length mm (in)	Wire dia. mm (in)	Spring color
1-2 accumulator small spring	9.9 (0.400)	84.7 (3.335)	1.2 (0.047)	Red
1-2 accumulator large spring	16.0 (0.630)	78.0 (3.071)	2.0 (0.079)	Blue
Bypass spring	5.0 (0.197)	25.1 (0.988)	0.7 (0.028)	Yellow
Servo control spring	4.9 (0.193)	27.1 (1.067)	0.5 (0.020)	—
2-3 timing spring	8.3 (0.327)	26.5 (1.043)	0.8 (0.031)	—
N-R accumulator rear spring	11.1 (0.437)	68.2 (2.685)	1.0 (0.039)	Blue
N-D accumulator front spring	9.8 (0.386)	99.9 (3.933)	1.2 (0.047)	Silver
Low reducing spring	8.7 (0.343)	38.3 (1.508)	0.9 (0.035)	Black
OD release spring	6.0 (0.236)	32.6 (1.283)	0.6 (0.024)	—
Coasting bypass spring	5.8 (0.228)	31.3 (1.232)	0.6 (0.024)	—
3-2 timing spring	8.2 (0.323)	28.55 (1.124)	0.8 (0.031)	Maroon
3-2 capacity spring	5.55 (0.219)	30.5 (1.201)	0.55 (0.022)	—
Throttle relief ball spring	6.6 (0.260)	20.3 (0.799)	0.8 (0.031)	—
1-2 shift control spring	5.5 (0.217)	46.0 (1.811)	0.5 (0.020)	—
1-2 shift spring	5.0 (0.197)	30.9 (1.217)	0.5 (0.020)	—
2-3 shift spring	6.1 (0.240)	45.4 (1.787)	0.65 (0.026)	Maroon
3-4 shift spring	6.4 (0.252)	37.0 (1.457)	0.6 (0.024)	—
Throttle backup spring	6.4 (0.252)	33.5 (1.319)	0.6 (0.024)	—
Throttle modulator front spring	5.0 (0.197)	27.8 (1.094)	0.6 (0.024)	Red
Throttle modulator rear spring	7.15 (0.281)	30.8 (1.213)	0.85 (0.033)	Red
1 range control spring	6.15 (0.242)	39.2 (1.543)	0.65 (0.026)	—
2 range control spring	3.95 (0.156)	32.1 (1.264)	0.45 (0.018)	—
Kick-down spring	5.4 (0.213)	38.1 (1.500)	0.8 (0.031)	—
Throttle assist spring	5.15 (0.203)	32.3 (1.272)	0.55 (0.022)	Dark green
Throttle spring	5.4 (0.213)	48.3 (1.902)	0.8 (0.031)	—
Converter relief ball spring	6.9 (0.272)	24.1 (0.949)	0.9 (0.035)	Maroon
Orifice check valve spring	5.0 (0.197)	12.5 (0.492)	0.23 (0.009)	—
Pressure regulator spring	9.5 (0.374)	30.7 (1.209)	0.7 (0.028)	—
Lock-up control spring	6.8 (0.268)	46.5 (1.831)	0.9 (0.035)	—
Lock-up support spring	6.1 (0.240)	43.5 (1.713)	0.65 (0.026)	Blue
OD lock-up spring	7.1 (0.280)	69.2 (2.724)	0.8 (0.031)	Red

Transaxle model		FU 56
<b>Item</b>		
<b>Gear assembly</b>		
Total end play	mm (in)	0.25—0.50 (0.010—0.020)
End play adjusting races	mm (in)	1.2 (0.047), 1.4 (0.055), 1.6 (0.063), 1.8 (0.071), 2.0 (0.079), 2.2 (0.087)
Idle gear bearing preload	N·m (cm·kg, in·lb)	0.03—0.9 (0.3—9.0, 0.26—7.81)
Preload adjusting shims	mm (in)	0.10 (0.004), 0.12 (0.005), 0.14 (0.006), 0.16 (0.0063), 0.18 (0.007), 0.20 (0.008), 0.50 (0.020)
Output gear bearing preload	N·m (cm·kg, in·lb)	0.03—0.9 (0.3—9.0, 0.26—7.81)
Preload adjusting shims	mm (in)	0.10 (0.004), 0.12 (0.005), 0.14 (0.006), 0.16 (0.0063), 0.18 (0.007), 0.20 (0.008), 0.50 (0.020)
<b>Drive and differential</b>		
Final gear	Type	Helical gear
	Reduction ratio	3.842
Side bearing preload	N·m (cm·kg, in·lb)	2.9—3.9 (30—40, 26—35)
Preload adjusting shims	mm (in)	0.10 (0.004), 0.12 (0.005), 0.14 (0.006), 0.16 (0.0063), 0.18 (0.007), 0.20 (0.008), 0.30 (0.012), 0.40 (0.016), 0.50 (0.020), 0.60 (0.024), 0.70 (0.028), 0.80 (0.031), 0.90 (0.035)
Backlash of side gear and pinion	mm (in)	0.025—0.1 (0.001—0.004)
Torque converter distance "A" (Refer to 7B—160)	mm (in)	25 (0.98)

## 7C. MANUAL TRANSAXLE (4WD)

Item	Engine model	B6 DOHC TURBO	
<b>Transaxle</b>			
Shift lever position		Floor shift	
Gear ratio	First	3.307	
	Second	1.833	
	Third	1.233	
	Fourth	0.970	
	Fifth	0.795	
	Reverse	3.106	
Clearance of lever and reverse idle gear mm (in)	Standard	0.1—0.32 (0.004—0.013)	
	Wear limit	0.5 (0.02)	
Clearance of shift fork and clutch hub sleeve mm (in)	Standard	0.2—0.46 (0.008—0.018)	
	Wear limit	0.5 (0.02)	
Clearance of synchronizer ring and gear mm (in)	Standard	1.5 (0.059)	
	Wear limit	0.8	
Thrust clearance mm (in)	First	Standard	0.050—0.280 (0.002—0.011)
		Limit	0.330 (0.013)
	Second	Standard	0.175—0.455 (0.007—0.018)
		Limit	0.505 (0.020)
	Third	Standard	0.050—0.200 (0.002—0.008)
		Limit	0.250 (0.039)
	Fourth	Standard	0.165—0.365 (0.065—0.144)
		Limit	0.415 (0.016)
	Fifth	Standard	0.050—0.175 (0.002—0.007)
		Limit	0.225 (0.010)
Bearing preload	Primary shaft gear Nm (cm-kg, in-lb)	0.1—0.34 Nm (1.0—3.5, 0.87—3.00)	
	Adjustment shim mm (in)	0.20 (0.008), 0.30 (0.012), 0.40 (0.0160), 0.50 (0.020), 0.25 (0.010), 0.35 (0.014), 0.45 (0.020), 0.55 (0.022), 0.60 (0.023), 0.65 (0.025), 0.70 (0.227)	
Fluid	Type	ATF: DEXRON-II API: GL-4 or GL-5 (Above -18°C/0°F) SAE 80W-90 or SAE 90	
	Capacity	3.6 liters (3.8 US qt, 3.2 Imp qt)	
<b>Center differential</b>			
Type		Planetary carrier	
Number of ring gear teeth	Outer	78	
	Inner	66	
Number of pinion gear teeth	Outer	14	
	Inner	14	
Number of sun gear teeth	Pinion gear side	33	
	Idle gear side	50	
Number of idle gear teeth		43	
Bearing preload	Nm (cm-kg, in-lb)	0.3—1.2 (3—12, 2.6—10.4)	
Bearing preload adjustment shim	mm (in)	0.1 (0.004), 0.2 (0.008), 0.3 (0.012), 0.4 (0.016), 0.5 (0.020), 0.6 (0.024), 0.7 (0.028), 0.8 (0.032), 0.9 (0.036), 1.0 (0.040), 1.1 (0.044), 1.2 (0.048)	
End play of ring gear	mm (in)	0.15—0.30 (0.006—0.012)	
Ring gear end play adjustment washer	mm (in)	1.20 (0.047), 1.35 (0.053), 1.50 (0.059), 1.65 (0.065), 1.80 (0.071)	
End play of sun gear	mm (in)	0.10—0.30 (0.004—0.012)	
Sun gear adjustment washer	mm (in)	3.5 (0.138), 3.7 (0.146), 3.9 (0.154), 4.1 (0.162), 4.3 (0.170)	

Item	Engine model	B6 DOHC TURBO
<b>Transfer Carrier</b>		
Final gear reduction ratio		4.105
Number of teeth	Ring gear	78
	Secondary shaft final gear	19
Fluid	Type	API: GL-5 Above -18°C (0°F): SAE 90 Below -18°C (0°F): SAE 80W
	Capacity	0.5 liter (0.5 US qt, 0.4 Imp qt)

TIGHTENING TORQUE	N-m	m-kg	ft-lb
Transaxle case	37—52	3.8—5.3	27—38
Gear shaft lock nut	127—206	12.9—21	94—152
Rear cover	7.8—11	0.8—1.1	5.8—8.3
Transfer carrier	25—30	2.5—3.1	18.1—22.4
Center differential lock motor	18.6—25.5	1.9—2.6	13.7—18.8
Gate lock bolt	12—16	1.2—1.6	10.4—13.9
Reverse idle shaft lock bolt	19—26	1.9—2.7	13.7—18.8
Switches	19.6—29.4	2.0—3.0	14.5—21.7
Inter lock sieve guide bolt	8.8—13.7	0.9—1.4	6.5—10.1
Drain plug	39—59	4.0—6.0	29—43

## 8. PROPELLER SHAFT

Item	Front propeller shaft	Rear propeller shaft
Length	857.3 (33.75)	965 (37.99)
Shaft outer diameter	57 (2.24)	65 (2.56)
Deflection limit	0.4 (0.016)	
Starting torque of the universal joint	0.294—0.784 (3—8, 2.6—6.9)	

TIGHTENING TORQUE	N-m	m-kg	ft-lb
Companion flange (front)	27—30	2.8—3.1	20—22
Companion flange (rear)	27—30	2.8—3.1	20—22
Center bearing support	37—52	3.8—5.3	27—38

## 9. FRONT AND REAR AXLES

Item				
<b>Driveshaft</b>				
Joint type		Inside	Double offset joint	
		Outside	Bell joint	
Shaft length	mm (in)	front	Right side	564 (22.20)
			Left side	629 (24.76)
	rear	Right side	681.2 (26.82)	
		Left side	651.3 (25.64)	
Shaft diameter		mm (in)	20.0 (0.787)	
<b>Front axle</b>				
Bearing play—axial direction		mm (in)	0	
Bearing preload		Pull scale reading N (kg, lb)	2.0—8.8 (0.2—0.9, 0.4—2.0)	
Preload adjustment spacer		mm (in)	6.285 (0.2474), 6.325 (0.2490), 6.365 (0.2506), 6.405 (0.2522), 6.445 (0.2538), 6.485 (0.2554), 6.525 (0.2569), 6.565 (0.2585), 6.605 (0.2600), 6.645 (0.2616), 6.685 (0.2631), 6.725 (0.2648), 6.765 (0.2663), 6.805 (0.2679), 6.845 (0.2695), 6.885 (0.2711), 6.925 (0.2726), 6.965 (0.2742), 7.005 (0.2758), 7.045 (0.2774), 7.085 (0.2789)	
<b>Rear axle</b>				
Bearing end play		mm (in)	0	
<b>Rear differential</b>				
Reduction gear		Hypoid gear		
Differential gear		Straight bevel gear		
Reduction ratio		3.909 : 1		
Number of teeth	Ring gear		43	
	Drive pinion gear		11	
Fluid	Grade		API Service GL-5	
	Viscosity		SAE 90 or 80W-90	
	Capacity: liter (US qt, imp qt)		0.65 (0.69, 0.57)	

TIGHTENING TORQUE	N-m	m-kg	ft-lb
Knuckle to shock absorber	93—117	9.5—11.9	69—86
Knuckle to lower arm ball joint	43—54	4.4—5.5	32—40
Lower arm to lower ram ball joint	93—117	9.5—11.9	69—86
Knuckle to brake assembly	39—49	4.0—5.0	29—36
Knuckle to tie rod end	29—44	3.0—4.5	22—35
Disc plate to wheel hub	44—54	4.5—5.5	33—40
Hub spindle to shock absorber	93—117	9.5—11.9	69—86
Lateral link through bolt	63—75	6.4—7.6	46—55
Hub spindle to backing plate	45—67	4.6—6.8	33—49

## 10. STEERING SYSTEM

Item	Model	4WD	2WD
<b>Steering wheel</b>			
Outer diameter	mm (in)	380 (14.96)	
Free play	mm (in)	0—30 (0—1.18)	
Operating force	N (kg, lb)	M/S : 5—20 (0.5—2.0, 1—5) P/S : 40 (4.1, 9)	

Item		Model	4WD	2WD
Lock to lock			P/S : 2.9	M/S : 3.6 (C.G.R.) 4.2 (V.G.R.) P/S : 3.2
Max. steering angle	Inner		39°00' ± 2°	40°00' ± 2°
	Outer		31°00' ± 2°	33°00' ± 2°
<b>Front wheel alignment</b>				
King-pin inclination angle			12°05'	12°20'
Camber angle			1°00' ± 30'	0°50' ± 30'
Caster angle			1°45' ± 45'	1°35' ± 45'
Caster trail		mm (in)	8.3 (0.33)	10.0 (0.39)
Toe-in		mm (in)	2 ± 3 (0.08 ± 0.12)	
<b>Steering gear</b>				
Type			Rack and pinion	
Total gear ratio			P/S : 17.0	M/S : 19.84 (C.G.R.), P/S : 17.6 M/S : 20.1—23 (V.G.R.)
Back lash between rack and pinion		mm (in)	0 (0)	
Pinion preload	N-m (cm-kg, in-lb)		M/S : 1.0—1.4 (10—14, 8.68—12.15) P/S : 0.6—1.5 (6—15, 5.2—13.02)	
	Preload measured by torque wrench			
	N (kg, lb)		M/S : 10—14 (1—1.4, 2.2—3.1) P/S : 6—15 (0.6—1.5, 1.3—3.3)	
		Preload measured by pull scale with attachment		
Limit of rack housing movement		mm (in)	1.5 (0.06)	
Distance between left and right brackets		mm (in)	257.5 (10.14)	260 (10.24)
Rack stroke		mm (in)	140 (5.51)	136 (5.35)
Lubricant type (power steering)			ATF DEXRON-II	ATF M2C33-F or Dexron-II
Oil capacity (power steering)		Liter (US qt, Imp qt)	0.6 (0.63, 0.53)	
<b>Drive belt</b>				
Deflection with force of 98 N (10 kg, 22 lb)		mm (in)	New belt 8—9 (0.31—0.35) Used belt 9—10 (0.35—0.39)	

C.G.R.: Constant Gear Ratio

V.G.R.: Variable Gear Ratio

TIGHTENING TORQUE			N-m	m-kg	ft-lb
Steering wheel nut			40—50	4.0—5.0	29—36
Steering housing to body	4WD	Upper	37—52	3.8—5.3	27—38
		Lower	31—46	3.2—4.7	23—34
	2WD	Upper	31—46	3.2—4.7	23—34
		Lower	31—46	3.2—4.7	23—34
Tie-rod end			29—44	3.0—4.5	29—33
Tie-rod locknut	4WD		34—50	3.5—5.1	25—37
	2WD		34—29	3.5—4.0	25—29
Pinion shaft to intermediate shaft			18—26	1.8—2.7	13—20
Steering shaft to master cylinder bracket	Steering wheel side		8.8—14	0.9—1.4	6.5—10
	Intermediate shaft side		16—23	1.6—2.3	12—17
Steering shaft to intermediate shaft			18—26	1.8—2.7	13—20

## 11. BRAKING SYSTEM

Item		Model	4WD & 2WD
Brake type			Front ..... disc, Rear ..... disc or drum
<b>Brake pedal</b>			
Height	mm (in)		214 ± <sub>5</sub> (8.43 ± <sub>5</sub> )
Free play	mm (in)		4—7 (0.16—0.28)
Reserve travel	mm (in)		83 (3.27) or more
Clearance when pedal is depressed at 589 N (60 kg, 132 lb)			

# 30 TECHNICAL DATA

Item		Model	4WD & 2WD
<b>Master cylinder</b>			
Master cylinder	Type		Tandem
	Bore diameter	mm (in)	22.22 (0.875)
Fluid capacity of reserve tank		cc (cu in)	195 (11.90)
<b>Front disc brake</b>			
Type		Ventilated	
Thickness of pad	mm (in)	Standard	10 (0.39)
		Minimum	2 (0.08)
Thickness of disc plate	mm (in)	Standard	18 (0.71)
		Minimum	16 (0.63)
Run-out of disc plate		mm (in)	0.1 (0.003)
Wheel cylinder bore		mm (in)	51.1 (2.01)
<b>Rear brake (disc)</b>			
Type		Solid	
Thickness of pad	mm (in)	Standard	8 (0.31)
		Minimum	1 (0.04)
Thickness of disc plate	mm (in)	Standard	10 (0.39)
		Minimum	8 (0.31)
Run-out of disc plate		mm (in)	0.1 (0.003)
Wheel cylinder bore		mm (in)	30.2 (1.19)
<b>Rear brake (drum)</b>			
Type		Leading & trailing	
Thickness of lining	mm (in)	Standard	5 (0.20)
		Minimum	1 (0.04)
Drum inside diameter	mm (in)	Standard	200 (7.87)
		Minimum	201 (7.91)
Wheel cylinder bore		mm (in)	17.46 (0.687)
<b>Parking brake</b>			
Type		Mechanical two rear wheel control	
Parking lever notches		5—7	
When lever is pulled at 98N (10 kg, 22 lb)			
<b>Power brake unit</b>			
Diameter		mm (in)	213 (8.39)
Clearance between master cylinder piston and push rod		mm (in)	0 (0)
Fluid pressure per treading force		kPa (kg/cm <sup>2</sup> , psi)	1,373 (14,199)
Pedal force 196N (20 kg, 44 lb), during non-booster action			
<b>Rear wheel hydraulic control system</b>			
Type		Dual proportioning valve	
Switching point (Master cylinder pressure)		kPa (kg/cm <sup>2</sup> , psi)	B6 EGI, B6 DOHC 4WD: 2,943 (30, 427) B6 DOHC 2WD : 3,434 (35, 498)

TIGHTENING TORQUE	N-m	m-kg	ft-lb
Master cylinder to power brake unit	19—25	1.9—2.6	14—19
Power brake unit to body	9.8—16	1.0—1.6	7.2—12
Brake pedal to master cylinder bracket	20—34	2.0—3.5	14—25
Front caliper to knuckle	49—59	5.0—6.0	36—43
Back plate to hub spindle	45—59	4.6—6.0	33—43
Mounting support to adaptor (2WD)	49—69	5.0—7.0	36—51
Mounting support to knuckle (4WD)	49—69	5.0—7.0	36—51
Rear caliper to mounting support	16—24	1.6—2.4	12—17
Wheel cylinder to back plate	9.8—13	1.0—1.3	7.2—9.4
Flexible hose to caliper	22—29	2.2—3.0	16—22
Flare nut	13—22	1.3—2.2	9—16

## 12. WHEEL AND TIRE

Item		Model	4WD & 2WD
<b>Wheel</b>			
Size		Standard: 4 1/2-Jx13, 5-Jx13, 5 1/2-JJx14 Temporary spare: 4-T x 14	
Offset	mm (in)	Standard: 45 (1.77)	Temporary spare: 50 (1.97)
Diameter of pitch circle		114.3 (4.5)	
<b>Tire</b>			
Size		Standard: 155SR13, P155/80R13, 175/70SR13, P175/70R13, 185/60R14 82H Temporary spare: T105/70D14	
Inflation pressure	kPa (kg/cm <sup>2</sup> , psi)	Front	Standard: 196 (2.0, 29) Temporary spare: 412 (4.2, 60)
		Rear	Standard: 177 (1.8, 26) Temporary spare: 412 (4.2, 60)
<b>Wheel and tire</b>			
Runout limit	mm (in)	Horizontal	Steel wheel: 2.5 (0.098) Aluminum wheel: 2.0 (0.079)
		Vertical	1.5 (0.059)
Unbalance limit		13 inch: 11 (0.39), 14 inch: 10 (0.35)	

TIGHTENING TORQUE	N-m	m-kg	ft-lb
Wheel lug nut	88—118	9—12	65—87

## 13. SUSPENSION 2WD (B6 EGI)

Item		Model	M/T	A/T
<b>Front suspension</b>				
Type		Strut		
Spring		Coil		
Spring dimensions	Wire diameter	mm (in)	12.5 (0.49)	12.8 (0.50)
	Coil diameter	mm (in)	132.5—134.7 (5.22—5.30)	134.3—136.4 (5.29—5.37)
	Free length	mm (in)	391 (15.4)	372 (14.6)
	Coil number (active)		4.96	5.60
Shock absorber		Cylindrical double-acting		
Stabilizer	Type		Torsion bar	
	Diameter	mm (in)	27.2 (1.07)	

Item		Model	Hatchback	Sedan
<b>Rear suspension</b>				
Type			Strut	
Spring			Coil	
Spring dimensions	Wire diameter	mm (in)	10.2 (0.40)	10.5 (0.41)
	Coil diameter	mm (in)	112.5 (4.43)	113.2 (4.46)
	Free length	mm (in)	351 (13.8)	376 (14.8)
	Coil number (active)		4.62	5.62
Shock absorber			Cylindrical double-acting	
Stabilizer	Type		Torsion bar	
	Diameter	mm (in)	15.9 (0.63)	

## 2WD (B6 DOHC Turbo)

Item		Type	Hard	ASA
<b>Front suspension</b>				
Type			Strut	
Spring			Coil	
Spring dimensions	Wire diameter	mm (in)	12.8 (0.50)	12.5 (0.49)
	Coil diameter	mm (in)	134.3—136.4 (5.29—5.37)	133.0—135.5 (5.24—5.33)
	Free length	mm (in)	372 (14.6)	393 (15.5)
	Coil number (active)		5.60	4.07
Shock absorber			Cylindrical double-acting	
Stabilizer	Type		Torsion bar	
	Diameter	mm (in)	29.2 (1.15)	
<b>Rear suspension</b>				
Type			Strut	
Spring			Coil	
Spring dimensions	Wire diameter	mm (in)	10.2 (0.40)	10.0 (0.39)
	Coil diameter	mm (in)	113.2 (4.46)	113.0 (4.45)
	Free length	mm (in)	351 (13.8)	394.6 (15.54)
	Coil number (active)		4.62	
Shock absorber			Cylinder double-acting	
Stabilizer	Type		Torsion bar	
	Diameter	mm (in)	Hatchback: 15.9 (0.63) Sedan: 17.3 (0.68)	17.3 (0.68)

ASA: Adjustable Shock Absorber

## 4WD (B6 DOHC Turbo)

Item		Type	Hard
<b>Front suspension</b>			
Type			Strut
Spring			Coil
Spring dimensions	Wire diameter	mm (in)	11.25 (0.44)
	Coil diameter	mm (in)	135 (5.31)
	Free length	mm (in)	436 (17.16)
	Coil number (active)		5.2
Shock absorber			Cylindrical double-acting
Stabilizer	Type		Torsion bar
	Diameter	mm (in)	29.2 (1.15)



Item	Type	Sporty
<b>Rear suspension</b>		
Type		Strut
Spring		Coil
Spring dimensions	Wire diameter mm (in)	10.5 (0.41)
	Coil diameter mm (in)	128 (5.04)
	Free length mm (in)	356.8 (14.05)
	Coil number (active)	3.65
Shock absorber		Cylindrical double-acting
Stabilizer	Type	Torsion bar
	Diameter mm (in)	15.9 (0.63)

TIGHTENING TORQUE		N-m	m-kg	ft-lb
<b>Front Suspension</b>				
Piston rod to mounting block	4WD	64—80	6.5—8.2	47—59
	2WD	55—68	5.6—6.9	41—50
Mounting block to suspension tower		29—36	3.0—3.7	22—27
Strut (lower) to knuckle		93—117	9.5—11.9	69—86
Knuckle arm to lower arm		43—54	4.4—5.5	32—40
Lower arm bushing (front)		93—117	9.3—11.9	69—86
Lower arm bushing (rear)		75—93	7.6—9.5	55—69
Lower arm bushing bracket (rear)		58—74	6.0—7.5	43—54
Stabilizer to lower arm		12—18	1.2—1.8	8.7—13
Stabilizer bracket (upper)		39—55	4.0—5.6	29—41
Stabilizer bracket (lower)		31—46	3.2—4.7	23—34
<b>Rear Suspension</b>				
Piston rod to mounting block	4WD	64—80	6.5—8.2	47—59
	2WD	55—68	5.6—6.9	41—50
Mounting block to suspension tower		23—29	2.3—3.0	17—22
Strut (lower) to knuckle (4WD)		78—117	8.0—11.9	58—86
Strut (lower) to hub spindle (2WD)		93—117	9.5—11.9	69—86
Lateral link to crossmember	4WD	68—95	6.9—9.7	50—70
	2WD	93—117	9.5—11.9	69—86
Lateral link to knuckle (4WD)		63—75	6.4—7.6	46—55
Lateral link to hub spindle (2WD)		63—75	6.4—7.6	46—55
Lateral link rod locknut (4WD)		55—64	5.6—6.5	41—47
Trailing link to body		59—74	6.0—7.5	43—54
Trailing link to knuckle (4WD)		93—117	9.5—11.9	69—86
Trailing link to hub spindle (2WD)		54—69	5.5—6.9	40—50
Crossmember to body	4WD	48—95	6.9—9.7	50—70
	2WD	46—57	4.7—5.8	34—42
Stabilizer to lateral link		12—18	1.2—1.8	8.7—13
Stabilizer bracket		43—54	4.4—5.5	32—40

## 15. BODY ELECTRICAL SYSTEM

Item	Wattage (Bulb Trade number)	
Halogen headlights	65/45 (9004)	
Turn signal lights	Front	27 (1156)
	Rear	27 (1157 NA)
Stop and tail lights	27/8 (1157)	
Parking/Front side marker lights	8 (67)	

Item	Wattage (Bulb Trade number)	
	With Tachometer	Without Tachometer
License plate lights	8 (67)	
Back-up light	27 (1156)	
High mounted stop light	18.4 (1141)	
Rear side marker lights	4.9 (168)	
Interior light	10	
Map lights	6	
Luggage compartment light	5	
Courtesy lights	3.4	
<b>Indicator and warning lights</b>	With Tachometer	Without Tachometer
Turn signal	3.4 (Analog), 1.4 (Digital)	
High beam	3.4 (Analog), 1.4 (Digital)	
Oil pressure	1.4	3.4
Alternator	1.4	3.4
Hazard	3.4 (Analog), 1.4 (Digital)	
Rear window defroster (if equipped)	1.4	3.4
Brake fluid level	1.4	3.4
Check (MIL)	3.4 (Analog), 1.4 (Digital)	3.4
A/C switch (if equipped)	1.4	
Stop light	1.4	—
Turbo	3.4	—
O/D OFF	1.4	—
Fuel level	3.4 (Analog), 1.4 (Digital)	—
Washer fluid level	1.4	—
Seat belt	1.4	3.4
<b>Illumination lights</b>		
Heater	3.4	
Cigarette lighter	3.4	
Radio	1.4	
Clock	1.4	
Cluster switch	1.4	
Automatic selector lever	3.4	
ASA switch	1.4	
Meter	3.4 (Analog), 1.4 (Digital)	
A/C switch (if equipped)	1.4	

## STANDARD BOLT AND NUT TIGHTENING TORQUE

Diameter mm (in)	Pitch mm (in)	4T			6T			8T		
		N-m	m-kg	ft-lb	N-m	m-kg	ft-lb	N-m	m-kg	ft-lb
6 (0.236)	1 (0.039)	4.2—6.2	0.43—0.63	3.1—4.6	6.9—9.8	0.7—1.0	5.0—7.2	7.8—11.8	0.8—1.2	5.8—8.8
8 (0.315)	1.25 (0.049)	9.8—14.7	1.0—1.5	7.2—10.8	16—23	1.6—2.3	12—17	18—26	1.8—2.7	13—20
10 (0.394)	1.25 (0.049)	20—28	2.0—2.9	14—21	31—46	3.2—4.1	23—34	36—54	3.7—5.5	27—40
12 (0.472)	1.5 (0.059)	34—50	3.5—5.1	25—37	55—80	5.6—8.2	41—59	63—93	6.4—9.5	46—69
14 (0.551)	1.5 (0.059)	—	—	—	75—103	7.7—10.5	56—76	102—137	10—14	75—101
16 (0.630)	1.5 (0.059)	—	—	—	116—157	12—16	85—116	156—211	16—22	115—156
18 (0.709)	1.5 (0.059)	—	—	—	167—225	17—23	123—166	221—299	23—31	163—221
20 (0.787)	1.5 (0.059)	—	—	—	231—314	24—32	171—231	308—417	31—43	227—307
22 (0.866)	1.5 (0.059)	—	—	—	314—423	32—43	231—312	417—564	43—58	307—416
24 (0.945)	1.5 (0.059)	—	—	—	475—546	41—56	298—403	536—726	55—74	396—536

# SPECIAL TOOLS

GENERAL INFORMATION.....	40— 2
ENGINE GROUP .....	40— 3
CLUTCH AND MANUAL TRANSAXLE GROUP .....	40— 4
AUTOMATIC TRANSAXLE GROUP .....	40— 6
PROPELLER SHAFT AND DIFFERENTIAL GROUP .....	40— 6
BRAKE AND AXLE GROUP.....	40— 7
STEERING AND SUSPENSION GROUP .....	40— 8
TESTER AND OTHER GROUP.....	40— 9

73G40X-001

## GENERAL INFORMATION

The letters in the Priority Column indicate the degree of importance of each tool.

A ..... Indispensable

The tools ranked "A" in this list are indispensable for performing operations satisfactorily, easily and efficiently and so it is advisable that all service shops have these tools.

B ..... Selective

The tools in this list are not as necessary as tools ranked A, but all service shops should have these tools if possible in order to easily perform operations for efficient repair operations.



86U40X-002

### Note

**When ordering tool sets which consist of several tools, check the List in the Parts Catalogue or Special Service Tools Booklet (4063-11-85B) etc. to make sure that some tools are duplicated in other sets which may already have been purchased. If so, order only those new tools which are needed.**

73G40X-002

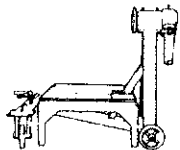
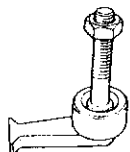
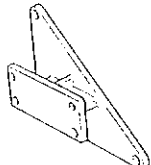
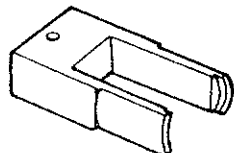
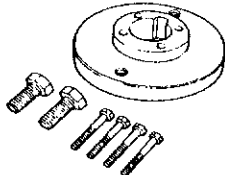
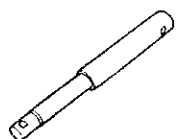
ENGINE GROUP

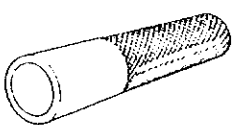
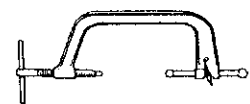
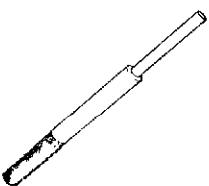
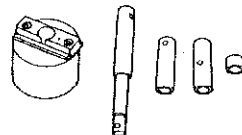
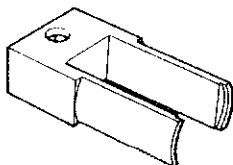
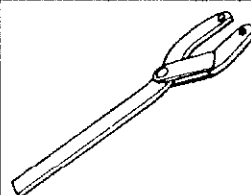
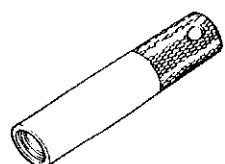

TOOL NUMBER & DESCRIPTION	PRIORITY	ILLUSTRATION	TOOL NUMBER & DESCRIPTION	PRIORITY	ILLUSTRATION
49 0107 680A Engine stand	A		49 E301 060 Brake, ring gear	A	
49 B010 1A0 Hanger, engine stand	A		49 S120 222 (B6 EGI) Pivot, valve spring lifter	A	
49 B011 102 Lock tool, crankshaft	A		49 0221 061A (B6 DOHC) Remover & installer, piston pin	B	
49 B012 0A0 (B6 EGI) Compressor, valve spring	A		49 0249 010A (B6 EGI) Remover & installer, valve guide	A	
49 B012 001 (B6 EGI) Pusher, valve seal	A		49 0636 100A (B6 EGI) Arm, valve spring lifter	A	
49 B012 005 (B6 DOHC) Remover & installer, valve guide	A		49 8134 040A (B6 EGI) Tool set, piston pin setting	A	
49 B012 006 (B6 DOHC) Pivot, valve spring lifter	A		49 S120 710 Holder, coupling flange	A	
49 B012 007 (B6 DOHC) Pusher, valve seal	A				

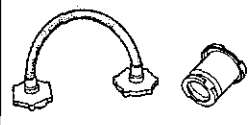
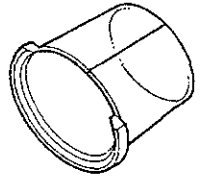
# 40 SPECIAL TOOLS

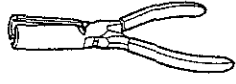
TOOL NUMBER & DESCRIPTION	PRIORITY	ILLUSTRATION
49 9200 145 Adapter, radiator cap tester	A	
49 B012 011 (B6 DOHC) HLA hole protector	B	

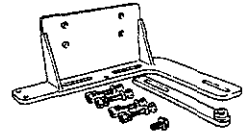
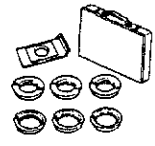
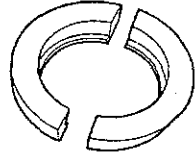

TOOL NUMBER & DESCRIPTION	PRIORITY	ILLUSTRATION
49 S120 170 Remover, valve seal	A	

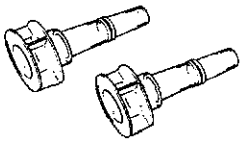
## CLUTCH & MANUAL TRANSAXLE GROUP

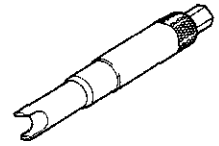
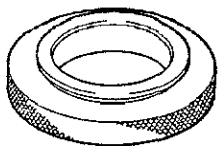
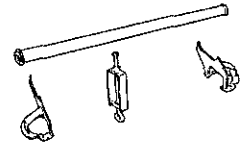
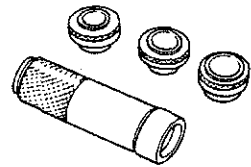
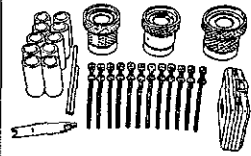
TOOL NUMBER & DESCRIPTION	PRIORITY	ILLUSTRATION
49 B017 0A0 (B6 EGI) Hanger, transaxle	A	
49 B017 1A0 (B6 EGI) Remover set, bearing	A	
49 B027 003 (4WD) Attachment M	A	
49 B017 5A0 (4WD) Support, engine	A	
49 B027 001 (4WD) Holder, differential side gear	A	

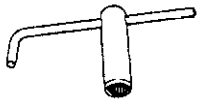
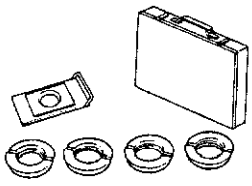
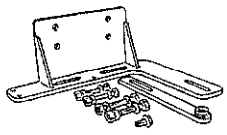
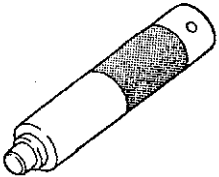
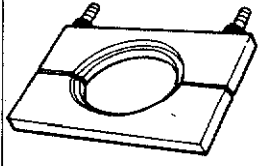
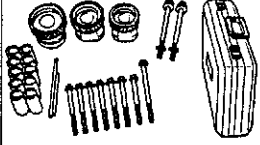
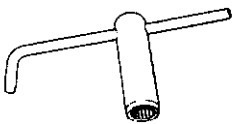
TOOL NUMBER & DESCRIPTION	PRIORITY	ILLUSTRATION
49 B027 002 (4WD) Adaptor, preload (Diff. side bearing)	A	
49 B027 004 (4WD) Measuring plate	A	
49 E301 025B (2WD) Support, engine	A	
49 F401 330B Installer set, bearing	A	
49 F401 380C (B6 EGI) Shim selector set	A	

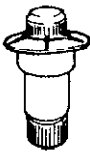
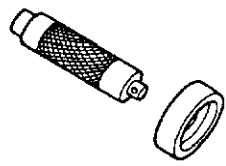
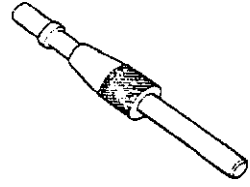
TOOL NUMBER & DESCRIPTION	PRIORITY	ILLUSTRATION
49 F401 440 (B6 EGI) Holder, primary shaft	A	
49 G017 1A0 (B6 DOHC) Remover set, bearing	A	
49 G019 0A0 (B6 DOHC) Hanger, transaxle	A	
49 B043 002 Installer, bearing	A	
49 G030 370 (B6 DOHC) Removing plate	A	
49 G030 380B (B6 DOHC) Shim selector set	A	
49 G030 440 (B6 DOHC) Holder primary shaft	A	

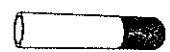
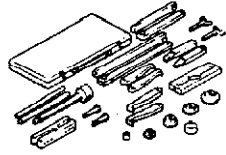
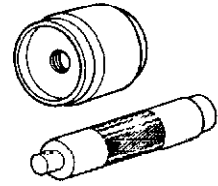
TOOL NUMBER & DESCRIPTION	PRIORITY	ILLUSTRATION
49 G030 455 (B6 DOHC) Holder differential side gear	A	
49 G030 795 (B6 DOHC) Installer, oil seal	A	
49 SE01 310 Centering tool, clutch disc	A	
49 H034 201 Support block	A	
49 0727 415 (4WD) Installer, bearing	A	
49 0839 425C Puller set, bearing	A	
49 B025 0A0 (4WD) Installer, dust seal	A	

## AUTOMATIC TRANSAXLE GROUP

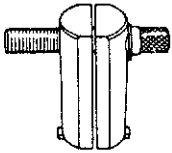
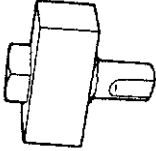
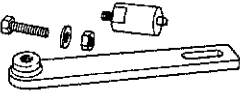
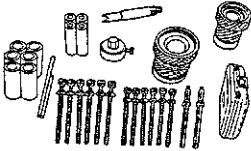
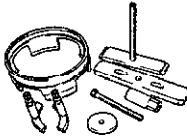
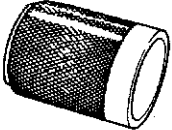
TOOL NUMBER & DESCRIPTION	PRIORITY	ILLUSTRATION
49 FT01 361 Remover, bearing	A	
49 FT01 439 Holder, idle gear shaft	A	
49 G019 0A2 Turbine shaft holder	A	
49 G019 0A5A Shim selector set	A	
49 G019 0A7 Compressor set, return spring	A	
49 G019 011 Bearing installer	A	

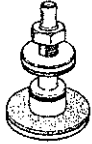
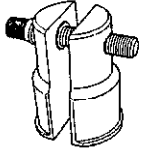
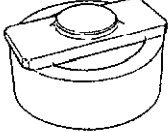
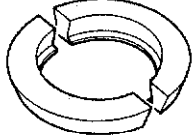
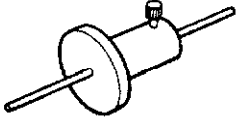
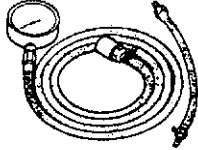
TOOL NUMBER & DESCRIPTION	PRIORITY	ILLUSTRATION
49 G019 012 Leak checker	A	
49 G019 013 Bearing remover	A	
49 G019 017 Oil seal installer	A	
49 G019 022 Attachment K	A	
49 G032 355 Adjust gauge	A	
49 0378 400A Gauge set, oil pressure	A	

## PROPELLER SHAFT & DIFFERENTIAL GROUP

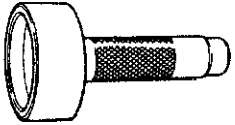
TOOL NUMBER & DESCRIPTION	PRIORITY	ILLUSTRATION
49 B001 795 (B6 EGI) Installer, oil seal	A	

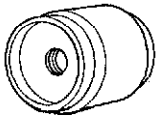
TOOL NUMBER & DESCRIPTION	PRIORITY	ILLUSTRATION
49 B025 001 (4WD) Body	A	

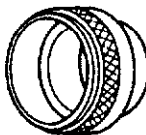
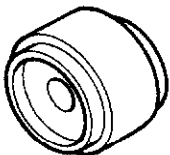
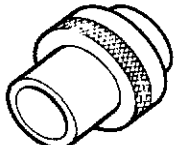
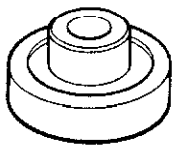
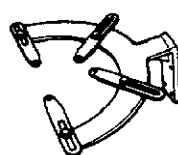
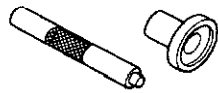

TOOL NUMBER & DESCRIPTION	PRIORITY	ILLUSTRATION
49 G030 338 (B6 DOHC) Attachment E	A	
49 H025 002 (4WD) installer, dust seal	A	
49 H025 003 (4WD) Installer, bearing	A	
49 H033 101 (4WD) Bearing remover	A	
49 M005 561 (4WD) Hanger, differential carrier	A	
49 M005 795 (4WD) Installer set, oil seal	A	

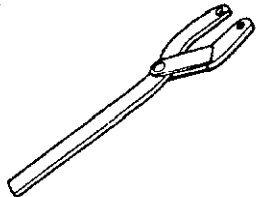
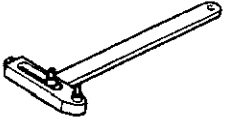
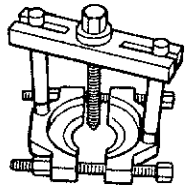
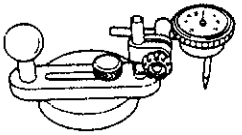
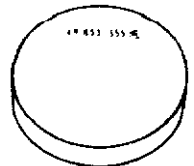
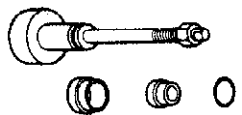
TOOL NUMBER & DESCRIPTION	PRIORITY	ILLUSTRATION
49 S120 710 Holder, coup- ling flange	A	
49 0259 720 (4WD) Wrench, differential side bearing adjust nut	A	
49 0710 520 (4WD) Puller bearing	A	
49 0727 570 (4WD) Gauge body, pinion height adjust	A	
49 8531 555 (4WD) Gauge block	A	
49 8531 565 (4WD) Pinion model	A	

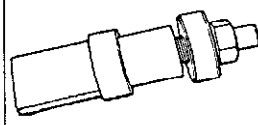

## BRAKE & AXLE GROUP

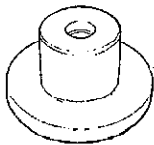
TOOL NUMBER & DESCRIPTION	PRIORITY	ILLUSTRATION
49 B001 727 Spacer, selec- tor (Front wheel hub)	A	

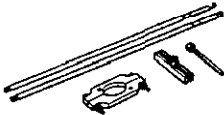
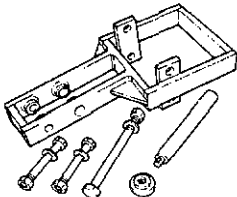
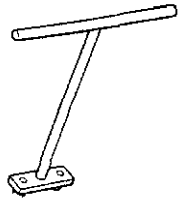
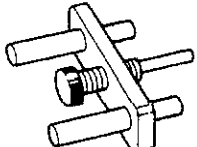

TOOL NUMBER & DESCRIPTION	PRIORITY	ILLUSTRATION
49 F026 102 Installer, bearing	A	

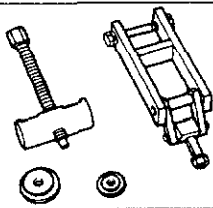
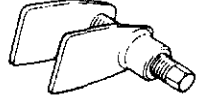

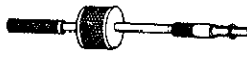
# 40 SPECIAL TOOLS

TOOL NUMBER & DESCRIPTION	PRIORITY	ILLUSTRATION
49 0187 520 Puller, rear axle shaft bearing	A	
49 B026 1A0 (4WD) Puller, wheel hub	A	
49 FA18 602 Wrench, disc brake piston	A	
49 F043 001 Adjust gauge	A	

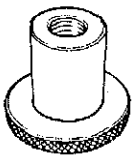
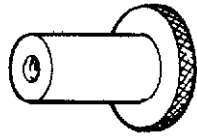

TOOL NUMBER & DESCRIPTION	PRIORITY	ILLUSTRATION
49 G030 725 (2WD) Puller, wheel hub (Front)	A	
49 0221 600C Expand tool, disc brake	A	
49 0259 770B Wrench, flare nut	A	
49 1285 071 Puller, bearing	A	

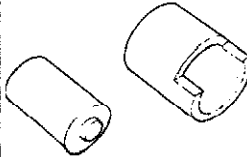
## STEERING & SUSPENSION GROUP

TOOL NUMBER & DESCRIPTION	PRIORITY	ILLUSTRATION
49 B001 605 (Front) Adaptor, caster, camber gauge	B	
49 B026 101 (Rear) Adaptor, camber gauge	A	
49 B032 3A0 Remover, oil seal	A	

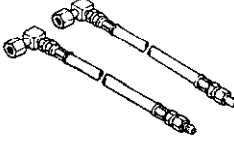
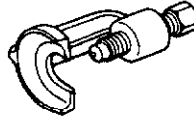
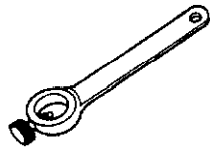
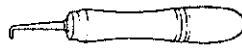
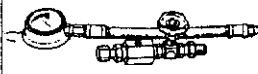
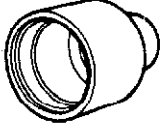
TOOL NUMBER & DESCRIPTION	PRIORITY	ILLUSTRATION
49 B032 302 Adaptor, power steering gauge	A	
49 B092 625A Puller & installer set, lower arm bush	A	
49 H001 585 Adjust wrench	A	

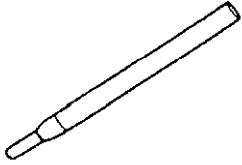
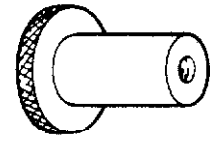
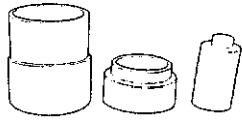
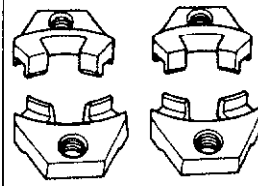
TOOL NUMBER & DESCRIPTION	PRIORITY	ILLUSTRATION
49 H002 671 Adaptor, power steering gauge	A	
49 0118 850C Puller, ball joint	B	
49 0180 510B Attachment, steering worm bearing preload measuring	B	
49 0208 710A Air out tool, boot	B	
49 1232 670A Gauge set, power steering	A	
49 8038 785 Boot installer, ball joint dust cover	A	

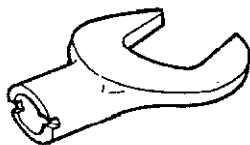

TOOL NUMBER & DESCRIPTION	PRIORITY	ILLUSTRATION
49 G030 595 Protector	A	
49 8531 605 (Rear) Adaptor, caster, camber gauge	B	
49 G030 625A Puller & installer set, lower arm bush	B	
49 0223 640B Arm, coil spring compressor	A	
49 0370 641 Screw, coil spring compressor	A	
49 B032 303 Wrench	A	

## TESTER & OTHER GROUP

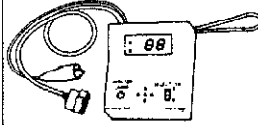
TOOL NUMBER & DESCRIPTION	PRIORITY	ILLUSTRATION
49 B092 953 Injector checker	A	

TOOL NUMBER & DESCRIPTION	PRIORITY	ILLUSTRATION
49 H018 9A1 Self-diagnosis checker	A	

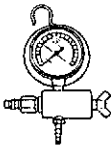
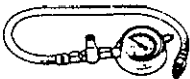
# 40 SPECIAL TOOLS

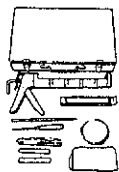
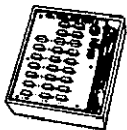
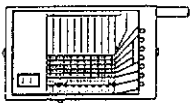
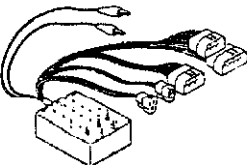
TOOL NUMBER & DESCRIPTION	PRIORITY	ILLUSTRATION
49 H080 740 (B6 DOHC) Pressure tester	A	
49 0187 280 Oil pressure gauge	B	
49 0259 866A Installing tool, seal pusher & blade	B	
49 0305 870A Tool set, win- dow (Bond type)	A	
49 0839 285 Checker, fuel thermometer	A	
49 9200 010 Auto cruise control checker	A	
49 9200 030B Logicon checker	A	

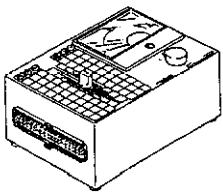
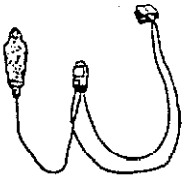
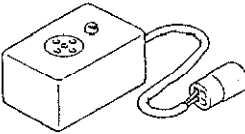
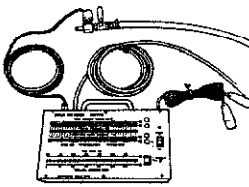
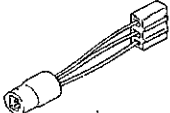
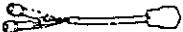
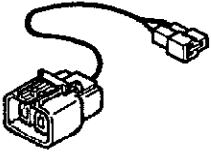
TOOL NUMBER & DESCRIPTION	PRIORITY	ILLUSTRATION
49 9200 162 Engine signal monitor	A	
49 U018 003 Adaptor harness	A	
49 9200 165 Tester, throttle sensor	A	
49 9200 750A Multi-pressure tester	A	
49 9200 166 Adaptor, throt- tle sensor	A	
49 F018 001 Checker lamp	A	
49 G018 001 Adaptor harness	A	

# 1988 Mazda 323 Wiring Diagram

## FOREWORD

This wiring diagram incorporates the wiring schematic for the basic vehicle and its available optional equipment. Actual vehicle wiring may vary slightly depending upon optional equipment and/or local specifications. All information contained in this booklet is based on the latest information available at the time of printing. Mazda Motor Corporation reserves the right to make changes without previous notice.

**Mazda Motor Corporation  
HIROSHIMA, JAPAN**

## SECTION INDEX

Name	Section
■ HOW TO USE THIS WIRING DIAGRAM ■ SYMBOL IN THIS WIRING DIAGRAM	0
■ PARTS INDEX	PI
■ ELECTRICAL WIRING SCHEMATIC	W
■ CHARGING SYSTEM ■ STARTING SYSTEM ■ STARTER INTERLOCK SYSTEM ■ INHIBITOR	A
■ COOLING FAN SYSTEM ■ IGNITION SYSTEM ■ ENGINE & FUEL CONTROL SYSTEM ■ 4AT CONTROL SYSTEM	B
■ METER & WARNING LIGHTS	C
■ FRONT WIPER & WASHER ■ REAR WIPER & WASHER	D
■ ILLUMINATION LIGHT CONTROL SYSTEM ■ FRONT MARKER LIGHTS ■ HEADLIGHTS ■ LICENSE LIGHTS ■ PARKING LIGHTS ■ TAIL LIGHTS ■ REAR MARKER LIGHTS	E
■ BACK-UP LIGHTS ■ TURN & HAZARD FLASHER LIGHTS ■ HORN ■ STOP LIGHTS	F
■ AIR CONDITIONER & HEATER	G
■ CIGARETTE LIGHTER	H
■ DIGITAL CLOCK ■ REAR WINDOW DEFROSTER	I
■ COURTESY LIGHTS ■ DOOR LOCK CYLINDER LIGHT ■ IGNITION KEY CYLINDER LIGHT ■ INTERIOR & SPOT LIGHTS ■ LUGGAGE COMPARTMENT LIGHT ■ SEAT BELT WARNING SYSTEM	J
■ POWER WINDOW	K
■ AUDIO SYSTEM	L
■ REMOTE CONTROL MIRROR	M
■ POWER DOOR LOCK	N
■ ADJUSTABLE SHOCK ABSORBER	O
■ CRUISE CONTROL SYSTEM	P
■ CENTER DIFFERENTIAL CONTROL SYSTEM	Q
■ COMMON CONNECTOR LIST	X
■ GROUND CIRCUIT	JC
■ JOINT BOX	JB
■ LIQUID CRYSTAL DISPLAY METER	—
■ PARTS LOCATION	PA

# Wiring Diagram

## SECTION INDEX

HOW TO USE THIS WIRING			
DIAGRAM .....	50:2	(O)	
SYMBOL IN THIS WIRING			
DIAGRAM .....	50:5	(O)	
PARTS INDEX .....	50:6	(PI)	
ELECTRICAL WIRING			
SCHEMATIC .....	50:8	(W)	
<b>Except 4WD</b>			
CHARGING SYSTEM .....	50:10	(A-1)	
STARTING SYSTEM .....	50:10	(A-1)	
STARTER INTERLOCK SYSTEM			
(For M/T) .....	50:10	(A-1)	
INHIBITOR (For 4AT) .....	50:10	(A-1)	
<b>For 4WD</b>			
CHARGING SYSTEM .....	50:12	(A-2)	
STARTING SYSTEM .....	50:12	(A-2)	
STARTER INTERLOCK SYSTEM ...	50:12	(A-2)	
<b>For Turbo</b>			
COOLING FAN SYSTEM .....	50:14	(B-1 a)	
IGNITION SYSTEM .....	50:14	(B-1 a)	
ENGINE & FUEL CONTROL			
SYSTEM .....	50:14	(B-1 a)	
ENGINE CONTROL SYSTEM ...	50:16	(B-1 b)	
<b>For Turbo with 4WD</b>			
COOLING FAN SYSTEM .....	50:18	(B-2a)	
IGNITION SYSTEM .....	50:18	(B-2a)	
ENGINE & FUEL CONTROL			
SYSTEM .....	50:18	(B-2a)	
ENGINE CONTROL SYSTEM ...	50:20	(B-2b)	
<b>For Non-Turbo</b>			
COOLING FAN SYSTEM .....	50:22	(B-3a)	
IGNITION SYSTEM .....	50:22	(B-3a)	
ENGINE & FUEL CONTROL			
SYSTEM .....	50:22	(B-3a)	
4AT CONTROL SYSTEM .....	50:22	(B-3a)	
ENGINE CONTROL SYSTEM ...	50:24	(B-3b)	
METERS & WARNING LIGHTS ...	50:26	(C)	
FRONT WIPER & WASHER .....	50:28	(D)	
REAR WIPER & WASHER			
(3&5 Door) .....	50:28	(D)	
ILLUMINATION LIGHT CONTROL			
SYSTEM .....	50:30	(E-a)	
FRONT MARKER LIGHTS .....	50:32	(E-b)	
HEADLIGHTS .....	50:32	(E-b)	
LICENSE LIGHTS .....	50:32	(E-b)	
PARKING LIGHTS .....	50:32	(E-b)	
TAIL LIGHTS .....	50:32	(E-b)	
REAR MARKER LIGHTS .....	50:32	(E-b)	
BACK-UP LIGHTS .....	50:34	(F-a)	
TURN & HAZARD FLASHER			
LIGHTS .....	50:34	(F-a)	
HORN .....	50:36	(F-b)	
STOP LIGHTS .....	50:36	(F-b)	
AIR CONDITIONER & HEATER ...	50:38	(G)	
CIGARETTE LIGHTER .....	50:40	(H)	
DIGITAL CLOCK .....	50:42	(I)	
REAR WINDOW DEFROSTER .....	50:42	(I)	
COURTESY LIGHTS .....	50:44	(J)	
DOOR LOCK CYLINDER LIGHT ...	50:44	(J)	
IGNITION KEY CYLINDER LIGHT ...	50:44	(J)	
INTERIOR & SPOT LIGHTS .....	50:44	(J)	
LUGGAGE COMPARTMENT			
LIGHT .....	50:44	(J)	
SEAT BELT WARNING SYSTEM ...	50:44	(J)	
POWER WINDOW .....	50:46	(K)	
AUDIO SYSTEM .....	50:48	(L)	
REMOTE CONTROL MIRROR ...	50:50	(M)	
POWER DOOR LOCK .....	50:52	(N)	
ADJUSTABLE SHOCK			
ABSORBER .....	50:54	(O)	
CRUISE CONTROL SYSTEM .....	50:56	(P)	
CENTER DIF. CONTROL SYSTEM ...	50:60	(Q)	
COMMON CONNECTOR LIST ...	50:61	(X)	
GROUND CIRCUIT .....	50:62	(JC)	
INTER CONNECTING DIAGRAM OF			
JOINT BOX .....	50:62	(JB)	
JB CONNECTOR LOCATION .....	50:63	(JB)	
JOINT BOX .....	50:63	(JB)	
LIQUID CRYSTAL DISPLAY			
(ELECTRONIC) METER .....	50:64	(PA)	
PART LOCATION .....	50:65	(PA)	

## HOW TO USE THIS WIRING DIAGRAM

The complete electrical system is divided into charging system, ignition system, etc.

Each system is shown on both right and left pages as described below.

When reading the wiring diagram, following should be noted:

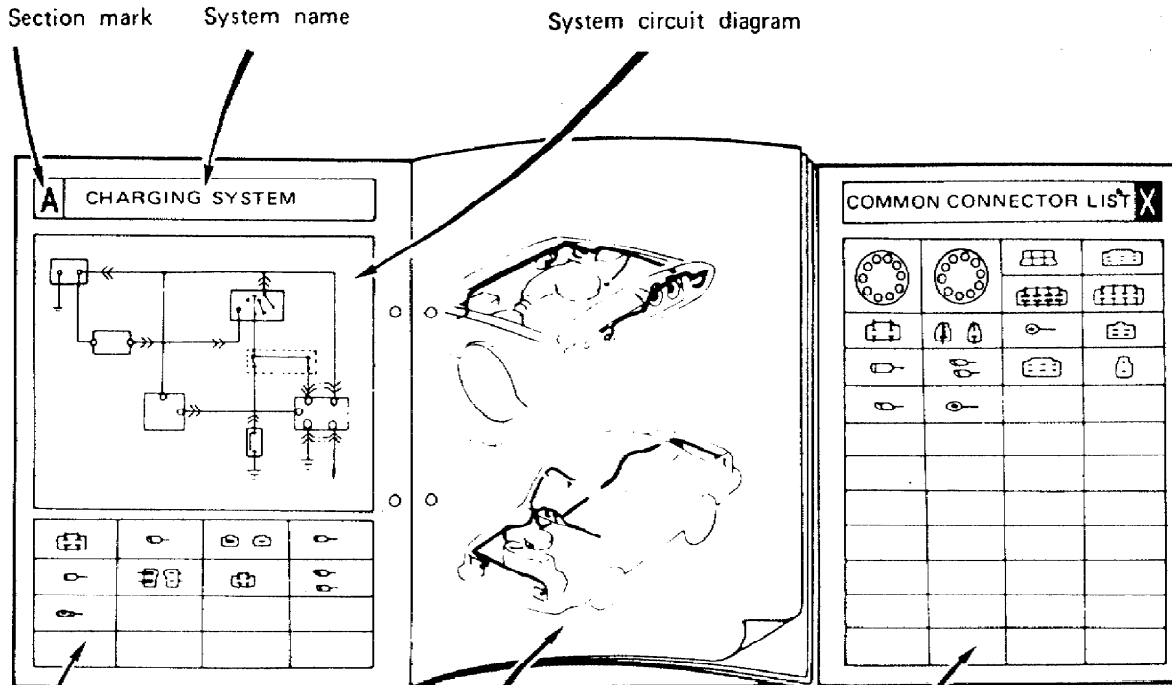

- Connector diagram identifies the exclusive applicable connectors for the circuit.
- Right page illustrates the actual location of each connector and the routing diagram of the harness.
- The last page, "Section X", illustrates common connectors related to each system.

### CONNECTOR

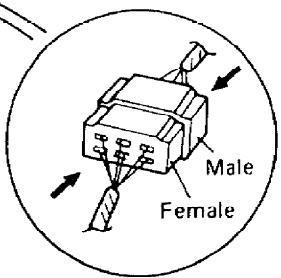
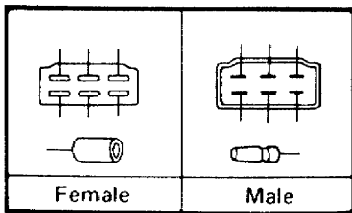

Way to look at Connector

**WIRING COLOR CODE**

Wiring color code is indicated with alphabetical letter/s. The first letter indicates the basic color of the wire, and second letter (if any) indicates that the color of the stripe.

CODE	COLOR	CODE	COLOR
B	Black	Lg	Light green
Br	Brown	O	Orange
G	Green	R	Red
L	Blue	Y	Yellow
Lb	Light blue	W	White
LO	Blue Orange	WR	White Red
LgB	Light green Black		

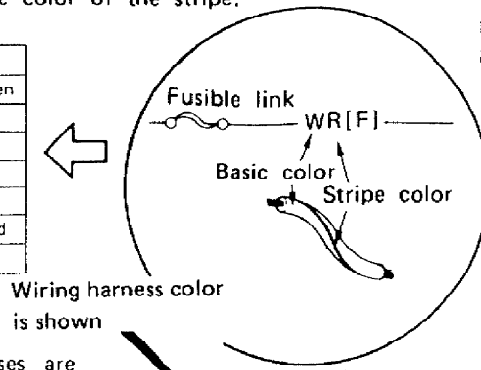

Direction of current is shown by the arrow

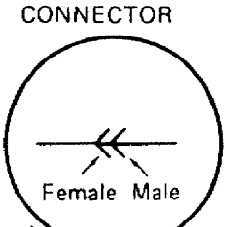
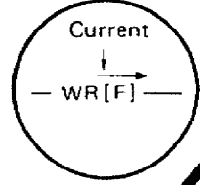

The same fusible link and fuses are indicated on each page.

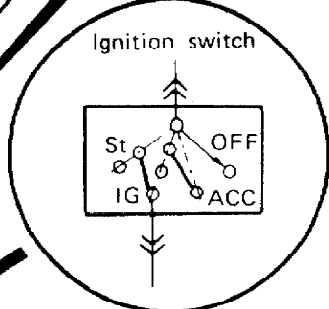
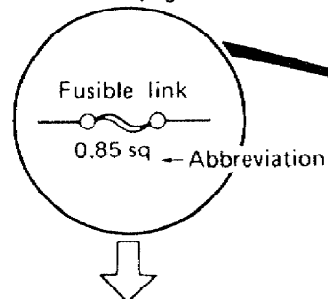

Circuit is shown with the ignition switch off.

**ABBREVIATIONS USED IN THIS BOOKLET**

Abbr.	Term	Abbr.	Term
St	Start	A	Ampere
IG	Ignition	W	Watt
ACC	Accessory	R	Resistance
AS	Auto stop	Tr	Transistor
INT	Intermittent	M	Motor
Lo	Low	SW	Switch
Mi	Middle	Sq	Square per millimeter
Hi	High	A/T	Automatic transmission
R.H.	Right hand	M/T	Manual transmission
L.H.	Left hand	NO	Normal opened
F.R.	Front right	NC	Normal closed
F.L.	Front left	MH	Middle high
R.R.	Rear right		
R.L.	Rear left		
V	Volt		

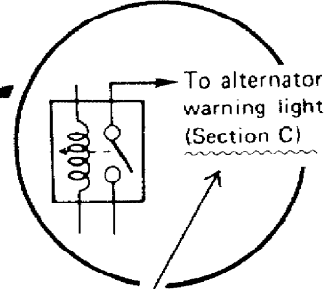
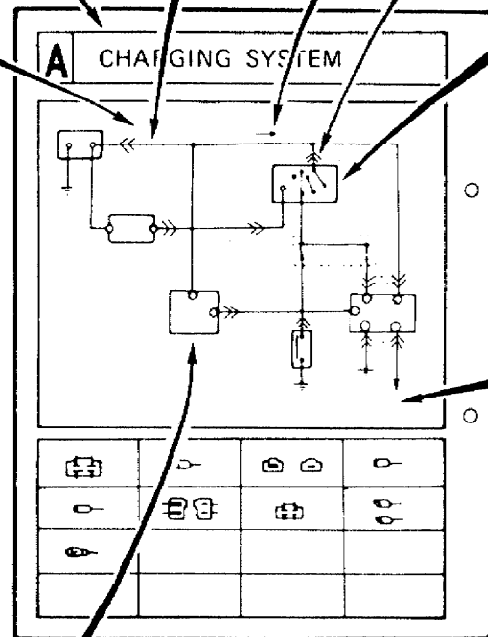

Legend in the parenthesis ( ) indicates the reference section.

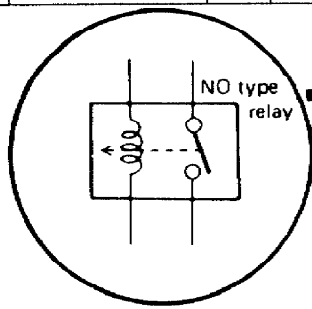

The relays and switches are identified as NC (normal closed), or NO (normal opened), to indicate their normal position when they are not in operation.

	Relay		Switch	
	NO type relay	NC type relay	NO switch	NC switch
Not in operation				
In operation				



# 50-0 HOW TO USE THIS WIRING DIAGRAM

## HARNESS SYMBOLS

Each harness is distinguished by a symbol to indicate to which harness belong a wiring and connector in circuit diagrams and connector charts.

DESCRIPTION OF HARNESS	COLOR	SYMBOL	DESCRIPTION OF HARNESS	SYMBOL
Front harness	—	[F]	No. 1 Door harness	[Dr1]
Engine harness	—	[E]	No. 2 Door harness	[Dr2]
Instrument panel harness	—	[I]	No. 3 Door harness	[Dr3]
Rear harness	—	[R]	No. 4 Door harness	[Dr4]
No. 2 Rear harness		[R2]	Audio harness	[Au]
Emission harness		[EM]	Air Con. harness	[AC]
Interior light harness		[In]		
Floor harness		[Fr]		

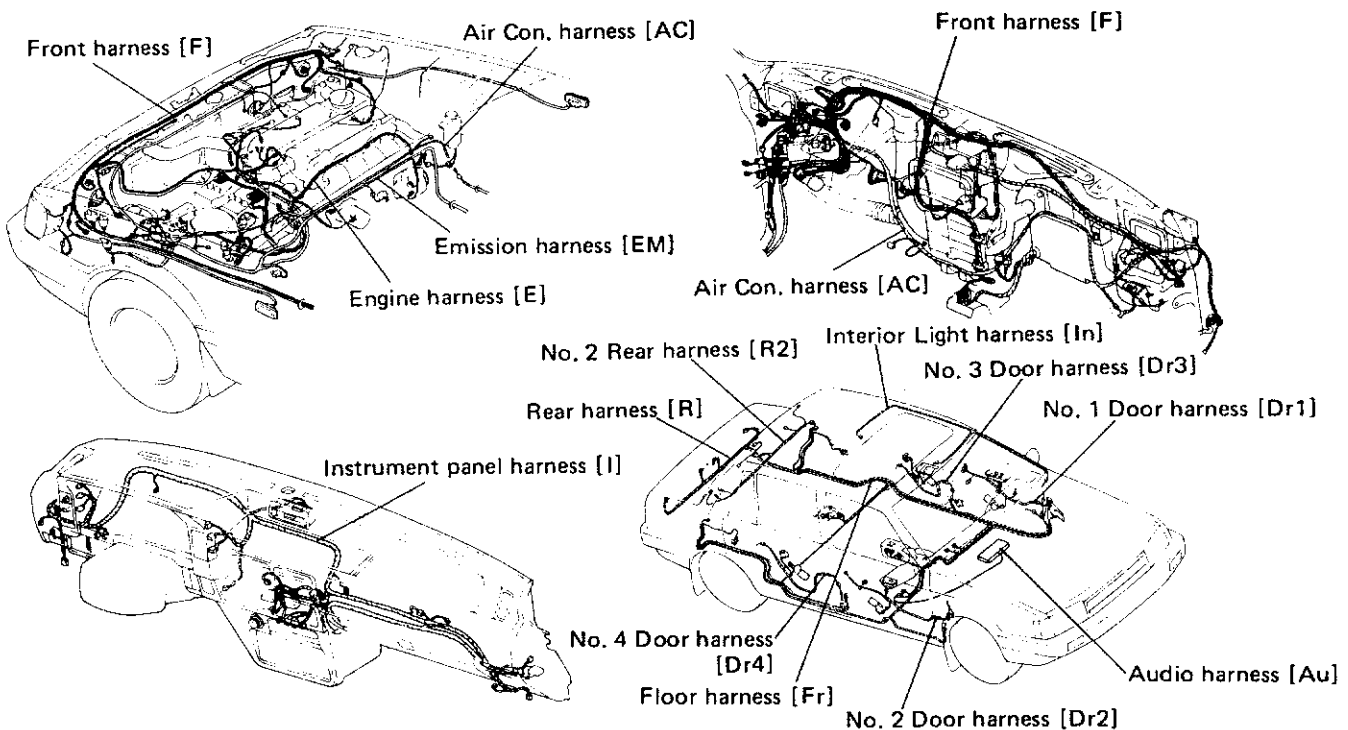

### EXAMPLE OF CIRCUIT DIAGRAM

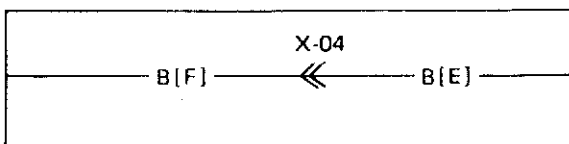

- It is seen from the above that the male-side black line of the X-04 shows the engine harness and the female-side black line shows the front harness.
- It is seen from the above that the X-04 connector is a connector connecting the engine and the front.

### EXAMPLE OF CONNECTOR

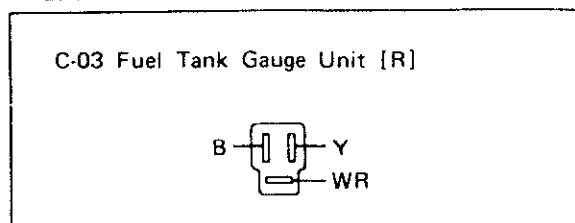



- It is seen from the above that this connector (C-03) is on the Rear harness.





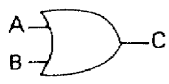
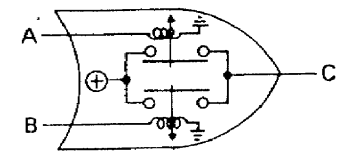
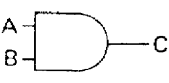
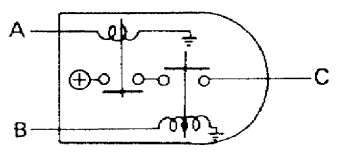
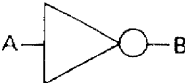
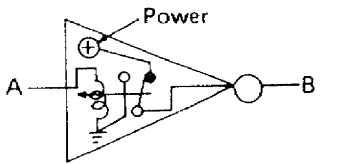

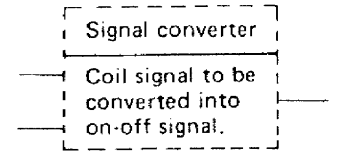



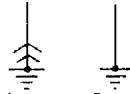
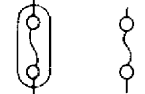

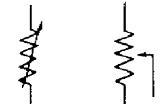

**SYMBOLS IN THIS WIRING DIAGRAM**

**LOGICAL SYMBOLS**

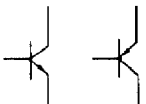
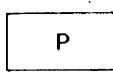
The logical symbols are of four kinds: OR, AND, INV. (Inverter), PROCESS.  
The circuit operation can be easily read by understanding these symbols.

<p>OR</p> 	<p>In case of input to either A or B, an output comes out from C. When A and B are off (0V), C is off (0V). When either A or B is on (12V), C is on (12V). This can be simply shown in the relay circuit on the right-hand side.</p>	
<p>AND</p> 	<p>In case of input to both A and B, an output comes out from C. When A and B are on (12V), C is on (12V). When either A or B is off (0V), C is off (0V). This can be simply shown in the relay circuit on the right-hand side.</p>	
<p>INV. (Inverter)</p> 	<p>In case of input to A, B is grounded. When A is off (0V), B is on (12V). When A is on (12V), B is off (0V). This can be simply shown in the relay circuit on the right-hand side.</p>	
	<p>PROCESS makes a simplified representation of complicated functions of the circuit. Functions mainly used: 1. Detection of signals 2. Conversion of signals The process of the full transistor ignition control unit is as shown in the right-hand figure.</p>	

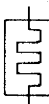
**GRAPHIC SYMBOLS**

				
Battery	Ground	Fuse	Fusible link	Motor
				
Coil solenoid	Resistance	Variabel resistance	Thermister	Diode
				
Condenser	Transistor	Pump	Lamp	Horn
				
Speaker	Cigar lighter	Heater	Illuminated Diode	Zener Diode

PI

PARTS INDEX

Parts	Section	Parts	Section
Ⓐ Adjustable Damper Actuator .....	O	<b>Combination Switch</b>	
Actuator Solenoid Valve .....	P-1, 2	License Light L.H., R.H. ....	E-b
Adjustable Damper Actuator .....	O	Meter Illumi. ....	C, E-a
Adjustable Damper Switch .....	O	Parking Light L.H., R.H. ....	E-b
A/C. Relay No. 1, No. 2 .....	G	Tail Light L.H., R.H. ....	E-b
A/C. Switch .....	G	Radio Illumi. ....	E-a, L
Air Flow Meter .....	B-1b, 2b, 3b	Rear Marker Light L.H., R.H. ....	E-b
Alternator With Regulator .....	A-1, 2	Rear Turn Light L.H., R.H. ....	F-a
AM, FM Electronic Tuner .....	L	Condenser .....	B-1a, 2a, 3a
Atmospheric Pressure Sensor .....	B-1b, 2b, 3a	Condenser Fan Motor .....	G
		Cooling Fan Motor .....	B-1a, 2a, 3a
		Cooling Fan Relay .....	B-1a, 2a, 3a
		Courtesy Light L.H., R.H. ....	J
		Cruise Control Unit .....	P
Ⓑ Back-Up Light .....	F-a	Ⓓ Din Cord .....	L
Back-Up Light Switch .....	F-a	Diode .....	B-3a
Battery .....	A ~ P	Digital Clock .....	I
Blower Motor .....	G	Distributor .....	B-1a, 2a, 3a
Blower Motor Control Switch .....	G	Door Handle Switch .....	J
Brake Fluid Level Switch .....	C	Door Lock Cylinder Light .....	J
Buckle Switch .....	J	Door Switch .....	J
Buzzer .....	C, J		
		Ⓔ Electrical Load Control Unit .....	B-1b, 2b, 3b
		Engine Control Unit .....	B-1a, 1b, 2a, 2b, 3a, 3b
		Entry Illumi. Timer .....	J
Ⓒ Cassette Deck .....	L	Ⓕ Front Speaker L.H., R.H. ....	L
Check Connector .....	B-b	Front Wiper & Washer Motor .....	D
Check Relay .....	C	Fuel Meter .....	C
Cigarette Lighter .....	H	Fuel Pump .....	B-1a, 2a, 3a
Circuit Opening Relay .....	B-1a, 2a, 3a	Fuel Pump Control Unit .....	B-2a
<b>Cluster Switch L.H.</b>		Fuel Tank Unit .....	B-2a
Rear Window Defroster Switch .....	I		
Rear Wiper & Washer Switch .....	D	Ⓖ High Mounted Stop Light .....	E-b
<b>Cluster Switch R.H.</b>		Horn L.H., R.H. ....	F-b
Cruise Control Main Switch .....	P	Horn Relay .....	F-b
Panel Light Control Switch .....	E-a		
Clutch Switch .....	B-1b, 2b, 3b, P	Ⓗ Igniter .....	B-1a, 2a, 3a
<b>Combination Switch</b>		Ignition Coil .....	B-1a, 2a, 3a
Adjustable Damper Illumi. ....	E-a, O	Ignition Key Illumi. ....	J
A/C. Switch Illumi. ....	E-a, G-a, G-b	Ignition Key Reminder Switch .....	J
A/T Select Illumi. ....	E-a	Ignition Relay .....	G, JB
Center Dif-Lock Illumi. ....	E-a	Ignition Switch .....	A ~ P
Cigarette lighter Illumi. ....	E-a	<b>Indicator &amp; Warning Lights</b>	
Cluster Illumi. L.H., R.H. ....	E-a	Brake .....	C
Cruise Main Switch Illumi. ....	E-a, P	Charge (Alternator) .....	C
Flasher Unit .....	F-a	Fuel .....	C
Front Marker Light L.H., R.H. ....	E-b	High Beam .....	C
Front Turn Light L.H., R.H. ....	F-a	Oil Pressure .....	C
Front Washer Switch .....	D	Rear Window Defroster .....	C
Front Wiper Switch .....	D	Seat Belt .....	C
Headlight L.H., R.H. ....	E-b	Stop Light .....	C
Heater Illumi. ....	E-a		
Horn Switch .....	F-b		

## PARTS INDEX

PI

Parts	Section	Parts	Section
Turn L.H., R.H. ....	C	Rear Washer Motor .....	D
Washer Level .....	C	Rear Wiper Motor .....	D
Inhibitor Switch .....	A-1	Rear Window Defroster .....	I
Injector No. 1, No. 2, No. 3, No. 4 .....	B-1a, 2a, 3a	Refrigerant Pressure Switch (With Air Con.) .....	G
Interior & Spot Light .....	J	Remote Control Mirror Motor .....	M
① Joint Connector .....	B-1a, 2a, 3a	Remote Control Mirror Switch .....	M
② Kick-down Switch (For 4AT) .....	B-3a	Resistor .....	G
Knock Controller .....	B-1a, 2a	③ Seat Belt Timer & Buzzer .....	J
Knock Sensor .....	B-1a, 2a	Sliding Sunroof .....	H
④ Luggage Compartment Light .....	J	Sliding Sunroof Relay No. 1, No. 2 .....	H
Luggage Compartment Light Switch .....	J	Sliding Sunroof Switch .....	H
⑤ Main Fuse .....	A ~ P	Speed Sensor .....	C, P
Main Relay .....	B-1a, 2a, 3a,	<b>Solenoid Valve</b>	
Magnet Clutch (A/C) .....	G	For No.1 Purge Control Valve .....	B-1 b, 2b, 3a
⑥ Neutral Switch .....	B-1b, 2b, 3b	For Vacuum Switch Valve .....	B-1 b, 2b, 3a
⑦ O/D Switch .....	B-3a	I.S.C. ....	B-1b, 2b, 3b
Oil Pressure Switch .....	C	Kick Down .....	B-3a
Oscillator .....	C	P.R.C. ....	B-1b, 2b, 3b
Oxygen Sensor .....	B-1b, 2b, 3b	O/D .....	B-3a
⑧ Parking Brake Switch .....	C	Starter Interlock Sw .....	A-1, 2
Power Door Lock Motor .....	N	Starting Motor .....	A-1, 2
Power Door Lock Relay .....	N	Stop Light .....	F-b
Power Door Lock Switch .....	N	Stop Light Checker .....	F-b
Power Steering Pressure Switch .....	B-1b, 2b, 3b	Stop Light Switch .....	F-b
Power Steering Solenoid Valve .....	B-a, B-b	Stop Switch .....	F-b, P
Power Window Motor .....	K	⑨ Tachometer .....	C
Power Window Switch .....	K	Test Connector .....	B-1b, 2b, 3b
Pressure Sw .....	B-1b, 2b	Throttle Sensor .....	B-1b, 2b, 3b
⑩ Rear Amp. ....	L	Transfer Pump .....	B-2a
Rear Speaker L.H., R.H. ....	L	⑪ Washer Fluid Low Level Switch .....	C
Rear Speaker Cord .....	L	Water Thermo Switch .....	B-1a, 1b, 2a, 2b, 3a, 3b, C
		Water Thermo Sensor .....	B-1b, 2b, 3b

# W ELECTRICAL WIRING SCHEMATIC

——— Current From Battery  
 - - - - - Current From IG Terminal of Ignition Switch  
 - - - - - Current From ACC Terminal of Ignition Switch  
 ——— Others

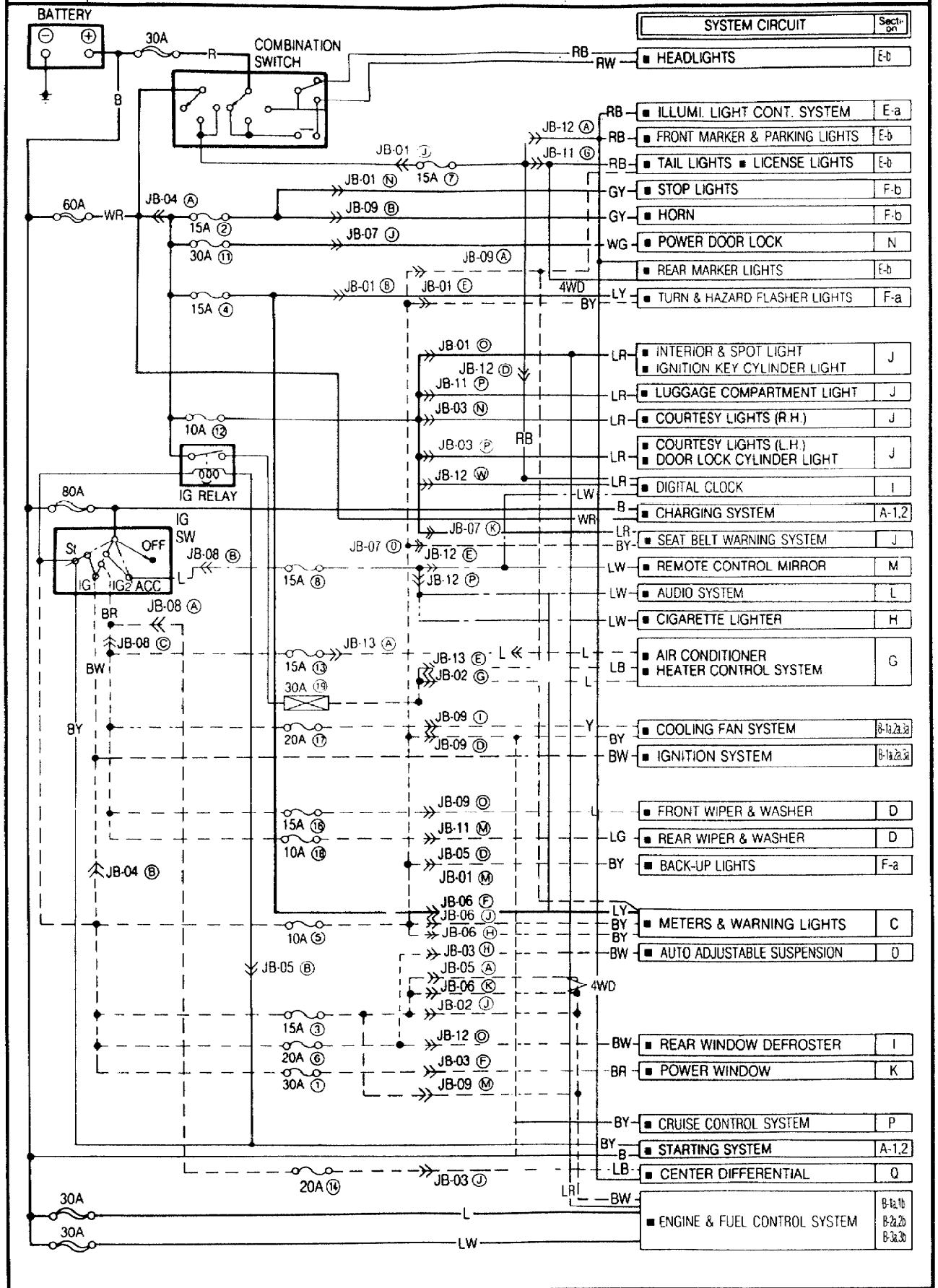

**A-1**

Except 4WD

- CHARGING SYSTEM ■ STARTING SYSTEM
- STARTER INTERLOCK SYSTEM (M/T) ■ INHIBITOR (4AT)

Note:  
\* ... Not Used

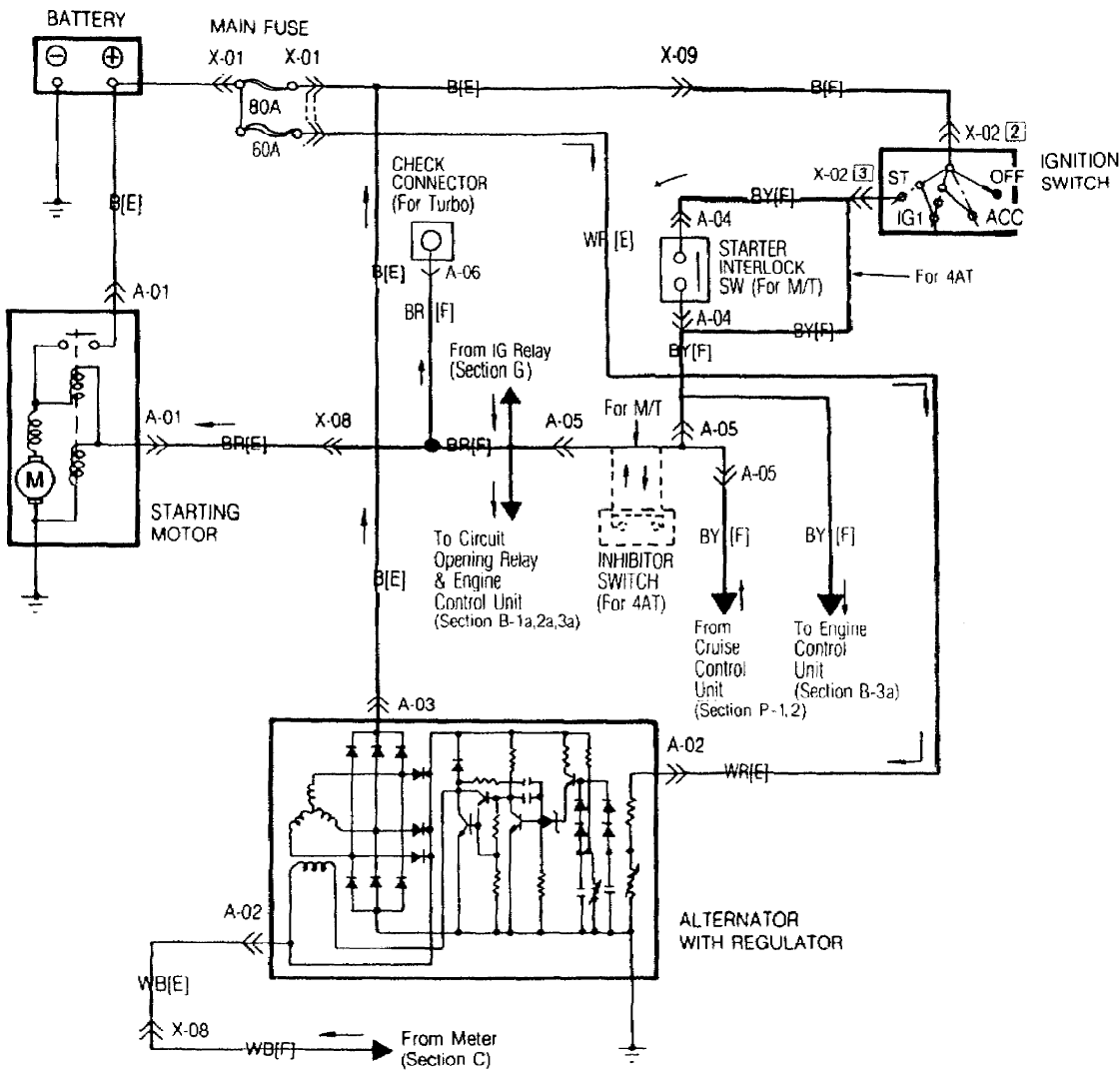

A-01 Starting Motor [E]



A-02 Alternator With Regulator [E]



A-03 Alternator With Regulator [E]



A-04 Starter Interlock Sw [F]

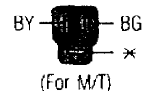

A-05 Inhibitor Sw [F]



A-06 Check Connector [F]



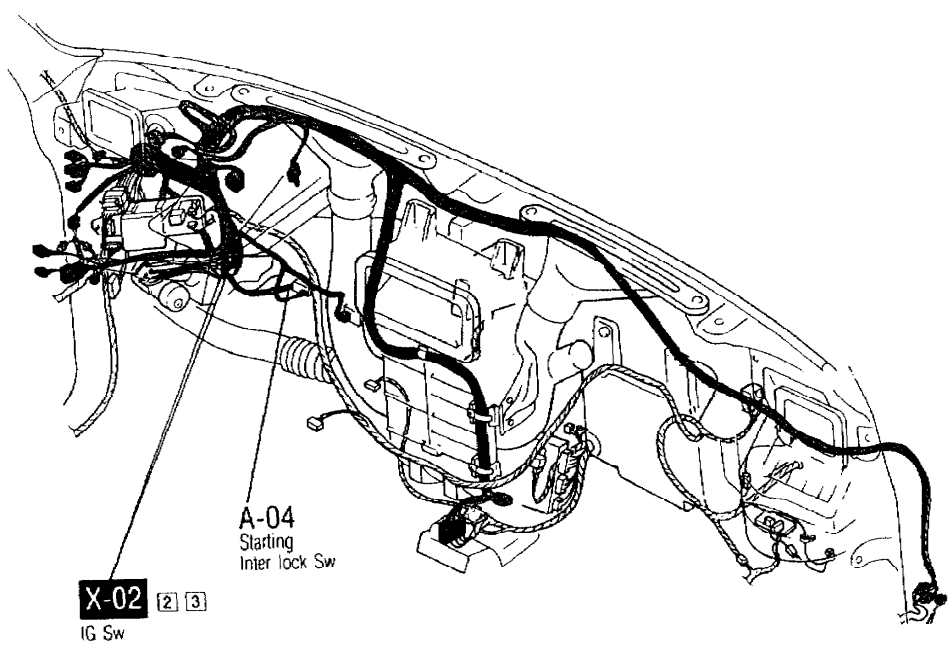
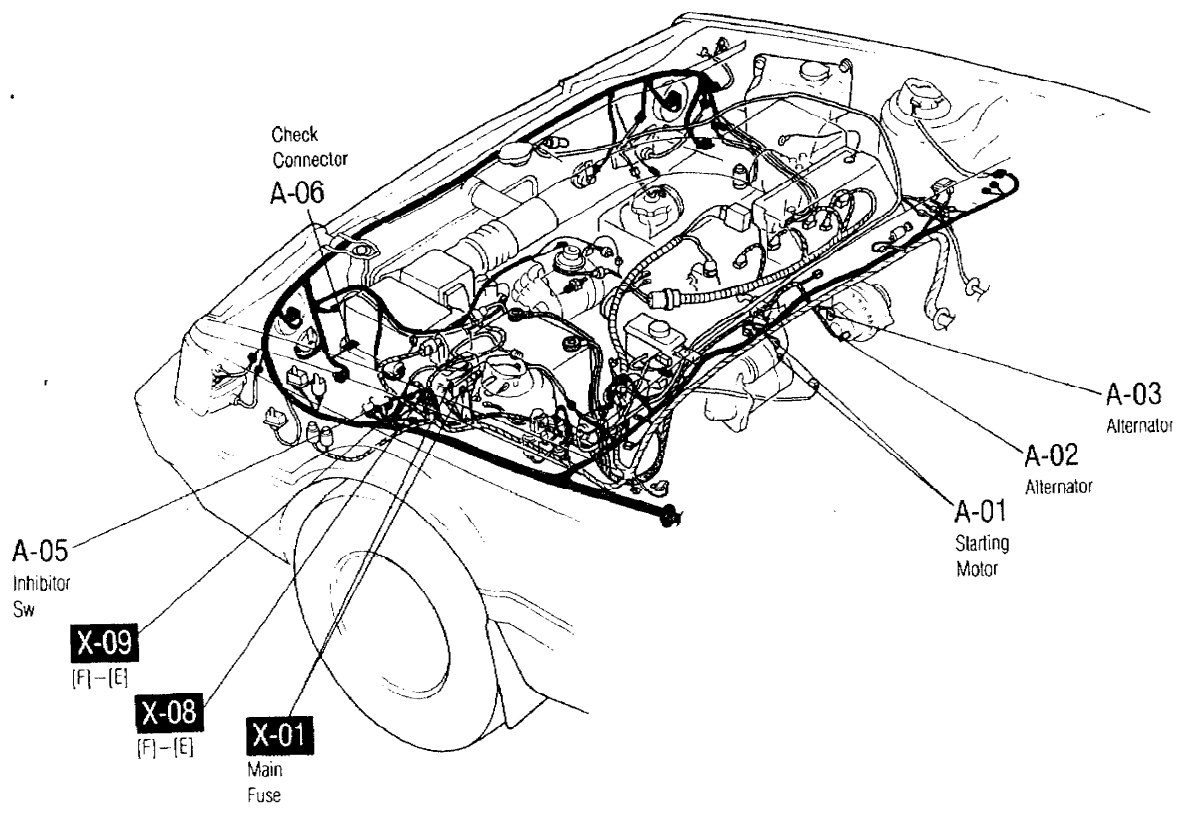





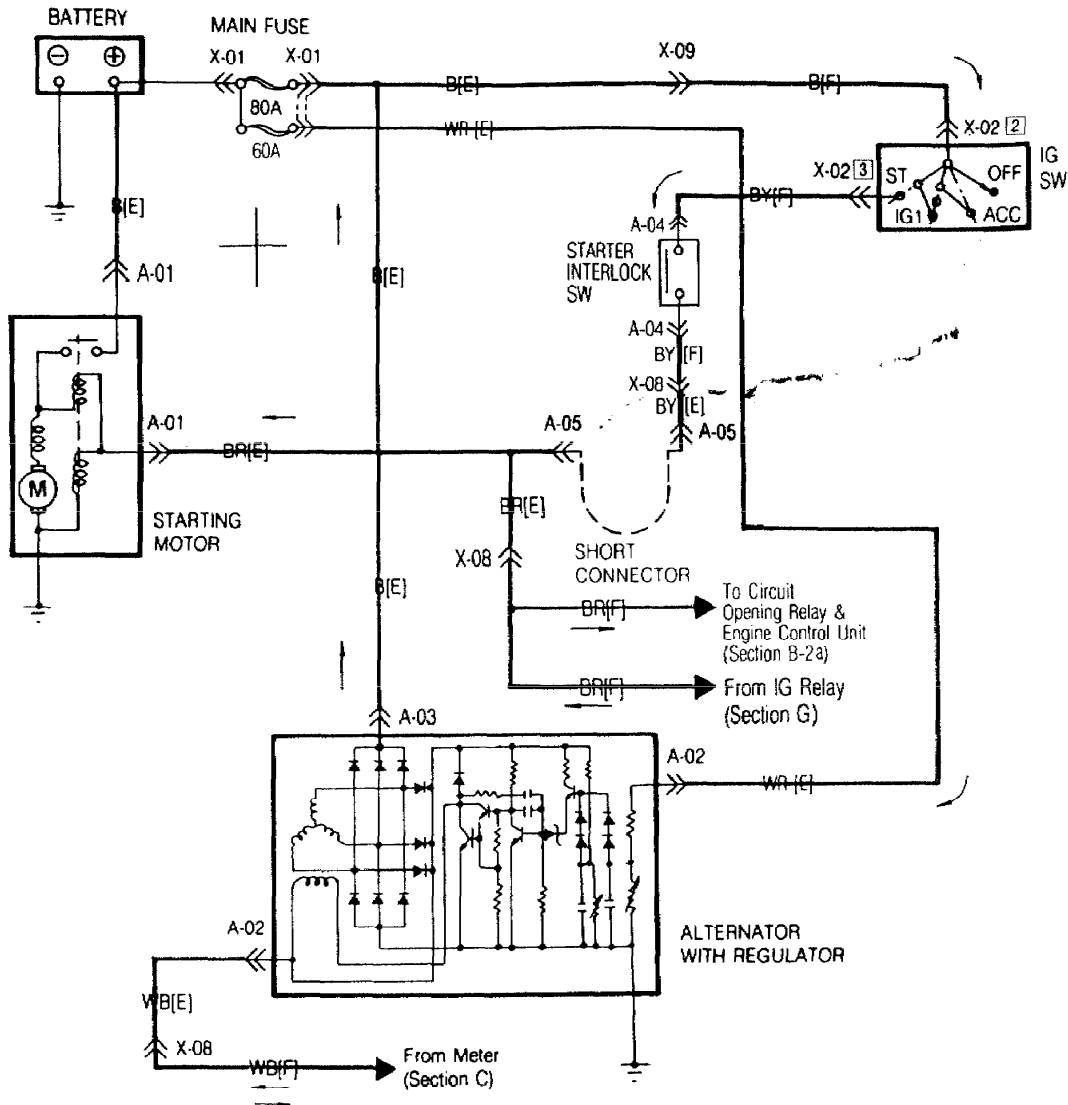

**A-2**

**For 4WD**  
**■ CHARGING SYSTEM ■ STARTING SYSTEM**  
**■ STARTER INTERLOCK SYSTEM**

Note:  
 \* ... Not Used



<p>A-01 Starting Motor [E]</p>  <p>BR</p>	<p>A-02 Alternator With Regulator [E]</p>  <p>WR WB</p>	<p>A-03 Alternator With Regulator [E]</p>  <p>B</p>	<p>A-04 Starter Interlock Sw [F]</p>  <p>BY — BG *</p>
<p>A-05 Back-Up Light Sw [E]</p>  <p>BY BY [E] RW BR</p>	<p>Short Connector</p> 		



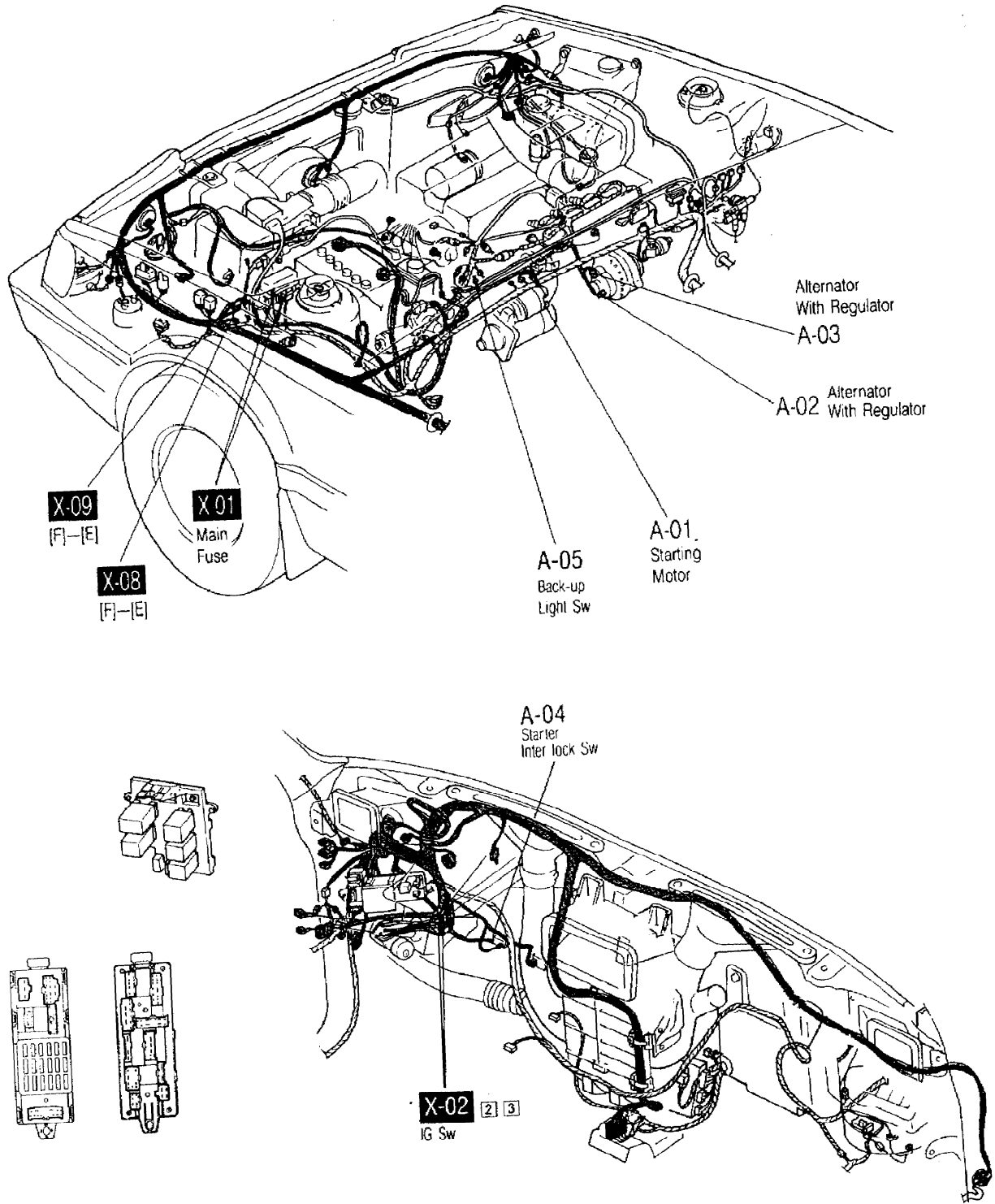

B-1a

For Turbo ■ IGNITION SYSTEM ■ ENGINE & FUEL CONTROL SYSTEM ■ COOLING FAN SYSTEM

\* ... Not Used

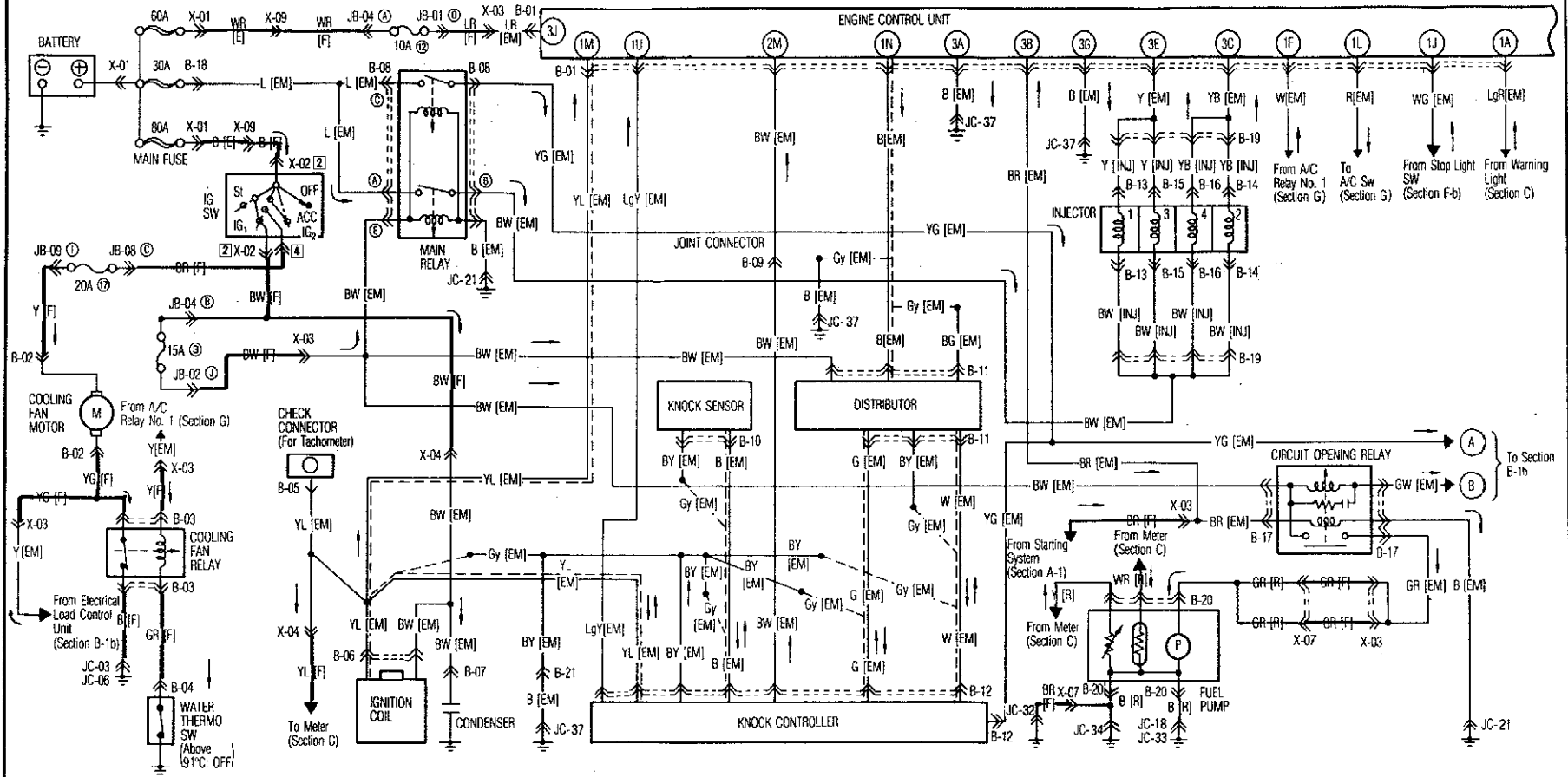

<p>B-01 Engine Control Unit [EM]</p>	<p>B-02 Cooling Fan Motor [F]</p>	<p>B-03 Cooling Fan Relay [F]</p>	<p>B-04 Water Thermo Sw [F]</p>	<p>B-05 Check Connector [EM]</p>	<p>B-06 IG Coil [EM]</p>	<p>B-07 Condenser [EM]</p>	<p>B-08 Main Relay [EM]</p>	<p>B-09 Joint Connector [EM]</p>	<p>B-10 Knock Sensor [EM]</p>	<p>B-11 Distributor [EM]</p>	<p>B-12 Knock Controller [EM]</p>
<p>B-13 Injector No.1 [INJ]</p>	<p>B-14 Injector No.2 [INJ]</p>	<p>B-15 Injector No.3 [INJ]</p>	<p>B-16 Injector No.4 [INJ]</p>	<p>B-17 Circuit Opening Relay [EM]</p>	<p>B-18 Main Fuse [EM]</p>	<p>B-19 Connector Between Emission (EM) and Injector (INJ) Harness</p>					
<p>B-20 Fuel Pump [R]</p>	<p>B-21 Joint Connector [EM]</p>										

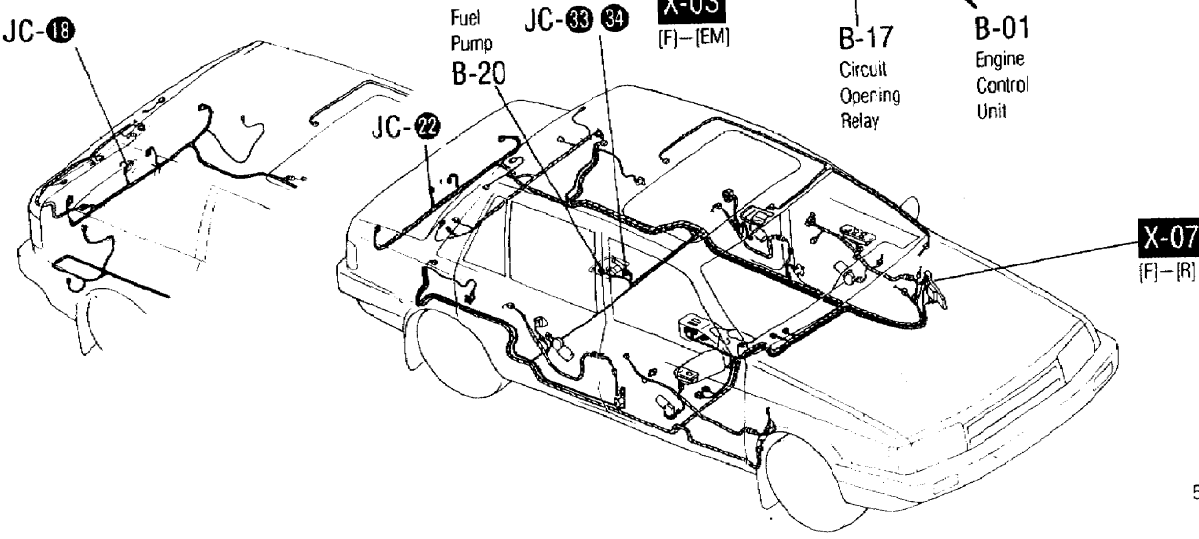
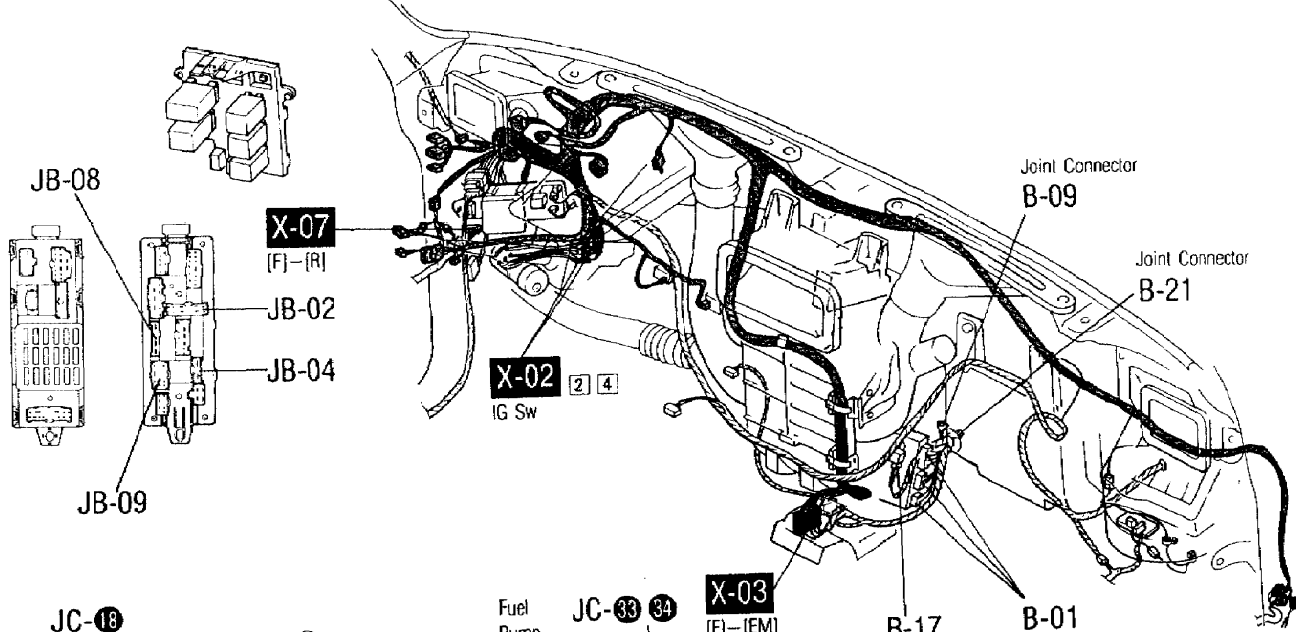
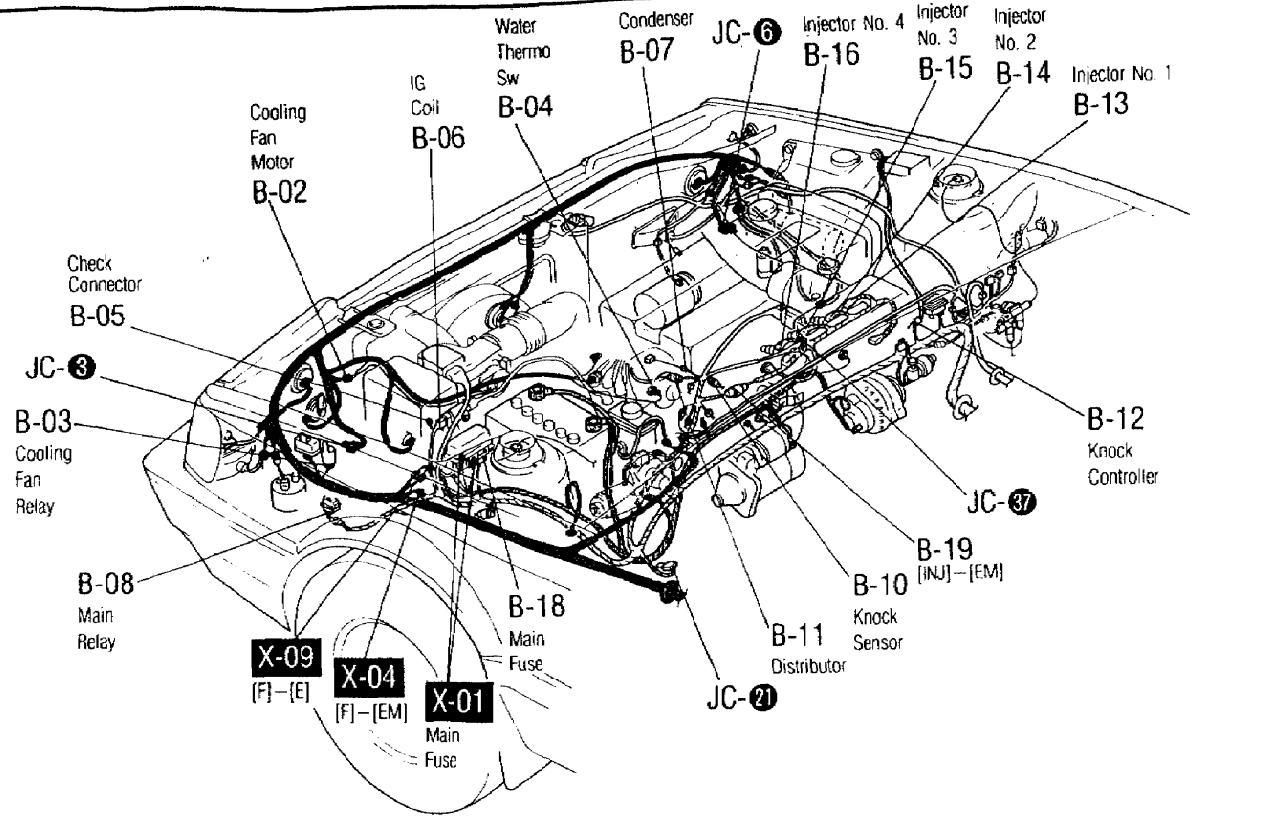

# B-1b For Turbo ■ ENGINE & FUEL CONTROL SYSTEM

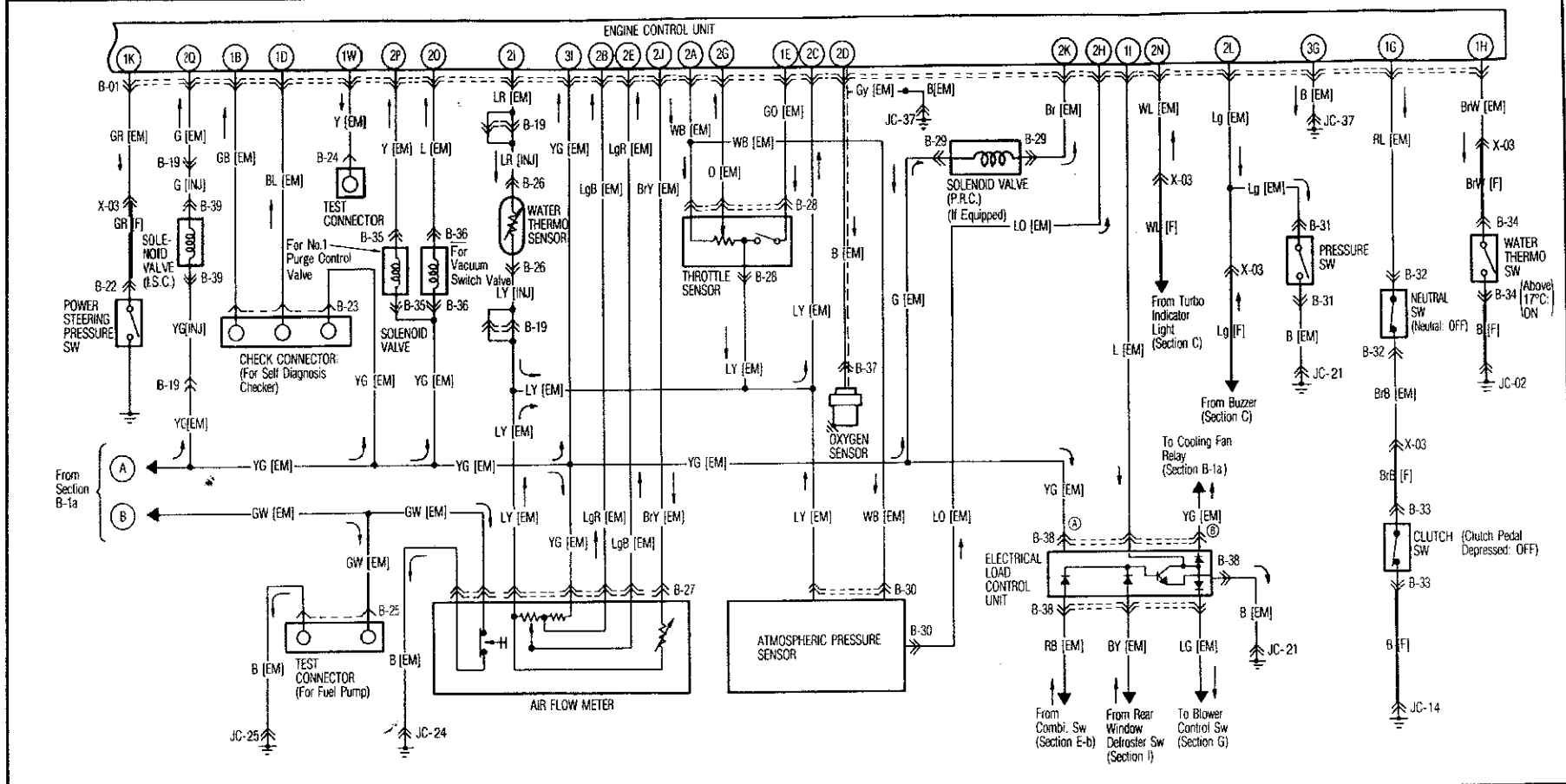

<p><b>B-01 Engine Control Unit [EM]</b></p>	<p><b>B-19 Connector Between Emission [EM] And Injector [INU] Harness</b></p>	<p><b>B-22 Power Steering Pressure Sw [F]</b></p> <p><b>B-26 Water Thermo Sensor [INU]</b></p> <p><b>B-30 Atmospheric Pressure Sensor [EM]</b></p>	<p><b>B-23 Check Connector [EM]</b></p> <p><b>B-27 Air Flow Meter [EM]</b></p> <p><b>B-31 Pressure Sw [EM]</b></p> <p><b>B-38 Electrical Load Control Unit [EM]</b></p>	<p><b>B-24 Test Connector [EM]</b></p> <p><b>B-28 Throttle Sensor [EM]</b></p> <p><b>B-32 Neutral Sw [EM]</b></p>	<p><b>B-25 Test Connector [EM]</b></p> <p><b>B-29 Solenoid Valve (P.R.C.) [EM]</b></p> <p><b>B-33 Clutch Sw [F]</b></p>
<p><b>B-34 Water Thermo Sw [F]</b></p>	<p><b>B-35 Solenoid Valve [EM] (For No.1 Purge Control Valve)</b></p>	<p><b>B-36 Solenoid Valve [EM] (For Vacuum Switch Valve)</b></p>	<p><b>B-37 Oxygen Sensor [EM]</b></p>	<p><b>B-39 Solenoid Valve (I.S.C.) [INU]</b></p>	

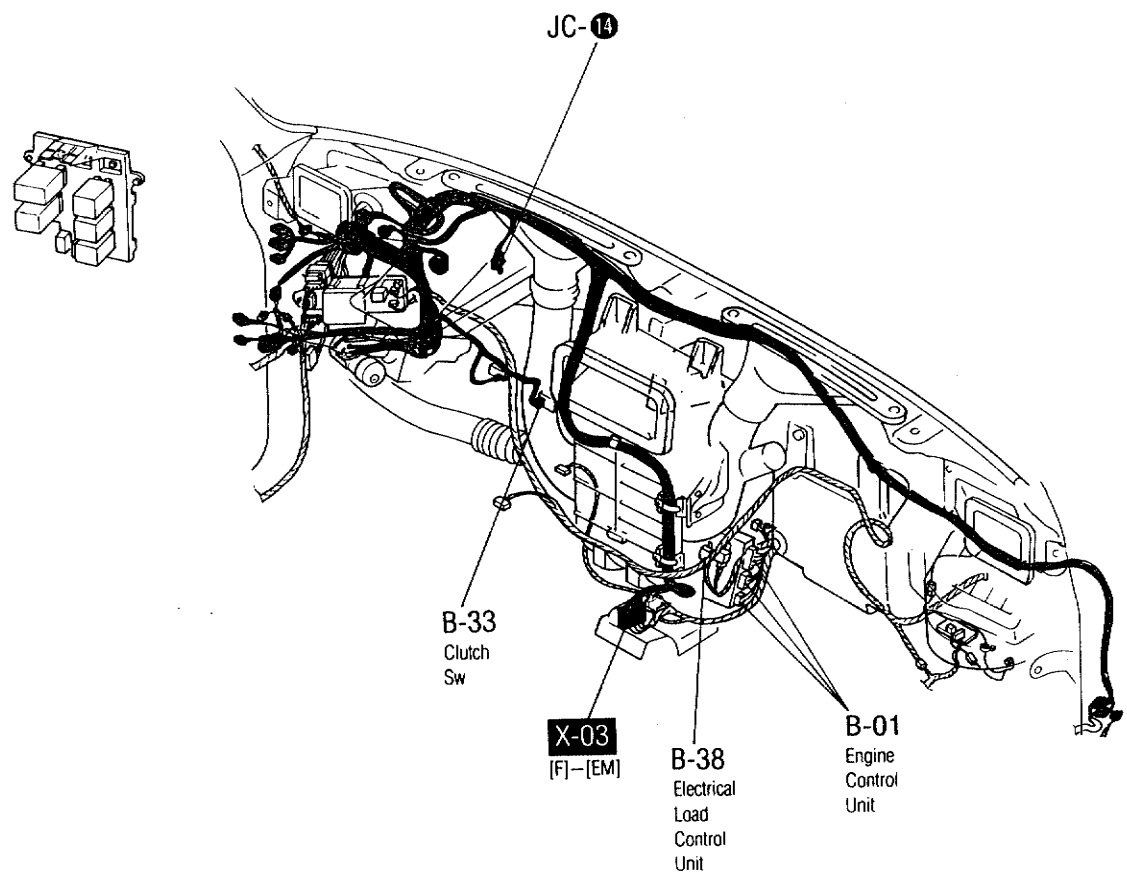
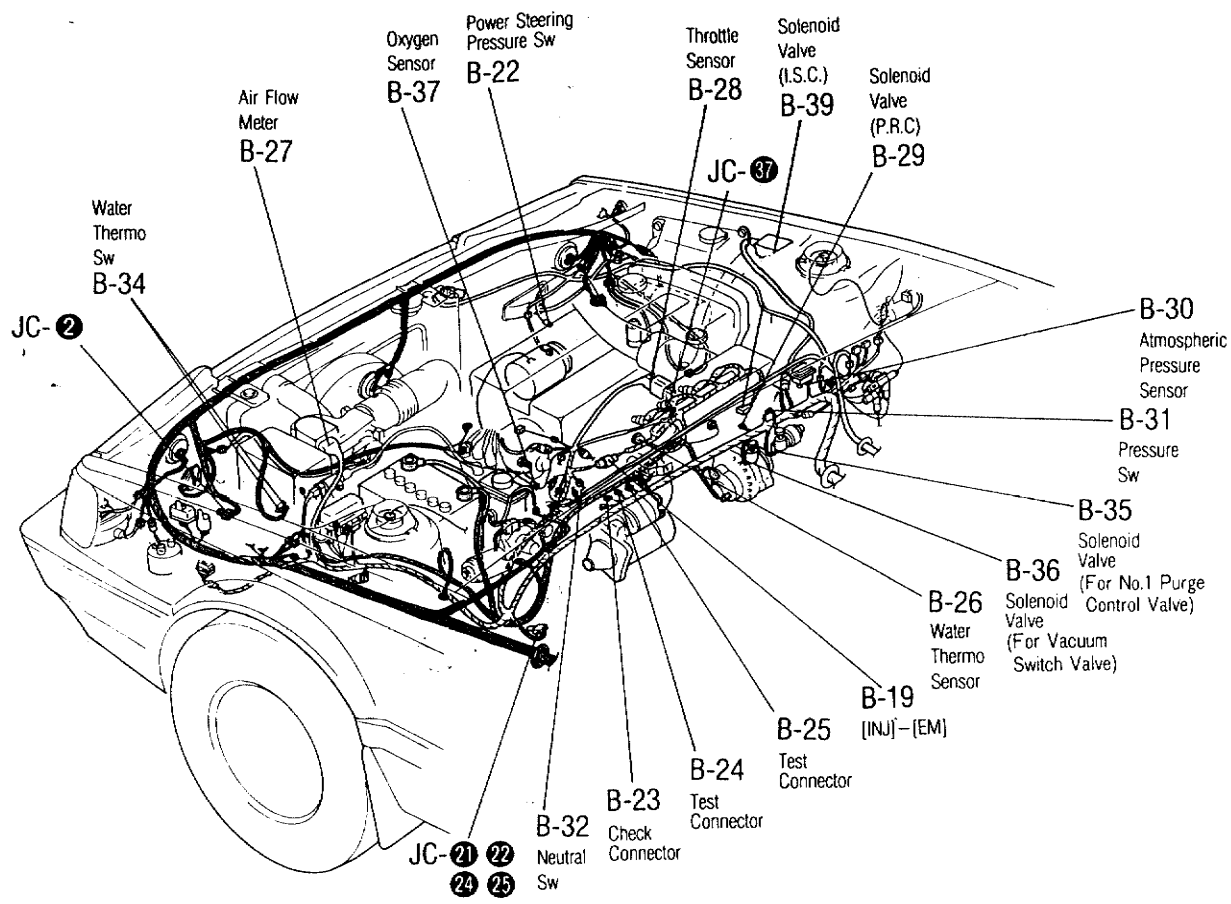

B-2a

■ IGNITION SYSTEM ■ ENGINE & FUEL CONTROL SYSTEM  
 ■ COOLING FAN SYSTEM

Note: \* Not Used

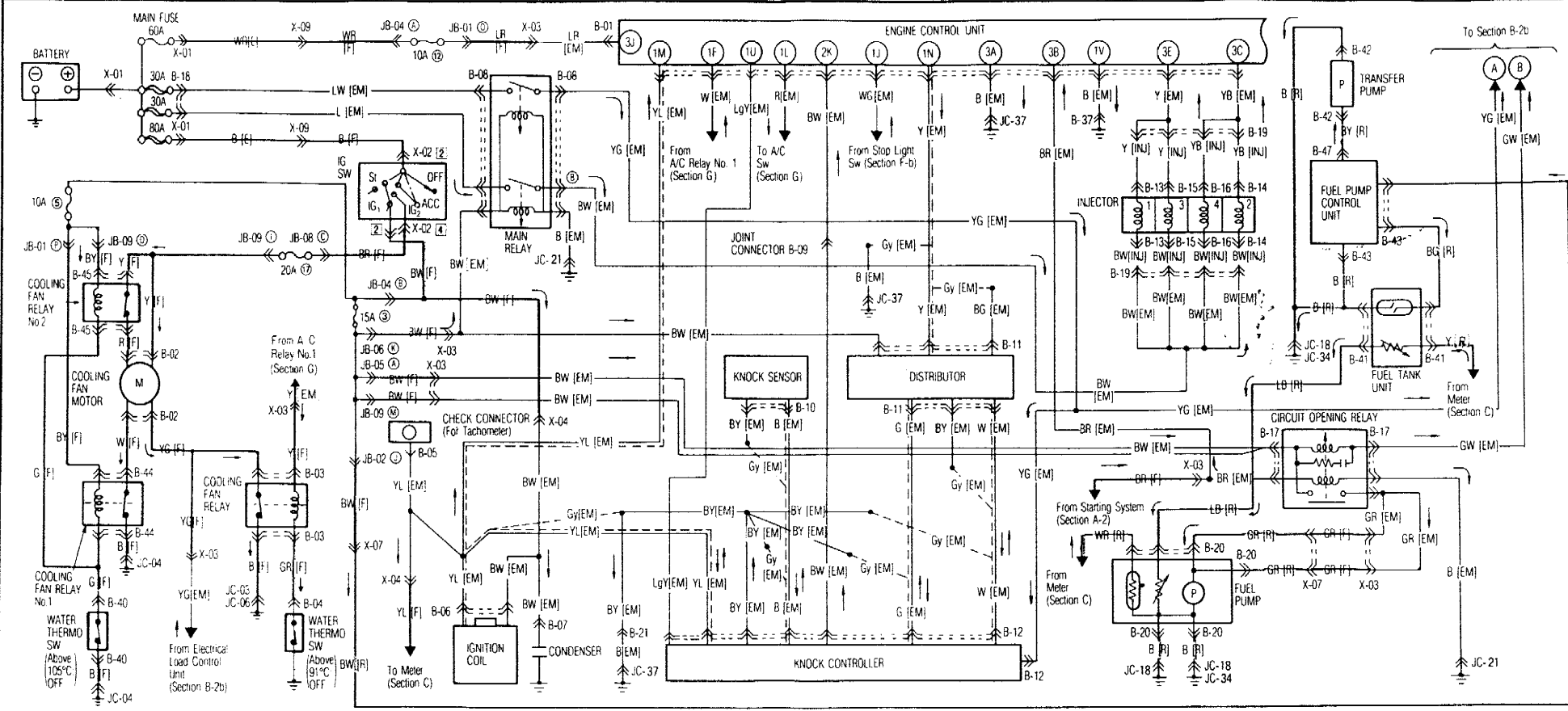

<b>B-01 Engine Control Unit [EM]</b> 		<b>B-02 Cooling Fan Motor [F]</b> 		<b>B-03 Cooling Fan Relay [F]</b> 		<b>B-04 Water Thermo Sw [F]</b> 		<b>B-05 Check Connector [EM]</b> 									
<b>B-06 IG Coil [EM]</b> 		<b>B-07 Condenser [EM]</b> 		<b>B-08 Main Relay [EM]</b> 		<b>B-09 Joint Connector [EM]</b> 		<b>B-10 Knock Sensor [EM]</b> 		<b>B-11 Distributor [EM]</b> 		<b>B-12 Knock Controller [EM]</b> 		<b>B-13 Injector No.1 [INJ]</b> 		<b>B-14 Injector No.2 [INJ]</b> 	
<b>B-15 Injector No.3 [INJ]</b> 		<b>B-16 Injector No.4 [INJ]</b> 		<b>B-17 Circuit Opening Relay [EM]</b> 		<b>B-18 Main Fuse [EM]</b> 		<b>B-20 Fuel Pump [R]</b> 		<b>B-21 Joint Connector [EM]</b> 		<b>B-40 Water Thermo Sw [F]</b> 		<b>B-19 Connector Between Emission [EM] And Injector Harness [INJ]</b> 			
<b>B-41 Fuel Tank Unit [R]</b> 		<b>B-42 Transfer Pump [R]</b> 		<b>B-43 Fuel Pump Control Unit [R]</b> 		<b>B-44 Cooling Fan Relay No. 1 [F]</b> 		<b>B-45 Cooling Fan Relay No. 2 [F]</b> 									

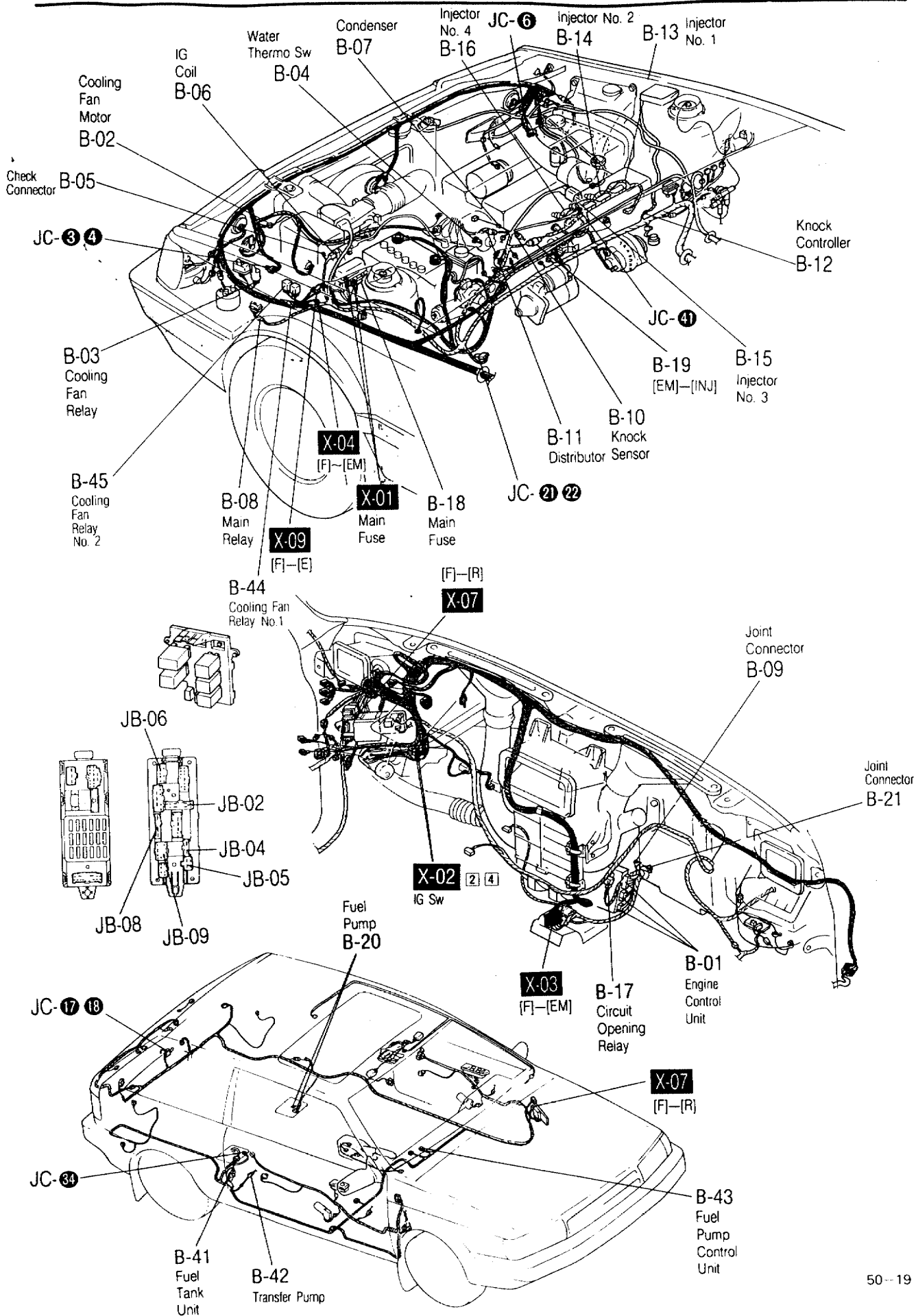

B-2b

For Turbo With 4WD

ENGINE & FUEL CONTROL SYSTEM

Note: \* Not Used

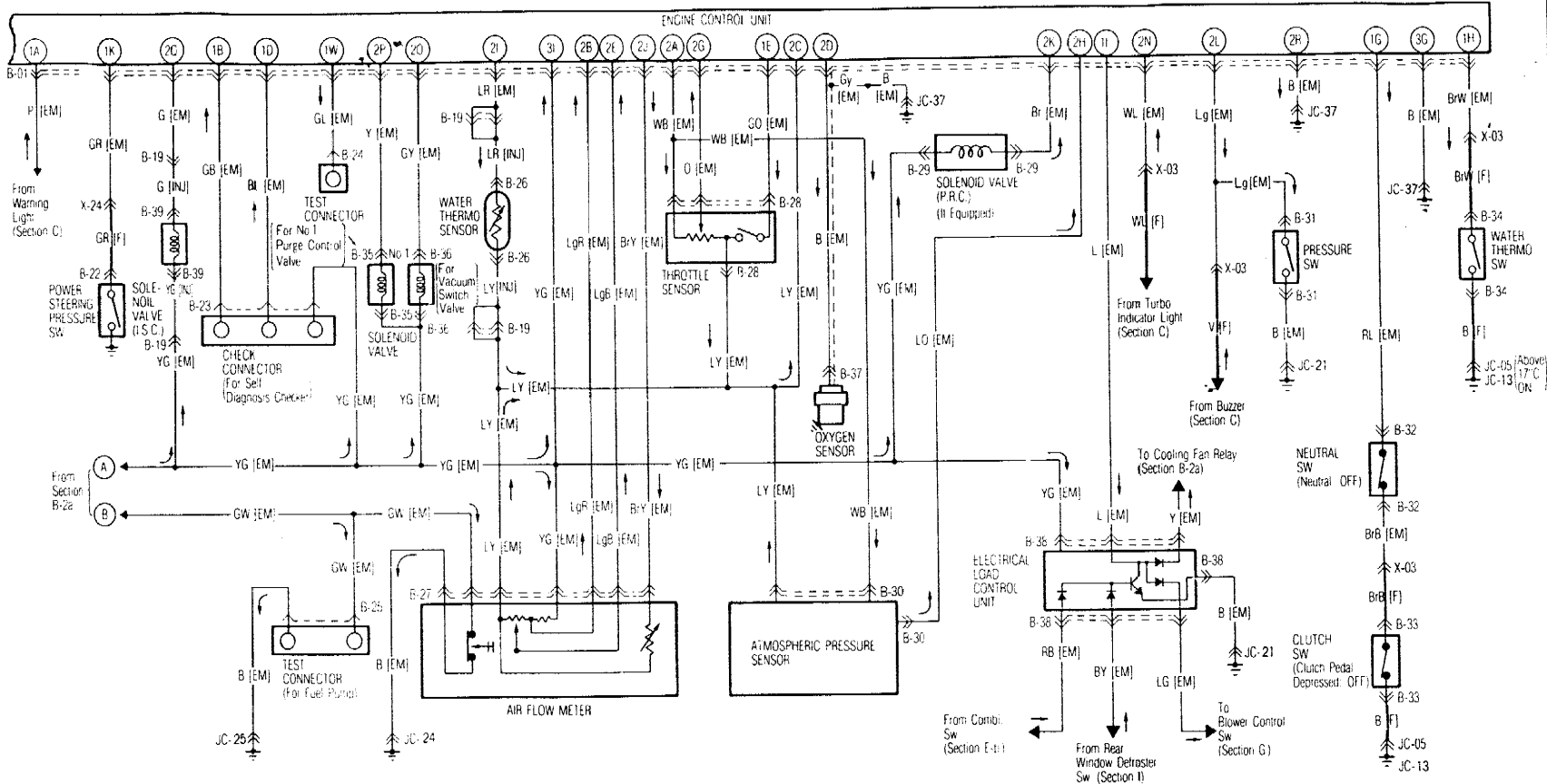

<p><b>B-01 Engine Control Unit [EM]</b></p>	<p><b>B-19 Connector Between Emission [EM] And Injector [INJ] Harness</b></p>	<p><b>B-22 Power Steering Pressure Sw [F]</b></p>	<p><b>B-23 Check Connector [EM]</b></p>	<p><b>B-24 Test Connector [EM]</b></p>	<p><b>B-25 Test Connector [EM]</b></p>
<p><b>B-34 Water Thermo Sw [F]</b></p>	<p><b>B-35 Solenoid Valve [EM] (For No 1 Purge Control Valve)</b></p>	<p><b>B-26 Water Thermo Sensor [INJ]</b></p>	<p><b>B-27 Air Flow Meter [EM]</b></p>	<p><b>B-28 Throttle Sensor [EM]</b></p>	<p><b>B-29 Solenoid Valve (P.R.C.) [EM]</b></p>
<p><b>B-36 Solenoid Valve [EM] (For Vacuum Switch Valve)</b></p>	<p><b>B-37 Oxygen Sensor [EM]</b></p>	<p><b>B-30 Atmospheric Pressure Sensor [EM]</b></p>	<p><b>B-31 Pressure Sw [EM]</b></p>	<p><b>B-32 Neutral Sw [EM]</b></p>	<p><b>B-33 Clutch Sw [F]</b></p>
<p><b>B-34 Water Thermo Sw [F]</b></p>	<p><b>B-35 Solenoid Valve [EM] (For No 1 Purge Control Valve)</b></p>	<p><b>B-36 Solenoid Valve [EM] (For Vacuum Switch Valve)</b></p>	<p><b>B-37 Oxygen Sensor [EM]</b></p>	<p><b>B-38 Electrical Load Control Unit [EM]</b></p>	<p><b>B-39 Solenoid Valve (S.C.) [INJ]</b></p>



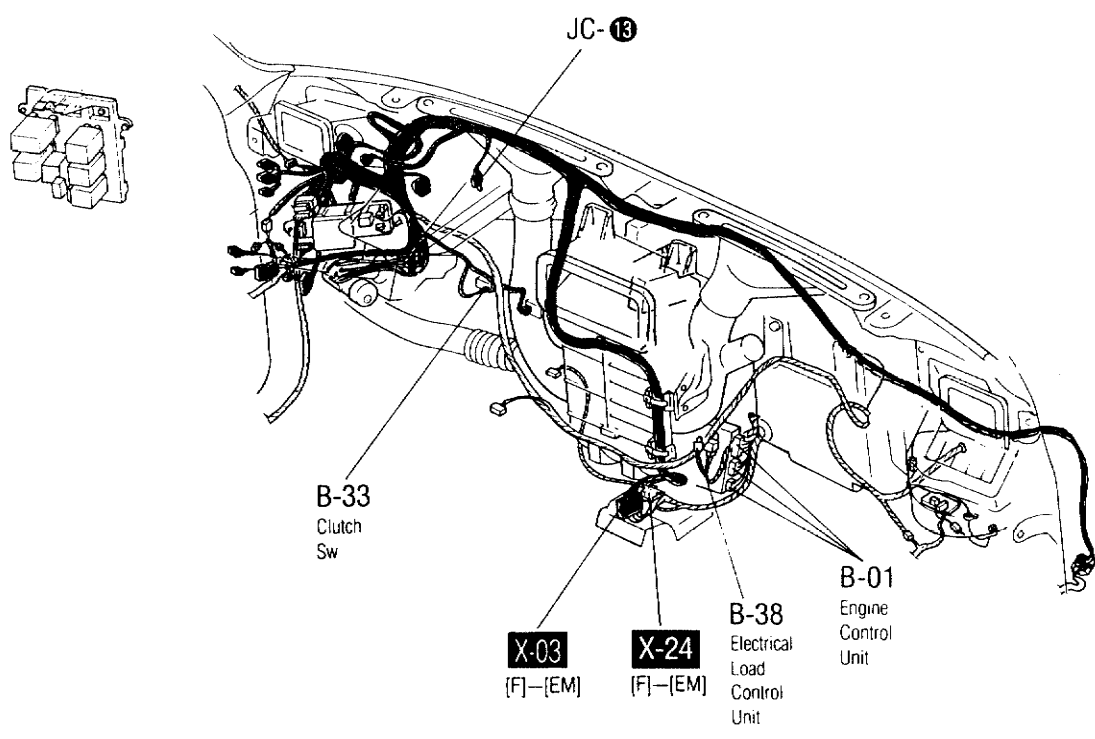
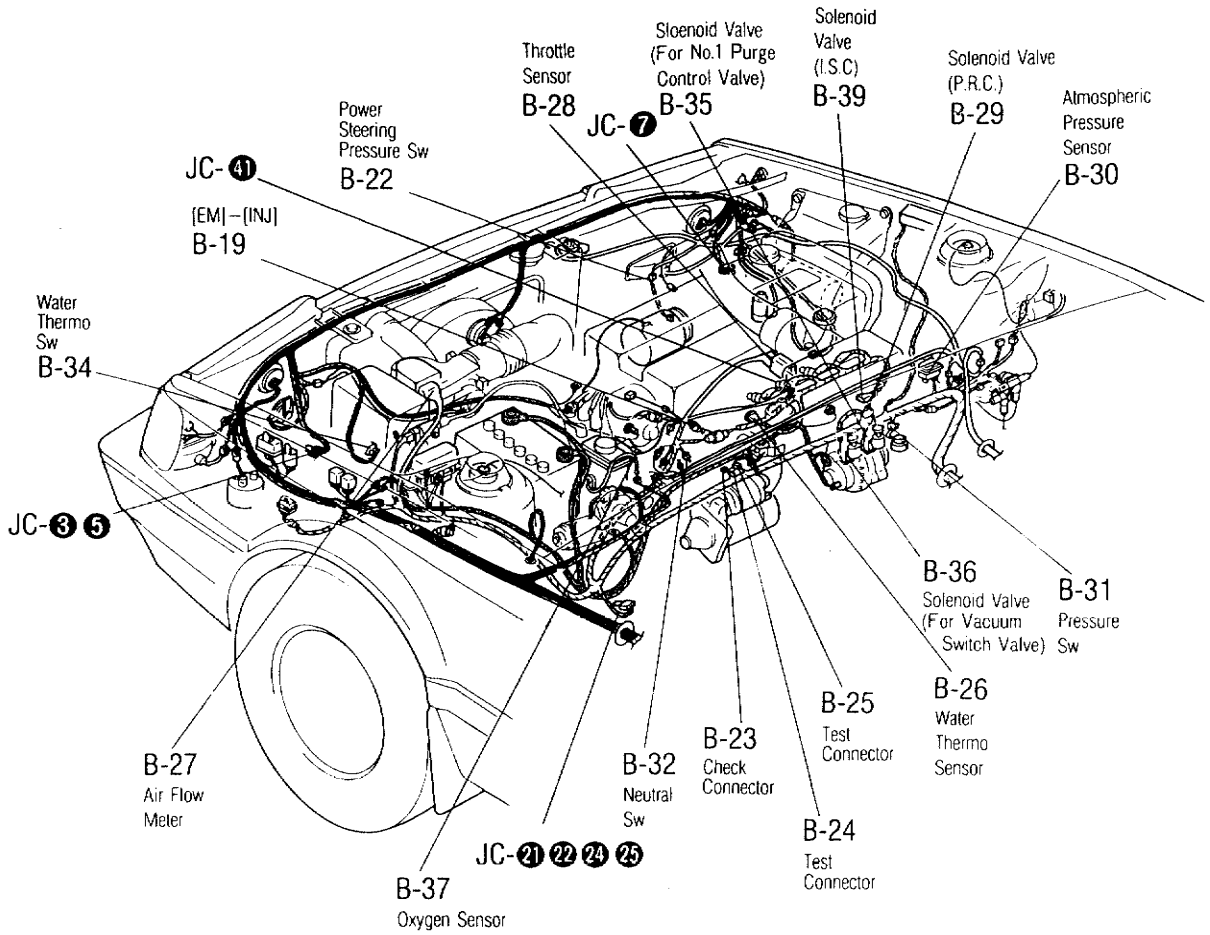

**B3a For Non Turbo**

- IGNITION SYSTEM
- COOLING FAN SYSTEM

- ENGINE & FUEL CONTROL SYSTEM
- 4AT CONTROL SYSTEM

Note \* Not Used

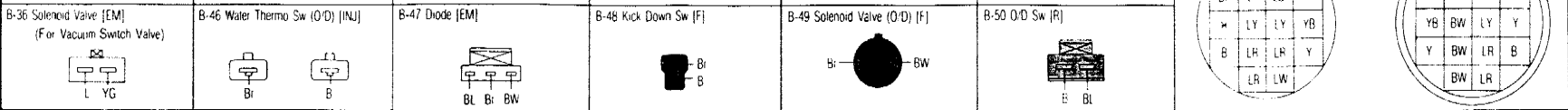
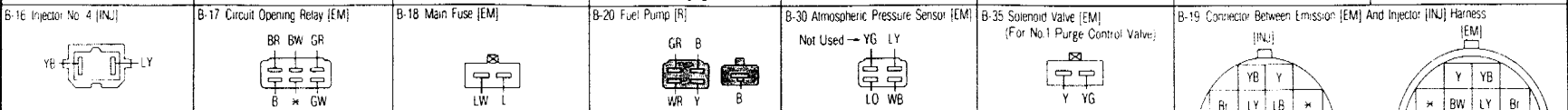
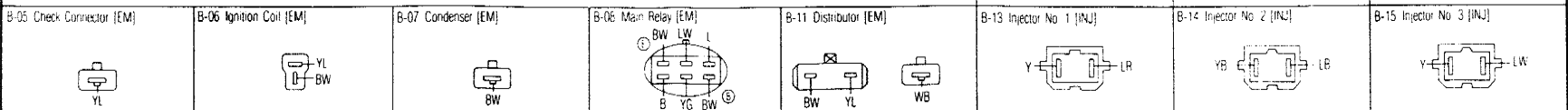
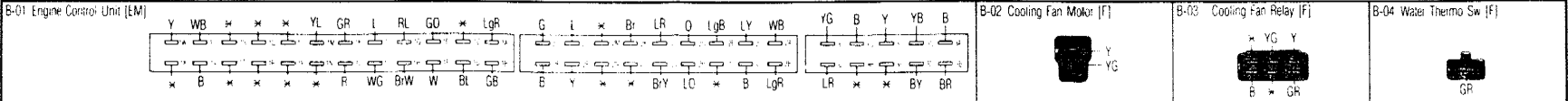
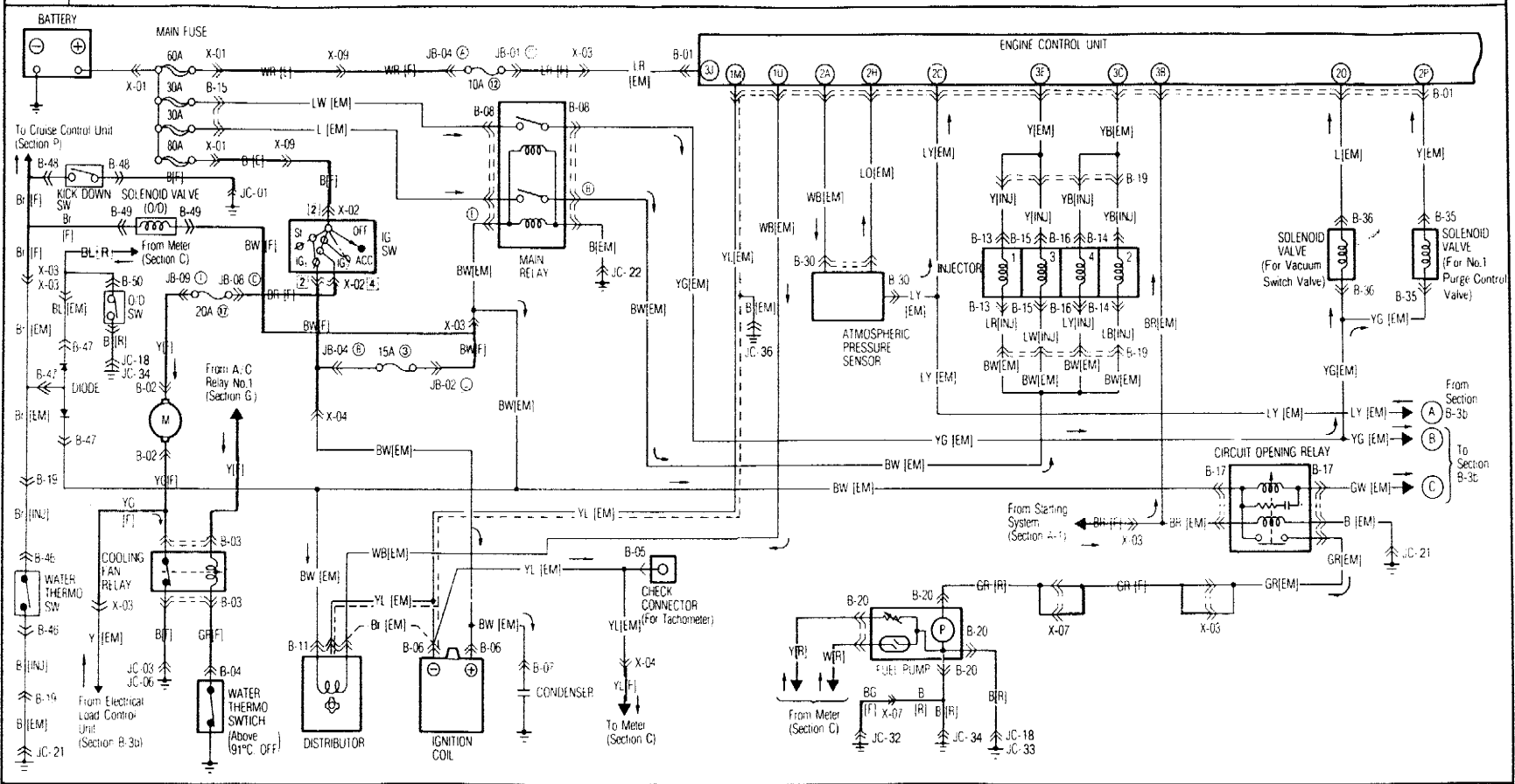

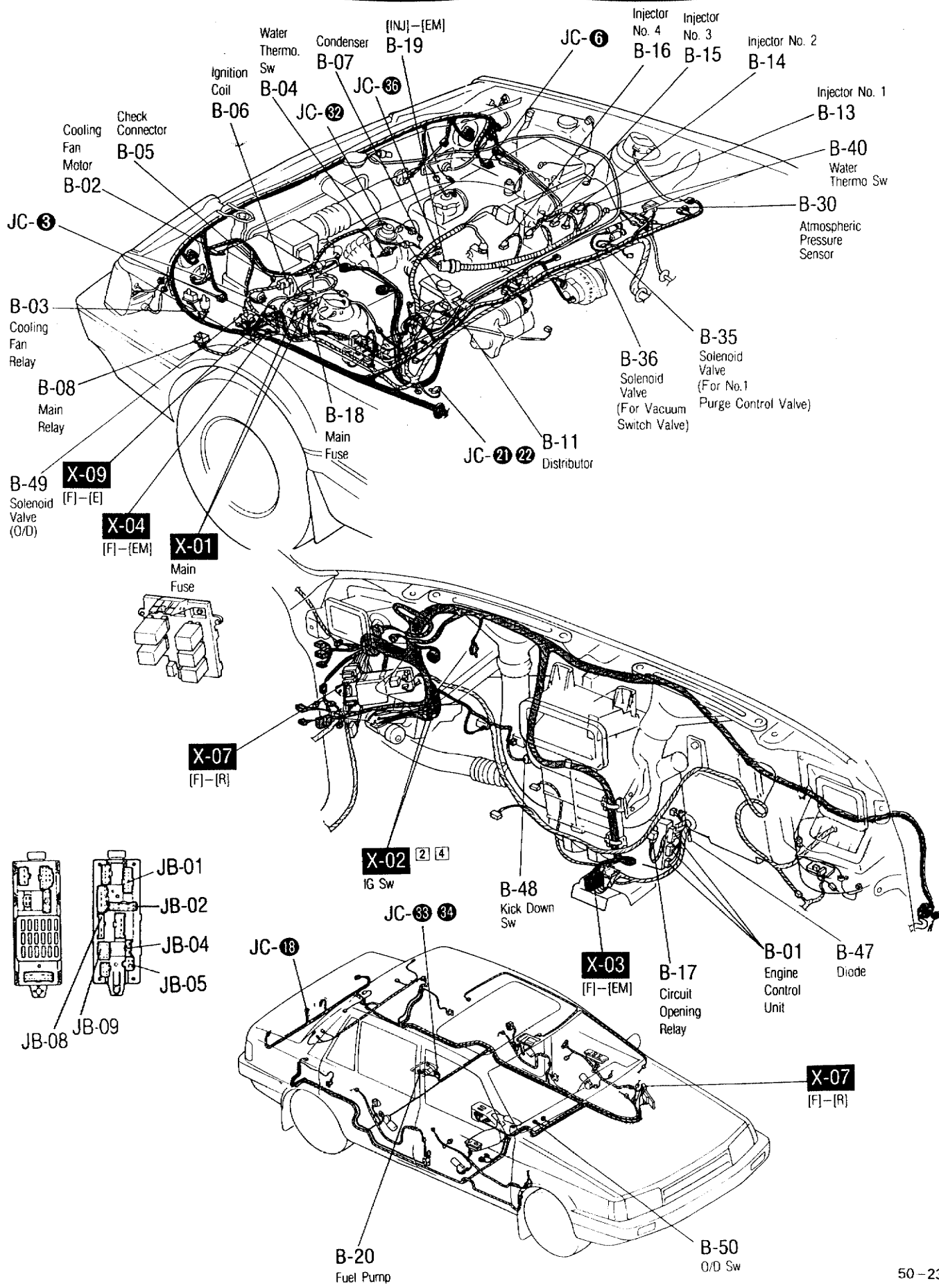

B-3b

For Non Turbo ■ ENGINE & FUEL CONTROL SYSTEM

Note \* Not Used

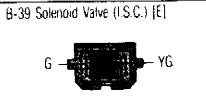
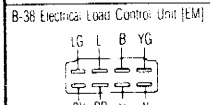
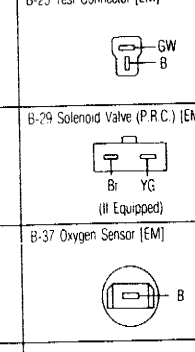
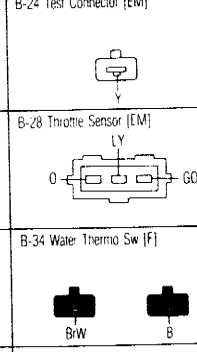
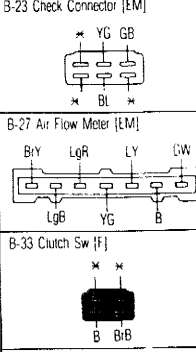
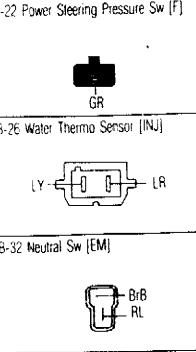
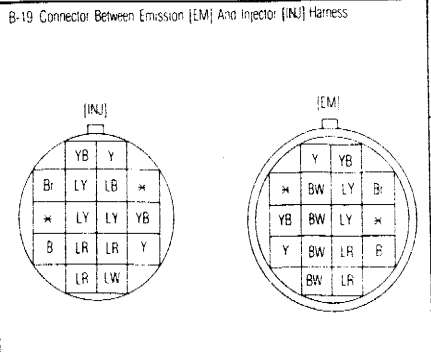
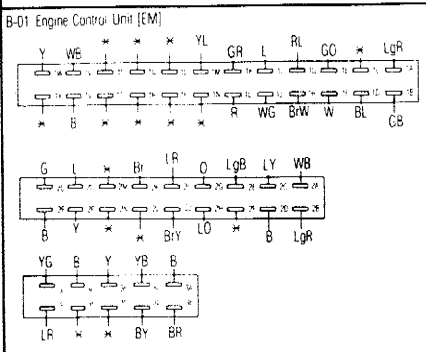
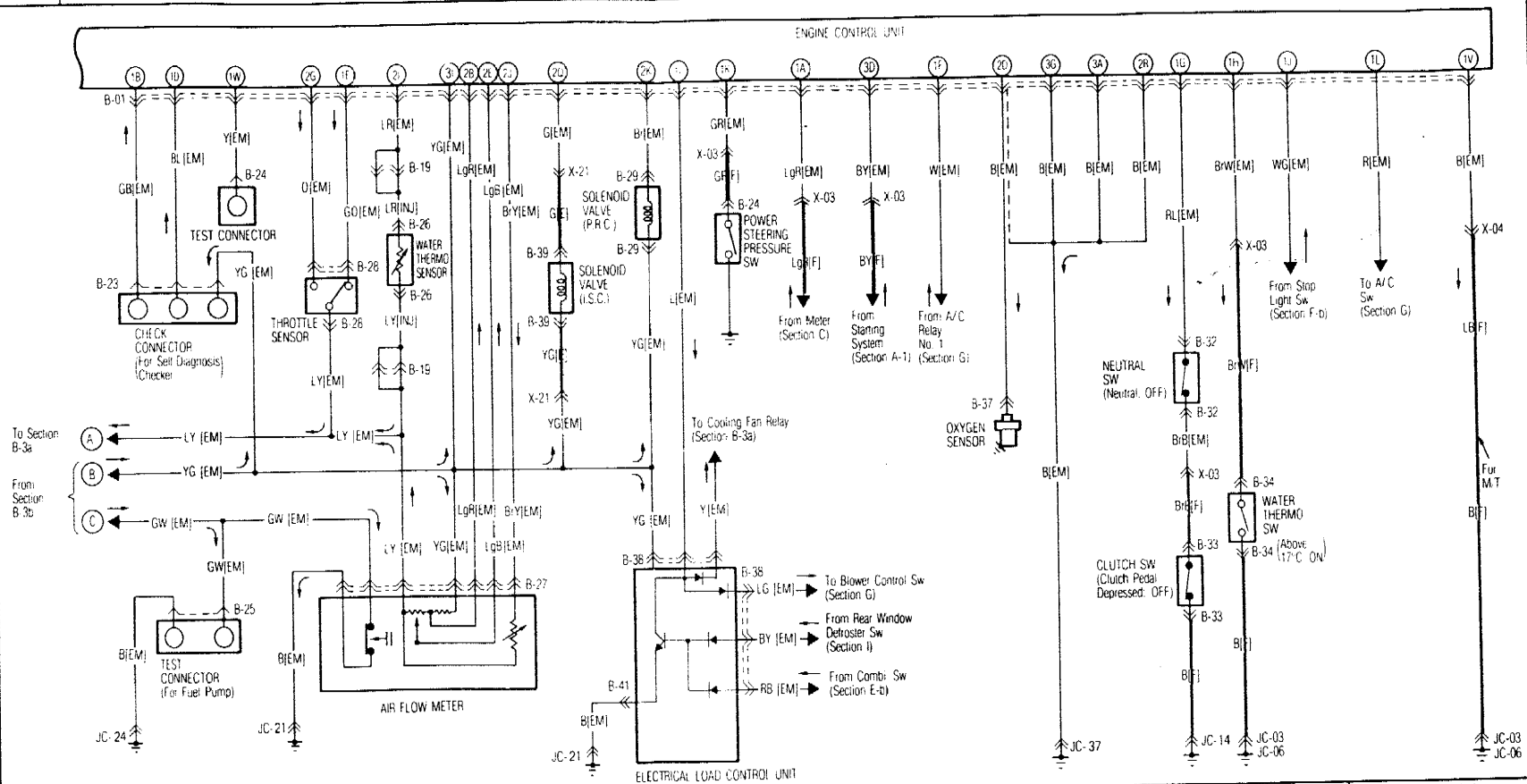

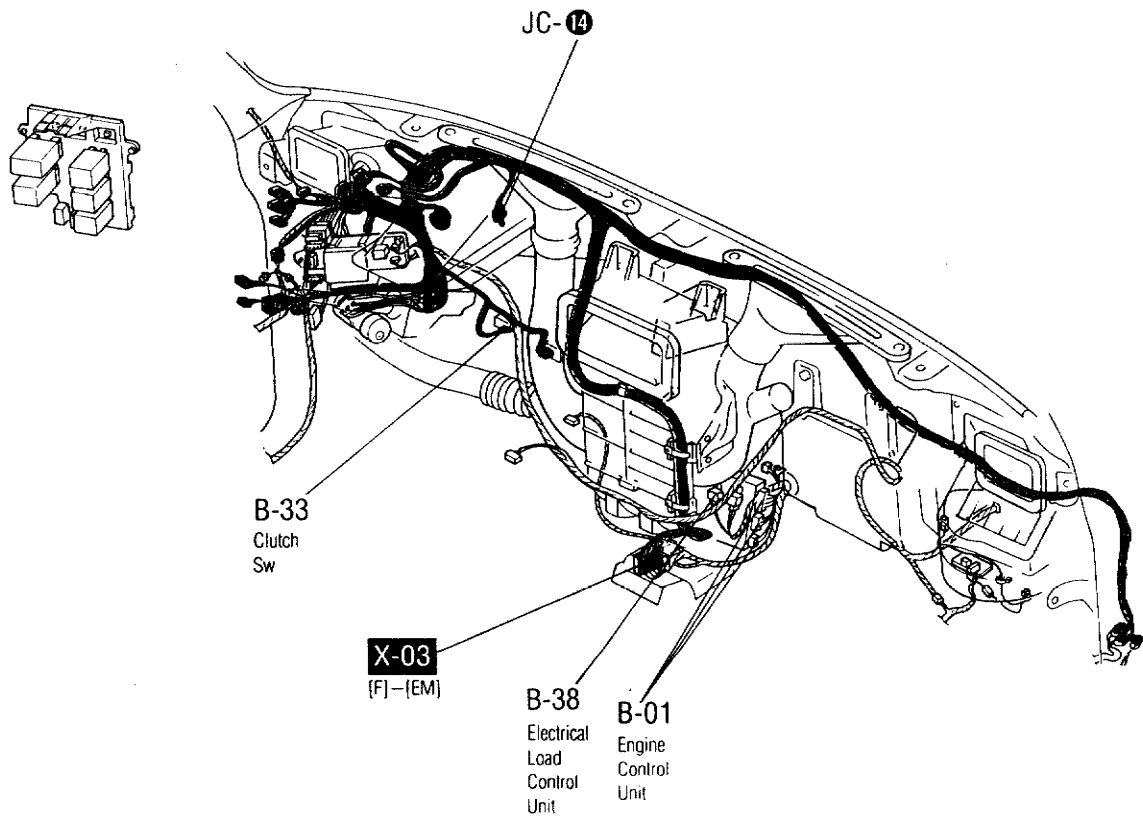
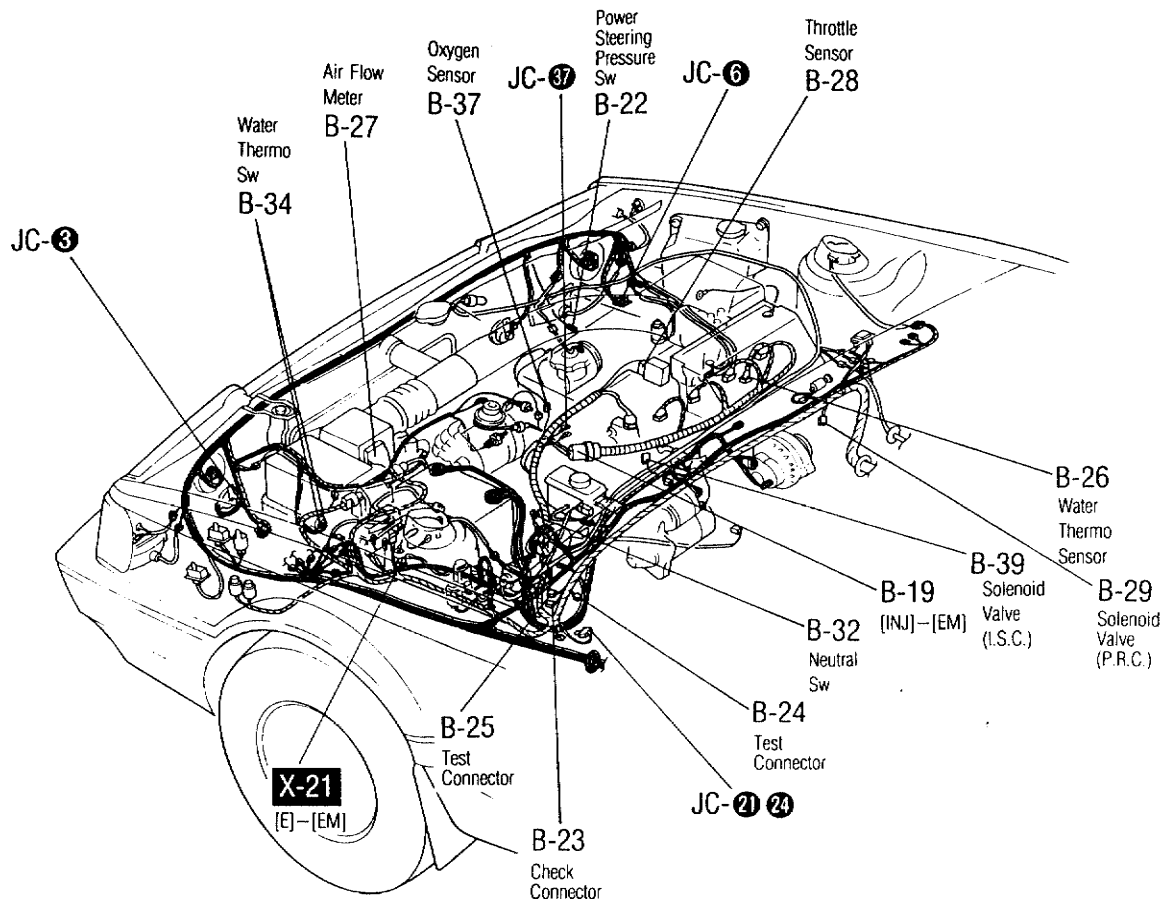

METERS & WARNING LIGHTS

Note: ( ) Without Tachometer  
 < > For 4WD  
 \* For Turbo Without 4WD  
 x Not Used

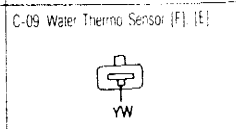
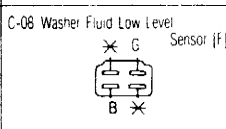
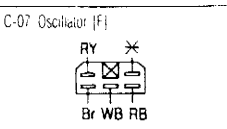
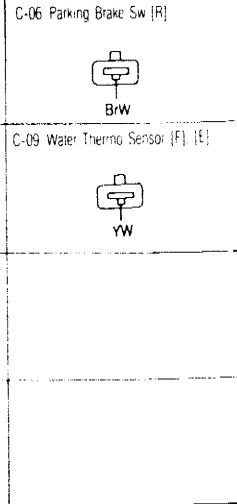
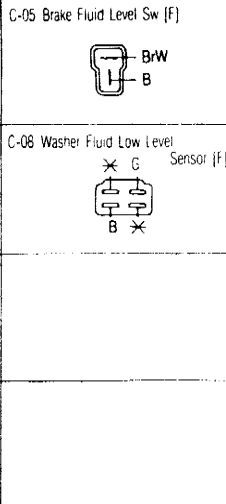
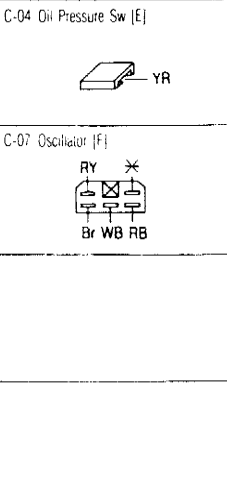
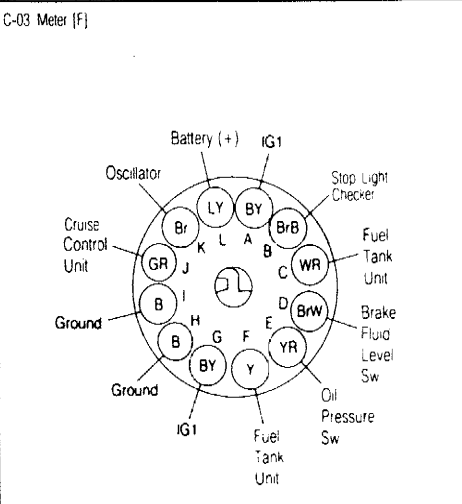
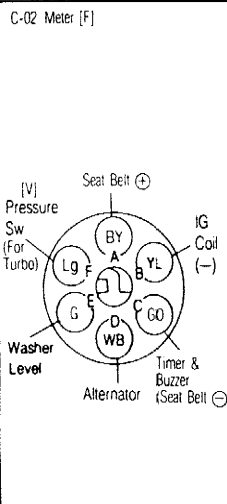
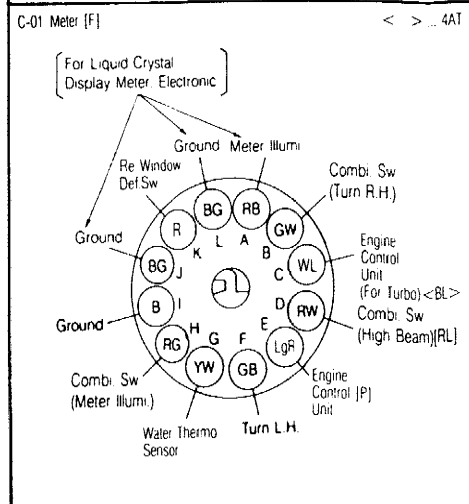
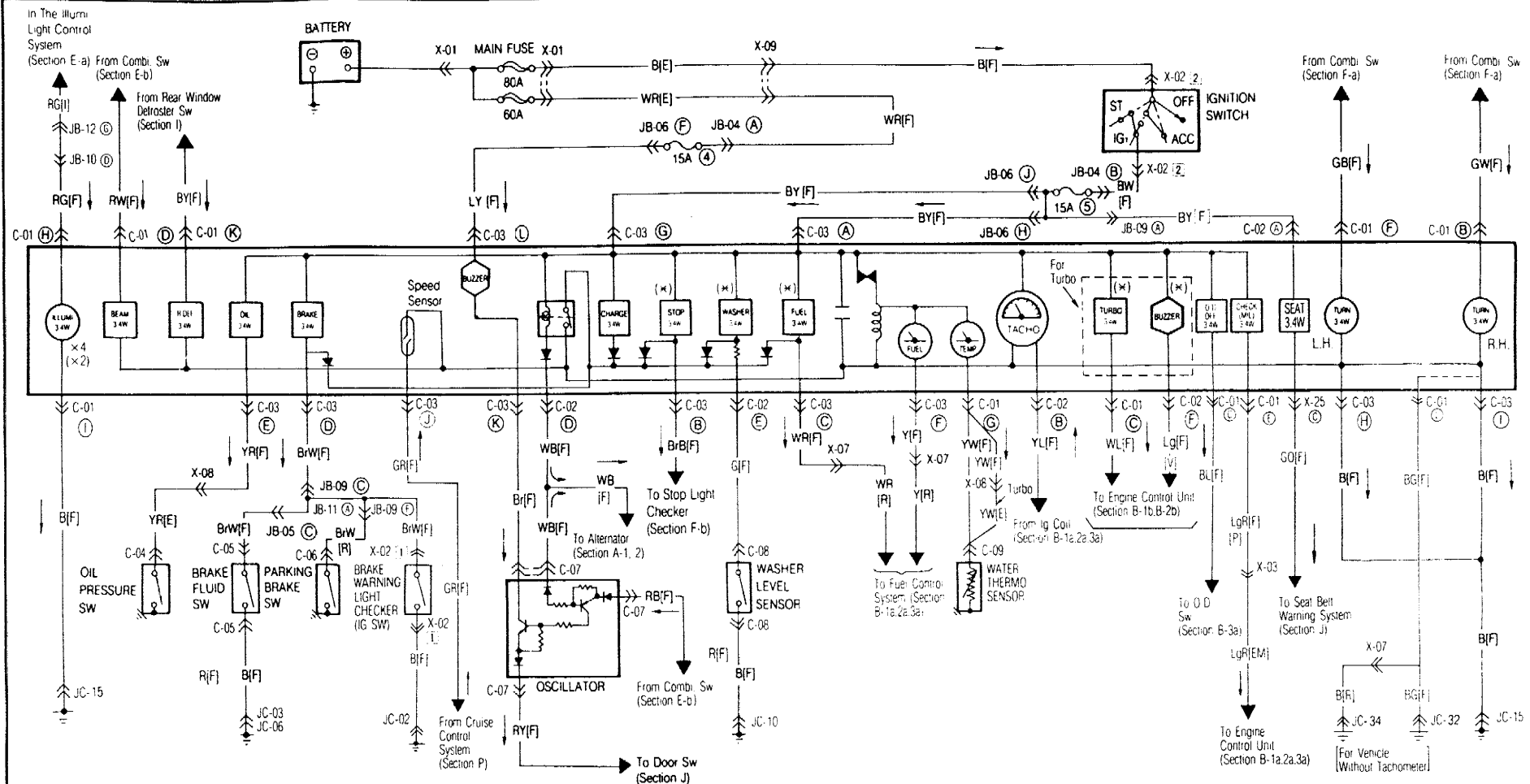

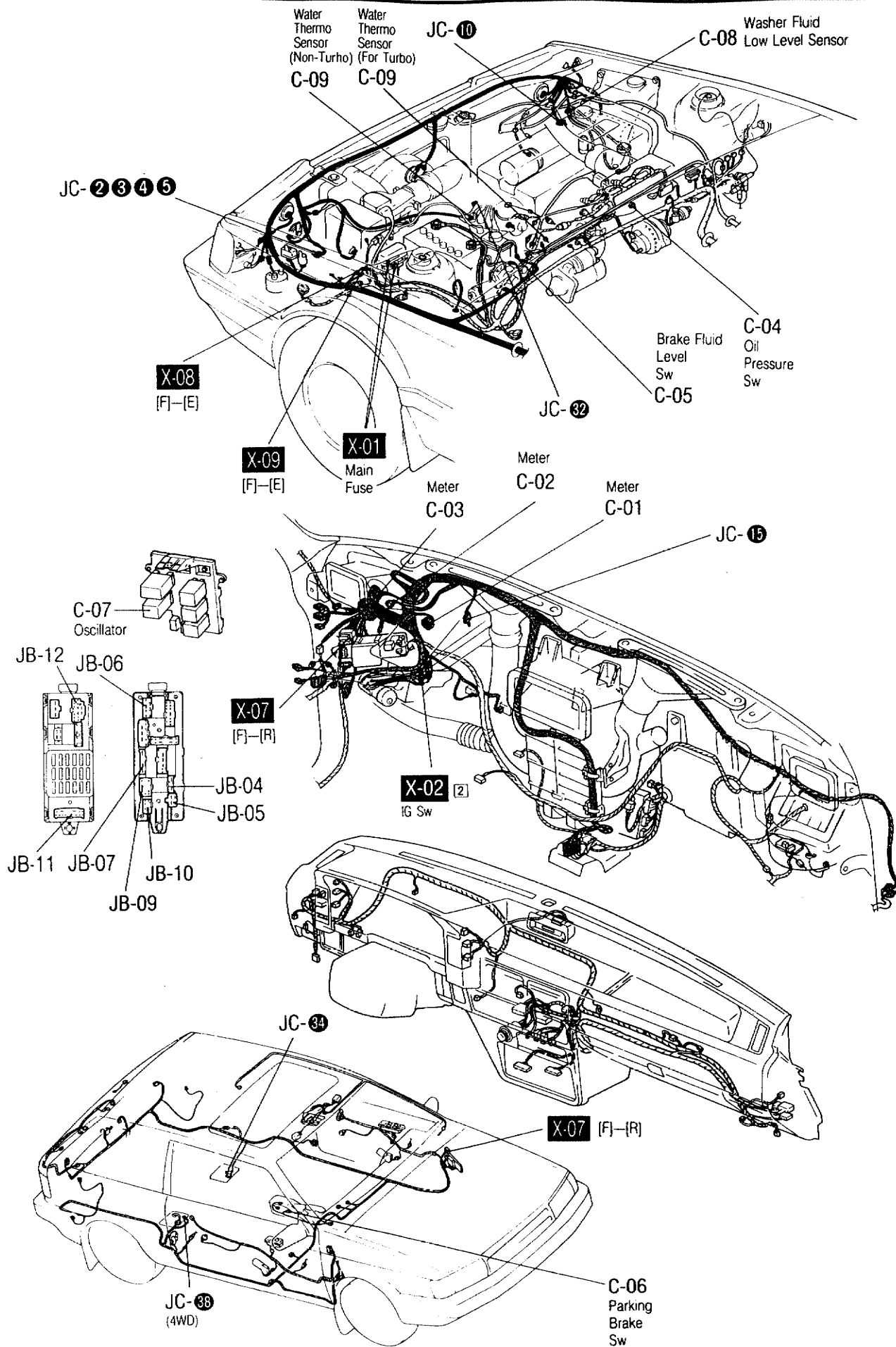

# D

## FRONT WIPER & WASHER REAR WIPER & WASHER (3 & 5 Door)

Note: \* ... Not Used

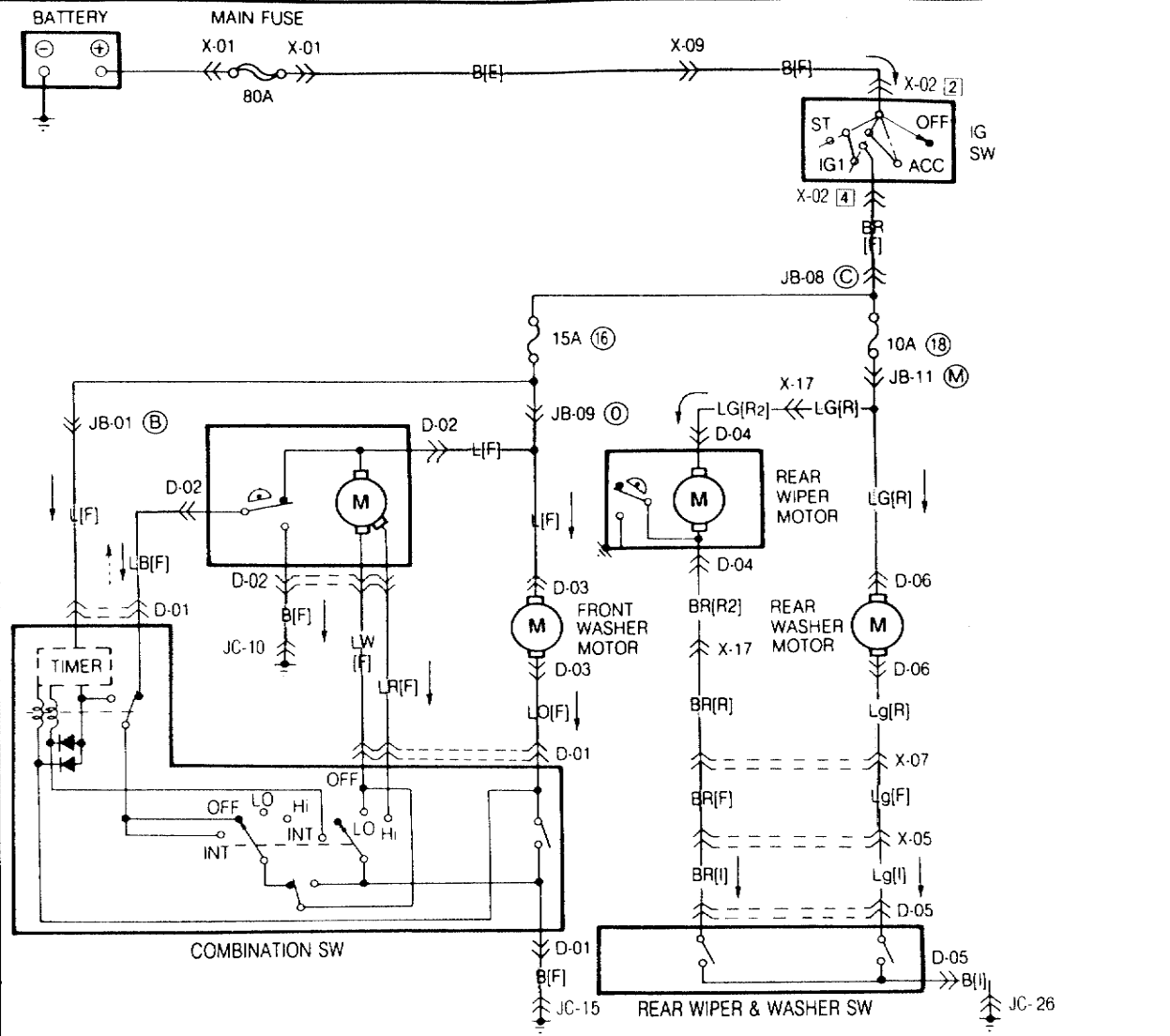

<p>D-01 Combination Sw [F]</p>	<p>D-02 Front Wiper Motor [F]</p>	<p>D-03 Front Washer Motor [F]</p>	<p>D-04 Rear Wiper Motor [R2]</p> <p>(3 &amp; 5 Door)</p>
<p>D-05 Rear Wiper &amp; Washer Sw [I]</p> <p>(3 &amp; 5 Door)</p>	<p>D-06 Rear Washer Motor [R]</p> <p>(3 &amp; 5 Door)</p>		



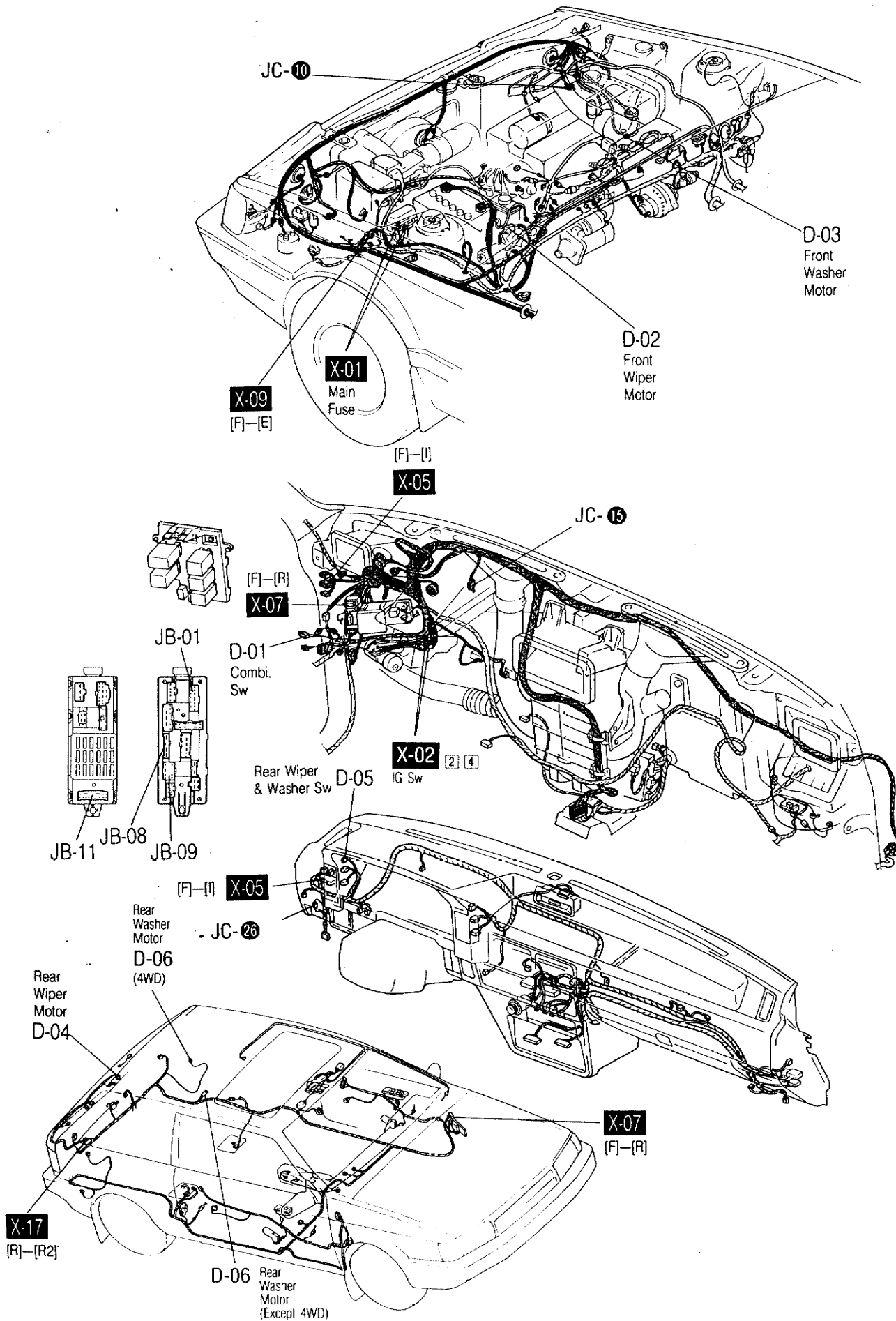

# E-a ILLUMINATION LIGHT CONTROL SYSTEM

Note: Components are also illustrated in each system that is used.

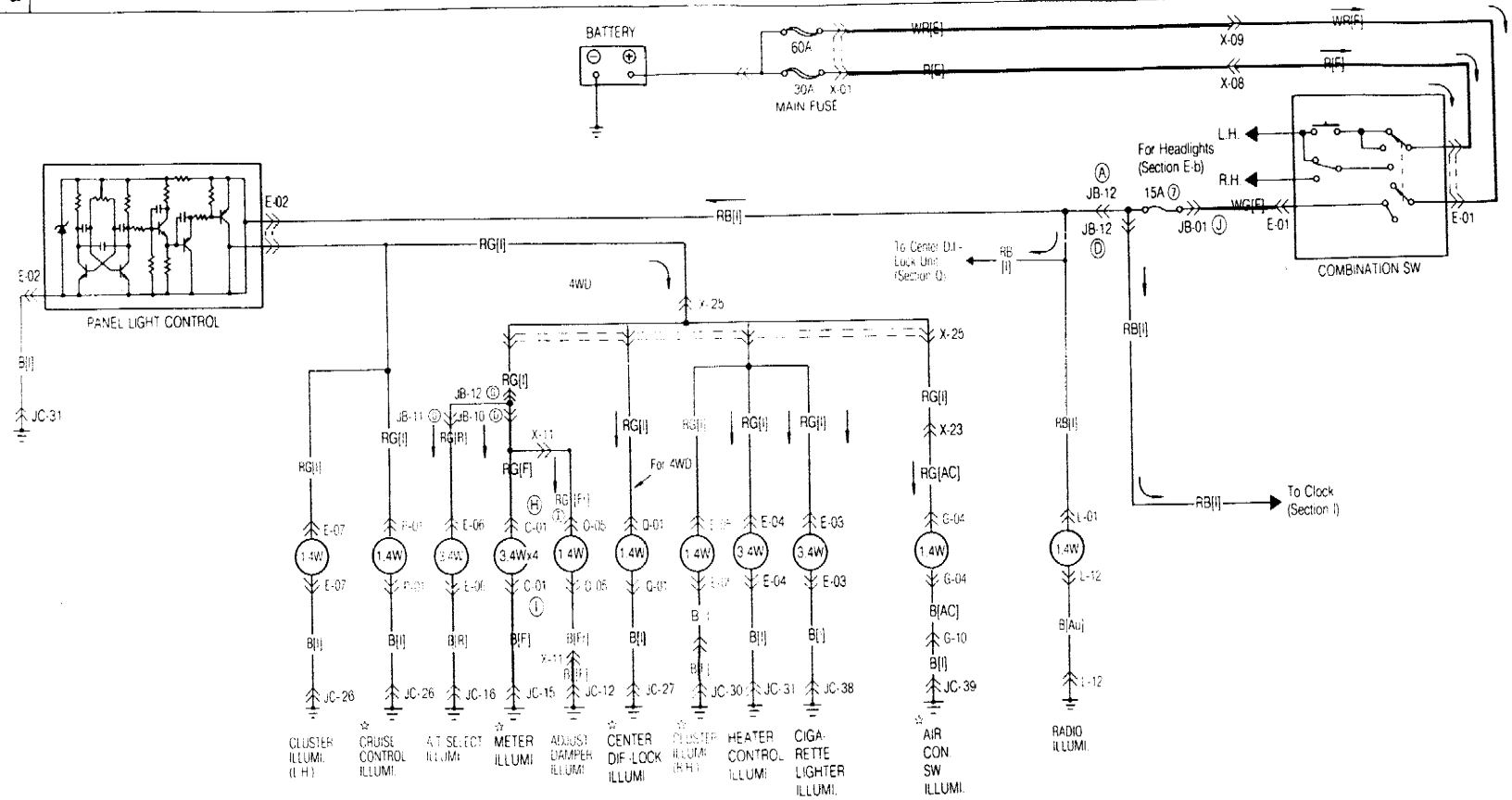

<p>E-01 Combination Sw [F]</p>	<p>E-02 Panel Light Control [I]</p>	<p>E-03 Cigarette Lighter Illum. [I]</p>	<p>E-04 Heater Control Illum. [I]</p>	<p>E-05 Cluster Illum. R.H. [I]</p>	<p>E-06 A/T Select Illum. [R]</p>	<p>E-07 Cluster Illum. L.H. [I]</p>
<p>G-04 Air Con Sw [AC]</p>	<p>G-10 Connector Between Air Con. [AC] &amp; Air Con. [AC] Harness</p>	<p>L-01 Radio [I]</p>	<p>L-12 Ground [Au]</p>	<p>Q-05 Adjust. Damper Sw [F]</p>	<p>P-01 Cruise Control Main Sw [I]</p>	
<p>Q-01 Center Dif-Lock Unit [I]</p>						

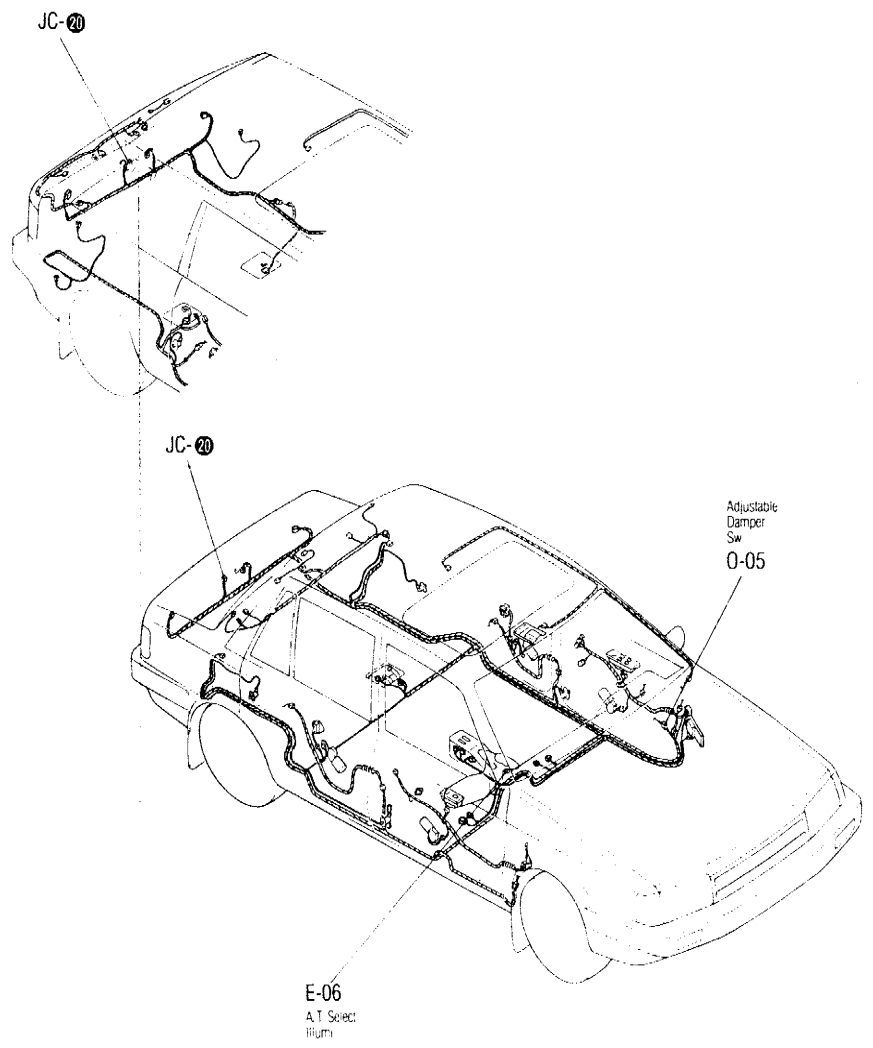
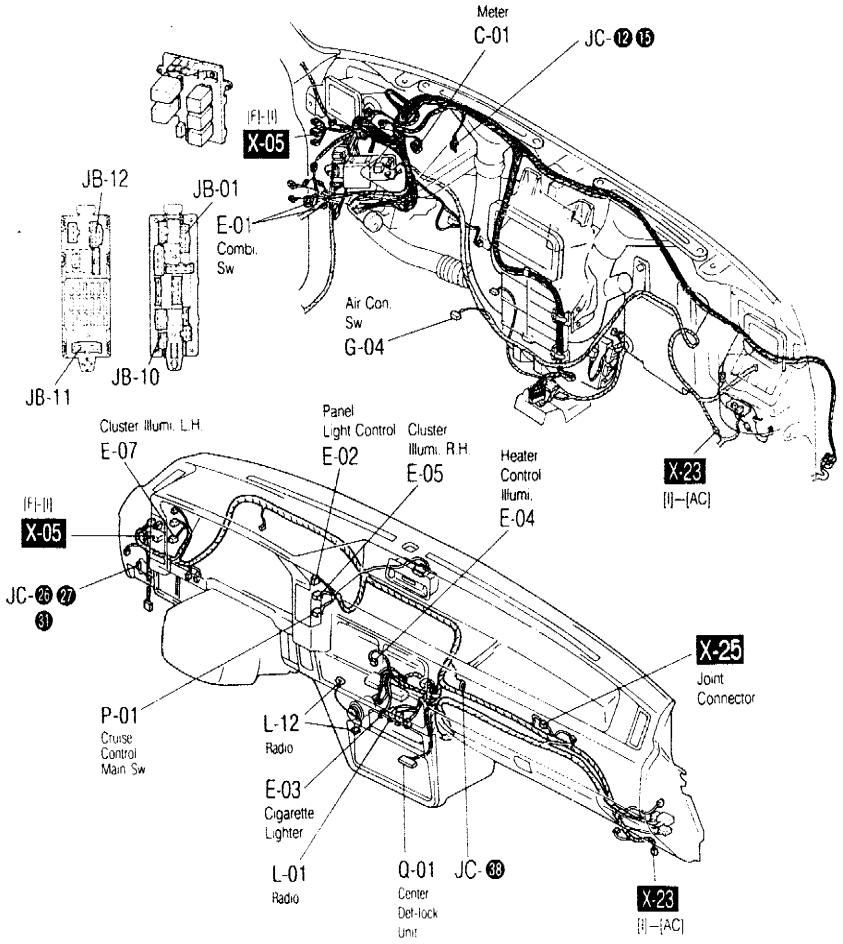
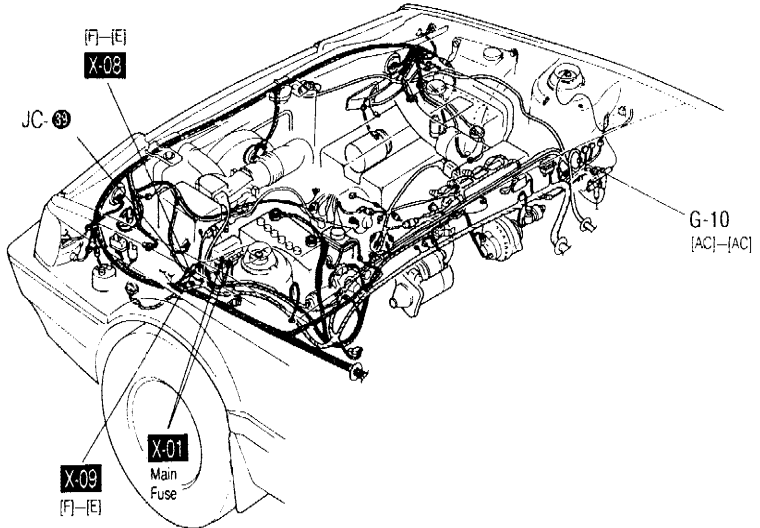

**E-b**

- FRONT MARKER LIGHTS
- PARKING LIGHTS
- TAIL LIGHTS

- LICENSE LIGHTS
- HEADLIGHTS
- REAR MARKER LIGHTS

Note:  
× ... Not Used

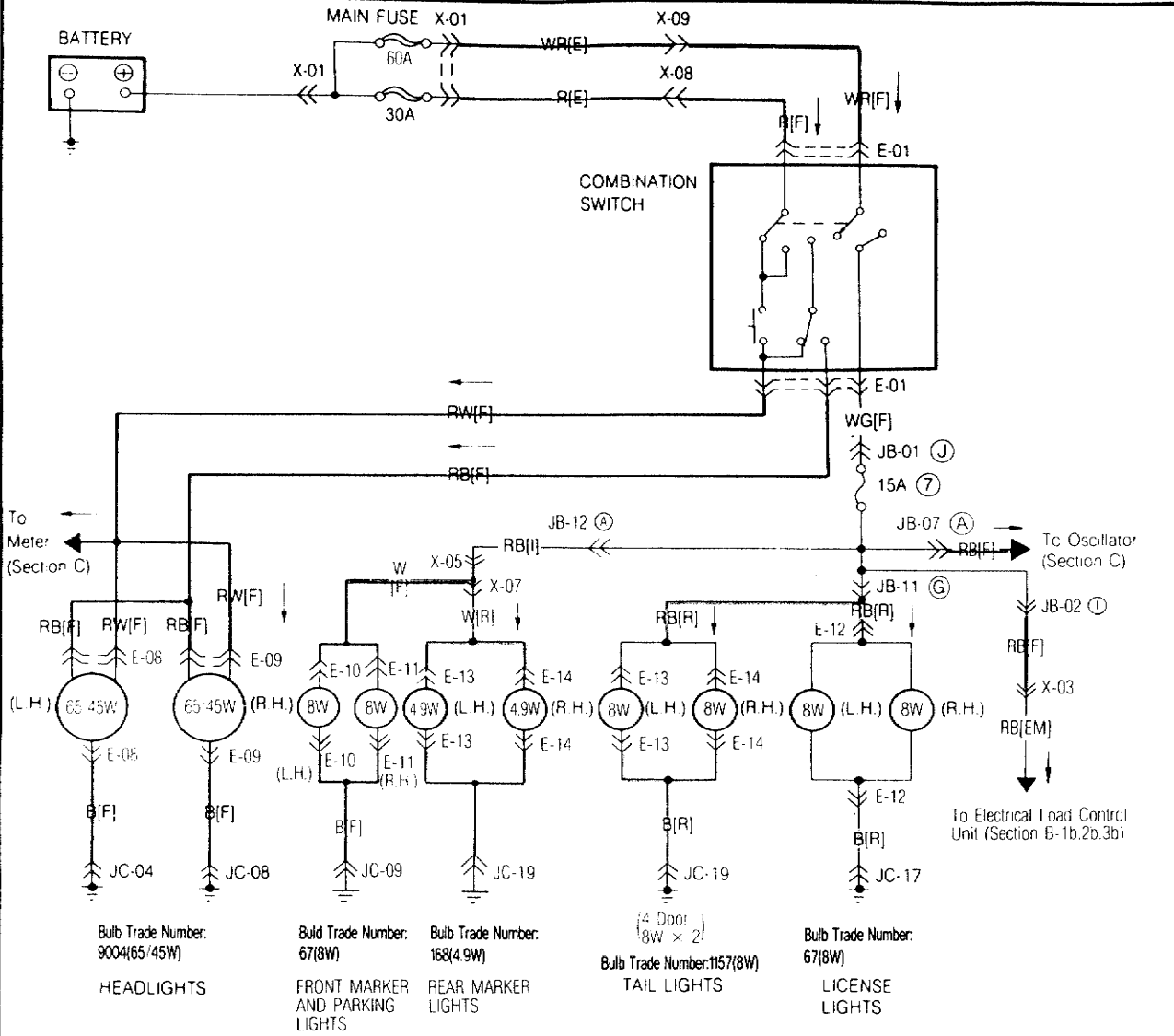

<p>E-01 Combination Switch [F]</p>	<p>E-08 Headlight L.H. [F]</p>	<p>E-09 Headlight R.H. [F]</p>
<p>E-10 F. Comb. Light L.H. [F]</p>	<p>E-11 F. Comb. Light R.H. [F]</p>	<p>E-12 License Light [R]</p>
<p>E-14 R. Comb. Light R.H. [R]</p>		

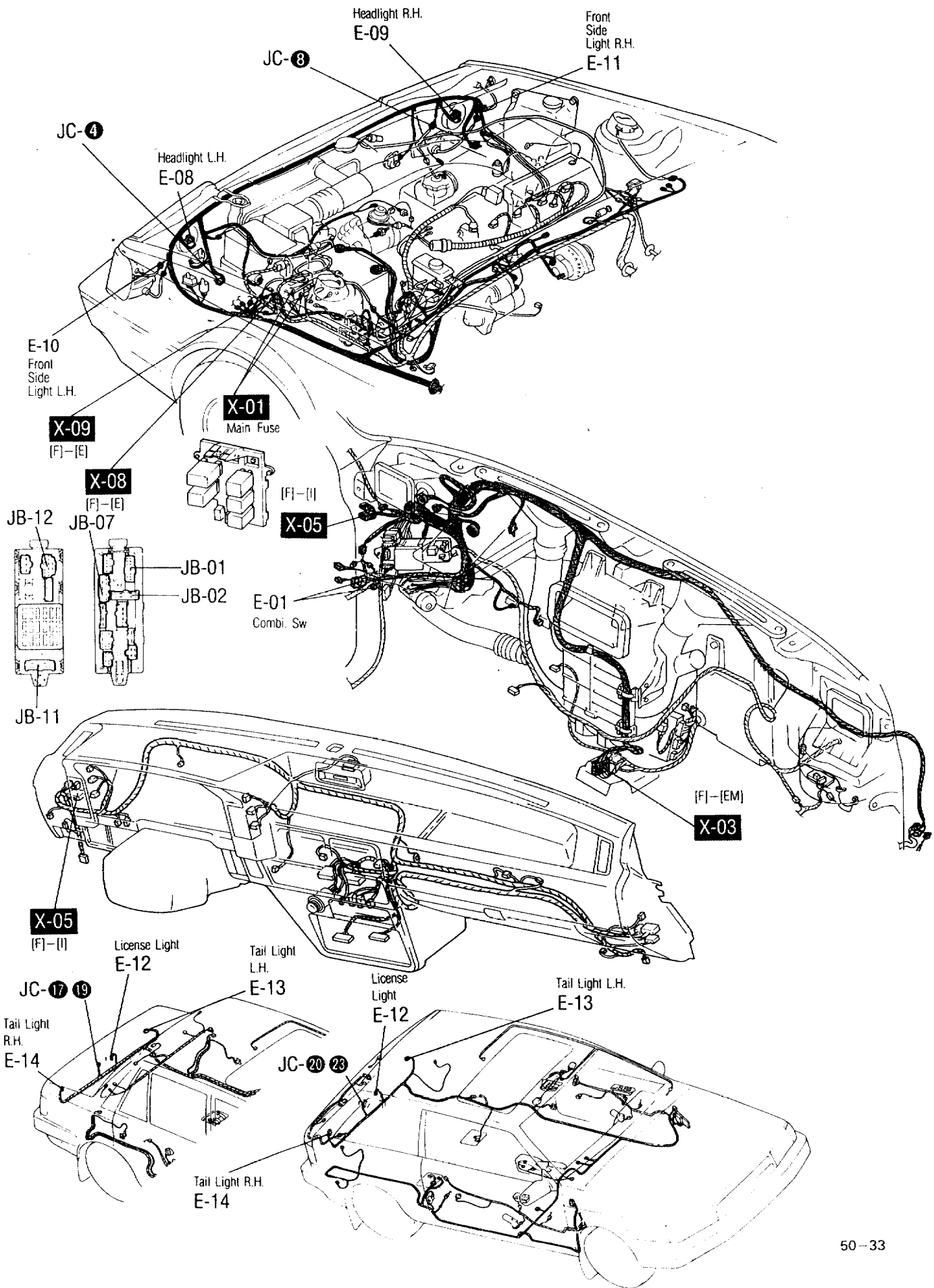

F-a

BACK-UP LIGHTS  
TURN & HAZARD FLASHER LIGHTS

Note: ✕ .... Not Used

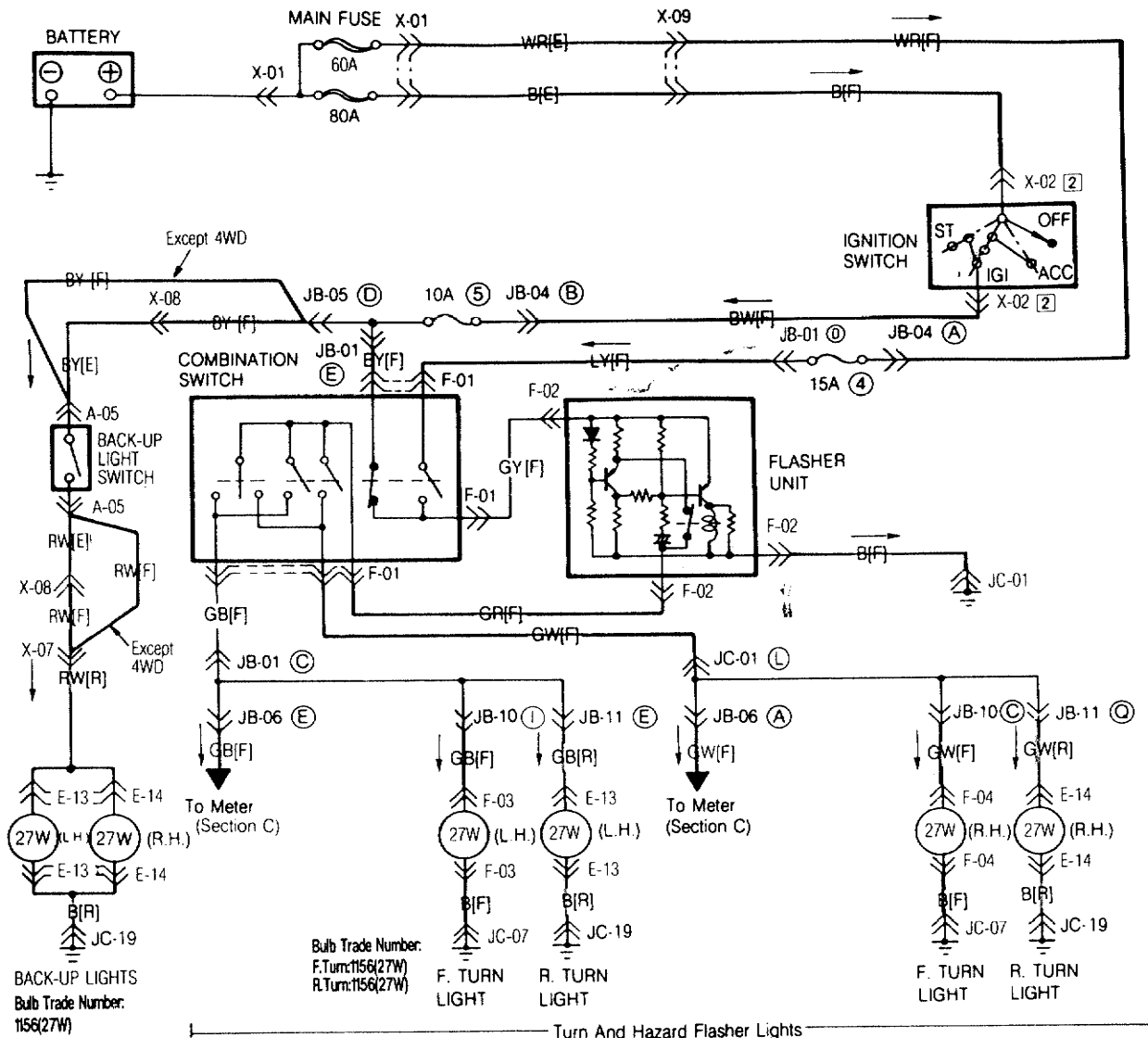

<p>F-01 Combination Switch [F]</p> <p>GB BY GY LY GR GW ✕ ✕</p>	<p>F-02 Flasher Unit [F]</p> <p>B — GY — GR</p>	<p>F-03 Front Turn Light L.H. [F]</p> <p>— GB — B</p>	<p>F-04 Front Turn Light R.H. [F]</p> <p>— GW — B</p>
<p>A-05 Back-Up Light Sw [F], [E]</p> <p>BY BY [F] RW BR</p>	<p>[E]</p> <p>BY BY RW BR (4WD)</p>	<p>E-13 Rear Combi. Light L.H. [R]</p> <p>W RW GB B RB G</p>	<p>E-14 Rear Combi. Light R.H. [R]</p> <p>W RW GW B RB G</p>

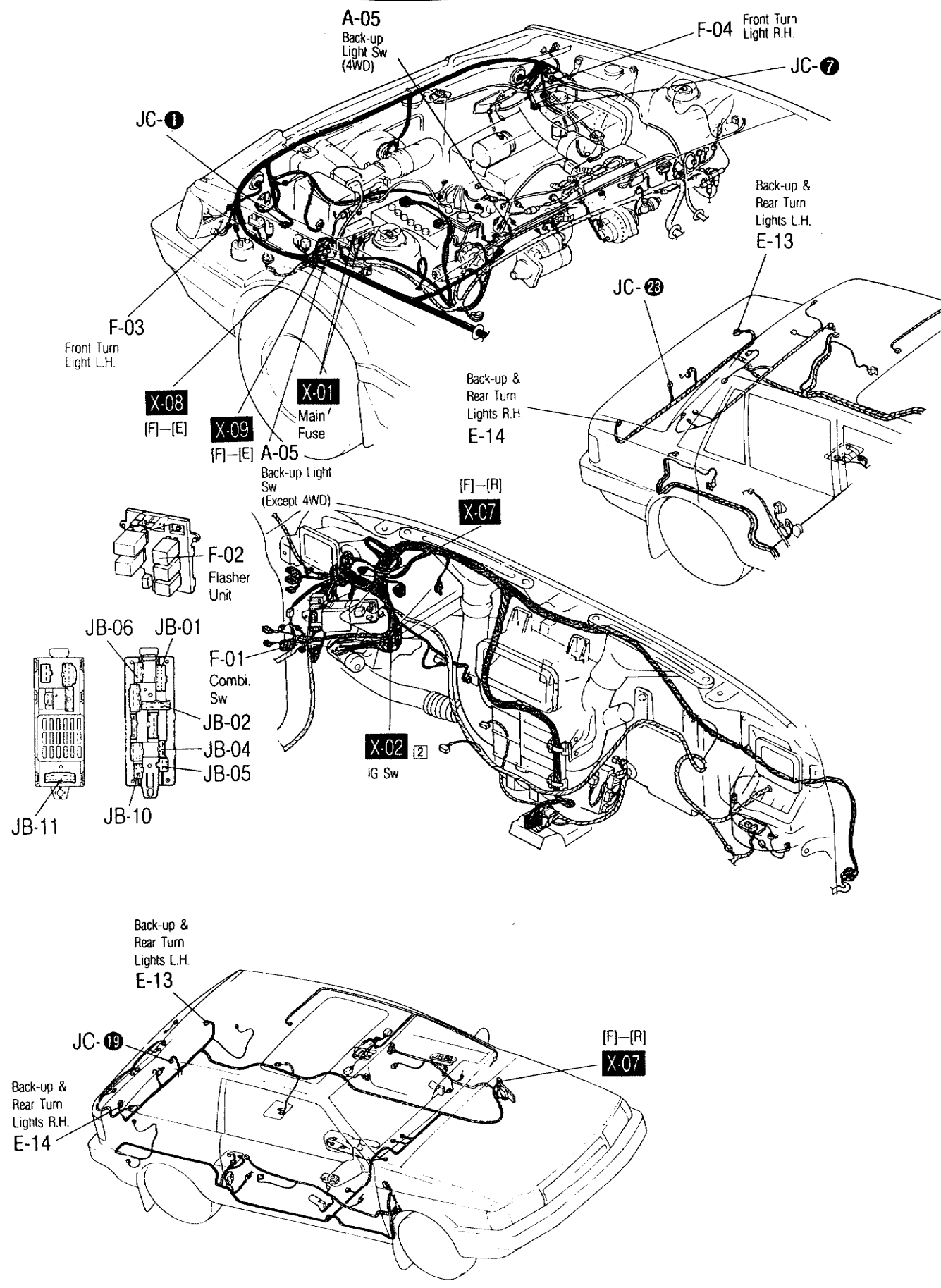

# F-b ■ HORN ■ STOP LIGHTS

Note: \* ... Not Used

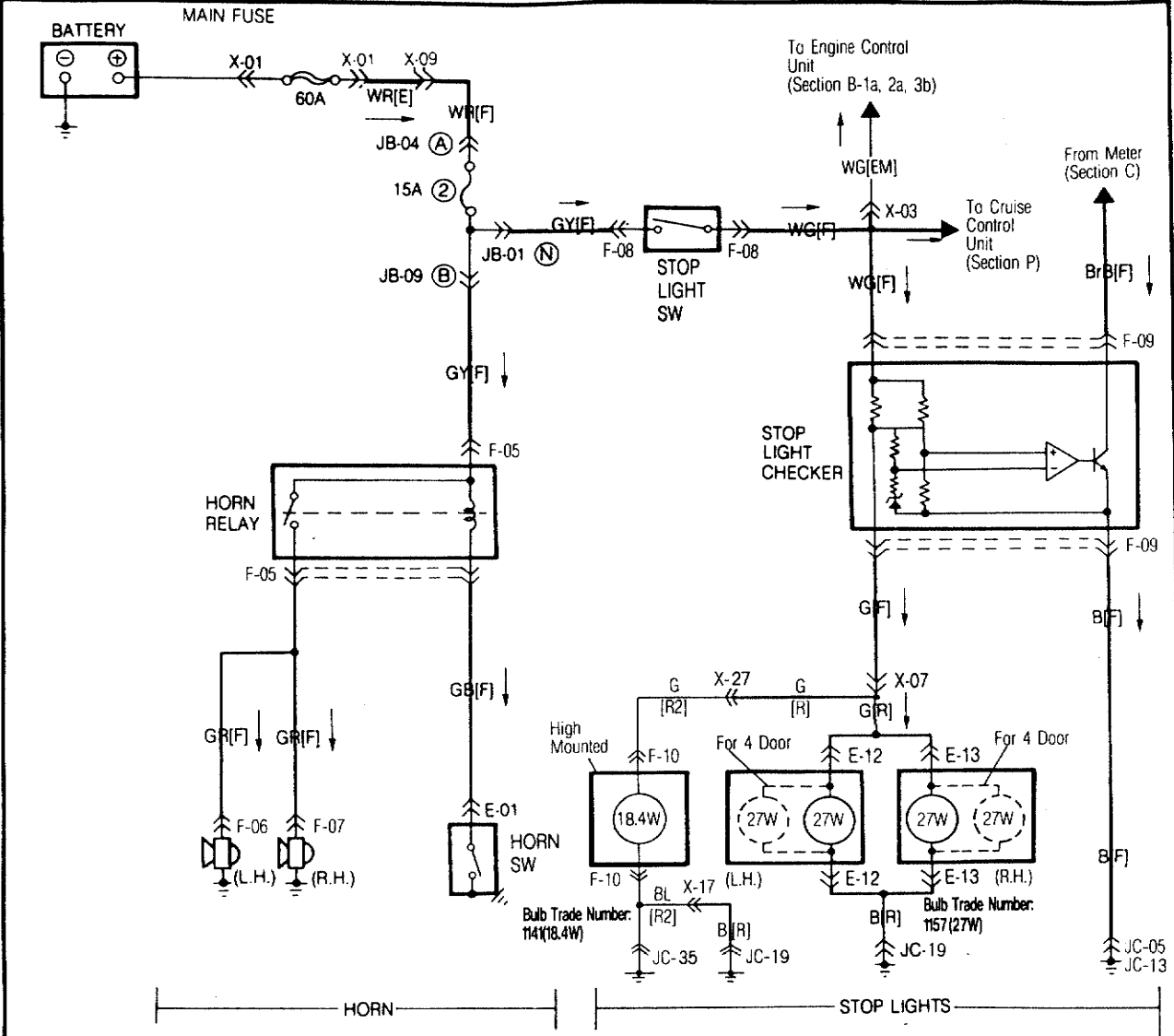

<p>F-05 Horn Relay [F]</p>	<p>F-06 Horn L.H. [F]</p>	<p>F-07 Horn R.H. [F]</p>	<p>F-08 Stop Light Sw [F]</p>
<p>F-09 Stop Light Checker [F]</p>	<p>F-10 High Mounted Stop Light [R2]</p>	<p>E-01 Combination Sw [F]</p>	<p>E-13 R. Combi. Light L.H. [R]</p>
<p>E-14 R. Combi. Light R.H. [R]</p>			



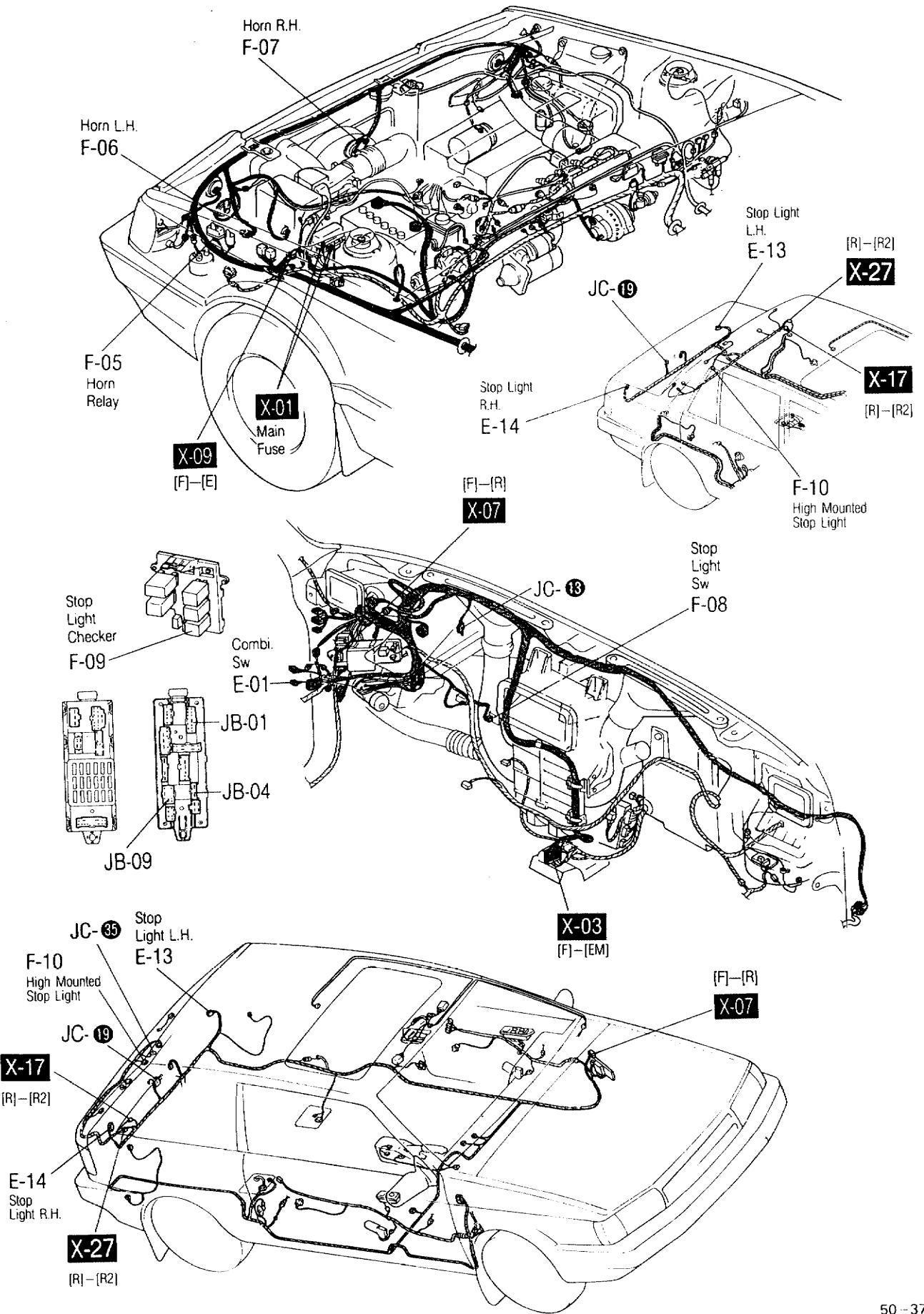







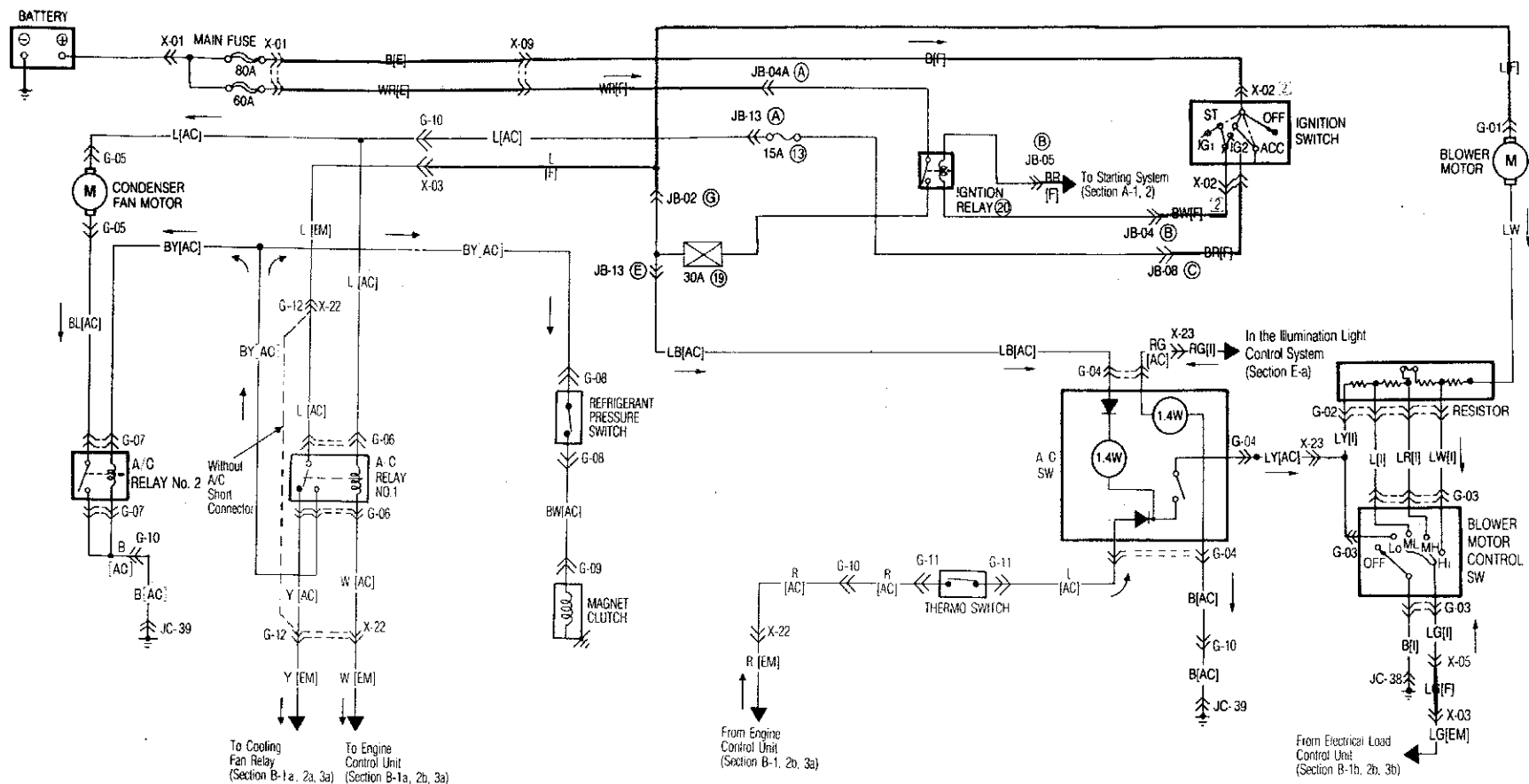





**G**

**AIR CONDITIONER & HEATER**

Note: x ... Not Used



<p><b>G-01 Blower Motor [F]</b></p> 	<p><b>G-02 Resistor [I]</b></p> 	<p><b>G-03 Blower Motor Control Sw [I]</b></p> 	<p><b>G-04 A/C Switch [AC]</b></p> 	<p><b>G-05 Condenser Fan Motor [AC]</b></p> 	<p><b>G-06 A C Relay No.1 [AC]</b></p> 	<p><b>G-07 A C Relay No.2 [AC]</b></p> 	<p><b>G-08 Refrigerant Pressure Switch</b></p> 
<p><b>G-09 Magnet Clutch [AC]</b></p> 	<p><b>G-10 Connector Between Air Con. [AC] And Air Con. [AC] Harness</b></p> 		<p><b>G-11 Thermo Switch [AC]</b></p> 	<p><b>G-12 Short Connector</b></p>  <p>Without A/C</p>			

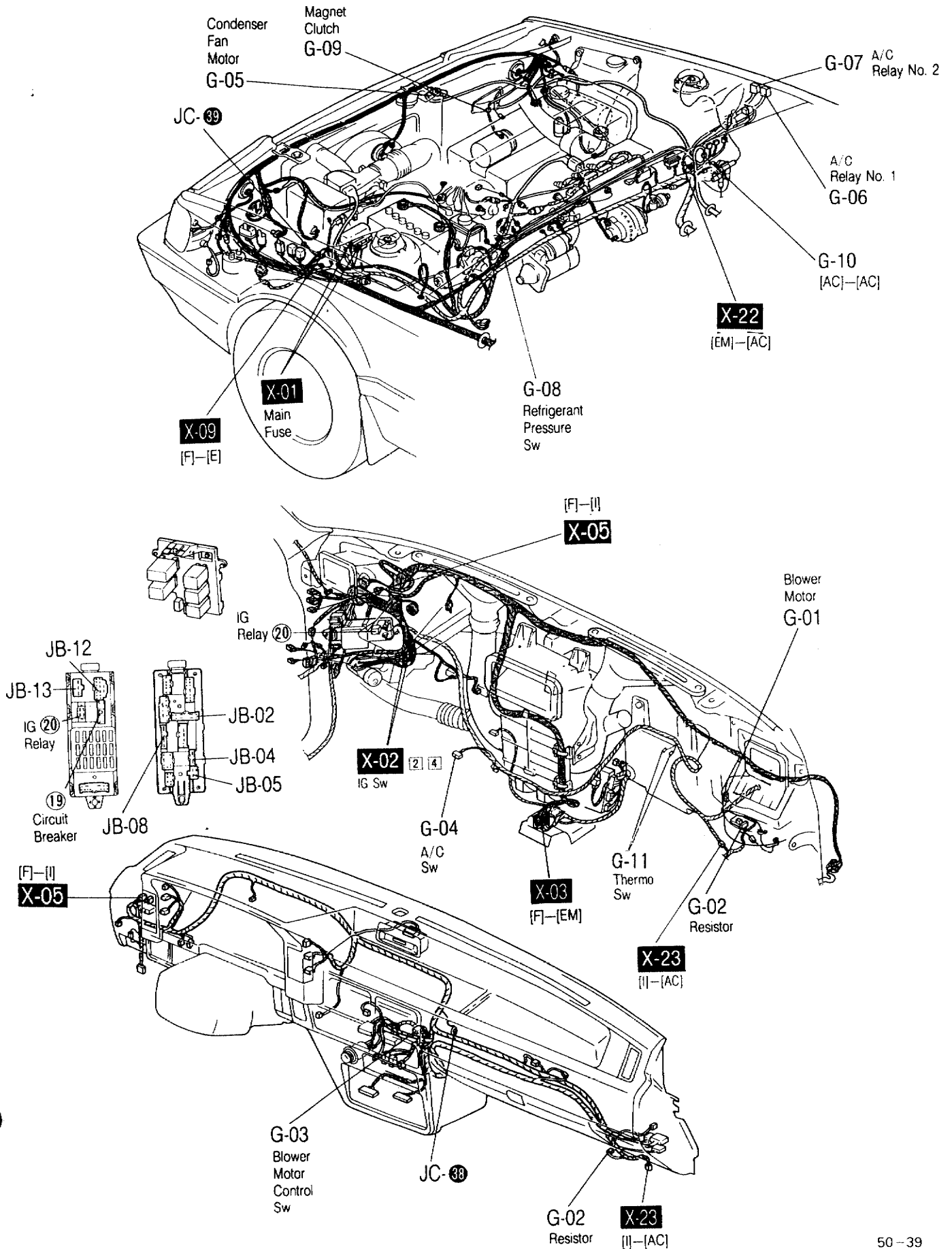

# H

## ■ CIGARETTE LIGHTER

Note:  
✕ ...Not Used

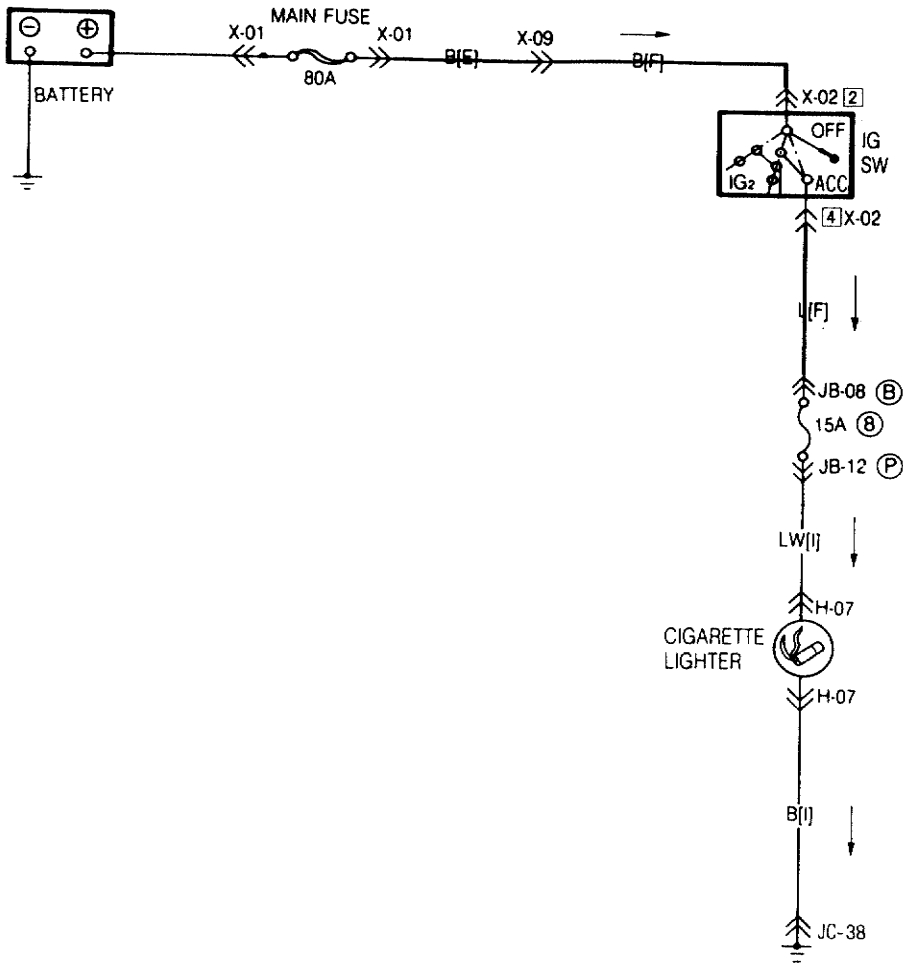

H-01 Cigarette Lighter [I]



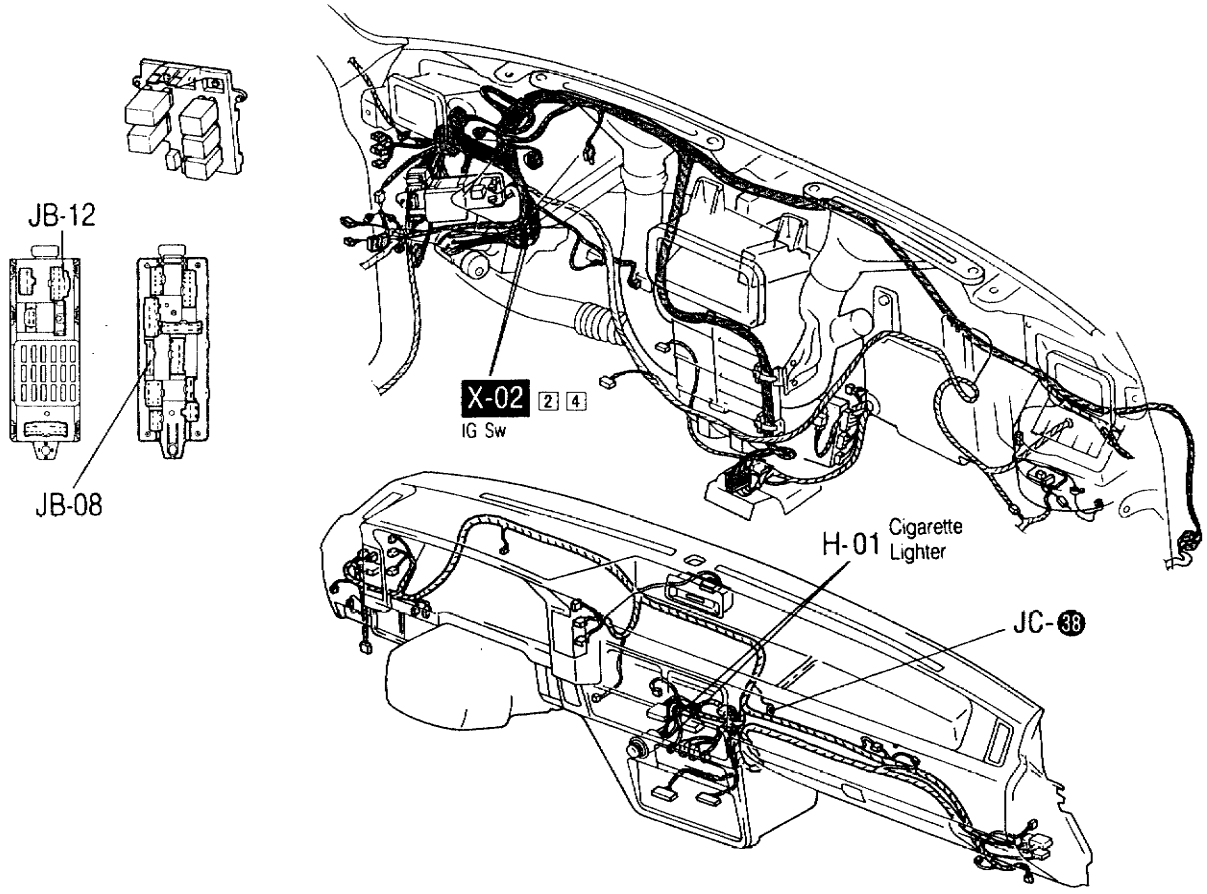
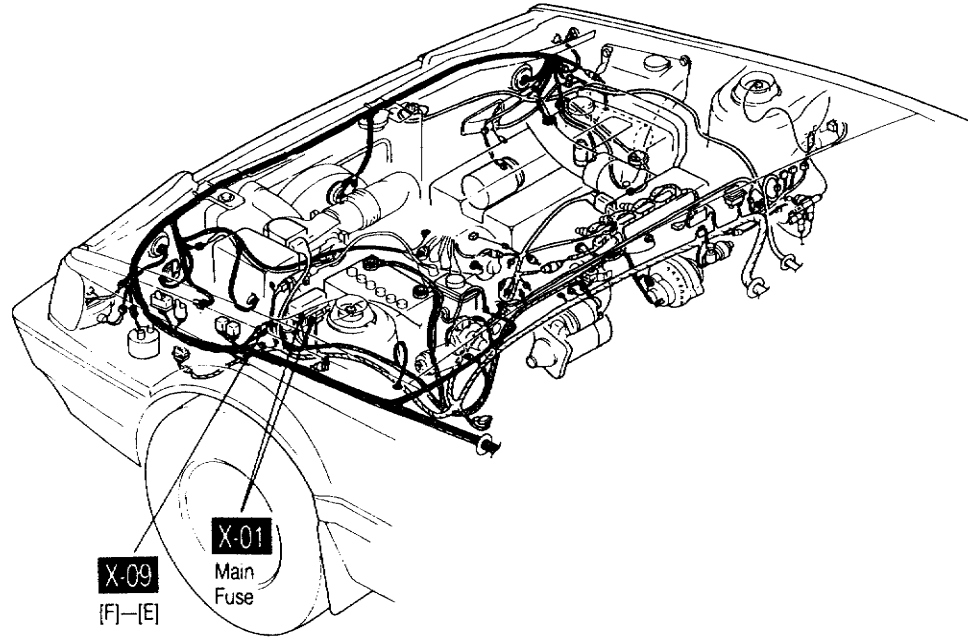



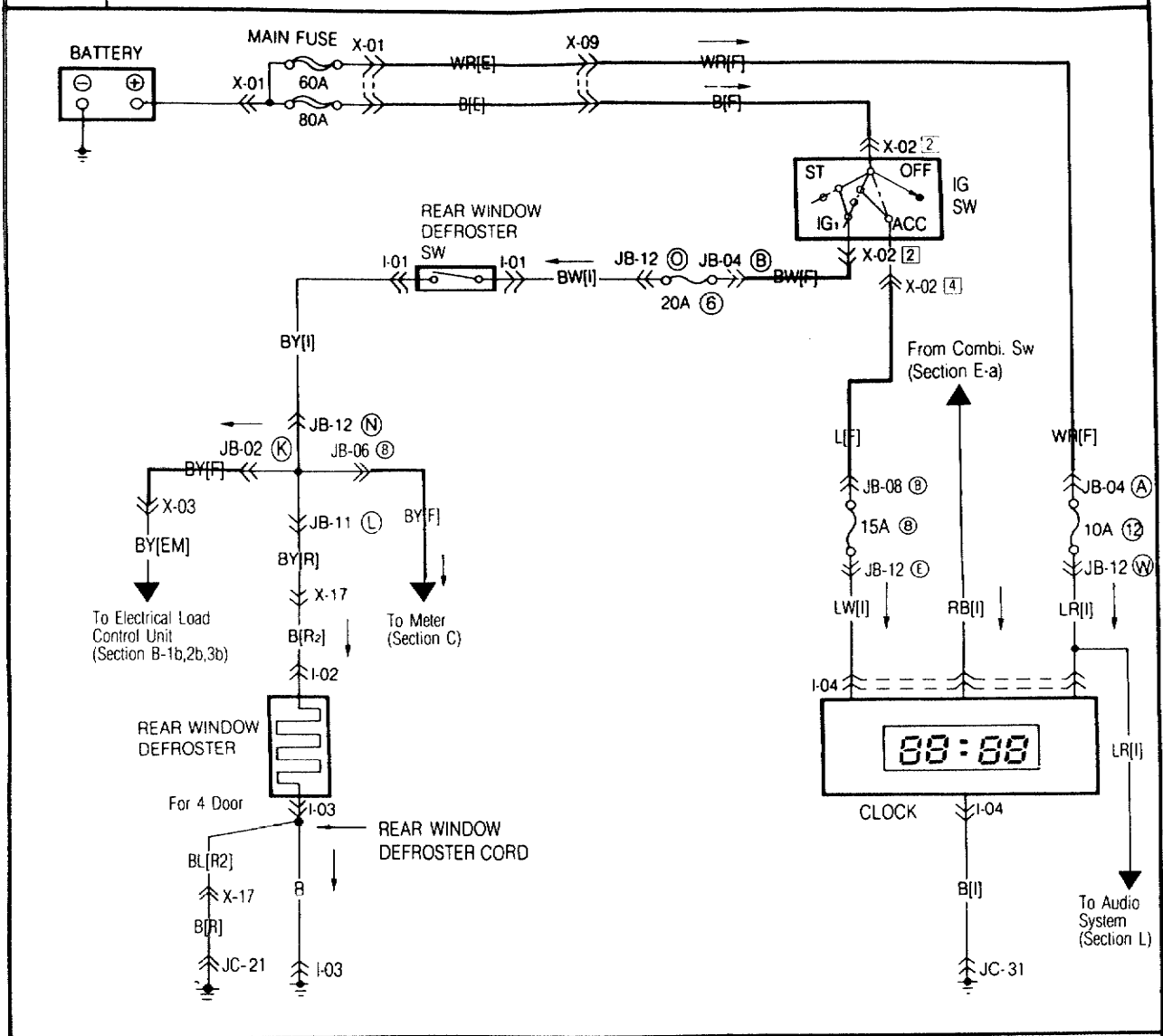

# DIGITAL CLOCK ■ REAR WINDOW DEFROSTER

Note:  
\* ... Not Used

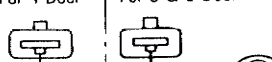

<p>I-01 Rear Window Def. Sw [I]</p> 	<p>I-02 Rear Window Def. [R<sub>2</sub>]</p> 	<p>I-03 Rear Window Def. Cord For 4 Door      For 3 &amp; 5 Door</p> 	<p>I-04 Clock [I]</p> 

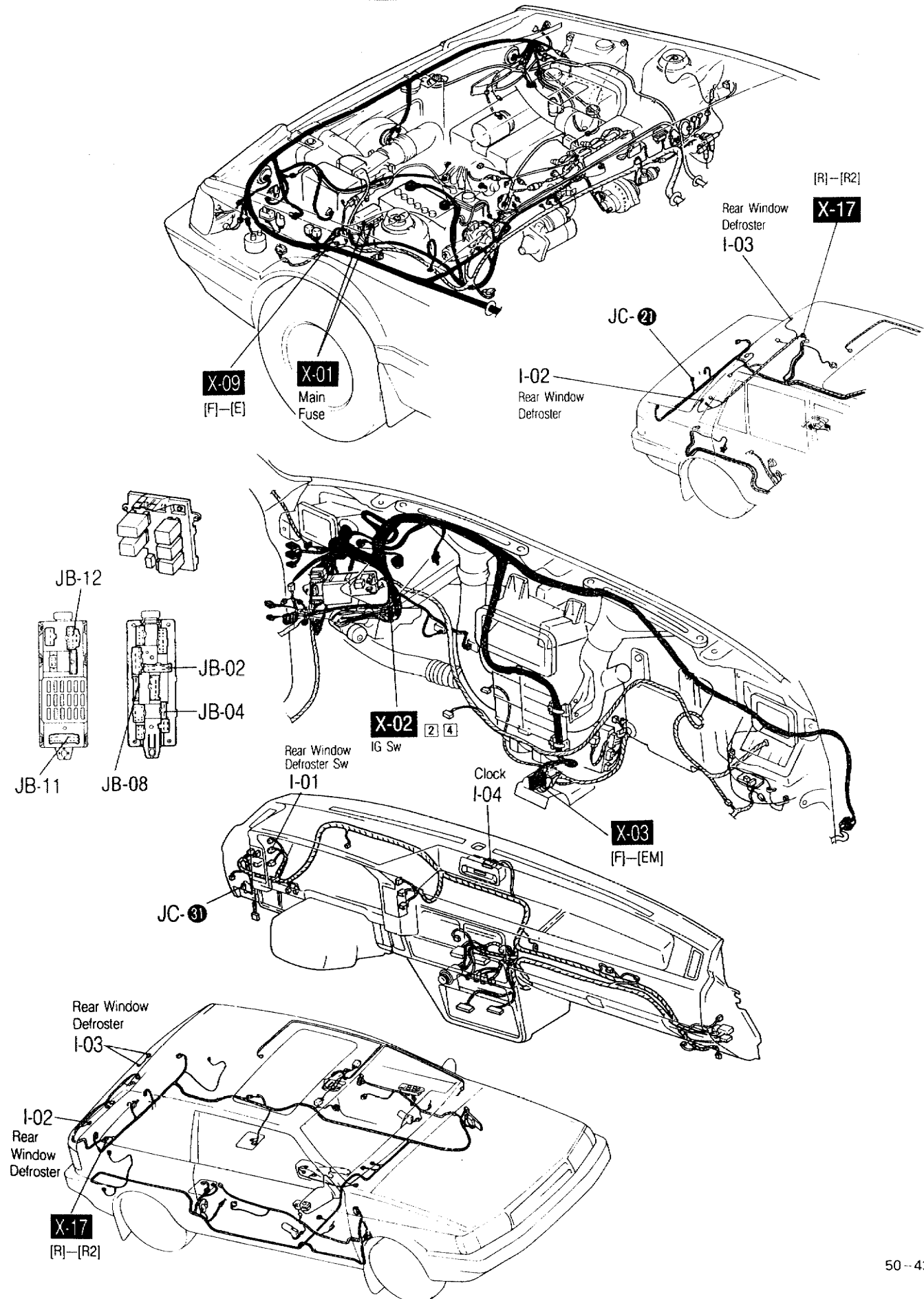

**J ■ COURTESY LIGHTS ■ DOOR LOCK CYLINDER LIGHT ■ IGNITION KEY CYLINDER LIGHT ■ INTERIOR & SPOT LIGHTS**  
**■ LUGGAGE COMPARTMENT LIGHT ■ SEAT BELT WARNING SYSTEM**

Note: \* Not Used

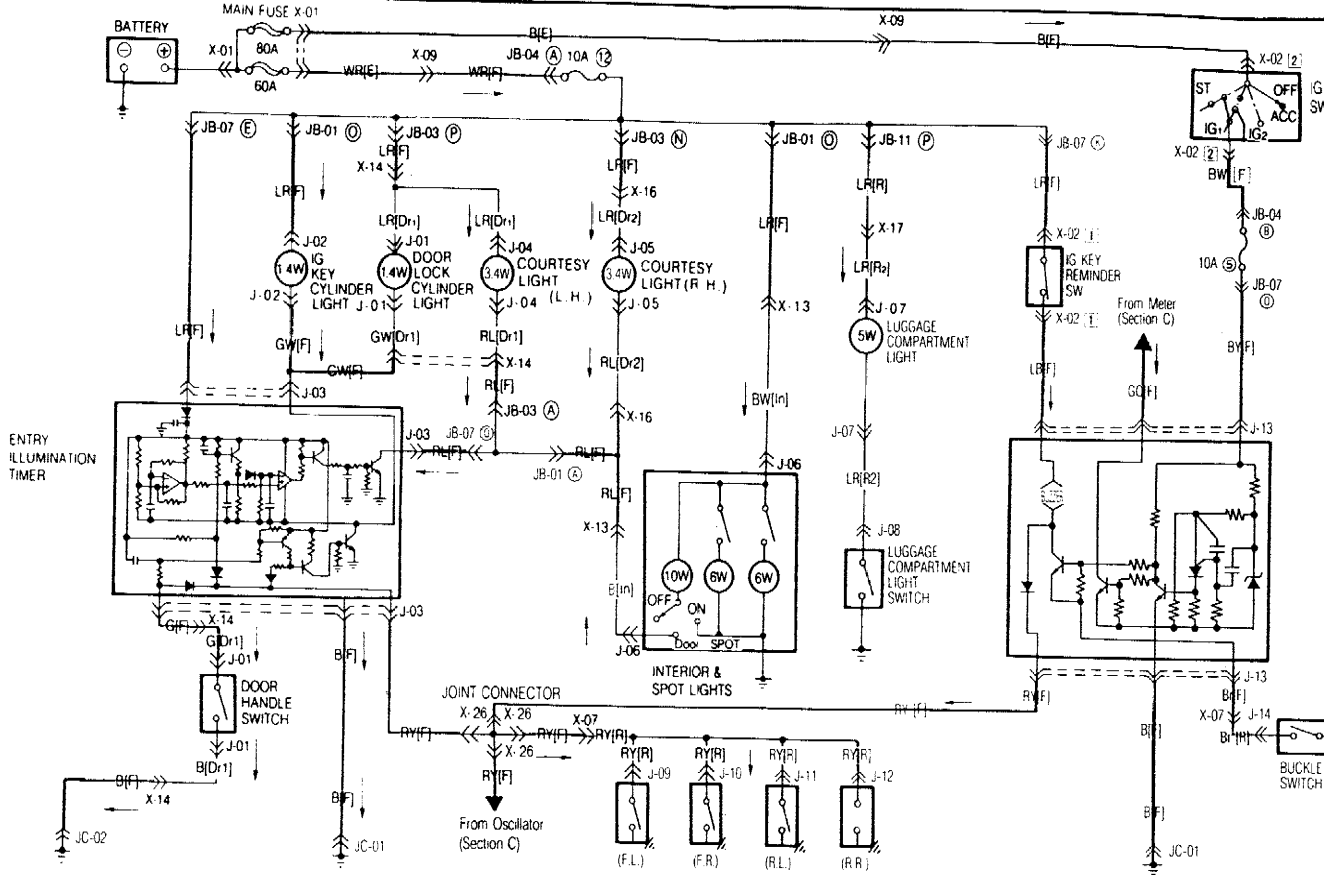

<p>J-01 Door Lock Cylinder Light &amp; Door Handle Sw [Dr1]</p>	<p>J-02 IG Key Cylinder Light [F]</p>	<p>J-03 Entry Illumination Timer [F]</p>	<p>J-04 Courtesy Light [Dr1]</p>	<p>J-05 Courtesy Light [Dr2]</p>	<p>J-06 Interior &amp; Spot Lights [In]</p>	<p>J-07 Luggage Compartment Light [R2]</p>	<p>J-08 Luggage Compartment Light Switch [R2]</p>	<p>J-09 Door Switch F.L. [R]</p>	<p>J-10 Door Switch F.R. [R]</p>	<p>J-11 Door Switch R.L. [R]</p>	<p>J-12 Door Switch R.R. [R]</p>	<p>J-13 Timer And Buzzer [F]</p>	<p>J-14 Buckle Switch [R]</p>
---	---------------------------------------	--	----------------------------------	----------------------------------	---	--	---	----------------------------------	----------------------------------	----------------------------------	----------------------------------	----------------------------------	-------------------------------



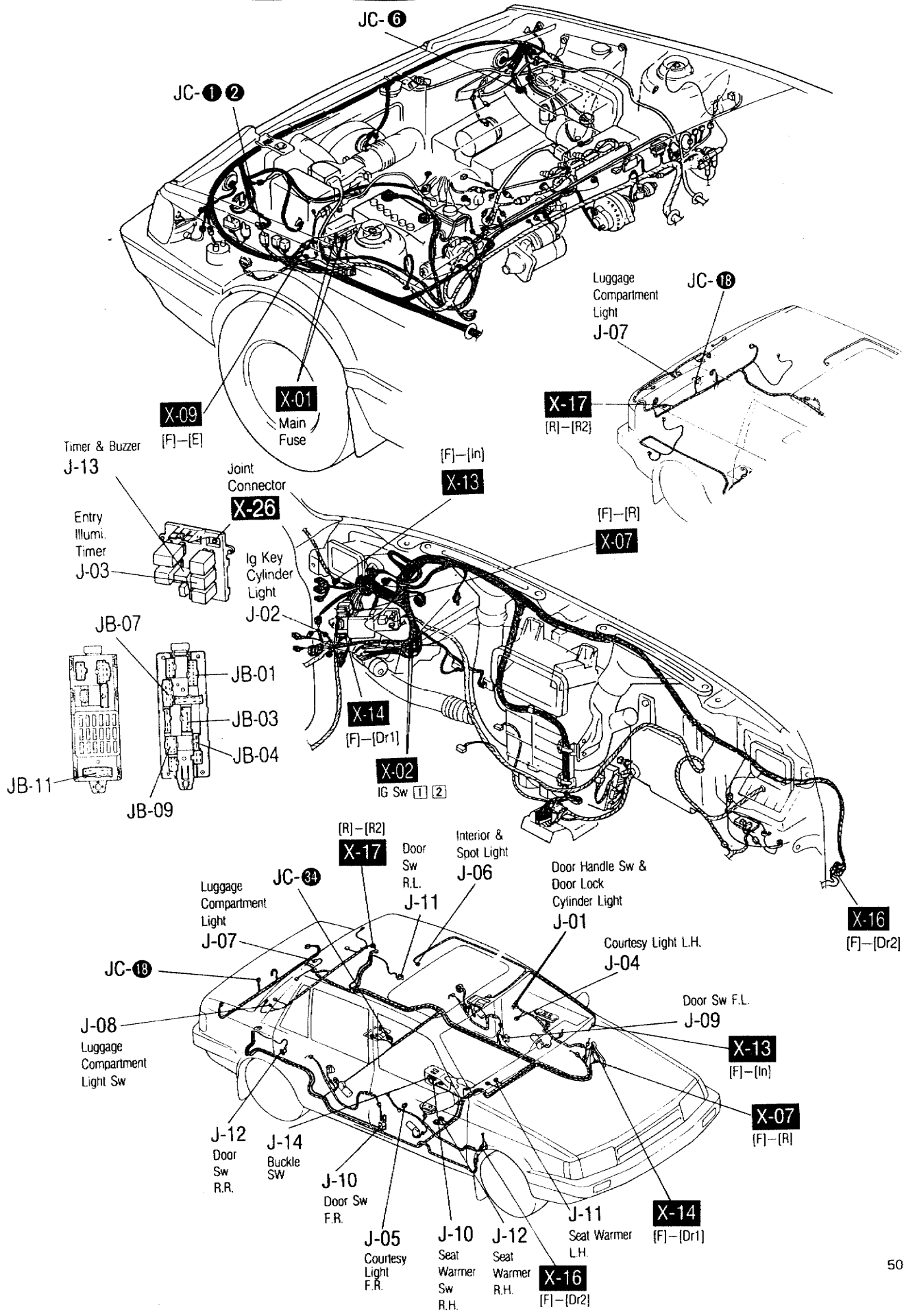

# K ■ POWER WINDOW

Note:  
 < > .. For 3 Door  
 ✕ .. Not Used

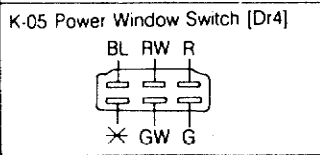
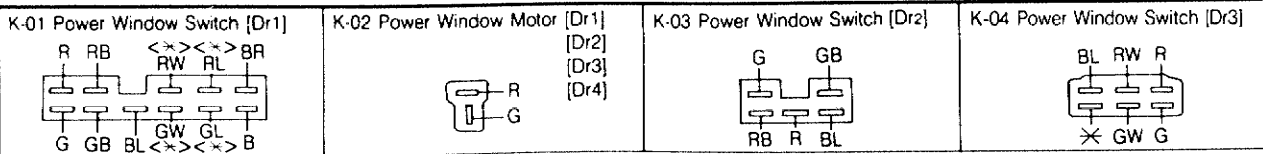
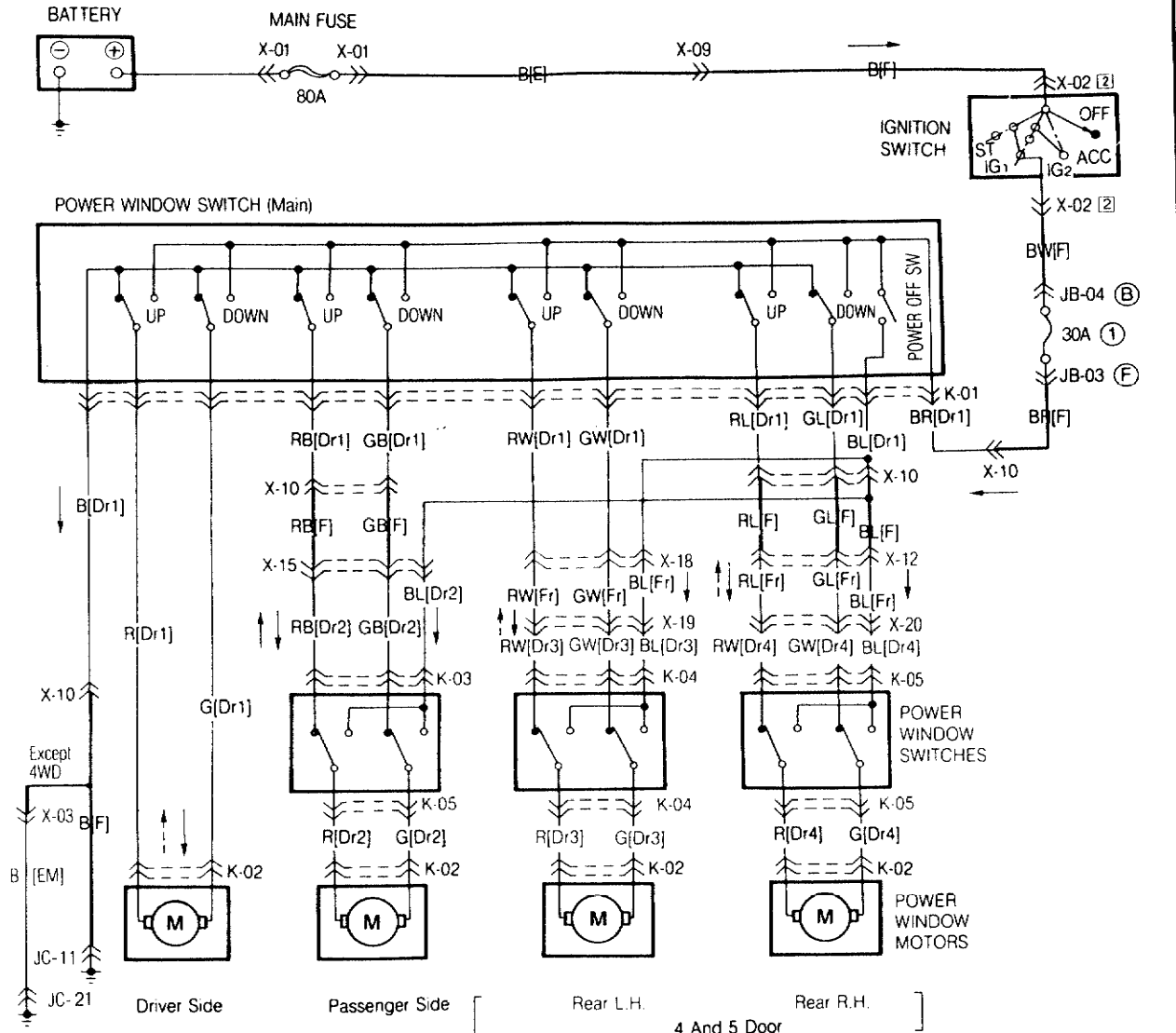

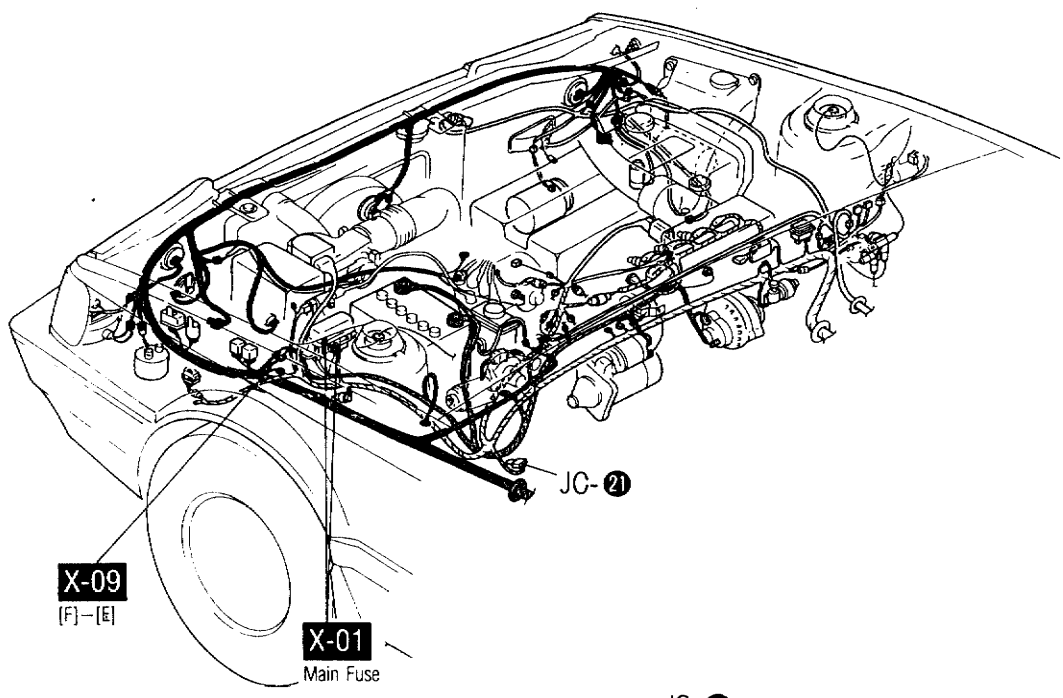
X-09  
(F)-[E]

X-01  
Main Fuse

JC-21

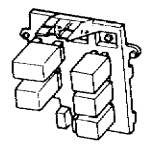

X-10  
(F)-[Dr1]

X-18  
(Dr1)-[Fr]

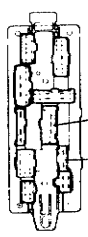
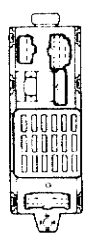

JB-03

JB-04

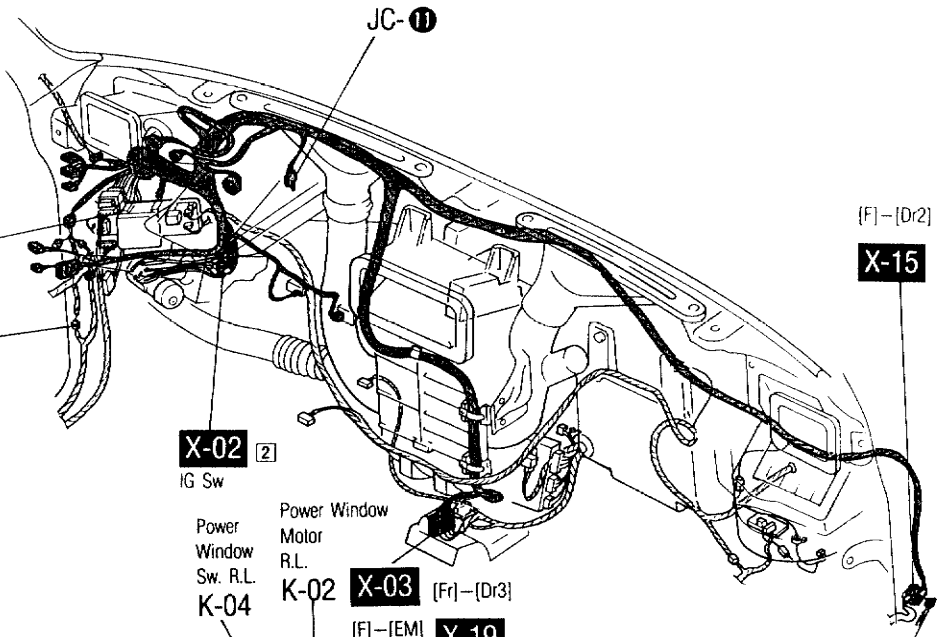

JC-11

(F)-[Dr2]

X-15

X-02 2  
IG Sw

Power Window Motor R.L.  
K-04

Power Window Sw. R.L.  
K-02

X-03 (Fr)-[Dr3]  
(F)-[EM] X-19

Power Window Main Sw  
K-01

Power Window Motor F.L.  
K-02

X-12  
(F)-[Fr]

K-05  
Power Window Sw R.R.

X-10  
(F)-[Dr1]

K-02  
Power Window Motor R.R.

X-20  
(F)-[Dr4]

K-03  
Power Window Sw F.R.

K-02  
Power Window Motor F.R.

X-12  
(F)-[Fr]

X-15  
(F)-[Dr2]

X-18  
(Fr)-[Dr1]



TYPE 1

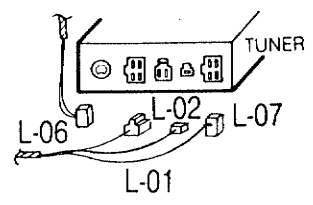

TYPE 2

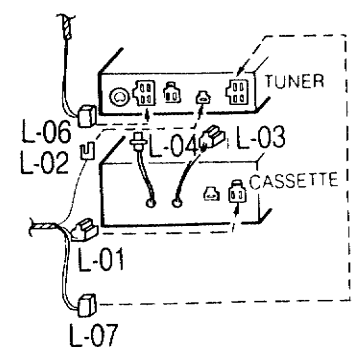

JB-12

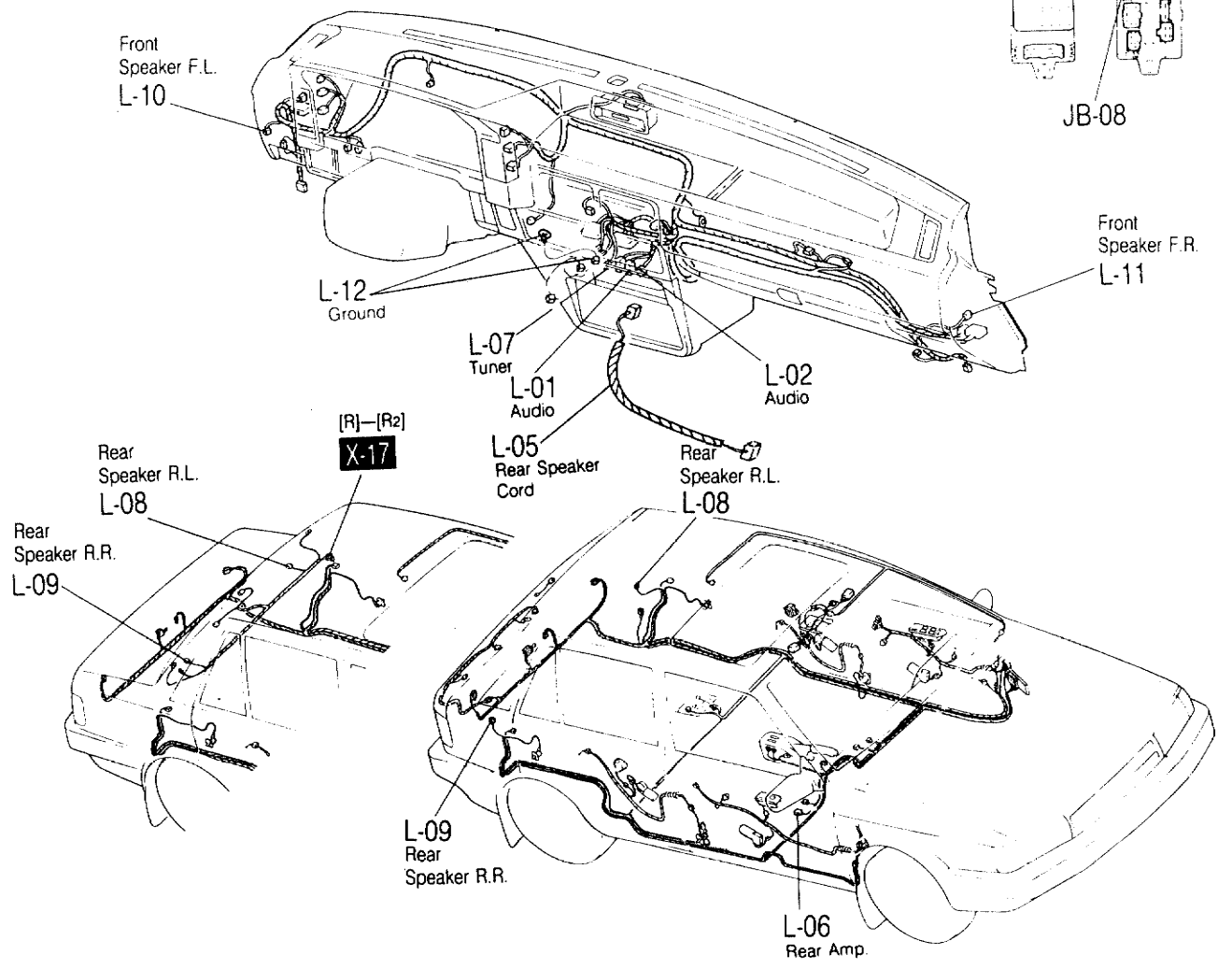
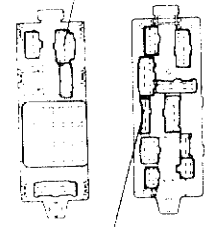

**M**

**REMOTE CONTROL MIRROR**

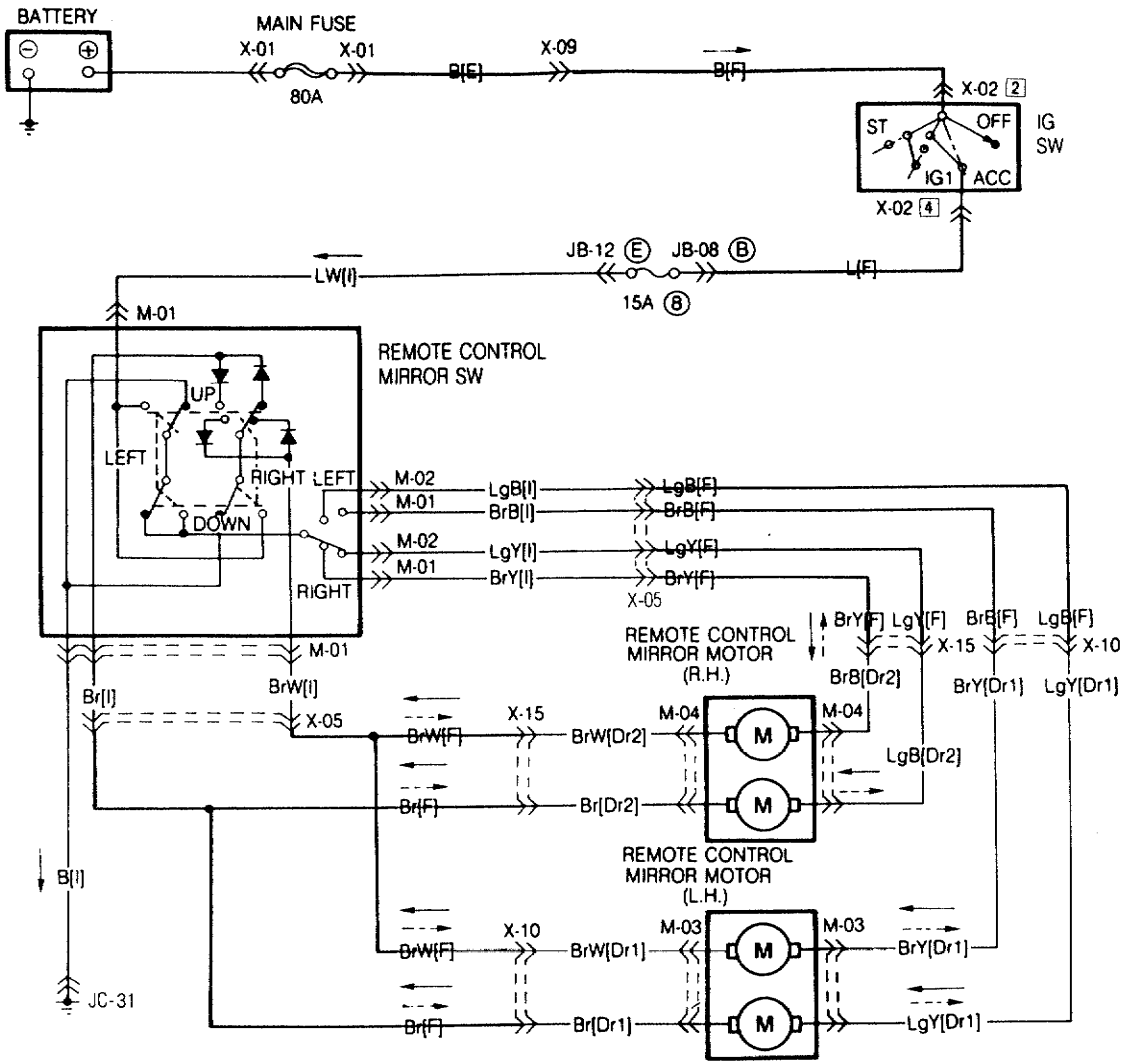

M-01 Remote Control Mirror Sw [I]

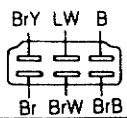

M-02 Remote Control Mirror Sw [I]

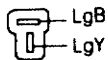

M-03 Remote Control Mirror Motor L.H. [Dr1]

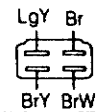

M-04 Remote Control Mirror Motor R.H. [Dr2]

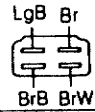

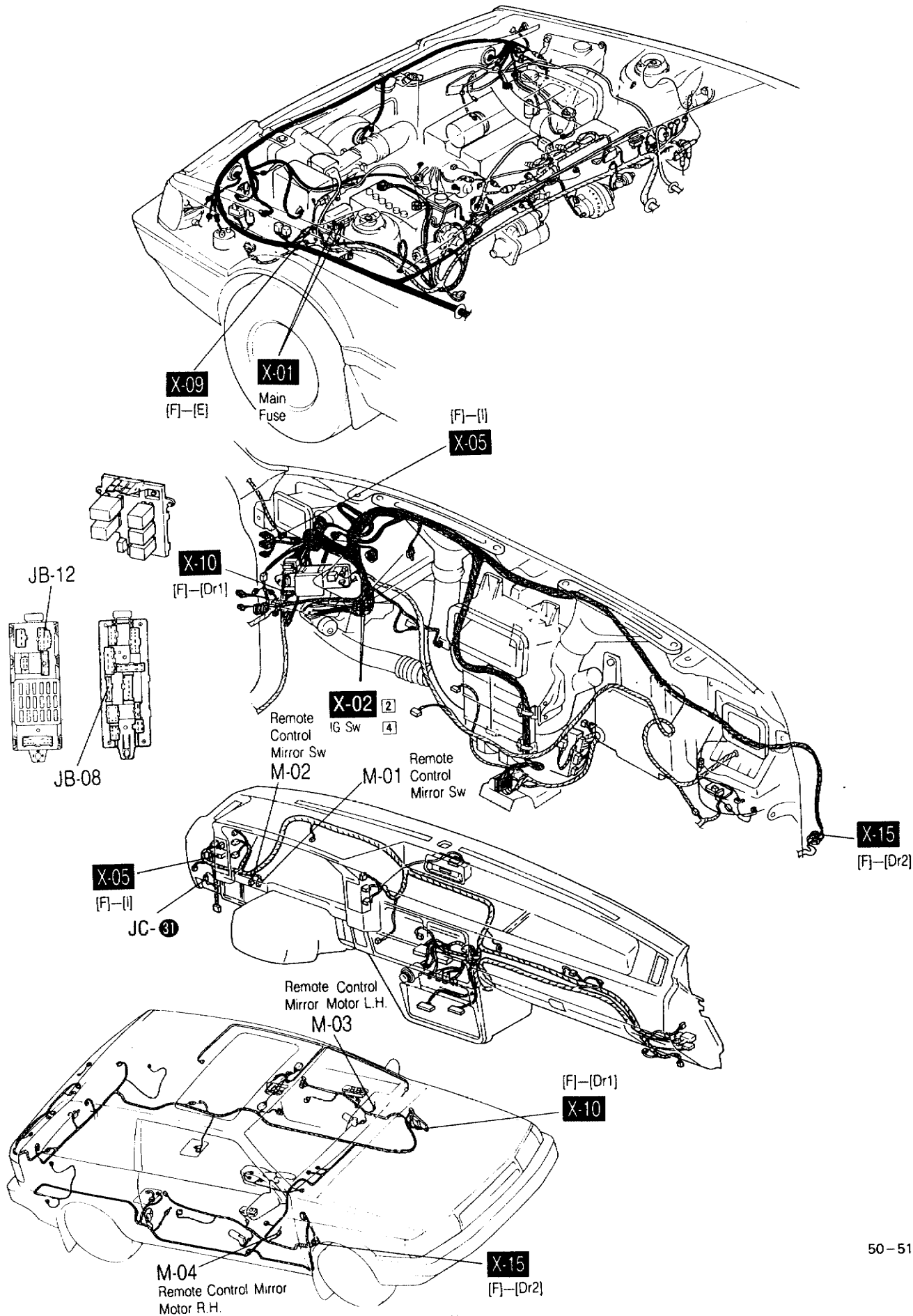





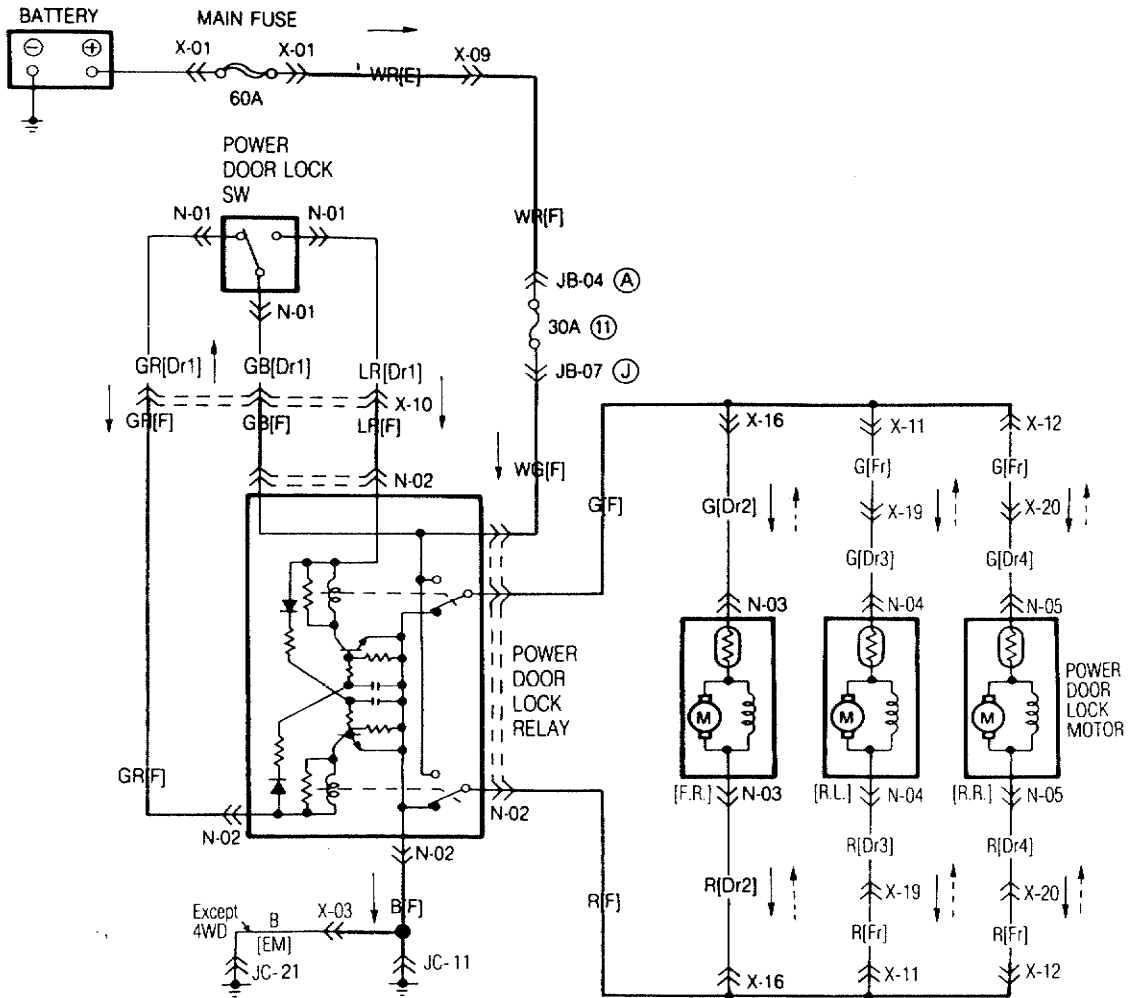

**N**

**POWER DOOR LOCK**

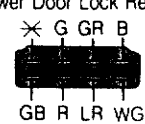
Note: \* ... Not Used



<p>N-01 Power Door Lock Switch [Dr1]</p> 	<p>N-02 Power Door Lock Relay [F]</p> 	<p>N-03 Power Door Lock Motor F.R. [Dr2]</p> 	<p>N-04 Power Door Lock Motor R.L. [Dr3]</p> 
<p>N-05 Power Door Lock Motor R.R. [Dr4]</p> 			



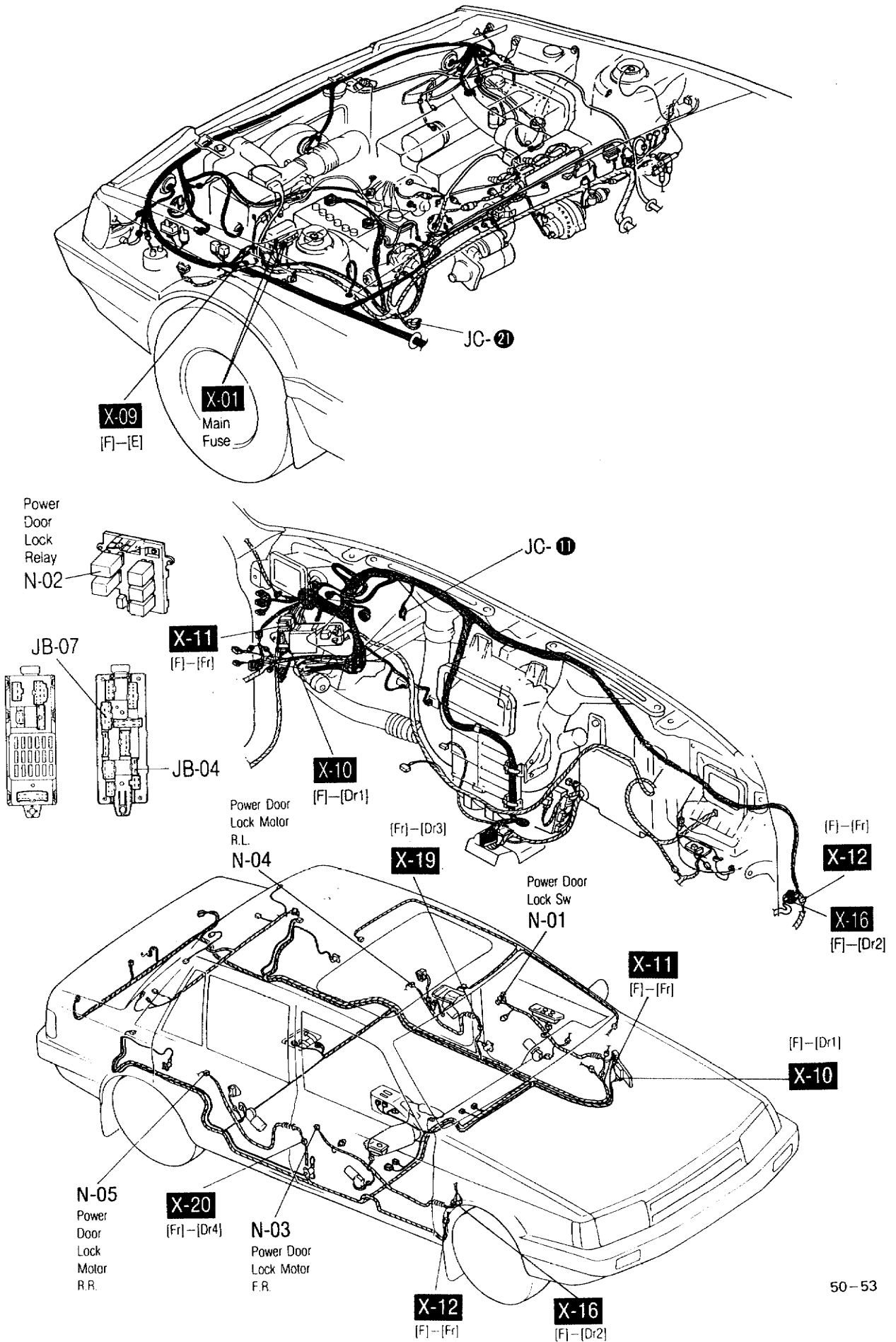

0

ADJUSTABLE SHOCK ABSORBER

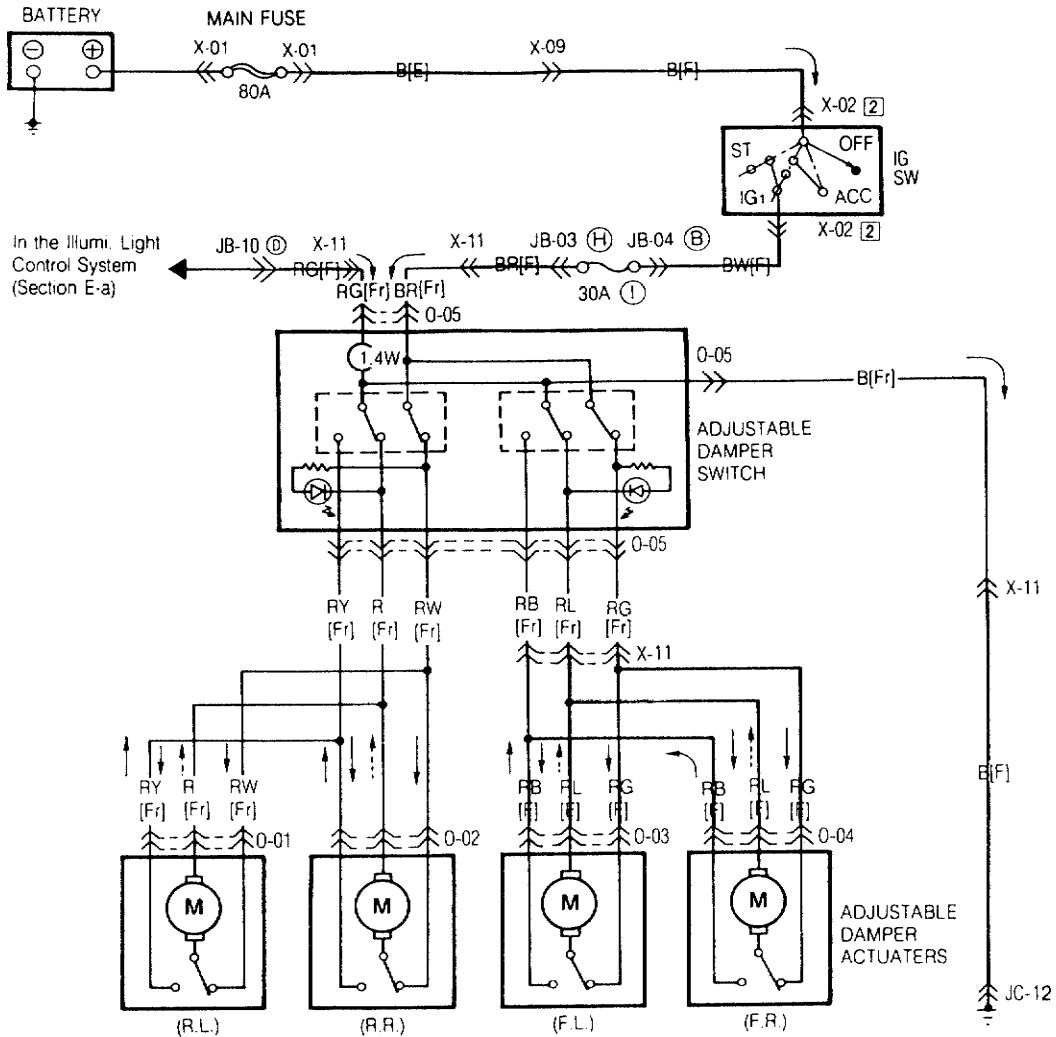

<p>0-01 Adjustable Damper Actuator R.L. [Fr]</p>	<p>0-02 Adjustable Damper Actuator R.R. [Fr]</p>	<p>0-03 Adjustable Damper Actuator F.L.[F]</p>	<p>0-04 Adjustable Damper Actuator F.R.[F]</p>				
<p>0-05 Adjustable Damper Switch [Fr]</p>							

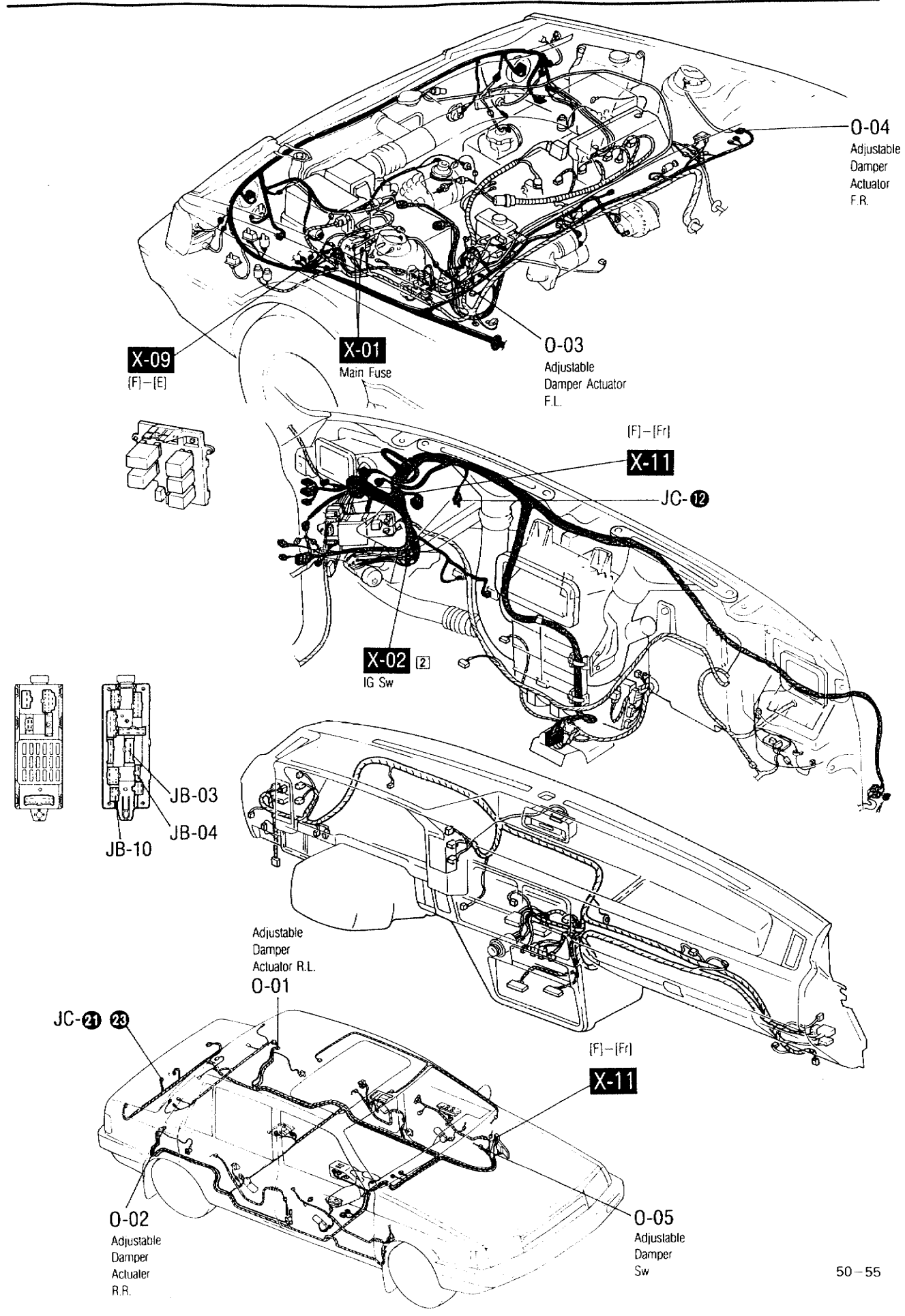

P-1

For Non Turbo  
**CRUISE CONTROL SYSTEM**

Note: ...Not Used

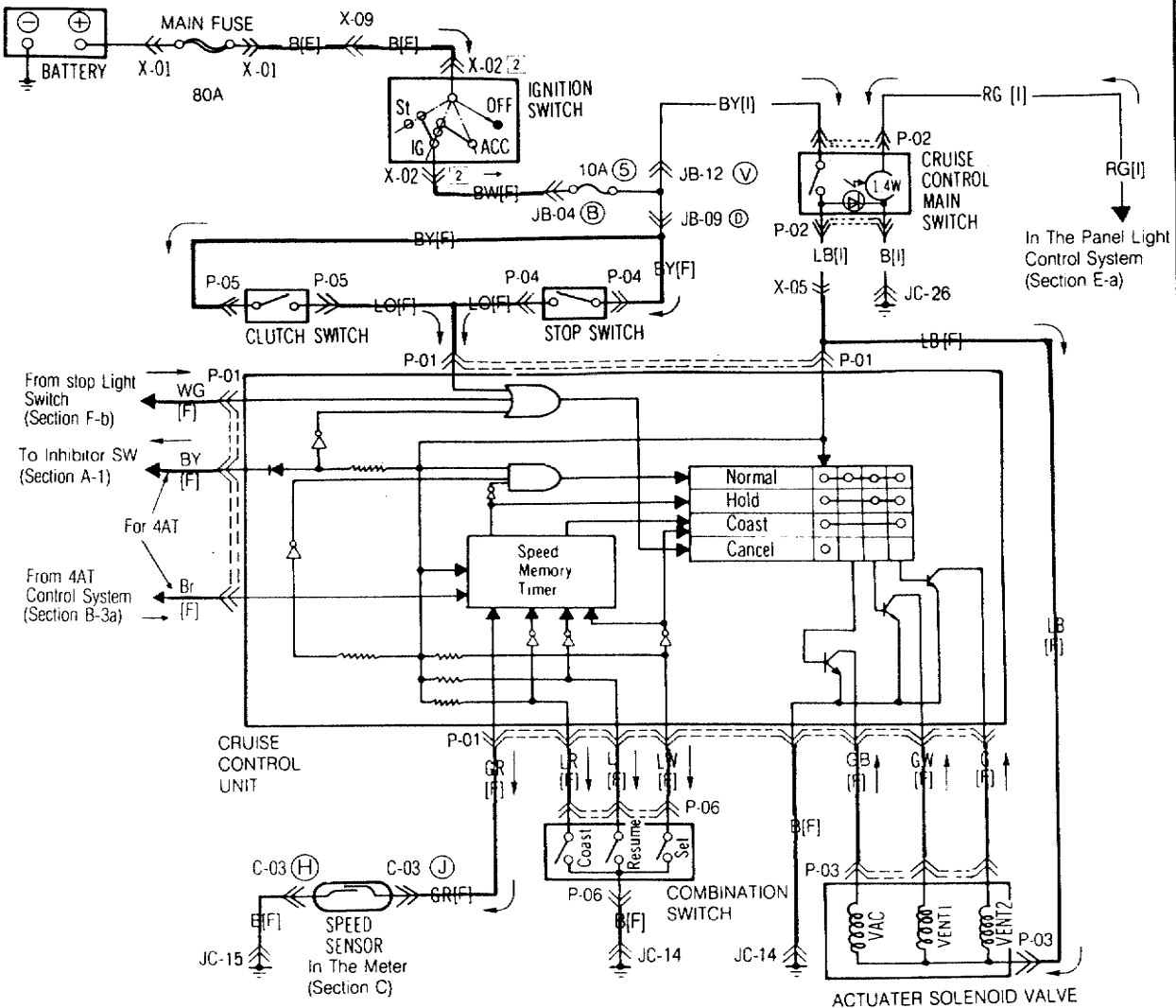

<p>P-01 Cruise Control Unit [F] ( ) ... 4AT</p>	<p>P-02 Cruise Control Main Switch [I]</p>	<p>P-03 Actuator Solenoid Valve [F]</p>	
<p>P-04 Stop Switch [F]</p>	<p>P-05 Clutch Switch [F]</p>	<p>P-06 Combination Switch [F]</p>	

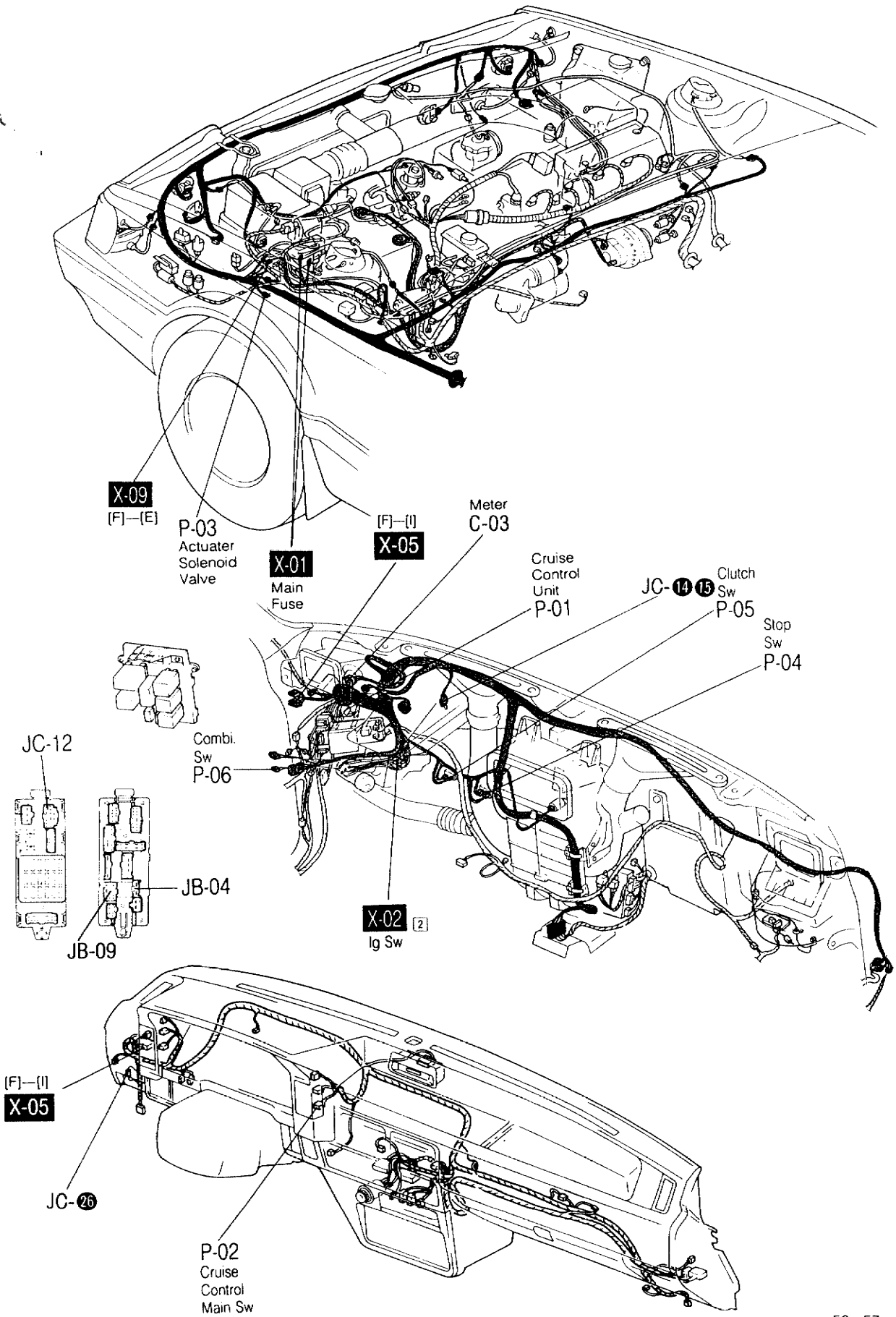

P-2

For Turbo without 4WD  
**CRUISE CONTROL SYSTEM**

Note: ...Not Used

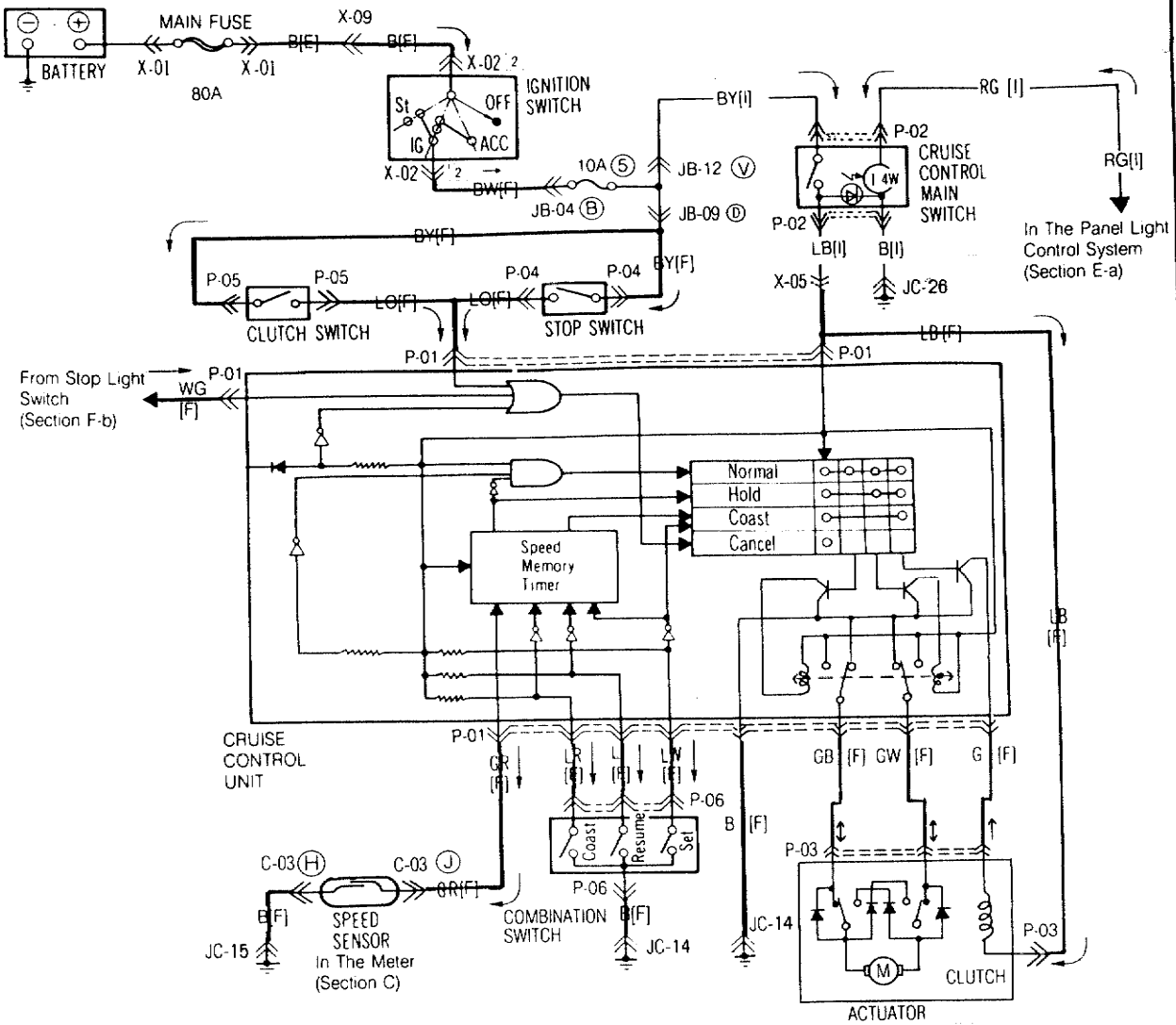

<p>P-01 Cruise Control Unit [F]</p>	<p>P-02 Cruise Control Main Switch [I] (E-05)</p>	<p>P-03 Actuator [F]</p>	
<p>P-04 Stop Switch [F]</p>	<p>P-05 Clutch Switch [F]</p>	<p>P-06 Combination Switch [F]</p>	

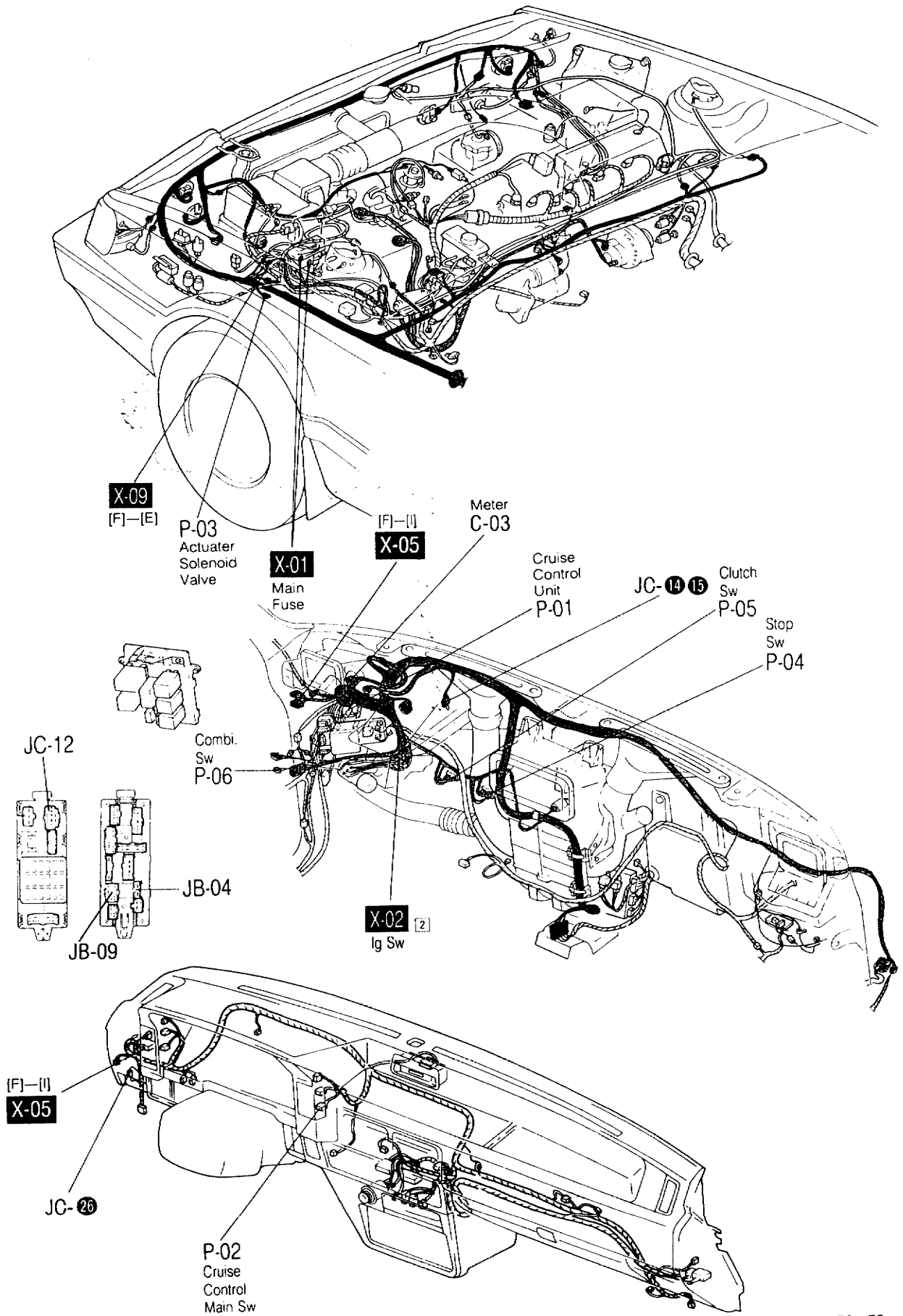

**Q**

**■ CENTER DIFFERENTIAL SYSTEM**

Note:  
× ...Not Used

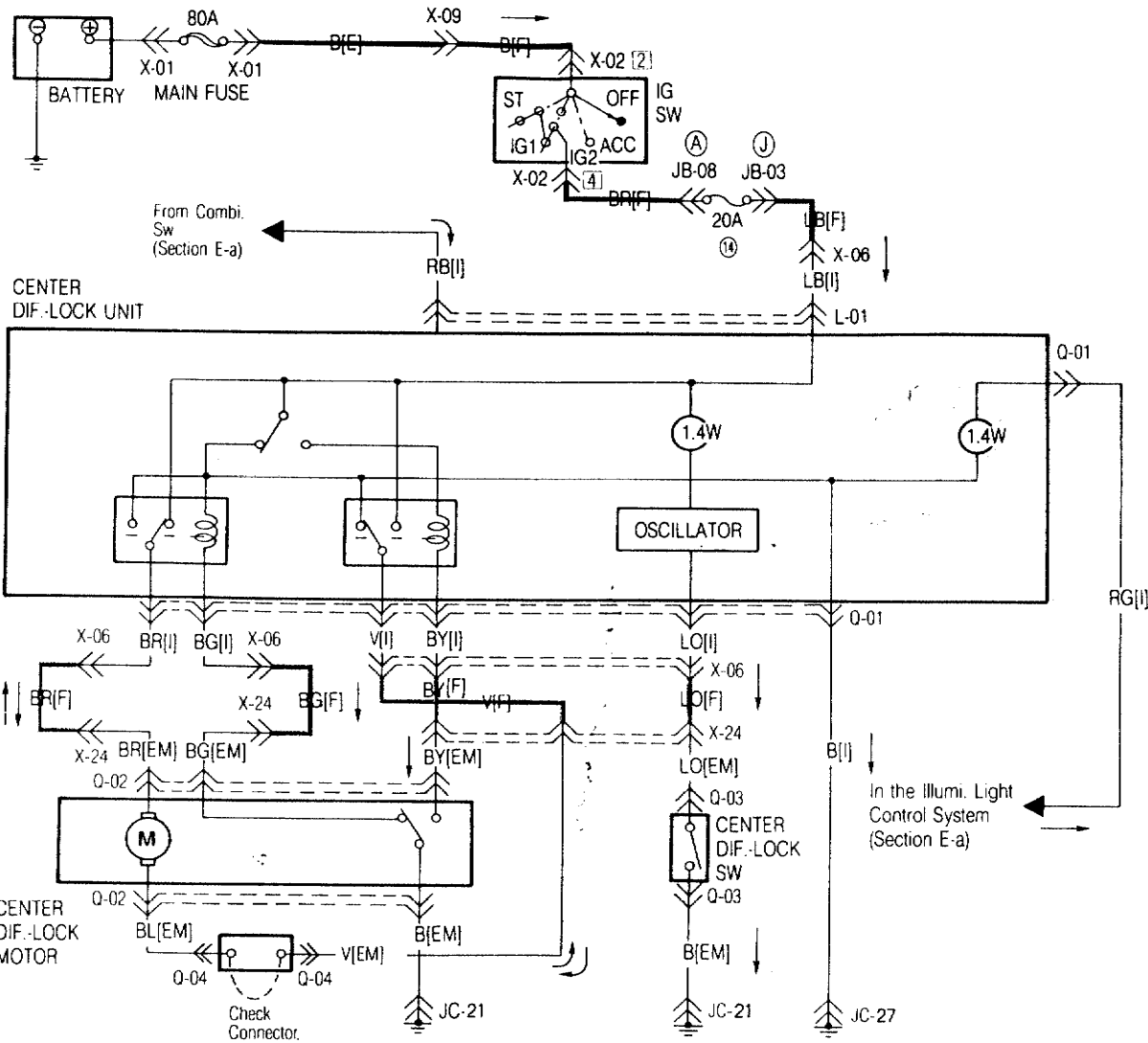

Q-01 Center Dif.-lock Unit [I]

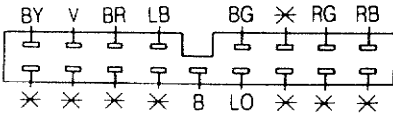

Q-02 Dif.-lock Motor [EM]

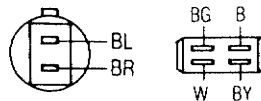

Q-03 Center Dif.-lock Sw [EM]



Q-04 Check Connector [EM]







COMMON CONNECTOR LIST

Note: \* No Used

<p>X-01 MAIN FUSE [E] ( ) ... Turbo without 4WD</p>	<p>X-02 Ignition Switch [F] ( ) ... 4AT</p>	<p>X-03 Connector Between Front [F] And Emission [EM] Harness &lt; &gt; 4AT ( ) Turbo without 4WD ( ) 4WD</p>			
<p>X-04 Connector Between Front [F] And Emission [EM] Harness &lt; &gt; 4AT ( ) Turbo without 4WD ( ) 4WD</p>	<p>X-05 Connector Between Front [F] And Instrument Panel [I] Harness ( ) ... 4WD</p>	<p>X-06 Connector Between Front [F] And Instrument Panel [I] Harness (For 4WD)</p>			
<p>X-07 Connector Between Front [F] And Rear [R] Harness ( ) ... 4AT &lt; &gt; 4WD ( ) ... 4 Door</p>	<p>X-08 Connector Between Front [F] And Engine [E] Harness ( ) ... 4WD</p>	<p>X-09 Connector Between Front [F] And Engine [E] Harness</p>			
<p>X-10 Connector Between Front [F] And Door [Dr1] Harness ( ) ... 4WD &lt; &gt; 3 Door</p>	<p>X-11 Connector Between Front [F] And Floor [Fr] Harness ( ) Turbo</p>	<p>X-12 Connector Between Front [F] And Floor [Fr] Harness</p>			
<p>X-13 Connector Between Front [F] And Interior Light [In] Harness</p>	<p>X-14 Connector Between Front [F] And No. 1 Door [Dr1] Harness</p>	<p>X-15 Connector Between Front [F] And No. 2 Door [Dr2] Harness</p>	<p>X-16 Connector Between Front [F] And No. 2 Door [Dr2] Harness</p>	<p>X-17 Connector Between Rear [R] And No. 2 Rear [R2] Harness (3 And 5 Door)</p>	<p>X-17 Connector Between Rear [R] And No. 2 Rear [R2] Harness (4 Door)</p>
<p>X-18 Connector Between Floor [Fr] And No. 1 Door [Dr1] Harness (4 And 5 Door)</p>	<p>X-19 Connector Between Floor [Fr] And No. 3 Door [Dr3] Harness (4 And 5 Door)</p>	<p>X-20 Connector Between Floor [Fr] And No. 4 Door [Dr4] Harness (4 And 5 Door)</p>	<p>X-21 Connector Between Emission [EM] And Engine [E] Harness</p>	<p>X-22 Connector Between Emission [EM] And Air Con. [AC] Harness</p>	<p>X-23 Connector Between Instrument Panel [I] And Air Con. [AC] Harness</p>
<p>X-24 Connector Between Front [F] And Emission [EM] Harness (For 4WD)</p>	<p>X-25 Joint Connector [I]</p>	<p>X-26 Joint Connector [F]</p>	<p>X-27 Connector Between Rear [R] And No. 2 Rear [R2] Harness</p>		

# WIRING DIAGRAM 50-Q

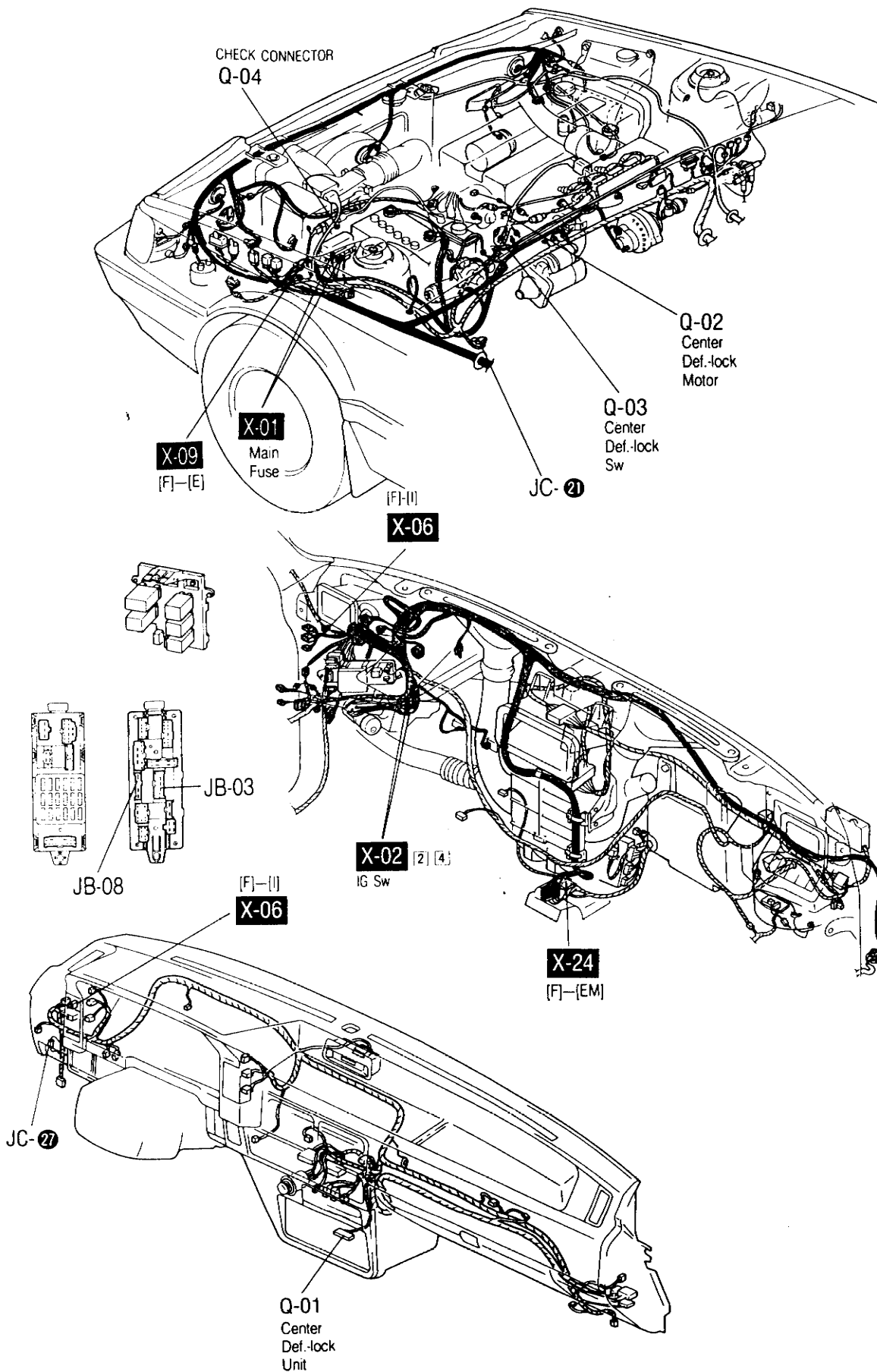

JC

GROUND CIRCUIT

Note: Wiring order into the Joint connector may be changed  
 \* ...Not Used

Front Harness

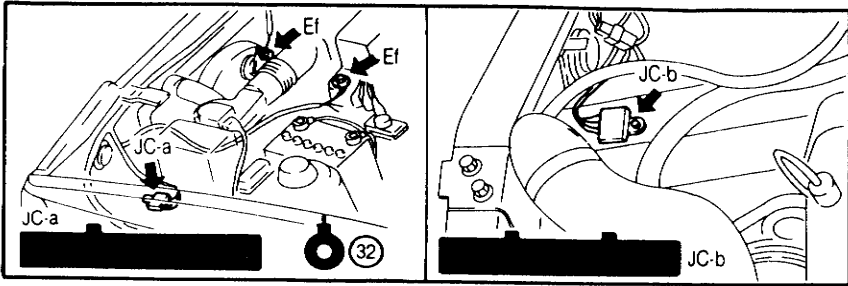

Rear Harness

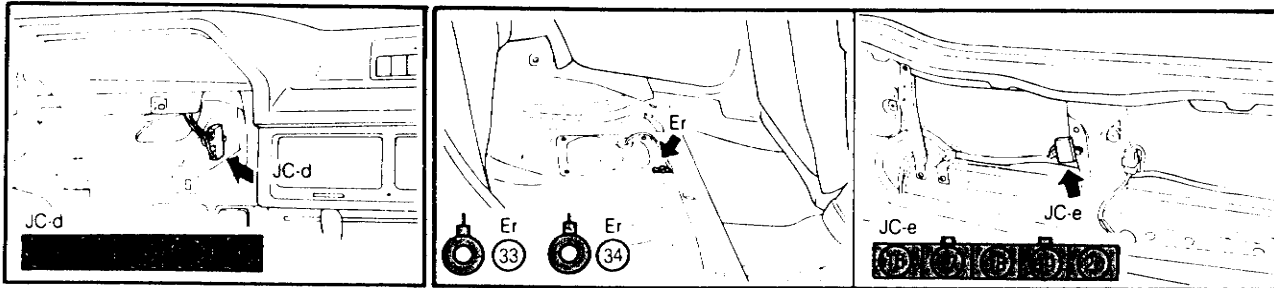

Emission Harness

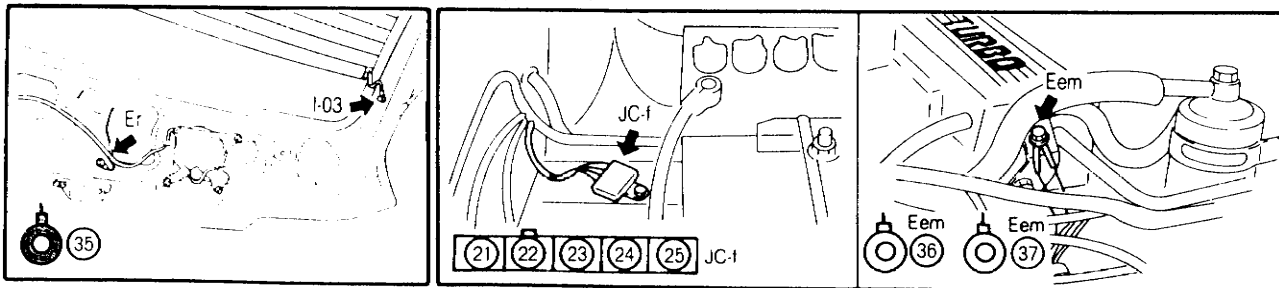

Instrument Harness

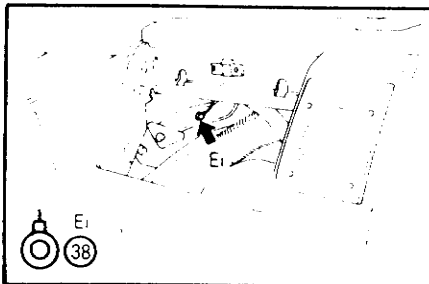

Air Con. Harness

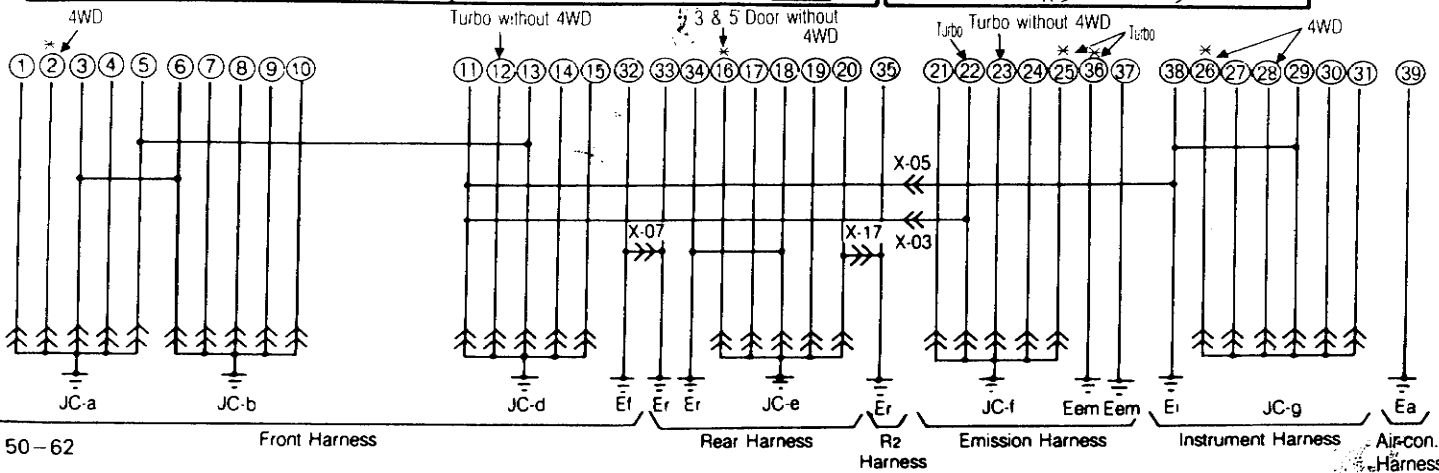
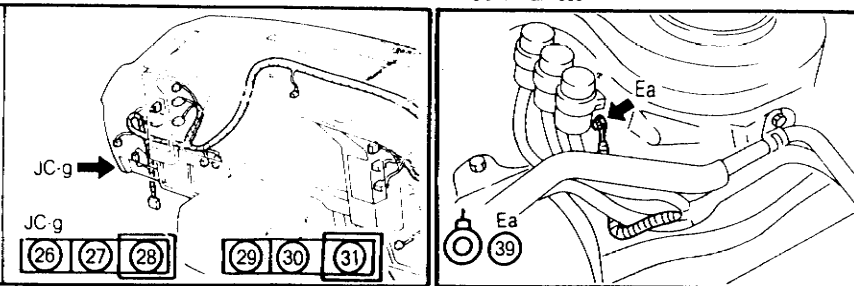

# INTER CONNECTING DIAGRAM OF JOINT BOX

Note  
 \* ...Not Used

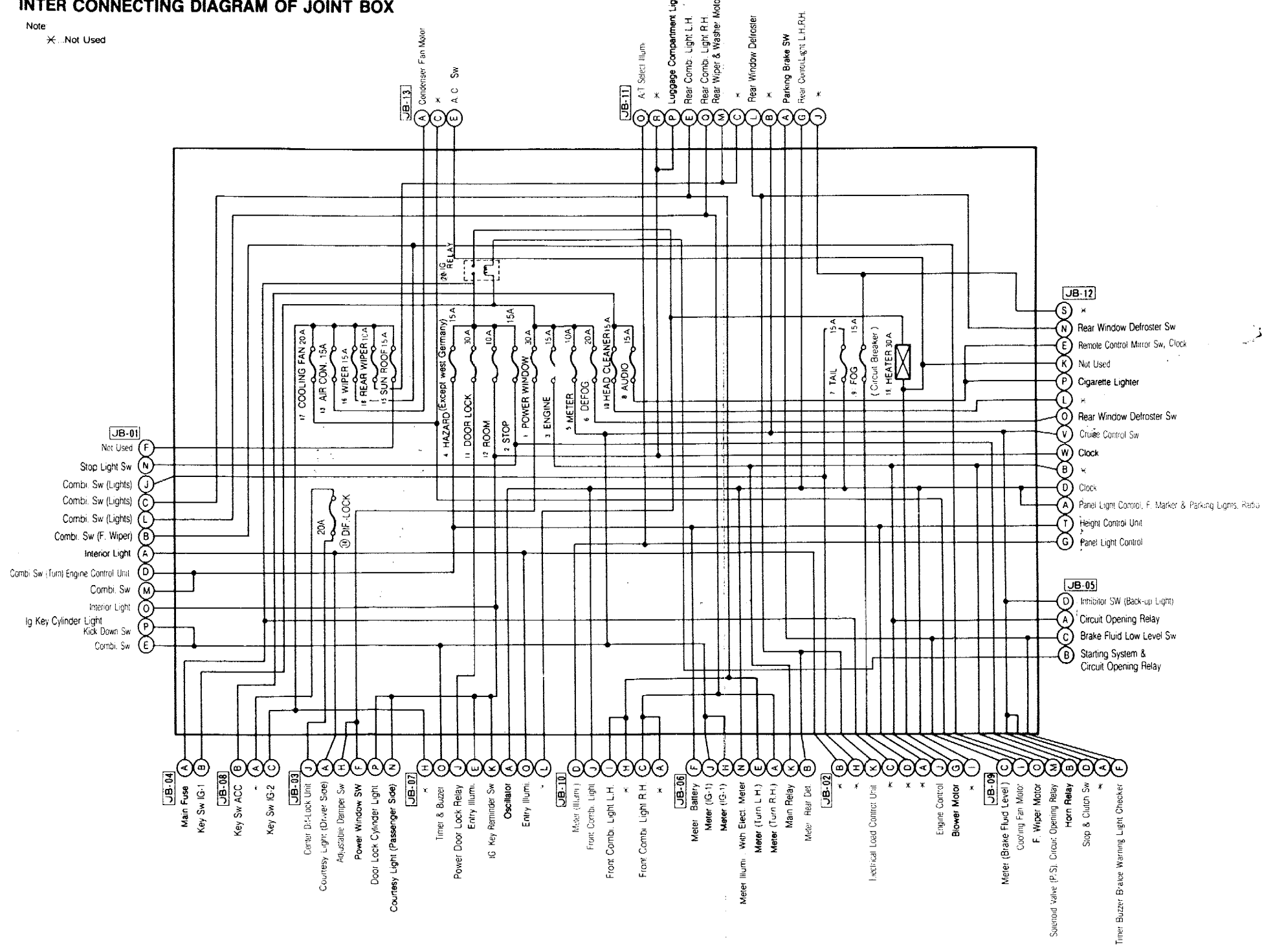

- JB-01**
- (F) Not Used
  - (N) Stop Light Sw
  - (J) Combi. Sw (Lights)
  - (C) Combi. Sw (Lights)
  - (L) Combi. Sw (Lights)
  - (B) Combi. Sw (F. Wiper)
  - (A) Interior Light
  - (D) Combi. Sw (Turn Engine Control Unit)
  - (M) Combi. Sw
  - (O) Interior Light
  - (P) Ig Key Cylinder Light
  - (E) Kick Down Sw
  - (S) Combi. Sw

- JB-04**
- (A) Main Fuse
  - (B) Key Sw IG-1
- JB-08**
- (B) Key Sw ACC
  - (C) Key Sw IG-2
- JB-09**
- (J) Center B-Lock Unit
  - (K) Courtesy Light (Driver Side)
  - (H) Adjustable Damper Sw
  - (F) Power Window SW
  - (P) Door Lock Cylinder Light
  - (N) Courtesy Light (Passenger Side)

- JB-07**
- (H) Timer & Buzzer
  - (J) Power Door Lock Relay
  - (O) Entry Illum.
  - (K) Ig Key Reminder Sw
  - (A) Oscillator
  - (L) Entry Illum.
- JB-10**
- (D) Meter (Illum.)
  - (I) Front Combi. Light
  - (L) Front Combi. Light L.H.
  - (C) Front Combi. Light R.H.
  - (A) Meter

- JB-06**
- (F) Meter Battery
  - (G-1) Meter (IG-1)
  - (H) Meter (IG-1)
  - (N) Meter Illum. With Elect. Meter
  - (E) Meter (Turn L.H.)
  - (A) Meter (Turn R.H.)
  - (K) Main Relay
  - (B) Meter Rear Det.
- JB-02**
- (B) Electrical Load Control Unit
  - (H) \*
  - (K) \*
  - (C) \*
  - (D) \*
  - (A) \*
  - (V) \*
  - (I) \*

- JB-09**
- (C) Meter (Brake Fluid Level)
  - (F) Cooling Fan Motor
  - (N) F. Wiper Motor
  - (B) Horn Relay
  - (D) Stop & Clutch Sw
  - (K) Timer Buzzer
  - (A) Brake Warning Light Checker

- JB-11**
- (O) A.T. Select Illum.
  - (R) \*
  - (P) Luggage Compartment Light
  - (E) Rear Comb. Light L.H.
  - (O) Rear Comb. Light R.H.
  - (M) Rear Wiper & Washer Motor
  - (C) \*
  - (L) Rear Window Defroster
  - (B) \*
  - (A) Parking Brake Sw
  - (G) Rear Combi. Light L.H./R.H.
  - (J) \*

- JB-12**
- (S) \*
  - (N) Rear Window Defroster Sw
  - (E) Remote Control Mirror Sw, Clock
  - (P) Cigarette Lighter
  - (L) \*
  - (O) Rear Window Defroster Sw
  - (V) Cruise Control Sw
  - (W) Clock
  - (B) \*
  - (D) Clock
  - (A) Panel Light Control, F. Marker & Parking Lights, Radio
  - (T) Height Control Unit
  - (G) Panel Light Control

- JB-05**
- (D) Inhibitor SW (Back-up Light)
  - (A) Circuit Opening Relay
  - (C) Brake Fluid Low Level Sw
  - (B) Starting System & Circuit Opening Relay

- JB-13**
- (A) Condenser Fan Motor
  - (E) \*
  - (C) A.C. Sw

- JB-05**
- (D) Inhibitor SW (Back-up Light)
  - (A) Circuit Opening Relay
  - (C) Brake Fluid Low Level Sw
  - (B) Starting System & Circuit Opening Relay

- JB-12**
- (S) \*
  - (N) Rear Window Defroster Sw
  - (E) Remote Control Mirror Sw, Clock
  - (P) Cigarette Lighter
  - (L) \*
  - (O) Rear Window Defroster Sw
  - (V) Cruise Control Sw
  - (W) Clock
  - (B) \*
  - (D) Clock
  - (A) Panel Light Control, F. Marker & Parking Lights, Radio
  - (T) Height Control Unit
  - (G) Panel Light Control

- JB-05**
- (D) Inhibitor SW (Back-up Light)
  - (A) Circuit Opening Relay
  - (C) Brake Fluid Low Level Sw
  - (B) Starting System & Circuit Opening Relay

- JB-09**
- (C) Meter (Brake Fluid Level)
  - (F) Cooling Fan Motor
  - (N) F. Wiper Motor
  - (B) Horn Relay
  - (D) Stop & Clutch Sw
  - (K) Timer Buzzer
  - (A) Brake Warning Light Checker

Solenoid Valve (P.S.) Circuit Opening Relay

# JB CONNECTOR LOCATION

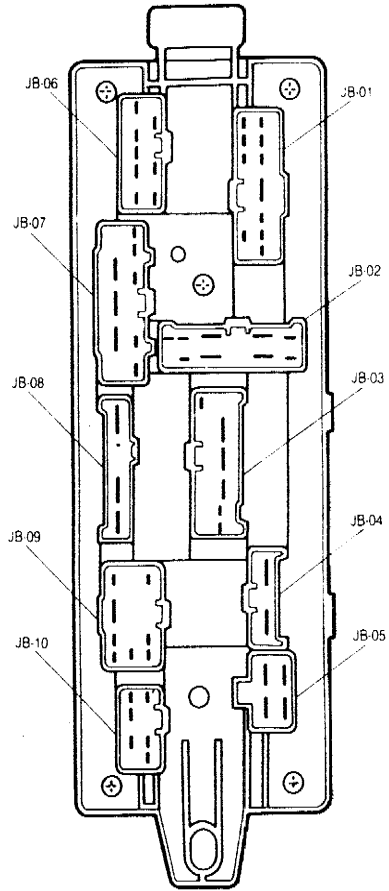
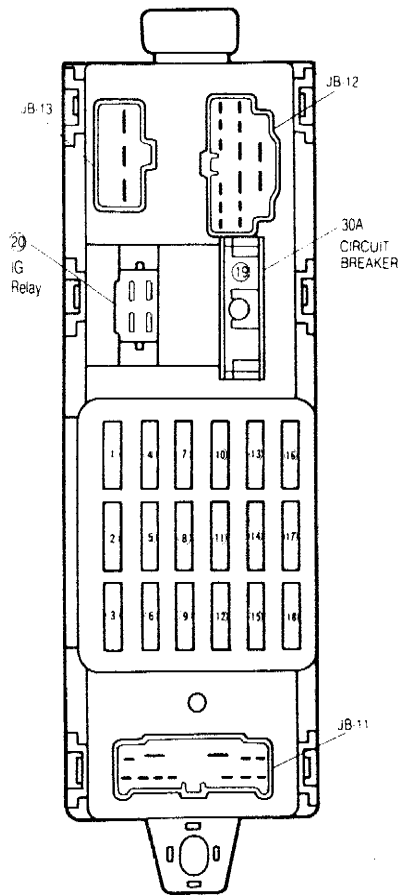

NO	CIRCUIT NAME	FUSE
①	POWER WINDOW	30A
②	STOP or HORN	15A
③	ENGINE	15A
④	HAZARD	15A
⑤	METER	10A
⑥	REAR WINDOW DEFROSTER	20A
⑦	TAIL	15A
⑧	AUDIO	15A
⑨	Not Used	

NO	CIRCUIT NAME	FUSE
⑩	Not Used	
⑪	DOOR LOCK	30A
⑫	ROOM	10A
⑬	AIR CONDITIONER	15A
⑭	CENTER DIF. LOCK	20A
⑮	SUNROOF	15A
⑯	WIPER	15A
⑰	COOLING FAN	20A
⑱	REAR WIPER	10A

## JOINT BOX

Note: Turbo with 4WD  
 Turbo without 4WD  
 Not used

# JB

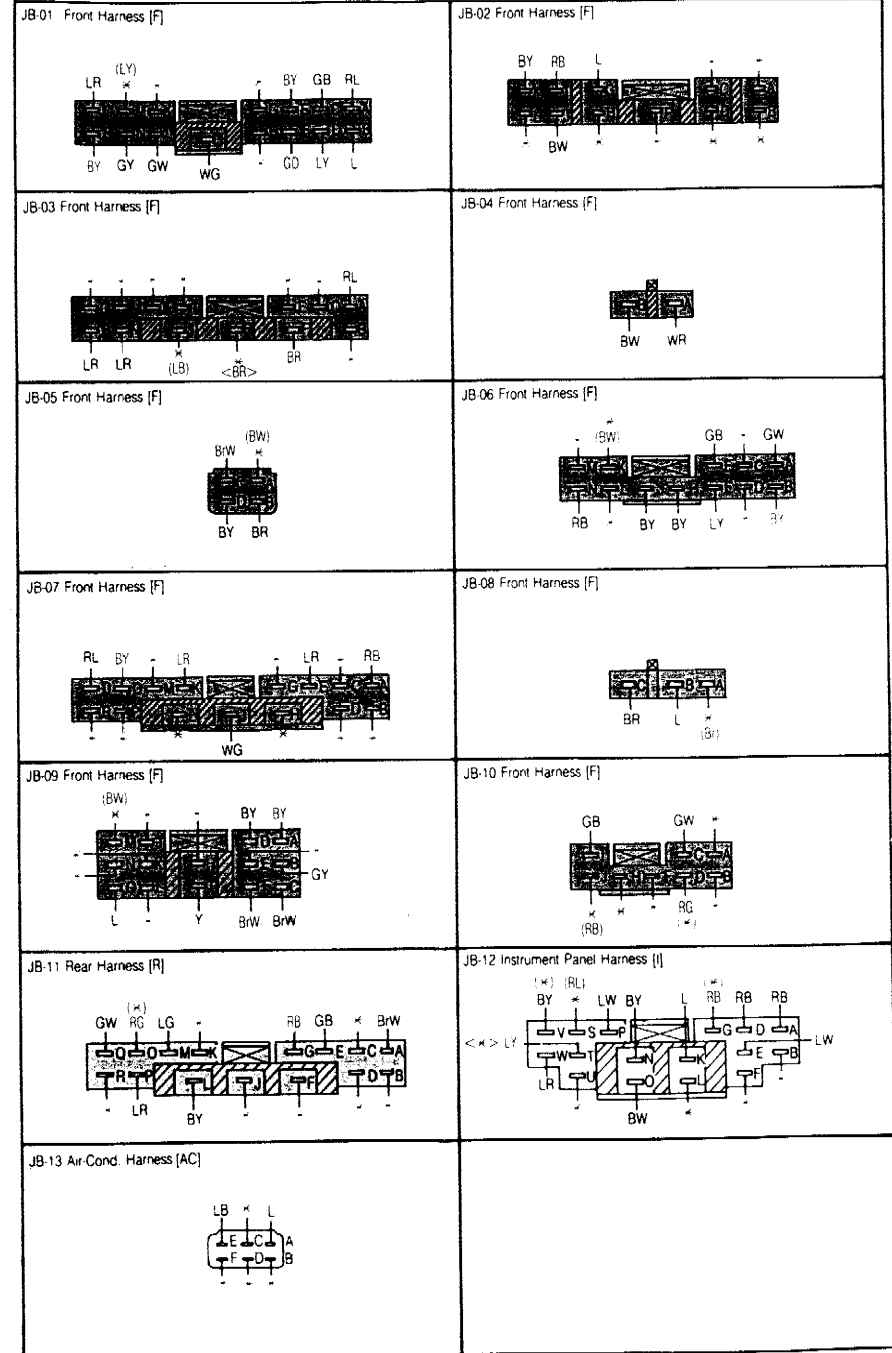

# 50 WIRING DIAGRAM LIQUID CRYSTAL DISPLAY (ELECTRONIC) METER

Note  
\* Not Used

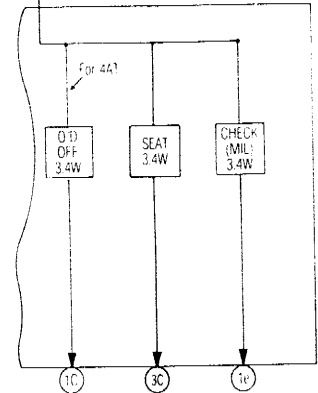
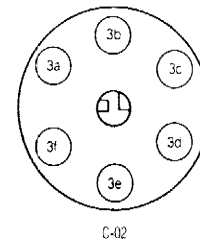
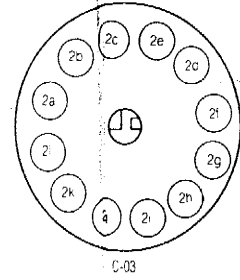
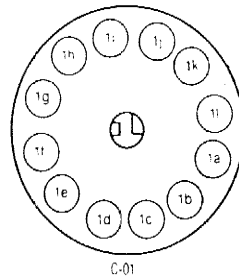
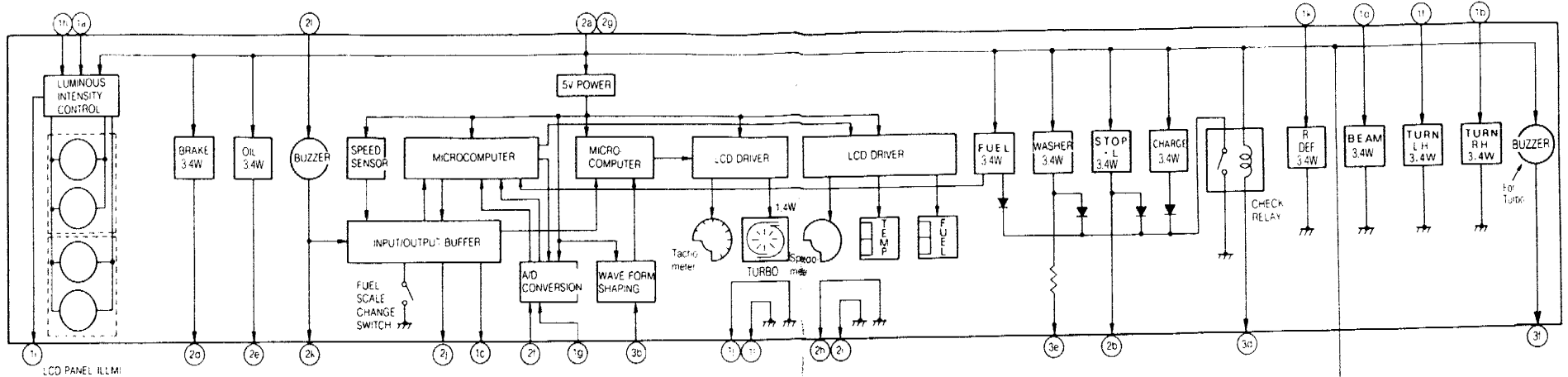

No.	Connecting to	Wiring Color
1a	Combi. Switch	RB
1b	Combi. Switch (Turn R H)	GW
1c	Engine Control Unit (For Turbo)	WL
1d	Combi. Switch (High Beam)	RW
1e	Engine Control Unit	LG
1f	Combi. Switch (Turn L H)	GB
1g	Water Temp. Sensor	YW
1h	Panel Light Control	RG
1i	Ground	B
1j	Ground	BG
1k	Rear Window Defroster Sw	BY
1l	Ground	BG

No.	Connecting to	Wiring Color
2a	Ignition Switch (IG1)	BY
2b	Stop Light Checker	BrB
2c	---	WR
2d	Brake Fluid Level Switch	BrW
2e	Oil Pressure Switch	YR
2f	Fuel Tank Unit	Y
2g	Ignition Switch (IG1)	BY
2h	Ground	B
2i	Ground	B
2j	Height Control Unit (For 4WD)	GR
2k	Oscillator	Br
2l	Battery (+ ♂)	LY

No.	Connecting to	Wiring Color
3a	IG Sw (IG)	BY
3b	Ignition Coil (-)	YL
3c	Turner & Buzzer (Seat Belt)	GU
3d	Alternator	WB
3e	Washer Level Sensor	G
3f	Pressure Switch (For Turbo)	LG

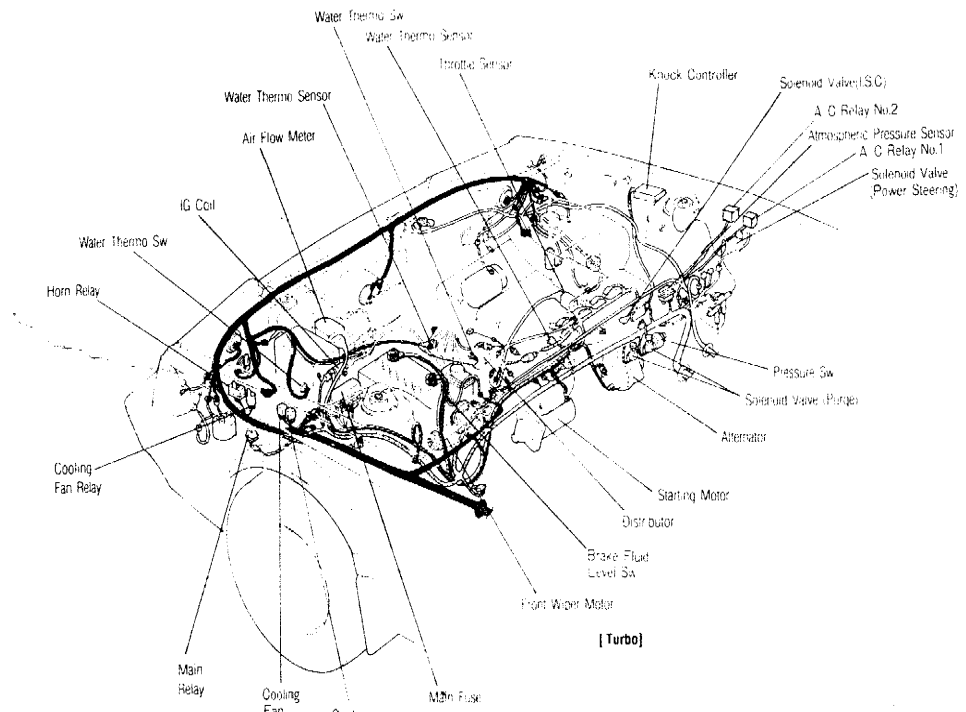

[ Turbo ]

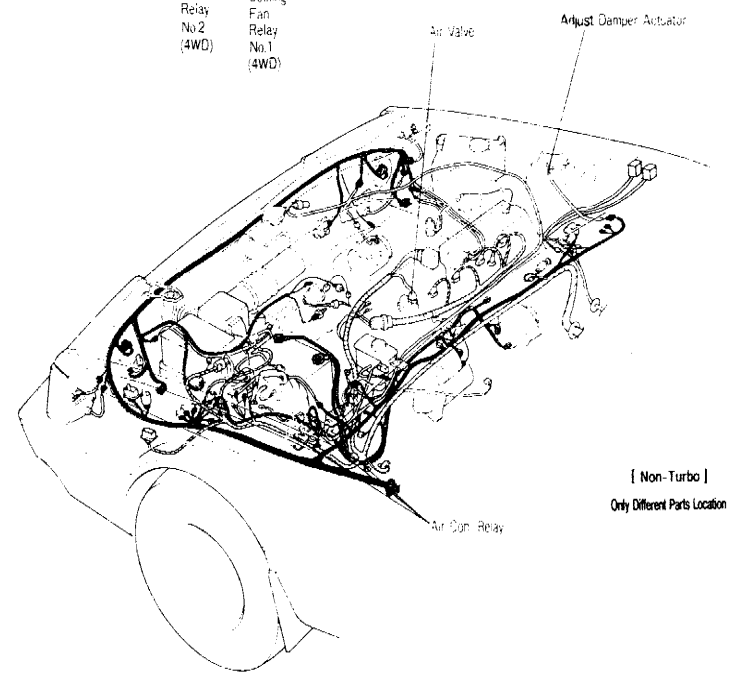

[ Non-Turbo ]  
Only Different Parts Location

