

MANUAL TRANSAXLE (F5M-R)

INDEX	J1- 2
OUTLINE	J1- 3
SPECIFICATIONS.....	J1- 3
STRUCTURAL VIEW.....	J1- 4
POWER FLOW	J1- 5
TROUBLESHOOTING GUIDE	J1- 6
TRANSAXLE OIL	J1- 7
INSPECTION	J1- 7
REPLACEMENT.....	J1- 7
TRANSAXLE	J1- 8
PREPARATION	J1- 8
REMOVAL	J1-10
DISASSEMBLY	J1-14
INSPECTION	J1-27
ASSEMBLY	J1-30
INSTALLATION.....	J1-48
DIFFERENTIAL	J1-52
PREPARATION	J1-52
DISASSEMBLY / INSPECTION / ASSEMBLY	J1-53
SHIFT MECHANISM	J1-56
OVERHAUL	J1-56

03U0J1-001

INDEX

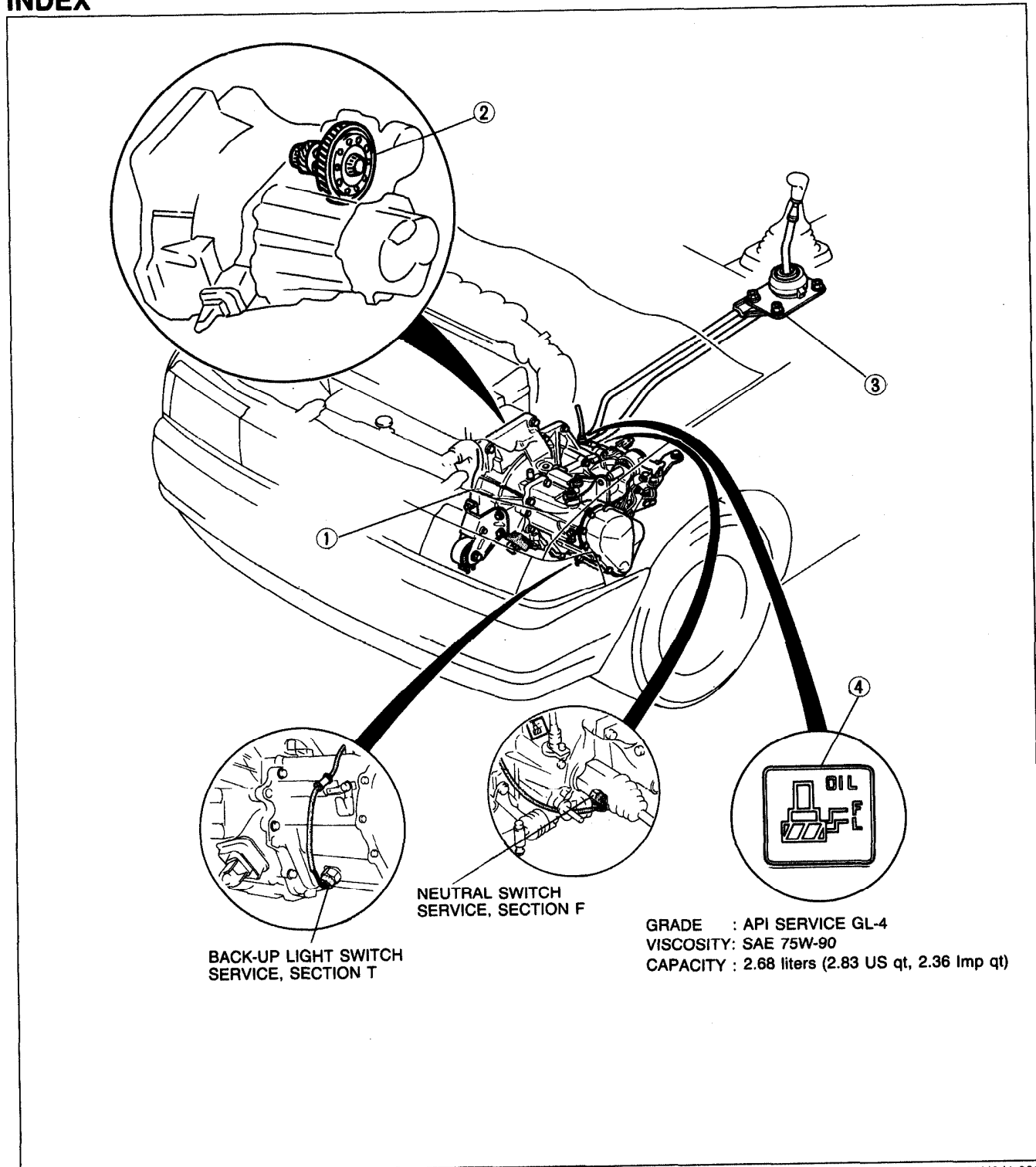

03U0J1-002

1. Transaxle		2. Differential	
Removal.....	page J1-10	Disassembly / Inspection /	
Disassembly.....	page J1-14	Assembly.....	page J1-53
Inspection.....	page J1-27	3. Shift mechanism	
Assembly.....	page J1-30	Overhaul.....	page J1-56
Installation.....	page J1-48	4. Transaxle oil	
		Inspection.....	page J1- 7
		Replacement.....	page J1- 7

OUTLINE

SPECIFICATIONS

Engine/Transaxle		B6 SOHC	BP SOHC
		F5M-R	
Item			
Transaxle control		Floor shift	
Synchromesh system		Forward: Synchromesh Reverse: Selective sliding	
Gear ratio	1st	3.416	
	2nd	1.842	
	3rd	1.290	
	4th	0.918	
	5th	0.731	
	Reverse	3.214	
Final gear ratio		4.105	3.619
Oil	Grade	API service GL-4	
	Viscosity	SAE 75W-90	
	Capacity liters (US qt, Imp qt)	2.68 (2.83, 2.36)	

J1

13U0J1-001

STRUCTURAL VIEW

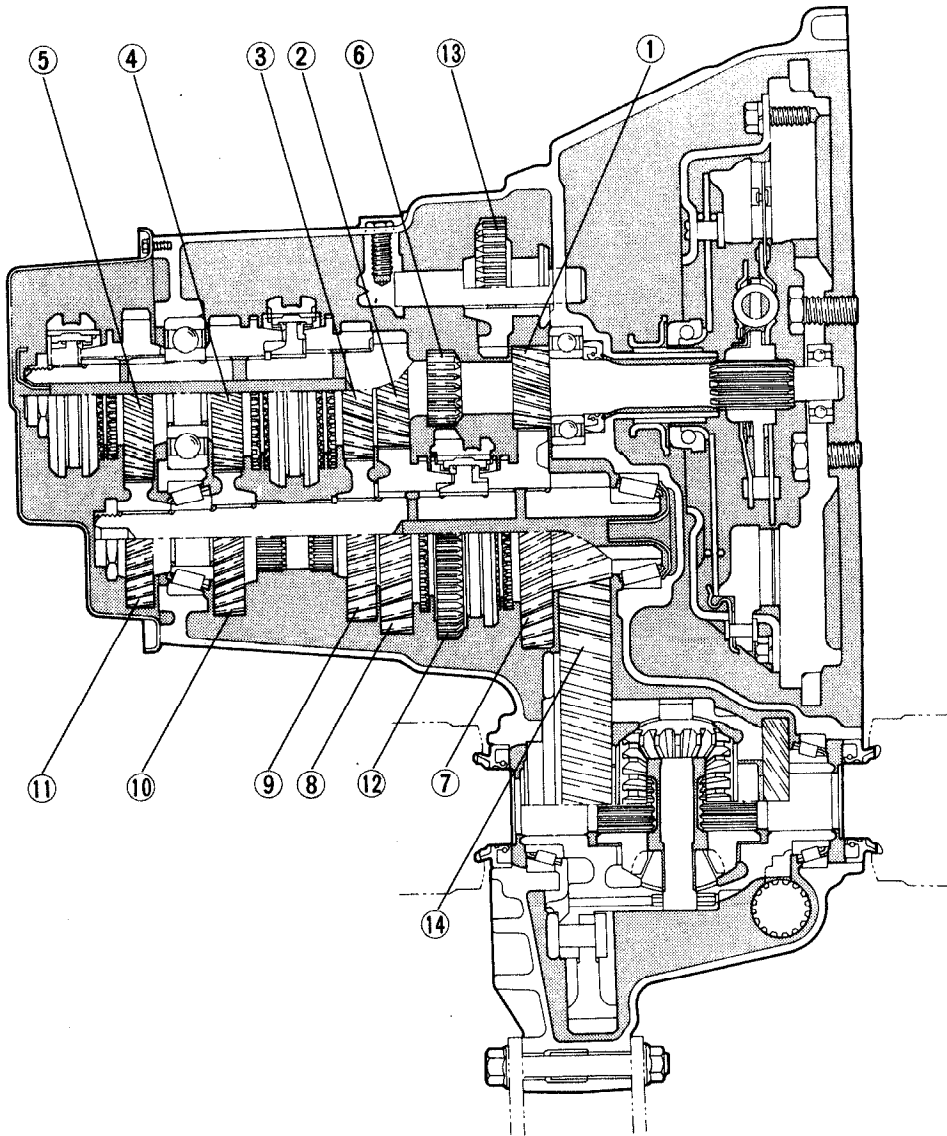

03U0J1-004

- 1. Primary 1st gear
- 2. Primary 2nd gear
- 3. Primary 3rd gear
- 4. Primary 4th gear
- 5. Primary 5th gear

- 6. Primary reverse gear
- 7. Secondary 1st gear
- 8. Secondary 2nd gear
- 9. Secondary 3rd gear
- 10. Secondary 4th gear

- 11. Secondary 5th gear
- 12. Secondary reverse gear
- 13. Reverse idler gear
- 14. Differential

POWER FLOW

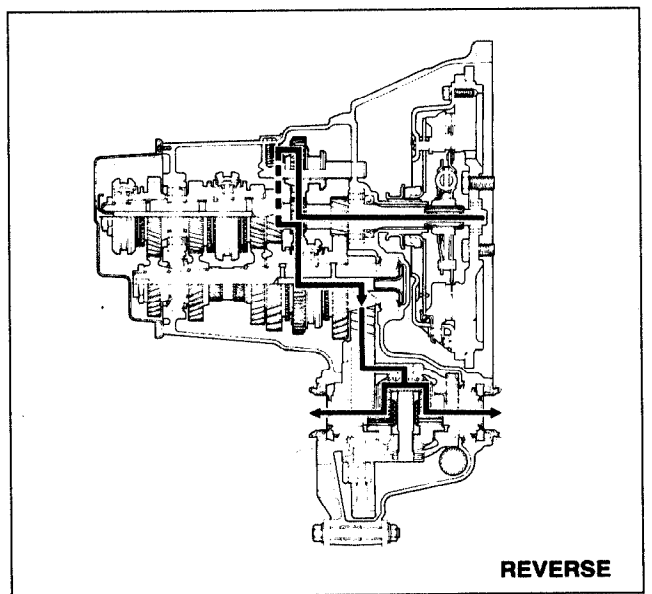
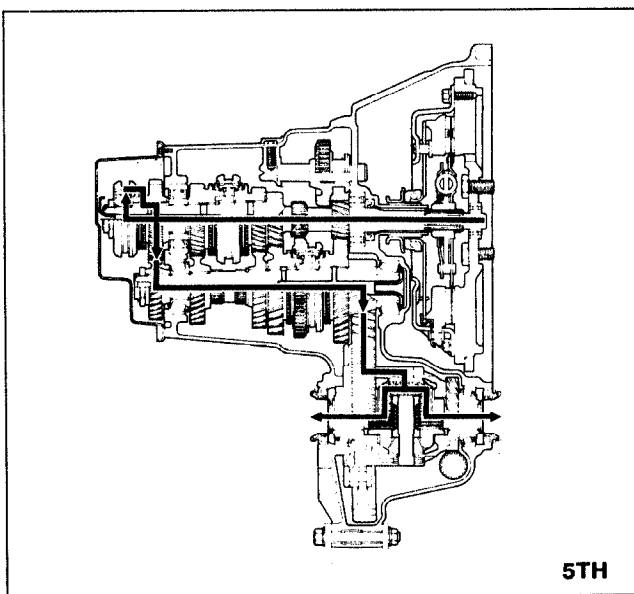
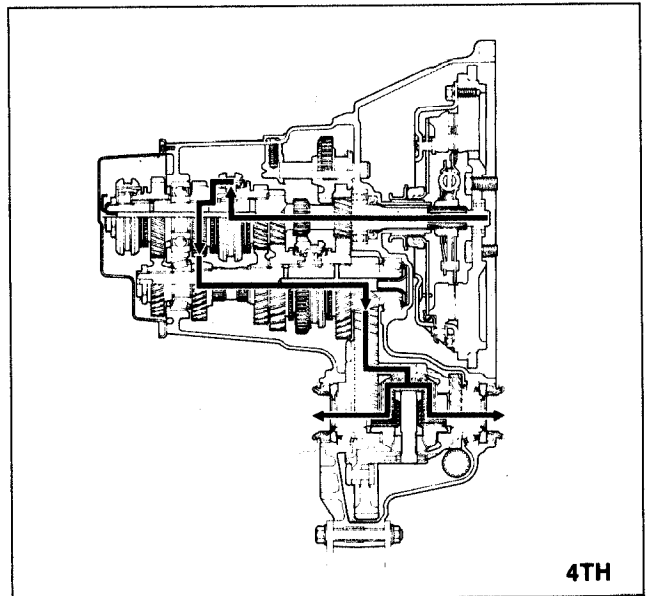
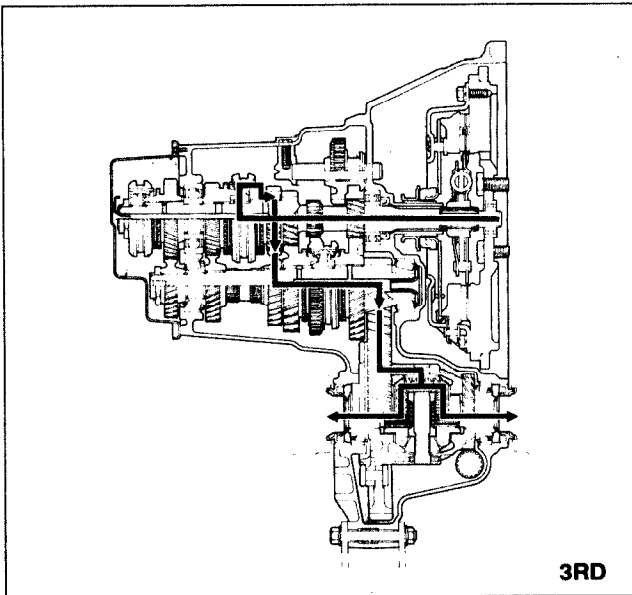
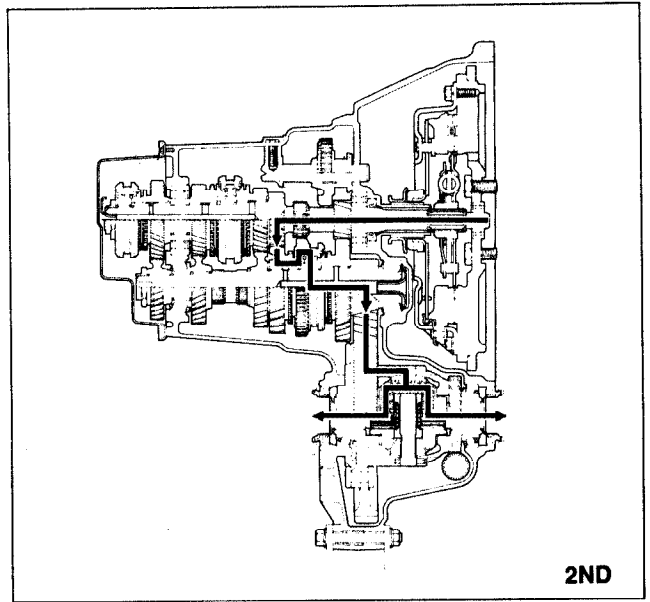
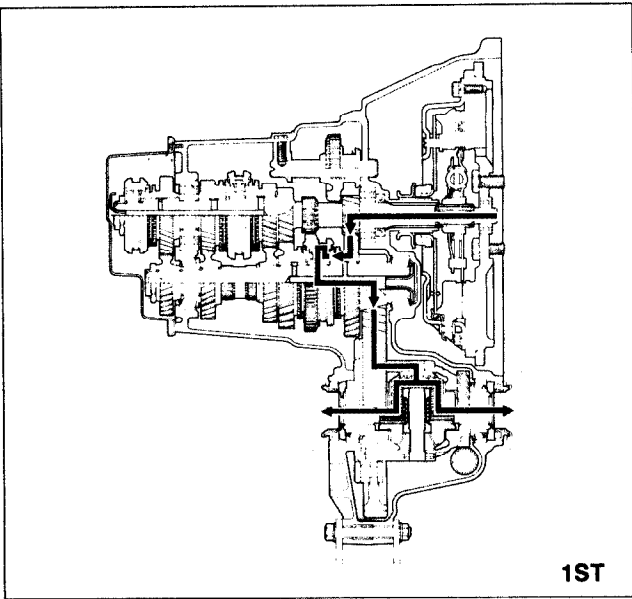

J1

TROUBLESHOOTING GUIDE

Problem	Possible cause	Remedy	Page
Shift lever won't shift smoothly or is hard to shift	Seized shift lever ball	Replace	J1-56
	Seized change control rod joint	Replace	J1-56
	Bent change control rod	Replace	J1-56
Too much play in shift lever	Worn change control rod bushing	Replace	J1-56
	Weak shift lever ball spring	Replace	J1-56
	Worn shift lever ball bushing	Replace	J1-56
Difficult to shift	Bent change rod	Replace	J1-56
	No grease in transaxle control	Lubricate with grease	J1-56
	Insufficient oil	Add oil	J1- 7
	Deterioration of oil quality	Replace with oil of specified quality	J1- 7
	Wear or play of shift fork or shift rod	Replace	J1-14
	Worn synchronizer ring	Replace	J1-22, 24
	Worn synchronizer cone of gear	Replace	J1-22, 24
	Bad contact of synchronizer ring and cone of gear	Replace	J1-22, 24
	Excessive longitudinal play of gears	Replace	J1-22, 24
	Worn bearing	Replace	J1-22, 24
	Worn synchronizer key spring	Replace	J1-22, 24
	Excessive primary shaft gear bearing preload	Adjust	J1-36
	Improperly adjusted change guide plate	Adjust	J1-17
Won't stay in gear	Bent change control rod	Replace	J1-56
	Worn change control rod bushing	Replace	J1-56
	Weak shift lever ball spring	Replace	J1-56
	Improperly installed extension bar	Tighten	J1-56
	Worn shift fork	Replace	J1-14
	Worn clutch hub	Replace	J1-22, 24
	Worn clutch hub sleeve	Replace	J1-22, 24
	Worn gear sliding part of both shaft gears	Replace	J1-22, 24
	Worn gear sliding part of each gear	Replace	J1-22, 24
	Worn steel sliding groove of control end	Replace	J1-14
	Weak spring pressing against steel ball	Replace	J1-14
	Excessive thrust clearance	Replace	J1-22, 24
	Worn bearing	Replace	J1-22, 24
Improperly installed engine mount	Tighten	J1-48	
Abnormal noise	Insufficient oil	Add oil	J1- 7
	Deterioration of oil quality	Replace	J1- 7
	Worn bearing	Adjust or replace	J1-22, 24
	Worn sliding surfaces of gears or shafts	Replace	J1-22, 24
	Excessive gear backlash	Replace	J1-22, 24
	Damaged gear teeth	Replace with oil of specified quality	J1-22, 24
	Foreign material in gears	Replace	J1-22, 24
Damaged differential gear or excessive backlash	Adjust or replace	J1-53	

03U0J1-006

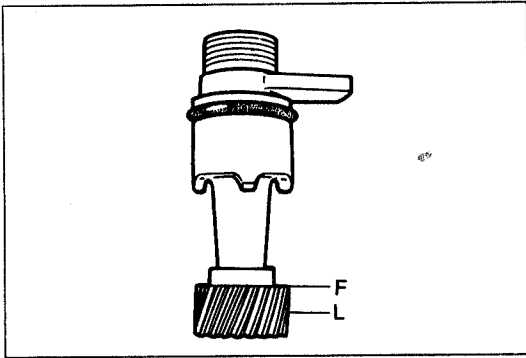

03U0J1-007

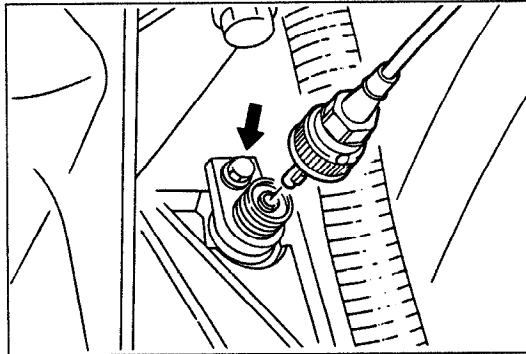

03U0J1-008

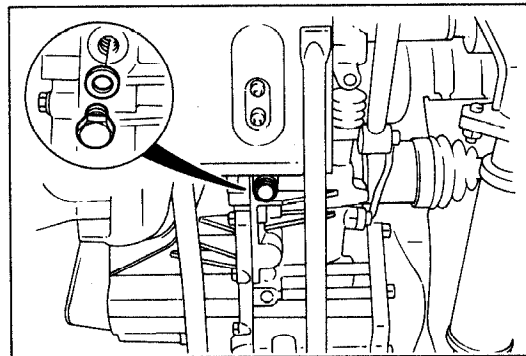

03U0J1-009

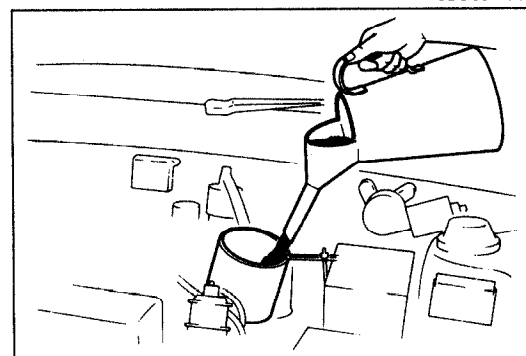

13U0J1-002

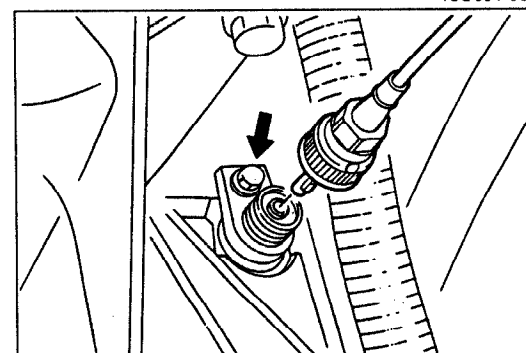

03U0J2-011

TRANSAXLE OIL

INSPECTION

Note

- Park the vehicle on level ground.

1. Disconnect the speedometer cable and remove the speedometer driven gear.
2. Verify that the oil level is between the F and L.
3. Install the speedometer driven gear.

Tightening torque:

7.8—12 N·m (80—120 cm·kg, 69—104 in·lb)

4. Connect the speedometer cable.

J1

REPLACEMENT

1. Disconnect the speedometer cable and remove the speedometer driven gear.
2. Remove the drain plug and washer. Drain the oil into a suitable container.
3. Install a new washer and the drain plug.

Tightening torque:

39—54 N·m (4.0—5.5 m·kg, 29—40 ft·lb)

4. Add the necessary amount of the specified oil through the speedometer driven gear mounting.

Specified oil

Grade: API service GL-4



Viscosity: SAE 75W-90

Capacity: 2.68 liters (2.83 US qt, 2.36 Imp qt)

5. Verify the oil level.
6. Install the speedometer driven gear and connect the speedometer cable.



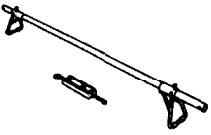
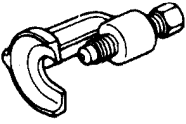
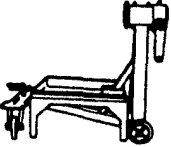
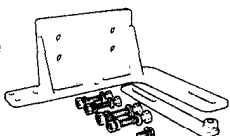
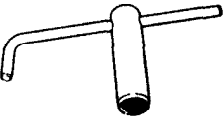
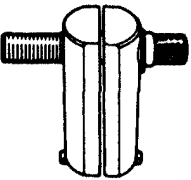
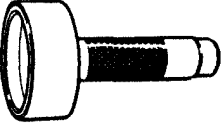
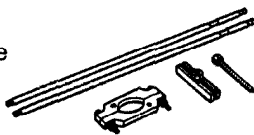
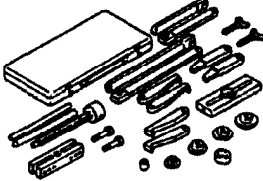
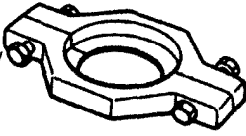
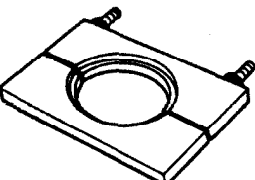
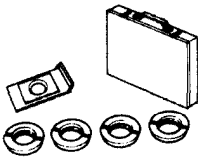
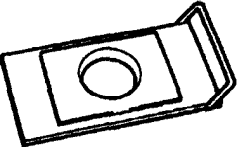
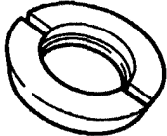
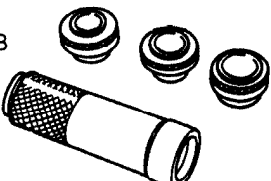



TRANSAXLE

PREPARATION SST

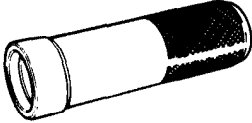
<p>49 G017 5A0 Support, engine</p> 	<p>For support of engine</p>	<p>49 0118 850C Puller, ball joint</p> 	<p>For removal of tie-rod end</p>
<p>49 0107 680A Engine stand</p> 	<p>For disassembly and assembly of transaxle</p>	<p>49 G019 0A0 Hanger, transaxle</p> 	<p>For disassembly and assembly of transaxle</p>
<p>49 F401 440 Holder, primary shaft</p> 	<p>For holding primary shaft</p>	<p>49 FT01 361 Remover, bearing</p> 	<p>For removal of bearing outer race</p>
<p>49 B001 795 Installer, oil seal</p> 	<p>For installation of oil seal</p>	<p>49 0187 520 Puller, rear axle shaft bearing</p> 	<p>For removal of bearing and gears</p>
<p>49 0839 425C Puller set, bearing</p> 	<p>For removal of bearing</p>	<p>49 0636 145 Puller, fan pulley boss</p> 	<p>For removal of gears</p>
<p>49 G030 370 Removing plate</p> 	<p>For removal of gears</p>	<p>49 G017 1A0 Remover set, bearing</p> 	<p>For removal of bearing</p>
<p>49 F401 366A Plate (Part of 49 G017 1A0)</p> 	<p>For removal of bearing</p>	<p>49 B092 374 Attachment H (Part of 49 G017 1A0)</p> 	<p>For removal of bearing</p>
<p>49 F401 330B Installer set, bearing</p> 	<p>For installation of bearing</p>	<p>49 F401 335A Attachment A (Part of 49 F401 330B)</p> 	<p>For installation of bearing inner race and gear</p>

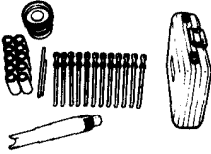
TRANSAXLE

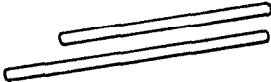
J1

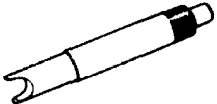
<p>49 F401 331 Body (Part of 49 F401 330B)</p> 	<p>For installation of gear and bearing inner race</p>	<p>49 F401 337A Attachment C (Part of 49 F401 330B)</p> 	<p>For installation of gear</p>
<p>49 F401 336B Attachment B (Part of 49 F401 330B)</p> 	<p>For installation of bearing</p>	<p>49 D017 2A2A Shim selector set</p> 	<p>For adjustment of bearing preload</p>
<p>49 F401 381B Selector (Part of 49 D017 2A2A)</p> 	<p>For adjustment of bearing preload</p>	<p>49 F401 384 Collar (Part of 49 D017 2A2A)</p> 	<p>For adjustment of bearing preload</p>
<p>49 F401 385 Bar (Part of 49 D017 2A2A)</p> 	<p>For adjustment of bearing preload</p>	<p>49 G019 019 Bolt set (Part of 49 D017 2A2A)</p> 	<p>For adjustment of bearing preload</p>
<p>49 FT01 515A Adapter, preload</p> 	<p>For adjustment of bearing preload</p>	<p>23U0J1-001</p>	

J1

REMOVAL

1. Disconnect the negative battery cable.
2. Raise the vehicle and support it with safety stands.
3. Drain the transaxle oil into a suitable container.
4. Remove in the order shown in the figure, referring to **Removal Note**.

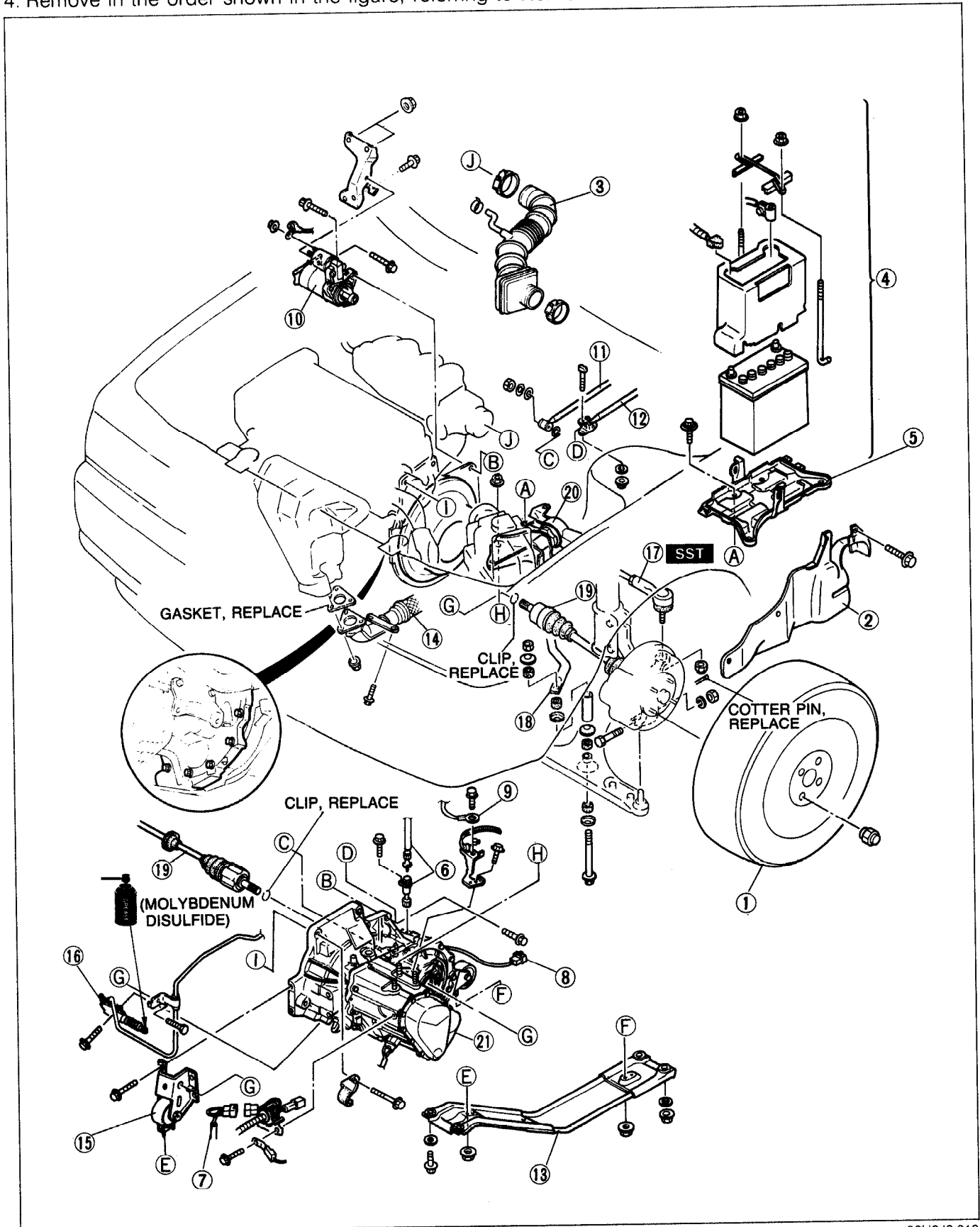

- | | |
|---|---|
| <ol style="list-style-type: none"> 1. Wheel and tire 2. Splash shield 3. Air hose and resonance chamber 4. Battery 5. Battery carrier 6. Speedometer cable 7. Back-up light switch connector 8. Neutral switch connector 9. Ground 10. Starter 11. Extension bar 12. Control rod 13. Engine mount member
Removal Note page J1-11 | <ol style="list-style-type: none"> 14. Exhaust pipe 15. Engine mount No.2 16. Clutch release cylinder
Removal Note page J1-11 17. Tie-rod end
Removal Note page J1-12 18. Stabilizer (BP SOHC) 19. Driveshaft
Removal Note page J1-12 20. Engine mount No.4 21. Transaxle
Removal Note page J1-12 |
|---|---|

03U0J1-012

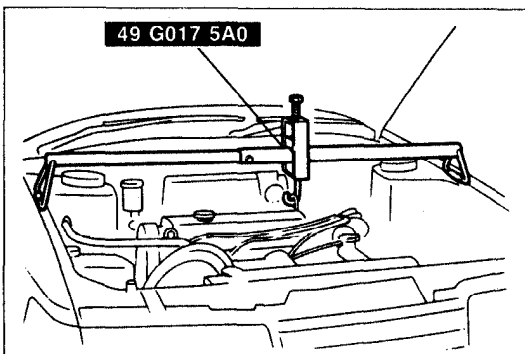

03U0J2-015

Removal Note
Engine mount member

1. Suspend the engine with the **SST** and remove the engine mount member.

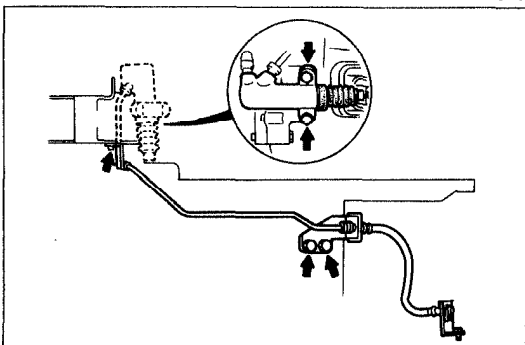

03U0J1-013

Clutch release cylinder

Caution

- Do not damage the clutch pipe.

1. Remove the bolts shown.
2. Lay aside the clutch release cylinder and the clutch pipe when removing the transaxle.

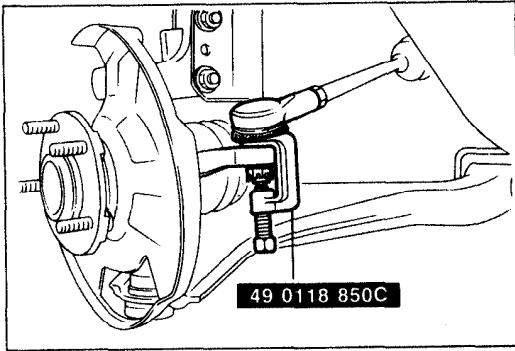

03U0J1-014

Tie-rod end

Caution

- Do not damage the dust boot.

1. Remove the cotter pin and loosen the nut.
2. Disconnect the tie-rod end with the **SST**.

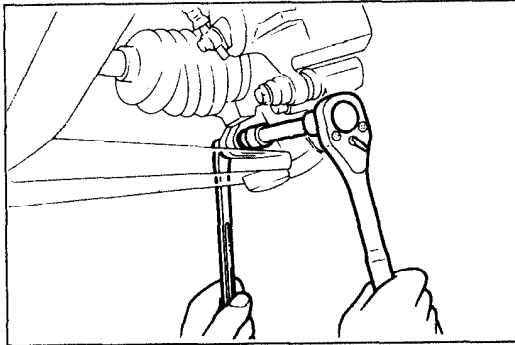

03U0J1-015

Driveshaft

1. Remove the clinch bolt.

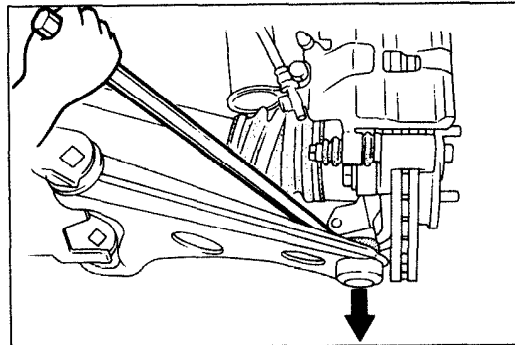

03U0J1-016

Caution

- Wrap a rag around the ball joint dust boot to protect it from damage.

2. Disconnect the lower arm from the knuckle with a pry bar.

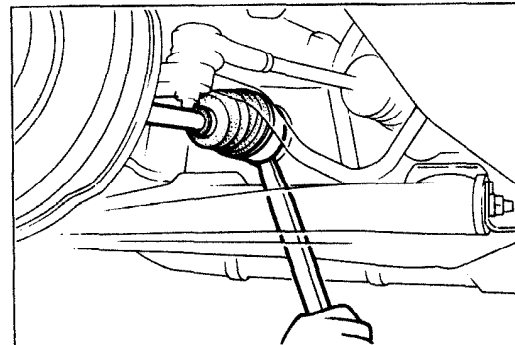

23U0J1-002

Caution

- Do not subject the tripod joint to shock when removing the driveshaft.

3. Separate the driveshaft from the transaxle by prying with a bar inserted between the outer ring and the transaxle.
4. Suspend the driveshaft with a rope.

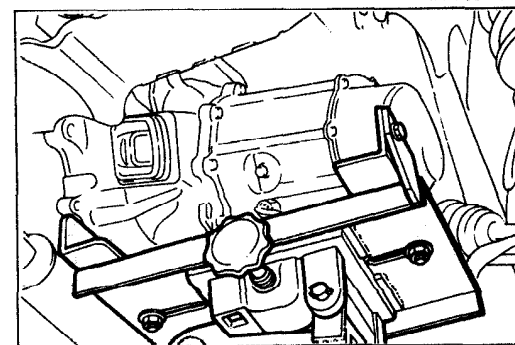

03U0J1-018

Transaxle

1. Loosen the **SST** (engine support) and lean the engine toward the transaxle.
2. Support the transaxle with a jack.

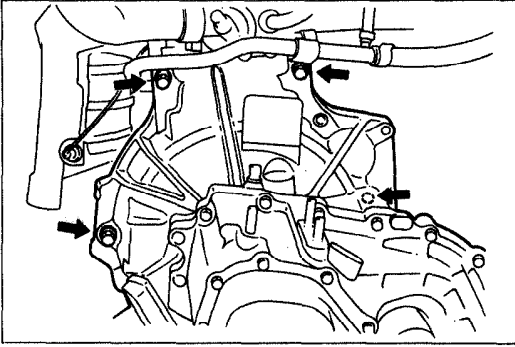

03U0J1-019

3. Remove the transaxle mounting bolts.
4. Remove the transaxle.

DISASSEMBLY

Precaution

1. Clean the transaxle exterior thoroughly with a steam cleaner or cleaning solvent before disassembly.
2. Clean the removed parts (except sealed bearings) and all sealing surfaces with cleaning solvent, and dry with compressed air. Clean out all holes and passages with a compressed air, and check that there are no obstructions.
3. Wear eye protection when using compressed air to clean components.

03U0J2-020

5th/Reverse Gear and Housing Parts

1. Measure the thrust clearance between 5th gear and the transaxle case, referring to **Preinspection**.
2. Disassemble in the order shown in the figure, referring to **Disassembly Note**.

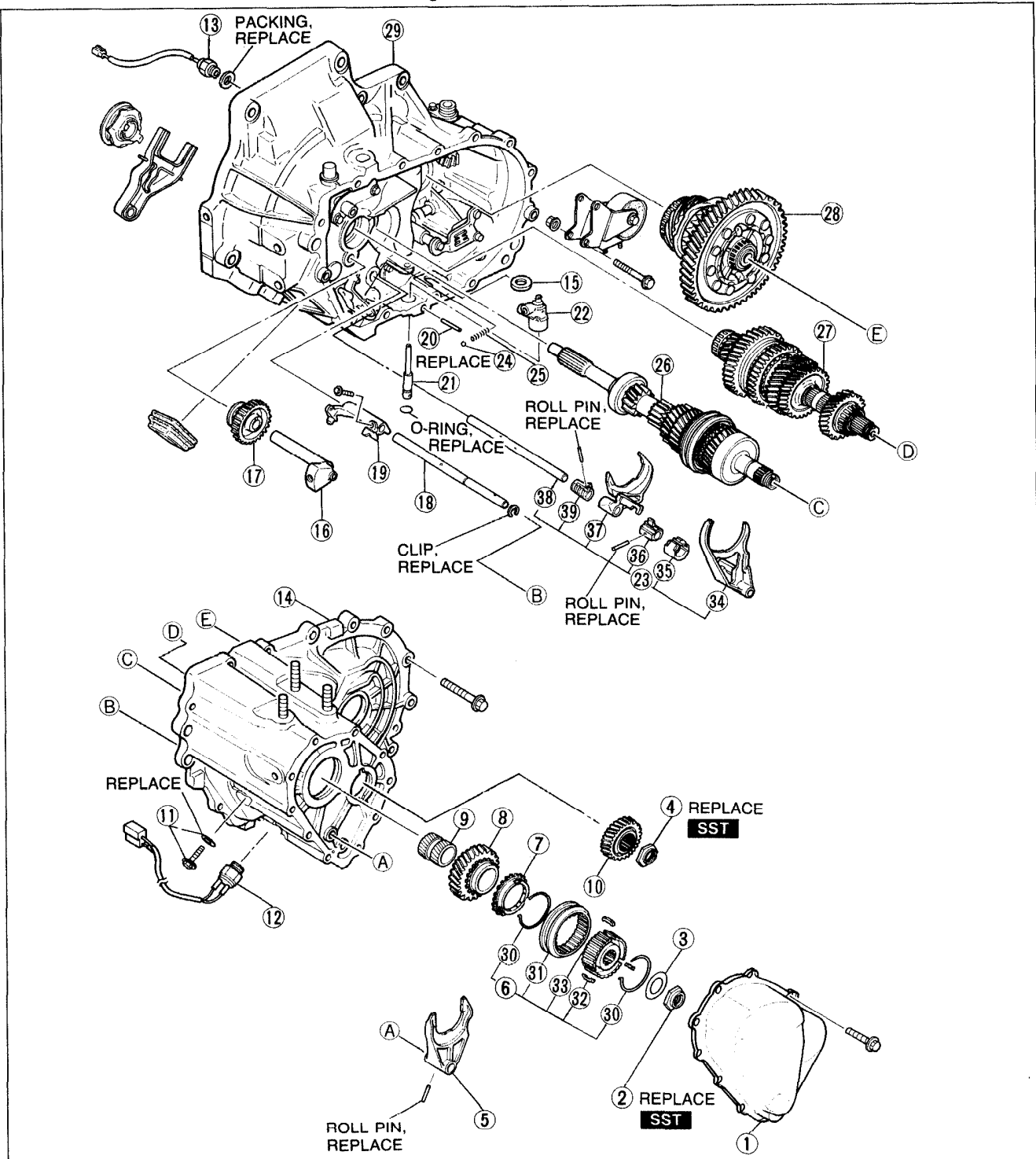

03U0J1-020

1. Rear cover		18. 5th shift rod	
2. Locknut (Primary shaft)		19. 5th shift rod end	
Disassembly Note.....	page J1-15	20. Pin	
3. Stop plate		21. Crank lever shaft	
4. Locknut (Secondary shaft)		22. Crank lever assembly	
Disassembly Note.....	page J1-15	23. Shift fork and shift rod assembly	
5. 5th shift fork		Disassembly Note.....	page J1-16
6. Clutch hub assembly (5th)		24. Steel ball	
Inspection.....	page J1-29	25. Spring	
7. Synchronizer ring (5th)		26. Primary shaft gear assembly	
Inspection.....	page J1-27	27. Secondary shaft gear assembly	
8. 5th gear		28. Differential assembly	
Inspection.....	page J1-28	29. Clutch housing	
9. Gear sleeve		30. Synchronizer spring	
Inspection.....	page J1-28	31. Clutch hub sleeve	
10. Secondary 5th gear		32. Synchronizer key	
11. Lock bolt and washer		33. Clutch hub	
12. Back-up light switch		34. 3rd/4th shift fork	
13. Neutral switch		35. Interlock sleeve	
14. Transaxle case assembly		36. Control lever	
15. Magnet		37. 1st/2nd shift fork	
16. Reverse idler shaft		38. Control rod	
17. Reverse idler gear		39. Control end	
Inspection.....	page J1-27		

03U0J1-021

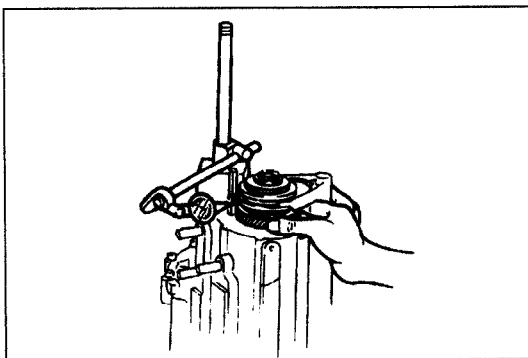

03U0J1-022

Preinspection
5th gear thrust clearance

1. Measure the 5th gear thrust clearance with a dial indicator.

Clearance: 0.06—0.26mm (0.0024—0.0102 in)
Maximum : 0.31mm (0.0122 in)

2. If the clearance exceeds the the maximum, check the contact surfaces of 5th gear and the clutch hub. Replace worn or damaged parts.

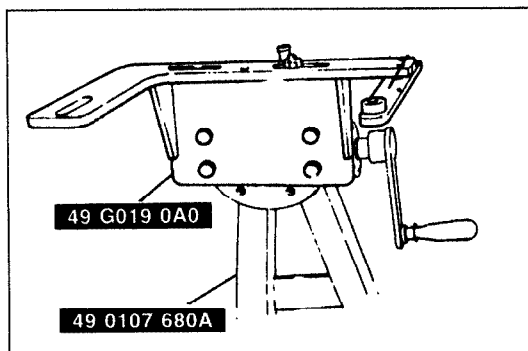

03U0J1-023

Disassembly note
Locknut

1. Mount the transaxle on the **SST**.

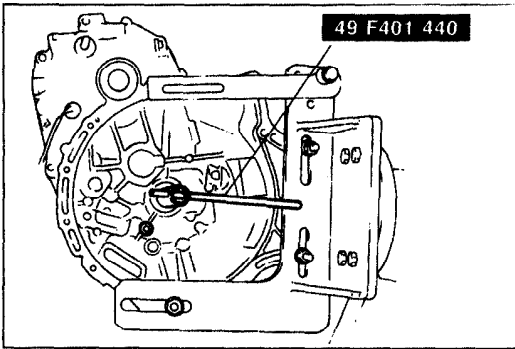

03U0J2-023

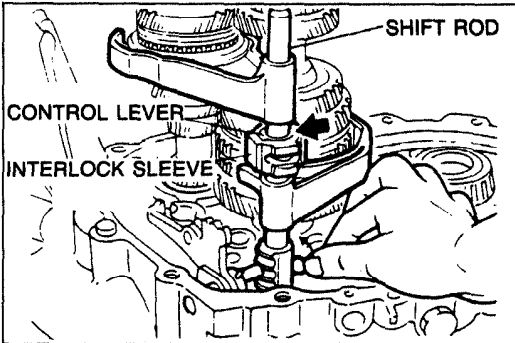

03U0J2-024

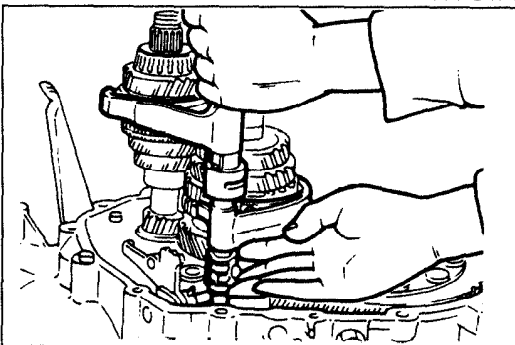

76U07A-227

2. Lock the primary shaft with the **SST**.
3. Shift to 1st or 2nd gear to lock the rotation of the primary shaft.

Caution

- Do not reuse the removed locknut.

4. Uncrimp the tabs of the locknuts.
5. Remove the locknuts from the primary and secondary shafts.

Shift fork and shift rod assembly

1. Align the ends of the interlock sleeve and of the control lever (arrow). Turn the shift rod counterclockwise.
2. While holding the 1st-2nd shift fork with one hand and the 3rd-4th shift fork with the other, raise them both at the same time and shift each of the clutch hub sleeves.
3. Lift the control end and remove the steel ball, and, at the same time, remove the shift rod from the clutch housing.
4. Separate the shift rod and shift fork assembly from each of the clutch hub sleeves.

Clutch Housing and Transaxle Case Components

Caution

- Do not remove oil seals unless necessary.

1. Disassemble in the order shown in the figure, referring to **Disassembly Note**.

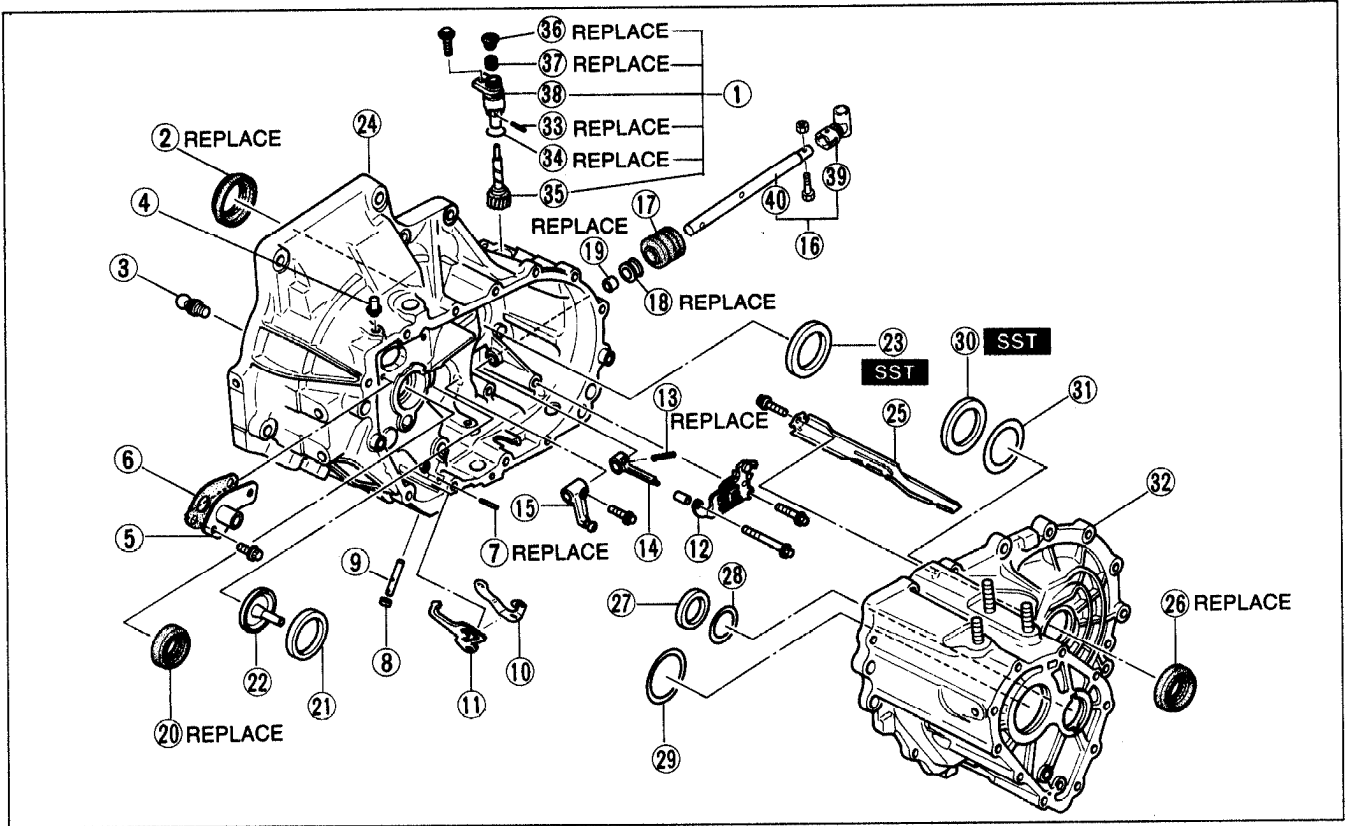

23U0J1-003

- | | | |
|--|--|--|
| 1. Speedometer driven gear assembly | 17. Boot | 28. Adjust shim |
| 2. Oil seal (Differential)
Disassembly Note
..... page J1-19 | 18. Oil seal (Change rod)
Disassembly Note
..... page J1-18 | 29. Adjust shim |
| 3. Pivot | 19. Bushing | 30. Bearing outer race
(Differential)
Disassembly Note
..... page J1-19 |
| 4. Bleeder | 20. Oil seal (Primary shaft)
Disassembly Note
..... page J1-19 | 31. Adjust shim (Differential)
Disassembly Note
..... page J1-19 |
| 5. Bleeder cover | 21. Bearing outer race
Disassembly Note
..... page J1-18 | 32. Transaxle case |
| 6. Gasket | 22. Funnel
Disassembly Note
..... page J1-18 | 33. Roll pin |
| 7. Roll pin | 23. Bearing outer race
(Differential)
Disassembly Note
..... page J1-19 | 34. O-ring |
| 8. Blind plug
Disassembly Note
..... page J1-18 | 24. Clutch housing | 35. Driven gear |
| 9. Reverse lever shaft
Disassembly Note
..... page J1-18 | 25. Oil passage | 36. Packing
37. Oil seal
(Speedometer gear case)
Disassembly Note
..... page J1-19 |
| 10. Lever set spring | 26. Oil seal (Differential)
Disassembly Note
..... page J1-19 | 38. Gear case |
| 11. Reverse lever
Inspection..... page J1-27 | 27. Bearing outer race | 39. Joint |
| 12. Guide plate assembly | | 40. Change rod |
| 13. Roll pin | | |
| 14. Selector
Replacement (On-vehicle)
..... page J1-20 | | |
| 15. Change arm | | |
| 16. Change rod assembly | | |

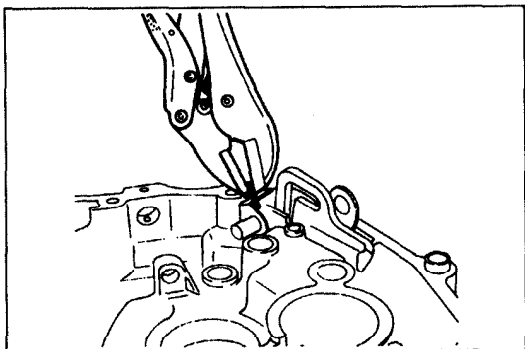

03U0J1-025

Disassembly note

Blind plug

1. Remove the roll pin with pliers.

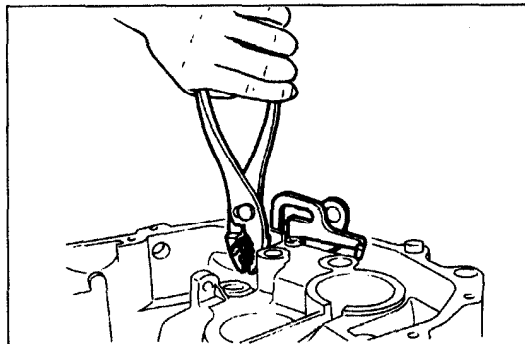

03U0J1-026

Reverse lever shaft

1. Protect the reverse lever shaft with a rag and remove the shaft with pliers.

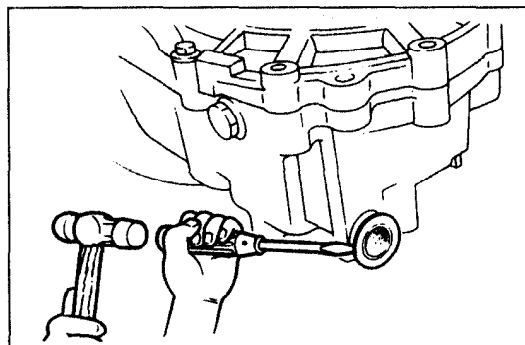

03U0J1-027

Oil seal (Change rod)

1. Remove the oil seal with a screwdriver.

Funnel and bearing outer race (Secondary shaft)

Note

- Remove the bearing outer race with a screwdriver if necessary.
 - 1) Insert a screwdriver between the clutch housing and bearing outer race.
 - 2) Pry the bearing outer race free.

03U0J1-028

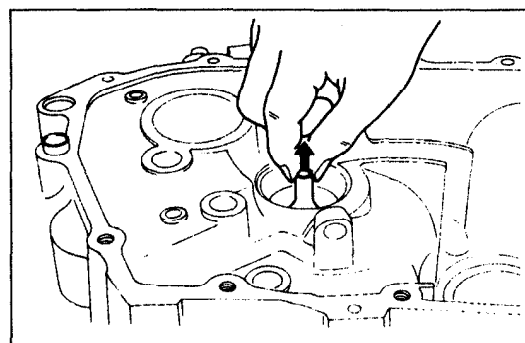

03U0J1-029

1. Remove the bearing outer race by lifting out the funnel and race together.

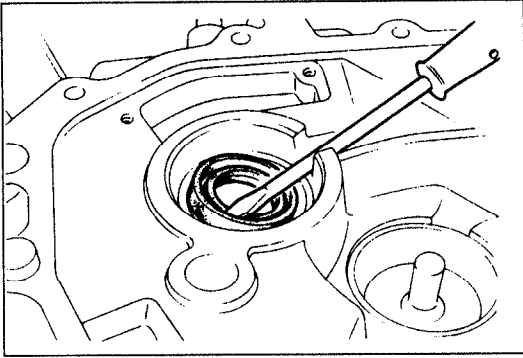

03U0J1-030

Oil seal (Primary shaft)

Caution

- Do not damage the clutch housing.

1. Remove the oil seal with a screwdriver.

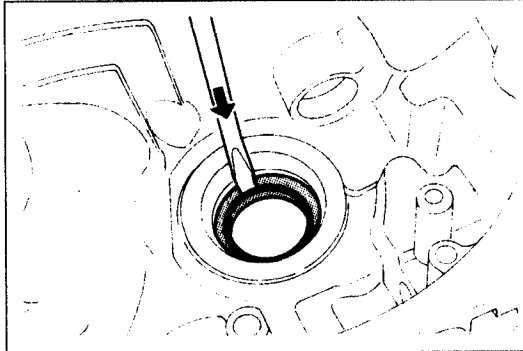

03U0J1-031

Oil seal (Differential)

1. Remove the oil seal with a screwdriver.

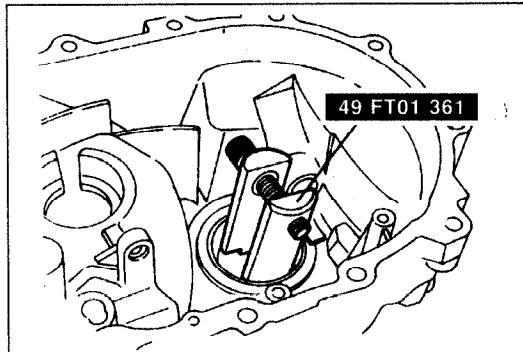

23U0J1-004

Bearing outer race (Differential)

1. Remove the bearing outer race with the **SST**.

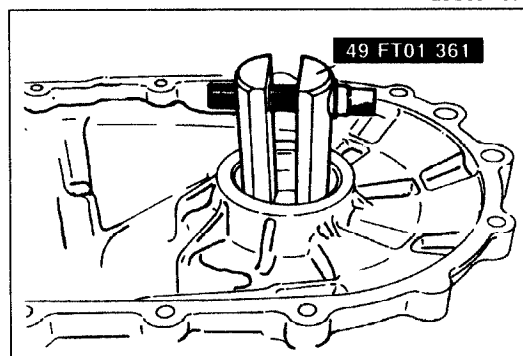

03U0J1-033

Bearing outer race and adjust shim (Differential)

1. Install the **SST** to the bearing outer race.
2. Remove the bearing outer race and adjust shim.

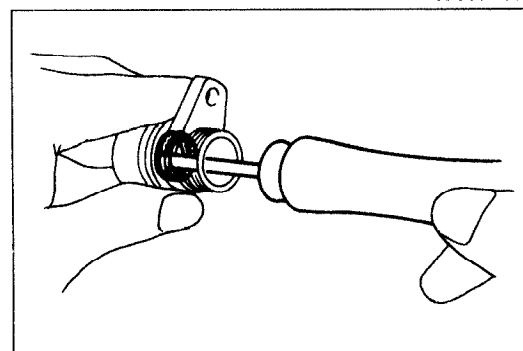

03U0J1-034

Oil seal (Speedometer gear case)

1. Remove the oil seal as shown in the figure.

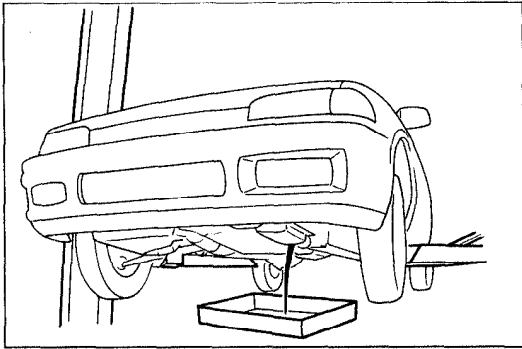

03U0J2-028

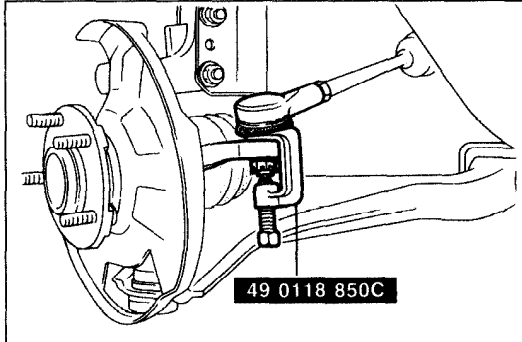

03U0J1-035

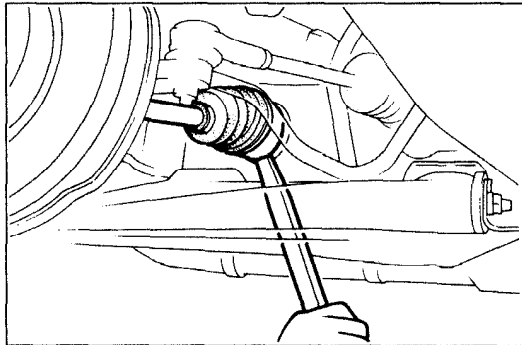

03U0J1-036

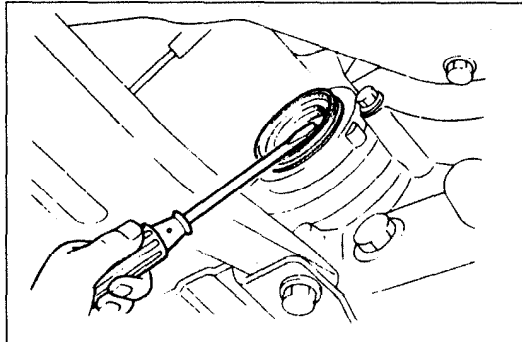

03U0J2-031

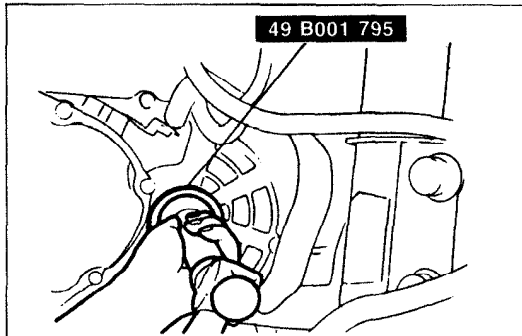

03U0J1-037

Oil seal Replacement (On-vehicle)

Jack up the vehicle and support it with safety stands. Drain the transaxle oil. Next, use the following procedure to replace the driveshaft oil seal:

1. Remove the front wheel.
2. Remove the splash shield.
3. Separate the front stabilizer from the lower arm.

Caution

- Do not damage the dust boots.

4. Remove the clinch bolt and pull the lower arm downward. Separate the knuckle from the lower arm ball joint.
5. Loosen the nut and disconnect the tie-rod end with the **SST**.

Caution

- Do not subject the tripod joint to shock when removing the driveshaft.

6. Disconnect the driveshaft from the transaxle by prying with a bar inserted between the outer ring and the transaxle.
7. Suspend the driveshaft with a rope.

8. Remove the oil seal with a screwdriver.

Note

- Tap in until the oil seal installer contacts the case.
- Coat the oil seal lip with transaxle oil.

9. Tap the new oil seal into the transaxle case with the **SST**.

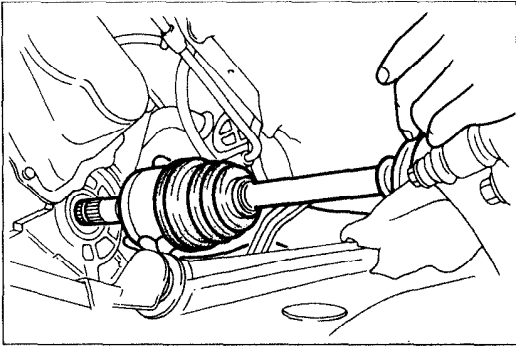

03U0J2-032

10. Replace the driveshaft end clip with a new one. Insert the driveshaft with the end-gap of the clip facing upward.

Primary Shaft Assembly

1. Measure the thrust clearances of all gears before disassembly, referring to **Preinspection**.
2. Disassemble in the order shown in the figure, referring to **Disassembly Note**.

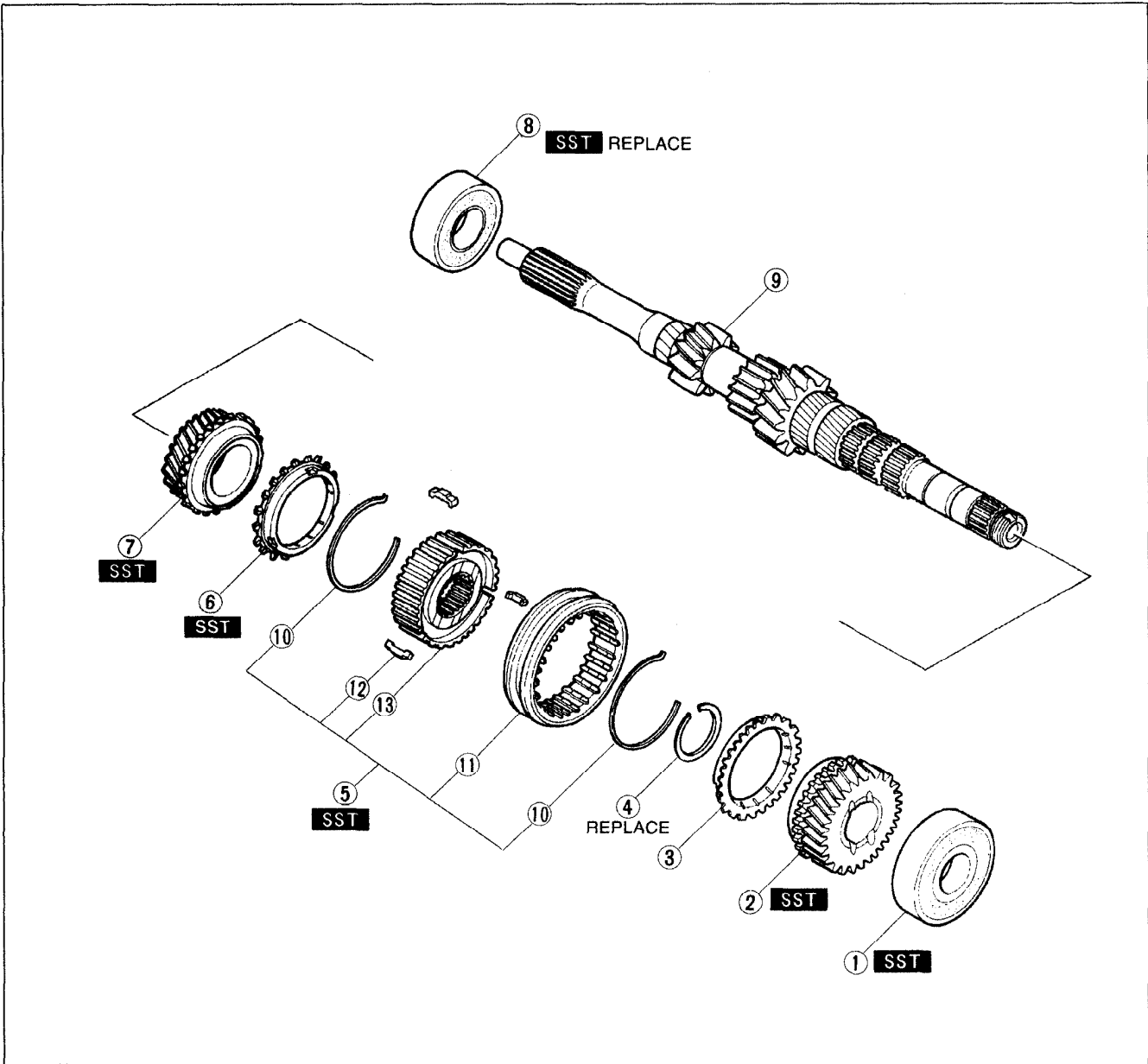

03U0J1-038

- | | |
|----------------------------------|----------------------------------|
| 1. Bearing | 7. 3rd gear |
| Disassembly Note..... page J1-23 | Disassembly Note..... page J1-23 |
| Inspection..... page J1-28 | Inspection..... page J1-28 |
| 2. 4th gear | 8. Bearing |
| Disassembly Note..... page J1-23 | Disassembly Note..... page J1-23 |
| Inspection..... page J1-28 | 9. Primary shaft |
| 3. Synchronizer ring (4th) | Inspection..... page J1-27 |
| Inspection..... page J1-27 | 10. Synchronizer spring |
| 4. Retaining ring | 11. Clutch hub sleeve |
| 5. Clutch hub assembly (3rd/4th) | 12. Synchronizer key |
| Disassembly Note..... page J1-23 | 13. Clutch hub |
| Inspection..... page J1-29 | |
| 6. Synchronizer ring (3rd) | |
| Disassembly Note..... page J1-23 | |
| Inspection..... page J1-27 | |

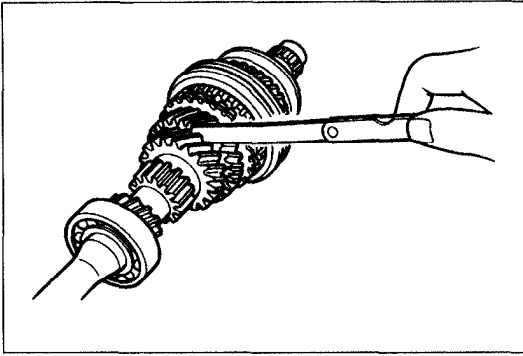

03U0J1-039

Preinspection

3rd gear thrust clearance

1. Measure the clearance between 3rd gear and 2nd gear.

Clearance: 0.06—0.21mm (0.002—0.008 in)

Maximum: 0.26mm (0.010 in)

2. If the clearance exceeds the maximum, check the contact surfaces of the 3rd gear, 2nd gear and clutch hub (3rd/4th). Replace worn or damaged parts.

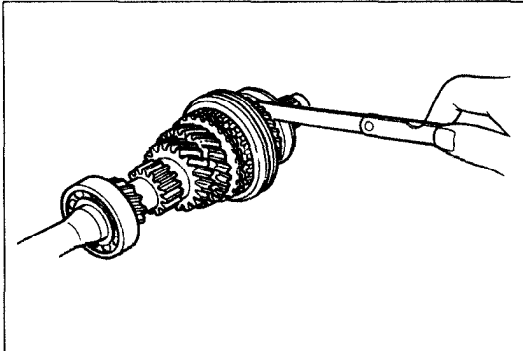

03U0J1-040

4th gear thrust clearance

1. Measure the clearance between 4th gear and the ball bearing.

Clearance: 0.21—0.61mm (0.008—0.024 in)

Maximum: 0.66mm (0.026 in)

2. If the clearance exceeds the maximum, check the contact surfaces of the 4th gear, ball bearing, and clutch hub (3rd/4th). Replace worn or damaged parts.

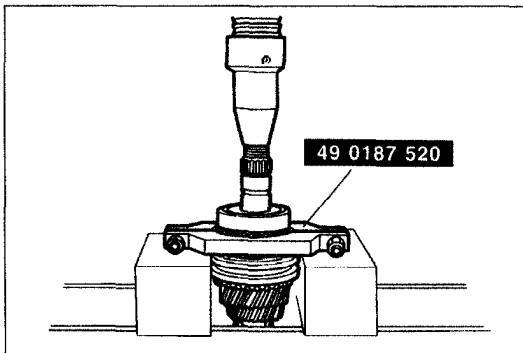

03U0J1-041

Disassembly note

Bearing and 4th gear

Caution

- Hold the shaft with one hand so that it does not fall.

1. Remove the ball bearing and 4th gear with the **SST**.

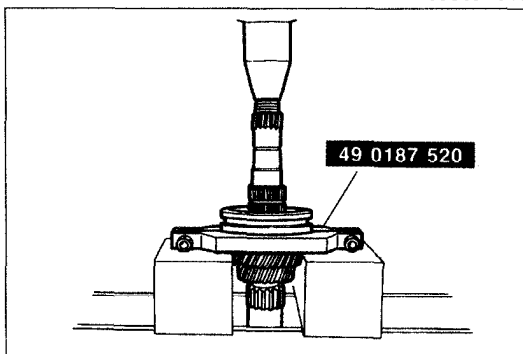

03U0J1-042

Clutch hub assembly (3rd/4th), synchronizer ring (3rd) and 3rd gear

Caution

- Hold the shaft with one hand so that it does not fall.

1. Remove the retaining ring.
2. Remove the clutch hub assembly (3rd/4th), synchronizer ring (3rd) and 3rd gear with the **SST**.

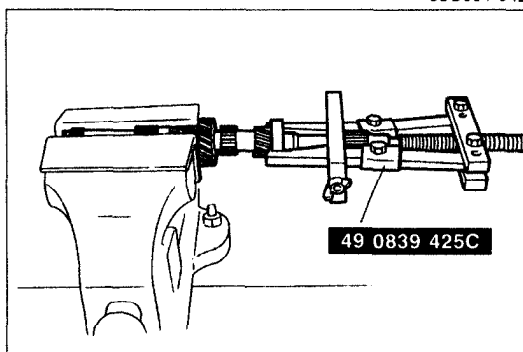

03U0J1-043

Bearing

1. Remove the bearing with the **SST**.

Secondary Shaft Assembly

1. Measure the thrust clearance of 1st gear and 2nd gear, referring to **Preinspection**.
2. Disassemble in the order shown in the figure, referring to **Disassembly Note**.

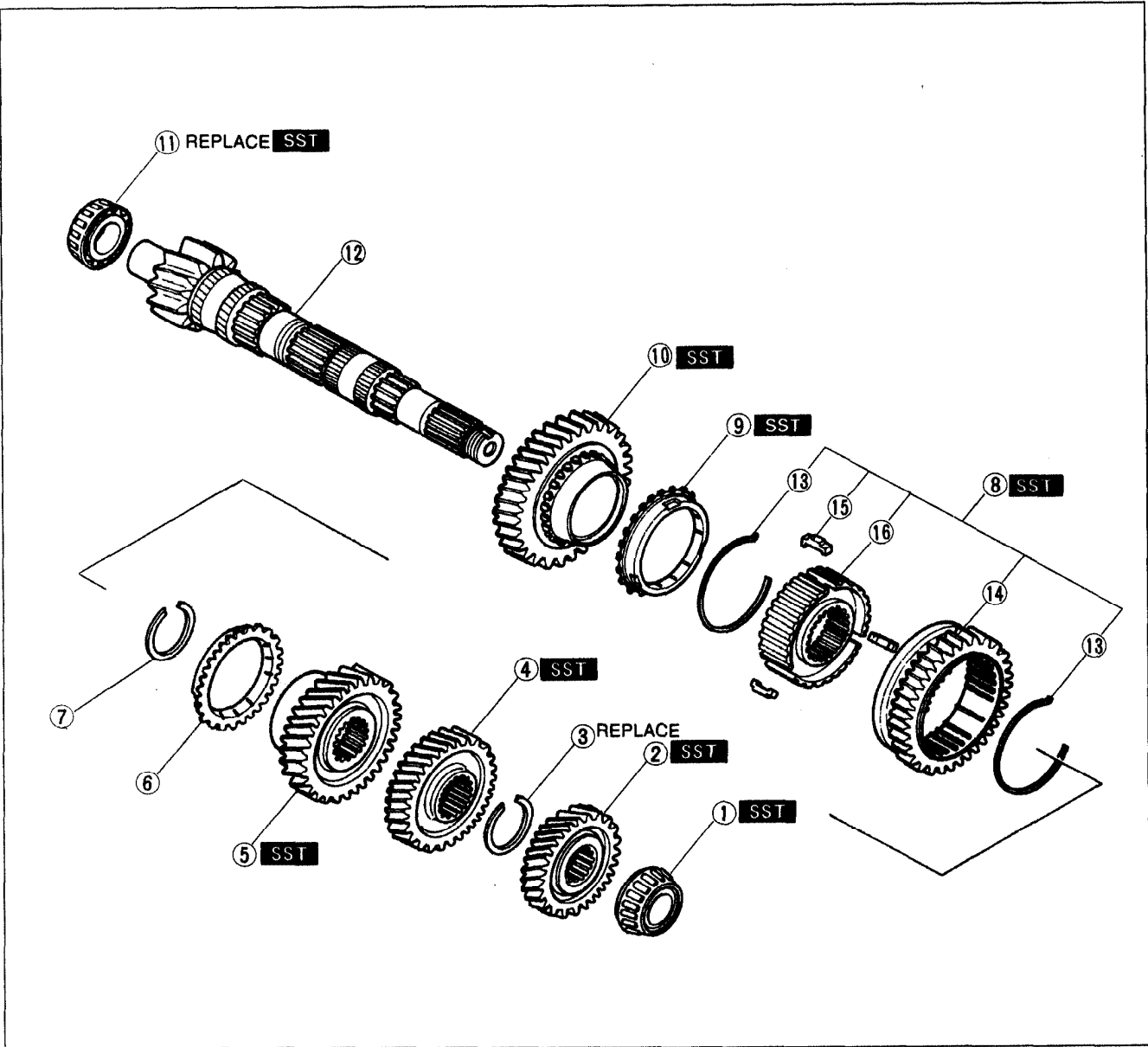

23U0J1-005

- | | |
|--|--|
| 1. Bearing inner race
Disassembly Note..... page J1-25 | 9. Synchronizer ring (1st)
Disassembly Note..... page J1-25
Inspection..... page J1-27 |
| 2. Secondary 4th gear
Disassembly Note..... page J1-25 | 10. 1st gear
Disassembly Note..... page J1-25
Inspection..... page J1-29 |
| 3. Retaining ring | 11. Bearing inner race
Disassembly Note..... page J1-26 |
| 4. Secondary 3rd gear
Disassembly Note..... page J1-25 | 12. Secondary shaft
Inspection..... page J1-28 |
| 5. 2nd gear
Disassembly Note..... page J1-25
Inspection..... page J1-29 | 13. Synchronizer spring |
| 6. Synchronizer ring (2nd)
Inspection..... page J1-27 | 14. Clutch hub sleeve |
| 7. Retaining ring | 15. Synchronizer key |
| 8. Clutch hub assembly (1st/2nd)
Disassembly Note..... page J1-25
Inspection..... page J1-29 | 16. Clutch hub |

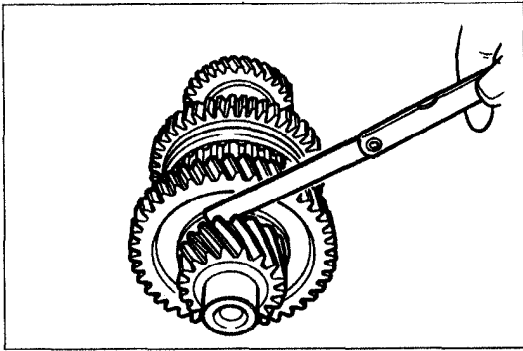

03U0J1-045

Preinspection

1st gear thrust clearance

1. Measure the clearance between 1st gear and the differential drive gear.

Clearance: 0.05—0.28mm (0.002—0.011 in)
Maximum: 0.33mm (0.013 in)

2. If the clearance exceeds the maximum, check the contact surfaces of the 1st gear, differential drive gear of the secondary shaft gear, and clutch hub assembly (1st/2nd). Replace worn or damaged parts.

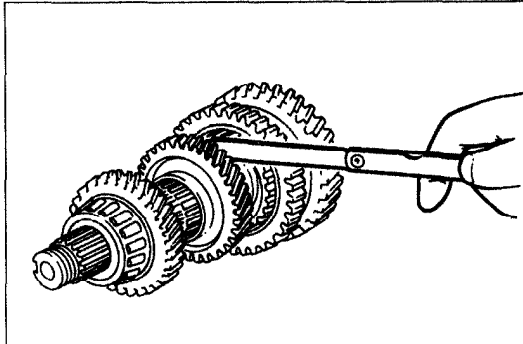

03U0J1-046

2nd gear thrust clearance

1. Measure the clearance between 2nd gear and secondary 3rd gear.

Clearance: 0.18—0.51mm (0.007—0.020 in)
Maximum: 0.56mm (0.022 in)

2. If the clearance exceeds the maximum, check the contact surfaces of the 2nd gear, secondary 3rd gear, and clutch hub assembly (1st/2nd). Replace worn or damaged parts.

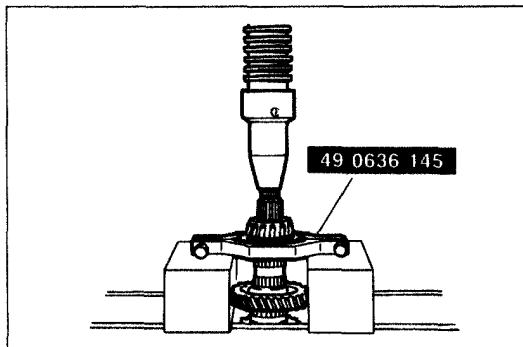

03U0J1-047

Disassembly note

Bearing inner race and secondary 4th gear

Caution

- Hold the shaft with one hand so that it does not fall.

1. Remove the bearing inner race and secondary 4th gear with the **SST**.

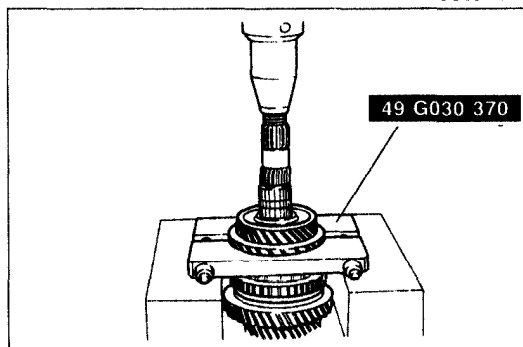

03U0J1-048

Secondary 3rd gear and 2nd gear

Caution

- Hold the shaft with one hand so that it does not fall.

1. Remove the retaining ring.
2. Remove the secondary 3rd gear and 2nd gear with the **SST**.

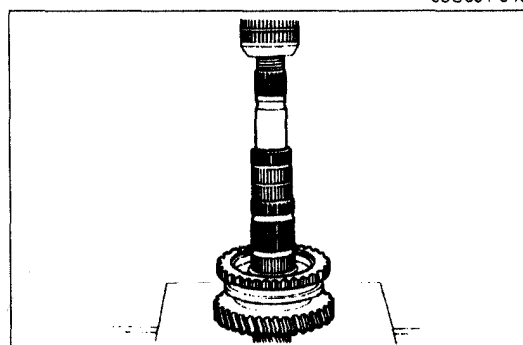

03U0J1-049

Clutch hub assembly (1st/2nd), synchronizer ring (1st) and 1st gear

Caution

- Hold the shaft with one hand so that it does not fall.

1. Remove the clutch hub assembly (1st/2nd), synchronizer ring (1st) and 1st gear with the **SST**.

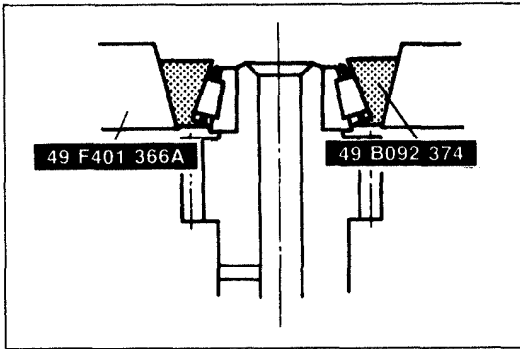

03U0J1-050

Bearing inner race (Secondary shaft end)

Caution

- Hold the shaft with one hand so that it does not fall.

1. Remove the bearing inner race with the **SST**.

INSPECTION

Inspect all parts and repair or replace as necessary.

03U0J1-051

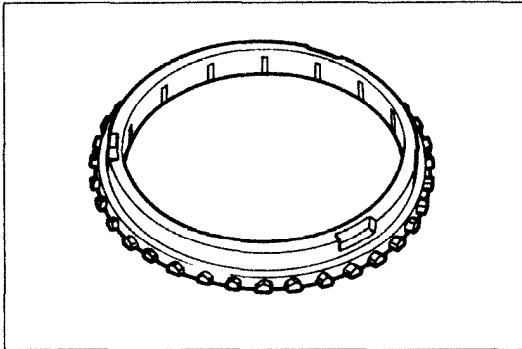

03U0J1-052

Synchronizer Ring

1. Inspect individual synchronizer ring teeth for damage, wear, cracks.
2. Inspect taper surface for wear or cracks.

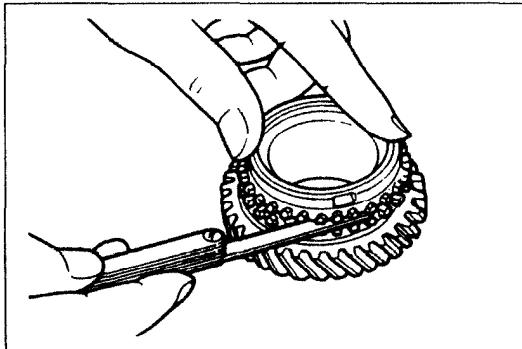

03U0J1-053

Note

- Set the synchronizer ring squarely in the gear; then measure around the circumference.

3. Measure the clearance between the synchronizer ring and flank surface of the gear.

Standard clearance: 1.12—1.88mm (0.044—0.074 in)
Minimum: 0.8mm (0.032 in)

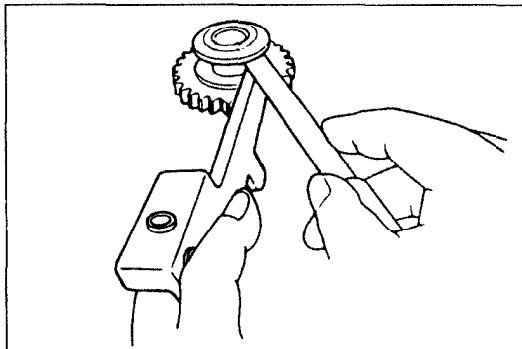

03U0J1-054

Reverse Idler Gear and Reverse Lever

1. Inspect gear teeth for damage, wear, and cracks.
2. Measure the clearance between the reverse idler gear bushing and the reverse lever.

Standard clearance: 0.10—0.32mm (0.004—0.013 in)
Maximum: 0.37mm (0.015 in)

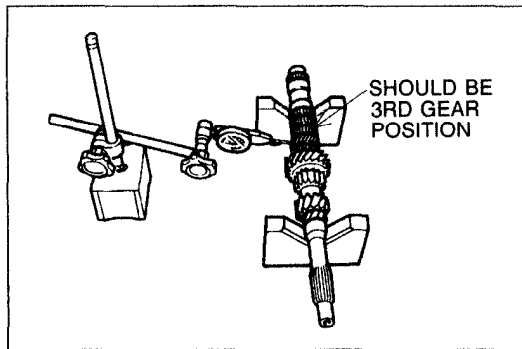

13U0J1-006

Primary Shaft

Note

- If the shaft gear is replaced, adjust the bearing preload. (Refer to page J1-37.)

1. Inspect the shaft gear runout.

Maximum runout: 0.05mm (0.002 in)

2. Inspect the splines for damage and wear.
3. Inspect the gear teeth for damage, wear, and cracks.

3rd Gear, 4th Gear, 5th Gear, and Gear Sleeve (5th gear)

1. Measure the clearance between the shaft gears and gears.

Oil Clearance

mm (in)

	Shaft (A) (outer diameter)	Gear (B) (inner diameter)	Sleeve (C) (outer diameter)	Oil (D) Clearance
3rd Gear	35.15—35.17 (1.384—1.385)	35.20—35.22 (1.386—1.387)	—	(D) = (B) - (A) 0.03—0.07 (0.001—0.003)
4th Gear	31.95—31.97 (1.258—1.259)	32.00—32.02 (1.260—1.261)	—	(D) = (B) - (A) 0.03—0.07 (0.001—0.003)
5th Gear	—	34.00—34.02 (1.338—1.339)	33.94—33.97 (1.336—1.337)	(D) = (B) - (C) 0.03—0.08 (0.001—0.003)

2. Inspect the synchronizer cones for wear.
3. Inspect the gear teeth for damage, wear, and cracks.

Bearing

1. Inspect for damage or rough rotation.

Secondary Shaft

Note

- If the shaft gear is replaced, adjust the bearing preload. (Refer to page J1-37.)

1. Inspect the shaft gear runout.

Maximum runout: 0.015mm (0.001 in)

2. Inspect the gear teeth for damage, wear, and cracks.

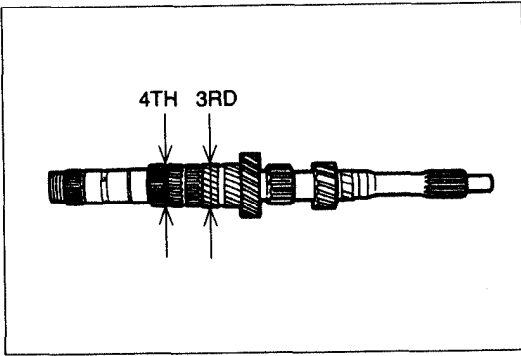

03U0J1-057

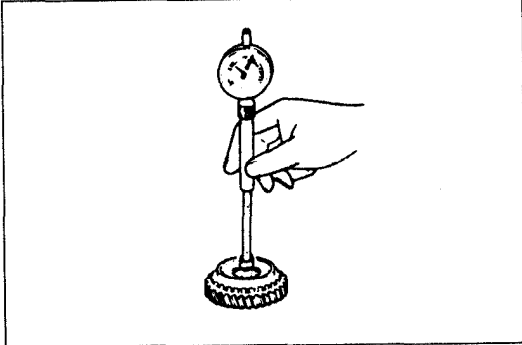

03U0J1-058

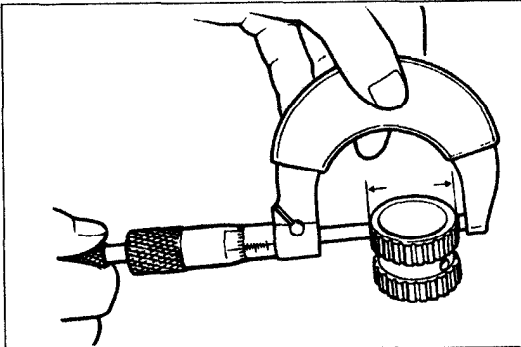

03U0J1-059

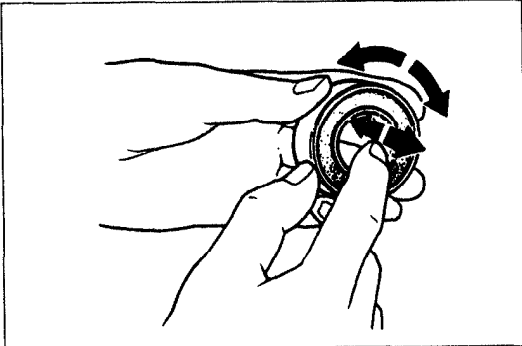

9MU0JX-063

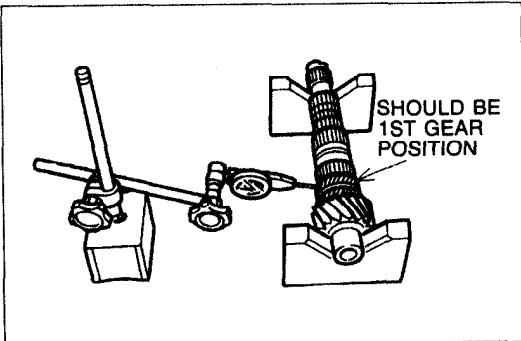

03U0J1-060

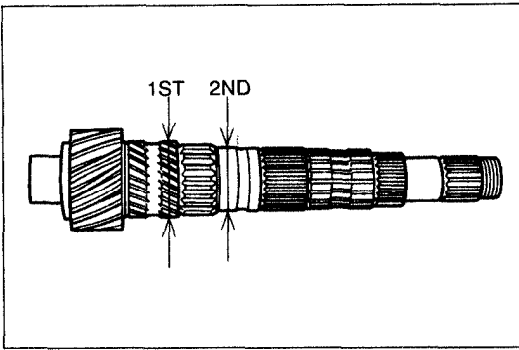

03U0J1-061

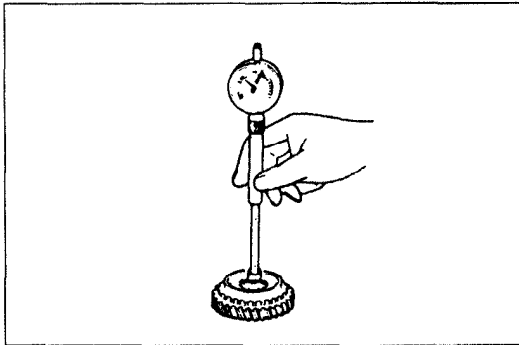

03U0J1-062

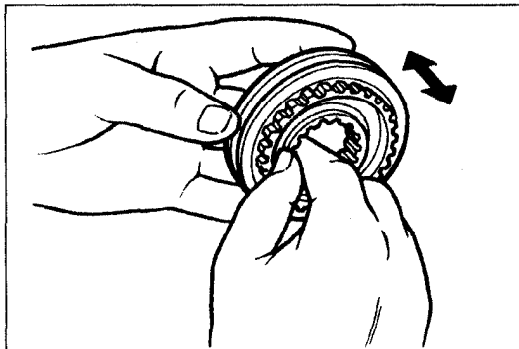

9MU0JX-059

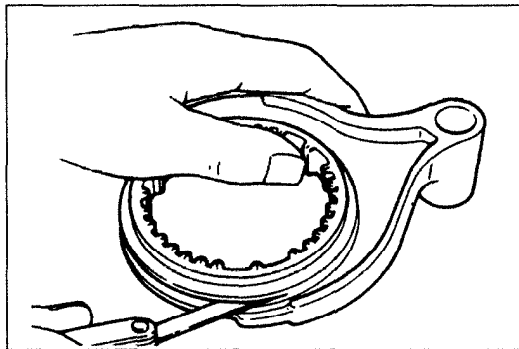

03U0J1-055

1st Gear and 2nd Gear

1. Measure the clearance between the shaft gears and the gears.

Oil Clearance

mm (in)

	Shaft (A) (outer diameter)	Gear (B) (inner diameter)	Sleeve (C) (outer diameter)	Oil (D) Clearance
1st Gear	39.45—39.47 (1.553—1.554)	39.50—39.52 (1.555—1.556)	—	(D) = (B) - (A) 0.03—0.07 (0.001—0.003)
2nd Gear	35.15—35.17 (1.384—1.385)	35.20—35.22 (1.386—1.387)	—	(D) = (B) - (A) 0.03—0.07 (0.001—0.003)

2. Inspect the synchronizer cones for wear.
3. Inspect the gear teeth for damage, wear, and cracks.

Clutch hub assembly

1. Inspect the clutch hub sleeve and hub operation.
2. Inspect the individual gear teeth for damage, wear, and cracks.
3. Inspect the synchronizer key for damage, wear, and cracks.

4. Measure the clearance between the hub sleeve and the shift fork.

mm (in)

	Standard clearance	Maximum
1st/2nd	0.10—0.36 (0.004—0.014)	0.86 (0.034)
3rd/4th	0.20—0.50 (0.008—0.020)	1.00 (0.039)
5th	0.40—0.75 (0.016—0.030)	1.25 (0.049)

ASSEMBLY

Precaution

1. All O-rings and gaskets must be replaced with the new ones included in the overhaul kit.
2. Verify that all parts are completely clean before assembly.
3. Assemble parts within 10 minutes after applying sealant.
Allow all sealant to cure at least 30 minutes after assembly before filling the transaxle with transaxle oil.
4. The bearing outer race and bearing inner race must be replaced as a unit.

03U0J1-063

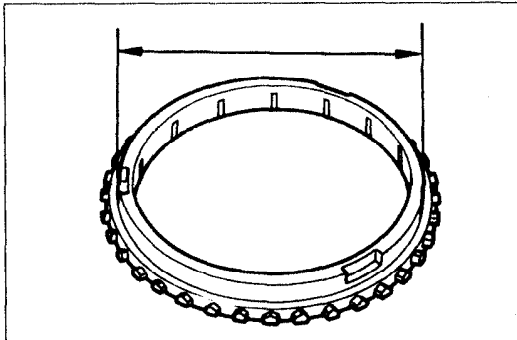

03U0J1-064

Clutch hub assembly

Note

- Synchronizer ring diameters are as follows.

mm (in)

1st and 2nd	61.7 (2.429)
3rd and 4th	61.7 (2.429)
5th	49.7 (1.957)

- Synchronizer key dimensions are as follows.

mm (in)

	①	②	③
1st/2nd	19.00 (0.748)	4.25 (0.167)	5.00 (0.197)
3rd/4th	17.00 (0.669)	4.25 (0.167)	5.00 (0.197)
5th	17.00 (0.669)	5.55 (0.219)	5.00 (0.197)

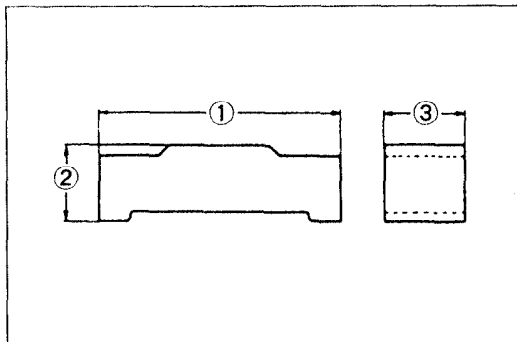

03U0J1-065

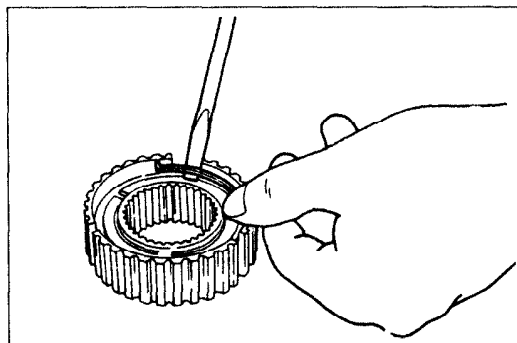

03U0J1-066

1. Install the synchronizer key springs in the clutch hub with the hooks in the grooves to hold the three synchronizer keys in place.

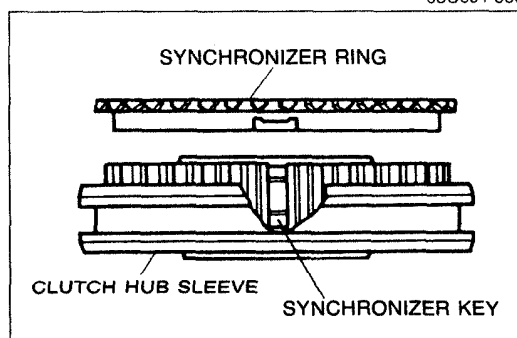

03U0J1-067

2. Align the synchronizer ring grooves with the synchronizer key during assembly.

Secondary Shaft Assembly

1. Assemble in the order shown in the figure, referring to **Assembly Note**.

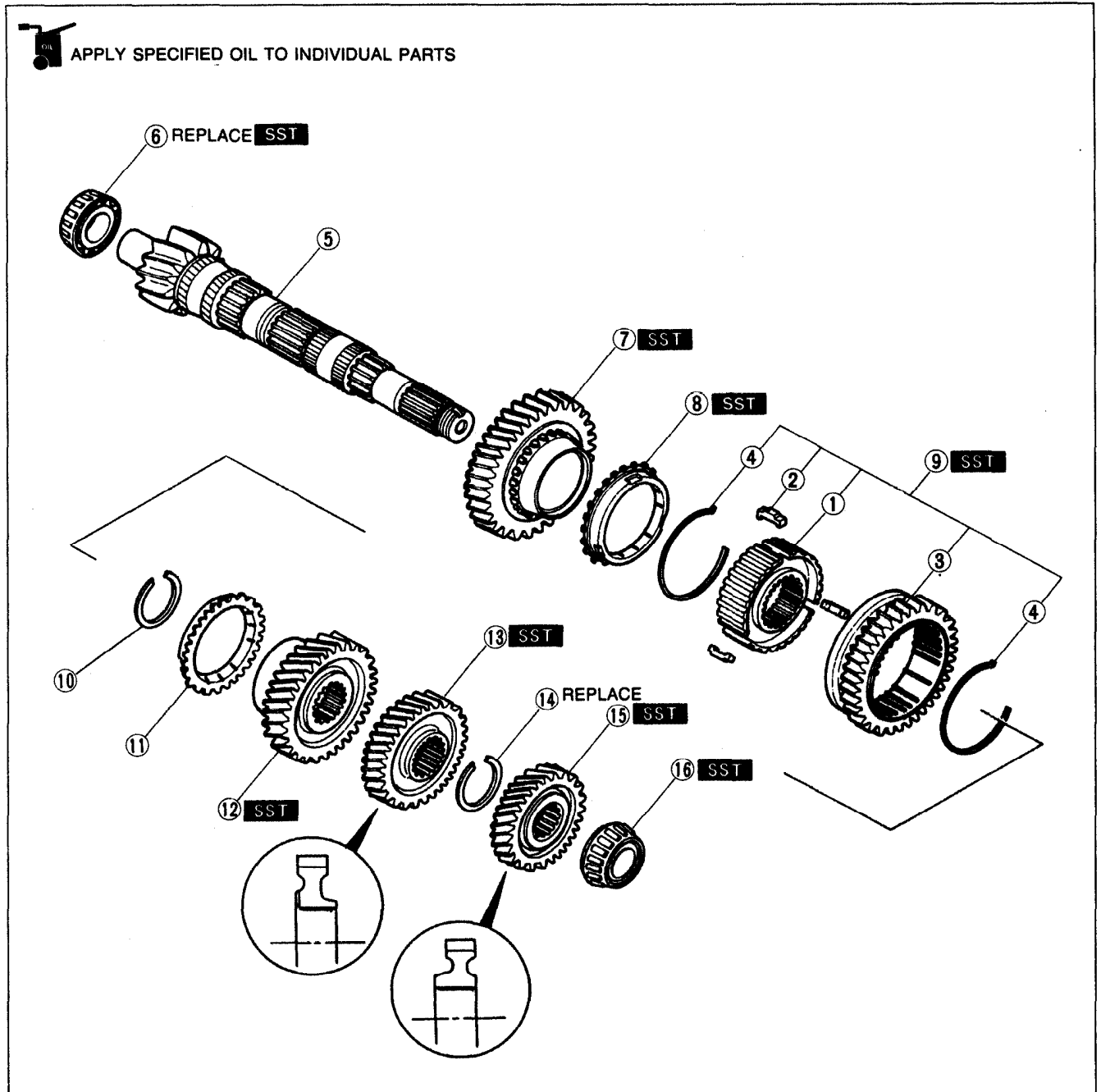

23U0J1-006

- | | |
|---|--|
| 1. Clutch hub | 10. Retaining ring |
| 2. Synchronizer key | 11. Synchronizer ring (2nd)
Assembly Note..... page J1-32 |
| 3. Clutch hub sleeve | 12. 2nd gear
Assembly Note..... page J1-32 |
| 4. Synchronizer spring | 13. Secondary 3rd gear
Assembly Note..... page J1-32 |
| 5. Secondary shaft | 14. Retaining ring |
| 6. Bearing inner race
Assembly Note..... page J1-32 | 15. Secondary 4th gear
Assembly Note..... page J1-32 |
| 7. 1st gear
Assembly Note..... page J1-32 | 16. Bearing inner race
Assembly Note..... page J1-32 |
| 8. Synchronizer ring (1st)
Assembly Note..... page J1-32 | |
| 9. Clutch hub assembly (1st/2nd)
Assembly Note..... page J1-32 | |

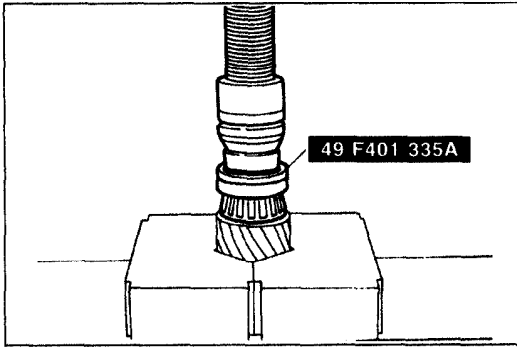

03U0J1-069

Assembly note Bearing inner race

1. Install the new bearing inner race with the **SST**.

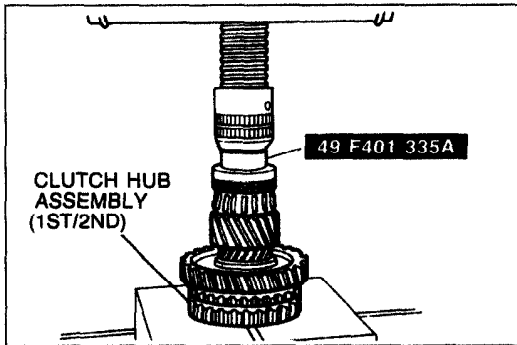

03U0J1-070

1st gear, synchronizer ring (1st) and clutch hub assembly (1st/2nd)

1. Install the 1st gear, synchronizer ring (1st) and clutch hub assembly (1st/2nd) with the **SST**.

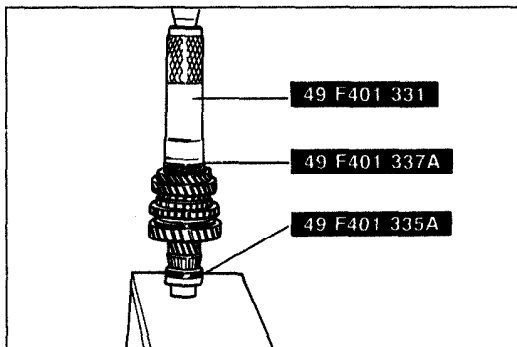

03U0J1-071

Synchronizer ring (2nd), 2nd gear, and secondary 3rd gear

1. Install the synchronizer ring (2nd), 2nd gear, and secondary 3rd gear with the **SST**.

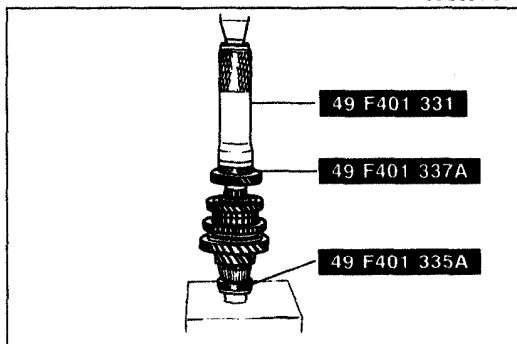

03U0J1-072

Secondary 4th gear

1. Install the secondary 4th gear with the **SST**.

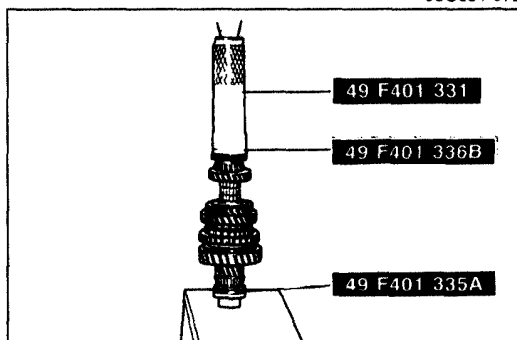

03U0J1-073

Bearing inner race (4th gear)

1. Install the new bearing inner race with the **SST**.

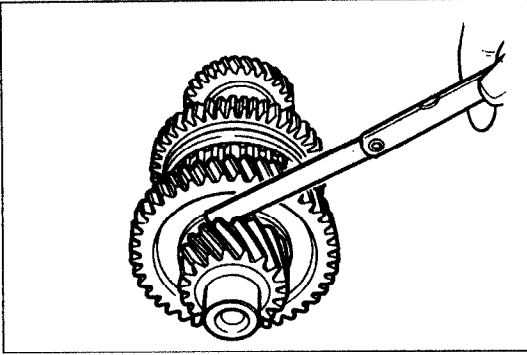

03U0J1-074

2. Measure the clearance between 1st gear and the differential drive gear.

Clearance: 0.05—0.28mm (0.002—0.011 in)
Maximum: 0.33mm (0.013 in)

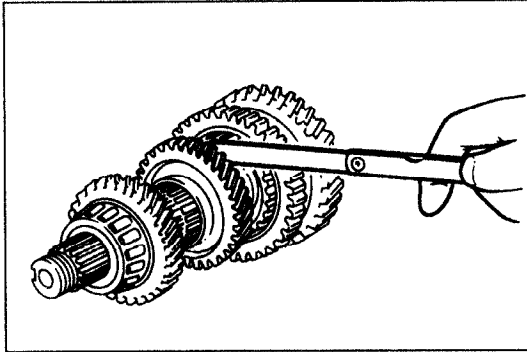

03U0J1-075

3. Measure the clearance between 2nd gear and the secondary 3rd gear.

Clearance: 0.18—0.51mm (0.007—0.020 in)
Maximum: 0.56mm (0.022 in)

4. If not as specified, reassemble the secondary shaft assembly.

Primary Shaft Assembly

1. Assemble in the order shown in the figure, referring to **Assembly Note**.

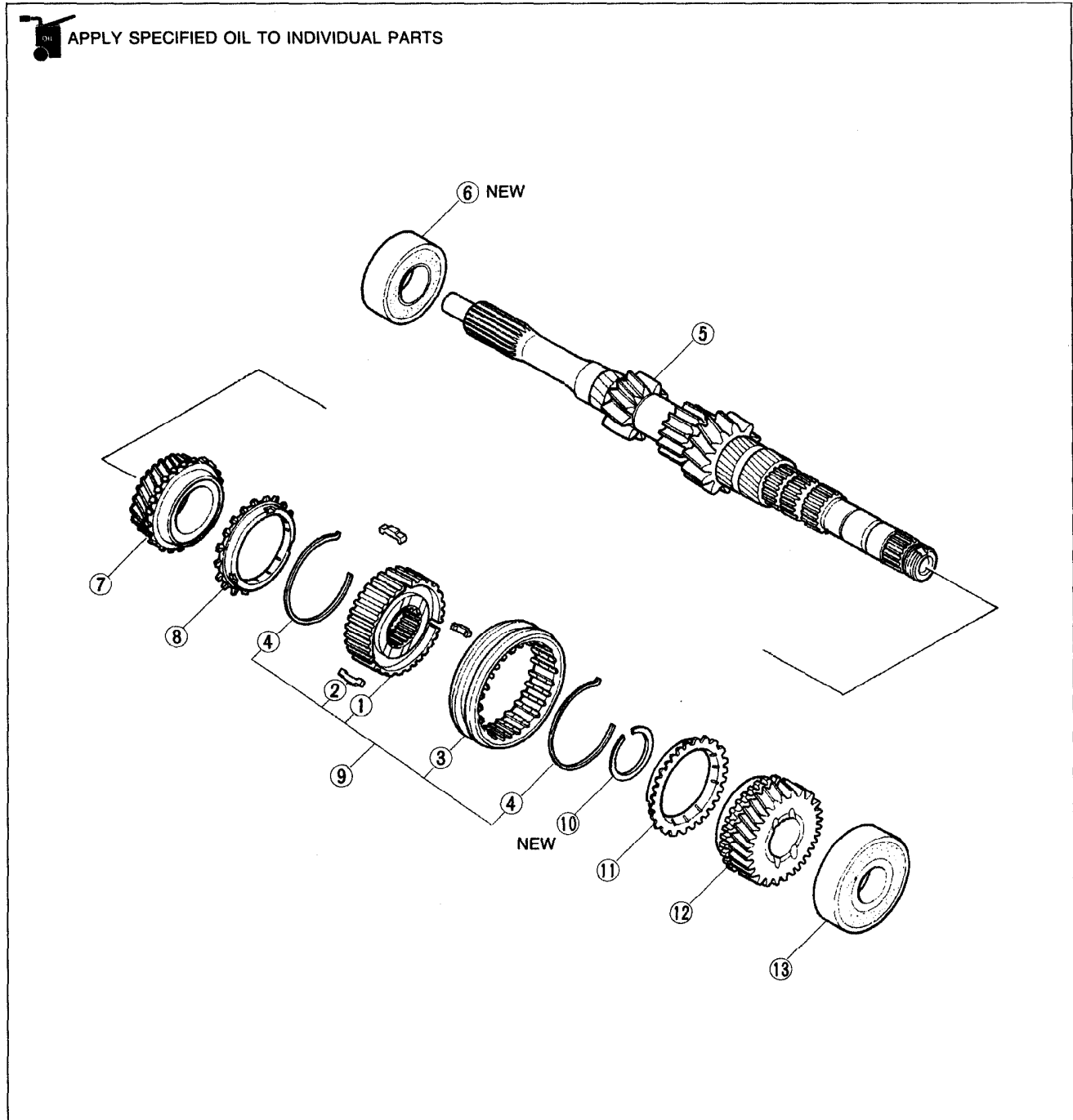

23U0J1-007

- | | |
|-------------------------------|----------------------------------|
| 1. Clutch hub | 9. Clutch hub assembly (3rd/4th) |
| 2. Synchronizer key | Assembly Note..... page J1-35 |
| 3. Clutch hub sleeve | 10. Retaining ring |
| 4. Synchronizer spring | 11. Synchronizer ring (4th) |
| 5. Primary shaft | Assembly Note..... page J1-35 |
| 6. Bearing | 12. 4th gear |
| Assembly Note..... page J1-35 | Assembly Note..... page J1-35 |
| 7. 3rd gear | 13. Bearing |
| Assembly Note..... page J1-35 | Assembly Note..... page J1-35 |
| 8. Synchronizer ring (3rd) | |
| Assembly Note..... page J1-35 | |

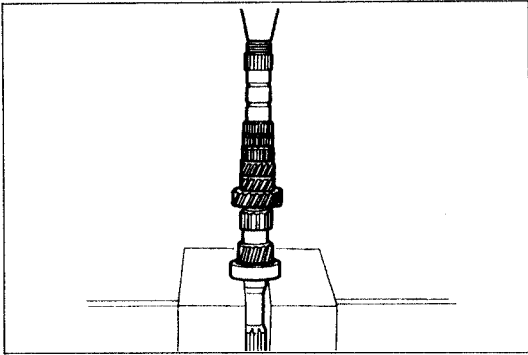

03U0J1-077

Assembly note

Bearing

1. Install the bearing with a press.

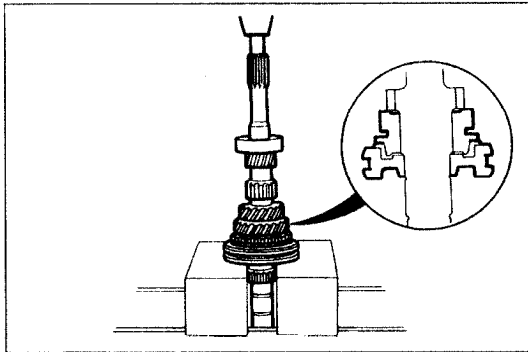

03U0J1-078

3rd gear, synchronizer ring (3rd), and clutch hub assembly (3rd/4th)

Caution

- Apply transaxle oil to the bore of 3rd gear.

1. Turn the primary shaft over and install the 3rd gear, synchronizer ring (3rd), and clutch hub assembly (3rd/4th) with a press.

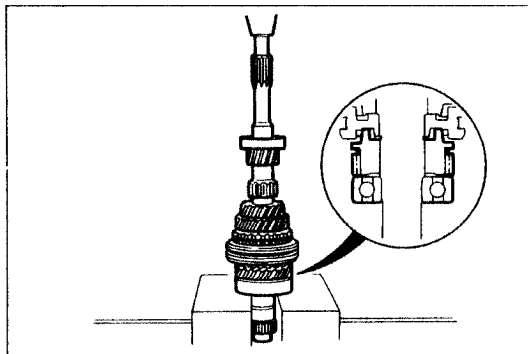

03U0J1-079

Synchronizer ring (4th), 4th gear, and bearing

1. Install the retaining ring.
2. Install the synchronizer ring (4th), 4th gear, and ball bearing with a press.

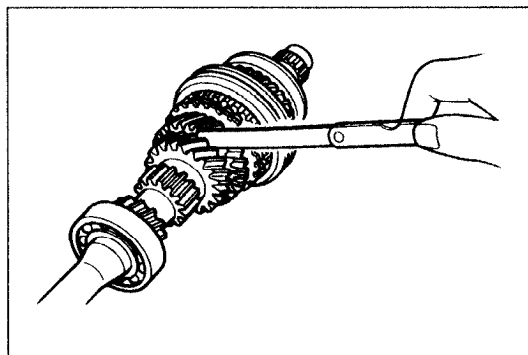

03U0J1-080

3. Measure the clearance between 3rd gear and 2nd gear.

Clearance: 0.06—0.21mm (0.002—0.008 in)
Maximum: 0.26mm (0.010 in)

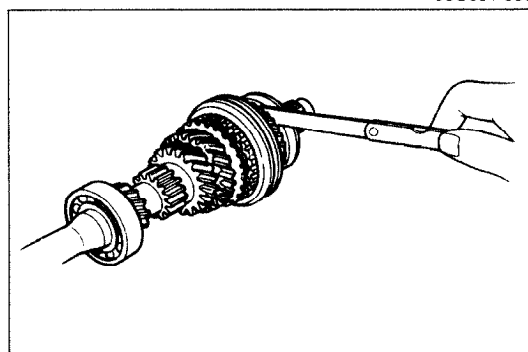

03U0J1-081

4. Measure the clearance between 4th gear and the ball bearing.

Clearance: 0.21—0.61mm (0.008—0.024 in)
Maximum: 0.66mm (0.026 in)

5. If not as specified, reassemble the primary shaft assembly.

Clutch Housing and Transaxle Case Components

1. Select the adjust shim(s), referring to **Shim selection**.
2. Assemble in the order shown in the figure, referring to **Assembly Note**.

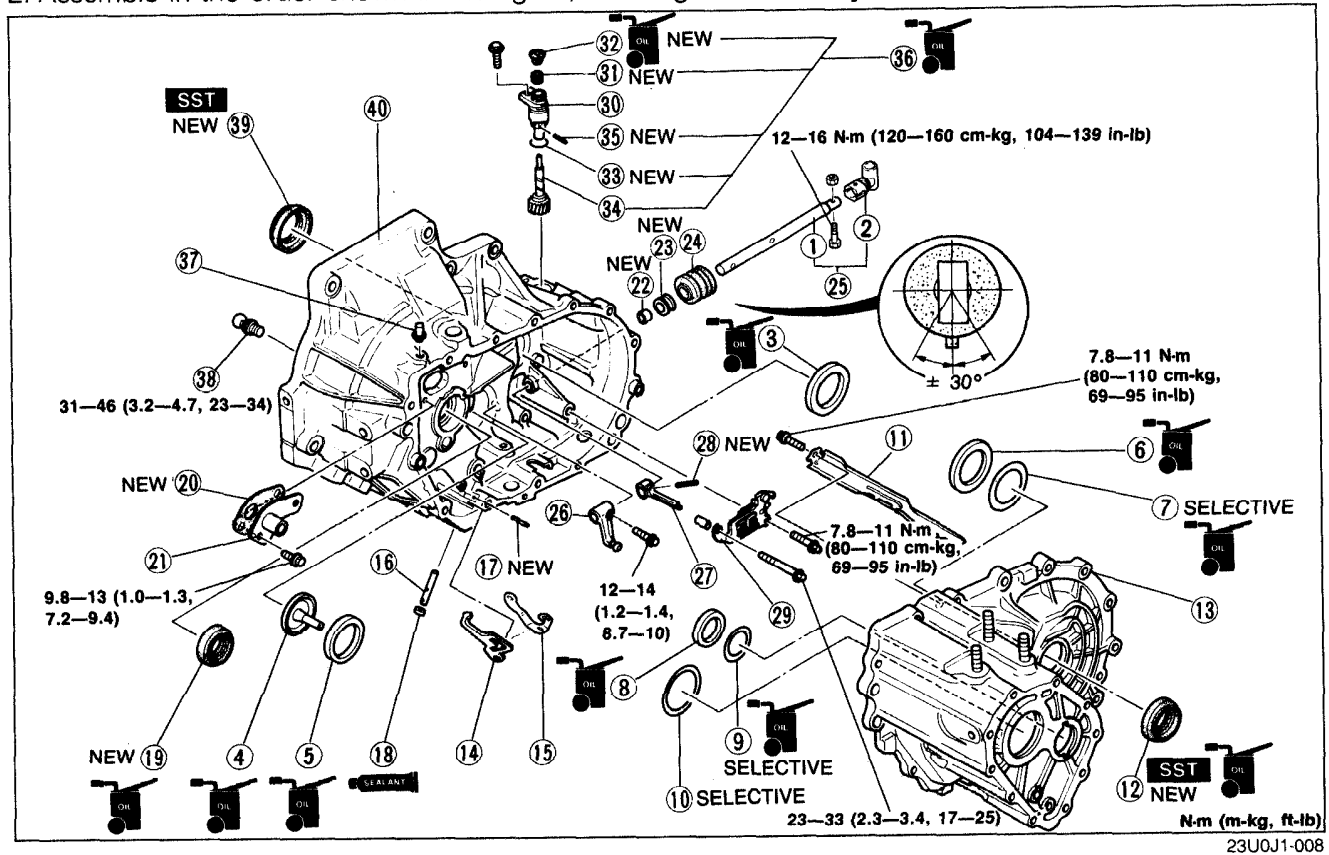

23U0J1-008

- | | | |
|-------------------------------|-----------------------------------|-----------------------------|
| 1. Change rod | 11. Oil passage | 29. Guide plate assembly |
| 2. Joint | 12. Oil seal (Differential) | 30. Gear case |
| 3. Bearing outer race | Assembly Note | 31. Oil seal |
| 4. Funnel | page J1-41 | (Speedometer gear case) |
| Assembly Note | 13. Transaxle case | Assembly Note |
| page J1-42 | 14. Reverse lever | page J1-41 |
| 5. Bearing outer race | 15. Lever set spring | 32. Packing |
| Assembly Note | 16. Reverse lever shaft | 33. O-ring |
| page J1-42 | 17. Roll pin | 34. Drive gear |
| 6. Bearing outer race | 18. Blind plug | 35. Roll pin |
| (Differential) | 19. Oil seal (Primary shaft gear) | (Speedometer driven gear |
| Assembly Note | Assembly Note | assembly) |
| page J1-41 | page J1-42 | Assembly Note |
| 7. Adjust shim (Differential) | 20. Gasket | page J1-41 |
| Assembly Note | 21. Bleeder cover | 36. Speedometer driven gear |
| page J1-41 | 22. Bushing | assembly |
| 8. Bearing outer race | 23. Oil seal (Change rod) | 37. Bleeder |
| (Secondary shaft gear) | Assembly Note | 38. Pivot |
| Assembly Note | page J1-42 | 39. Oil seal (Differential) |
| page J1-41 | 24. Boot | Assembly Note |
| 9. Adjust shim | Assembly Note | page J1-41 |
| (Secondary shaft gear) | page J1-42 | 40. Clutch housing |
| Assembly Note | 25. Change rod | |
| page J1-41 | Assembly Note | |
| 10. Adjust shim | page J1-42 | |
| (Primary shaft gear) | 26. Change arm | |
| Assembly Note | 27. Selector | |
| page J1-42 | 28. Roll pin | |

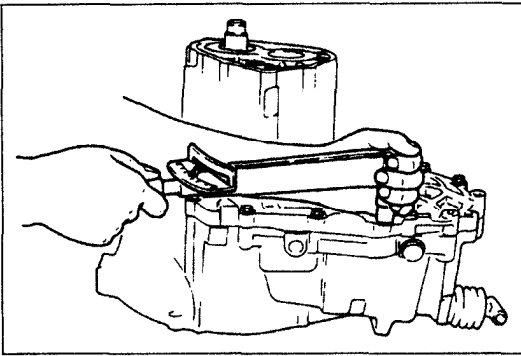

03U0J1-083

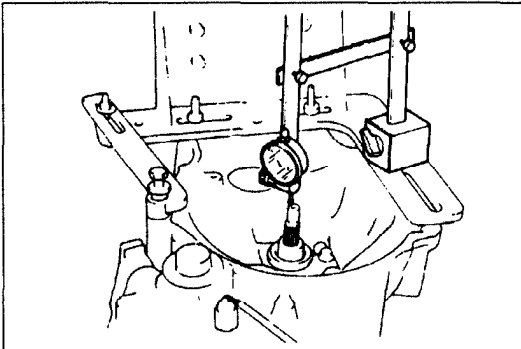

03U0J1-084

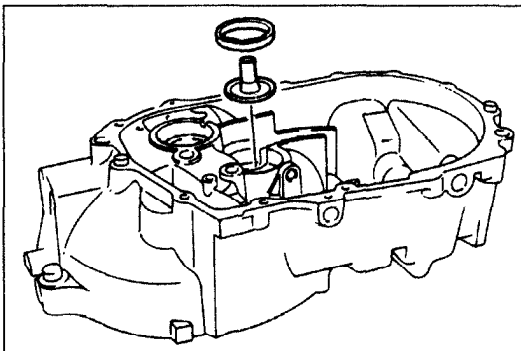

03U0J1-085

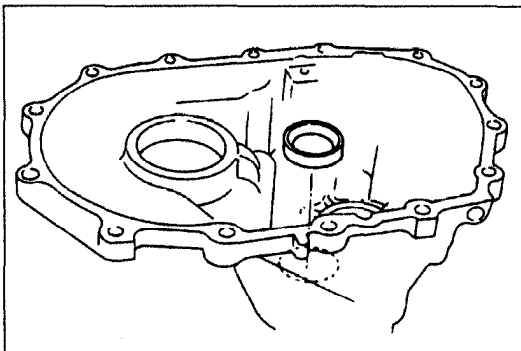

03U0J1-086

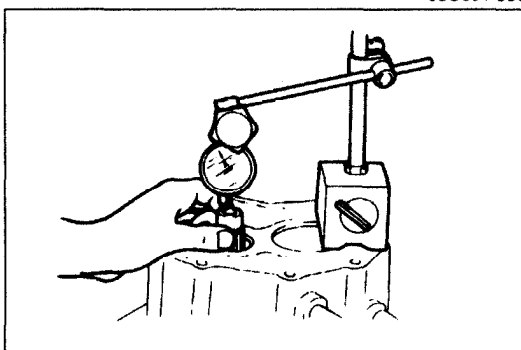

13U0J1-004

Shim selection

Adjust the bearing preload and select the shim(s) as follows.

Primary shaft assembly

1. Set the primary shaft assembly into the clutch housing.
2. Install the transaxle case to the clutch housing and tighten the bolts to the specified torque.

Tightening torque:

19—26 N·m (1.9—2.6 m·kg, 14—19 ft·lb)

3. Mount a dial indicator to the transaxle hanger and measure the primary shaft thrust clearance.

Clearance: 0.005—0.100mm (0.0002—0.0039 in)

4. Select the closest shim on the thin side from the table.

Adjustment shim thickness:

mm (in)

0.1 (0.004)	0.2 (0.008)	0.3 (0.012)	0.4 (0.016)
0.5 (0.020)	0.6 (0.024)		

Secondary shaft bearing preload

1. Install the funnel and bearing outer race into the clutch housing.
2. Set the secondary shaft into the clutch housing.

3. Install the secondary shaft bearing outer race into the transaxle case.
4. Install the transaxle case to the clutch housing and tighten the bolts to the specified torque.

Tightening torque:

19—26 N·m (1.9—2.6 m·kg, 14—19 ft·lb)

5. Mount a dial indicator to the transaxle case and measure the secondary shaft end play.
6. Select the shim as follows.
 - (a) Add 0.03mm (0.0012 in) to the thrust clearance.
 - (b) Add 0.08mm (0.0031 in) to the thrust clearance.
 - (c) Select the thickest shim in the range from (a) to (b) from the table.

Example: 0.22mm (0.009 in)
 0.22mm (0.009 in) + 0.03mm (0.001 in)
 = 0.25mm (0.010 in)
 0.22mm (0.009 in) + 0.08mm (0.003 in)
 = 0.30mm (0.012 in)
Range: 0.25mm (0.010 in)—0.30mm (0.012 in)
Select the 0.30mm (0.012 in).

Adjustment shim thickness:

mm (in)

0.15 (0.006)	0.20 (0.008)	0.25 (0.010)	0.30 (0.012)
0.35 (0.014)	0.40 (0.016)	0.45 (0.018)	0.50 (0.020)

93G0J1-524

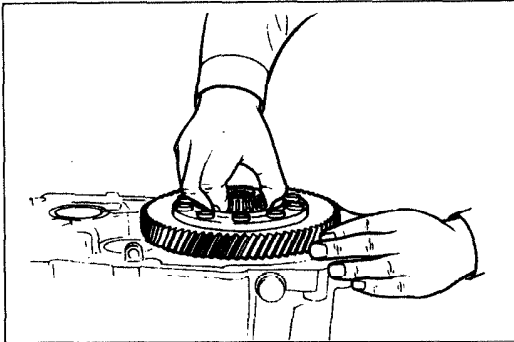

03U0J1-089

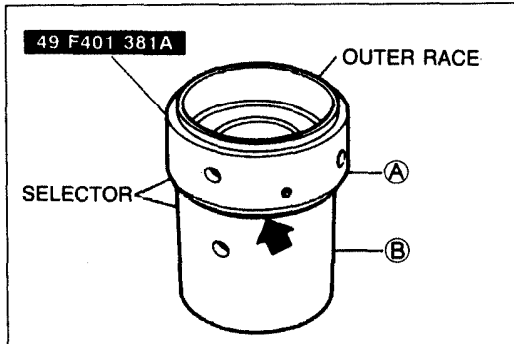

03U0J1-090

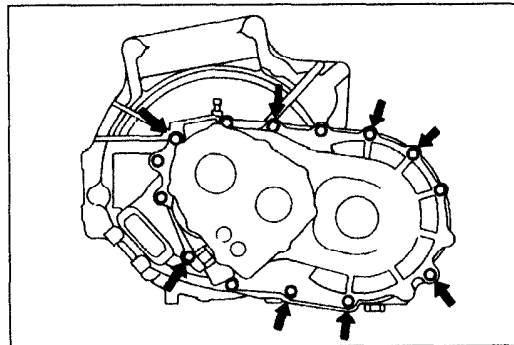

03U0J1-091

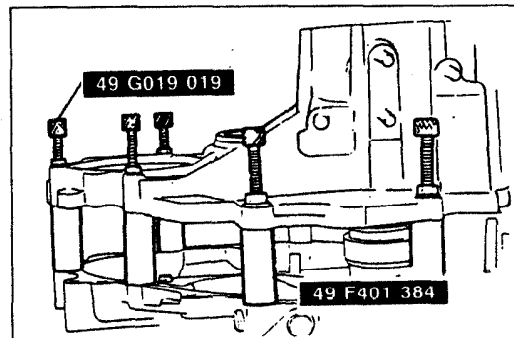

03U0J1-092

Differential

1. Install the bearing outer race into the clutch housing.
2. Set the differential assembly into the clutch housing.

Note

- Turn A and B until the gap shown in the figure is eliminated.

3. Install the transaxle case side bearing outer race to the **SST** (selector).

4. Set the **SST** (collars) in the positions shown in the figure.

5. Tighten the **SST** (bolts) to the specified torque.

Tightening torque:

19—26 N·m (1.9—2.6 m·kg, 14—19 ft·lb)

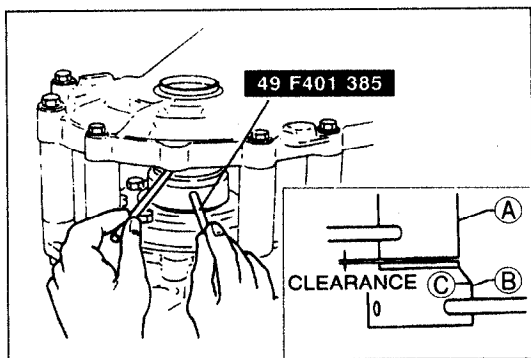

03U0J1-093

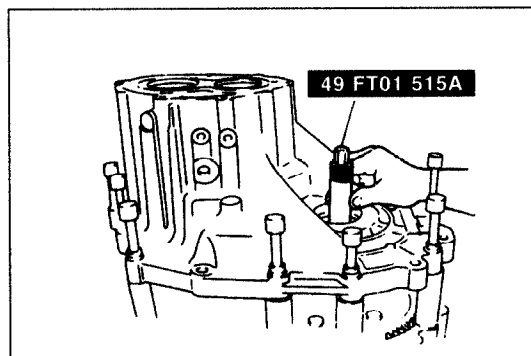

03U0J1-094

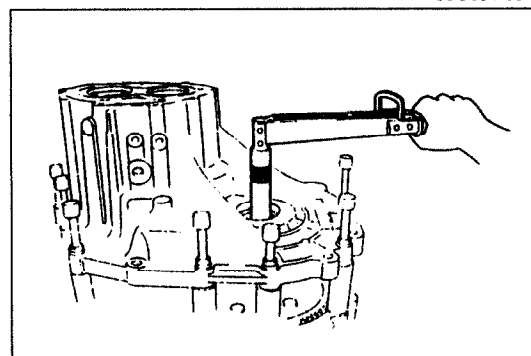

03U0J1-095

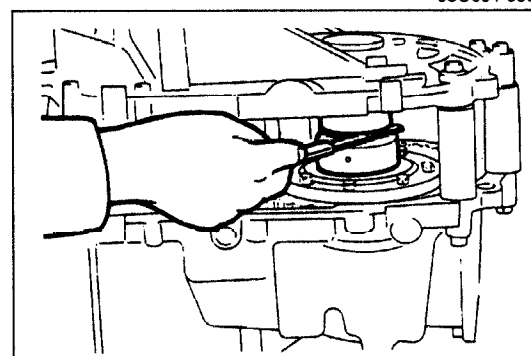

03U0J1-096

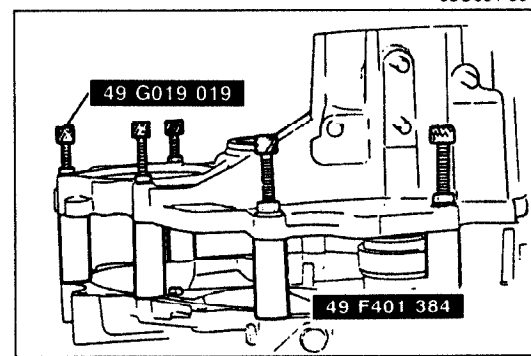

03U0J1-097

Note

- Turn the bars until the **SST (selector)** can no longer be moved.

- To seat the bearings, mount the bars on parts (A) and (B) of the selector, and turn the selector so the gap is widened.
- Turn in the reverse direction until the gap is eliminated.

- Install the **SST** to the differential pinion gear through the transaxle case.

- Turn the **SST** with a torque wrench. Adjust the **SST (selector)** with the bars until the specified preload is obtained.

Preload:

0.03—0.74 N·m (0.3—7.6 cm·kg, 0.26—6.60 in·lb)

- Remove the **SST**.

- Measure the clearance around the entire circumference of the **SST (selector)**.
- Select the proper adjust shim(s) to be used for the differential by referring to the table and selecting the shim which is nearest (on the thick side) to the largest measured clearance in the selector.

Adjust shim thickness:

mm (in)

0.20 (0.008)	0.25 (0.010)	0.30 (0.012)	0.35 (0.014)
0.40 (0.016)	0.45 (0.018)	0.50 (0.020)	0.55 (0.022)

- Remove the **SST (bolts)**.
- Remove the transaxle case and the **SST (collars)**.

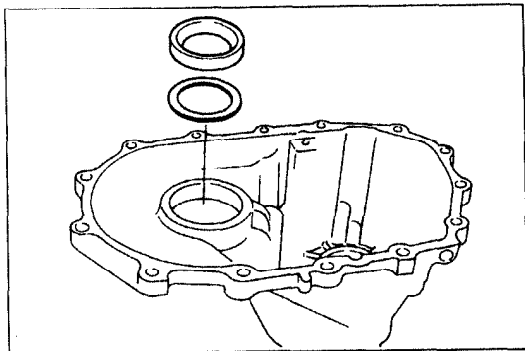

03U0J1-098

15. Remove the bearing outer race from the **SST** (selector).
16. Install the selected shim(s) and bearing outer race to the transaxle case.

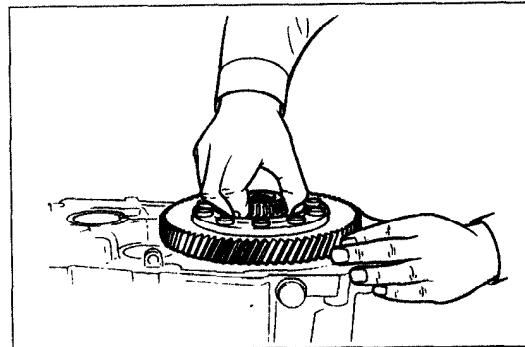

03U0J1-099

Bearing preload (Differential)

Measure the preload as follows.

1. Set the differential assembly into the clutch housing.

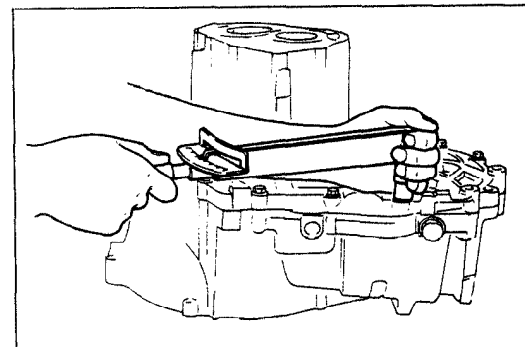

03U0J1-100

2. Install the transaxle case onto the clutch housing.

Tightening torque:

19—26 N·m (1.9—2.6 m·kg, 14—19 ft·lb)

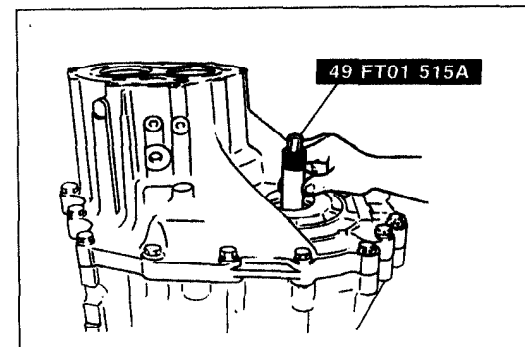

03U0J1-101

3. Install the **SST** to the differential side gear through the transaxle case.

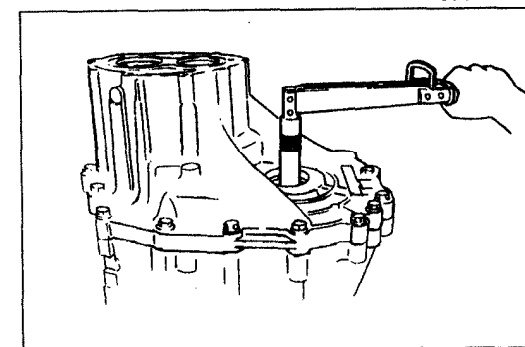

03U0J1-102

4. Measure the bearing preload.

Preload:

0.03—0.74 N·m (0.3—7.6 cm·kg, 0.26—6.60 in·lb)

5. If not as specified, readjust the bearing preload.
6. Remove the **SST**.
7. Remove the transaxle case and differential assembly.

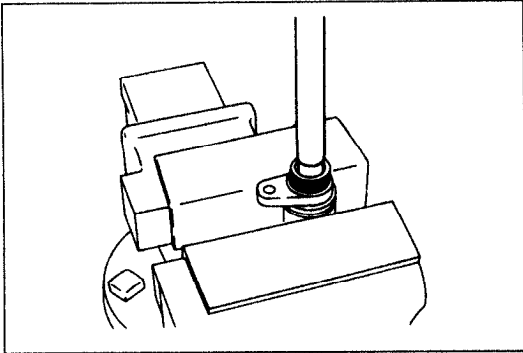

23U0J1-009

Assembly note

Oil seal (Speedometer gear case)

1. Install the new oil seal with a suitable pipe.

Pipe diameter: 15mm (0.591 in)

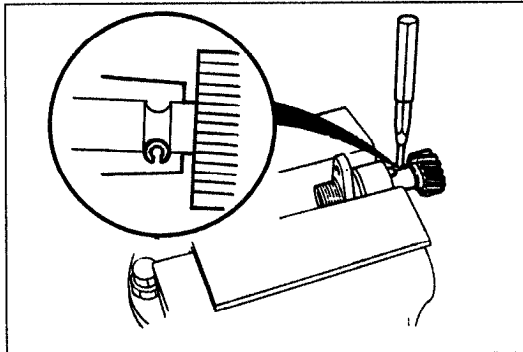

03U0J1-104

Roll pin (Speedometer driven gear assembly)

1. Install the new roll pin as shown in the figure.

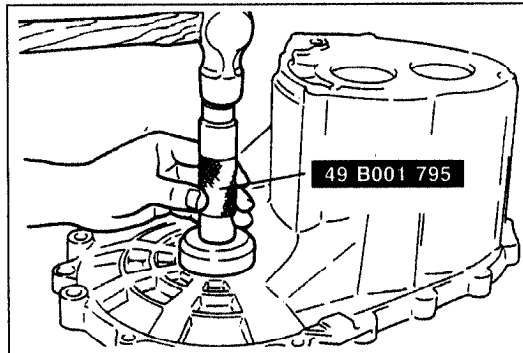

03U0J1-105

Oil seal (Differential)

Caution

- Apply transaxle oil to the outer circumference of the oil seal.

1. Install the new oil seal with the SST.

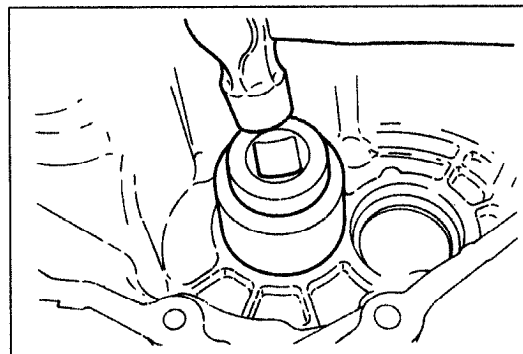

03U0J1-106

Adjust shim and bearing outer race (Secondary shaft gear)

Caution

- Use adjust shim(s) selected during bearing preload adjustment.
- Apply transaxle oil to the bearing outer race.

1. Install the adjust shim(s) and the bearing outer race with a suitable pipe.

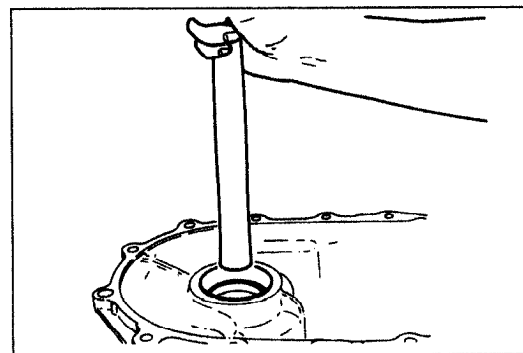

03U0J1-107

Adjust shim and bearing outer race (Differential)

Caution

- Use adjust shim(s) selected during bearing preload adjustment.
- Apply transaxle oil to the bearing outer race.

1. Install the adjust shim(s) and the bearing outer race with a suitable pipe.

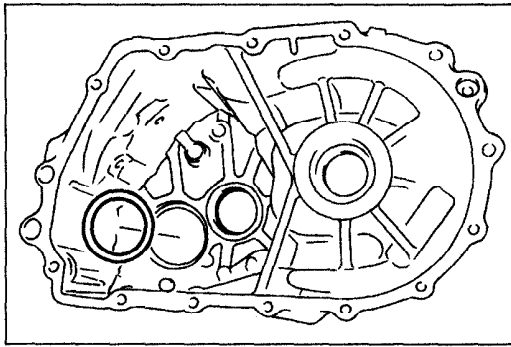

03U0J1-108

Adjust shim (Primary shaft gear)

Caution

- Use adjust shim(s) selected during bearing preload adjustment.

1. Apply transaxle oil to the adjust shim(s) and install it.

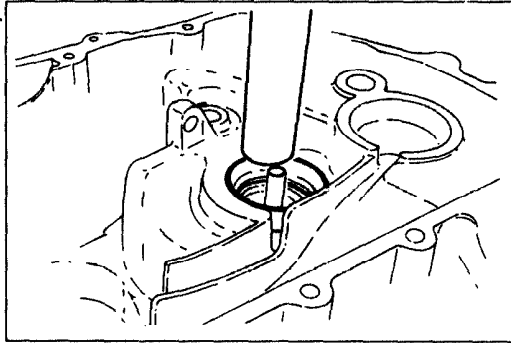

23U0J1-010

Funnel and bearing outer race

Caution

- Apply transaxle oil to the bearing outer race.

1. Install the funnel and the bearing outer race.

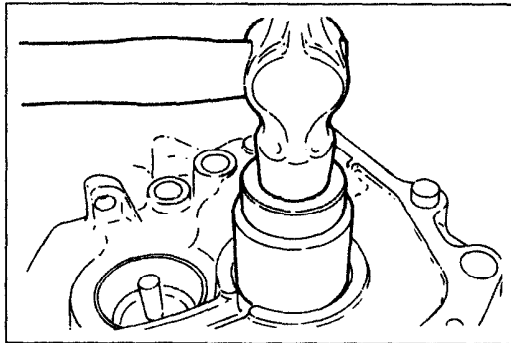

03U0J1-110

Oil seal (Primary shaft gear)

Caution

- Apply transaxle oil to outer circumference of the oil seal.

1. Install the new oil seal with a suitable pipe.

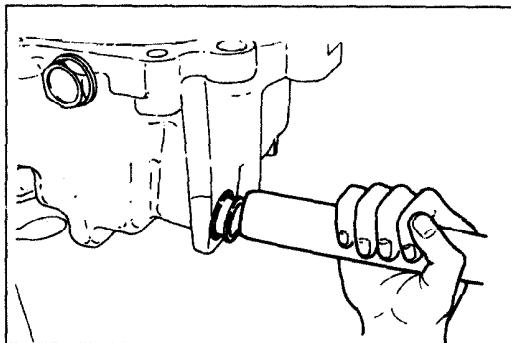

03U0J1-111

Oil seal (Change rod)

Caution

- Apply transaxle oil to the oil seal lip.

1. Install the oil seal.

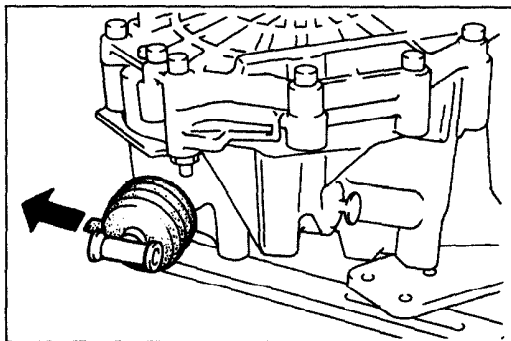

03U0J1-112

Boot and change rod assembly

Caution

- Install the boot with the air bleed downward as shown in the figure.

1. Slide the boot onto the change rod assembly.
2. Install the change rod assembly into the clutch housing.

MEMO

1. Control rod	22. 5th shift rod
2. Control end	Assembly Note..... page J1-46
3. 1st/2nd shift fork	23. Reverse idler gear
4. Control lever	Assembly Note..... page J1-46
5. Interlock sleeve	24. Reverse idler shaft
6. 3rd/4th shift fork	Assembly Note..... page J1-46
7. Clutch hub	25. Magnet
8. Synchronizer key	26. Transaxle case assembly
9. Clutch hub sleeve	Assembly Note..... page J1-47
10. Synchronizer spring	27. Neutral switch
11. Clutch housing	28. Back-up light switch
12. Differential assembly	29. Lock bolt and washer
13. Secondary shaft gear assembly	30. Secondary 5th gear
Assembly Note..... page J1-45	31. Gear sleeve
14. Primary shaft gear assembly	32. 5th gear
Assembly Note..... page J1-45	33. Synchronizer ring (5th)
15. Spring	34. Clutch hub assembly (5th)
16. Steel ball	Assembly Note..... page J1-47
17. Shift fork and shift rod assembly	35. 5th shift fork
Assembly Note..... page J1-45	Assembly Note..... page J1-47
18. Crank lever assembly	36. Stop plate
Assembly Note..... page J1-46	37. Locknut (Secondary shaft)
19. Crank lever shaft	Assembly Note..... page J1-47
Assembly Note..... page J1-46	38. Locknut (Primary shaft)
20. Pin	Assembly Note..... page J1-47
21. 5th shift rod end	39. Rear cover
Assembly Note..... page J1-46	

13U0J1-005

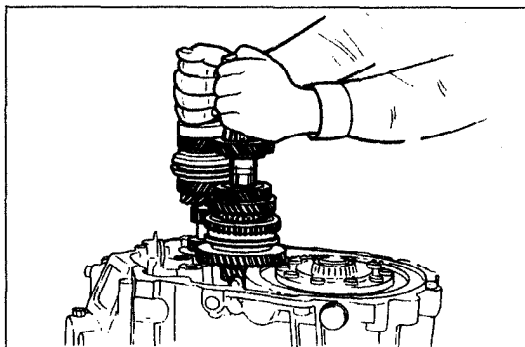

03U0J1-115

Assembly note
Primary shaft gear assembly and secondary shaft gear assembly

1. Install the primary shaft gear assembly and the secondary shaft gear assembly together.

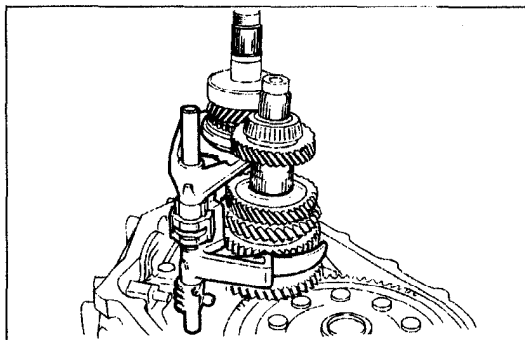

03U0J2-088

Shift fork and shift rod assembly

1. Shift to 2nd gear and position the shift fork and shift rod assembly as shown.

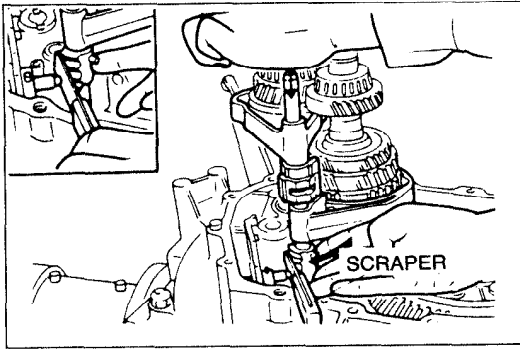

03U0J2-089

2. Insert the spring seat and spring into the reverse lever shaft, install the steel ball, and place a scraper so that it contacts the steel ball.
3. With the edge of the control end against the scraper, when the control end is pushed in the direction of the arrow in the figure so that the ball goes into the shaft, the rod will at the same time line up with the shift rod coupling hole in the clutch housing.

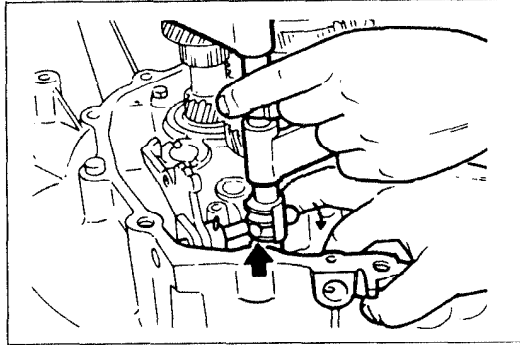

03U0J2-090

4. Set each clutch hub sleeve to the neutral position, and tap the shift rod from above so that the steel ball goes into the center groove (of the 3 grooves in the control end).
5. Pull the ball part of the control end forward so that the steel ball goes into the detent in the groove.

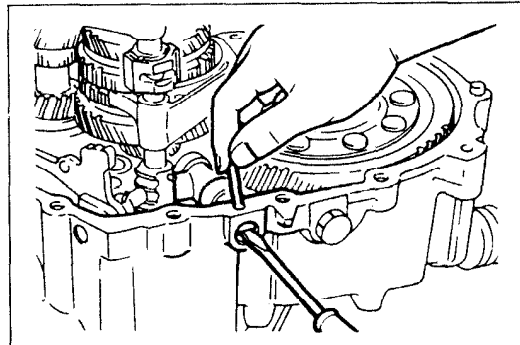

03U0J2-091

Crank lever assembly and crank lever shaft

Note

- Use a new O-ring for the crank lever shaft.

1. Fit the crank lever between the change arm and the control end, and connect the crank lever shaft to the crank lever.
2. Align the pin holes of the crank lever shaft and the clutch housing, and insert the new pin.

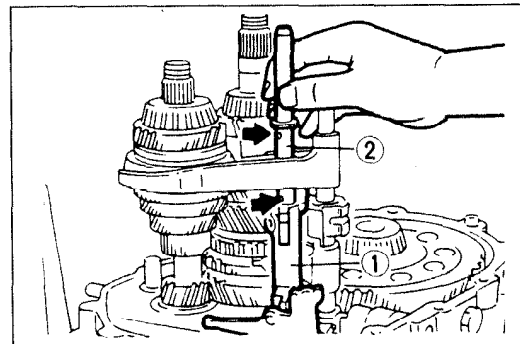

03U0J1-116

5th shift rod end and 5th shift rod

Note

- The mark (indicated by the arrow in the figure) and the shift rod end mounting bolt hole must be in the same direction.

1. Install the shift rod end (1) and the shift rod (2), and tighten the gate mounting bolt.

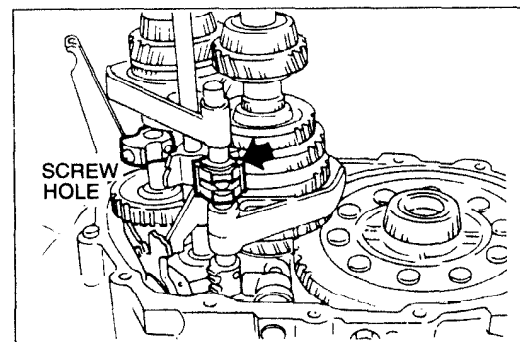

03U0J2-093

Reverse idler gear and reverse idler shaft

1. Install the reverse idler gear and the reverse idler shaft.
2. Attach the magnet to the clutch housing.
3. Align the end of the interlock sleeve with the control lever (indicated by the arrow), and, at the same time, face the reverse idler shaft screw hole in the direction shown in the figure.

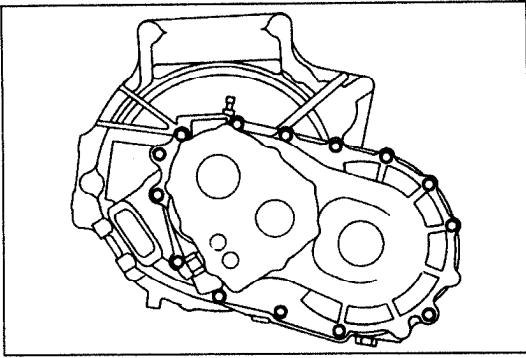

23U0J1-011

Transaxle case assembly

1. Apply a thin coat of sealant to the contact surfaces of the clutch housing and transaxle case, tighten the transaxle case installation bolts to the specified torque.

Tightening torque:

19—26 N·m (1.9—2.6 m·kg, 14—19 ft·lb)

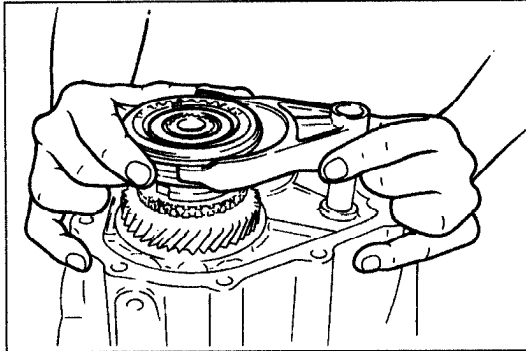

03U0J1-117

Clutch hub assembly (5th) and 5th shift fork

1. Install the clutch hub assembly (5th) and the 5th shift fork together.

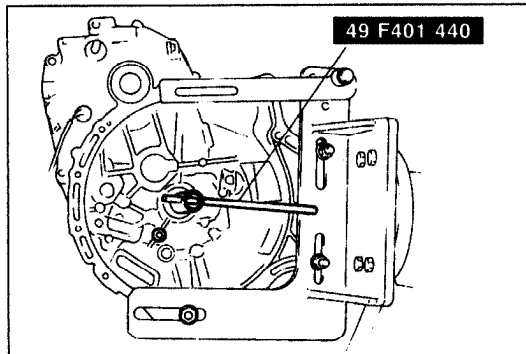

03U0J1-145

Locknut

1. Shift to 1st gear.
2. Lock the primary shaft with the **SST**.
3. Tighten new locknuts on the primary and secondary shafts.

Tightening torque:

128—206 N·m (13.0—21 m·kg, 94—152 ft·lb)

4. Stake the locknuts.

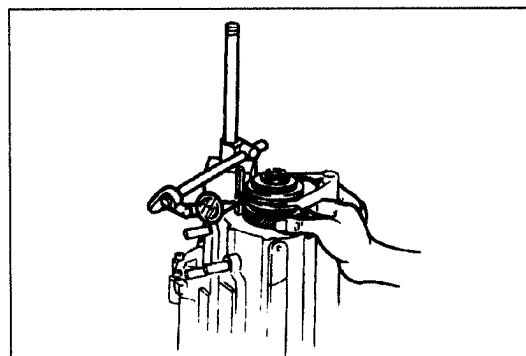

03U0J1-118

5. Measure the 5th gear thrust clearance with a dial indicator.

Clearance: 0.06—0.26mm (0.0024—0.0102 in)

Maximum: 0.31mm (0.0122 in)

6. If not as specified, reassemble the transaxle.

INSTALLATION

1. Raise the vehicle and support it with safety stands.
2. Install in the order shown in the figure, referring to **Installation Note**.
3. Add the specified amount of the specified transaxle oil. (Refer to page J1-7.)
4. Warm up the engine and transaxle, and inspect for oil leakage and transaxle operation.

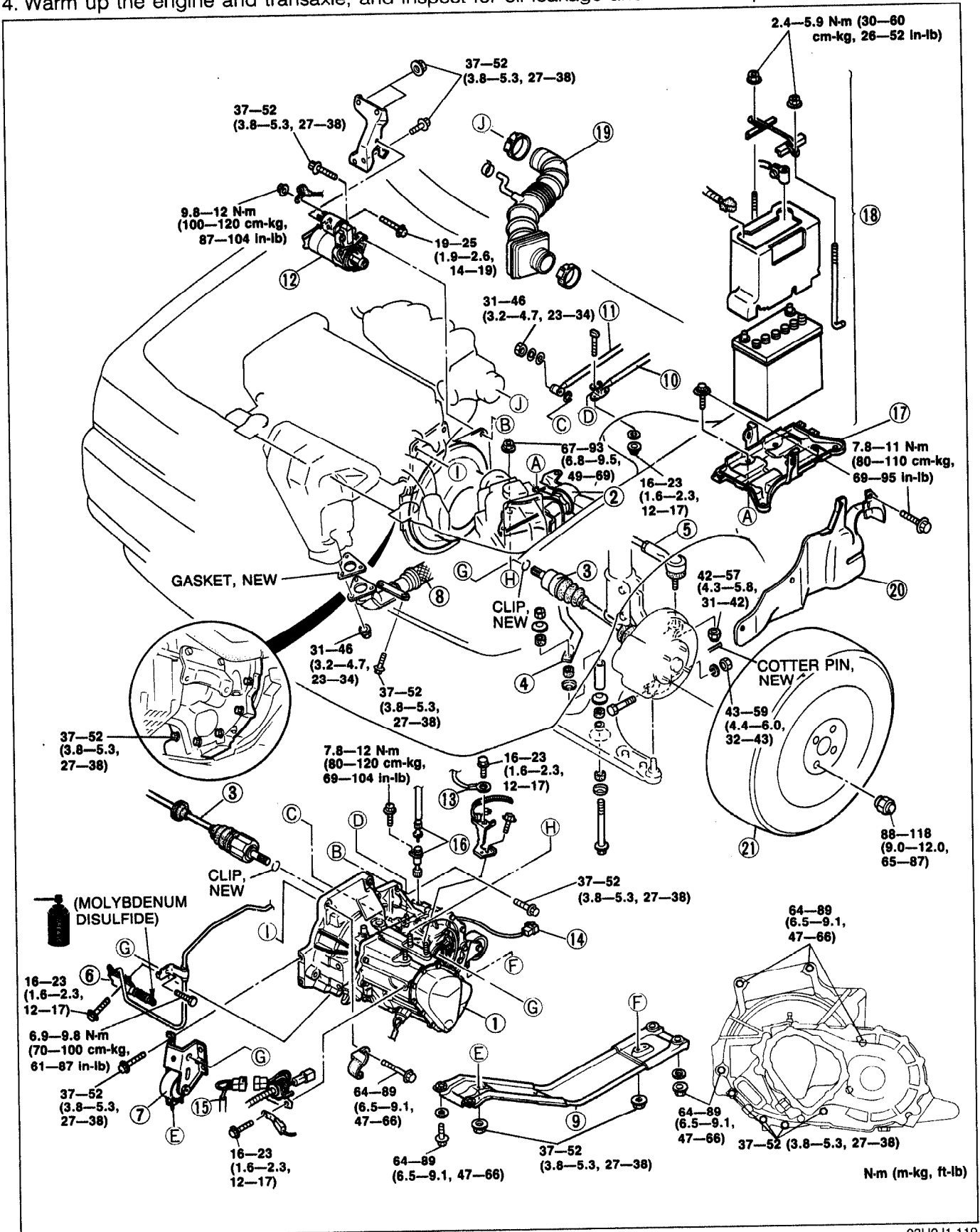

1. Transaxle Installation Note page J1-49	11. Extension bar Installation Note page J1-51
2. Engine mount No.4	12. Starter
3. Driveshaft Installation Note page J1-50	13. Ground Installation Note page J1-51
4. Stabilizer (BP SOHC) Installation Note page J1-50	14. Neutral switch connector
5. Tie-rod end Installation Note page J1-50	15. Back-up light switch connector
6. Clutch release cylinder	16. Speedometer cable Installation Note page J1-51
7. Engine mount No.2	17. Battery carrier
8. Exhaust pipe	18. Battery
9. Engine mounting member Installation Note page J1-50	19. Air hose and resonance chamber
10. Control rod Installation Note page J1-51	20. Splash shield
	21. Wheel and tire

03U0J1-120

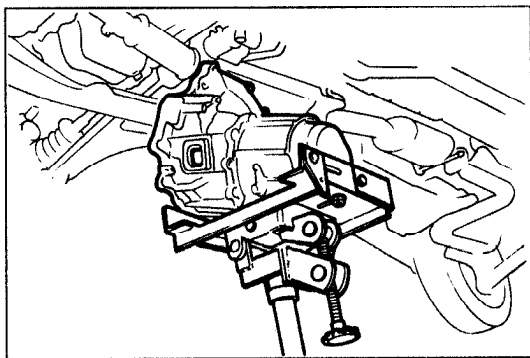

03U0J1-121

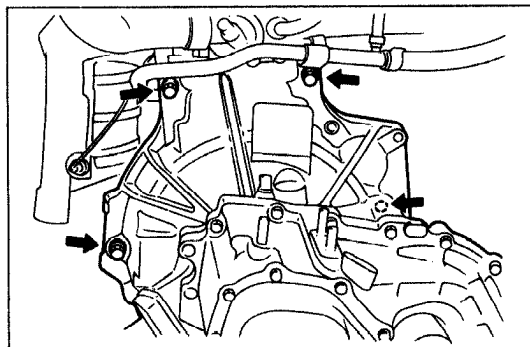

03U0J1-122

**Installation Note
Transaxle**

1. Set the transaxle on a jack and lift it into place.

2. Install the transaxle bolts.

Tightening torque:
64—89 N·m (6.5—9.1 m·kg, 47—66 ft·lb)

3. Loosely tighten engine mount No.4 bolts.

Driveshaft

Caution

- Verify that the oil seal is not damaged.
- Do not damage the oil seal

1. Insert the clip with the end-gap at the top of the groove.
2. Apply transaxle oil around the oil seal lip. Install the driveshaft.
3. Verify that the driveshaft is correctly seated by pulling on the shaft.
4. Connect the lower arm to the knuckle and tighten the clinch bolt.

Tightening torque:

43—59 N·m (4.4—6.0 m·kg, 32—43 ft·lb)

Stabilizer (BP SOHC)

1. Tighten the nut until the specified amount of thread is exposed at the end of the bolt.

Dimension A: 17—19mm (0.67—0.75 in)

Tie-rod end

1. Install the locknut.

Tightening torque:

42—57 N·m (4.3—5.8 m·kg, 31—42 ft·lb)

2. Secure the locknut with a new cotter pin.

Engine mounting member

1. Install the bolts and nuts as shown.

Tightening torque

(A) : 37—52 N·m (3.8—5.3 m·kg, 27—38 ft·lb)

(B) : 64—89 N·m (6.5—9.1 m·kg, 47—66 ft·lb)

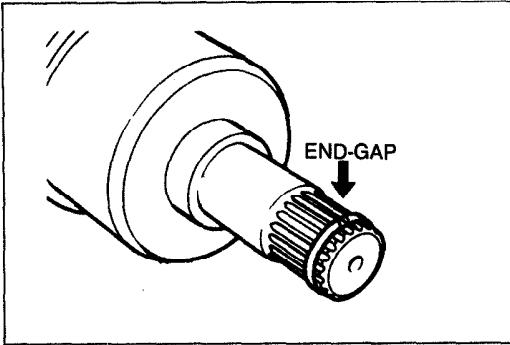

03U0J1-123

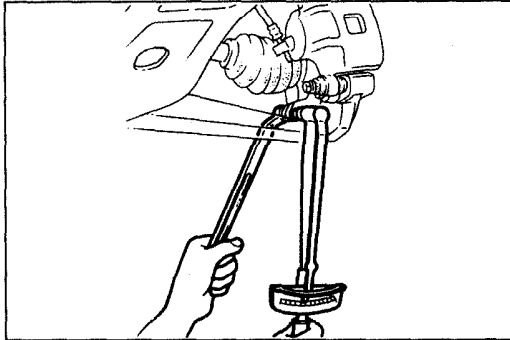

03U0J1-124

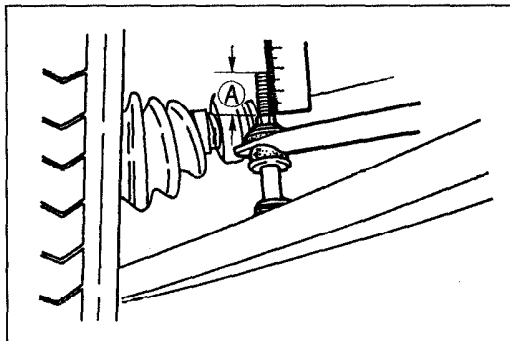

03U0J1-125

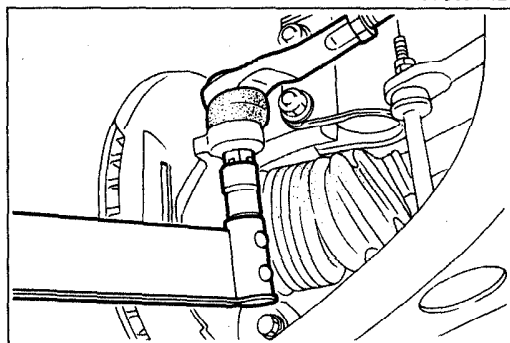

03U0J1-126

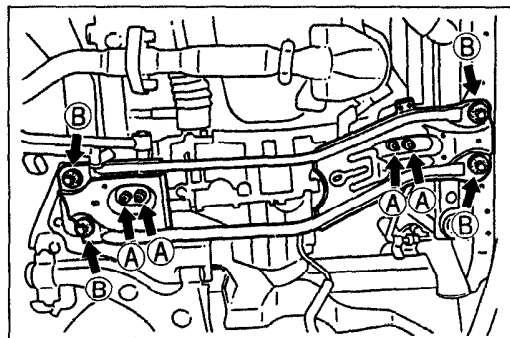

03U0J1-127

TRANSAXLE

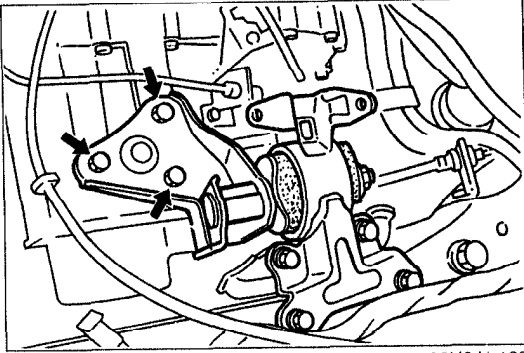

03U0J1-128

2. Tighten engine mount No.4 nuts.

Tightening torque:

67—93 N·m (6.8—9.5 m·kg, 49—69 ft·lb)

3. Remove the **SST** (Engine support).

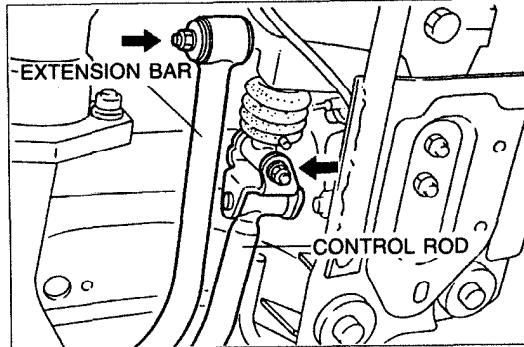

03U0J1-129

Control rod and extension bar

1. Install the extension bar to the transaxle.

Tightening torque:

31—46 N·m (3.2—4.7 m·kg, 23—34 ft·lb)

2. Install the change control rod to the transaxle.

Tightening torque:

16—23 N·m (1.6—2.3 m·kg, 12—17 ft·lb)

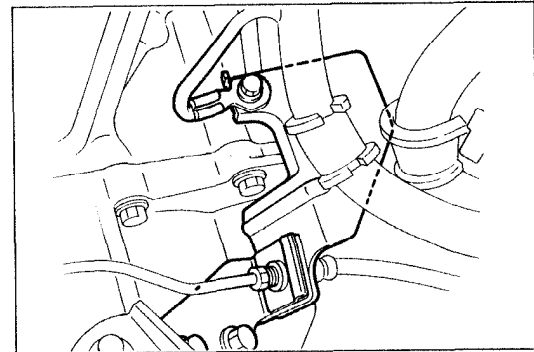

03U0J1-130

Ground

1. Connect the ground to the clutch pipe bracket.

Tightening torque:

16—23 N·m (1.6—2.3 m·kg, 12—17 ft·lb)

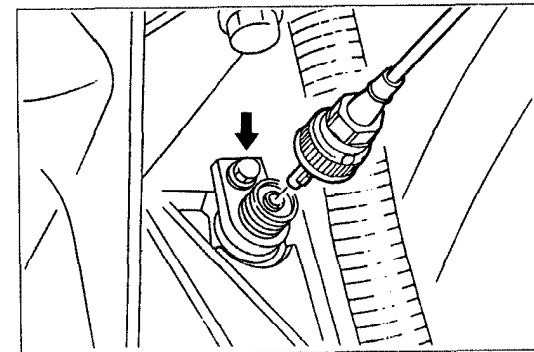

03U0J1-131

Speedometer cable

1. Add the specified oil through the speedometer gear case mounting. (Refer to page J1-7.)
2. Install the speedometer driven gear.



Tightening torque:

7.8—12 N·m (80—120 cm·kg, 69—104 in·lb)

3. Connect the speedometer cable to the speedometer driven gear.

DIFFERENTIAL

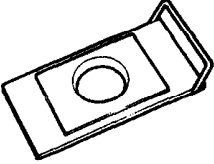
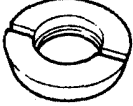
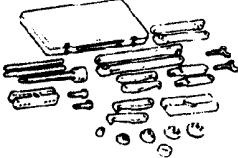
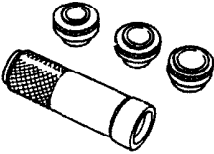
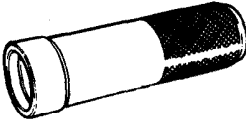
PREPARATION SST

<p>49 B017 1A0</p> <p>Remover set, bearing</p> 	<p>For removal of bearing</p>	<p>49 F401 366A</p> <p>Plate (Part of 49 B017 1A0)</p> 	<p>For removal of bearing</p>
<p>49 B092 371</p> <p>Attachment E (Part of 49 B017 1A0)</p> 	<p>For removal of bearing</p>	<p>49 0839 425C</p> <p>Puller set, bearing</p> 	<p>For removal of bearing</p>
<p>49 F401 330B</p> <p>Installer set, bearing</p> 	<p>For installation of bearing</p>	<p>49 F401 331</p> <p>Body (Part of 49 F401 330B)</p> 	<p>For installation of bearing</p>
<p>49 F401 337A</p> <p>Attachment C (Part of 49 F401 330B)</p> 	<p>For installation of bearing</p>	<p>03U0J1-132</p>	

DISASSEMBLY / INSPECTION / ASSEMBLY

Caution

- Do not remove the inner race if not necessary.

1. Before disassembly, inspect the backlash of side gear and pinion gear, referring to **Preinspection**.
2. Disassemble in the order shown in the figure, referring to **Disassembly Note**.
3. Inspect all parts and repair or replace as necessary.
4. Assemble in the reverse order of disassembly, referring to **Assembly Note**.
5. Measure the backlash after assembly, referring to **Backlash of Side Gear and Pinion Gear**.

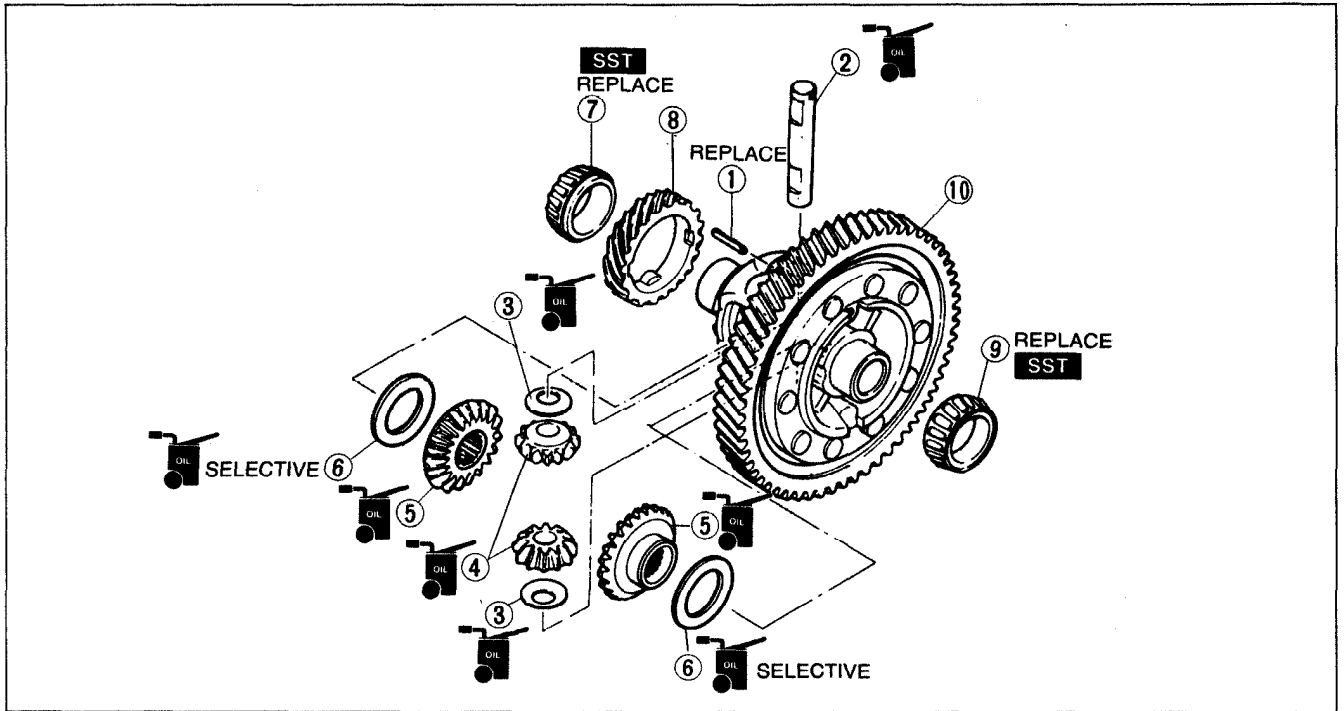

13U0J1-007

- | | |
|--|---|
| <ol style="list-style-type: none"> 1. Roll pin
Assembly Note..... page J1-55 2. Pinion shaft 3. Thrust washer 4. Pinion gear
Inspect for wear and cracks
Preinspection page J1-53
Inspection of backlash..... page J1-55 5. Side gear
Inspect for wear and cracks
Preinspection page J1-53
Inspection of backlash..... page J1-55 6. Thrust washer | <ol style="list-style-type: none"> 7. Side bearing inner race
Disassembly Note page J1-54
Inspection..... page J1-54
Assembly Note..... page J1-55 8. Speedometer drive gear
Assembly Note..... page J1-55 9. Side bearing inner race
Disassembly Note page J1-54
Inspection..... page J1-54
Assembly Note..... page J1-55 10. Ring gear and ring case
Inspection..... page J1-54 |
|--|---|

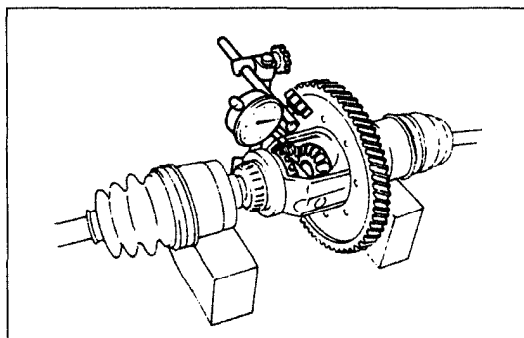

03U0J1-134

Preinspection

Backlash of side gear and pinion gear

Measure the backlash by the following procedure.

1. Install the left and right driveshafts in the differential assembly.
2. Support the driveshafts on V-blocks as shown in the figure.
3. Measure the backlash of both pinion gears.

Backlash: 0—0.1mm (0—0.004 in)

- If the backlash exceeds specification, adjust by selecting and installing thrust washers between the case and the side gears.

Caution

- Use thrust washers with the same thickness on each side.

Thrust washer thickness:

mm (in)

2.0 (0.079)	2.1 (0.083)	2.2 (0.087)
-------------	-------------	-------------

23U0J1-012

Disassembly Note

Side bearing inner race (Side opposite ring gear)

Caution

- Hold the gear case with one hand so that it does not fall.

- Remove the bearing inner race with the **SST**.

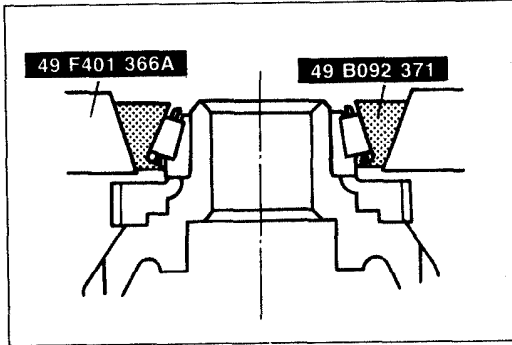

03U0J2-103

Side bearing inner race (Ring gear side)

Note

- Use pads in the vise.

- Remove the bearing inner race with the **SST**.

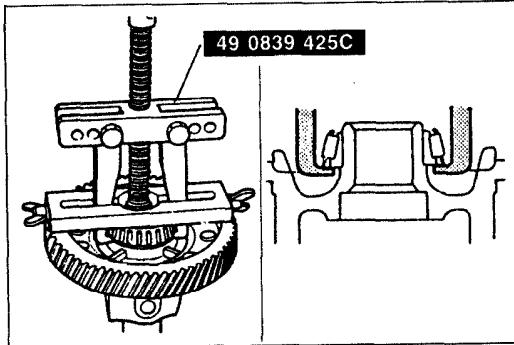

03U0J2-104

Inspection

Inspect all parts and repair or replace as necessary.

Ring gear and ring case

Note

- If the gear case is replaced, adjust the bearing preload.

- Inspect the ring gear for wear and cracks.

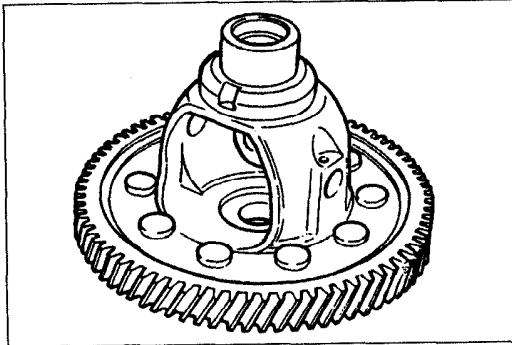

03U0J1-136

Bearing inner race

Note

- When replacing the bearing inner race, replace the bearing outer race and inner race as a set.
- If the bearing is replaced, adjust the bearing preload.

- Inspect for wear and rough rotation.

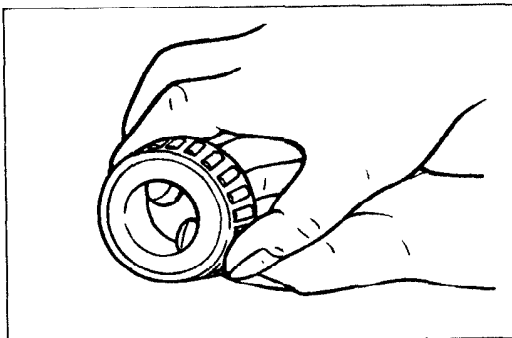

03U0J1-137

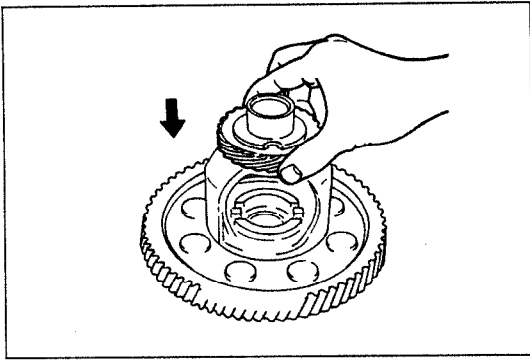

03U0J1-138

Assembly Note Speedometer drive gear

1. Install the speedometer drive gear as shown in the figure.

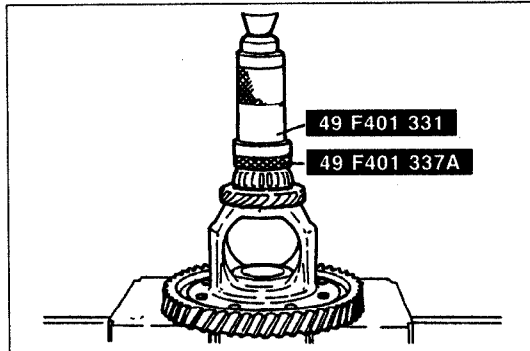

03U0J1-139

Side bearing inner race (Side opposite ring gear)

1. Install the speedometer drive gear.
2. Install the new side bearing inner race with the **SST**.

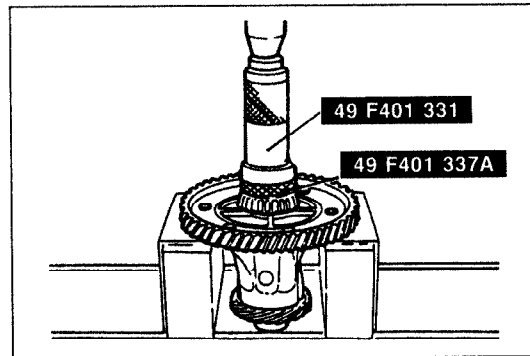

03U0J2-106

Side bearing Inner race (Ring gear side)

1. Install the new bearing inner race with the **SST**.

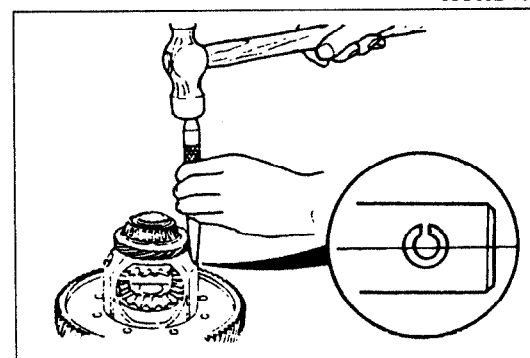

03U0J1-140

Roll pin

1. Install the new roll pin as shown in the figure to hold the pinion shaft.

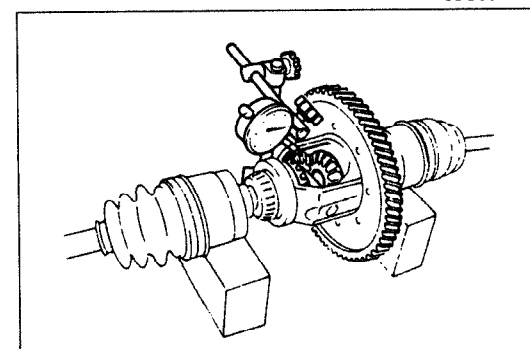

03U0J1-141

Backlash of Side Gear and Pinion Gear

Measure the backlash by the following procedure.

1. Install the driveshafts in the differential assembly.
2. Support the driveshafts on V-blocks as shown in the figure.
3. Measure the backlash of both pinion gears.

Backlash: 0—0.1mm (0—0.004 in)

4. If not as specified, select the proper thrust washers.
(Refer to preinspection, page J1-53.)

SHIFT MECHANISM

OVERHAUL

1. Disassemble in the order shown in the figure.
2. Inspect all parts and repair or replace as necessary.
3. Assemble in the reverse order of disassembly, referring to **Assembly Note**.

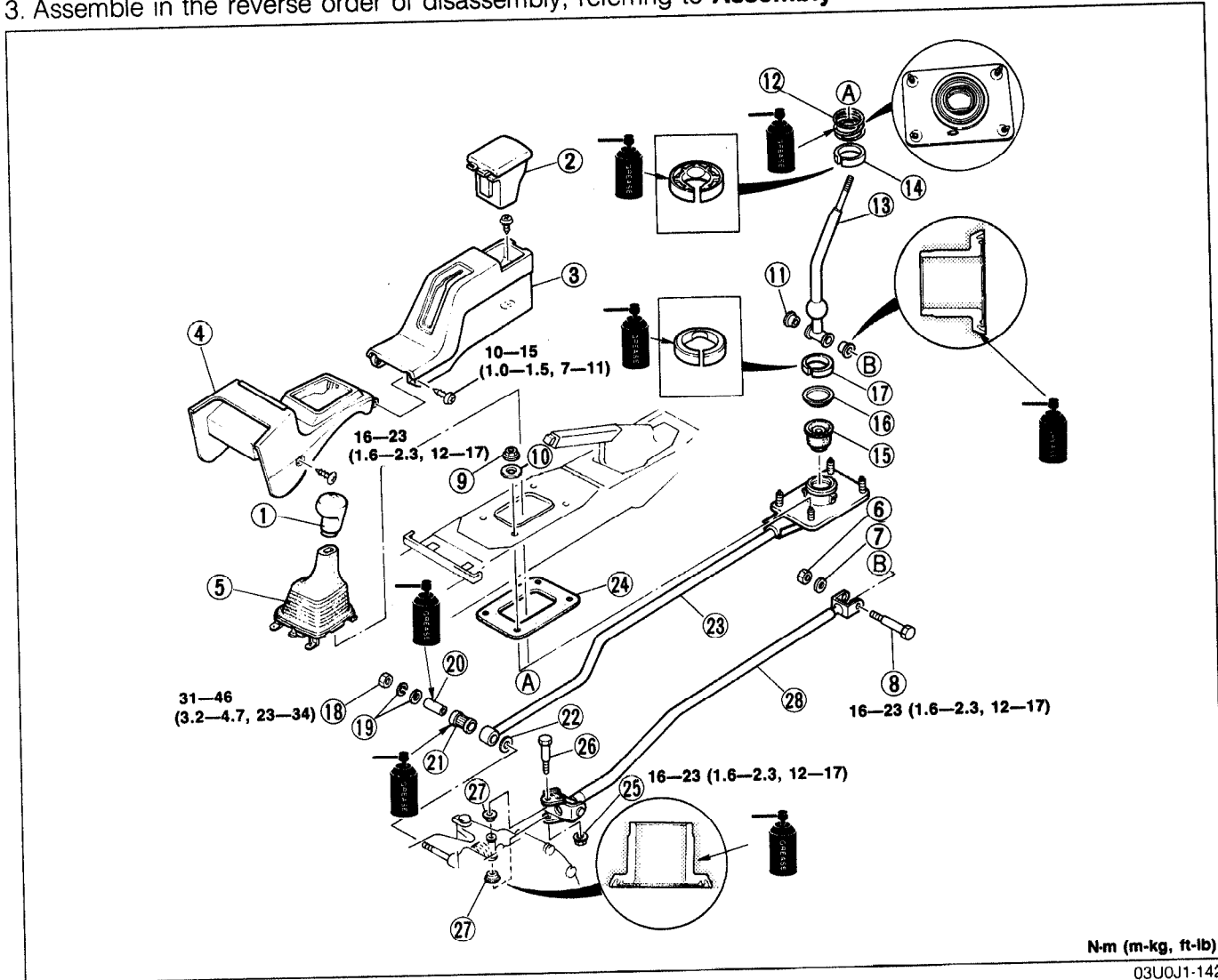

N-m (m-kg, ft-lb)

03U0J1-142

- | | |
|---|---|
| <ol style="list-style-type: none"> 1. Shift lever knob 2. Rear ashtray 3. Rear console 4. Front console 5. Boot 6. Nut 7. Washer 8. Bolt 9. Nut 10. Washer 11. Bushing 12. Spring
Inspect for damage and weakness
Assembly Note..... page J1-57 13. Shift lever 14. Ball seat (upper) 15. Boot
Inspect for wear and damage | <ol style="list-style-type: none"> 16. Holder 17. Ball seat (lower) 18. Nut 19. Washer 20. Pipe 21. Bushing
Inspect for wear and damage 22. Washer 23. Extension bar
Assembly Note..... page J1-57 24. Insulator
Inspect for damage and cracks 25. Nut 26. Bolt 27. Bushing
Inspect for wear and damage 28. Change control rod
Inspect for bending |
|---|---|

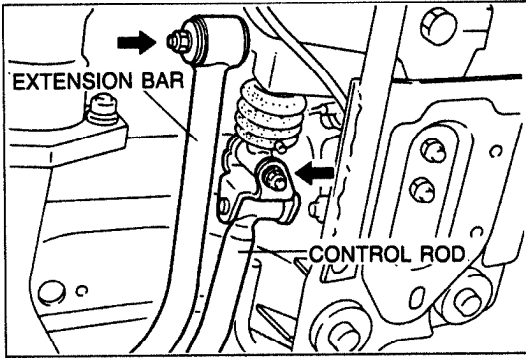

03U0J1-143

Assembly Note**Extension bar**

1. Connect the extension bar onto the transaxle, then mount it to the floor.

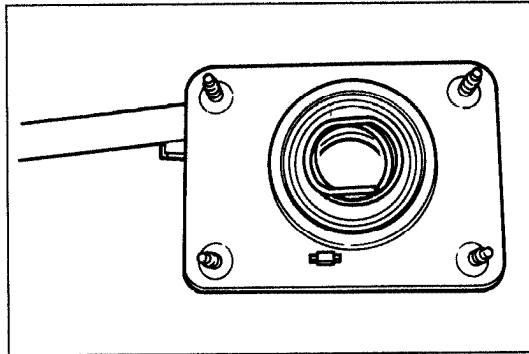
Tightening torque:**16—23 N·m (1.6—2.3 m·kg, 12—17 ft·lb)**

03U0J1-144

Spring

1. Verify that the hooked part of the spring is properly seated in the bracket groove.

