

Mazda6 (GH) Wiring Diagram

FOREWORD

This wiring diagram incorporates the wiring schematics of the Mazda 6 (GH) and available optional equipment. Actual vehicle wiring may vary slightly depending on optional equipment or local specifications, or both.

For proper repair and maintenance, a thorough familiarization with this manual is important, and it should always be kept in a handy place for quick and easy reference.

All the contents of this manual, including drawings and specifications, are the latest available at the time of printing.

As modifications affecting repair or maintenance occur, relevant information supplementary to this volume will be made available at Mazda dealers. This manual should be kept up-to-date.

Mazda Motor Corporation reserves the right to alter the specifications and contents of this manual without obligation or advance notice.

All rights reserved. No part of this book may be reproduced or used in any form or by any means, electronic or mechanical-including photocopying and recording and the use of any kind of information storage and retrieval system-without permission in writing.

Mazda Motor Corporation
HIROSHIMA, JAPAN

CONTENTS

TITLE	SECTION		
	PREVIOUS	NEW	
GENERAL INFORMATION	GI (GENERAL INFORMATION)	00	
	W (ELECTRICAL WIRING SCHEMATIC)		
	FB (FUSE BLOCK)		
	JB (JOINT BOX)		
	X (COMMON CONNECTOR)		
	Y (GROUND POINT)		
ENGINE	U (DATA LINK CONNECTOR)	01	
	A (CHARGING SYSTEM/ STARTING SYSTEM)		
	B (ENGINE CONTROL SYSTEM)		
SUSPENSION	Q (CRUISE CONTROL SYSTEM)	02	
DRIVELINE/AXLE	—	03	
BRAKES	—	04	
TRANSMISSION/ TRANSAXLE	O (ANTI-LOCK BRAKE SYSTEM)		
STEERING	H (EC-AT CONTROL SYSTEM)	05	
HEATER, VENTILATION & AIR CONDITIONING (HVAC)	N (ELECTRIC POWER STEERING SYSTEM)	06	
RESTRAINTS	G (AIR CONDITIONING SYSTEM)	07	
BODY & ACCESSORIES	S (SEAT BELT/AIR BAG SYSTEM)	08	
	C (GAUGE CONTROL SYSTEM)		
	D (WIPER SYSTEM)		
	E (EXTERIOR LIGHTING SYSTEM)		
	F (SIGNAL SYSTEM)		
	I (INTERIOR LIGHTING SYSTEM)		
	J (AUDIO SYSTEM)		09
	K (DOOR/WINDOW SYSTEM)		
	L (MIRROR SYSTEM)		
	M (SUNROOF SYSTEM)		
	P (POWER SEAT SYSTEM)		
	T (SECURITY AND LOCKS SYSTEM/OPTION)		
	ALPHABETICAL INDEX		AI (ALPHABETICAL INDEX)

©

Mazda Motor Corporation

APPLICATION:

This manual is applicable to vehicles beginning with the Vehicle Identification Numbers (VIN) shown on the following page.

**VEHICLE IDENTIFICATION NUMBERS (VIN)
(CHASSIS NUMBERS)**

JMZ GH1282*# 100001—
JMZ GH12D6*# 100001—
JMZ GH12F6*# 100001—
JMZ GH12F7*# 100001—
JMZ GH12L6*# 100001—
JMZ GH12L7*# 100001—
JMZ GH1482*# 100001—
JMZ GH14D6*# 100001—
JMZ GH14F6*# 100001—
JMZ GH14F7*# 100001—
JMZ GH14L6*# 100001—
JMZ GH14L7*# 100001—
JMZ GH19820# 100001—
JMZ GH19D60# 100001—
JMZ GH19F60# 100001—
JMZ GH19F70# 100001—
JMZ GH19L60# 100001—

ELECTRICAL WIRING SCHEMATIC (WITHOUT ADVANCED KEYLESS SYSTEM)

00E-1a

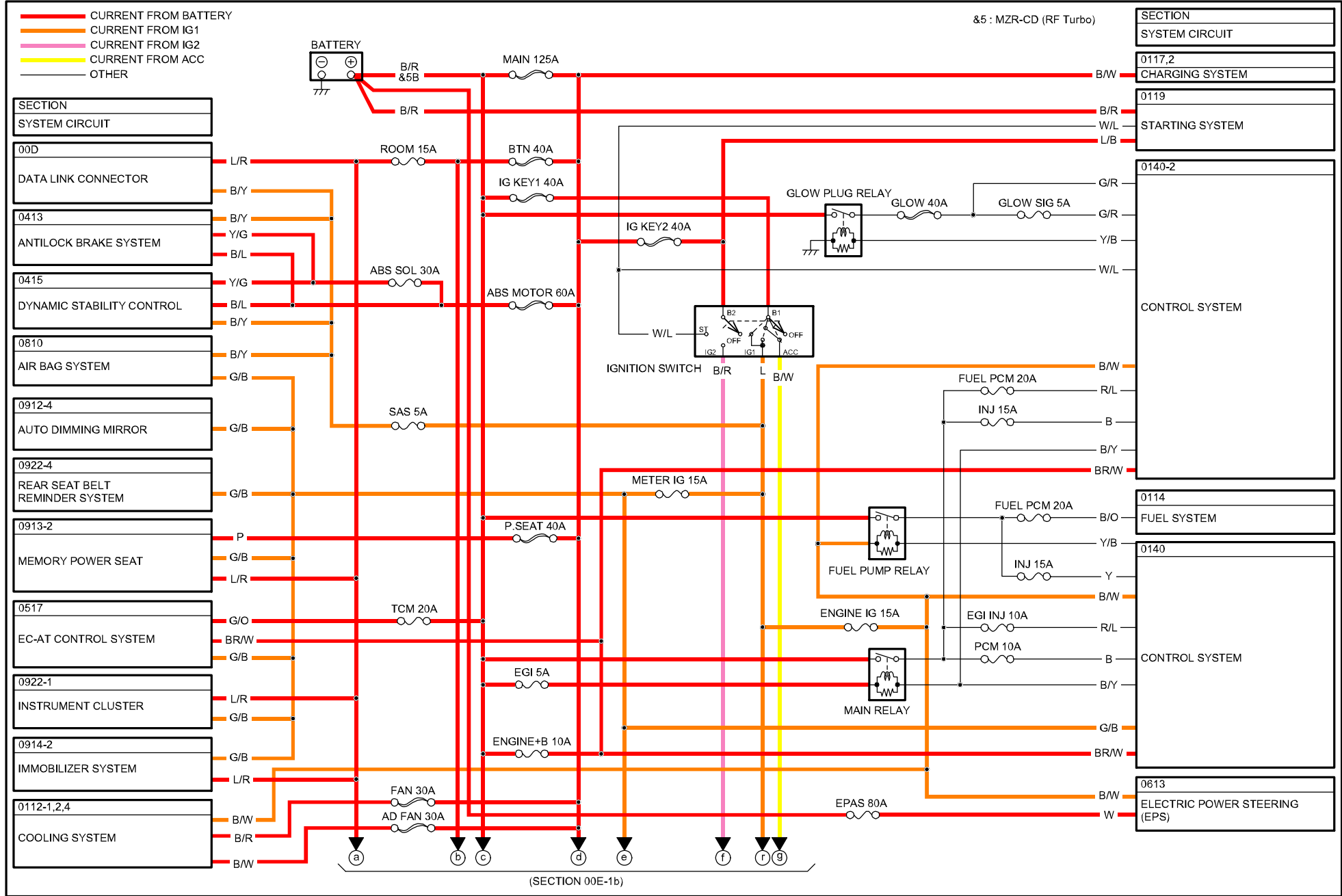

ELECTRICAL WIRING SCHEMATIC (WITHOUT ADVANCED KEYLESS SYSTEM)

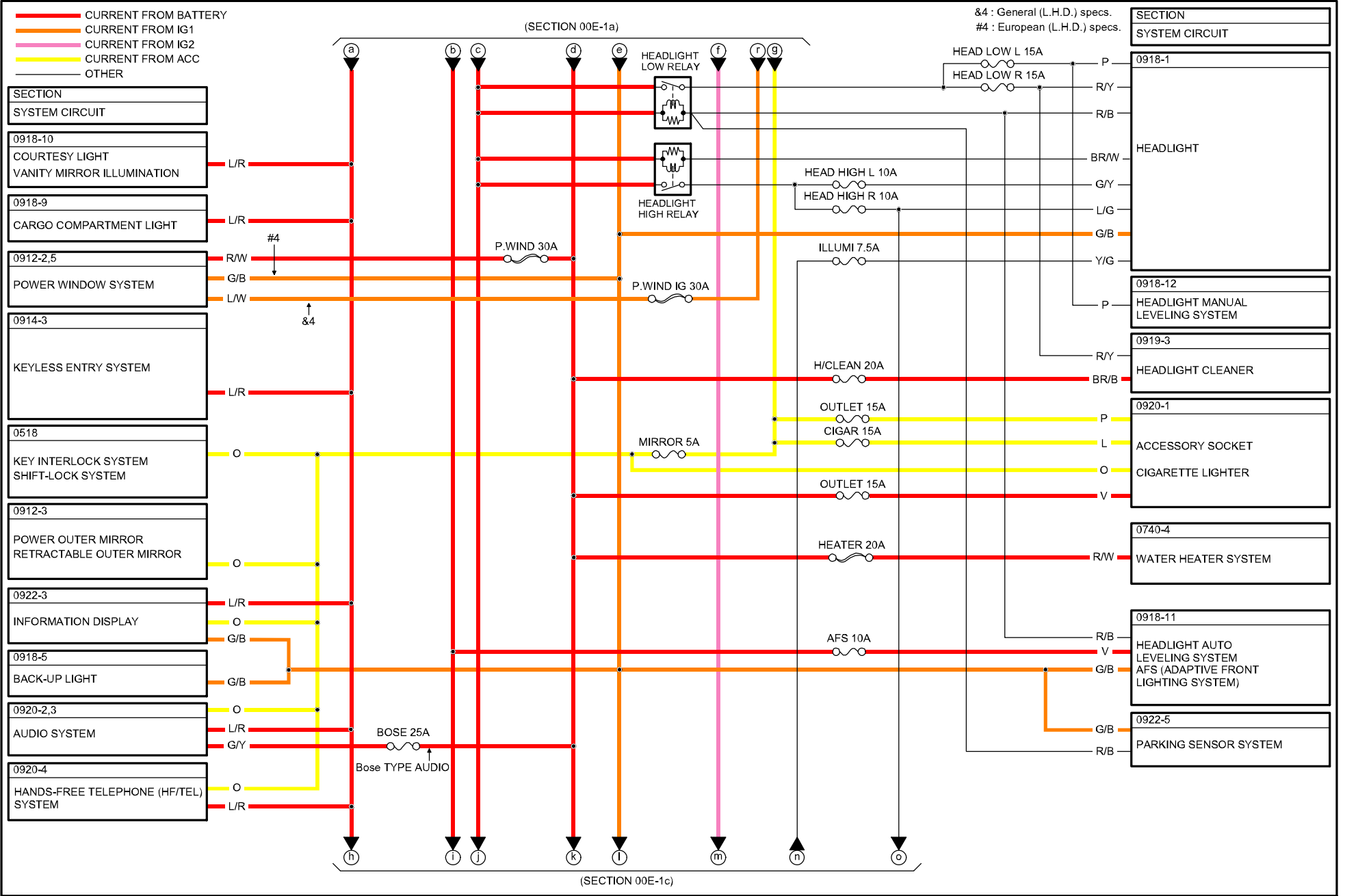

ELECTRICAL WIRING SCHEMATIC (WITHOUT ADVANCED KEYLESS SYSTEM)

00E-1c

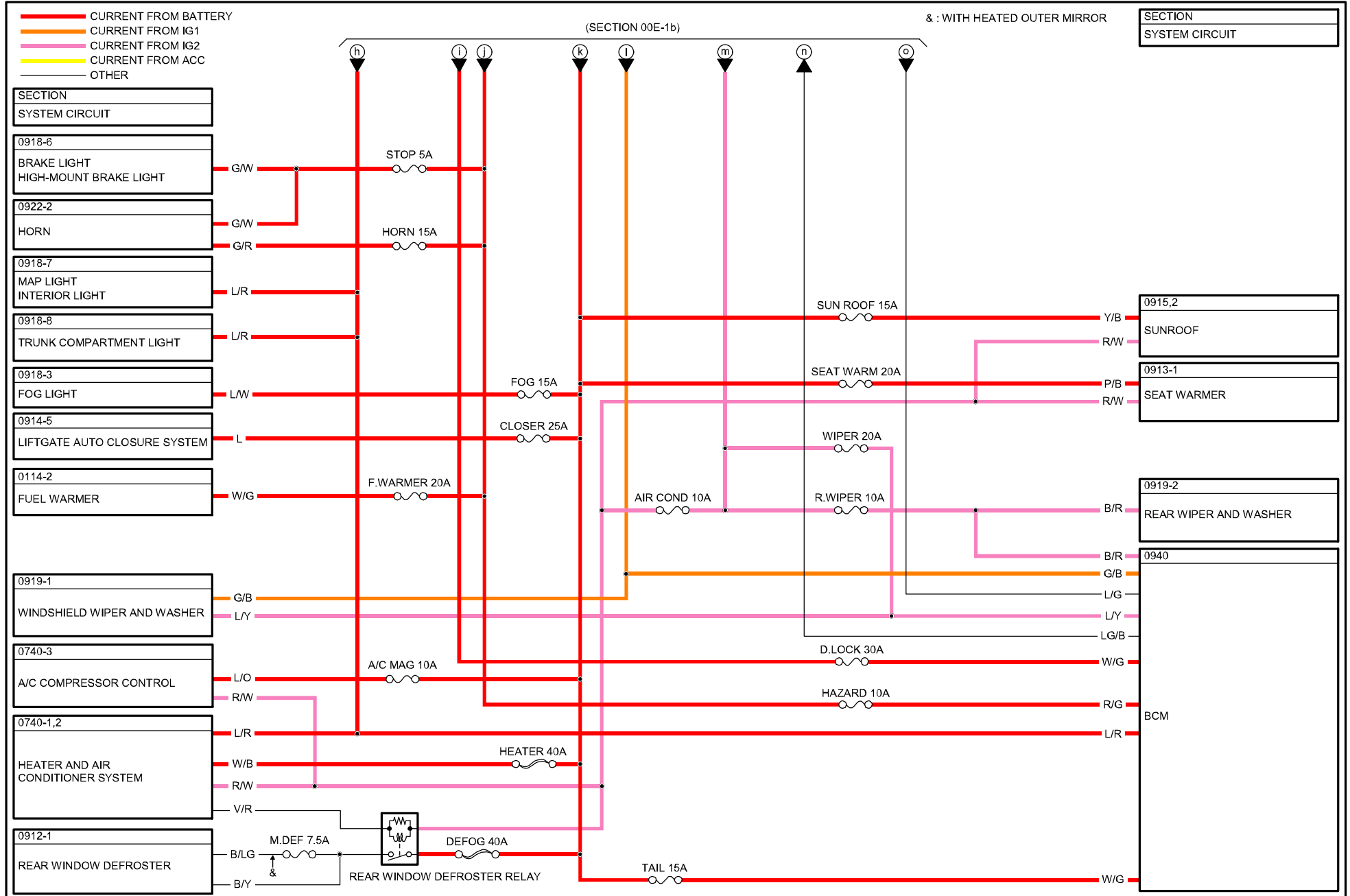

ELECTRICAL WIRING SCHEMATIC (WITH ADVANCED KEYLESS SYSTEM)

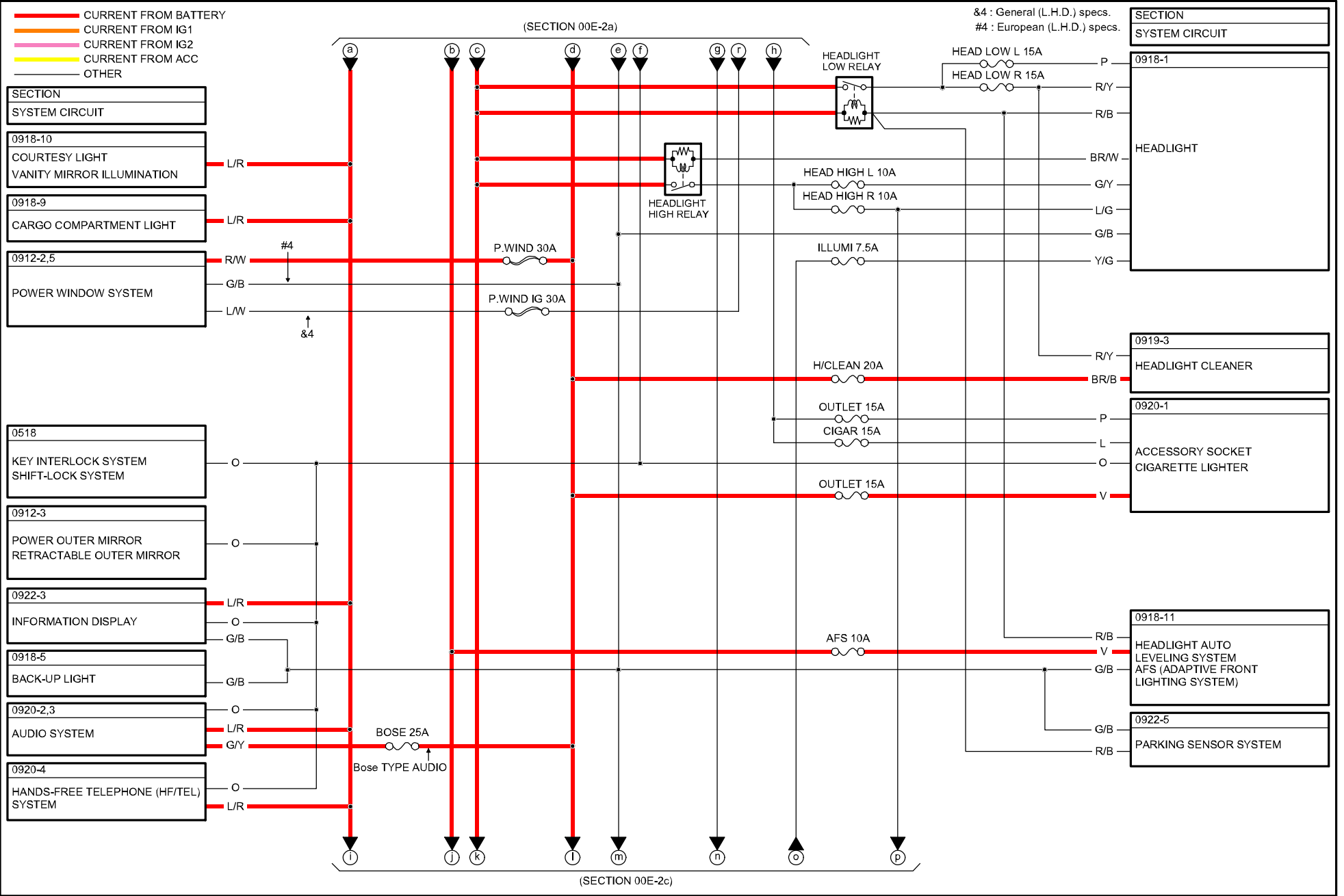

ELECTRICAL WIRING SCHEMATIC (WITH ADVANCED KEYLESS SYSTEM)

00E-2c

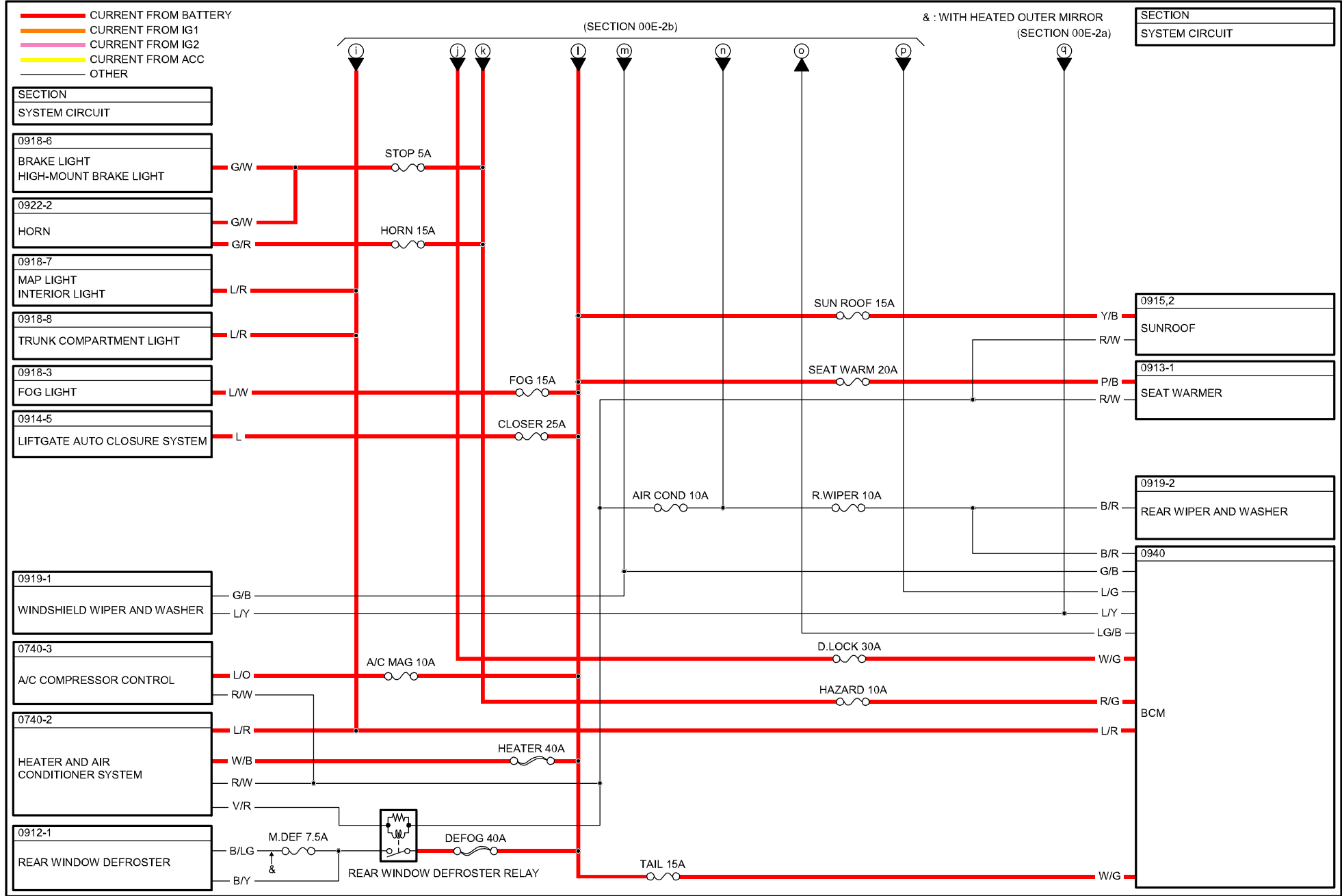

F-01
MAIN FUSE BLOCK

- < > : NOT USED
- () : IF EQUIPPED
- @2 : WITH ADVANCED KEYLESS SYSTEM
- @3 : WITH THREE COOLING FAN RELAYS
- @4 : WITH FOUR COOLING FAN RELAYS
- &5 : MZR-CD (RF Turbo)

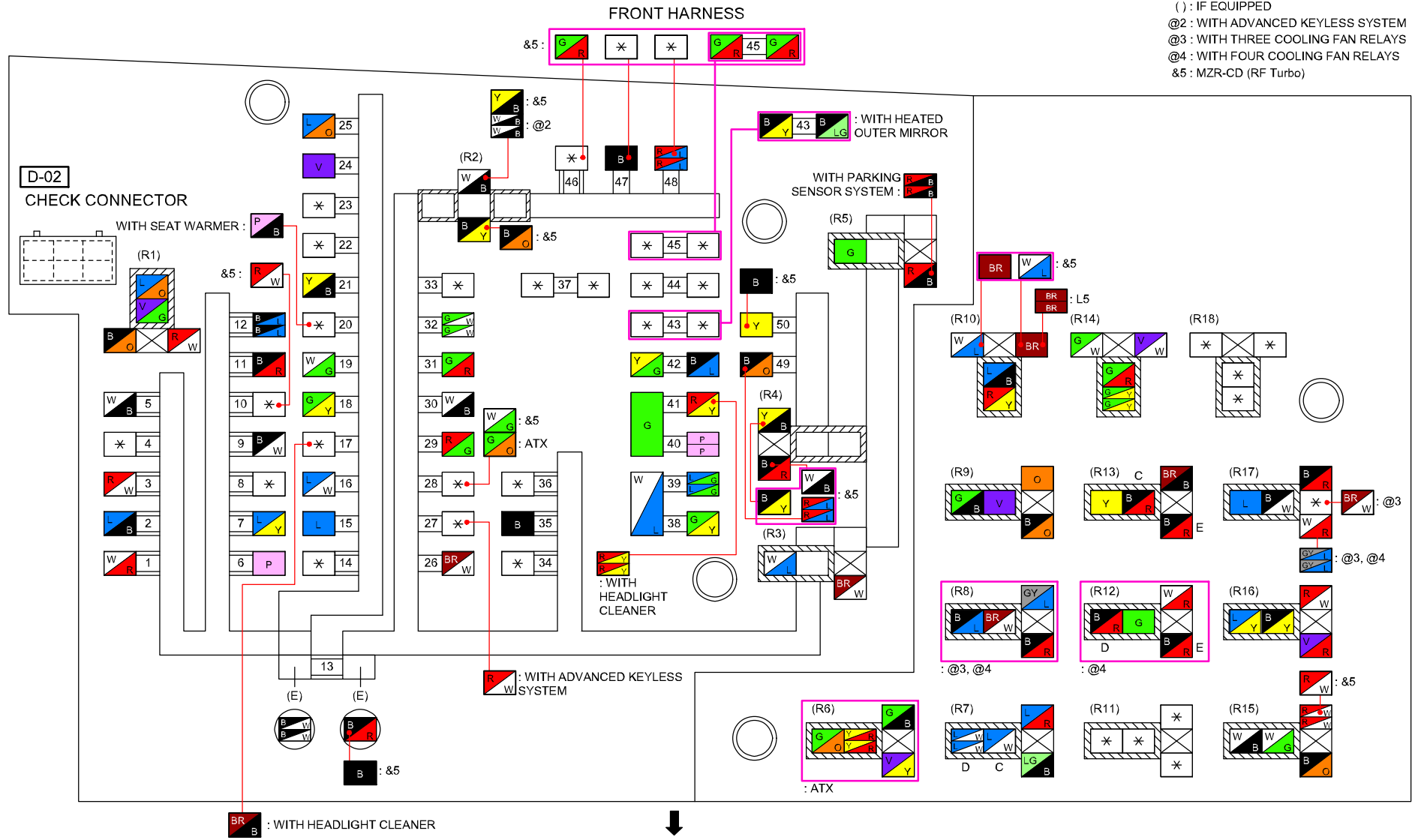

FRONT
NOTE: SEEN FROM TERMINAL SIDE

NO.	FUSE NAME	FUSE	NO.	FUSE NAME	FUSE
1	BTN	40A	26	ENGINE+B	10A
2	IG KEY2	40A	27	(STEERING LOCK)	(10A)
3	P.WIND	30A	28	(TCM) (F.WARMER)	(20A)
4	<PTC>	<40A>	29	HAZARD	10A
5	HEATER	40A	30	EGI	5A
6	P.SEAT	40A	31	HORN	15A
7	DEFOG	40A	32	STOP	5A
8	<PRECRASH>	<50A>	33	*	*
9	AD FAN	30A	34	*	*
10	<AUX> (HEATER)	(20A)	35	IG KEY1	40A
11	FAN	30A	36	*	*
12	ABS MOTOR	60A	37	*	*
13	MAIN	125A	38	HEAD HIGH L	10A
14	*	*	39	HEAD HIGH R	10A
15	(CLOSER)	(25A)	40	HEAD LOW L	15A
16	FOG	15A	41	HEAD LOW R	15A
17	(H/CLEAN)	(20A)	42	ABS SOL	30A
18	(BOSE)	(25A)	43	(M.DEF)	(7.5A)
19	TAIL	15A	44	*	*
20	(SEAT WARM)	(20A)	45	(GLOW SIG)	(5A)
21	(SUN ROOF)	(15A)	46	(GLOW)	(40A)
22	*	*	47	(PCM)	(10A)
23	<DEICER>	<15A>	48	(EGI INJ)	(10A)
24	(OUTLET)	(15A)	49	FUEL PCM	20A
25	A/C MAG	10A	50	INJ	15A

<> : NOT USED
() : IF EQUIPPED

NO.	RELAY NAME	NO.	RELAY NAME
(R1)	A/C RELAY {A/C RELAY}	(R10)	STARTER RELAY {STARTER RELAY}
(R2)	MAIN RELAY ← EXCEPT &5 {EGI MAIN <GLOW> RELAY} GLOW PLUG RELAY ← &5 {<EGI MAIN> GLOW RELAY}	(R11)	* {DEICER RELAY}
(R3)	HEADLIGHT HIGH RELAY {HEAD HIGH RELAY}	(R12)	(COOLING FAN RELAY NO.4 {AD FAN#3 <BURGLAR> RELAY})
(R4)	FUEL PUMP RELAY ← EXCEPT &5 {<EGI MAIN> FUEL PUMP RELAY} MAIN RELAY ← &5 {EGI MAIN <FUEL PUMP> RELAY}	(R13)	COOLING FAN RELAY NO.1 {FAN RELAY}
(R5)	HEADLIGHT LOW RELAY {HEAD LOW RELAY}	(R14)	HORN RELAY {HORN RELAY}
(R6)	AT MAIN RELAY {AT MAIN <STARTER2> RELAY}	(R15)	BLOWER RELAY {HEATER RELAY}
(R7)	FRONT FOG LIGHT RELAY {FOG RELAY}	(R16)	REAR WINDOW DEFROSTER RELAY {DEFOG RELAY}
(R8)	(COOLING FAN RELAY NO.2 {FAN#2 RELAY})	(R17)	COOLING FAN RELAY NO.2 {COOLING FAN RELAY NO.3] {AD FAN RELAY}
(R9)	(OUTLET RELAY {OUTLET RELAY})	(R18)	* {BACK RELAY}

{ } : NAME INDICATED ON FUSE BOX COVER
[] : WITH THREE COOLING FAN RELAYS, WITH FOUR COOLING FAN RELAYS
<> : NOT USED
() : IF EQUIPPED
&5 : MZR-CD (RF Turbo)

F-02
FUSE BLOCK

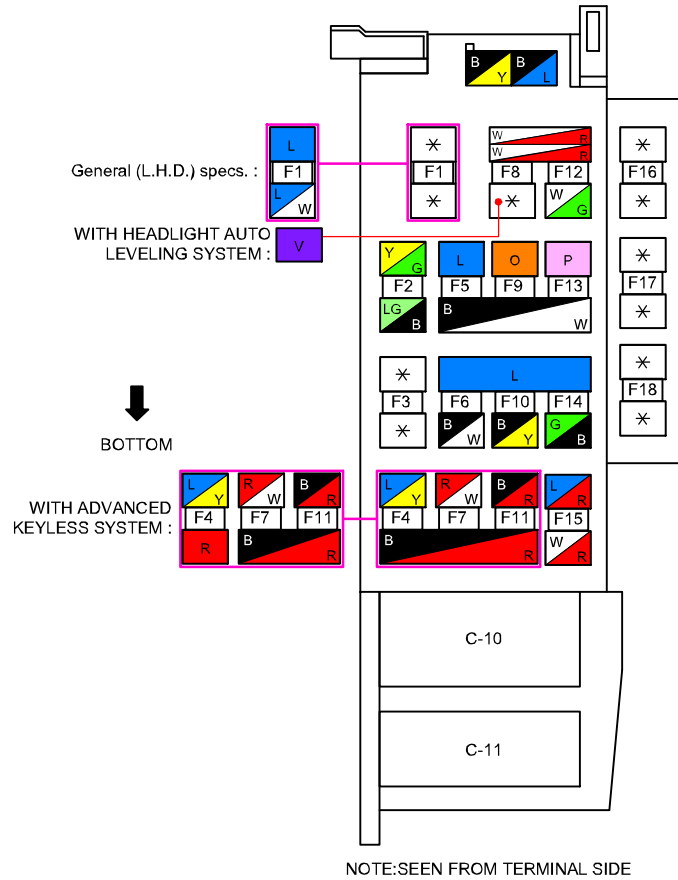

NO.	FUSE NAME	FUSE	NO.	FUSE NAME	FUSE
F1	(P.WIND IG)	(30A)	F10	SAS	5A
F2	ILLUMI	7.5A	F11	(R.WIPER)	(10A)
F3	*	*	F12	D.LOCK	30A
F4	WIPER	20A	F13	OUTLET	15A
F5	CIGAR	15A	F14	METER IG	15A
F6	ENGINE IG	15A	F15	ROOM	15A
F7	AIR COND	10A	F16	SPARE	*
F8	(AFS)	(10A)	F17	SPARE	*
F9	MIRROR	5A	F18	SPARE	*

(): IF EQUIPPED
< > : NOT USED

F-03
MAIN FUSE

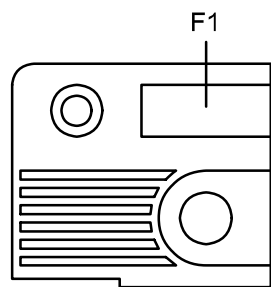

NO.	FUSE NAME	FUSE
F1	EPAS	80A

GROUND POINT

G01

JOINT CONNECTOR

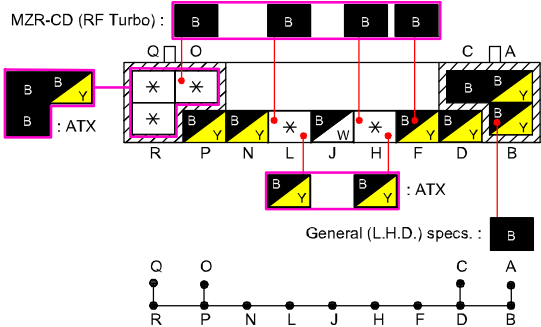

G02

JOINT CONNECTOR

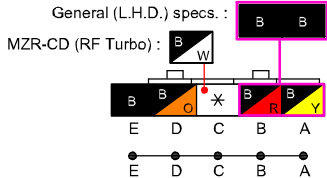

G07

JOINT CONNECTOR

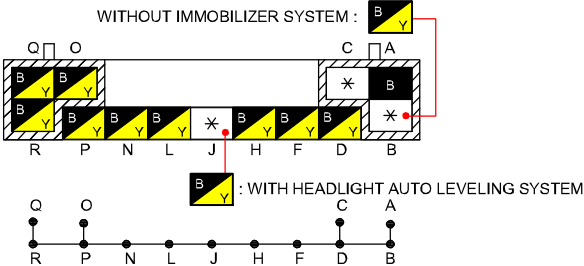

&4 : General (L.H.D.) specs.
 &5 : MZR-CD (RF Turbo)
 @5 : WITH HEADLIGHT AUTO LEVELING SYSTEM

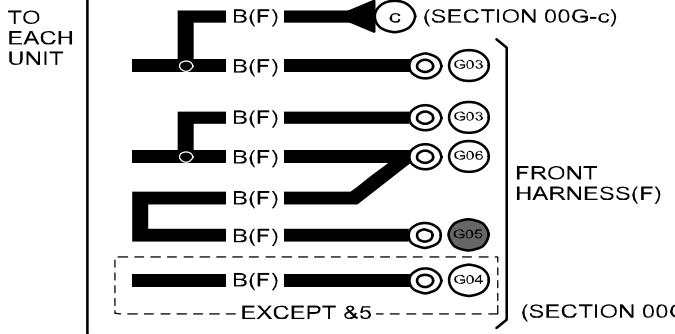
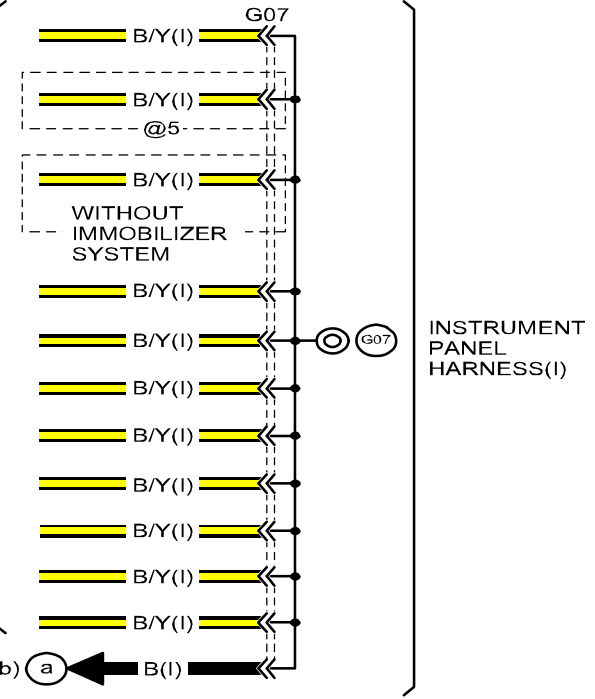
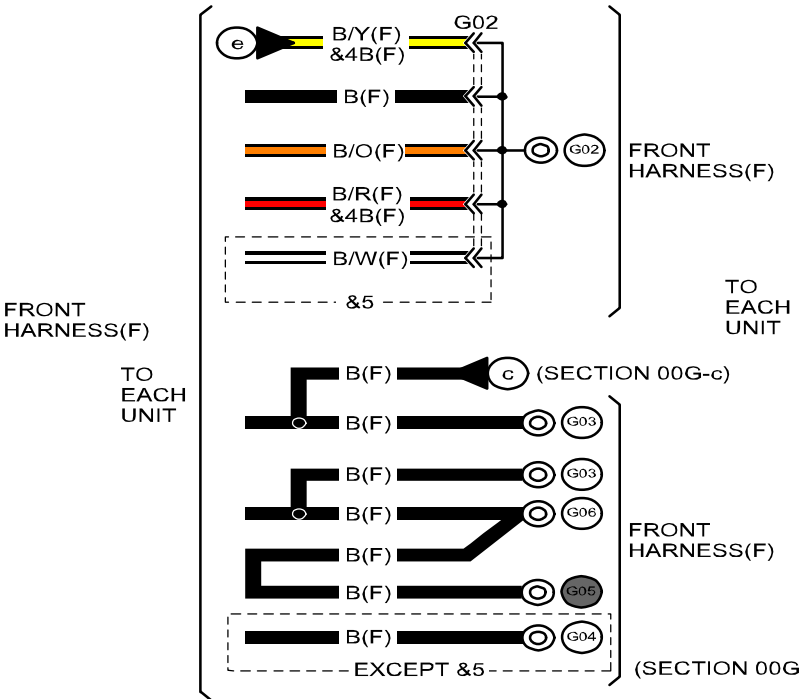
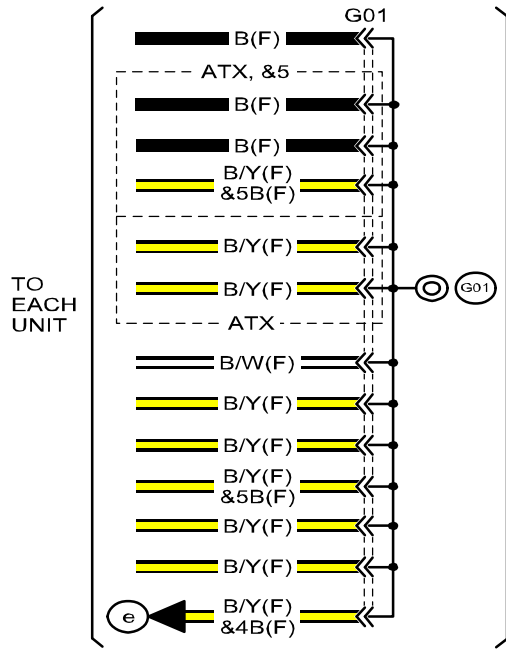

(SECTION 00G-b)

(SECTION 00G-c)

EXCEPT &5

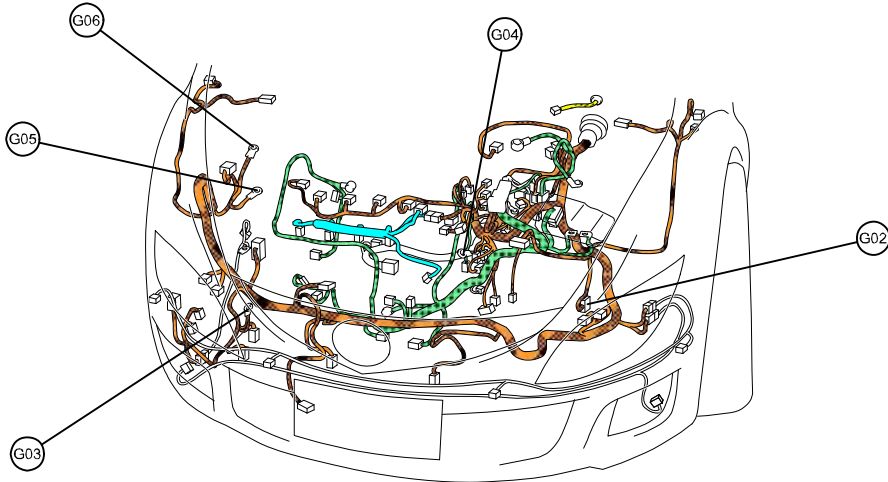



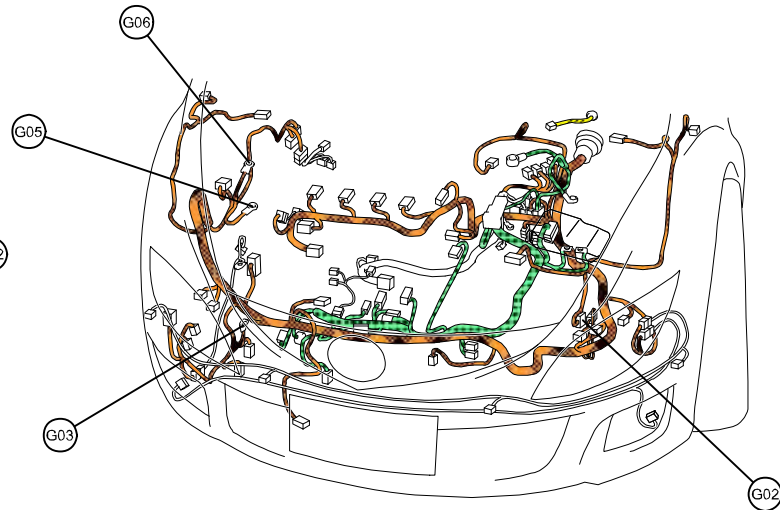



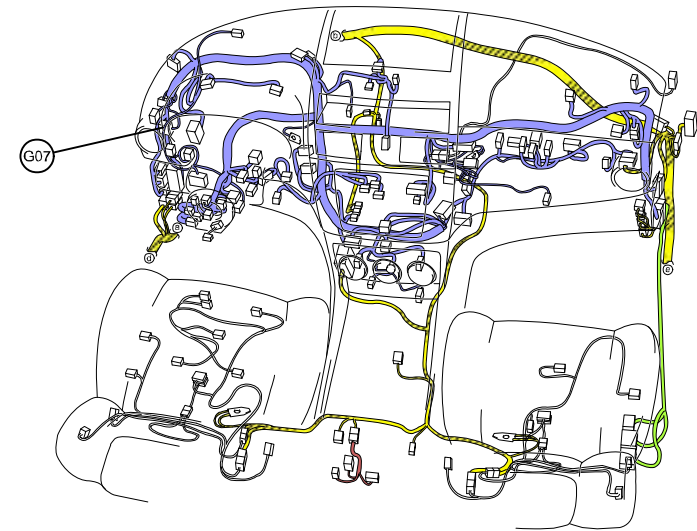
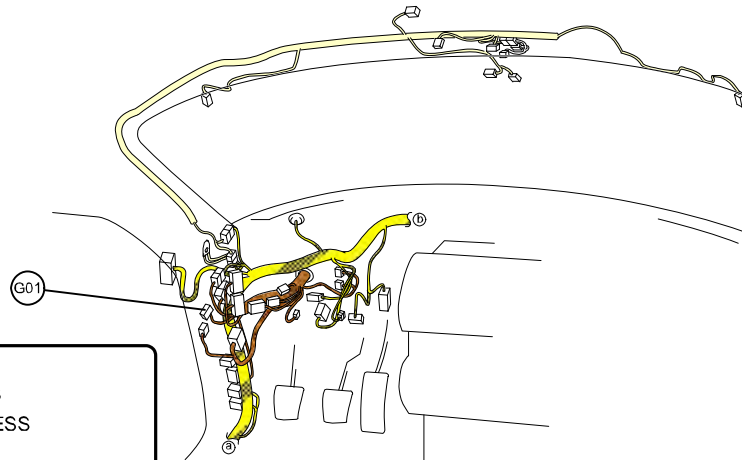

[EXCEPT MZR-CD (RF Turbo)]



[MZR-CD (RF Turbo)]



- | | |
|---|-------------------------------|
|  | : FRONT HARNESS |
|  | : ENGINE HARNESS |
|  | : INJECTION HARNESS |
|  | : REAR HARNESS |
|  | : REAR NO.5 HARNESS |
|  | : INSTRUMENT PANEL HARNESS |
|  | : FLOOR HARNESS |
|  | : INTERIOR LIGHT NO.2 HARNESS |

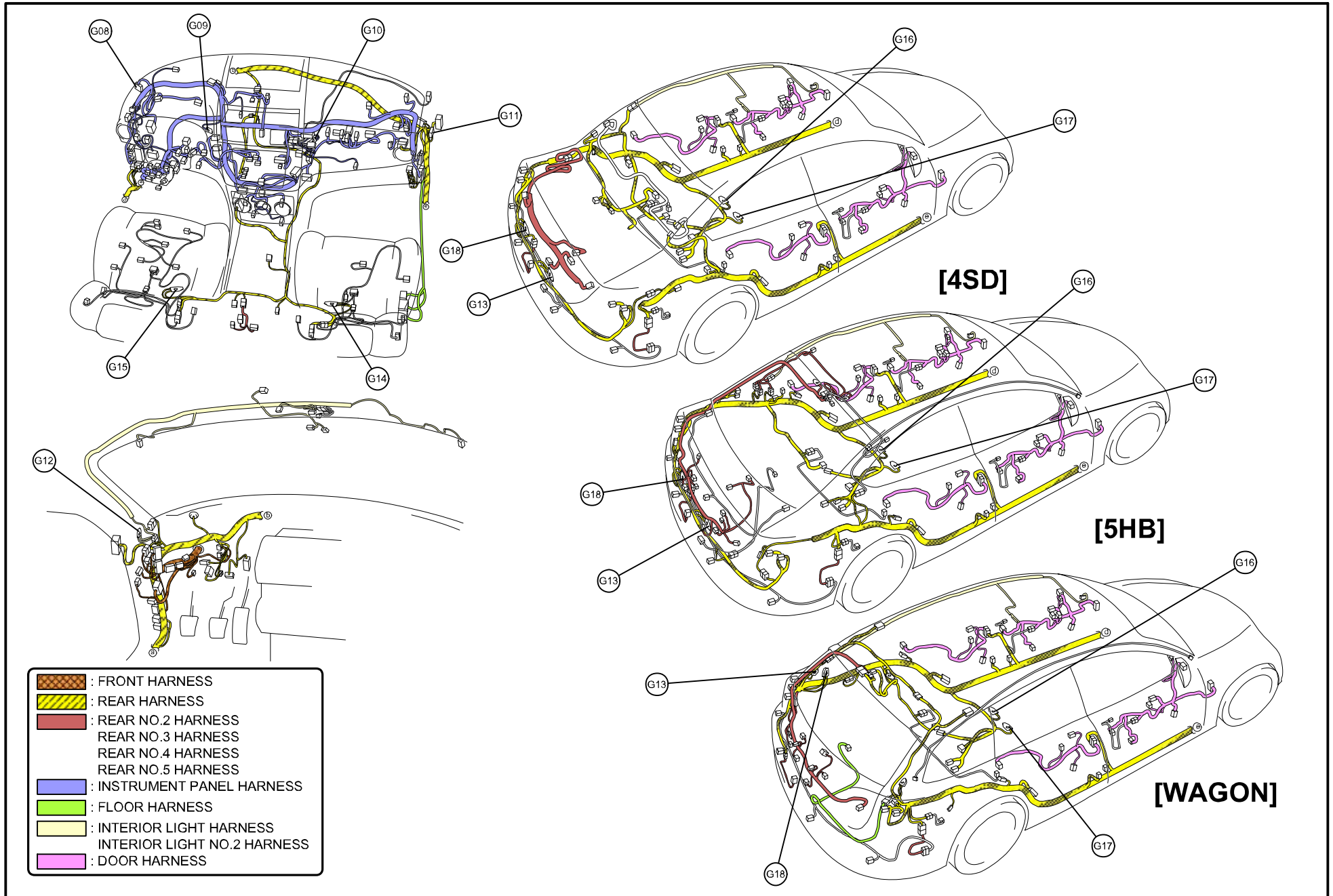







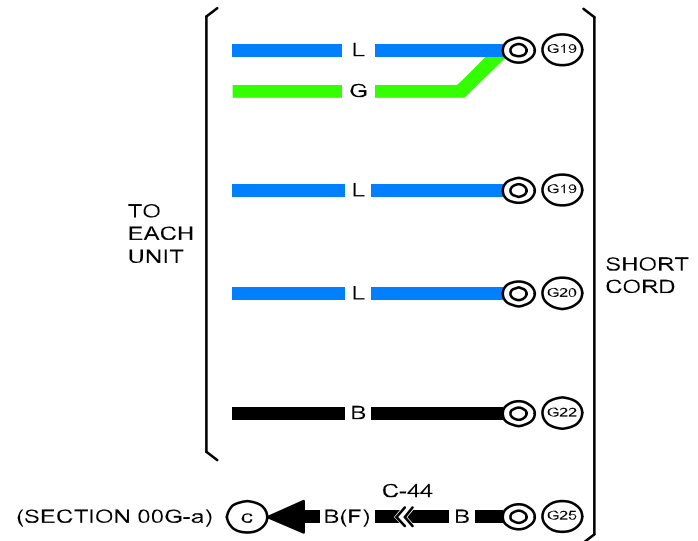
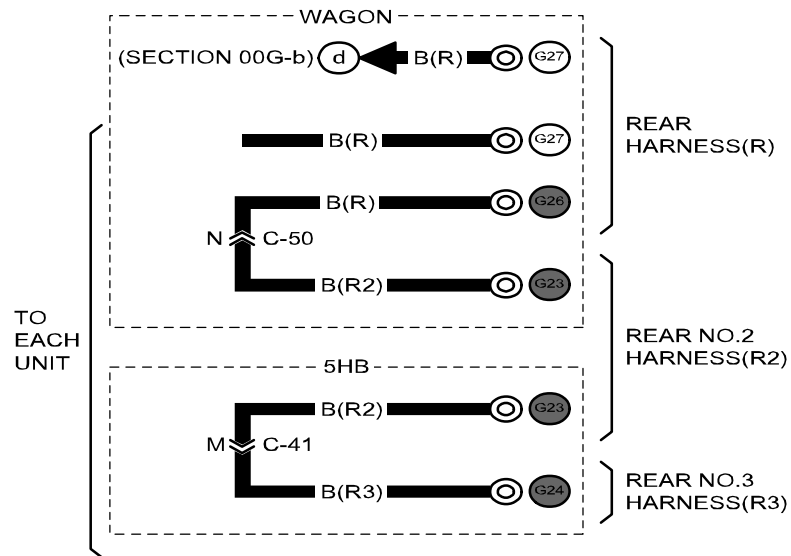



GROUND POINT

00G-c

<p>G19</p>		<p>G20</p>	<p>G22</p>	<p>G23</p>
<p>G24</p>	<p>G25</p>	<p>G26</p>	<p>G27</p>	<p>G27</p>



-  : FRONT HARNESS
-  : ENGINE HARNESS
-  : INJECTION HARNESS
-  : REAR HARNESS
-  : REAR NO.2 HARNESS
-  : REAR NO.3 HARNESS
-  : REAR NO.4 HARNESS
-  : DOOR HARNESS
-  : INTERIOR LIGHT HARNESS
-  : FLOOR HARNESS

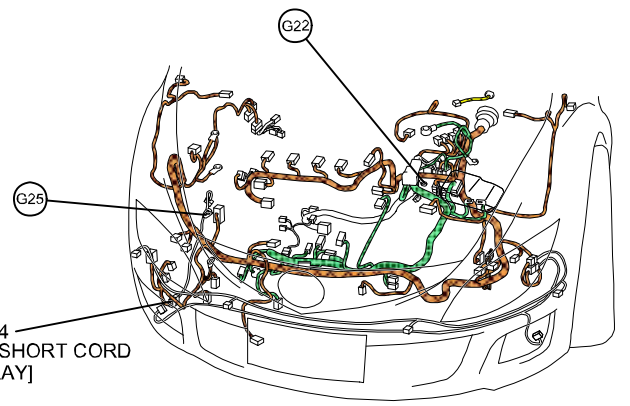
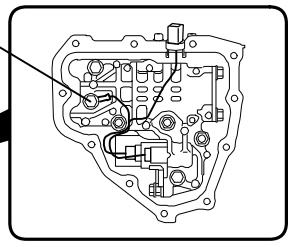
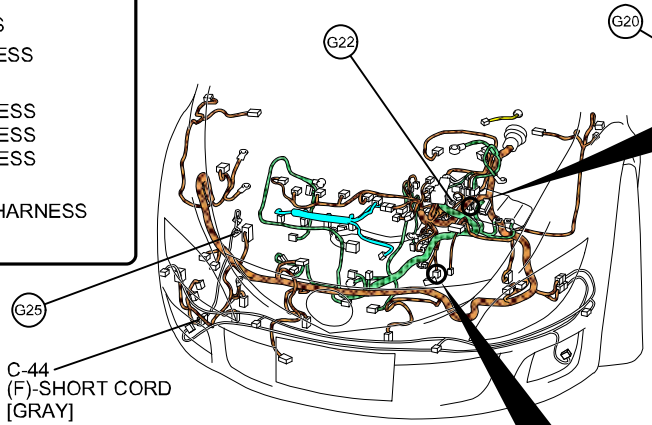

[EXCEPT MZR-CD (RF Turbo)]

[MZR-CD (RF Turbo)]

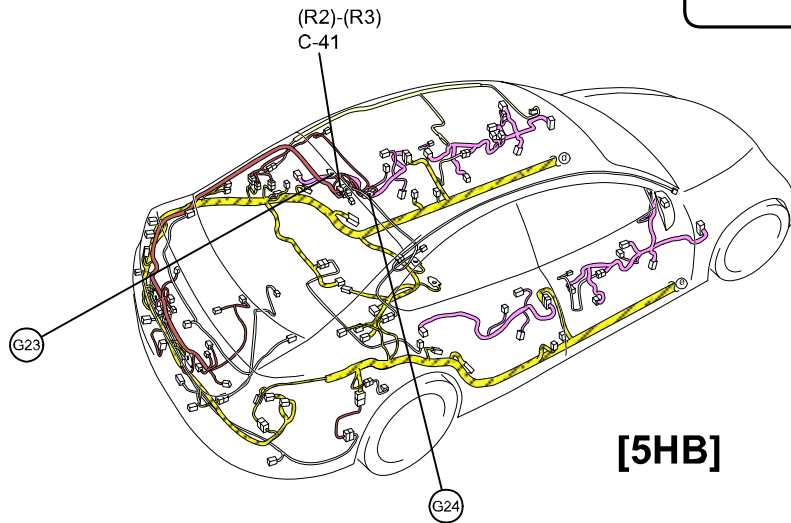
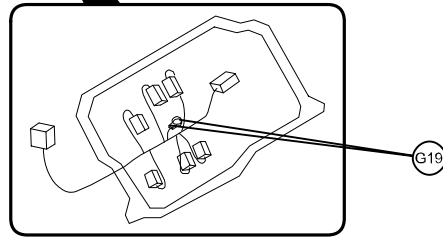

[5HB]

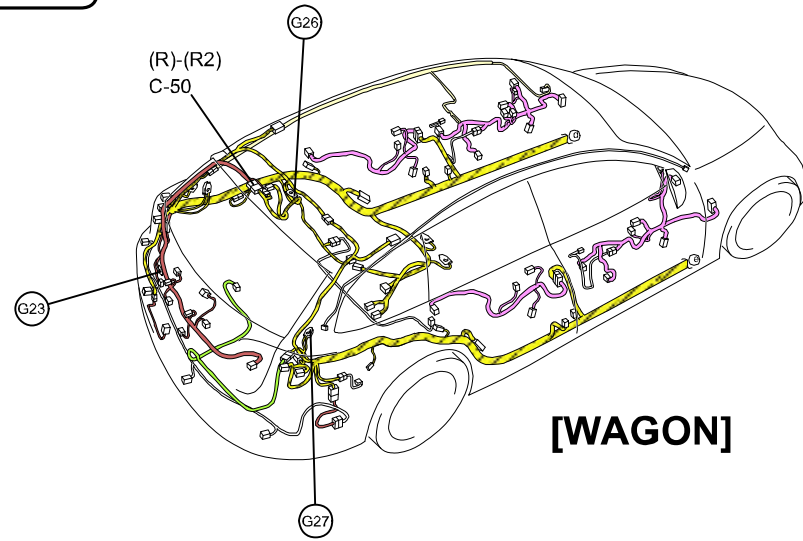

[WAGON]

GROUND POINT

C-41
REAR NO.2 HARNESS-REAR NO.3 HARNESS

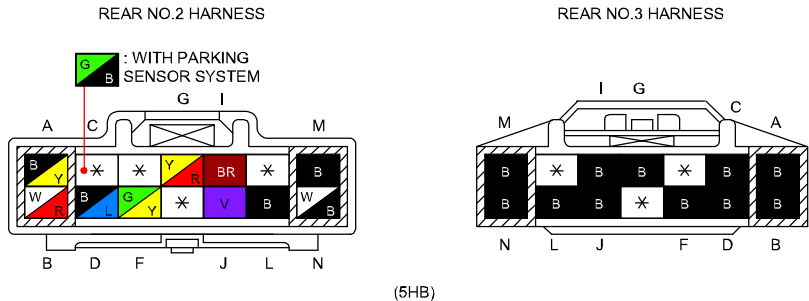

C-44
FRONT HARNESS-SHORT CORD

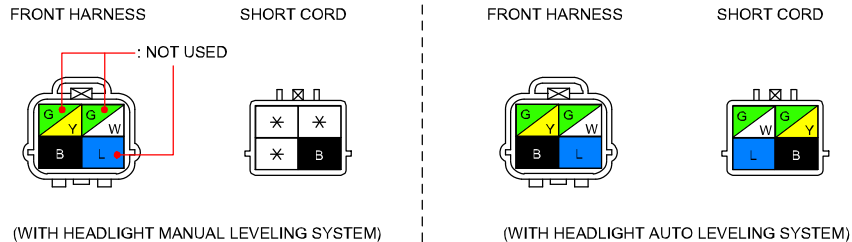

C-50
REAR HARNESS-REAR NO.2 HARNESS



DATA LINK CONNECTOR

00D-a

&5 : MZR-CD (RF Turbo)

00D-b

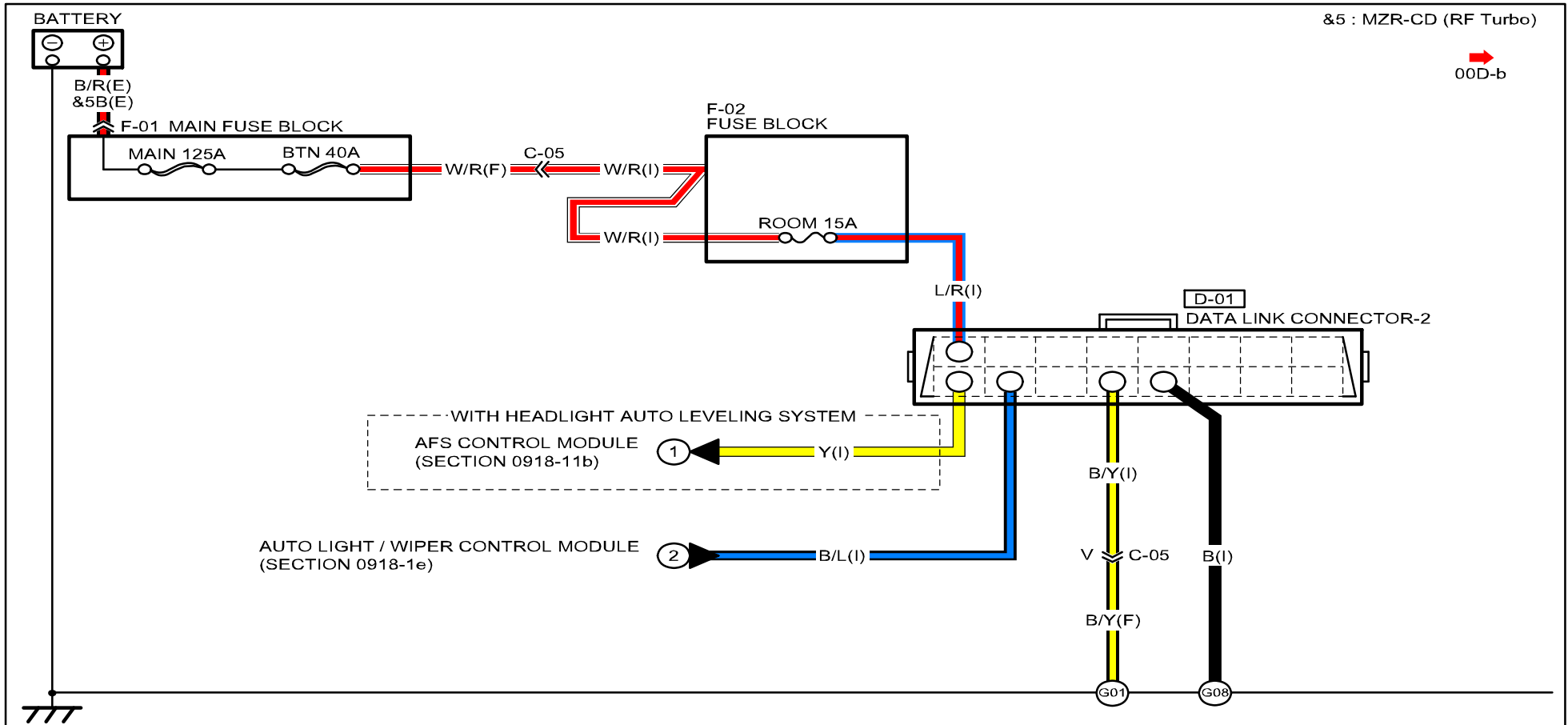

D-01
DATA LINK CONNECTOR-2

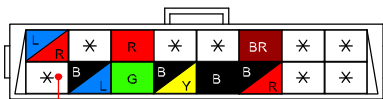

Y : WITH HEADLIGHT AUTO LEVELING SYSTEM

NOTE : SEEN FROM TERMINAL SIDE

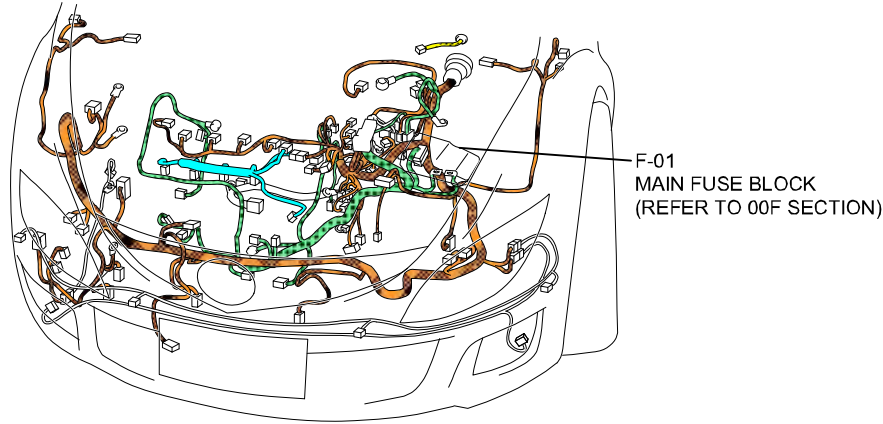



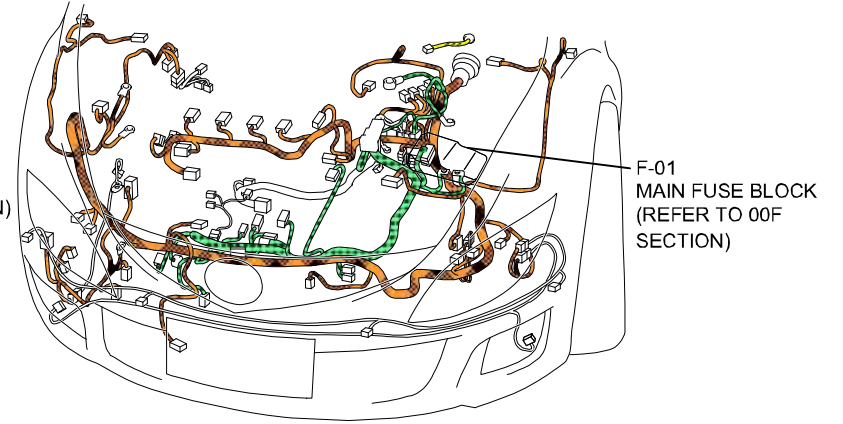



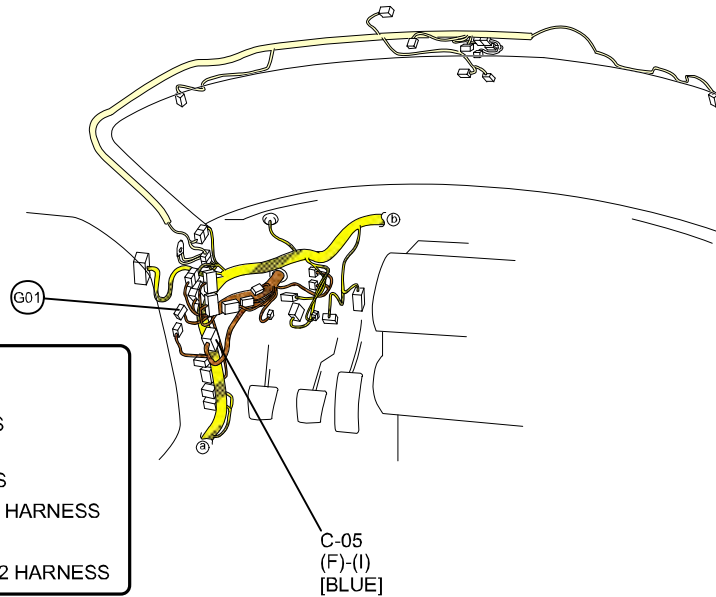

[EXCEPT MZR-CD (RF Turbo)]



[MZR-CD (RF Turbo)]



-  : FRONT HARNESS
-  : ENGINE HARNESS
-  : INJECTION HARNESS
-  : REAR HARNESS
-  : REAR NO.5 HARNESS
-  : INSTRUMENT PANEL HARNESS
-  : FLOOR HARNESS
-  : INTERIOR LIGHT NO.2 HARNESS

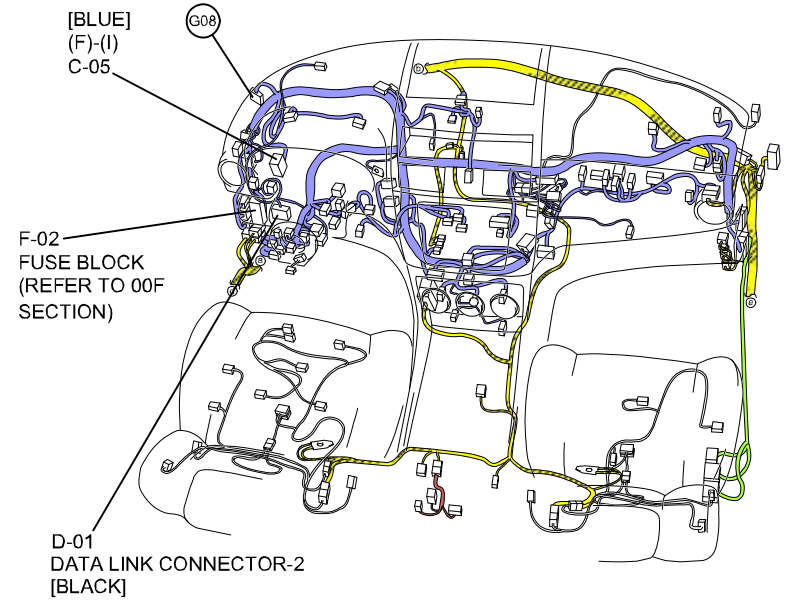

DATA LINK CONNECTOR

00D-a

C-05
FRONT HARNESS-INSTRUMENT PANEL HARNESS

FRONT HARNESS

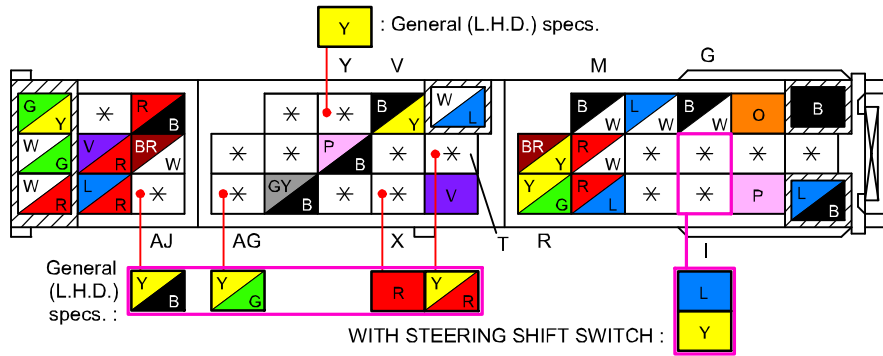

INSTRUMENT PANEL HARNESS

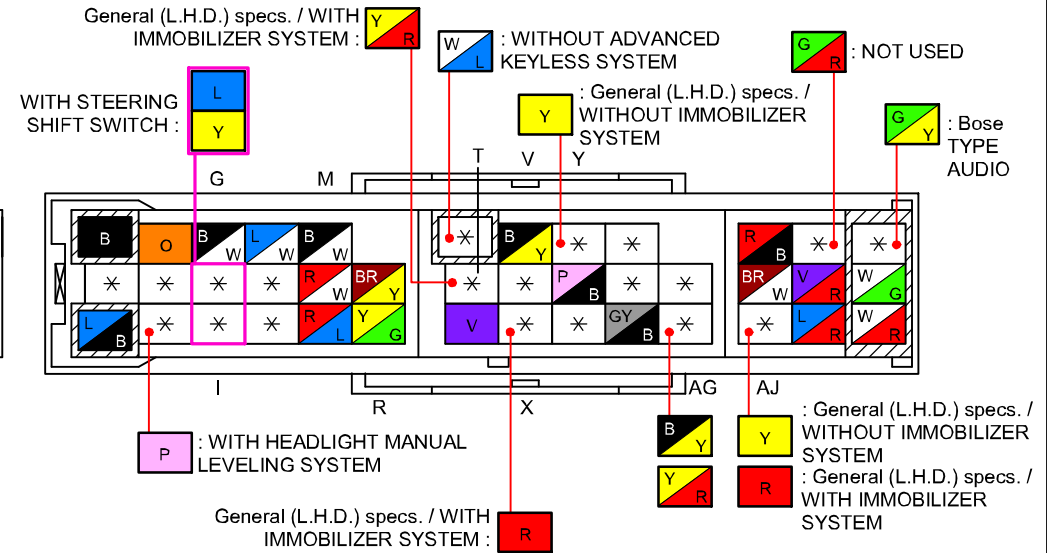



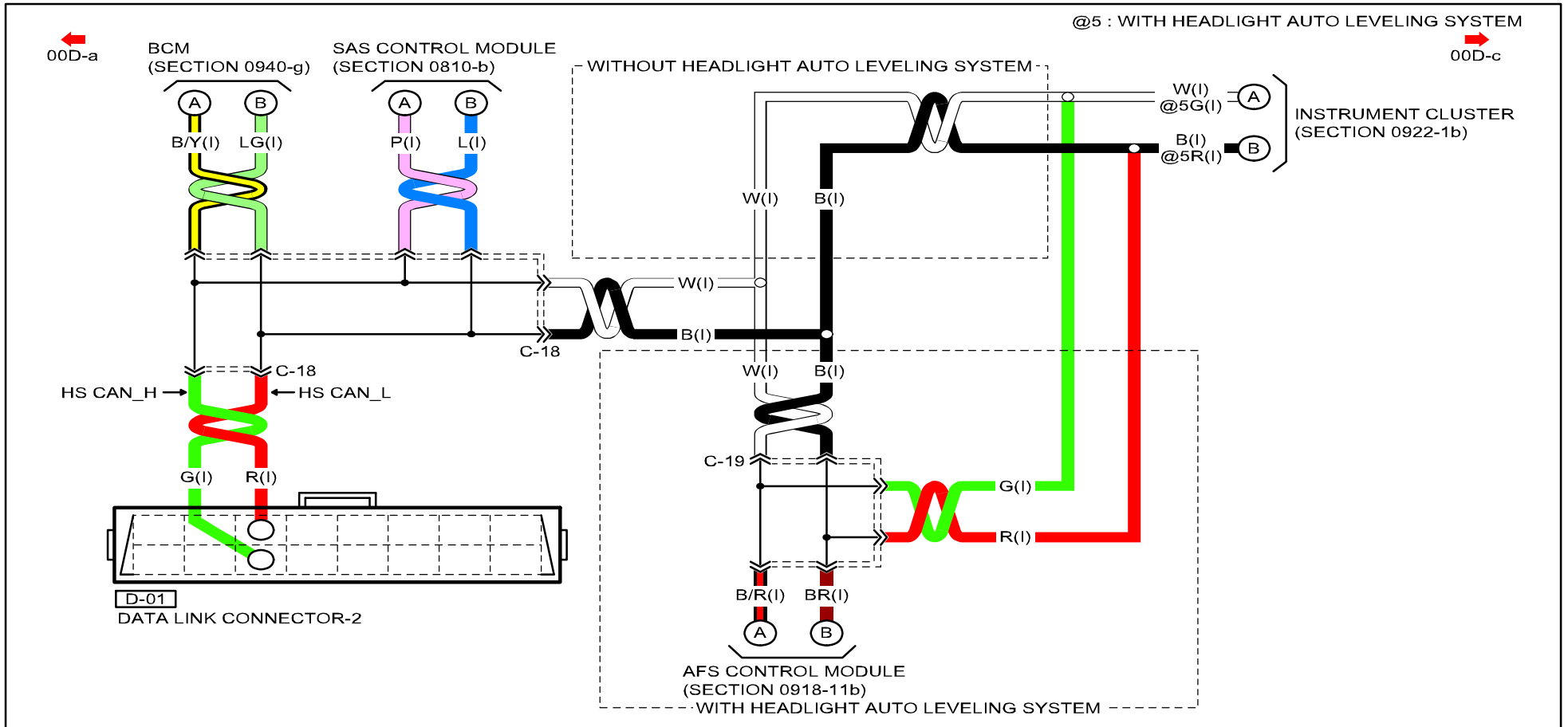

DATA LINK CONNECTOR

00D-b

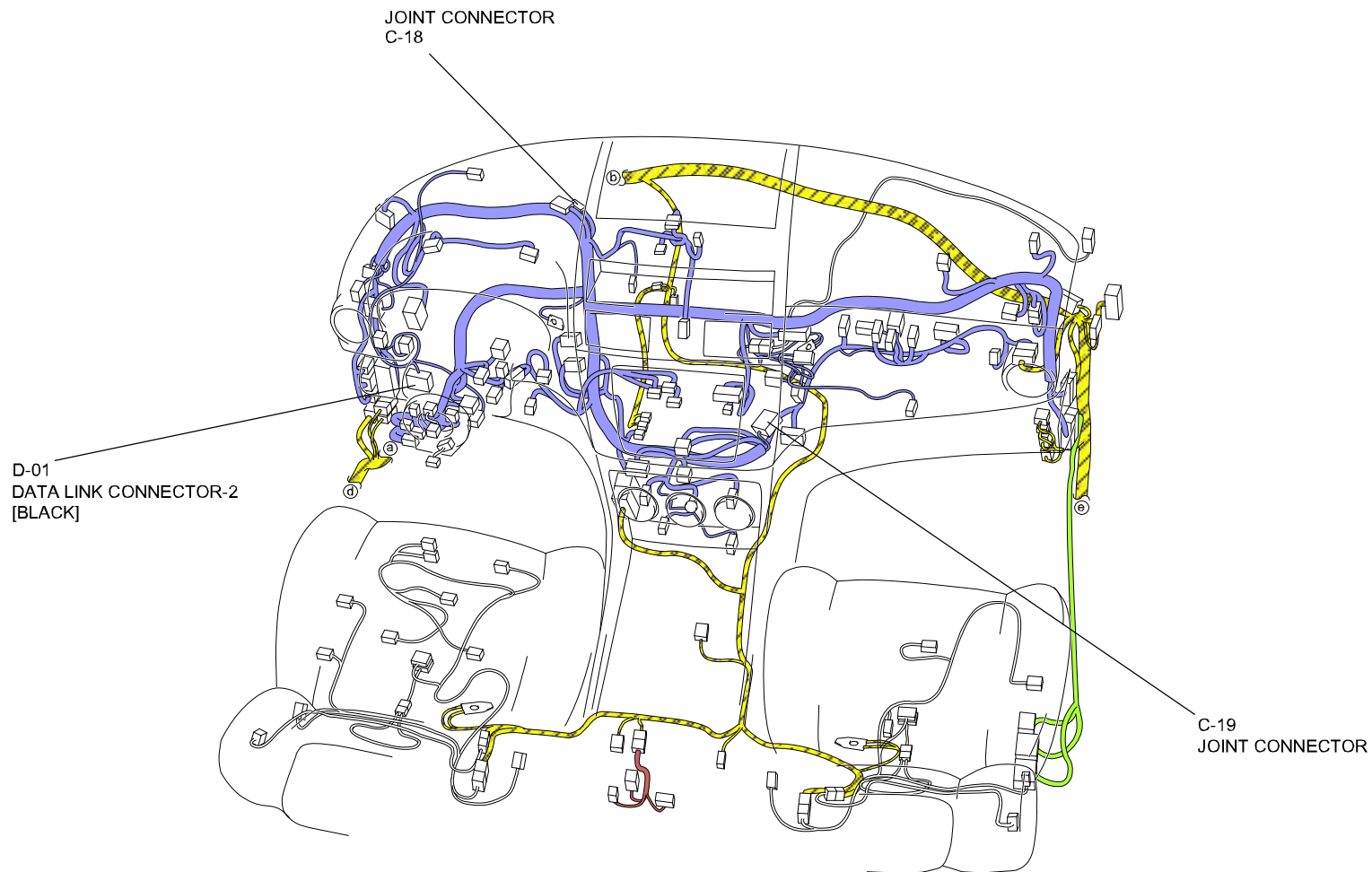

<p>D-01 DATA LINK CONNECTOR-2</p> <p>Y : WITH HEADLIGHT AUTO LEVELING SYSTEM</p> <p>NOTE : SEEN FROM TERMINAL SIDE</p>					



-  : REAR HARNESS
-  : REAR NO.5 HARNESS
-  : INSTRUMENT PANEL HARNESS
-  : FLOOR HARNESS

DATA LINK CONNECTOR

00D-b

C-18
JOINT CONNECTOR

INSTRUMENT PANEL HARNESS

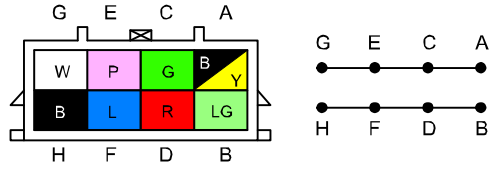

C-19
JOINT CONNECTOR

INSTRUMENT PANEL HARNESS

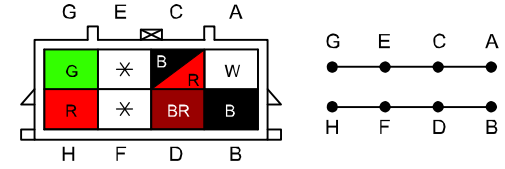

(WITH HEADLIGHT AUTO LEVELING SYSTEM)

← 00D-b

00D-d →

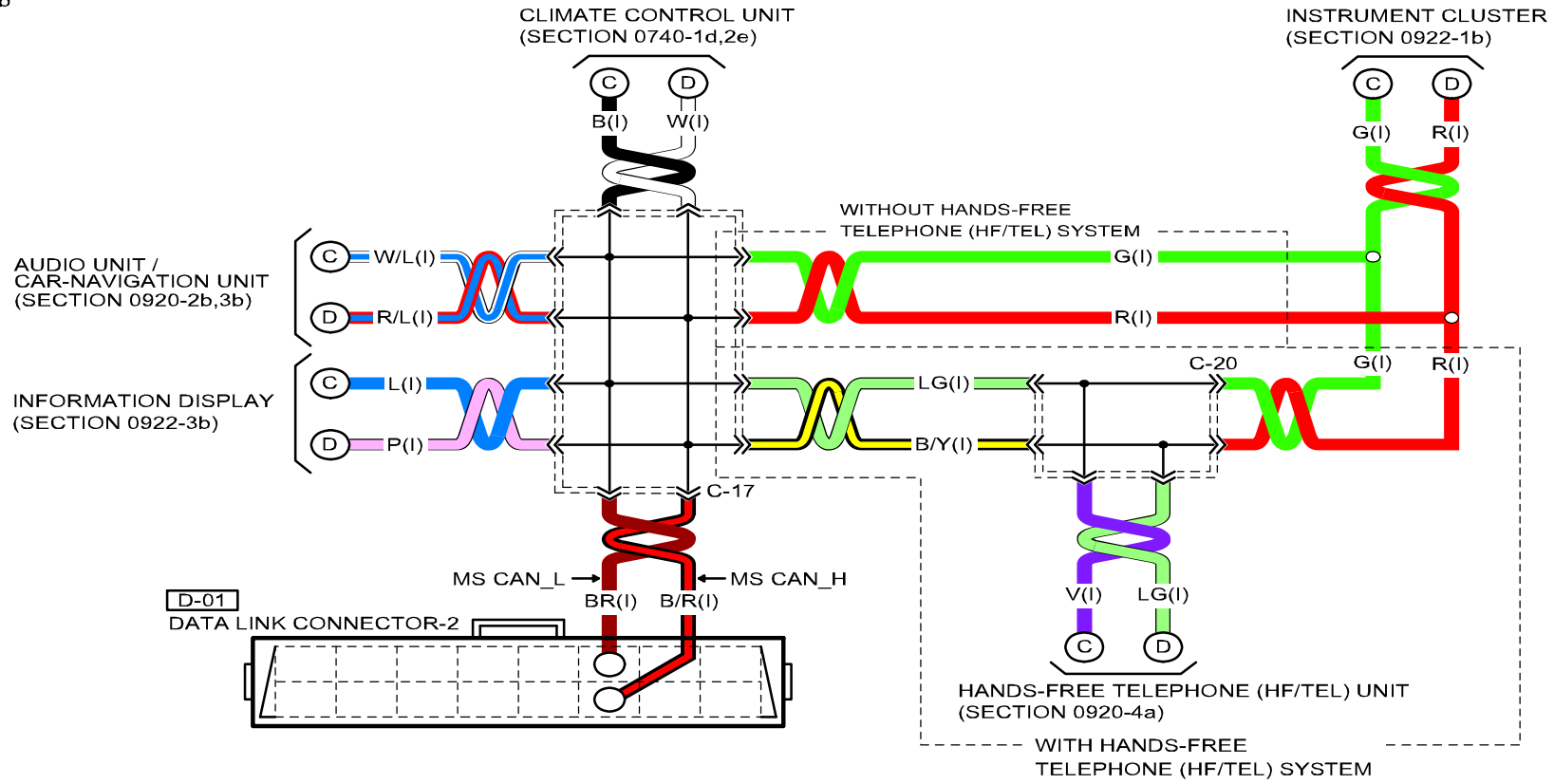



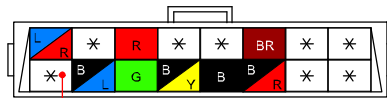

D-01
DATA LINK CONNECTOR-2

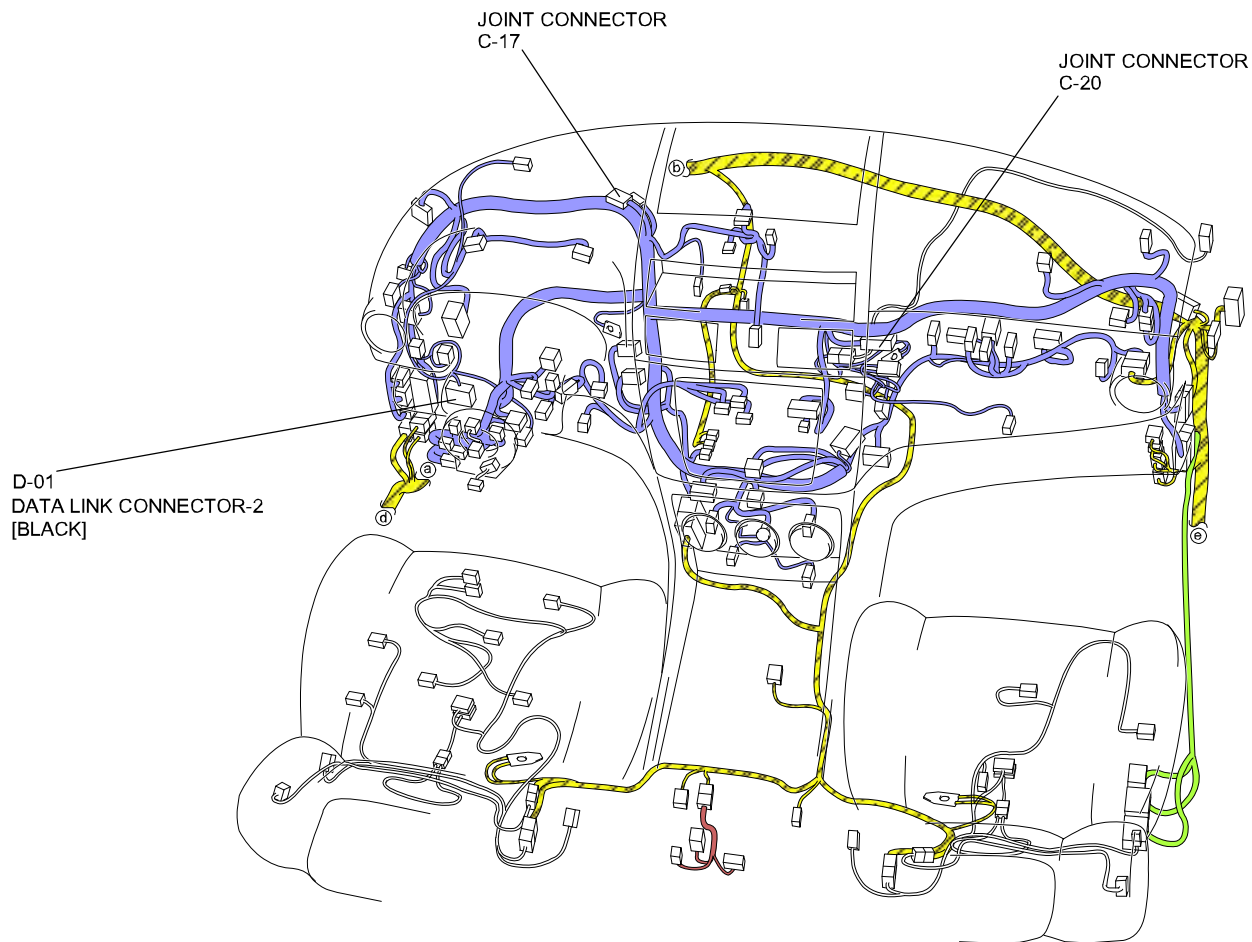

Y : WITH HEADLIGHT AUTO LEVELING SYSTEM

NOTE : SEEN FROM TERMINAL SIDE



-  : REAR HARNESS
-  : REAR NO.5 HARNESS
-  : INSTRUMENT PANEL HARNESS
-  : FLOOR HARNESS

DATA LINK CONNECTOR

C-17
JOINT CONNECTOR

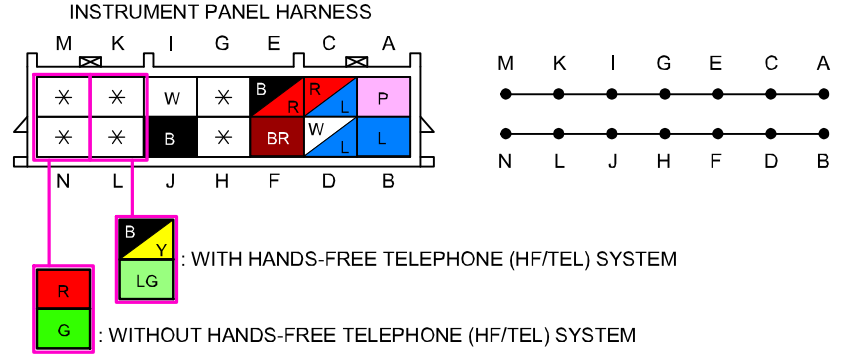

C-20
JOINT CONNECTOR

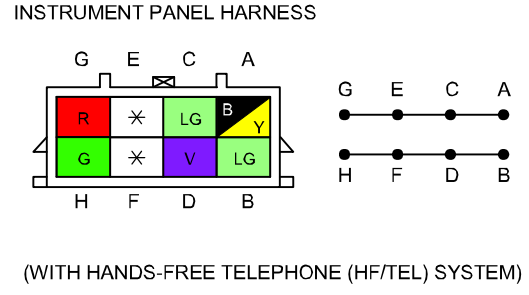

DATA LINK CONNECTOR

00D-d

&5 : MZR-CD (RF Turbo)
 @ : ATX / EXCEPT TAIWAN
 PCM (SECTION 0140-I,2e)

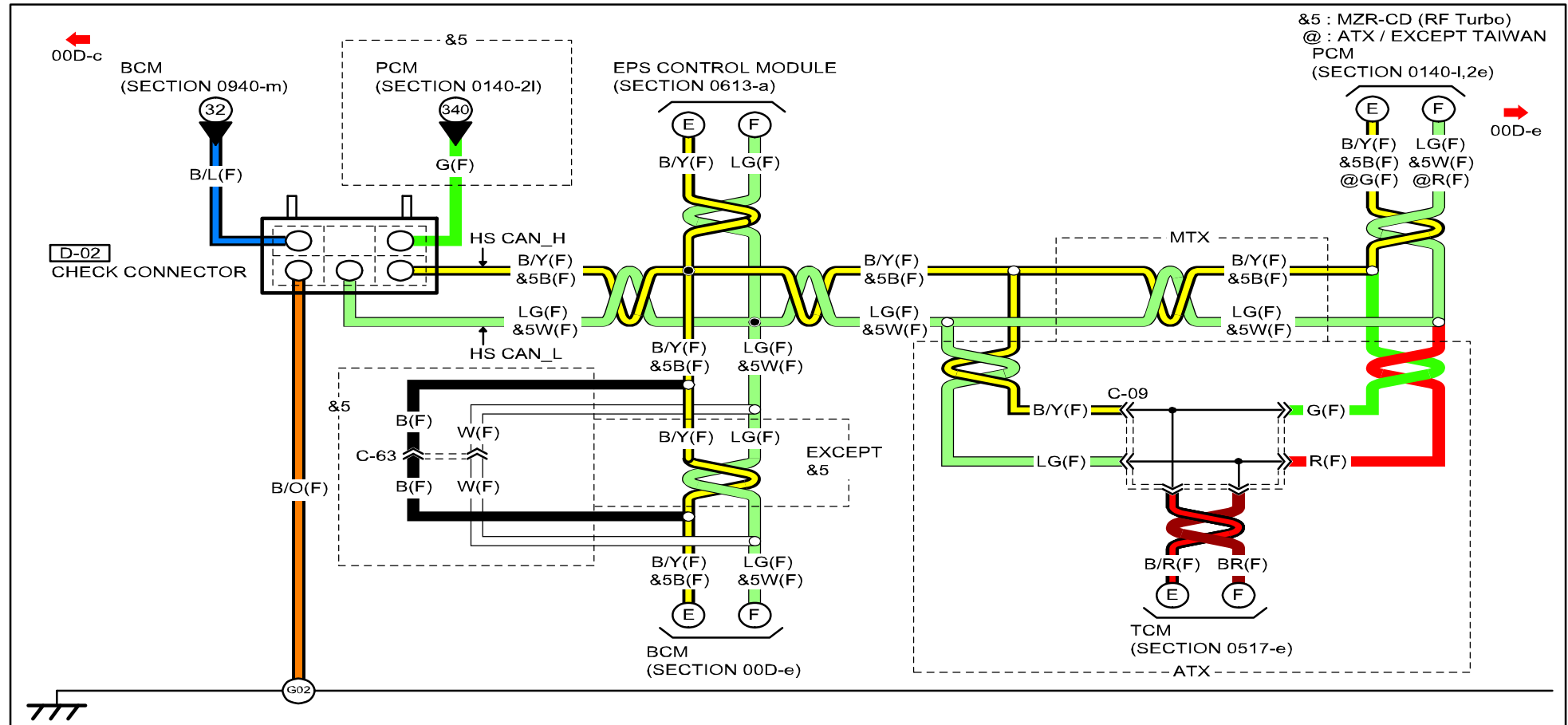

<p>D-02 CHECK CONNECTOR</p>  <p>: MZR-CD (RF Turbo)</p> <p>NOTE : SEEN FROM TERMINAL SIDE</p>					

DATA LINK CONNECTOR

00D-d

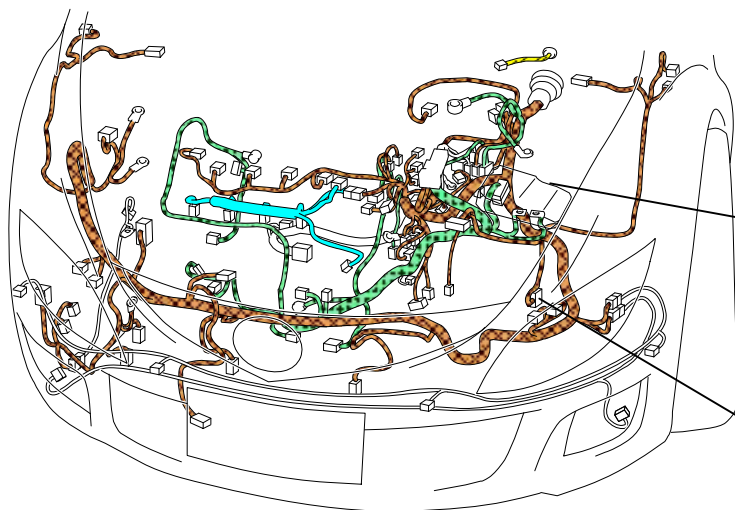

D-02
CHECK CONNECTOR
(REFER TO 00F SECTION)

G02

[EXCEPT MZR-CD (RF Turbo)]

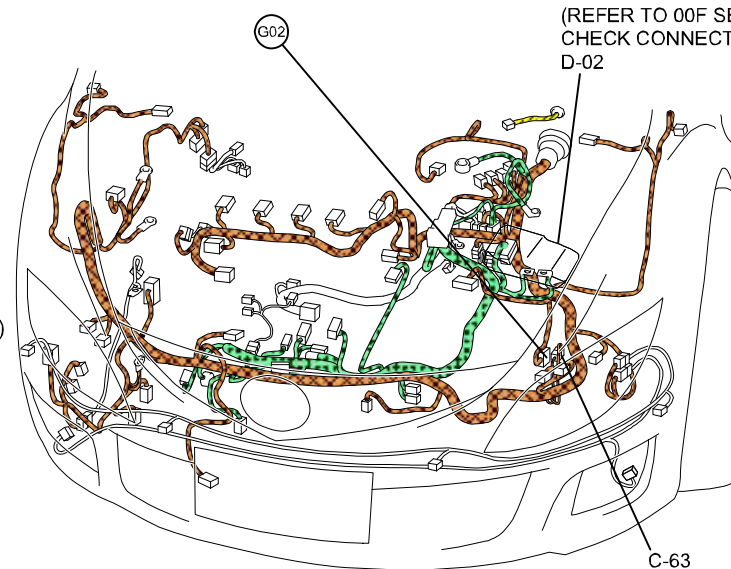

(REFER TO 00F SECTION)
CHECK CONNECTOR
D-02

C-63
SHORT
CONNECTOR
[BLACK]

[MZR-CD (RF Turbo)]

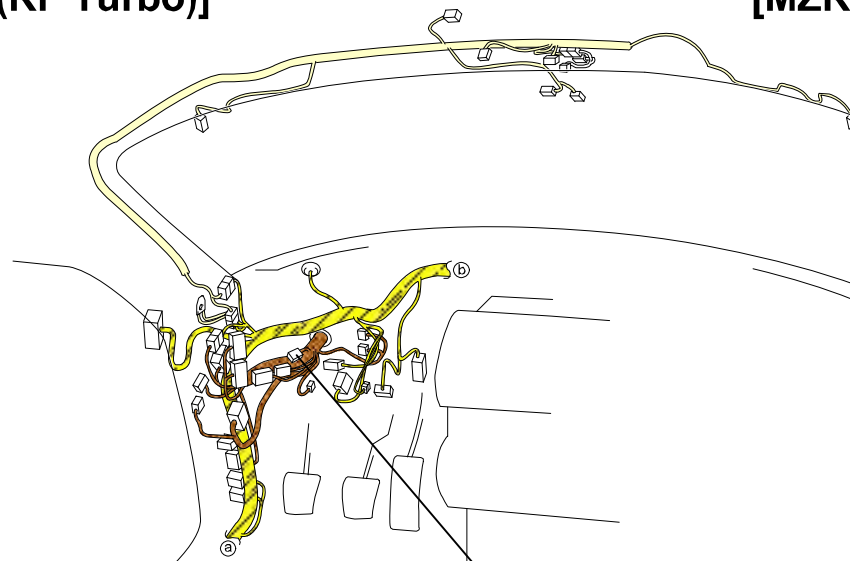

C-09
JOINT CONNECTOR

- : FRONT HARNESS
- : ENGINE HARNESS
- : INJECTION HARNESS
- : REAR HARNESS
- : INTERIOR LIGHT NO.2 HARNESS

DATA LINK CONNECTOR

00D-d

C-09
JOINT CONNECTOR

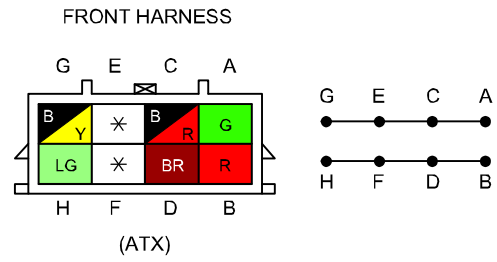

C-63
SHORT CONNECTOR

FRONT HARNESS

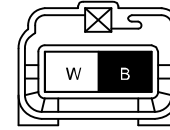

FRONT HARNESS

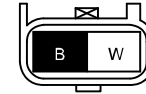

(MZR-CD (RF Turbo))

DATA LINK CONNECTOR

00D-e

← CHECK CONNECTOR
00D-d (SECTION 00D-d)

@2 : WITH ADVANCED KEYLESS SYSTEM
@3 : WITHOUT DSC &5 : MZR-CD (RF Turbo)
@4 : WITH DSC

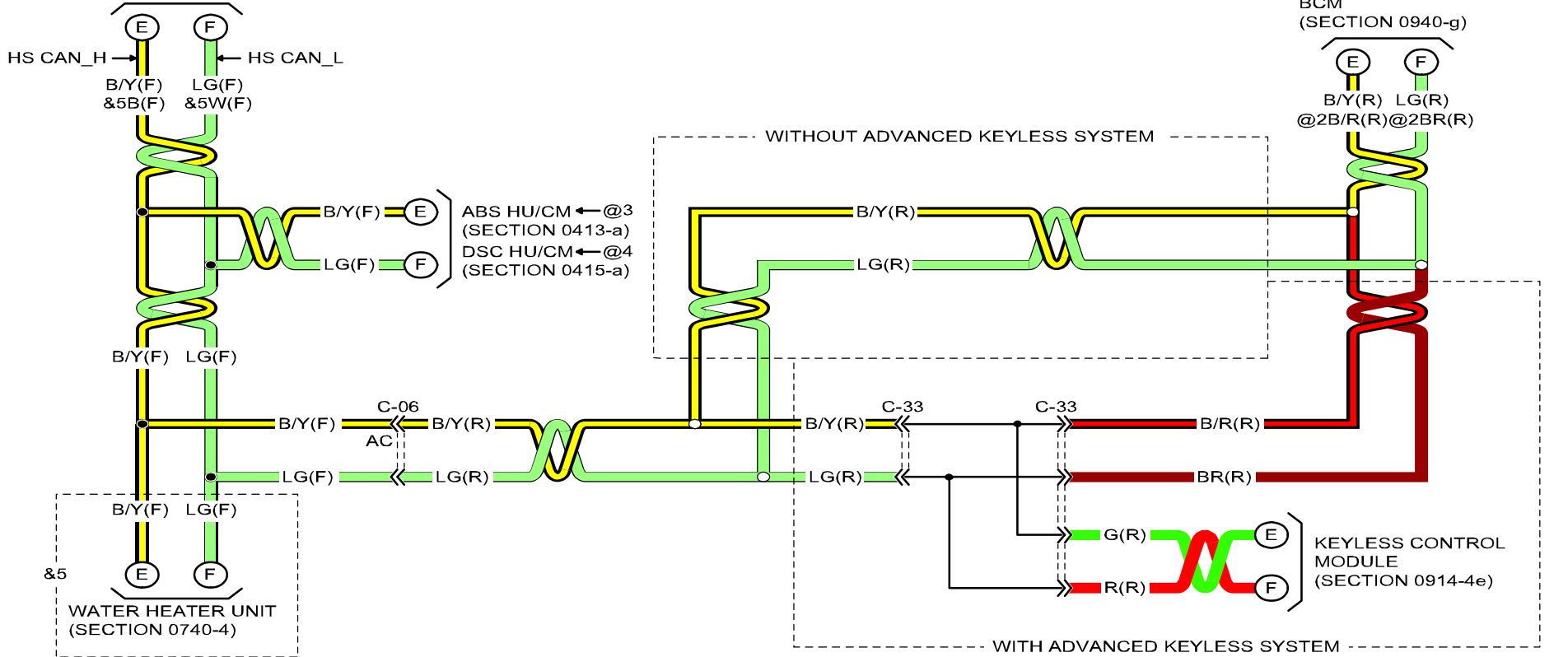

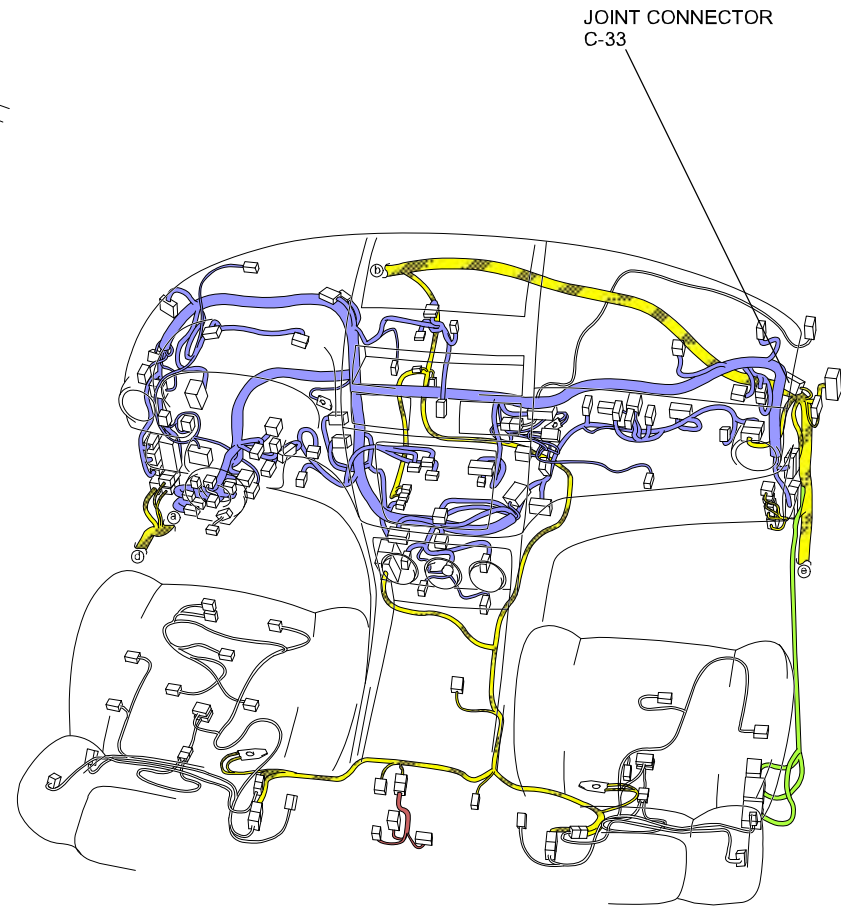
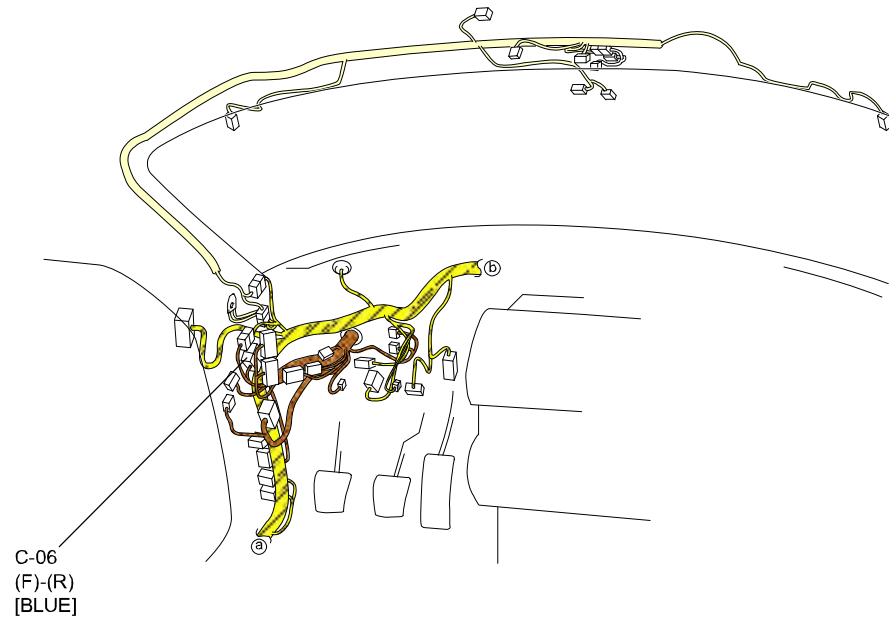

-  : FRONT HARNESS
-  : REAR HARNESS
-  : REAR NO.5 HARNESS
-  : INSTRUMENT PANEL HARNESS
-  : FLOOR HARNESS
-  : INTERIOR LIGHT NO.2 HARNESS

DATA LINK CONNECTOR

00D-e

C-06 FRONT HARNESS-REAR HARNESS

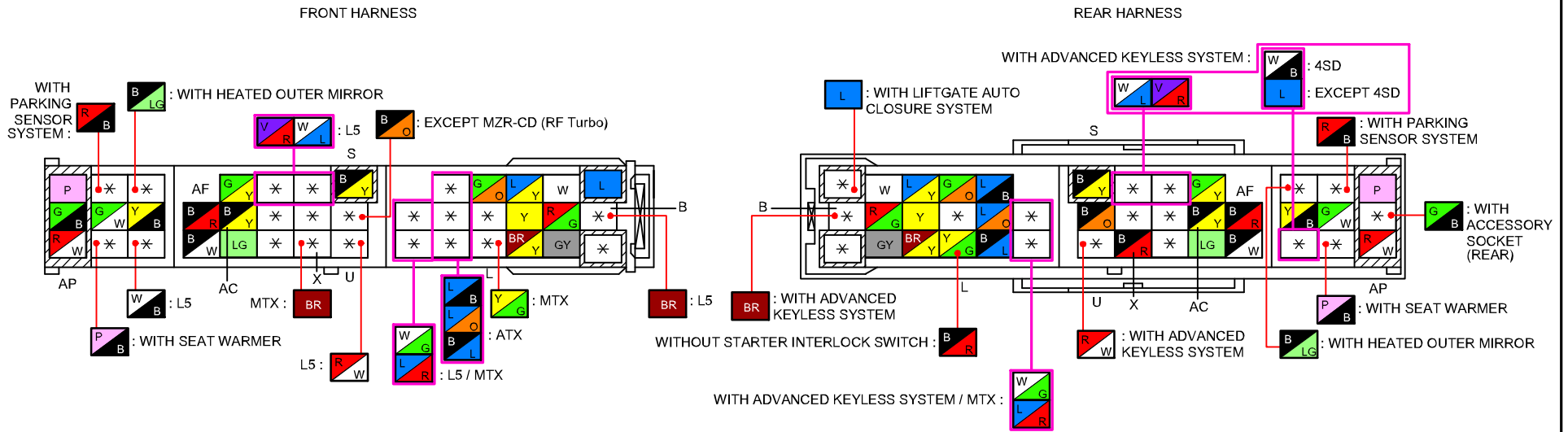

C-33 JOINT CONNECTOR

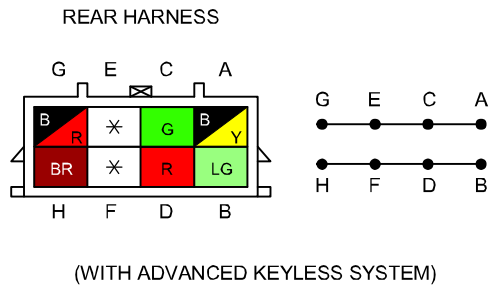

COOLING SYSTEM (WITH TWO COOLING FAN RELAYS / EXCEPT MZR-CD (RF Turbo))

0112-1a

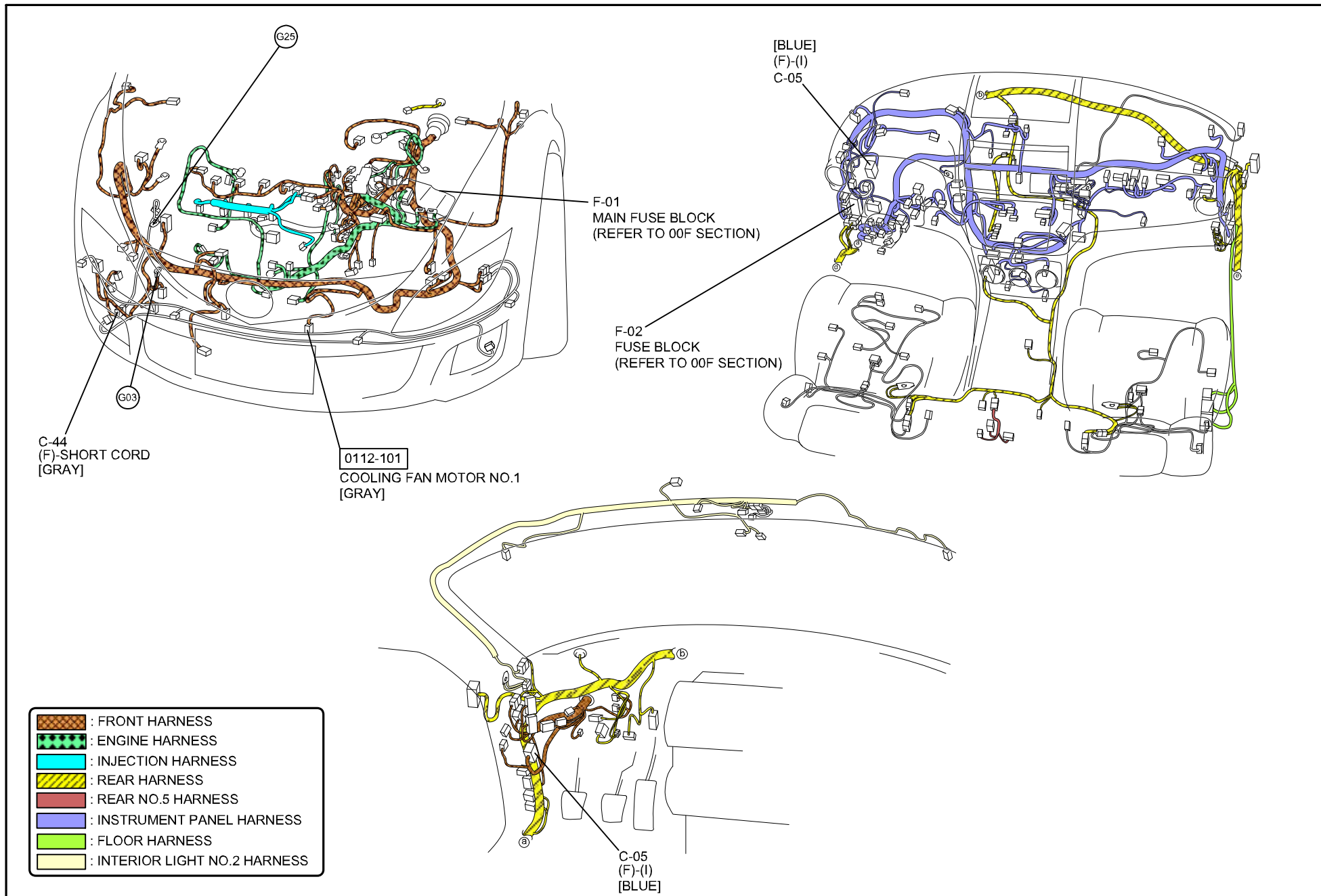

COOLING SYSTEM (WITH TWO COOLING FAN RELAYS / EXCEPT MZR-CD (RF Turbo))

0112-1b

{ } : NAME INDICATED ON FUSE BOX COVER

0112-1a

F-01 MAIN FUSE BLOCK

(SECTION 0112-1a)

a

AD FAN 30A

B/W(F)

B/R(F)

IGNITION SWITCH (IG1)
(SECTION 0112-1a)

4

COOLING FAN MOTOR NO.2

0112-102

0112-102

L(F)

B(F)

W/R(F)

7

PCM
(SECTION 0140-k)

B(F)

C-44

G03

G25



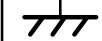

COOLING FAN RELAY NO.2
{AD FAN RELAY}

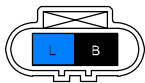

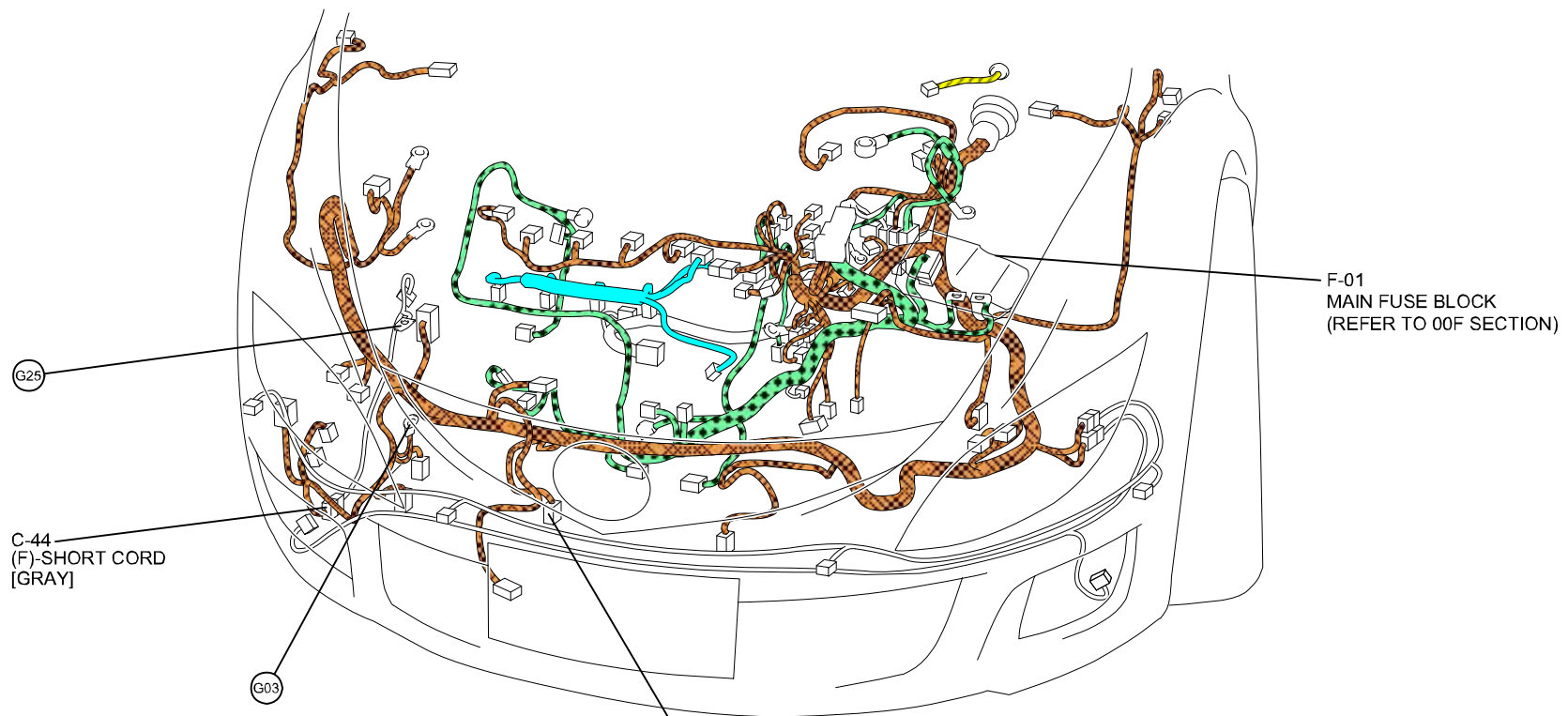
0112-102
COOLING FAN MOTOR NO.2





-  : FRONT HARNESS
-  : ENGINE HARNESS
-  : INJECTION HARNESS
-  : REAR HARNESS

0112-102
COOLING FAN MOTOR NO.2
[GRAY]

C-44
FRONT HARNESS-SHORT CORD

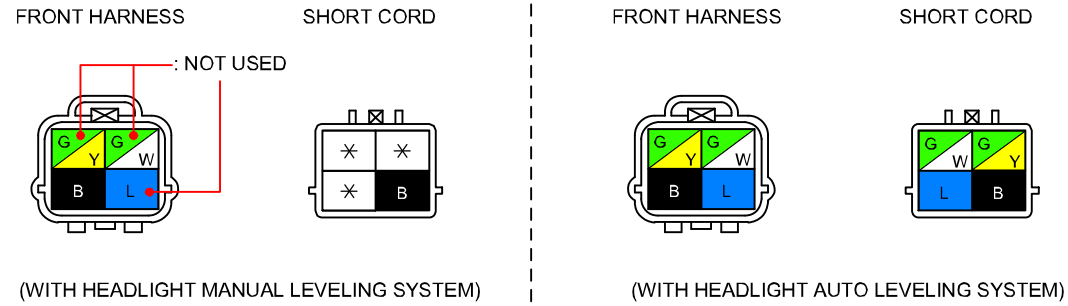

COOLING SYSTEM (WITH FOUR COOLING FAN RELAYS)

0112-2a

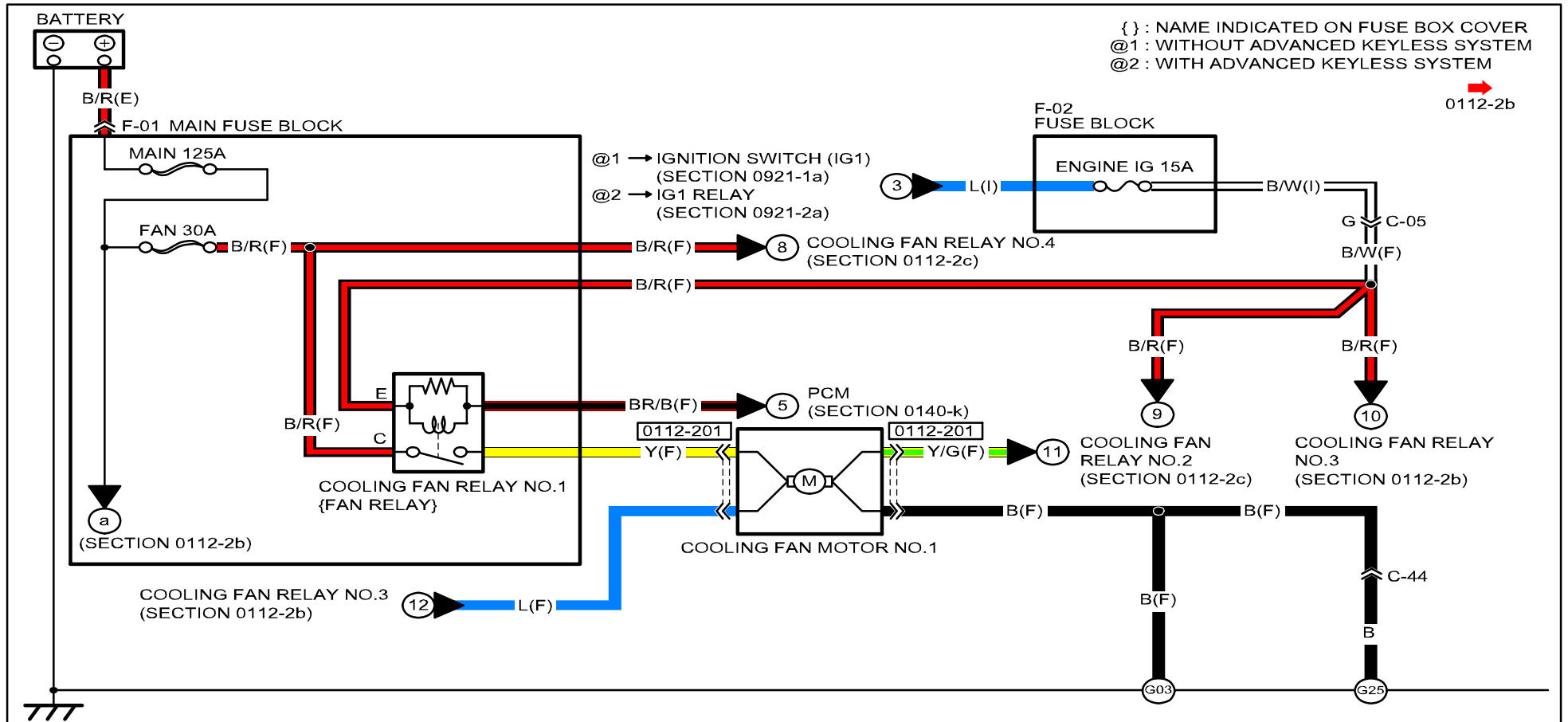

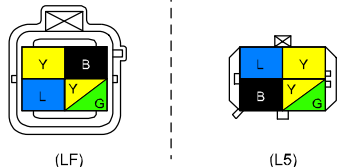
<p>0112-201 COOLING FAN MOTOR NO.1</p>  <p>(LF) (L5)</p>					

COOLING SYSTEM (WITH FOUR COOLING FAN RELAYS)

0112-2a

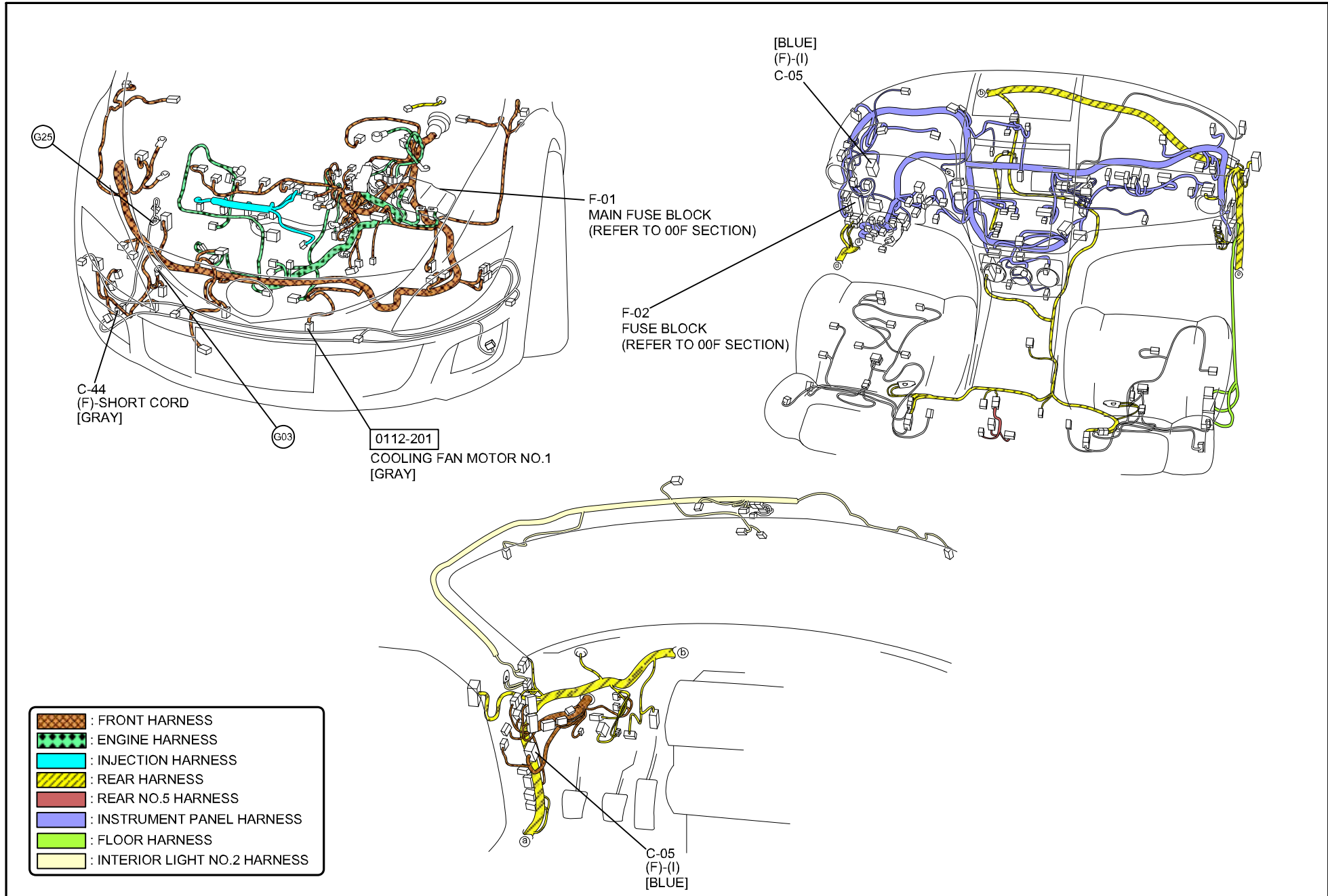

COOLING SYSTEM (WITH FOUR COOLING FAN RELAYS)

0112-2b

0112-2a

{ } : NAME INDICATED ON FUSE BOX COVER
 @1 : WITHOUT ADVANCED KEYLESS SYSTEM
 @2 : WITH ADVANCED KEYLESS SYSTEM

0112-2c

F-01 MAIN FUSE BLOCK

(SECTION 0112-2a)

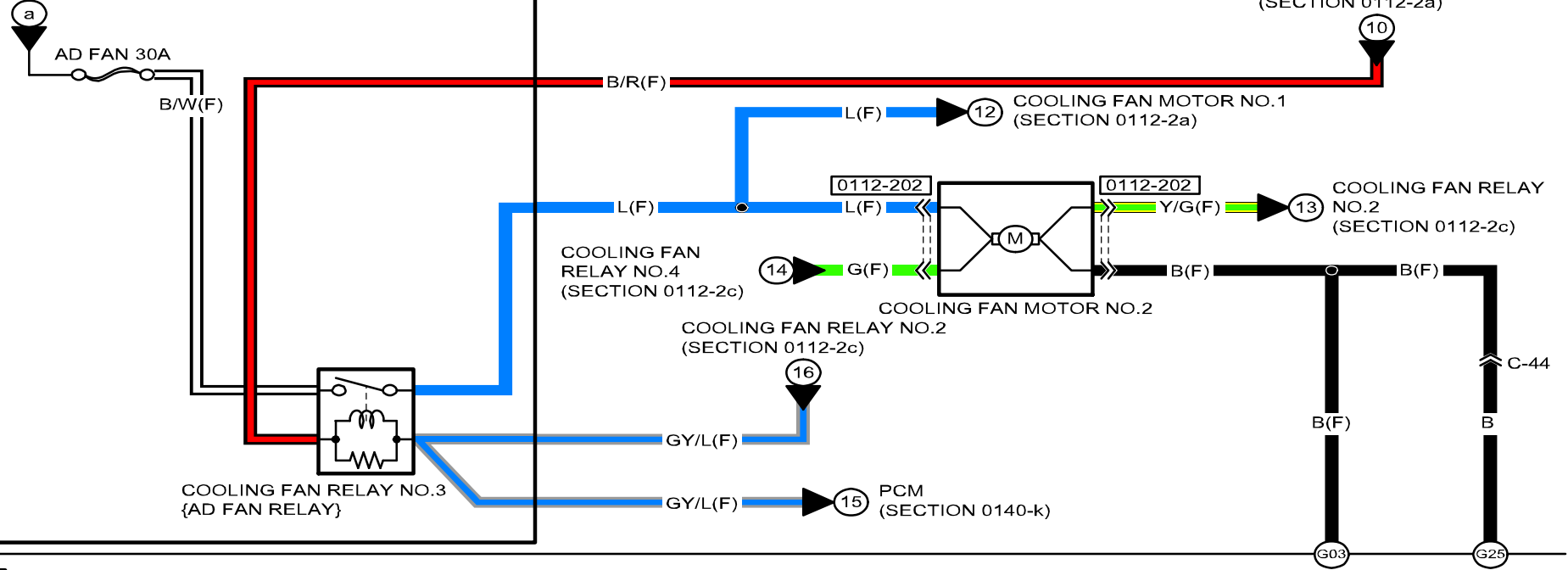

@1 → IGNITION SWITCH (IG1)
 @2 → IG1 RELAY (SECTION 0112-2a)

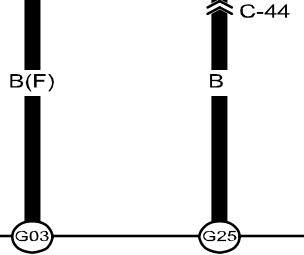

0112-202
 COOLING FAN MOTOR NO.2

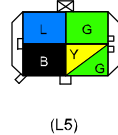
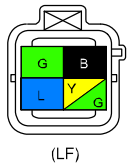

COOLING SYSTEM (WITH FOUR COOLING FAN RELAYS)

0112-2b

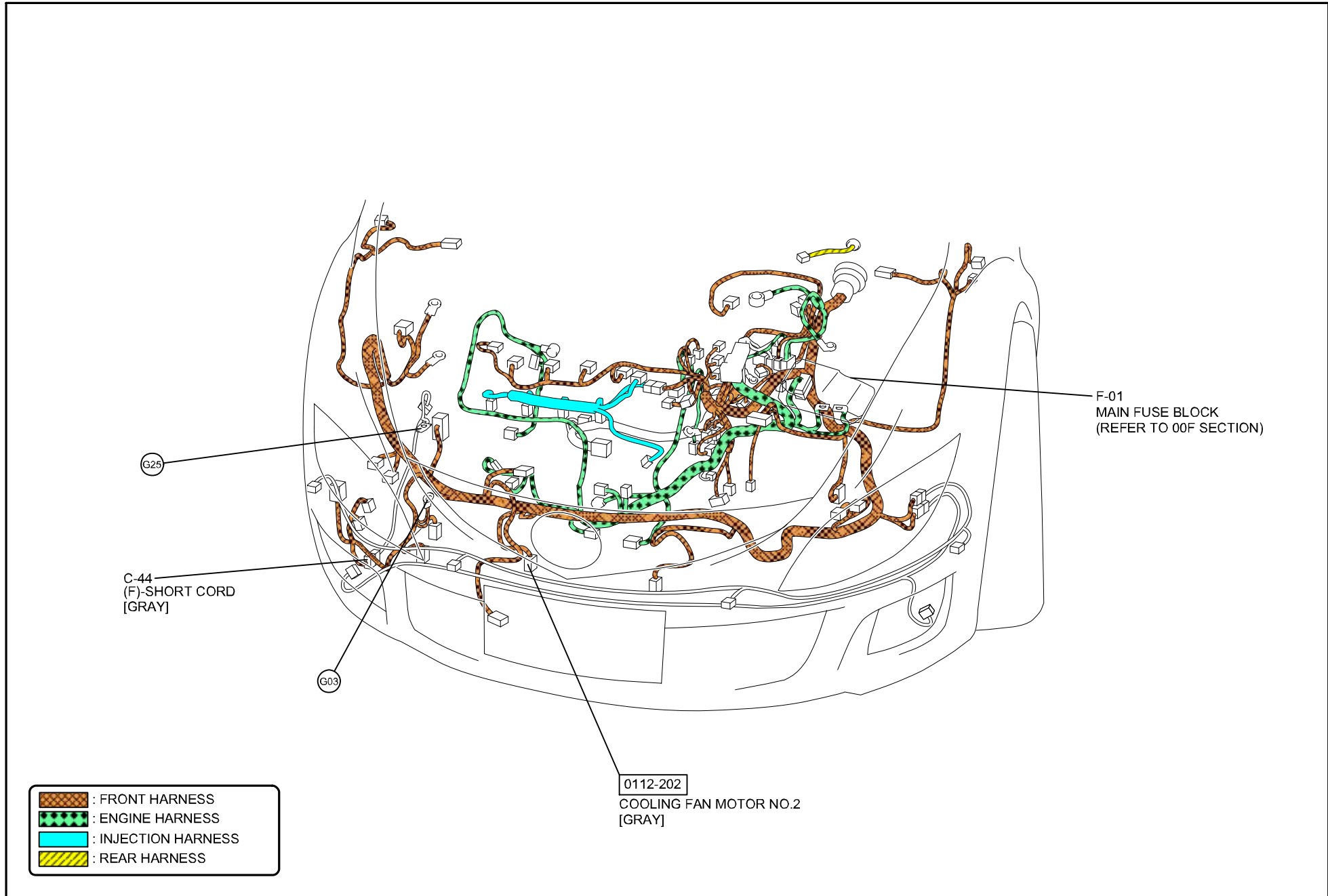

C-44
FRONT HARNESS-SHORT CORD

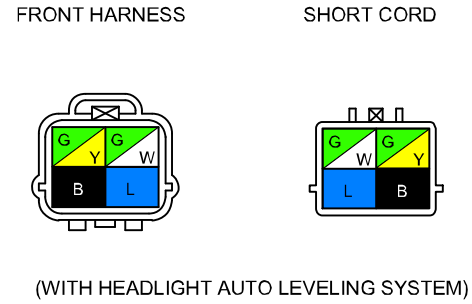
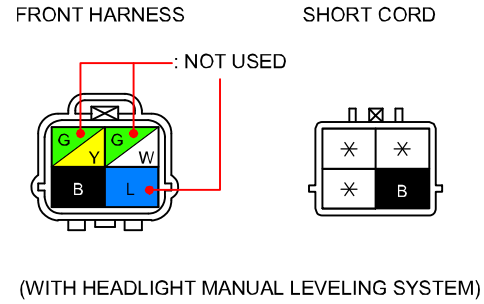

COOLING SYSTEM (WITH FOUR COOLING FAN RELAYS)

0112-2c

0112-2b

{ } : NAME INDICATED ON FUSE BOX COVER
 < > : NOT USED
 @1 : WITHOUT ADVANCED KEYLESS SYSTEM
 @2 : WITH ADVANCED KEYLESS SYSTEM

@1 → IGNITION SWITCH (IG1)
 @2 → IG1 RELAY (SECTION 0112-2a)
 MAIN FUSE BLOCK (SECTION 0112-2a)



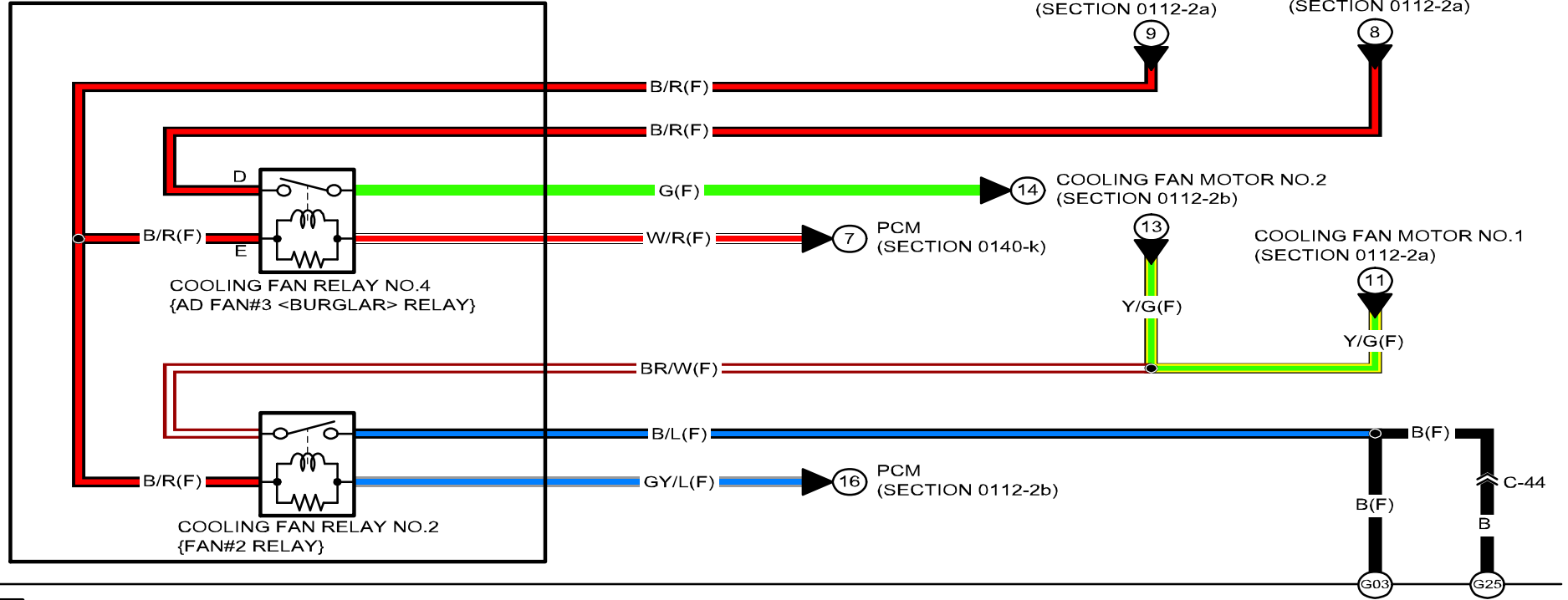

F-01 MAIN FUSE BLOCK

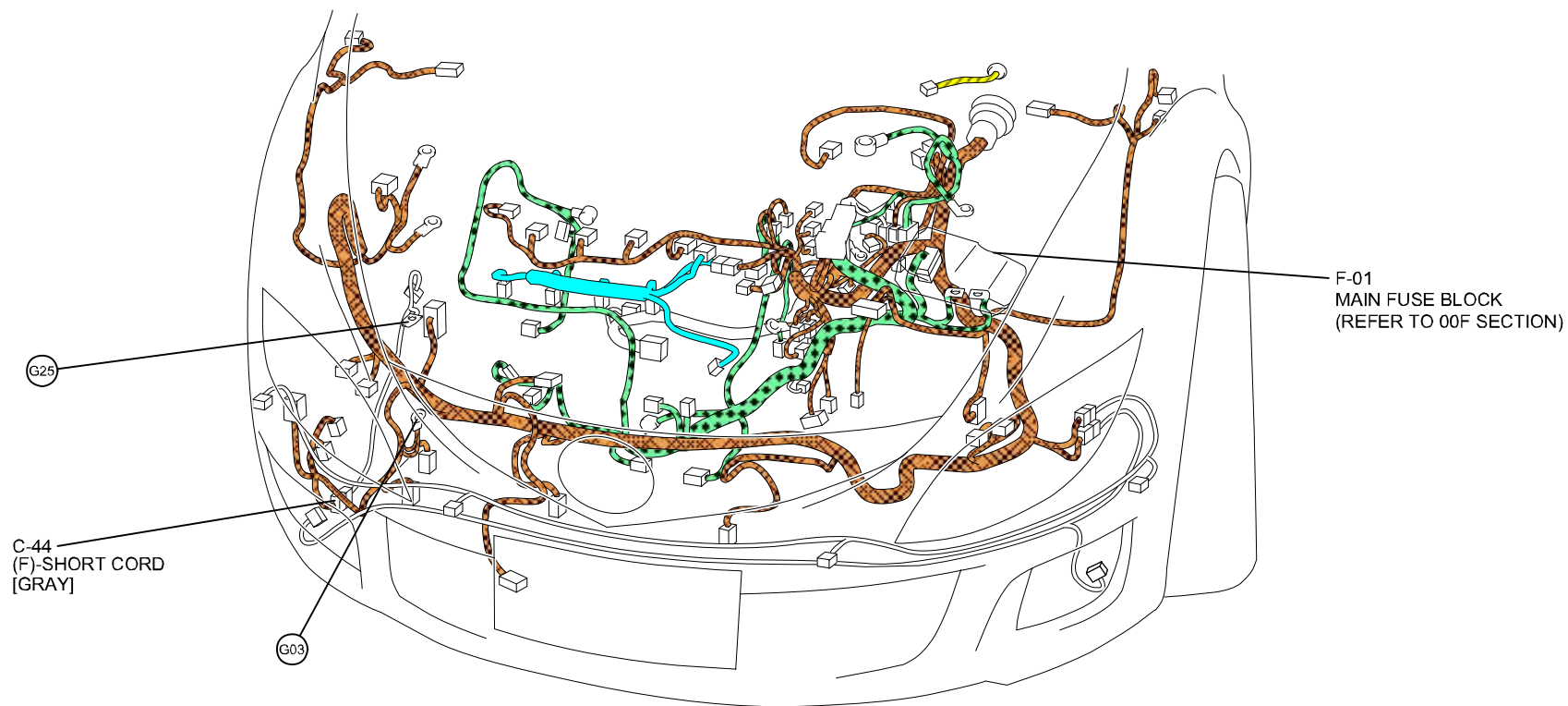

COOLING SYSTEM (WITH FOUR COOLING FAN RELAYS)

0112-2c



-  : FRONT HARNESS
-  : ENGINE HARNESS
-  : INJECTION HARNESS
-  : REAR HARNESS

C-44
FRONT HARNESS-SHORT CORD

FRONT HARNESS

SHORT CORD

FRONT HARNESS

SHORT CORD

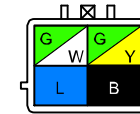
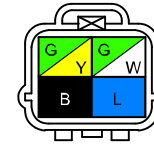
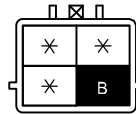
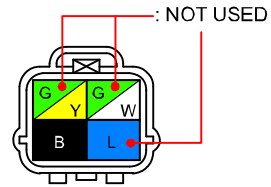

(WITH HEADLIGHT MANUAL LEVELING SYSTEM)

(WITH HEADLIGHT AUTO LEVELING SYSTEM)

COOLING SYSTEM (WITH THREE COOLING FAN RELAYS)

0112-3a

0112-3b

{ } : NAME INDICATED ON FUSE BOX COVER

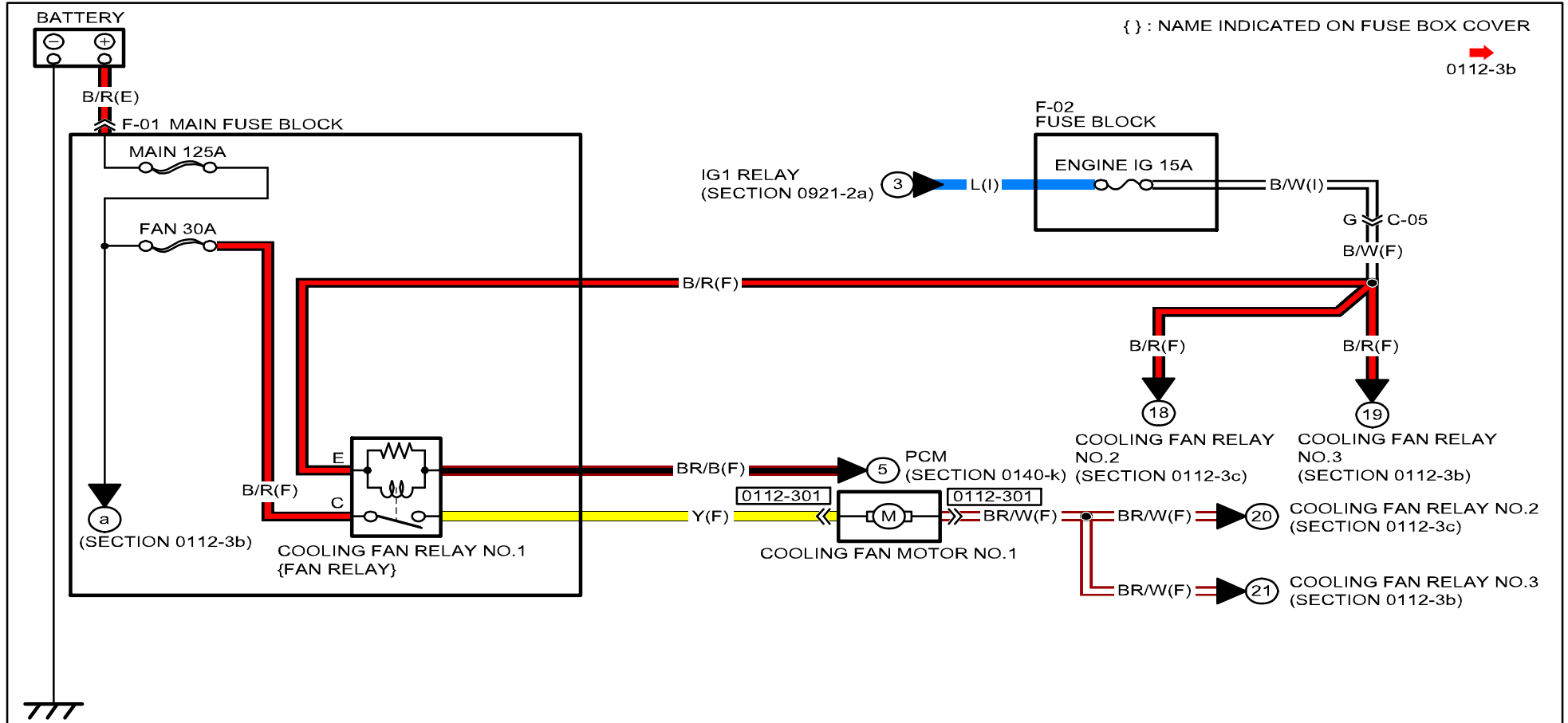

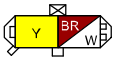





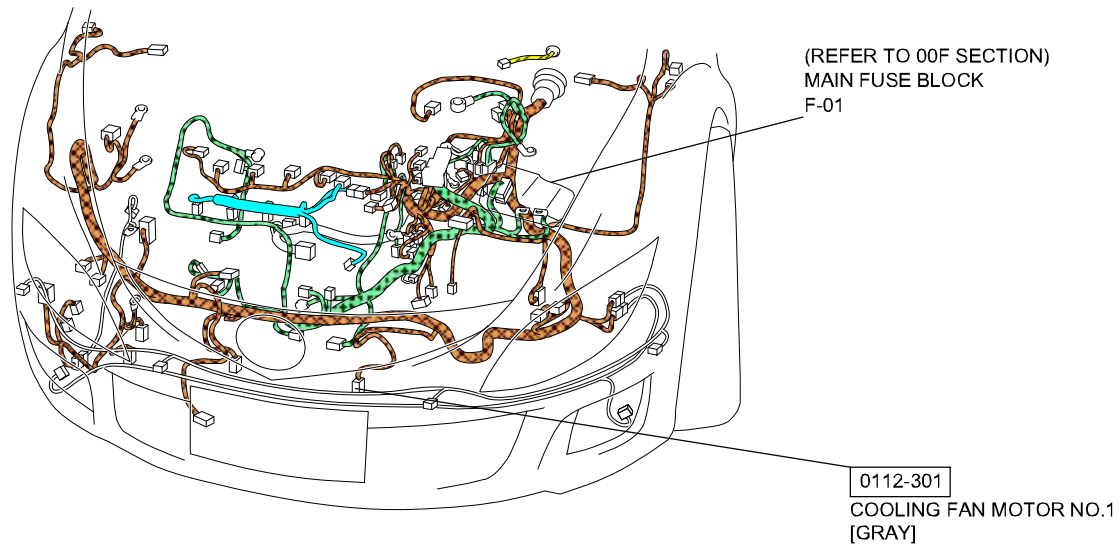
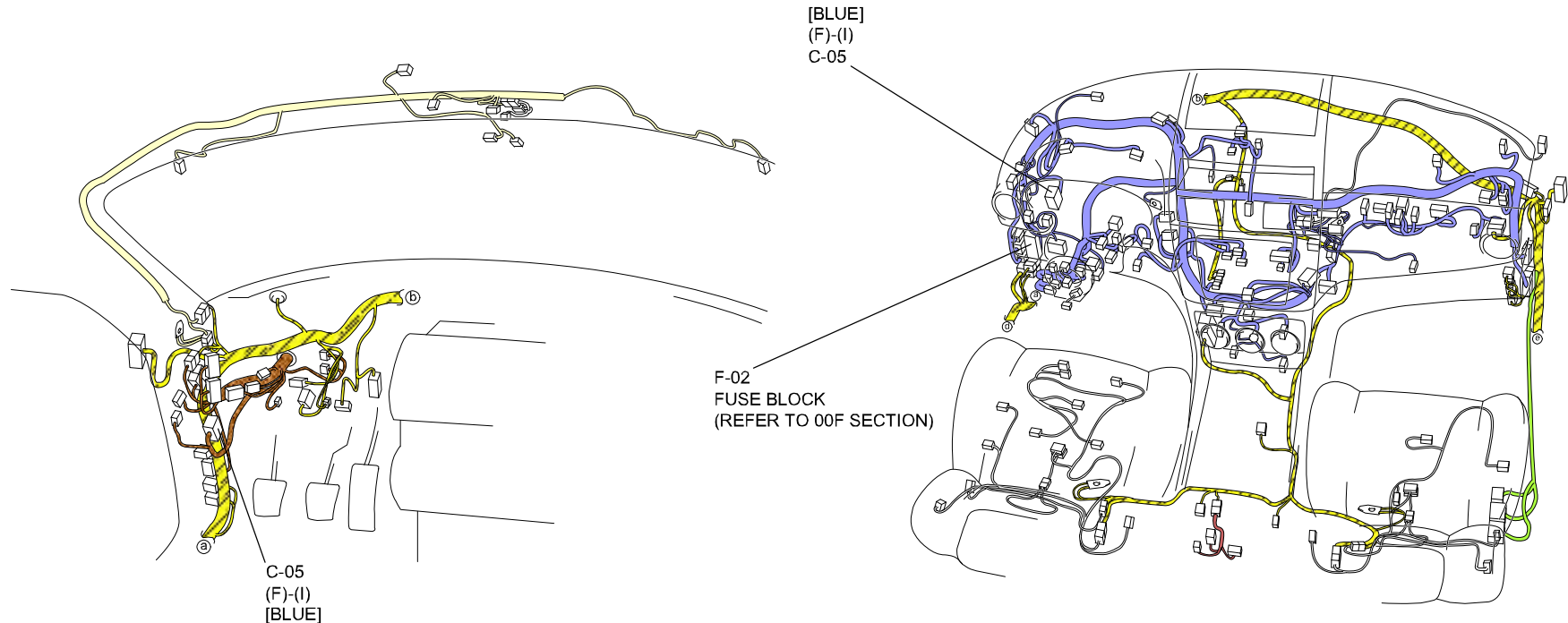

<p>0112-301 COOLING FAN MOTOR NO.1</p> 					

COOLING SYSTEM (WITH THREE COOLING FAN RELAYS)

0112-3a



-  : FRONT HARNESS
-  : ENGINE HARNESS
-  : INJECTION HARNESS
-  : REAR HARNESS
-  : REAR NO.5 HARNESS
-  : INSTRUMENT PANEL HARNESS
-  : FLOOR HARNESS
-  : INTERIOR LIGHT NO.2 HARNESS

COOLING SYSTEM (WITH THREE COOLING FAN RELAYS)

0112-3a

C-05

FRONT HARNESS-INSTRUMENT PANEL HARNESS

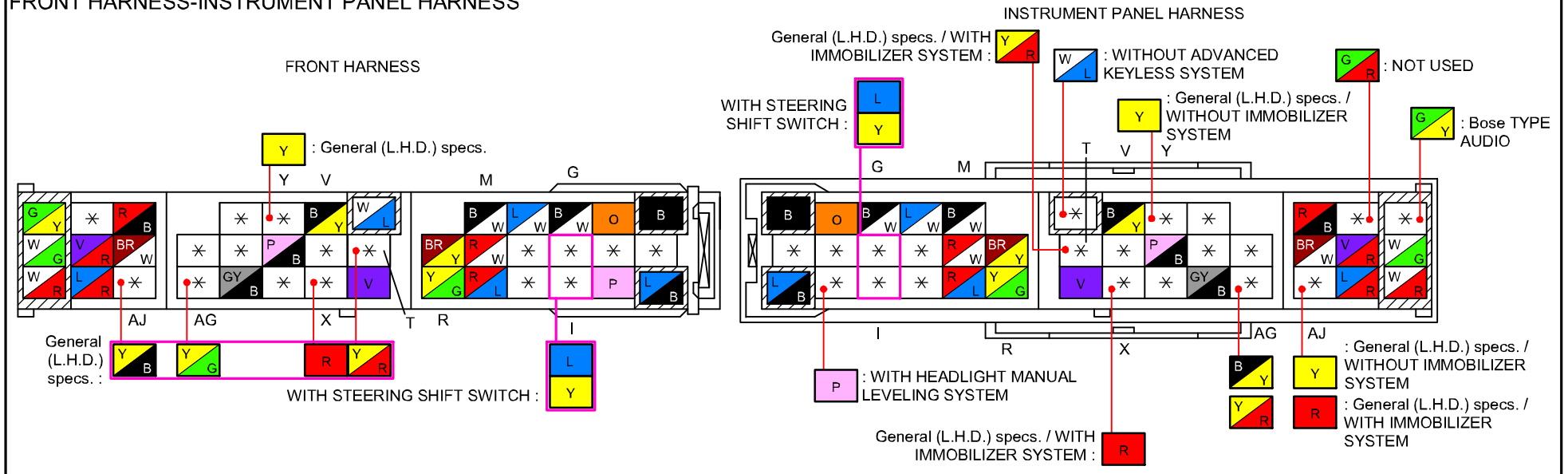

COOLING SYSTEM (WITH THREE COOLING FAN RELAYS)

0112-3b

{ } : NAME INDICATED ON FUSE BOX COVER

0112-3a

0112-3c

F-01 MAIN FUSE BLOCK

(SECTION 0112-3a)



B/W(F)

COOLING FAN RELAY NO.3
{AD FAN RELAY}

COOLING FAN MOTOR NO.1
(SECTION 0112-3a)

IG1 RELAY
(SECTION 0112-3a)

(21)

(19)

B/R(F)

BR/W(F)

0112-302

L(F)

(M)

0112-302

B(F)

COOLING FAN MOTOR NO.2

(22)

COOLING FAN RELAY NO.2
(SECTION 0112-3c)

GY/L(F)

(15)

PCM
(SECTION 0140-k)

GY/L(F)

B(F)

B(F)

B(F)

C-44

B

G03

G25

0112-302
COOLING FAN MOTOR NO.2

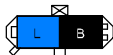

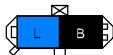
<p>0112-302 COOLING FAN MOTOR NO.2</p> 					

COOLING SYSTEM (WITH THREE COOLING FAN RELAYS)

0112-3b

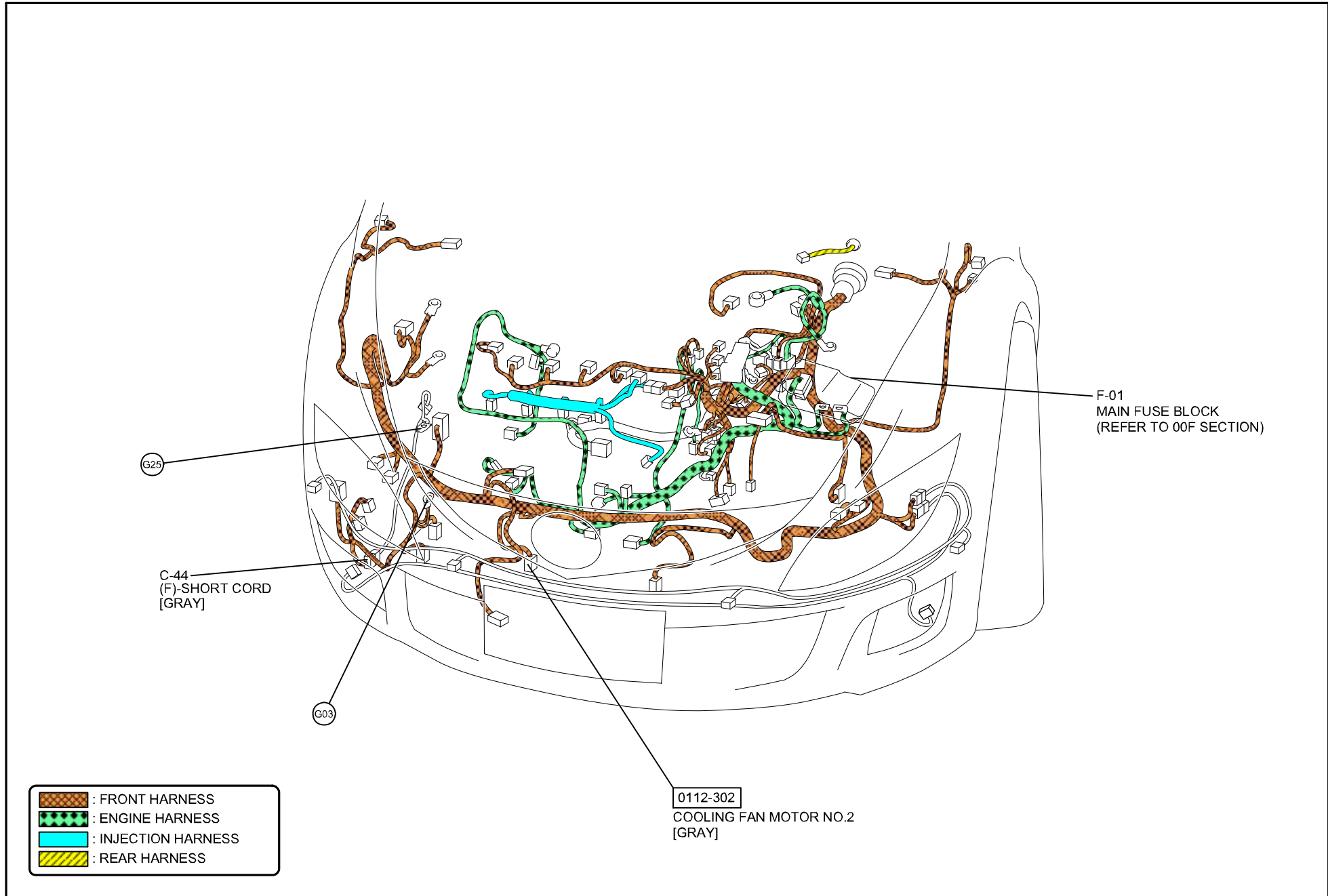

C-44

FRONT HARNESS-SHORT CORD

FRONT HARNESS

SHORT CORD

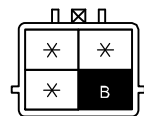
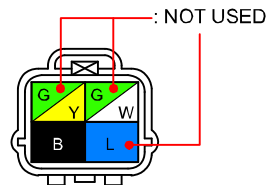

(WITH HEADLIGHT MANUAL LEVELING SYSTEM)

FRONT HARNESS

SHORT CORD

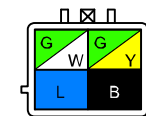
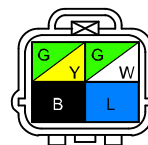

(WITH HEADLIGHT AUTO LEVELING SYSTEM)

COOLING SYSTEM (WITH THREE COOLING FAN RELAYS)

0112-3c

{ } : NAME INDICATED ON FUSE BOX COVER

0112-3b

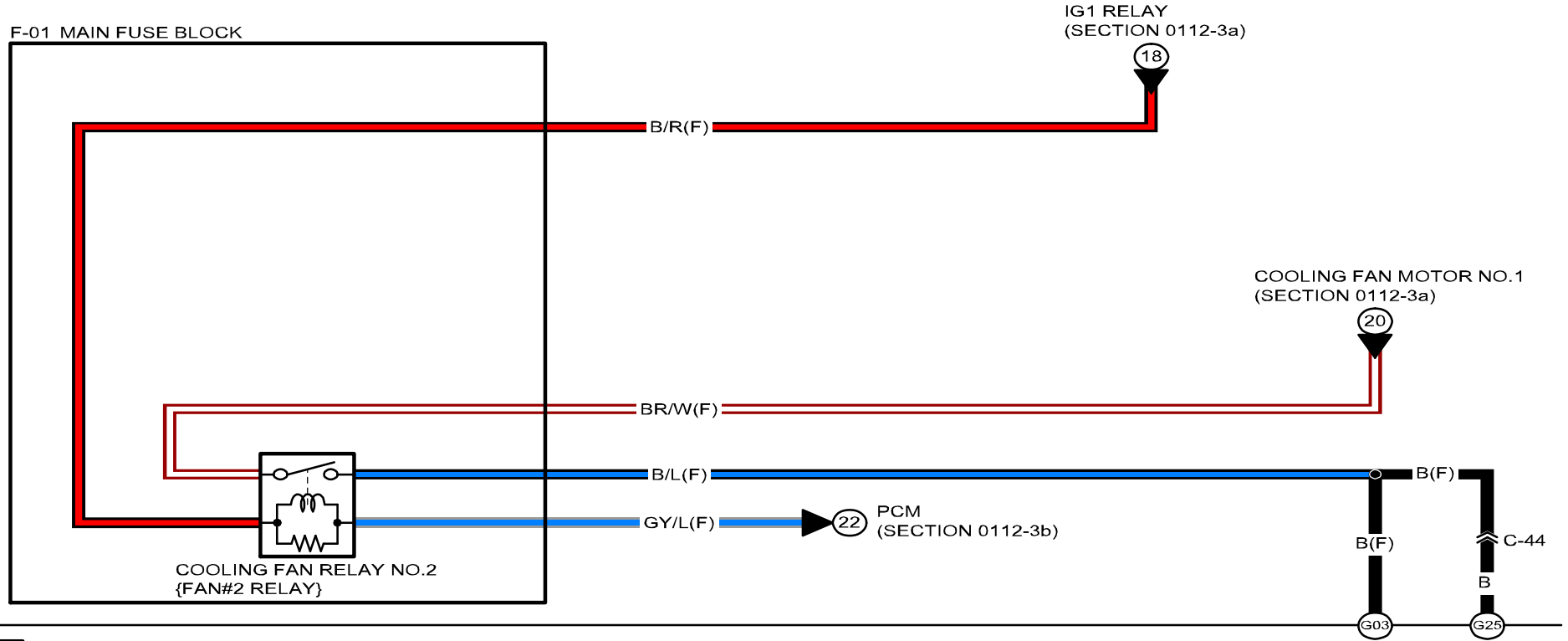



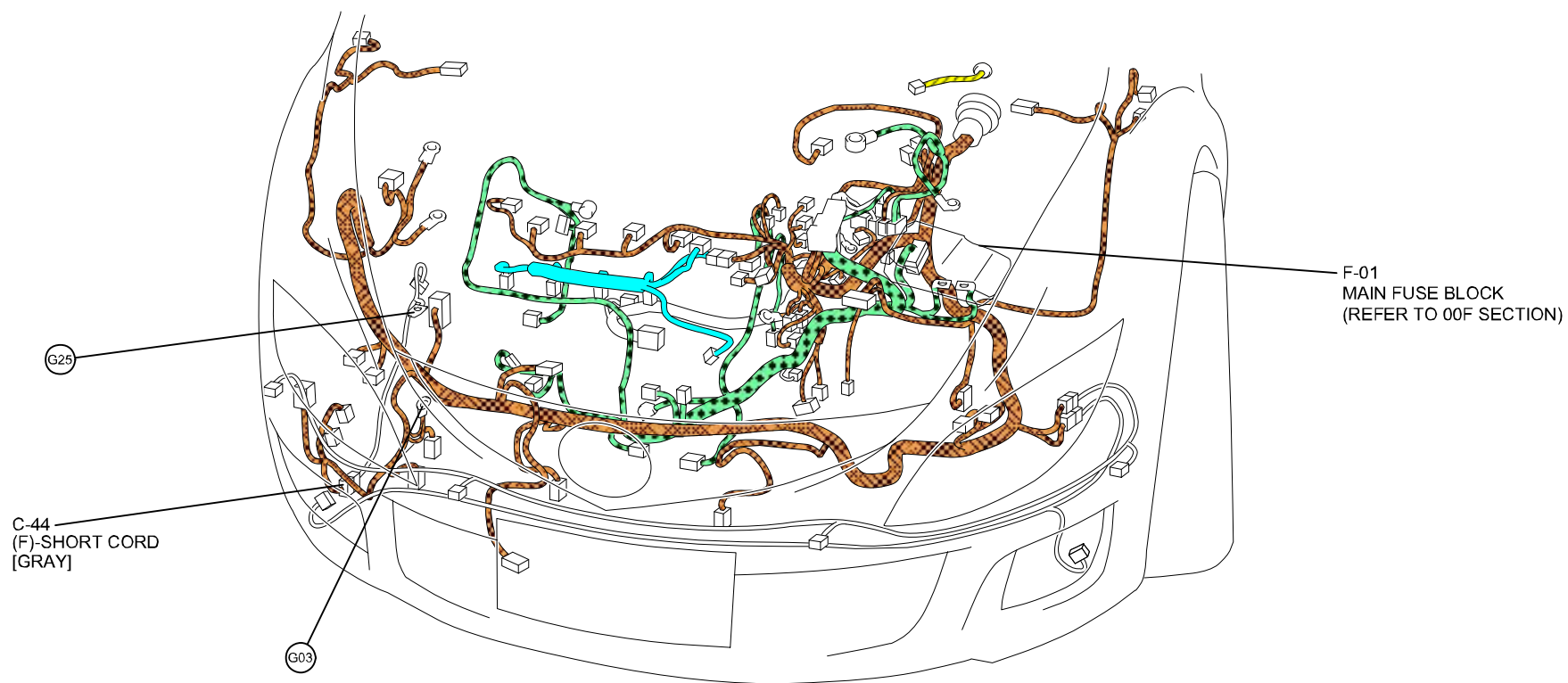

COOLING SYSTEM (WITH THREE COOLING FAN RELAYS)

0112-3c



C-44
(F)-SHORT CORD
[GRAY]

F-01
MAIN FUSE BLOCK
(REFER TO 00F SECTION)

-  : FRONT HARNESS
-  : ENGINE HARNESS
-  : INJECTION HARNESS
-  : REAR HARNESS

C-44
FRONT HARNESS-SHORT CORD

FRONT HARNESS

SHORT CORD

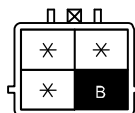
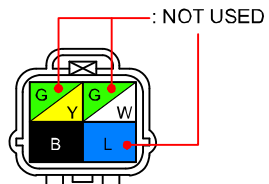

(WITH HEADLIGHT MANUAL LEVELING SYSTEM)

FRONT HARNESS

SHORT CORD

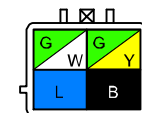
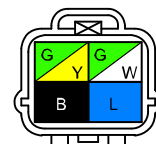

(WITH HEADLIGHT AUTO LEVELING SYSTEM)

COOLING SYSTEM (MZR-CD (RF Turbo))

0112-4a

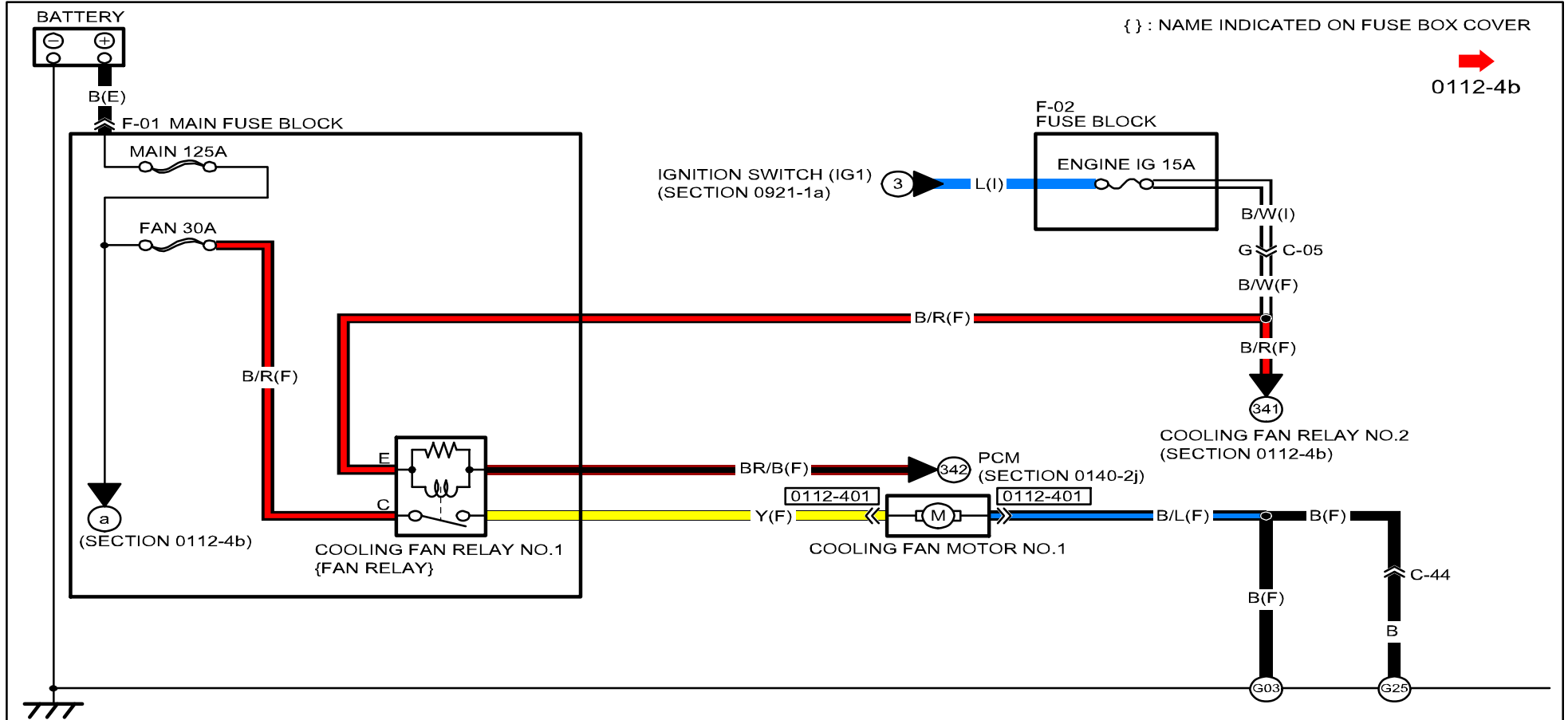

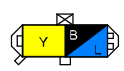
<p>0112-401 COOLING FAN MOTOR NO.1</p> 					

COOLING SYSTEM (MZR-CD (RF Turbo))

0112-4a

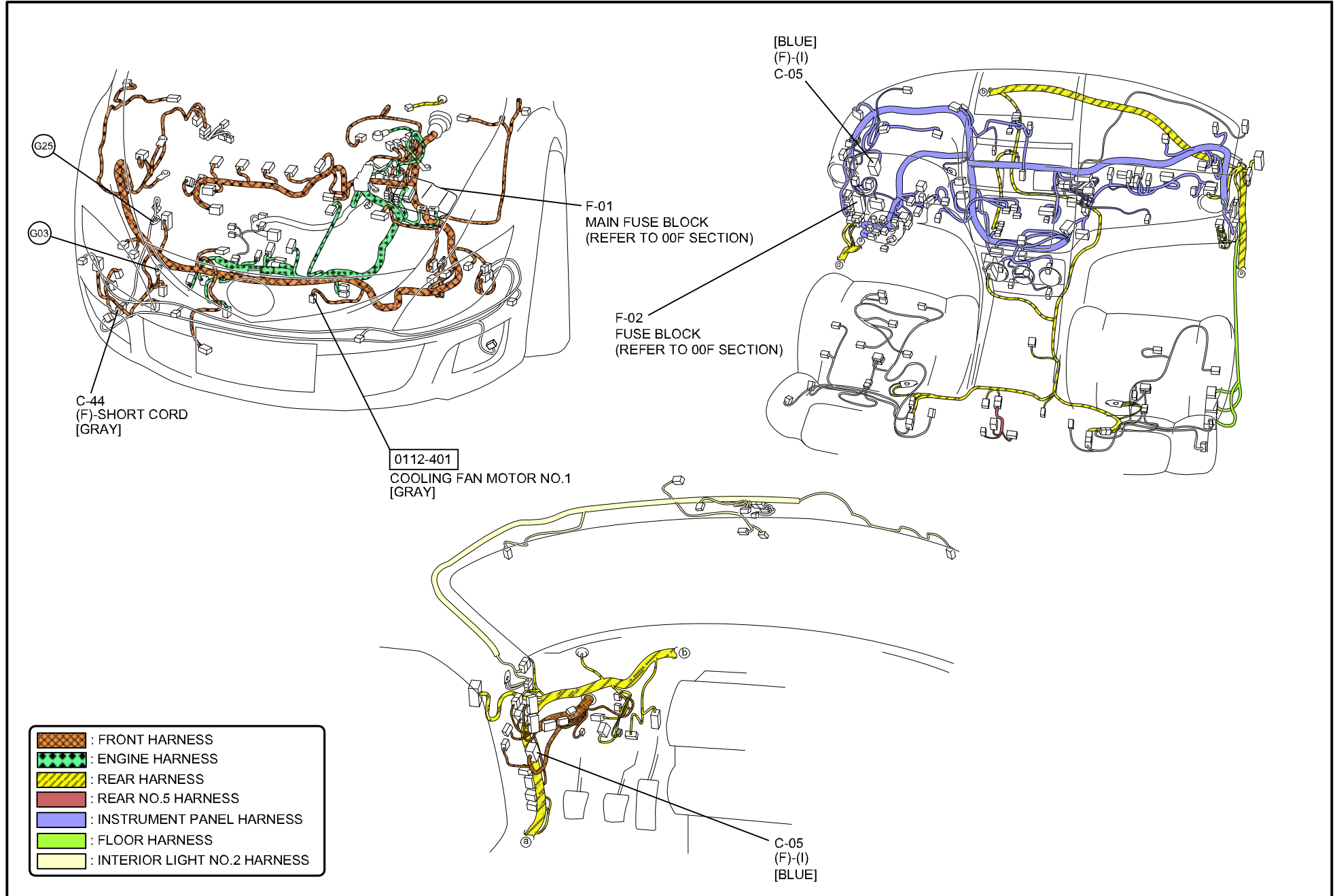

{ } : NAME INDICATED ON FUSE BOX COVER

0112-4a

F-01 MAIN FUSE BLOCK

(SECTION 0112-4a)

a

AD FAN 30A

B/W(F)

B/R(F)

IGNITION SWITCH (IG1)
(SECTION 0112-4a)

341

COOLING FAN MOTOR NO.2

0112-402

0112-402

L(F)

B(F)

W/R(F)

343

PCM
(SECTION 0140-2j)

B(F)

G03

C-44

G25

COOLING FAN RELAY NO.2
{AD FAN RELAY}



0112-402
COOLING FAN MOTOR NO.2

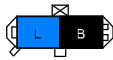

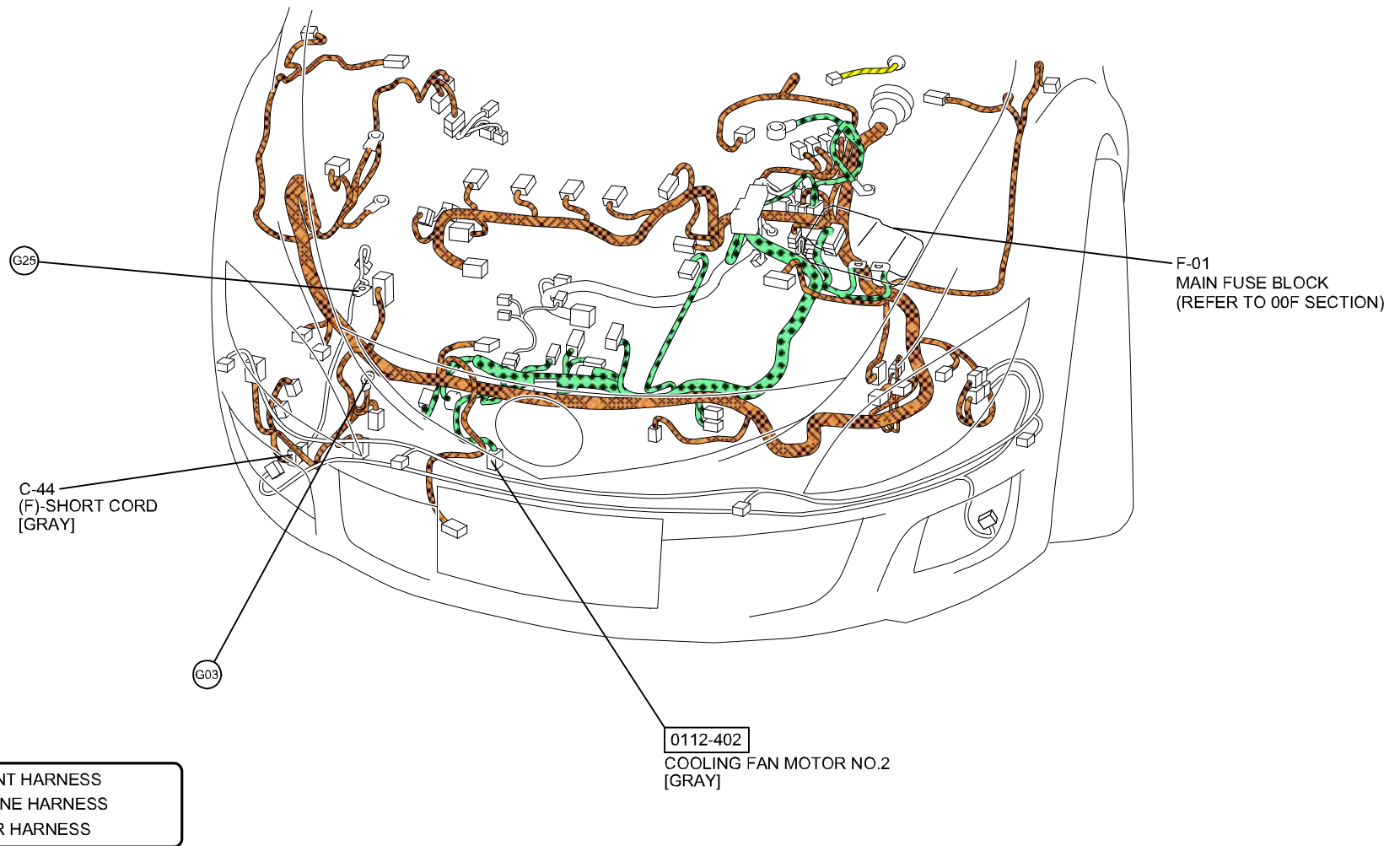

C-44
FRONT HARNESS-SHORT CORD

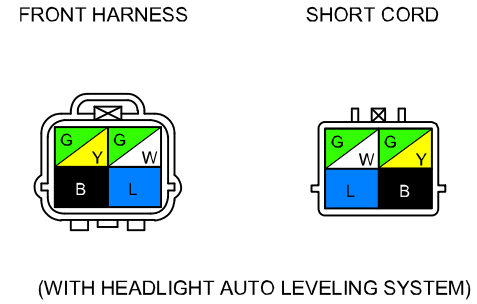
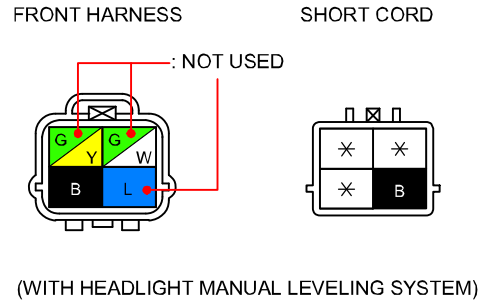

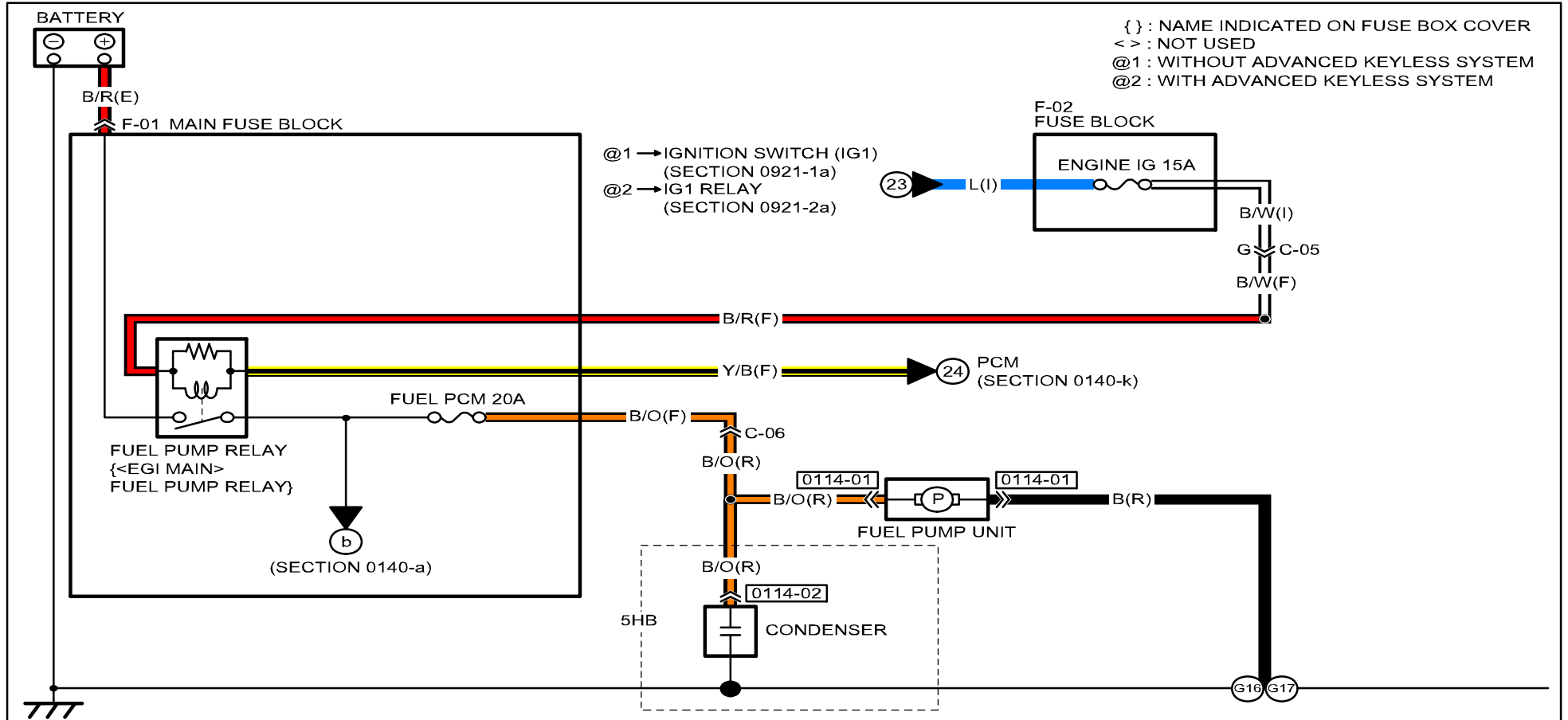

0114-01 FUEL PUMP UNIT / FUEL GAUGE SENDER UNIT 	0114-02 CONDENSER 				

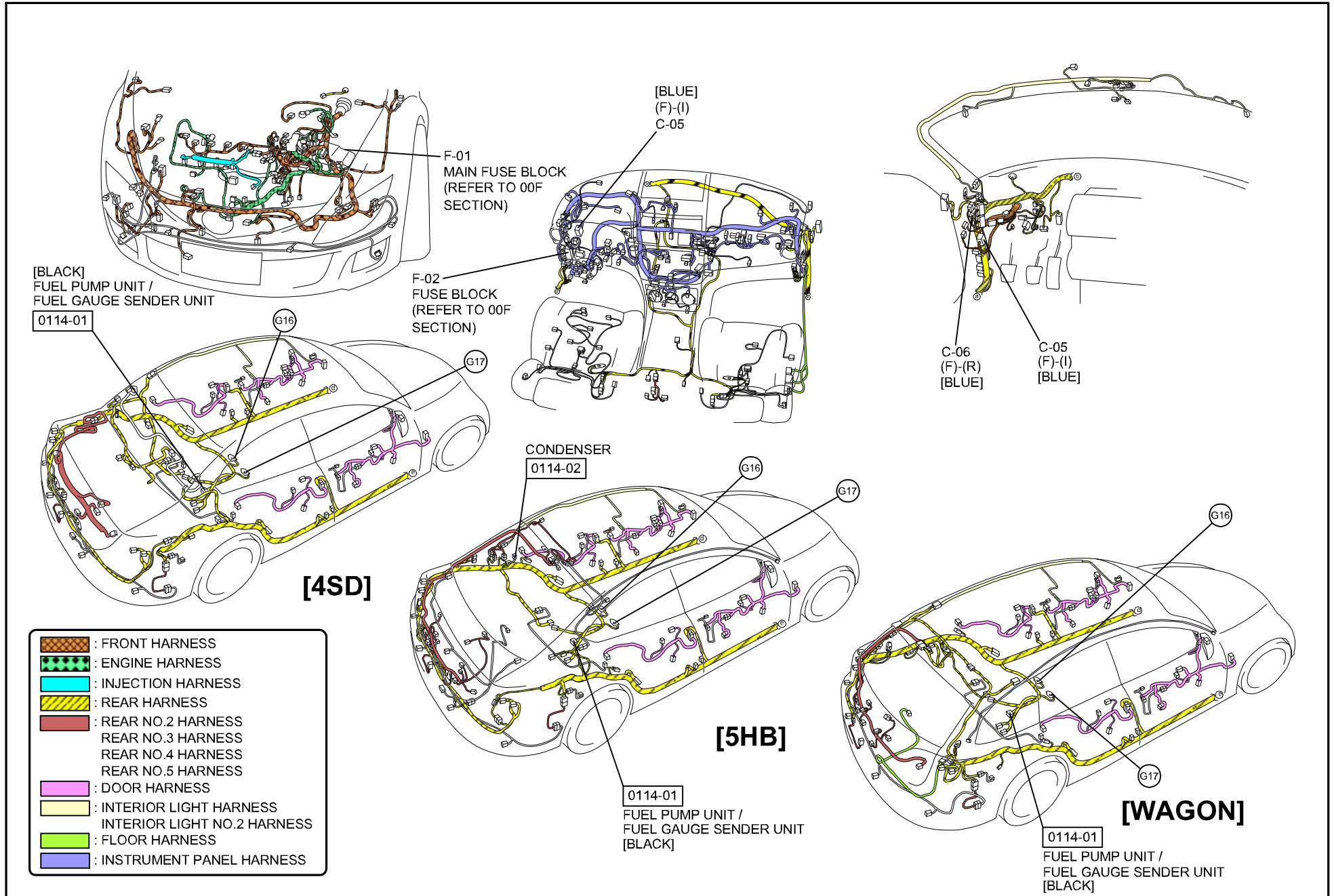

C-05
FRONT HARNESS-INSTRUMENT PANEL HARNESS

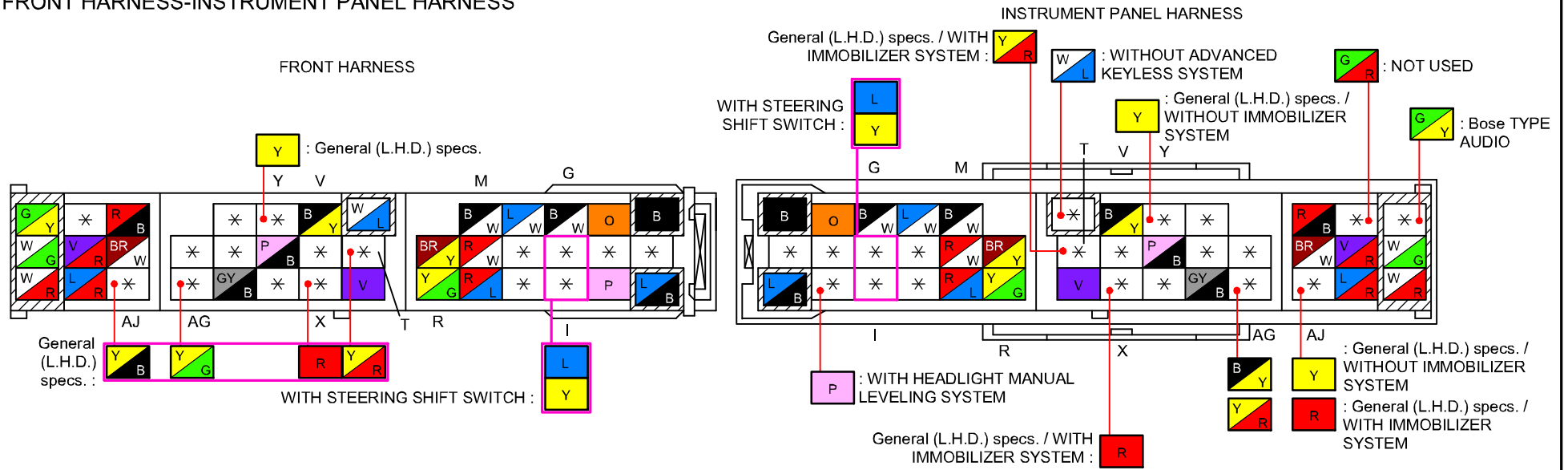

C-06
FRONT HARNESS-REAR HARNESS

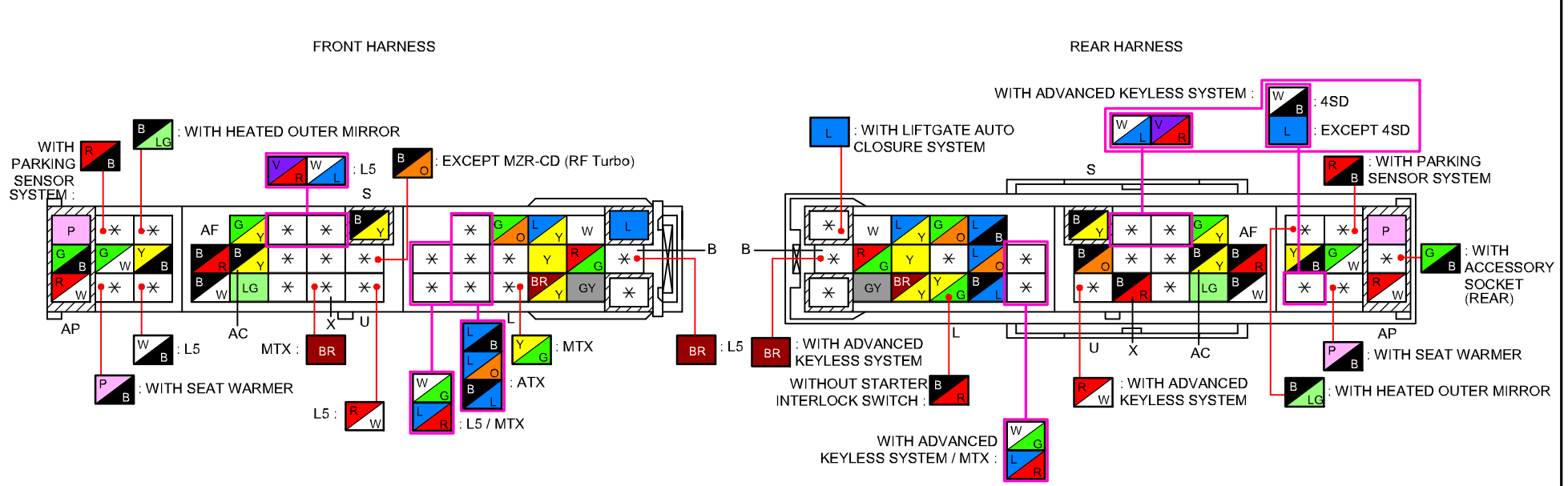



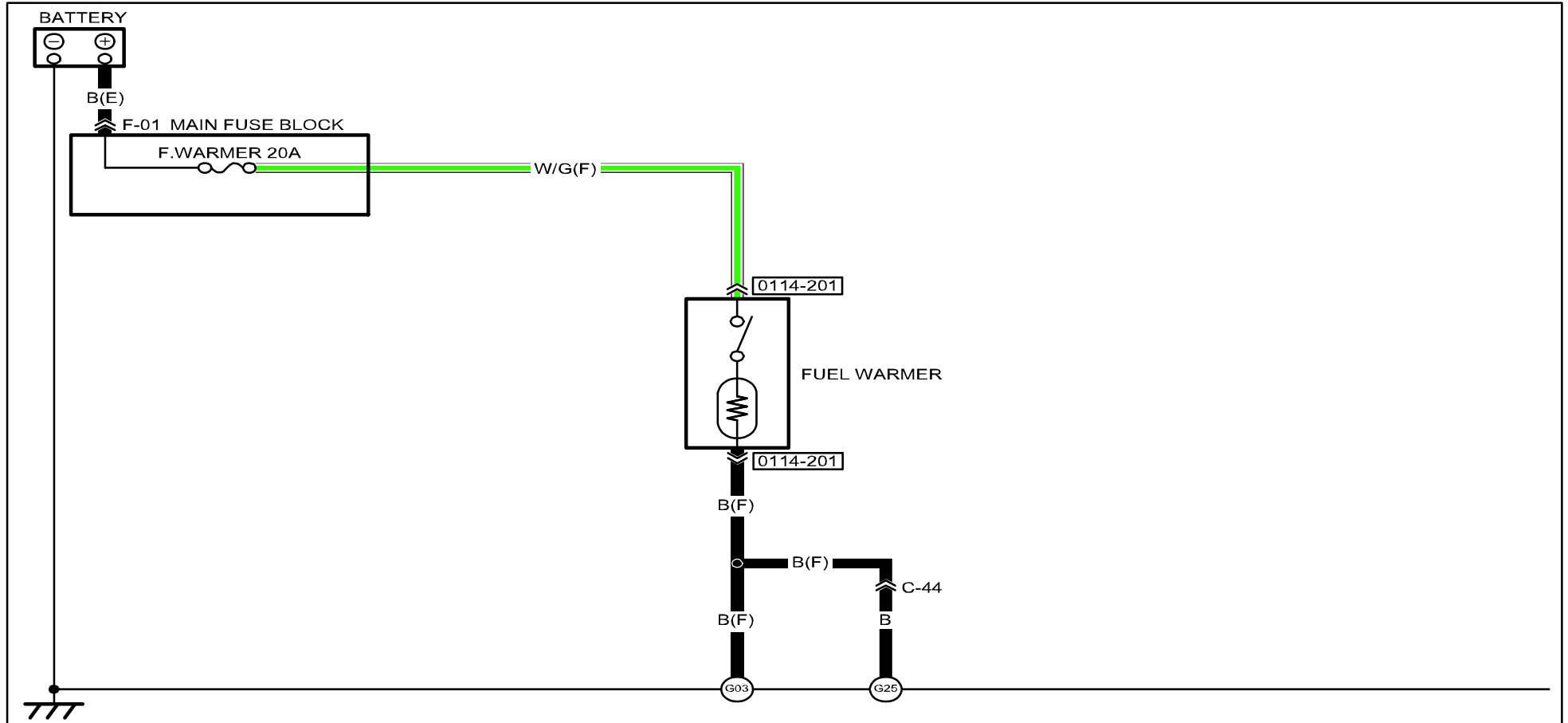

FUEL WARMER

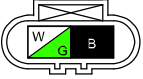
0114-2

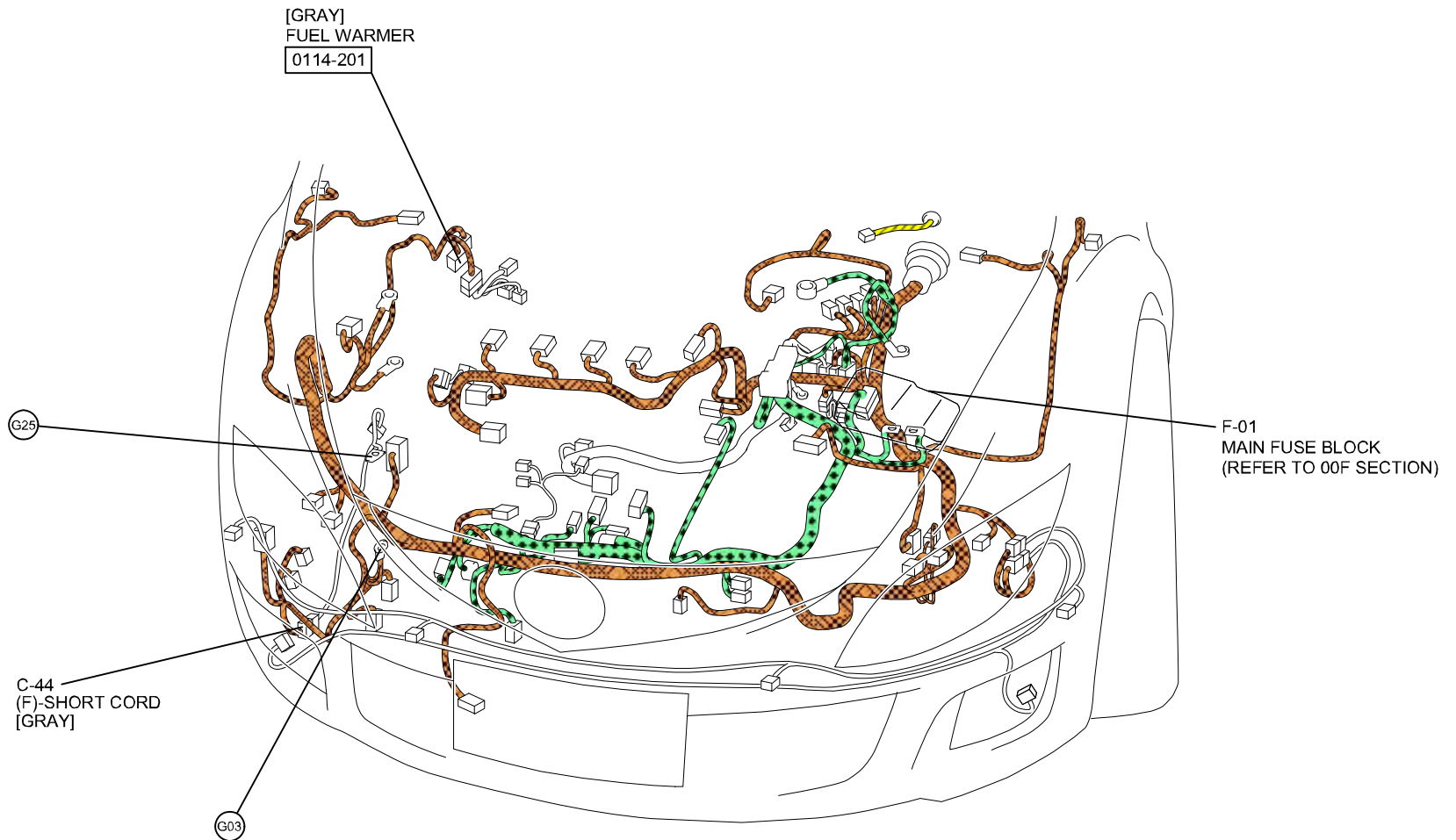

<p>0114-201 FUEL WARMER</p> 						



-  : FRONT HARNESS
-  : ENGINE HARNESS
-  : REAR HARNESS



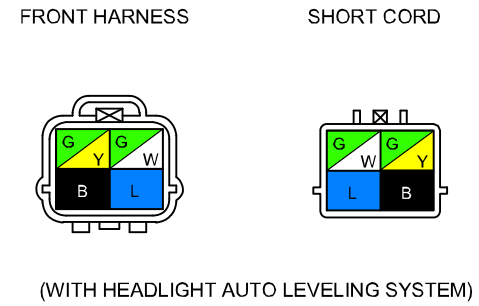
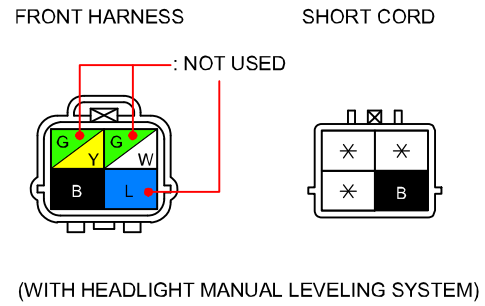

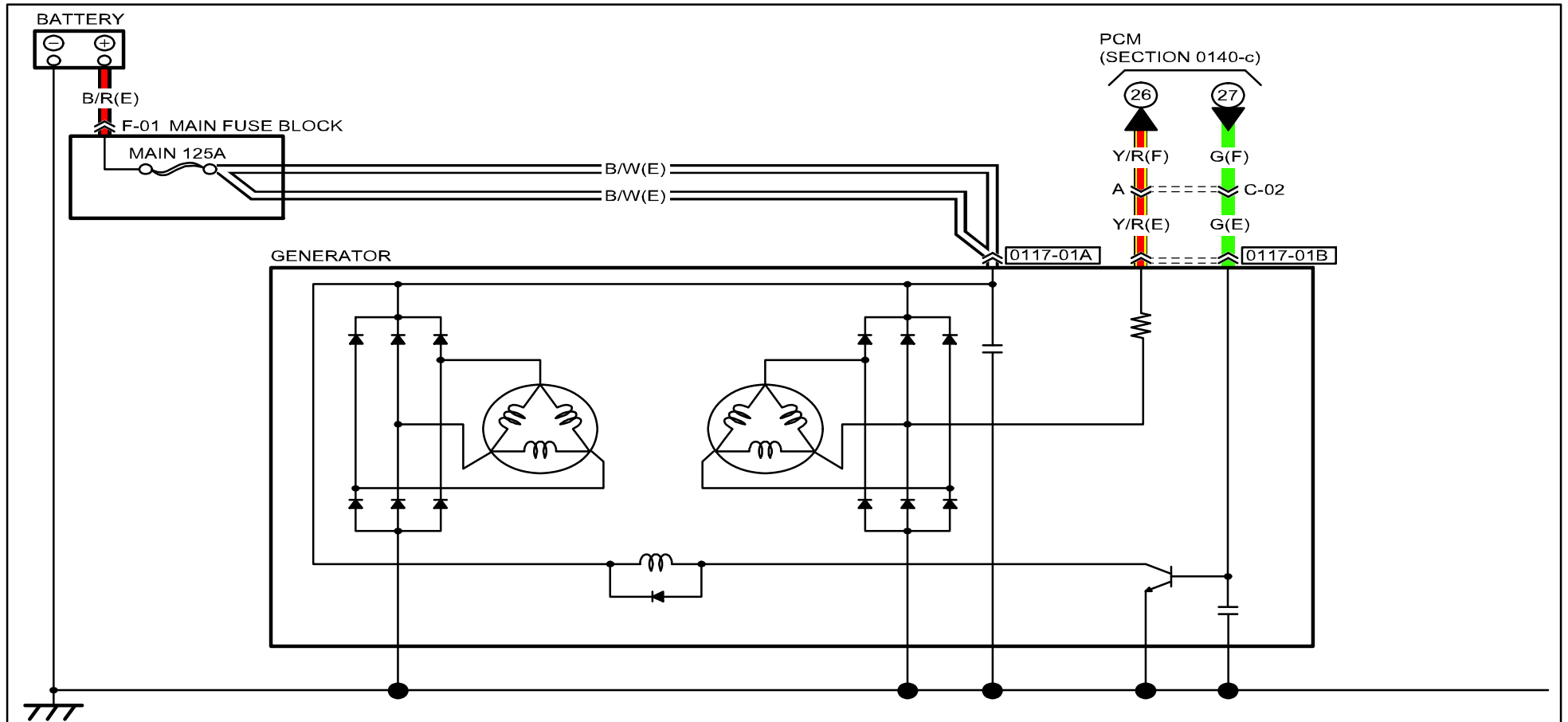
C-44
FRONT HARNESS-SHORT CORD



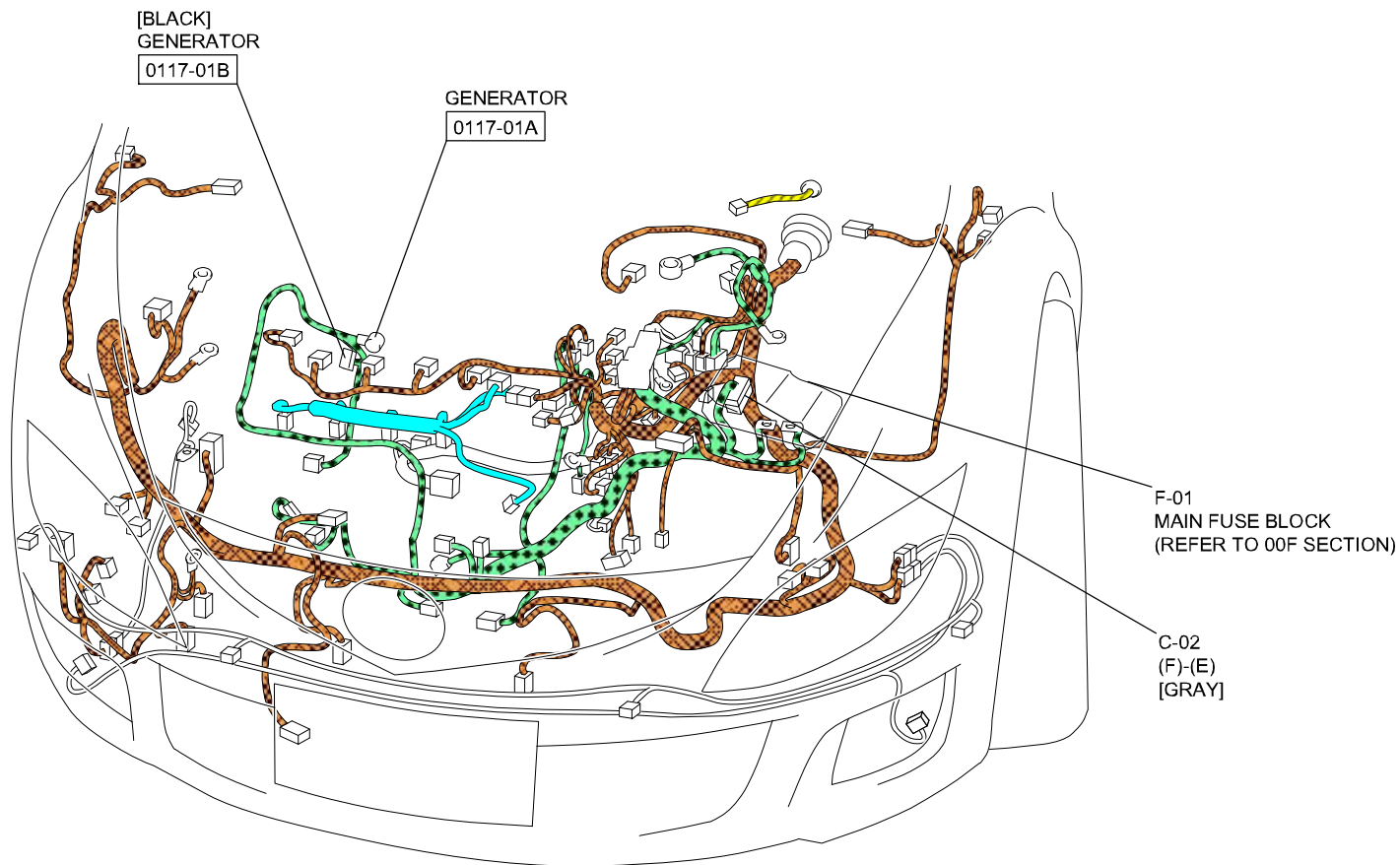

<p>0117-01A GENERATOR</p> 	<p>0117-01B GENERATOR</p> 					



-  : FRONT HARNESS
-  : ENGINE HARNESS
-  : INJECTION HARNESS
-  : REAR HARNESS

C-02

FRONT HARNESS-ENGINE HARNESS

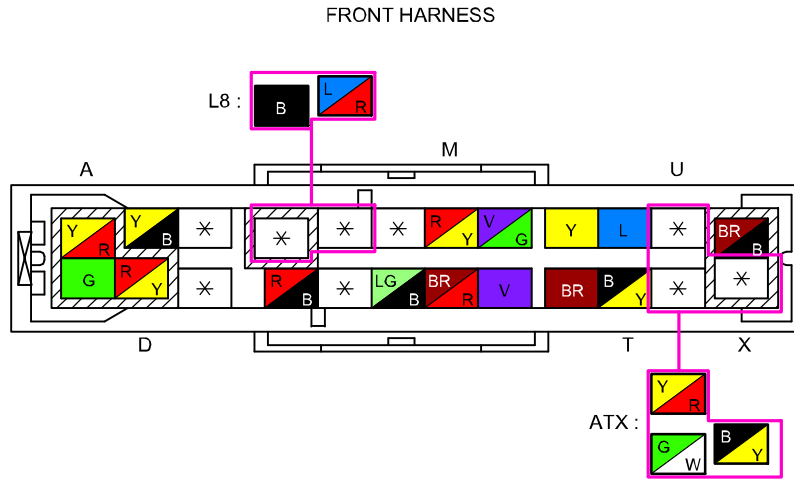

(EXCEPT MZR-CD (RF Turbo))

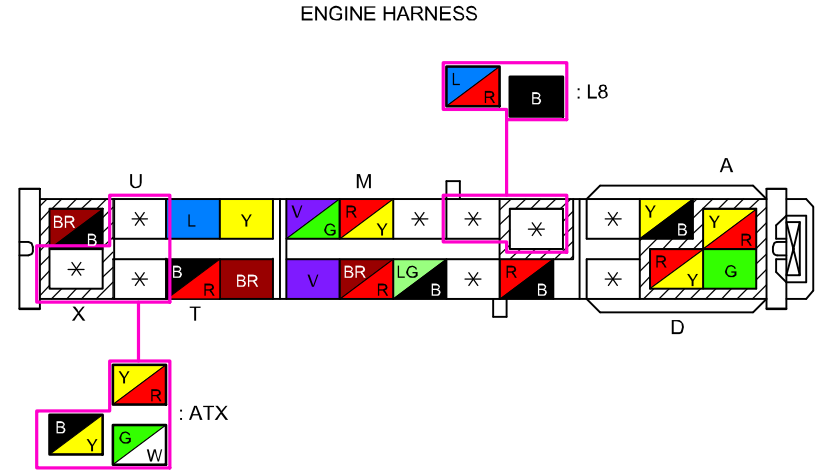

FRONT HARNESS

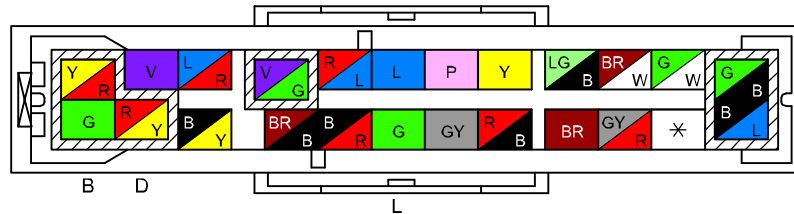

(MZR-CD (RF Turbo))

ENGINE HARNESS

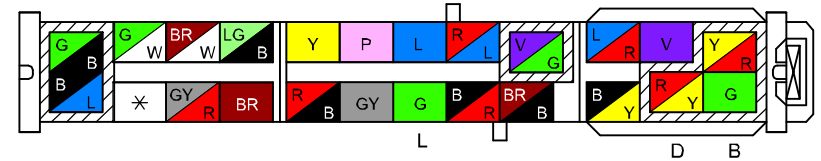

CHARGING SYSTEM (MZR-CD (RF Turbo))

0117-2

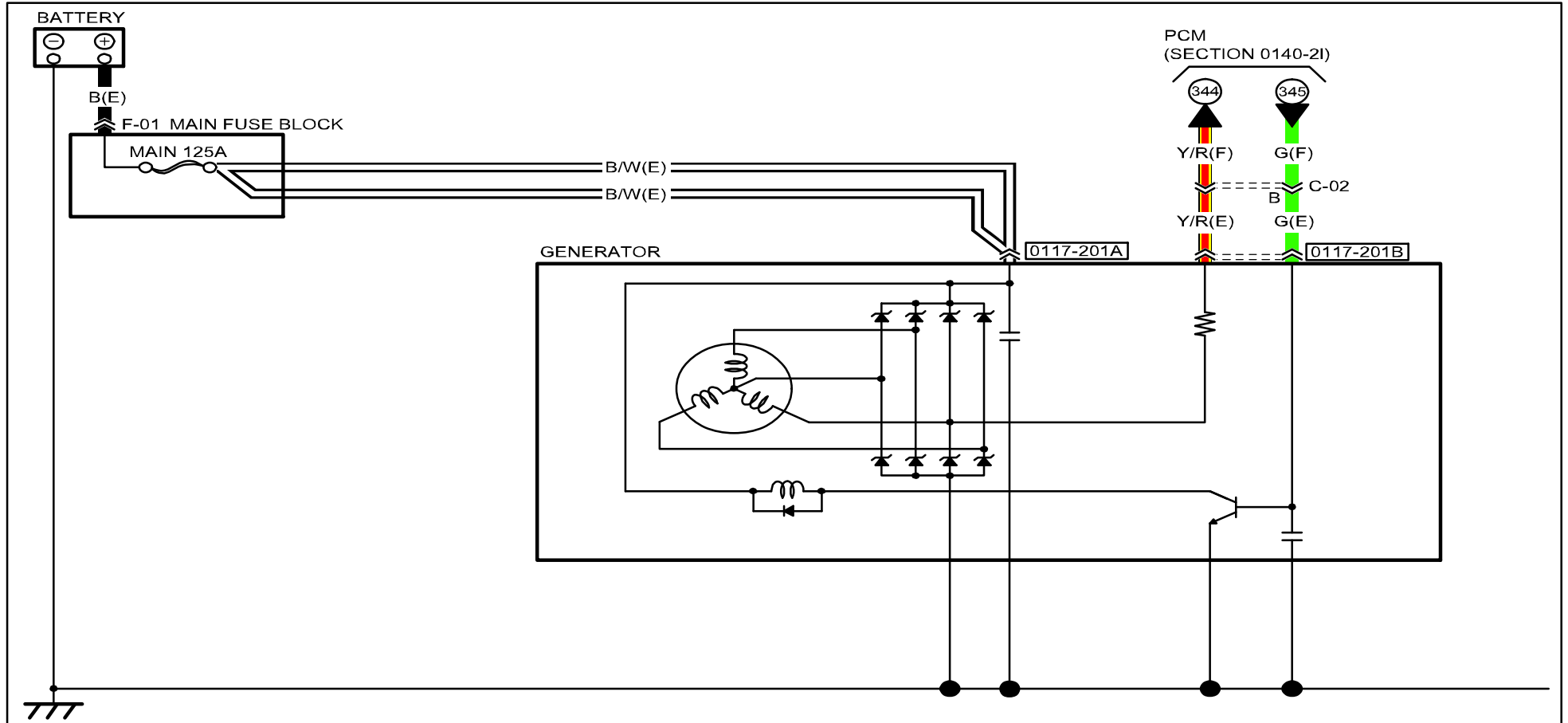

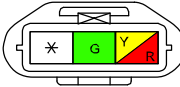
<p>0117-201A GENERATOR</p> 	<p>0117-201B GENERATOR</p> 					

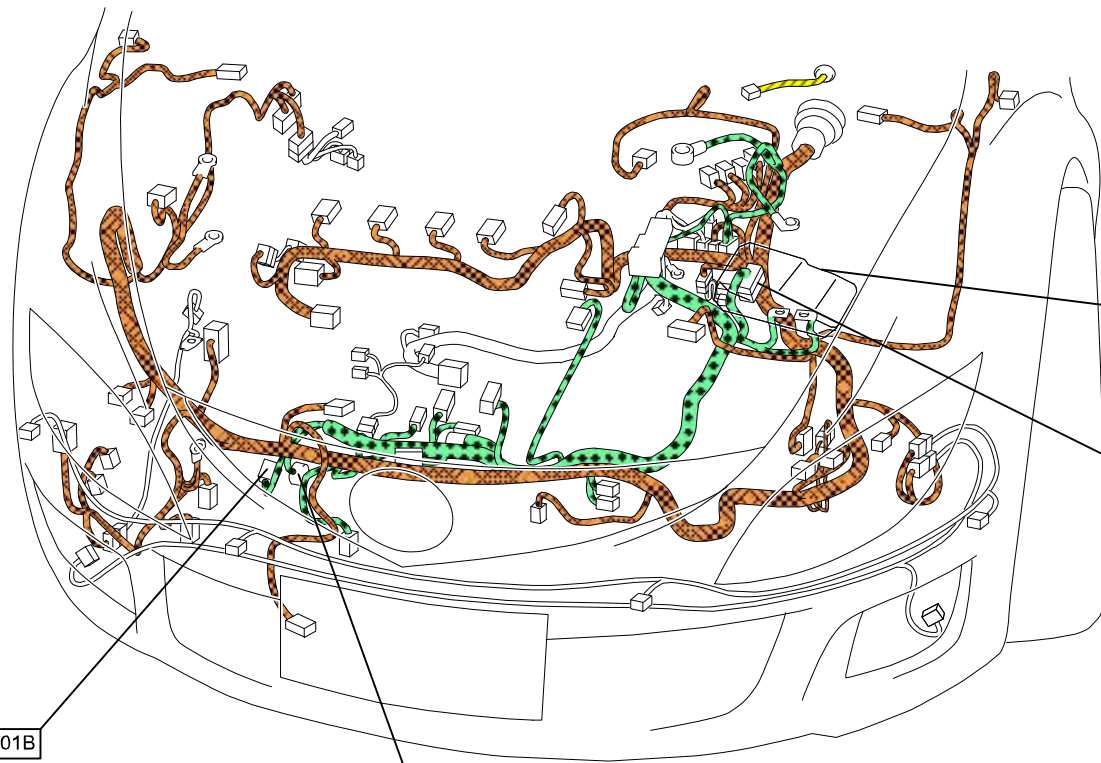



F-01
MAIN FUSE BLOCK
(REFER TO 00F SECTION)

C-02
(F)-(E)
[GRAY]

0117-201B
GENERATOR
[BLACK]

0117-201A
GENERATOR

-  : FRONT HARNESS
-  : ENGINE HARNESS
-  : REAR HARNESS

C-02
FRONT HARNESS-ENGINE HARNESS

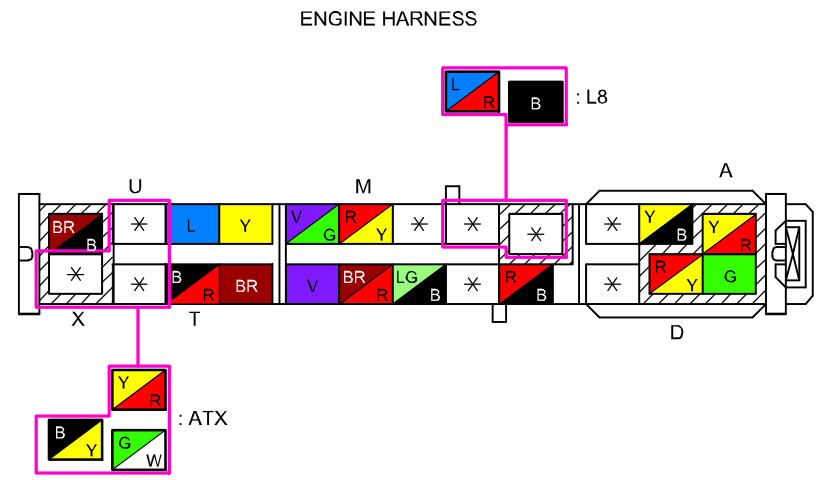
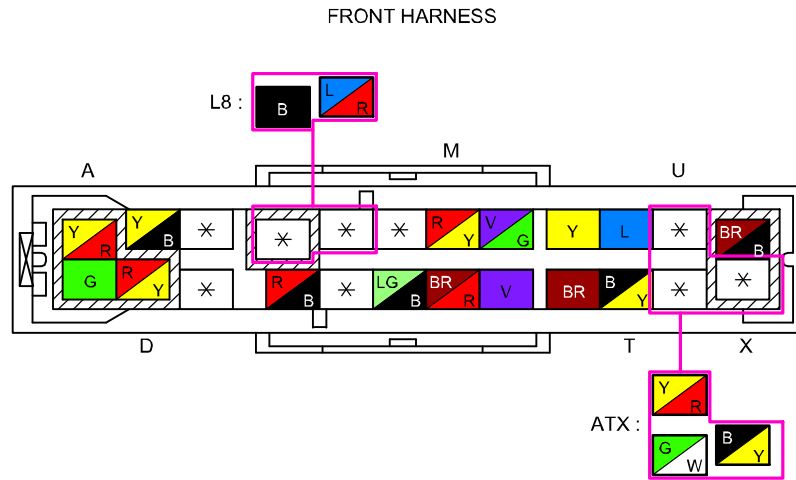

(EXCEPT MZR-CD (RF Turbo))

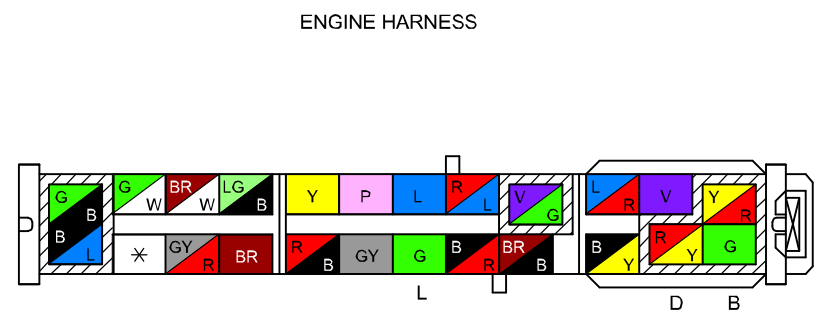
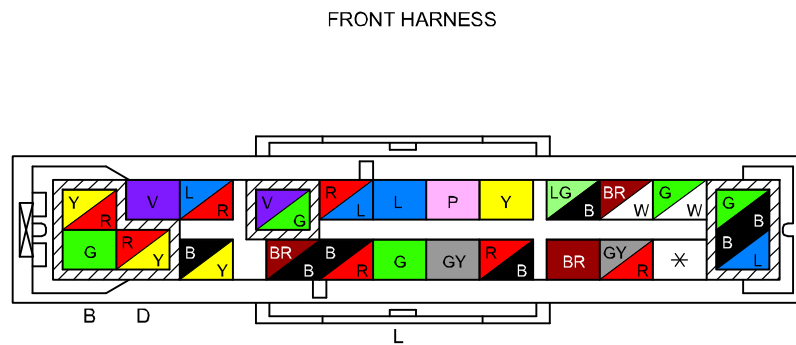



(MZR-CD (RF Turbo))

STARTING SYSTEM

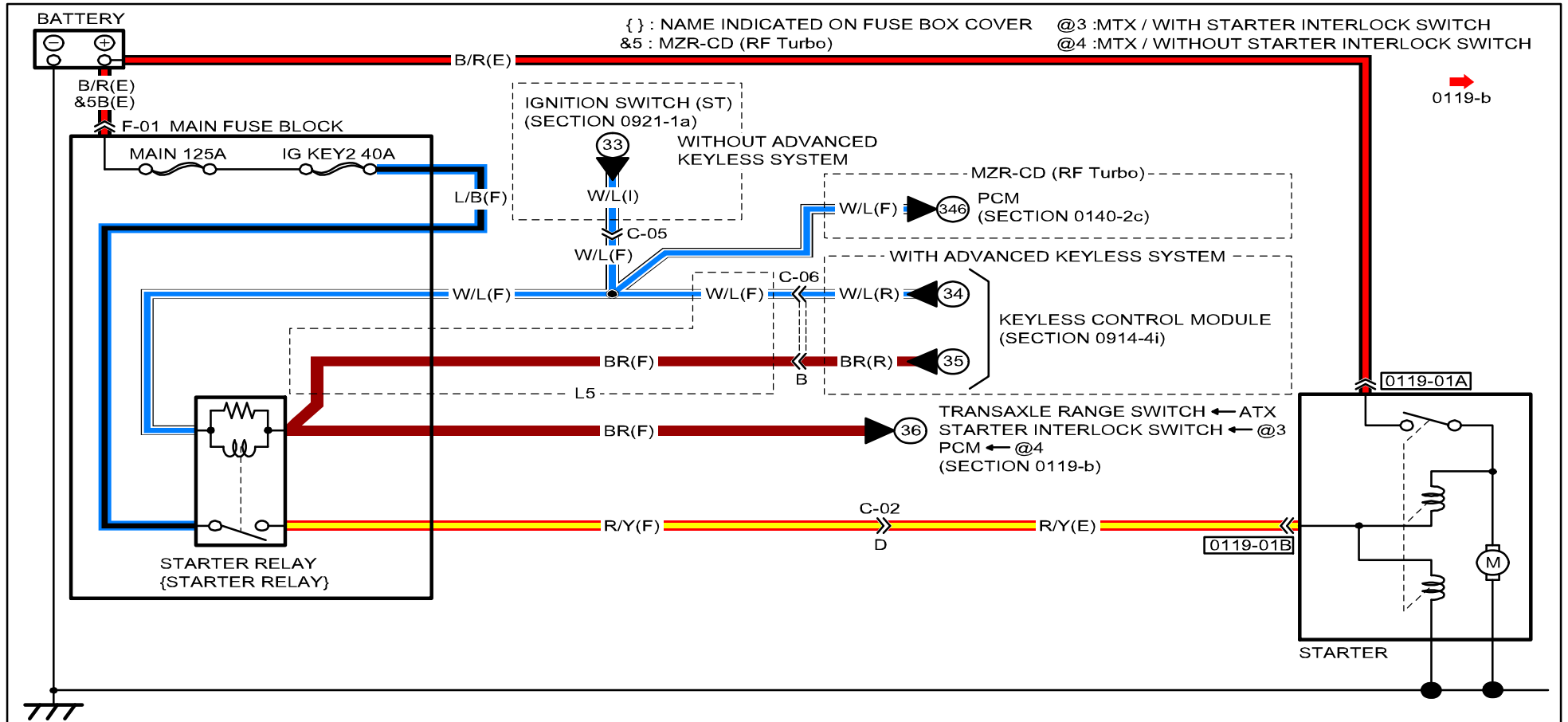
0119-a



<p>0119-01A STARTER</p> 	<p>0119-01B STARTER</p> 					

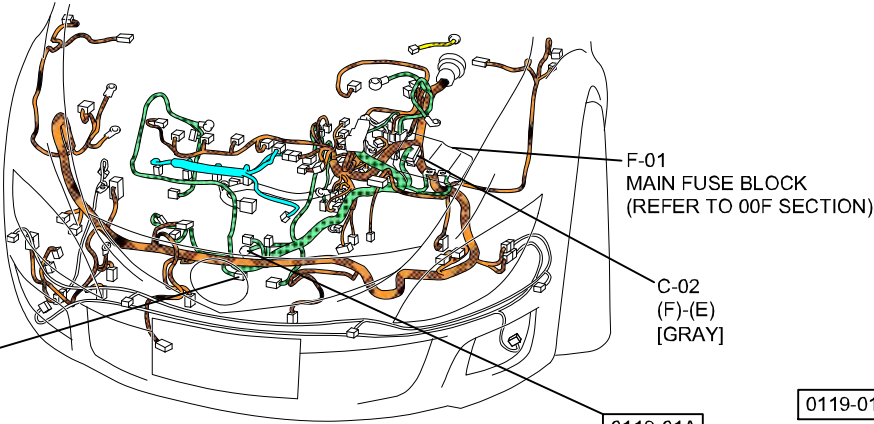

[EXCEPT MZR-CD (RF Turbo)]

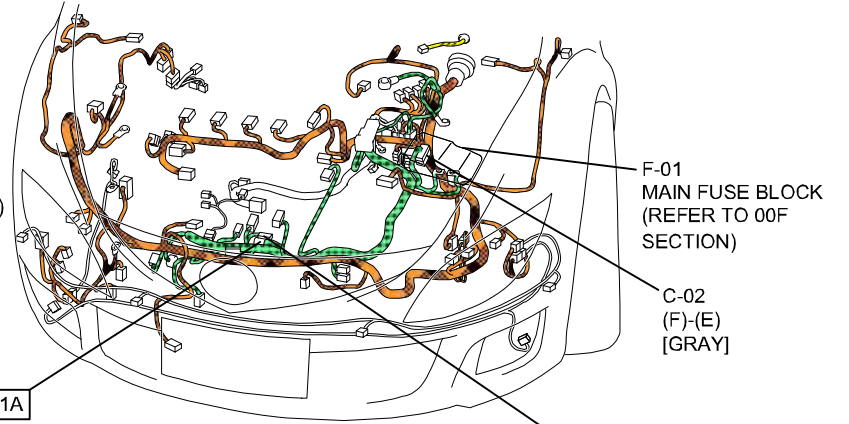

[MZR-CD (RF Turbo)]

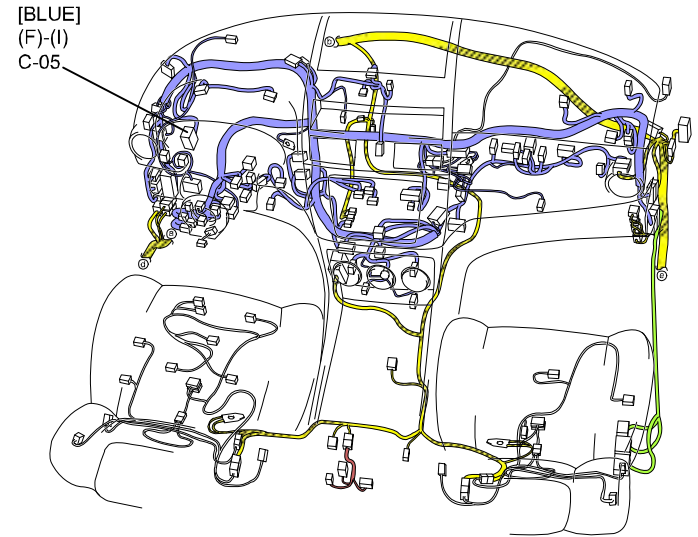
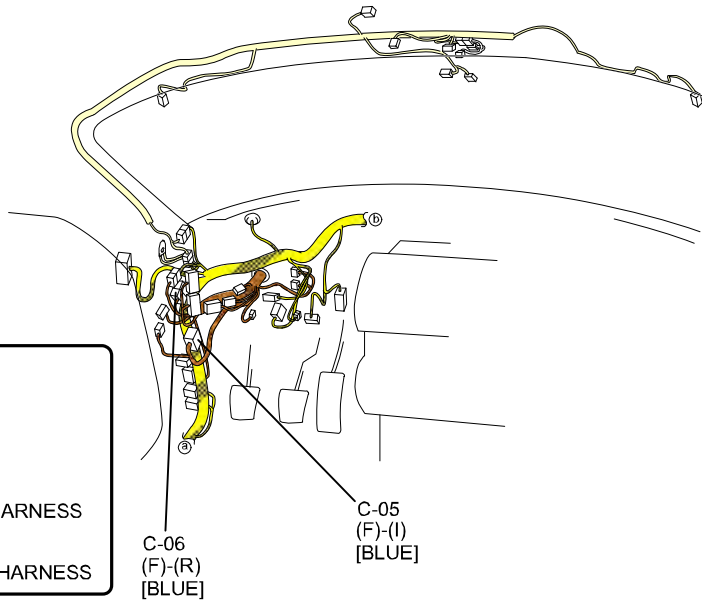

- : FRONT HARNESS
- : ENGINE HARNESS
- : INJECTION HARNESS
- : REAR HARNESS
- : REAR NO.5 HARNESS
- : INSTRUMENT PANEL HARNESS
- : FLOOR HARNESS
- : INTERIOR LIGHT NO.2 HARNESS

STARTING SYSTEM

0119-a

C-02

FRONT HARNESS-ENGINE HARNESS

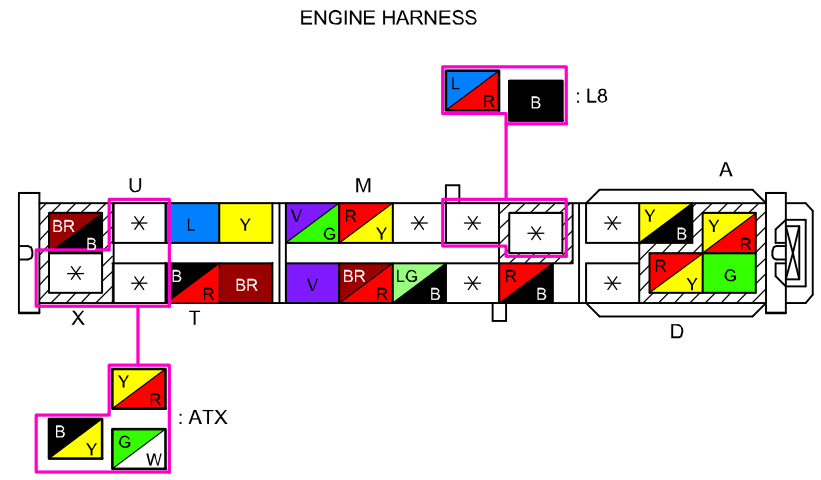
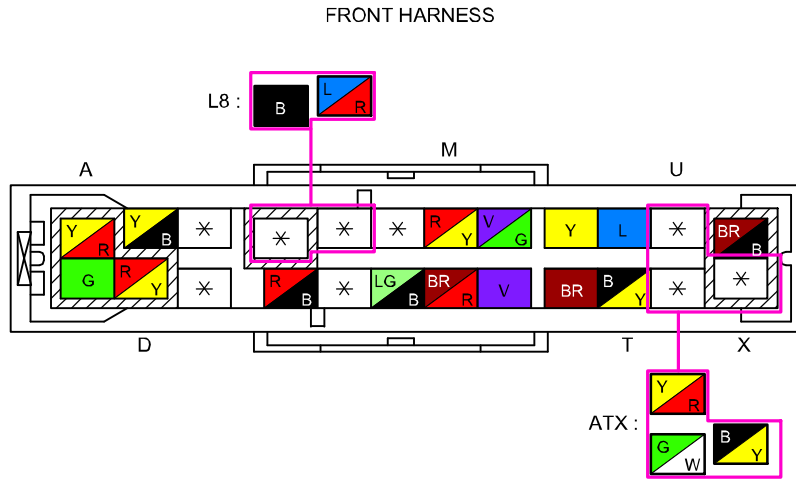

(EXCEPT MZR-CD (RF Turbo))

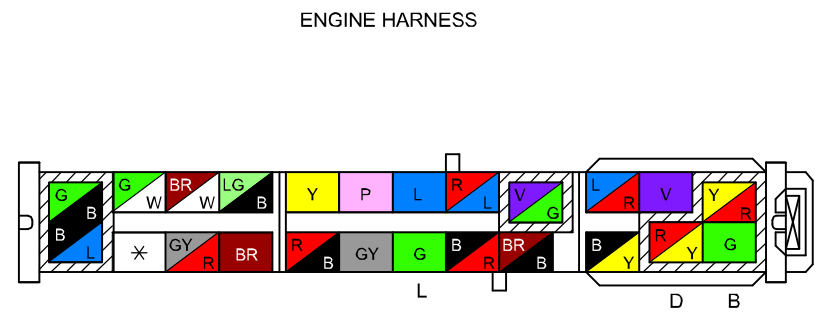
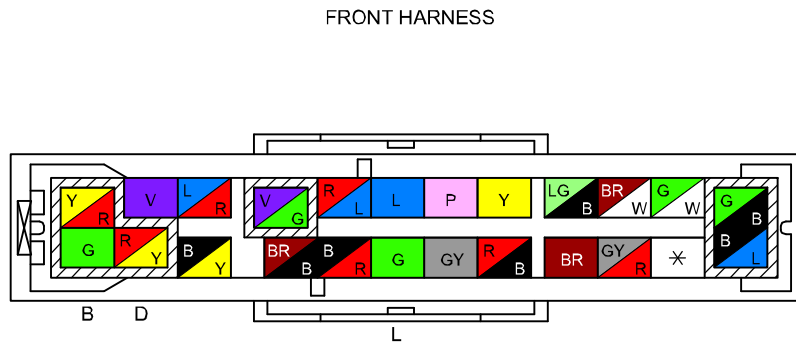

(MZR-CD (RF Turbo))

STARTING SYSTEM

0119-a

C-05 FRONT HARNESS-INSTRUMENT PANEL HARNESS

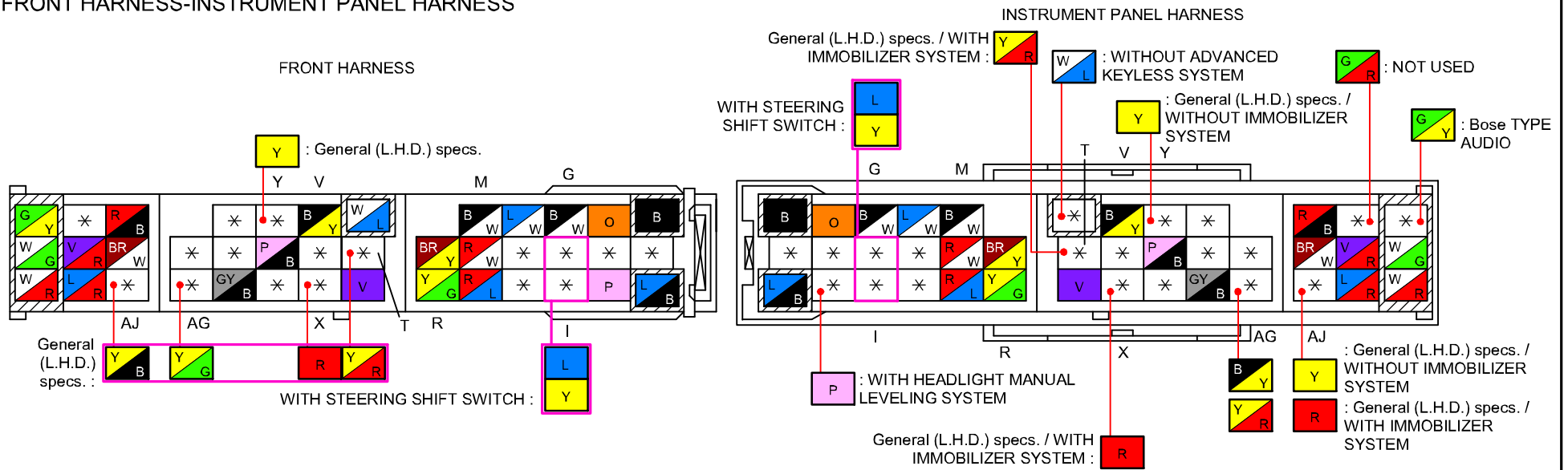

C-06 FRONT HARNESS-REAR HARNESS

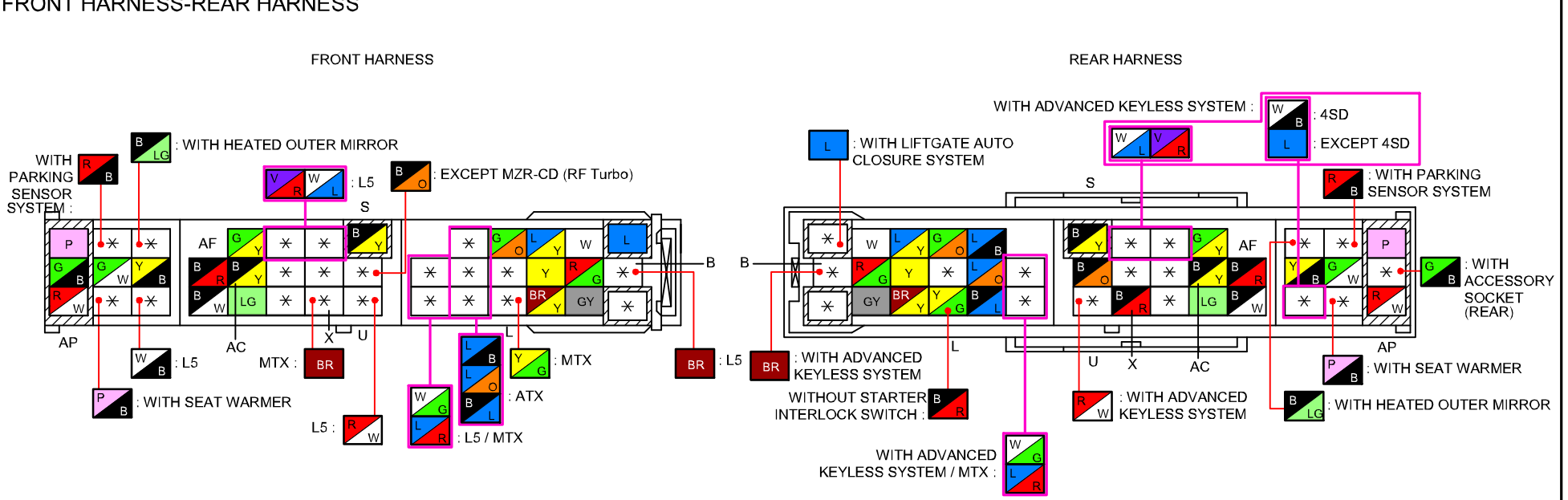

STARTING SYSTEM

0119-b

0119-a

- #4 : European (L.H.D.) specs.
- & : WITHOUT STARTER INTERLOCK SWITCH
- &4 : General (L.H.D.) specs.
- &8 : WITH IMMOBILIZER SYSTEM
- &9 : WITHOUT IMMOBILIZER SYSTEM

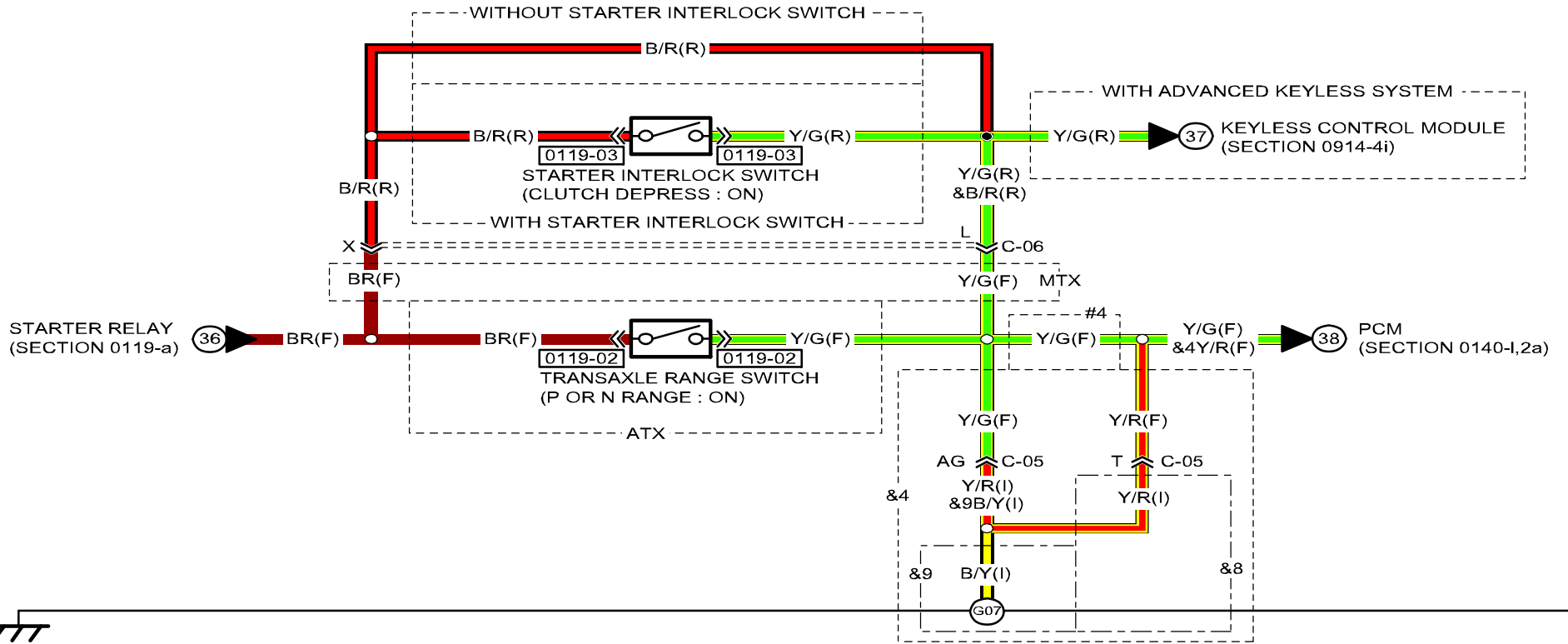

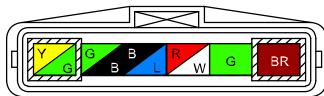

0119-02
TRANSAXLE RANGE SWITCH



0119-03
STARTER INTERLOCK SWITCH

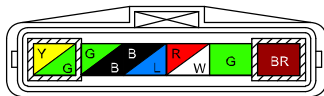

<p>0119-02 TRANSAXLE RANGE SWITCH</p> 	<p>0119-03 STARTER INTERLOCK SWITCH</p> 			

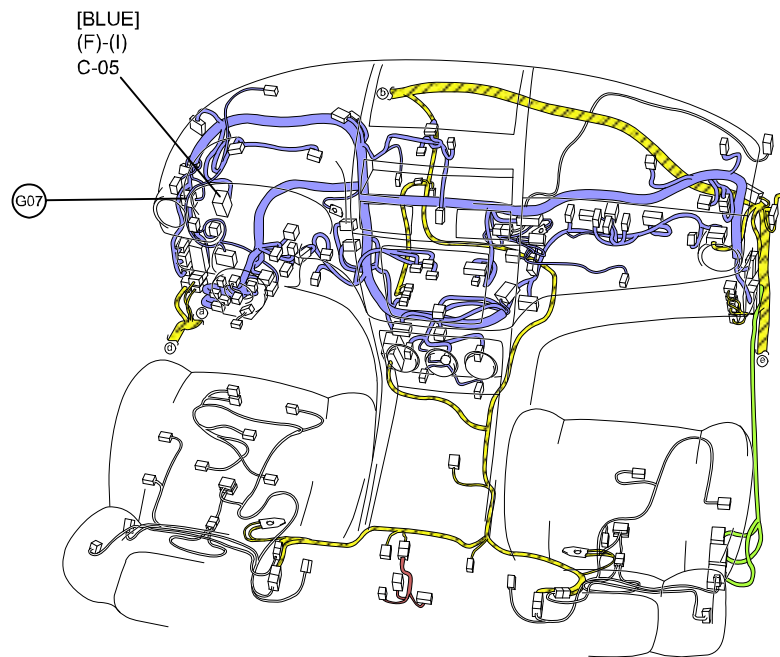
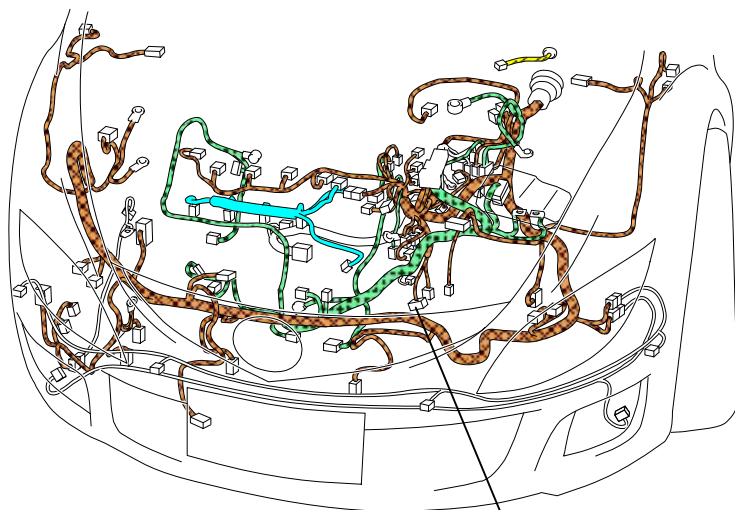









[BLUE]
(F)-(R)
C-06

0119-02
TRANSAXLE RANGE SWITCH
[BLACK]

STARTER INTERLOCK SWITCH
0119-03

C-05
(F)-(L)
[BLUE]

-  : FRONT HARNESS
-  : ENGINE HARNESS
-  : INJECTION HARNESS
-  : REAR HARNESS
-  : REAR NO.5 HARNESS
-  : INSTRUMENT PANEL HARNESS
-  : FLOOR HARNESS
-  : INTERIOR LIGHT NO.2 HARNESS

STARTING SYSTEM

0119-b

C-05 FRONT HARNESS-INSTRUMENT PANEL HARNESS

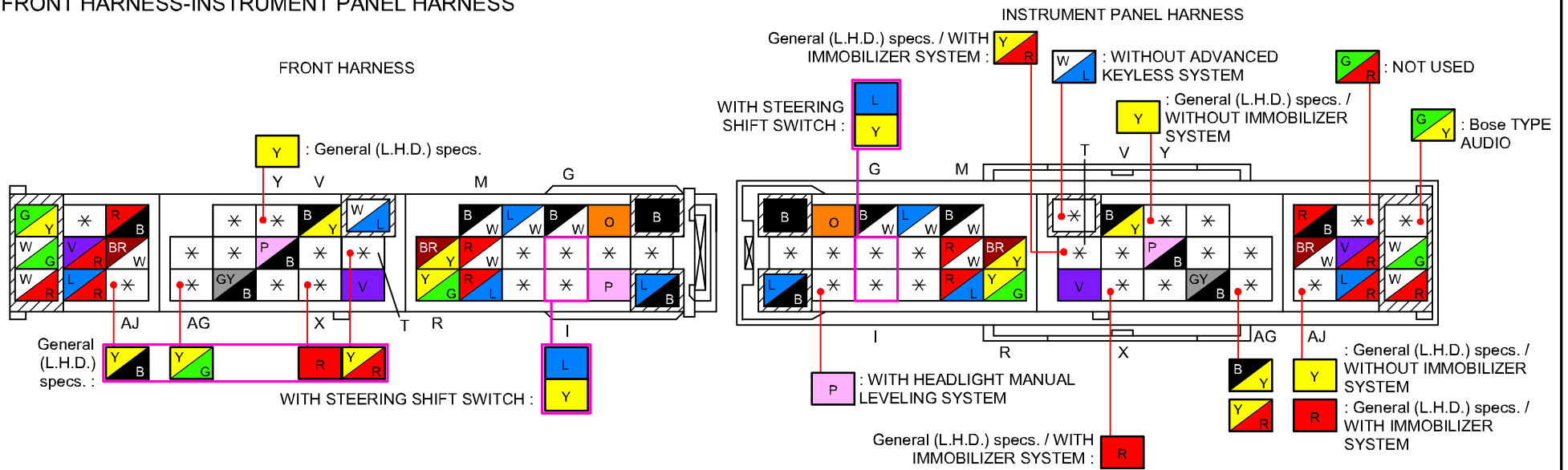

C-06 FRONT HARNESS-REAR HARNESS

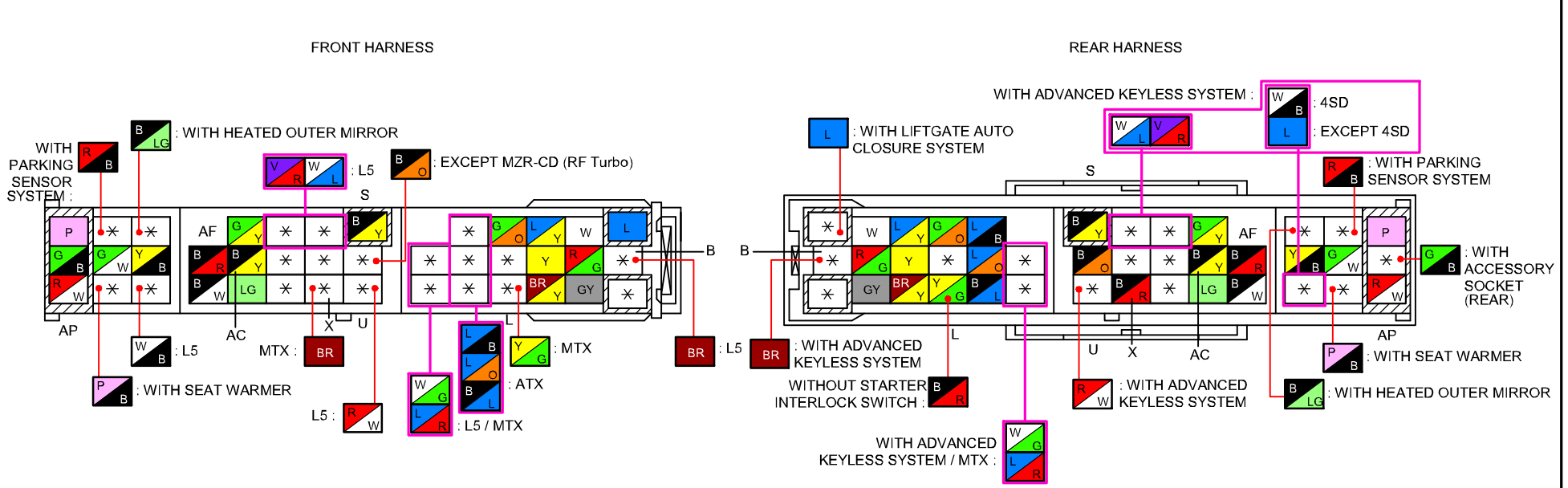

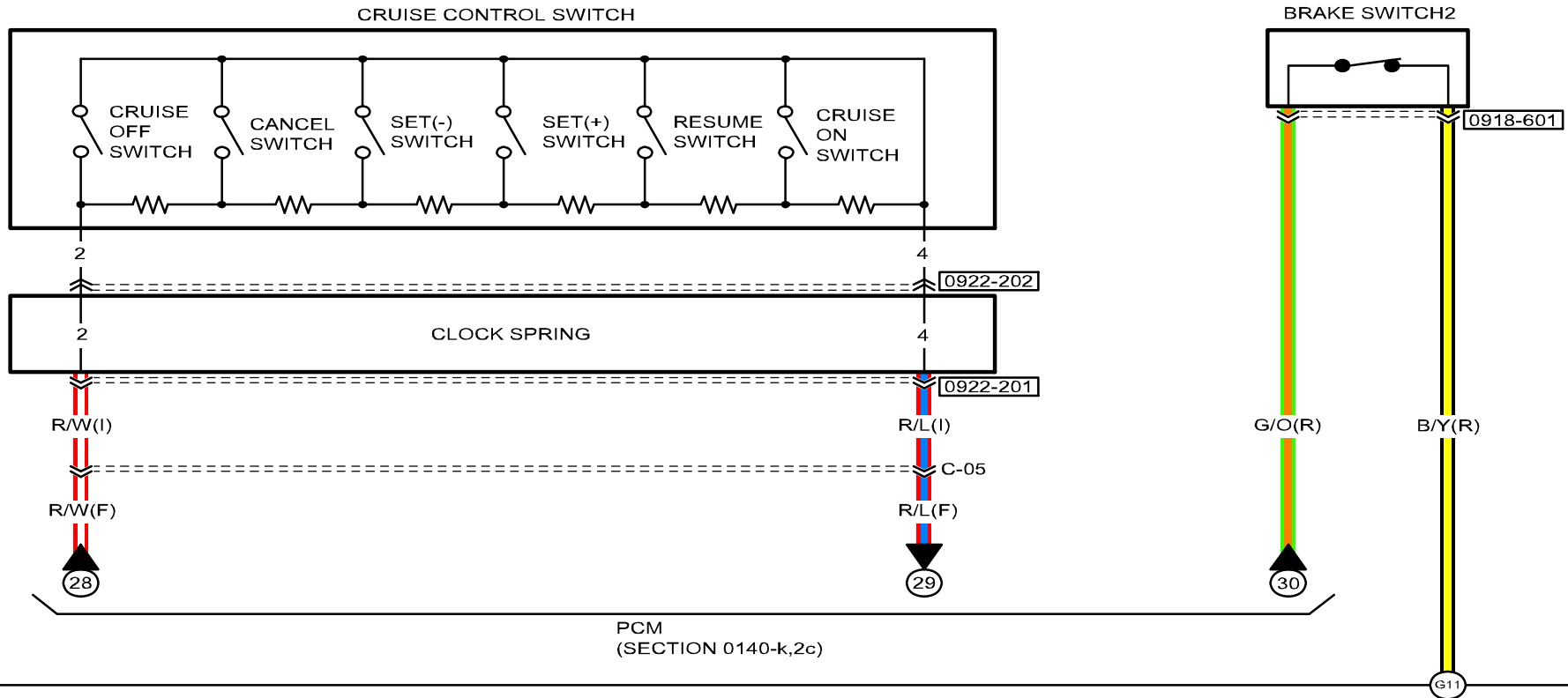

0918-601
BRAKE SWITCH /
BRAKE SWITCH2

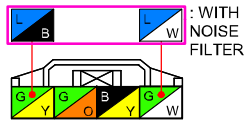

0922-201
CLOCK SPRING

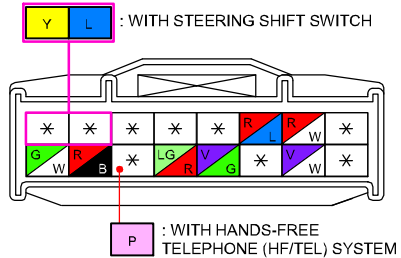

0922-202
CRUISE CONTROL SWITCH /
UP SWITCH / DOWN SWITCH /
STEERING SWITCH ILLUMINATION /
UP SWITCH ILLUMINATION /
DOWN SWITCH ILLUMINATION /
CRUISE CONTROL SWITCH
ILLUMINATION /
STEERING SWITCH /
CLOCK SPRING

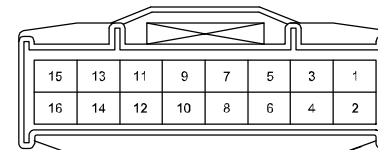

TERMINALS OF THIS CONNECTOR ARE INDICATED BY NUMBERS.

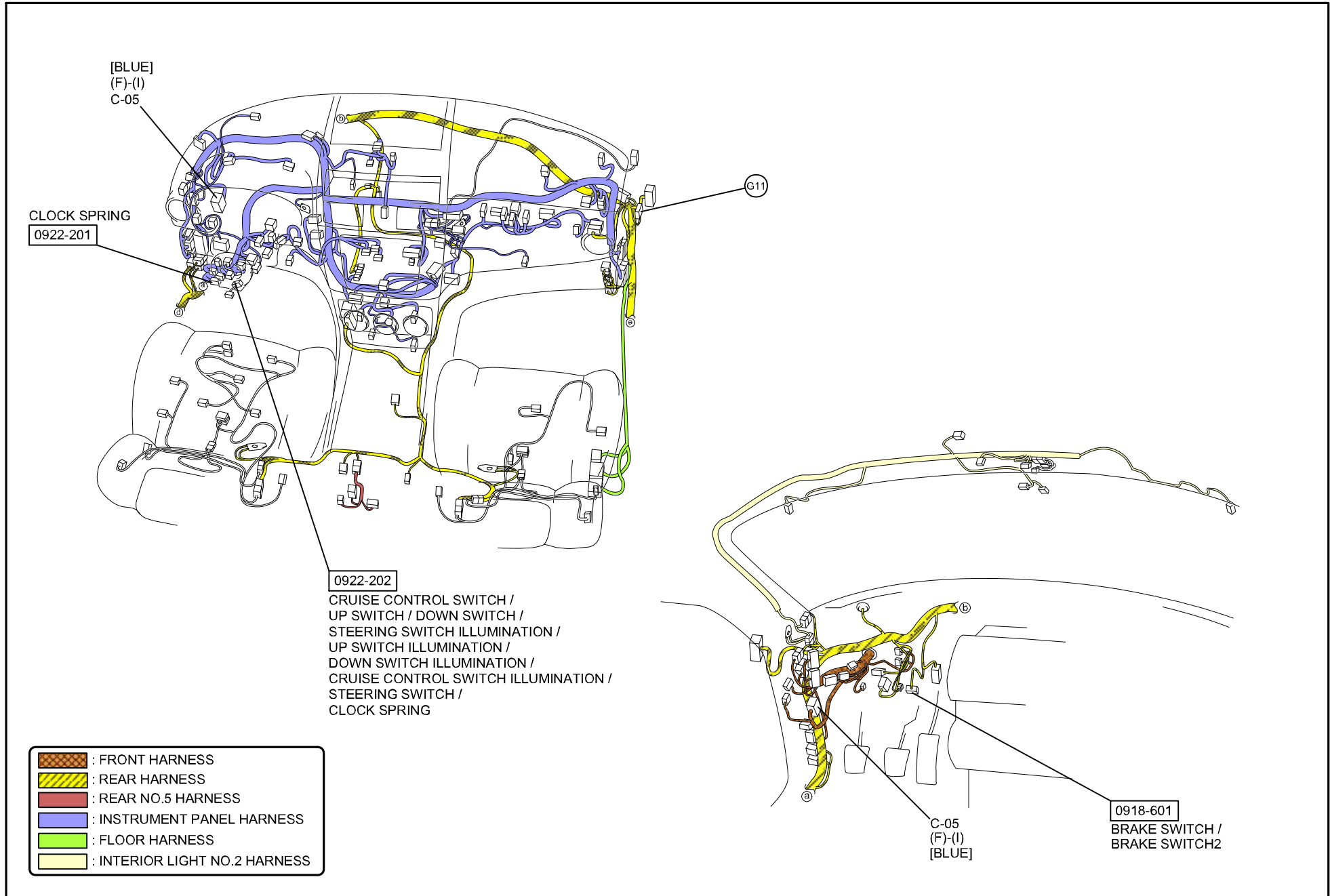

CONTROL SYSTEM (EXCEPT MZR-CD (RF Turbo))

0140-a

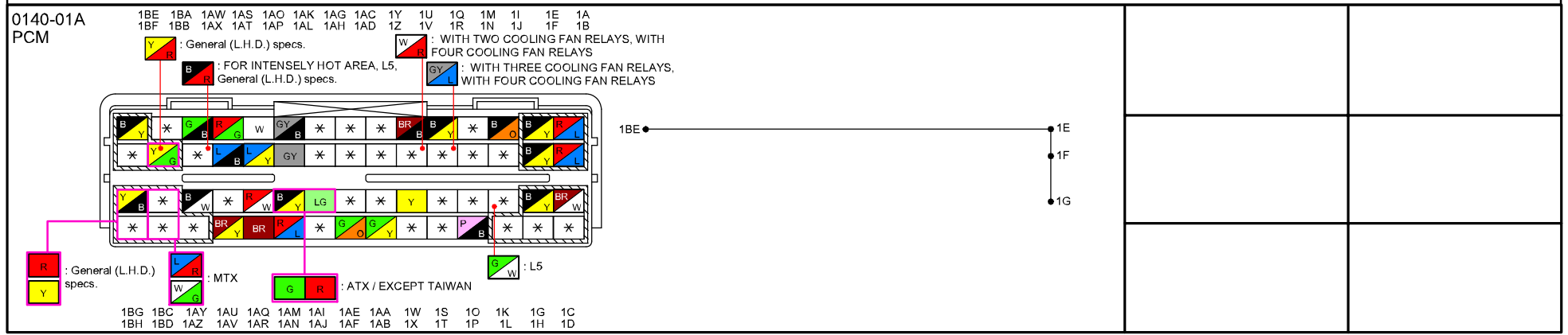
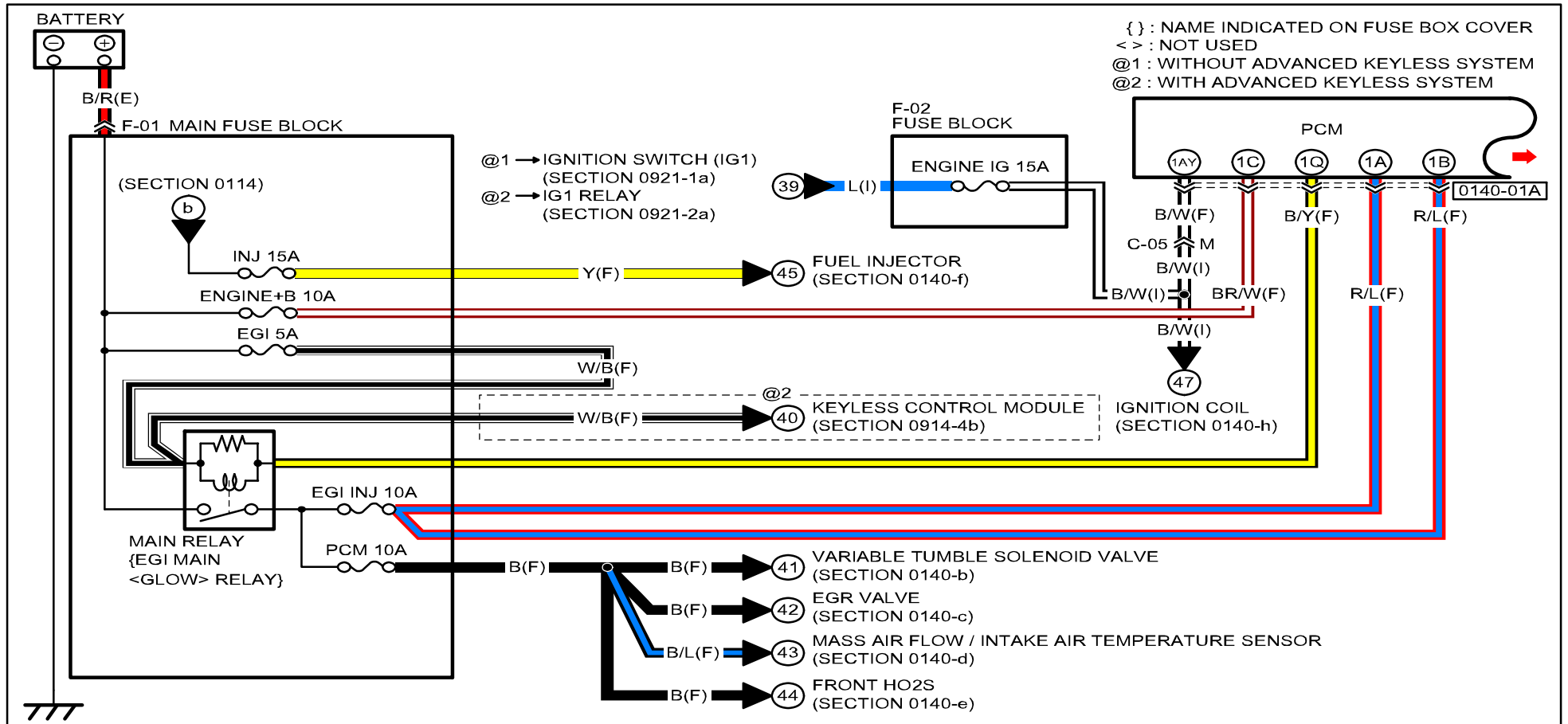

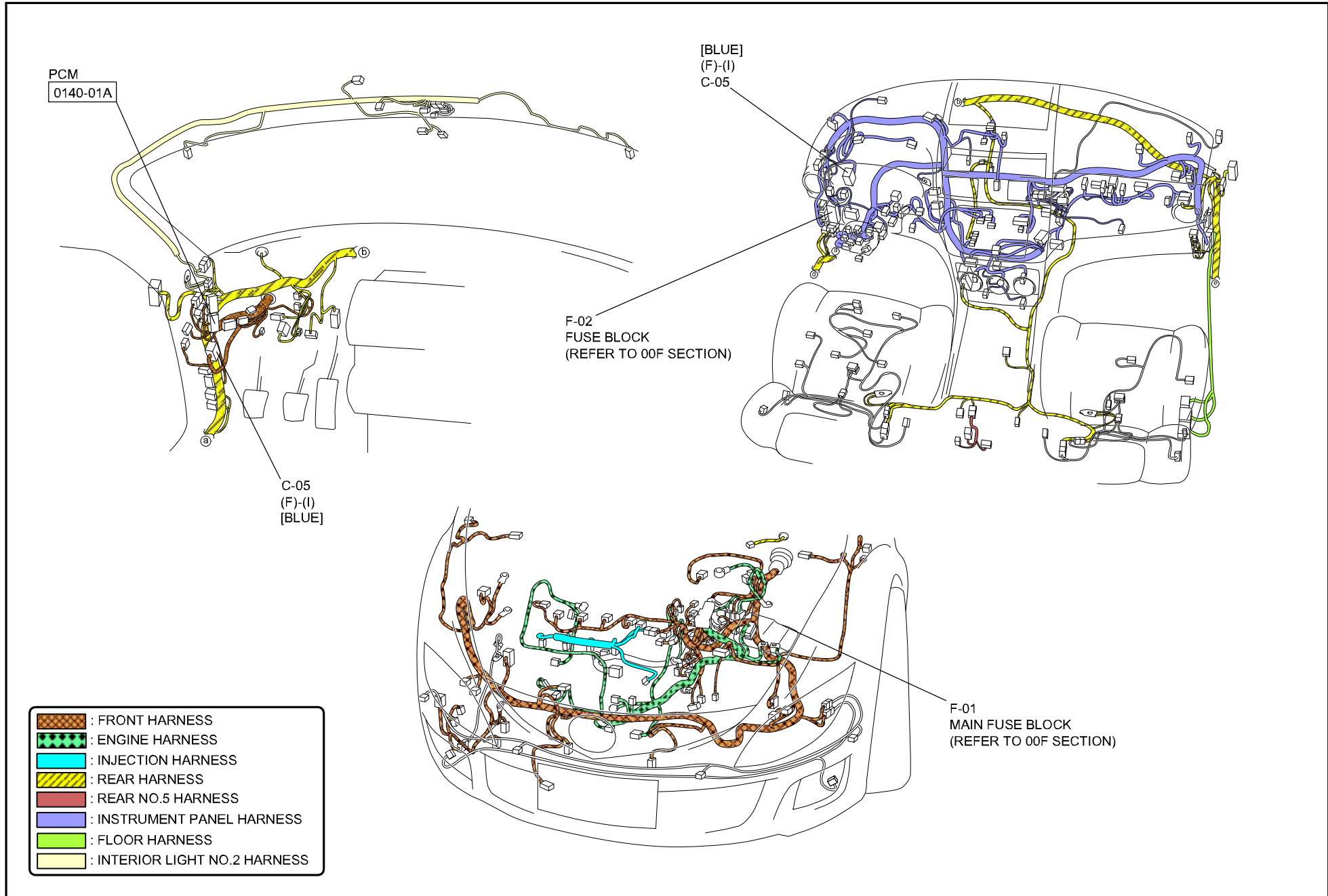

C-05

FRONT HARNESS-INSTRUMENT PANEL HARNESS

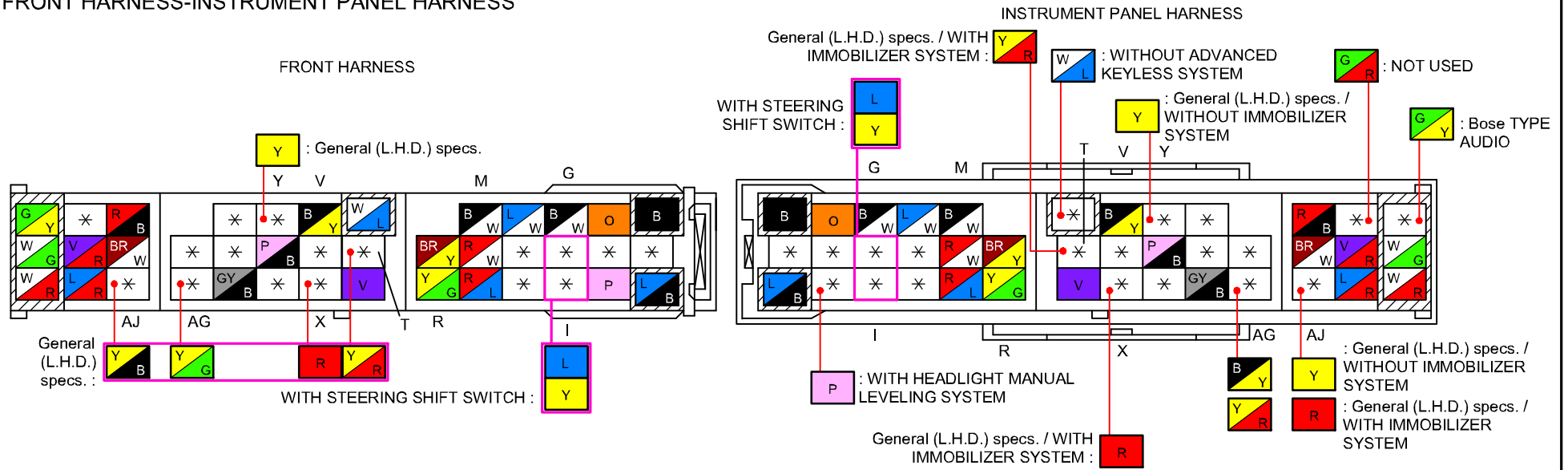

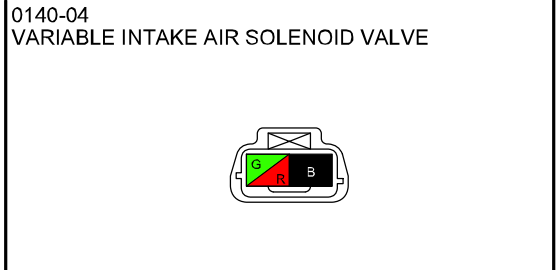
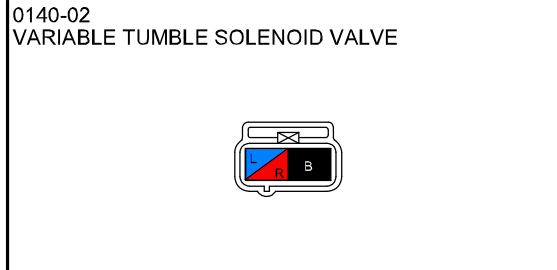
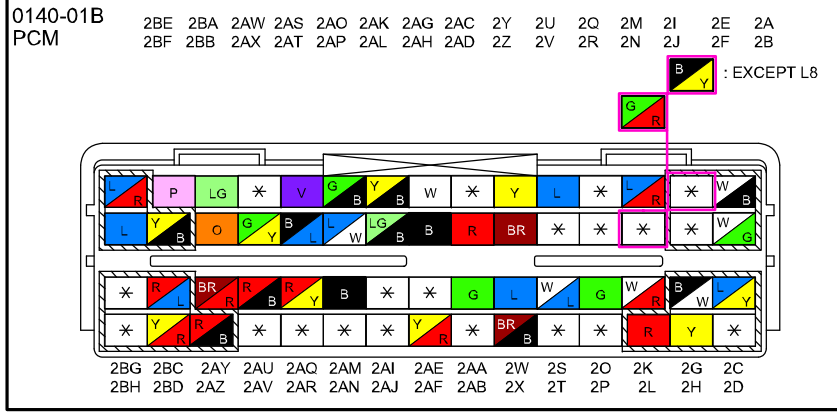
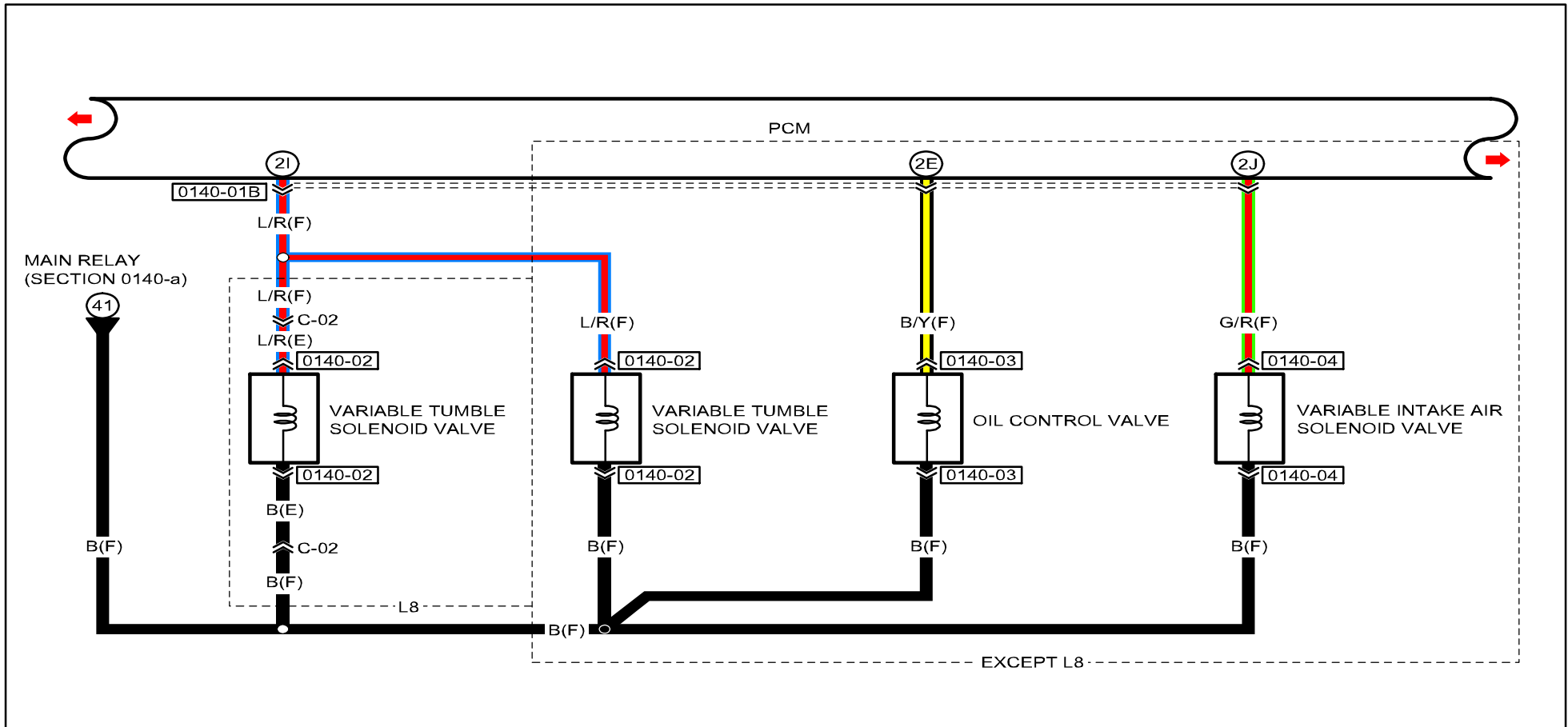

CONTROL SYSTEM (EXCEPT MZR-CD (RF Turbo))

0140-b

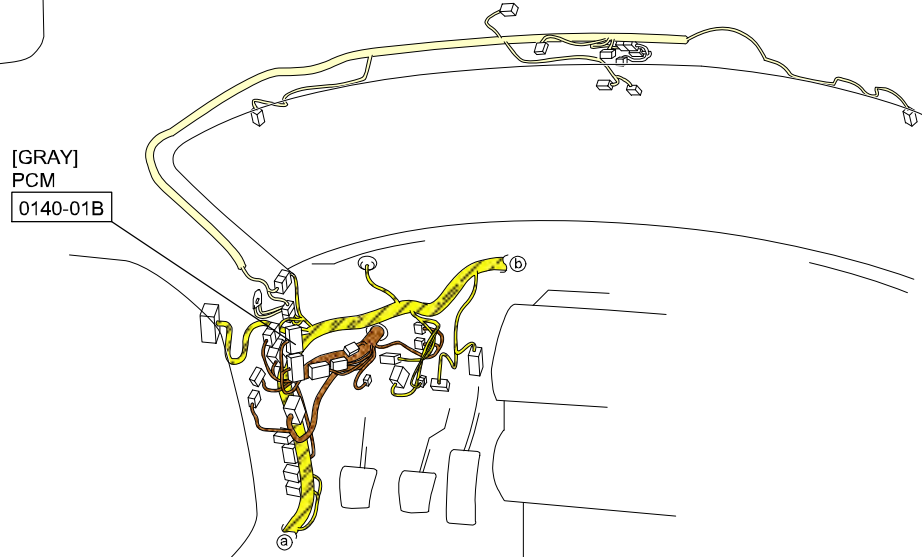
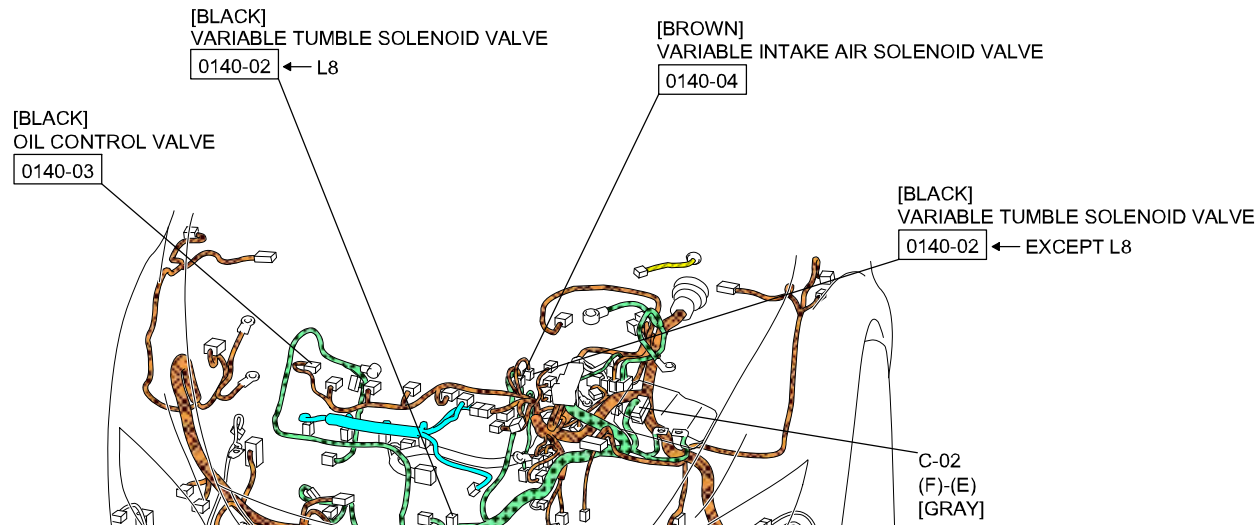

- : FRONT HARNESS
- : ENGINE HARNESS
- : INJECTION HARNESS
- : REAR HARNESS
- : INTERIOR LIGHT NO.2 HARNESS

CONTROL SYSTEM (EXCEPT MZR-CD (RF Turbo))

C-02

FRONT HARNESS-ENGINE HARNESS

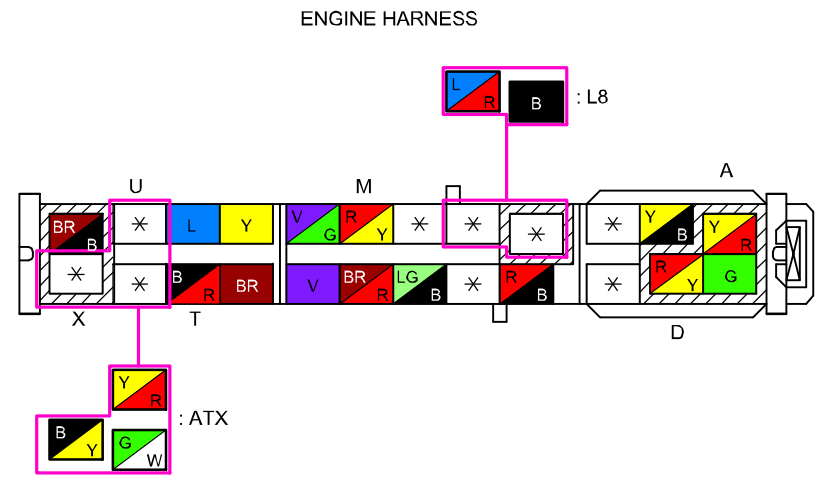
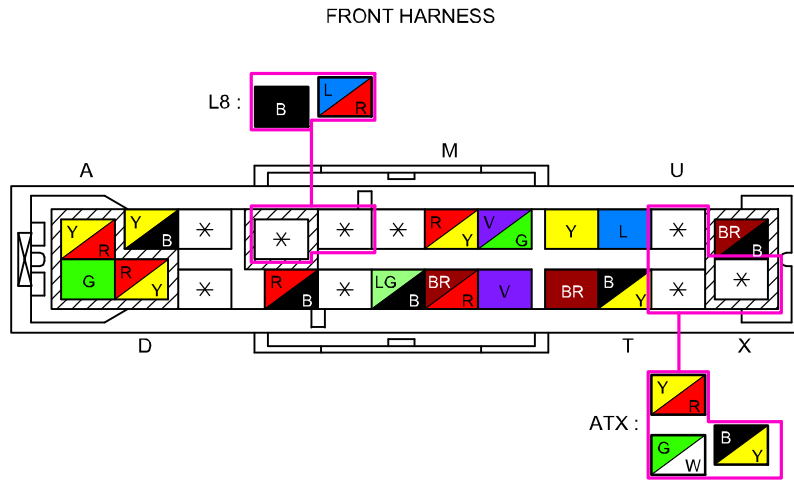

(EXCEPT MZR-CD (RF Turbo))

FRONT HARNESS

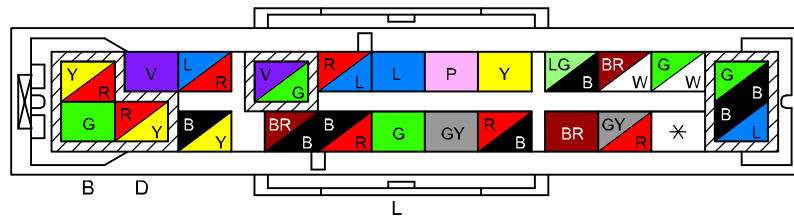

ENGINE HARNESS

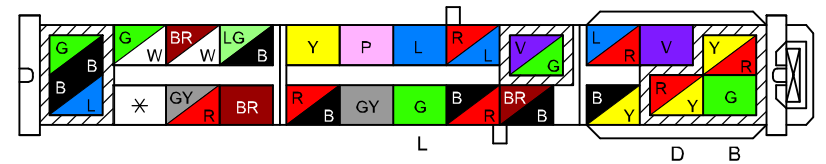

(MZR-CD (RF Turbo))

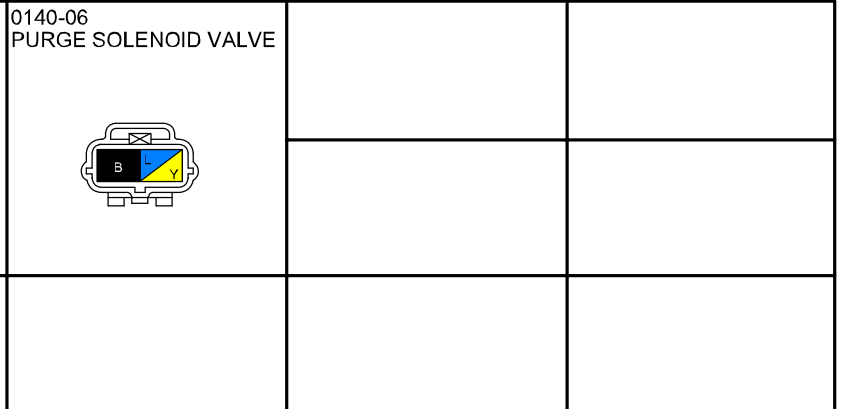
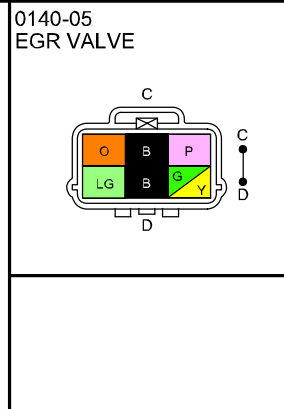
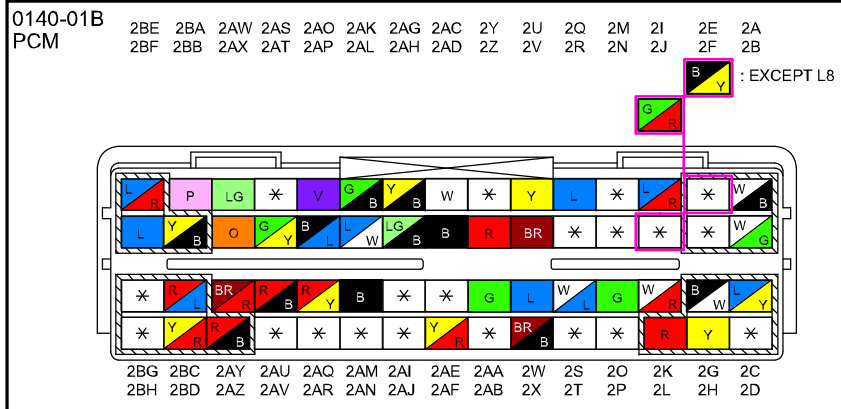
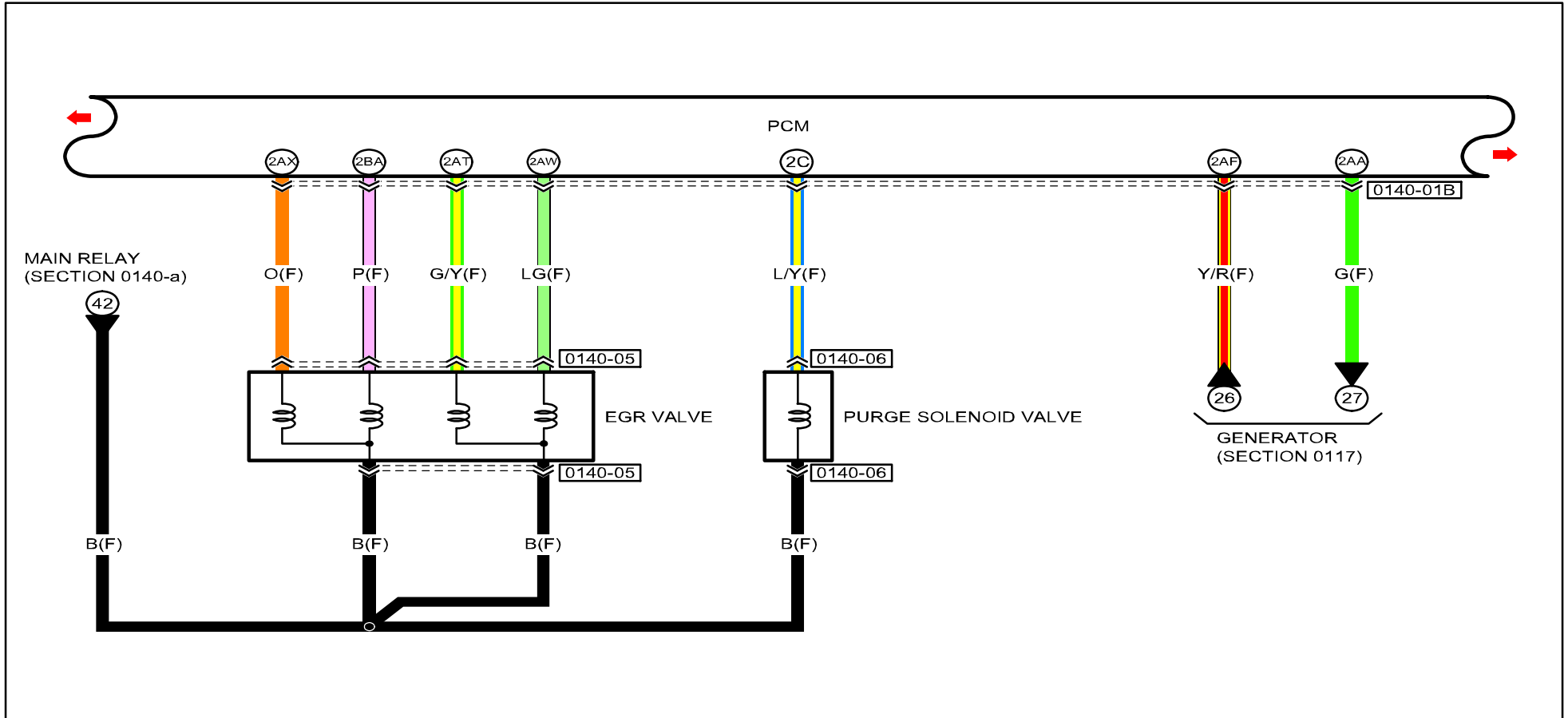

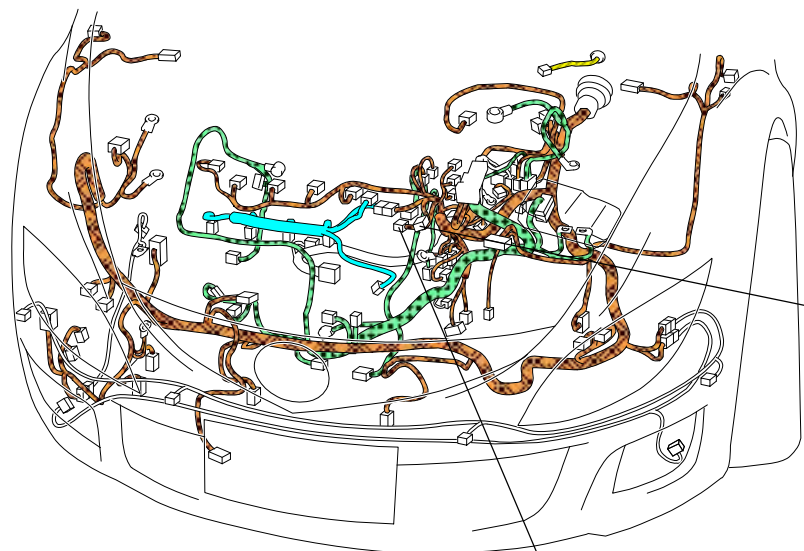





0140-06
PURGE SOLENOID VALVE
[BLACK]

[GRAY]
PCM
0140-01B

0140-05
EGR VALVE
[GRAY]



-  : FRONT HARNESS
-  : ENGINE HARNESS
-  : INJECTION HARNESS
-  : REAR HARNESS
-  : INTERIOR LIGHT NO.2 HARNESS

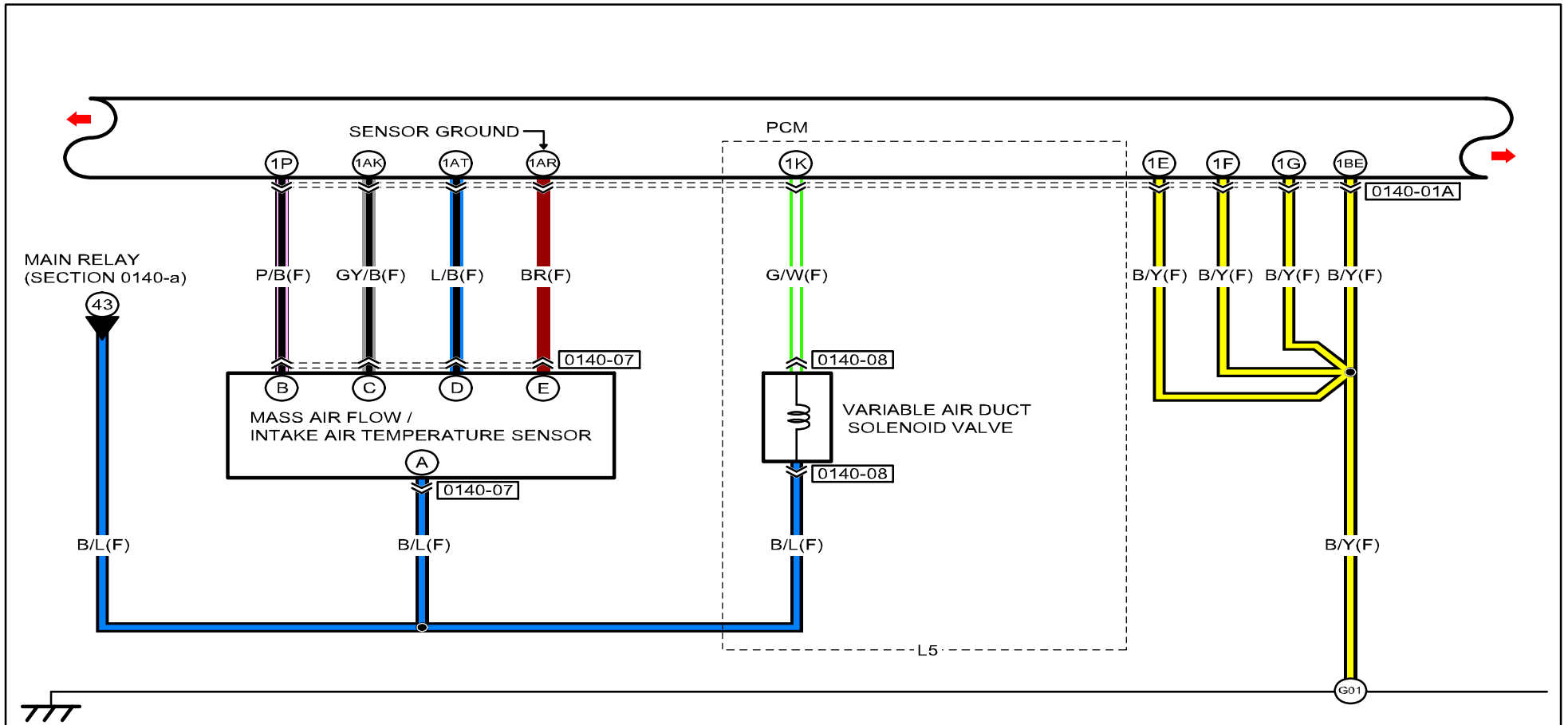

<p>0140-01A PCM</p> <p>Legend:</p> <ul style="list-style-type: none"> Y: General (L.H.D.) specs. W: WITH TWO COOLING FAN RELAYS, WITH FOUR COOLING FAN RELAYS R: FOR INTENSELY HOT AREA, L5, General (L.H.D.) specs. GY: WITH THREE COOLING FAN RELAYS, WITH FOUR COOLING FAN RELAYS L: WITH FOUR COOLING FAN RELAYS R: General (L.H.D.) specs. L: MTX G: ATX / EXCEPT TAIWAN W: L5 <p>Terminal List:</p> <p>1BE 1BA 1AW 1AS 1AO 1AK 1AG 1AC 1Y 1U 1Q 1M 1I 1E 1A 1BF 1BB 1AX 1AT 1AP 1AL 1AH 1AD 1Z 1V 1R 1N 1J 1F 1B</p> <p>1BG 1BC 1AY 1AU 1AQ 1AM 1AI 1AE 1AA 1W 1S 1O 1K 1G 1C 1BH 1BD 1AZ 1AV 1AR 1AN 1AJ 1AF 1AB 1X 1T 1P 1L 1H 1D</p>	<p>0140-07 MASS AIR FLOW / INTAKE AIR TEMPERATURE SENSOR</p>	<p>0140-08 VARIABLE AIR DUCT SOLENOID VALVE</p>
---	---	--

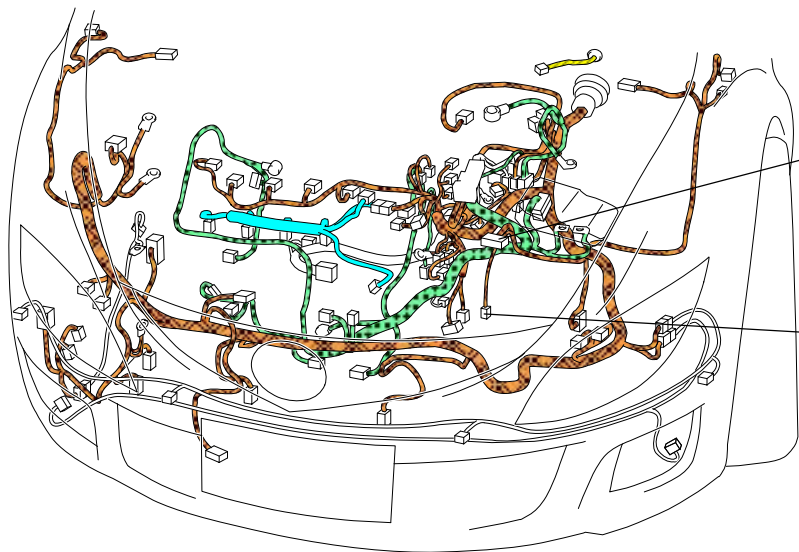



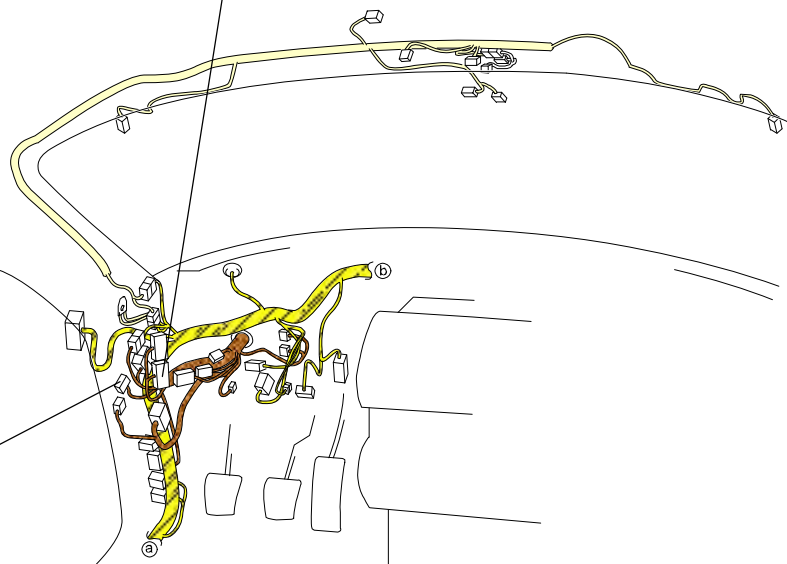

[BLACK]
MASS AIR FLOW /
INTAKE AIR TEMPERATURE SENSOR
0140-07

0140-08
VARIABLE AIR DUCT SOLENOID VALVE
[GREEN]

PCM
0140-01A



-  : FRONT HARNESS
-  : ENGINE HARNESS
-  : INJECTION HARNESS
-  : REAR HARNESS
-  : INTERIOR LIGHT NO.2 HARNESS

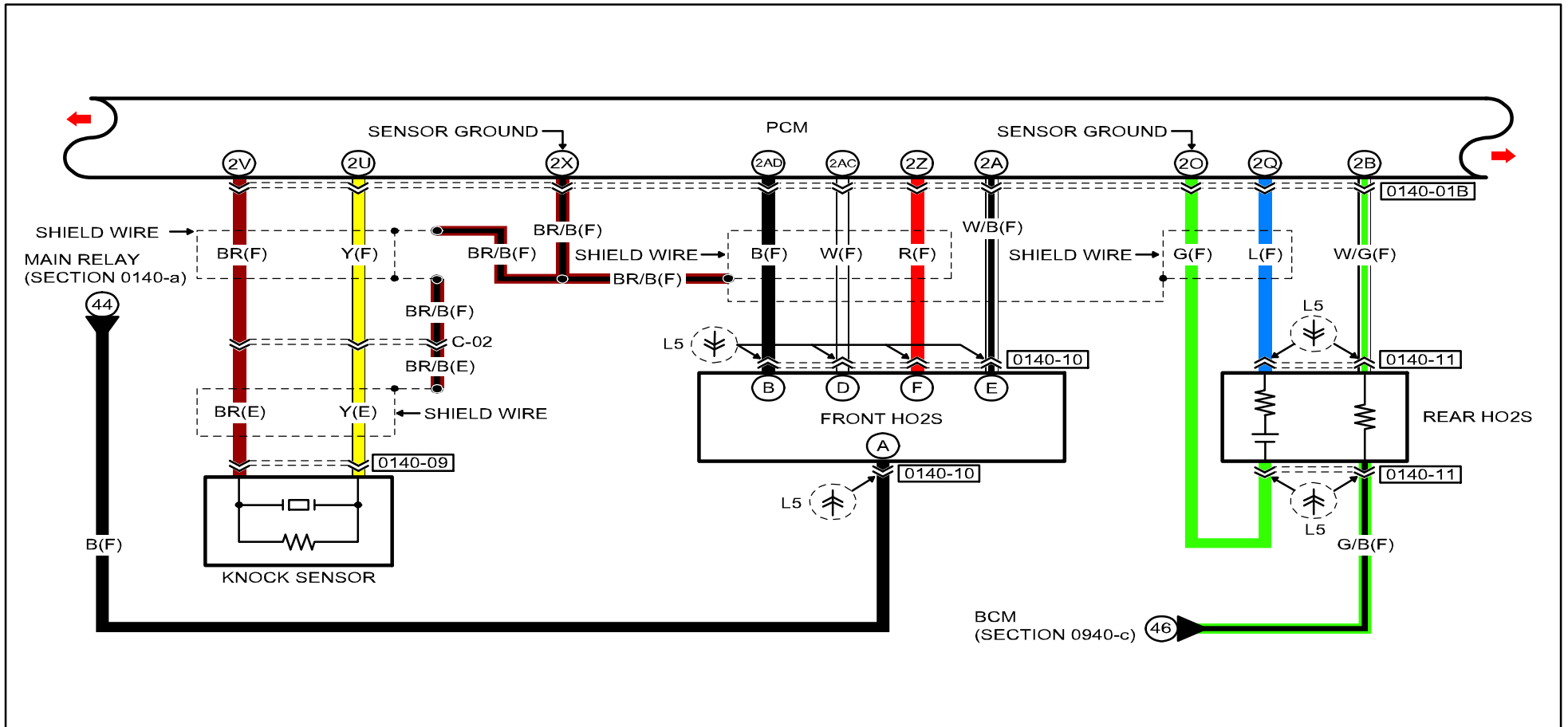

0140-01B
PCM

2BE	2BA	2AW	2AS	2AO	2AK	2AG	2AC	2Y	2U	2Q	2M	2I	2E	2A
2BF	2BB	2AX	2AT	2AP	2AL	2AH	2AD	2Z	2V	2R	2N	2J	2F	2B

EXCEPT L8

2BG	2BC	2AY	2AU	2AQ	2AM	2AI	2AE	2AA	2W	2S	2O	2K	2G	2C
2BH	2BD	2AZ	2AV	2AR	2AN	2AJ	2AF	2AB	2X	2T	2P	2L	2H	2D

0140-09
KNOCK SENSOR

0140-10
FRONT HO2S

(EXCEPT L5)

(L5)

0140-11
REAR HO2S

(EXCEPT L5)

(L5)

CONTROL SYSTEM (EXCEPT MZR-CD (RF Turbo))

0140-e

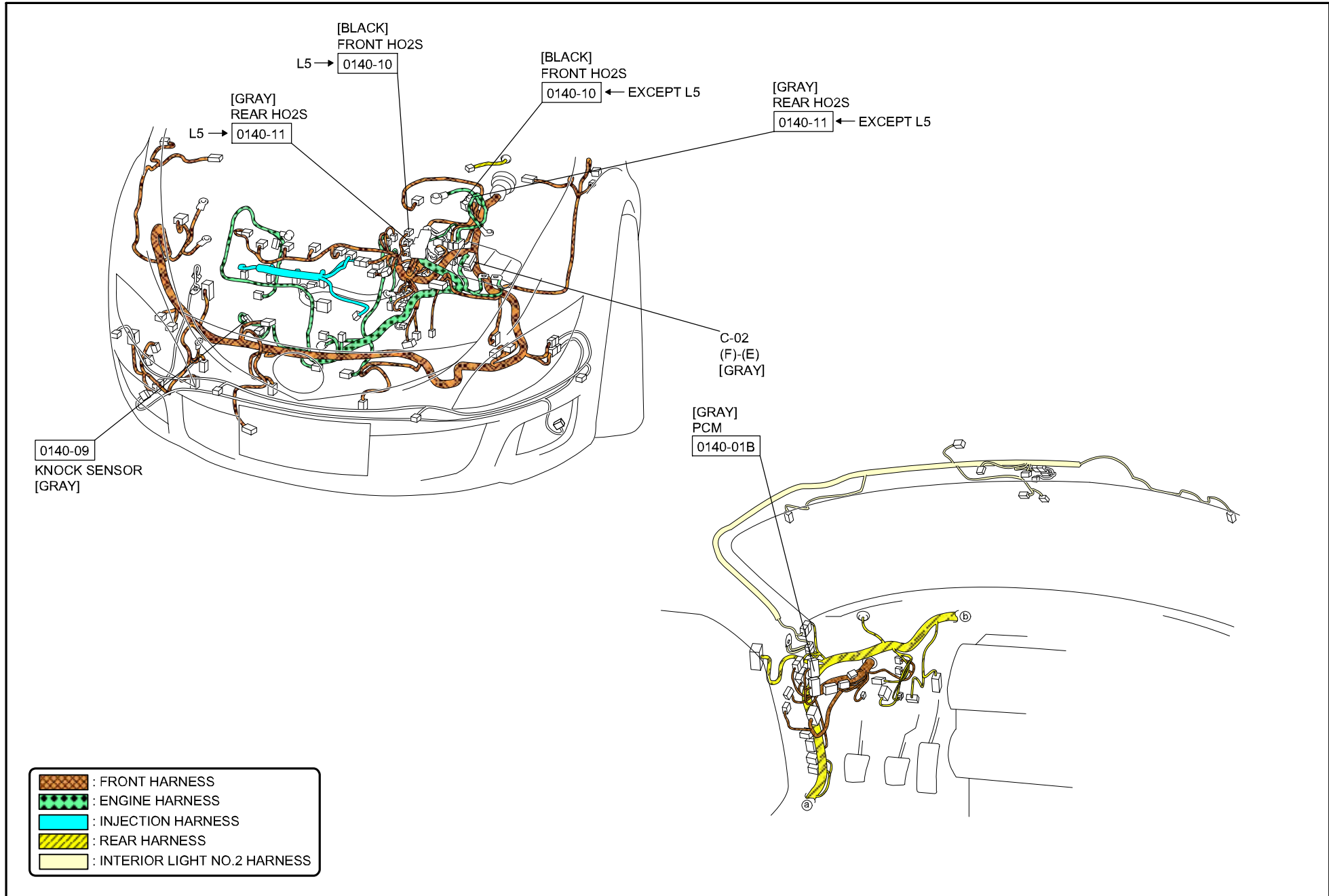

C-02

FRONT HARNESS-ENGINE HARNESS

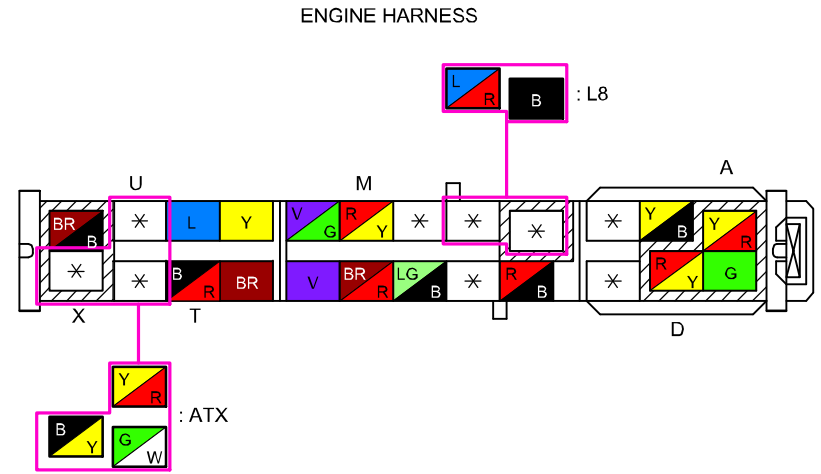
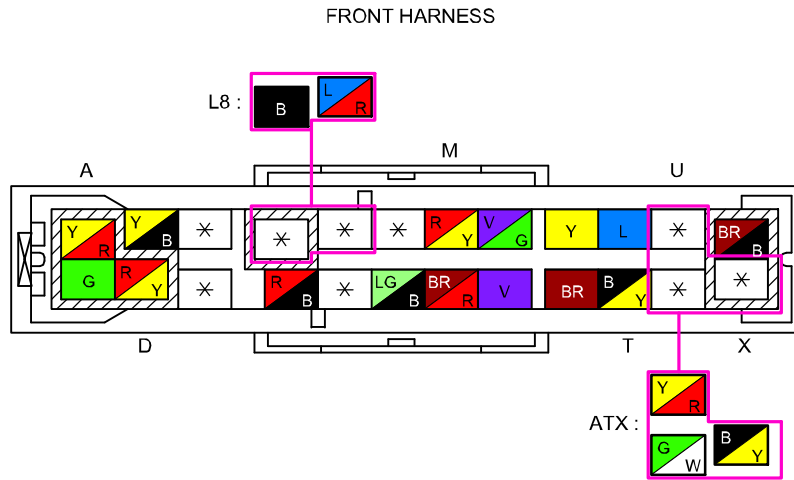

(EXCEPT MZR-CD (RF Turbo))

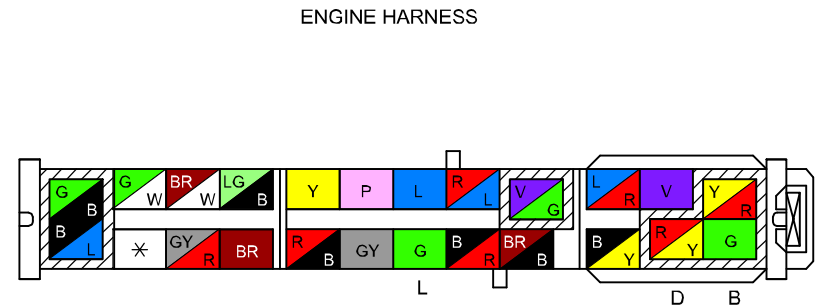
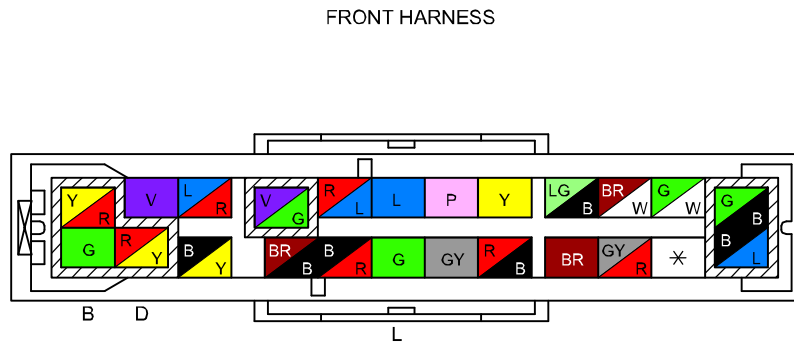

(MZR-CD (RF Turbo))

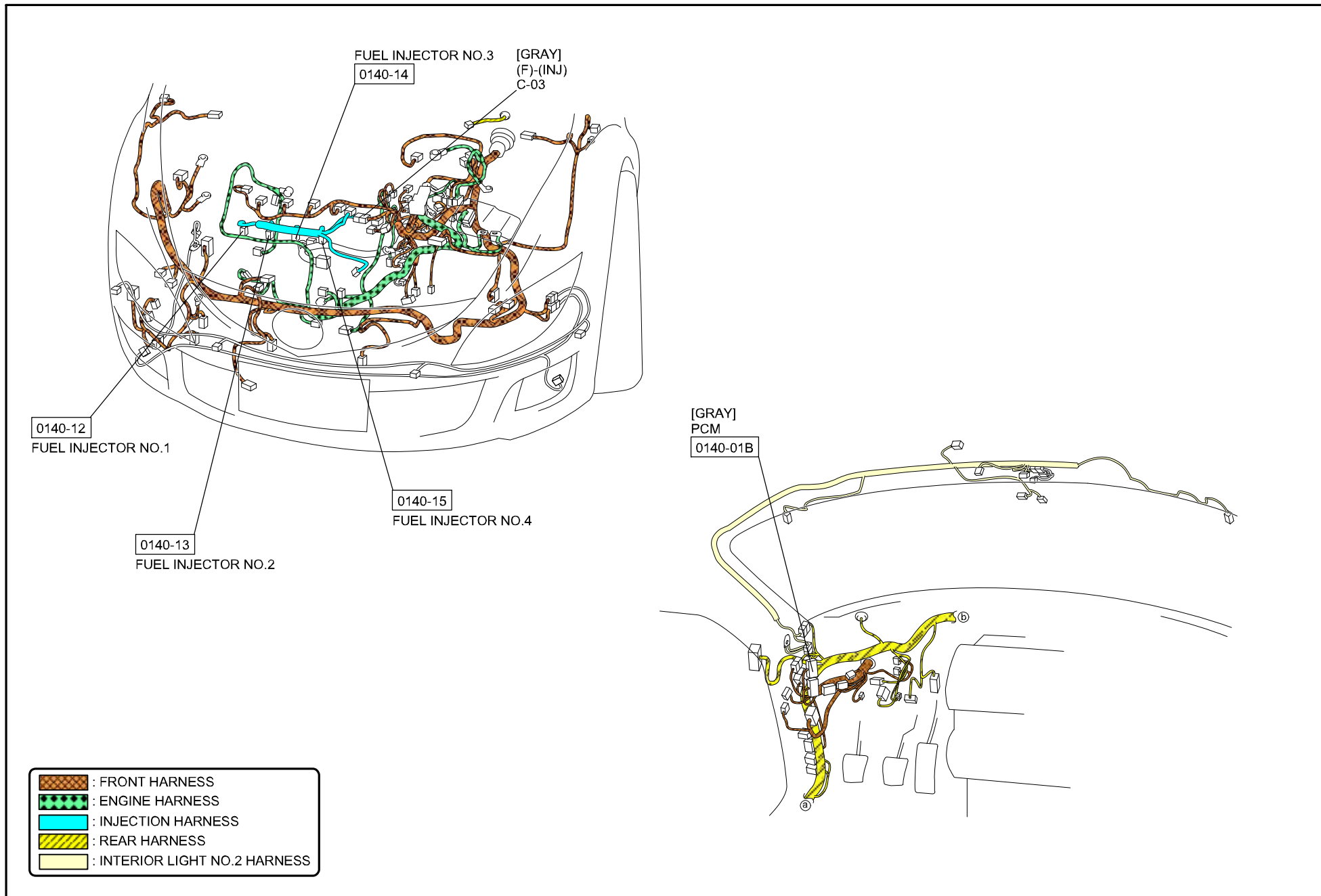

C-03

FRONT HARNESS-INJECTION HARNESS

FRONT HARNESS

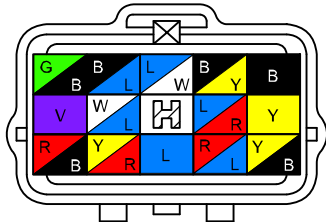

INJECTION HARNESS

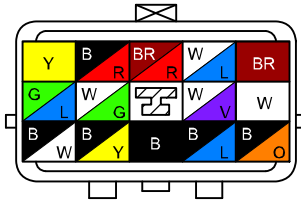

(EXCEPT MZR-CD (RF Turbo))

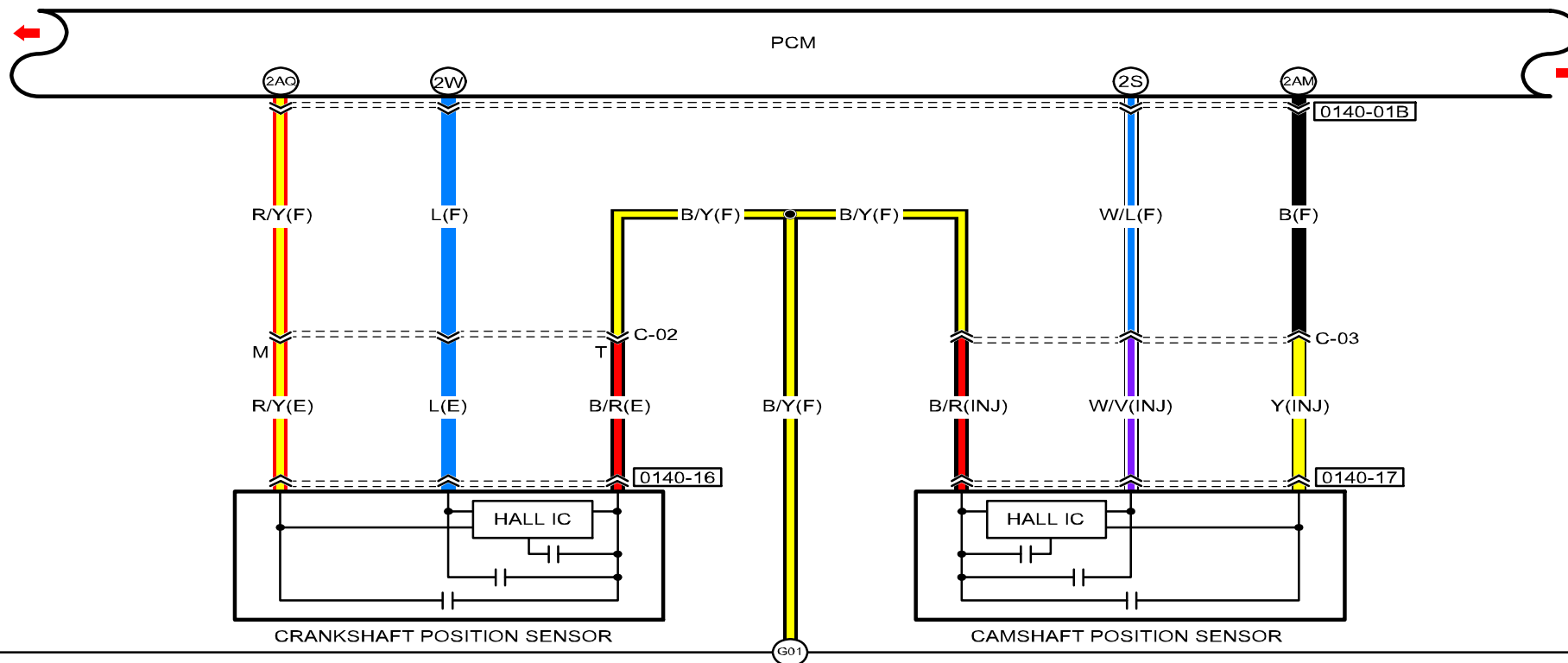

0140-01B
PCM

2BE 2BA 2AW 2AS 2AO 2AK 2AG 2AC 2Y 2U 2Q 2M 2I 2E 2A
2BF 2BB 2AX 2AT 2AP 2AL 2AH 2AD 2Z 2V 2R 2N 2J 2F 2B

B Y : EXCEPT L8

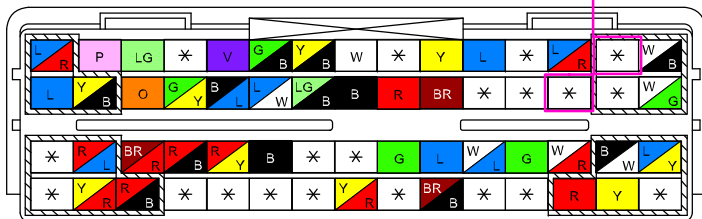

2BG 2BC 2AY 2AU 2AQ 2AM 2AI 2AE 2AA 2W 2S 2O 2K 2G 2C
2BH 2BD 2AZ 2AV 2AR 2AN 2AJ 2AF 2AB 2X 2T 2P 2L 2H 2D

0140-16
CRANKSHAFT POSITION SENSOR

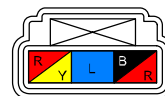

0140-17
CAMSHAFT POSITION SENSOR

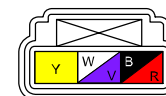

CONTROL SYSTEM (EXCEPT MZR-CD (RF Turbo))

0140-g

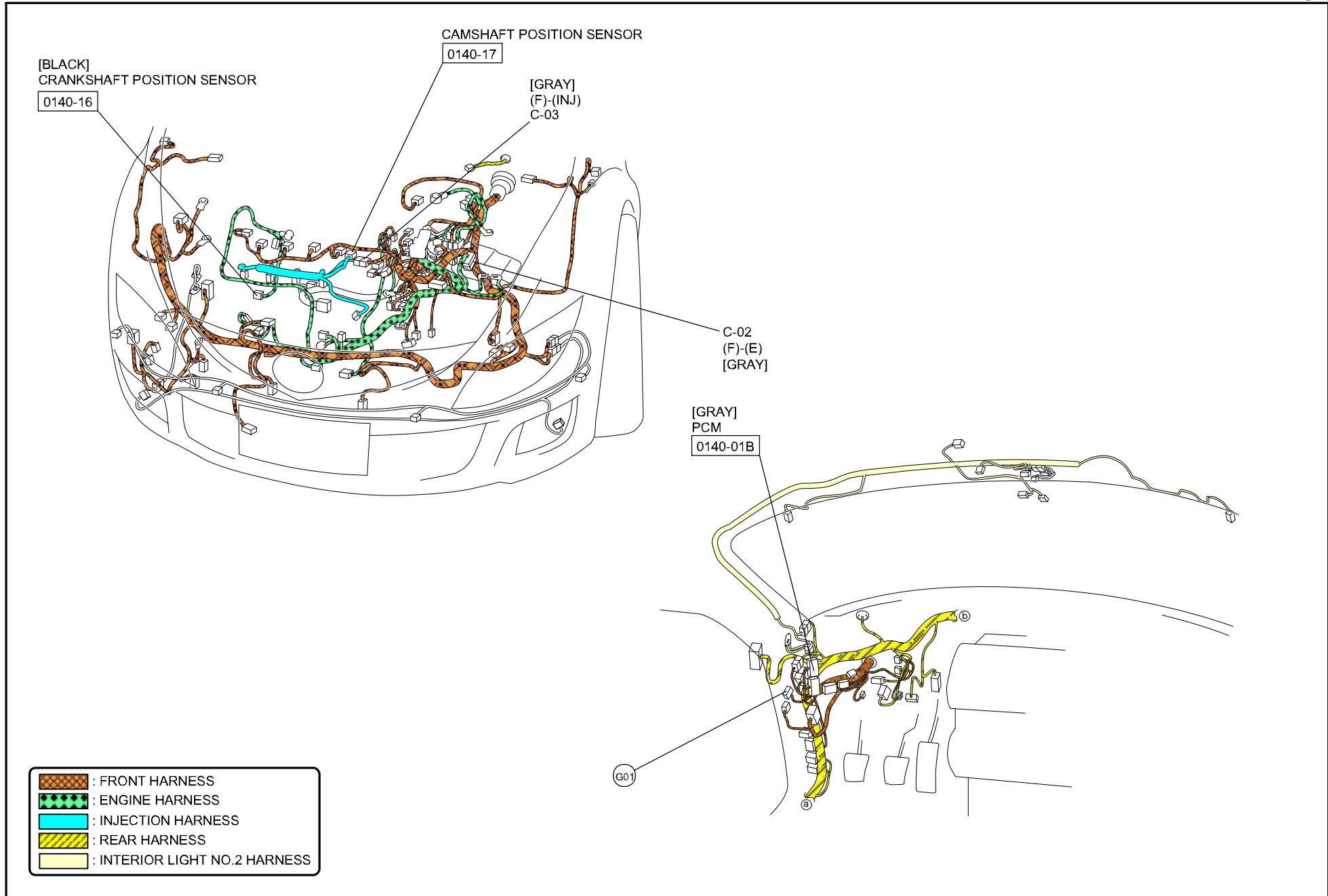

C-03

FRONT HARNESS-INJECTION HARNESS

FRONT HARNESS

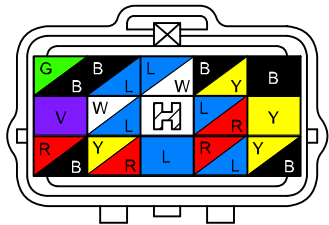

INJECTION HARNESS

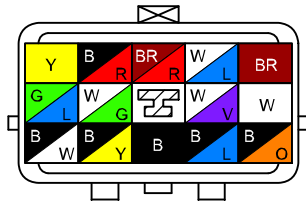

(EXCEPT MZR-CD (RF Turbo))

CONTROL SYSTEM (EXCEPT MZR-CD (RF Turbo))

0140-h

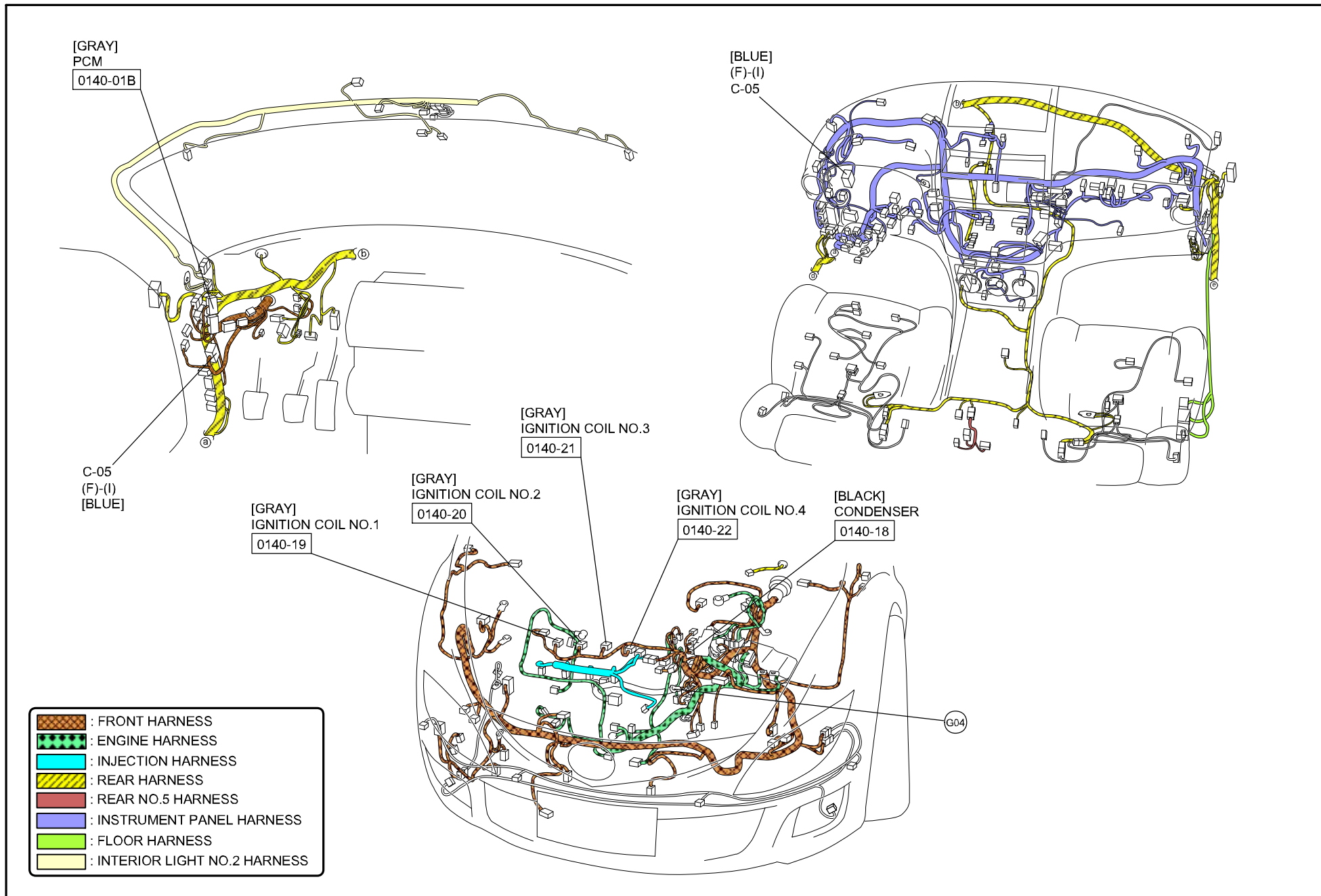

C-05

FRONT HARNESS-INSTRUMENT PANEL HARNESS

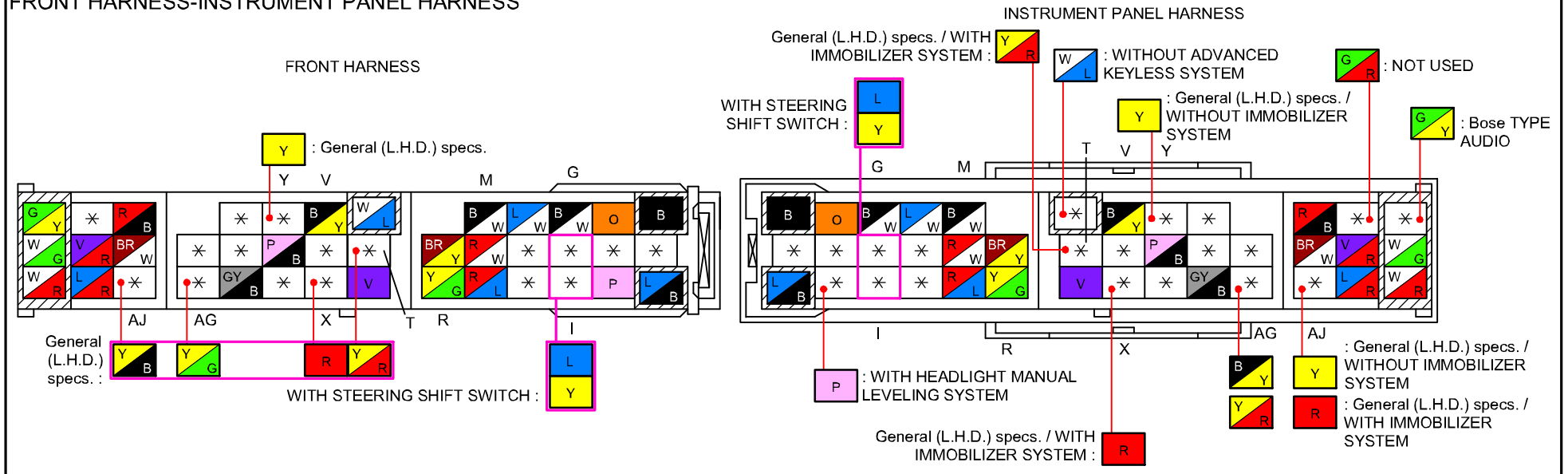

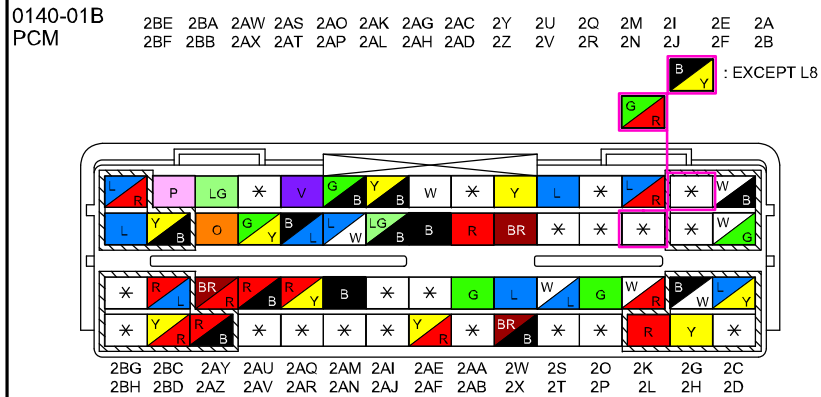
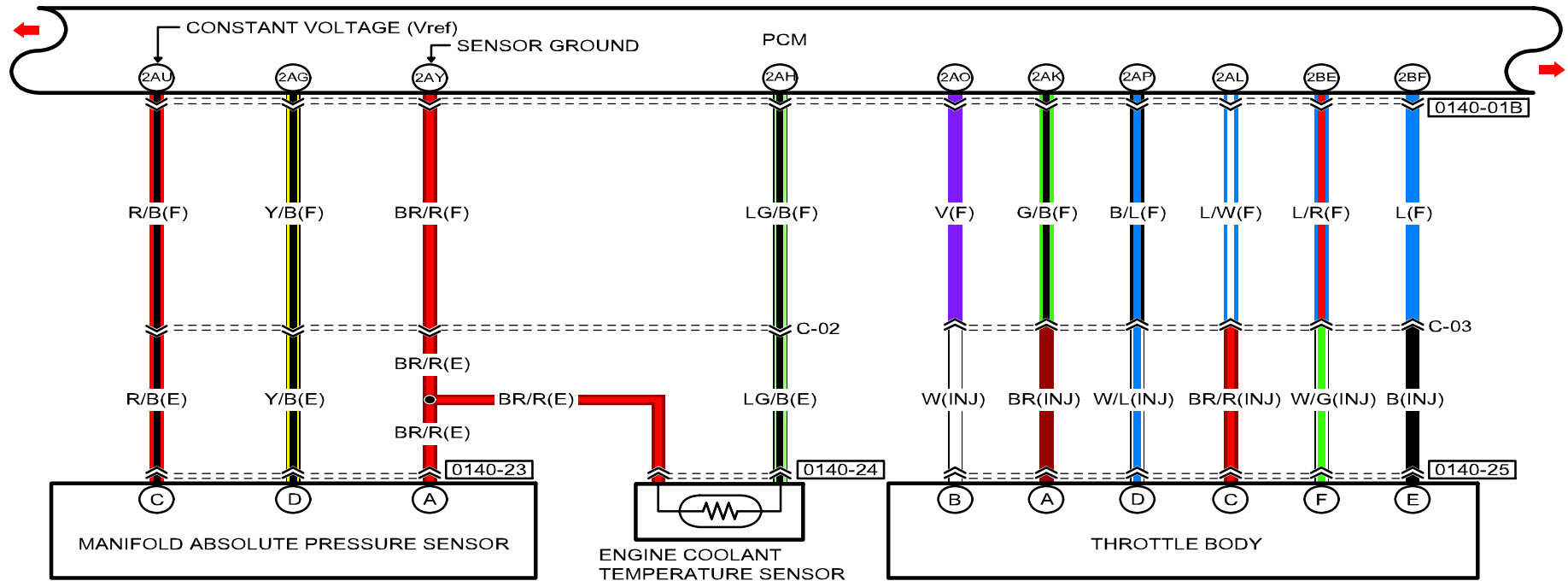

0140-23
MANIFOLD ABSOLUTE
PRESSURE SENSOR

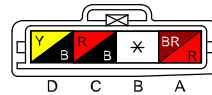

0140-24
ENGINE COOLANT
TEMPERATURE SENSOR

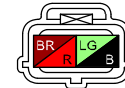

0140-25
THROTTLE BODY

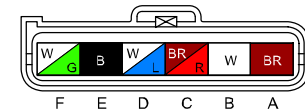

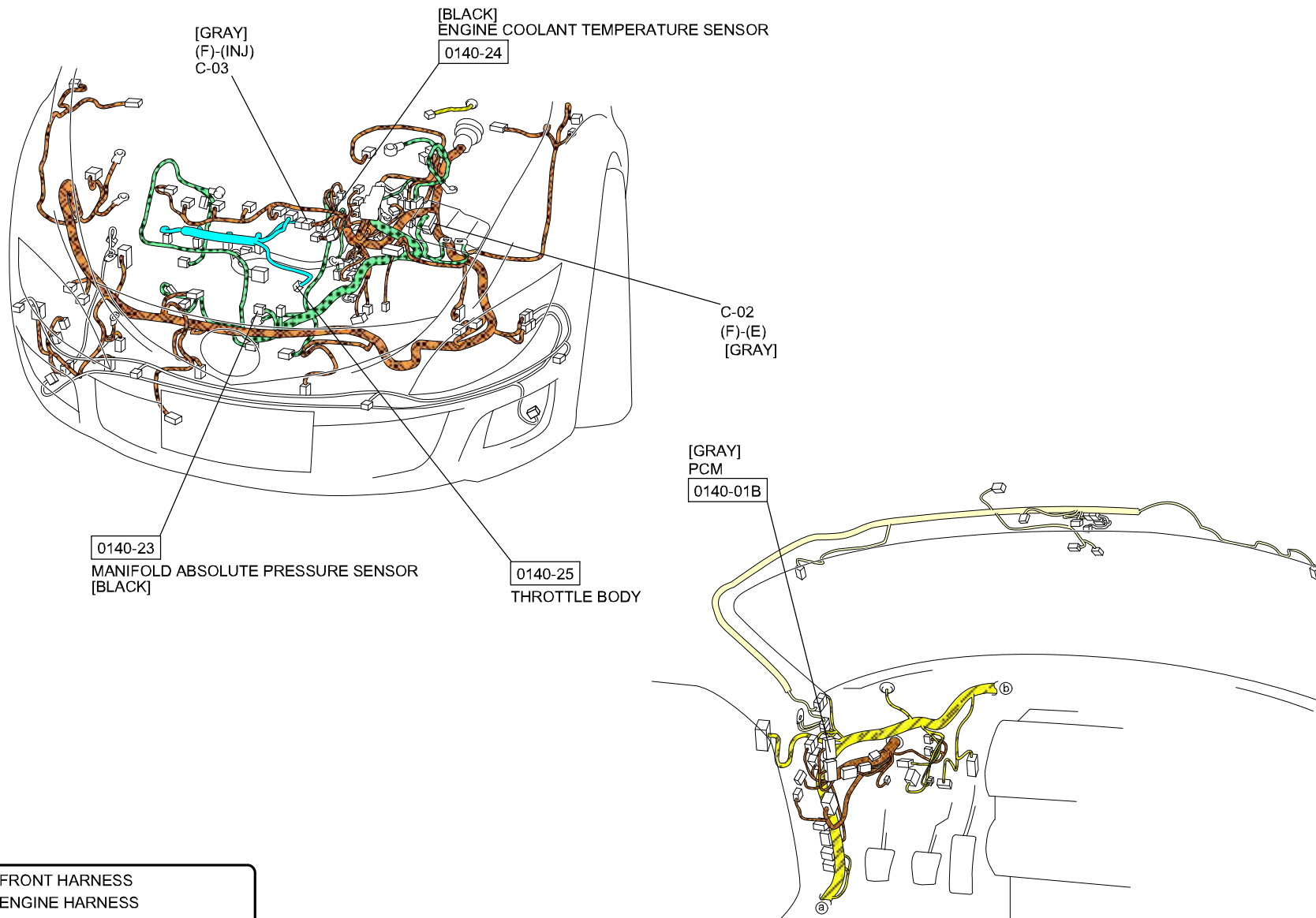

- : FRONT HARNESS
- : ENGINE HARNESS
- : INJECTION HARNESS
- : REAR HARNESS
- : INTERIOR LIGHT NO.2 HARNESS

C-02

FRONT HARNESS-ENGINE HARNESS

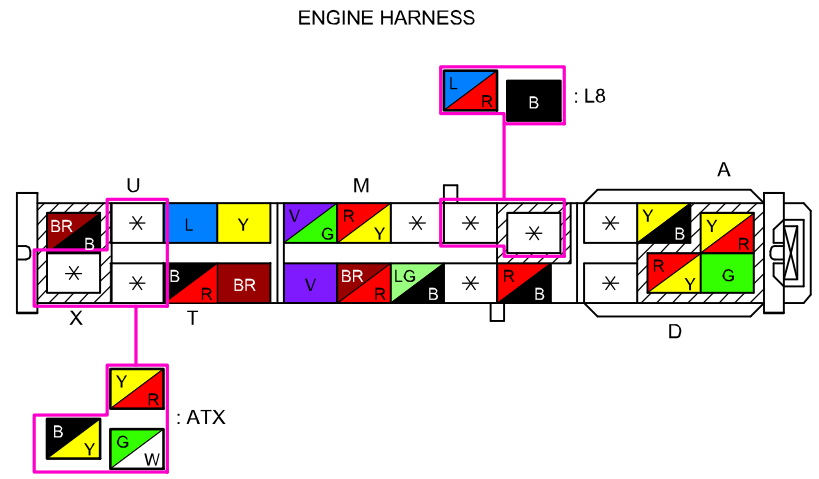
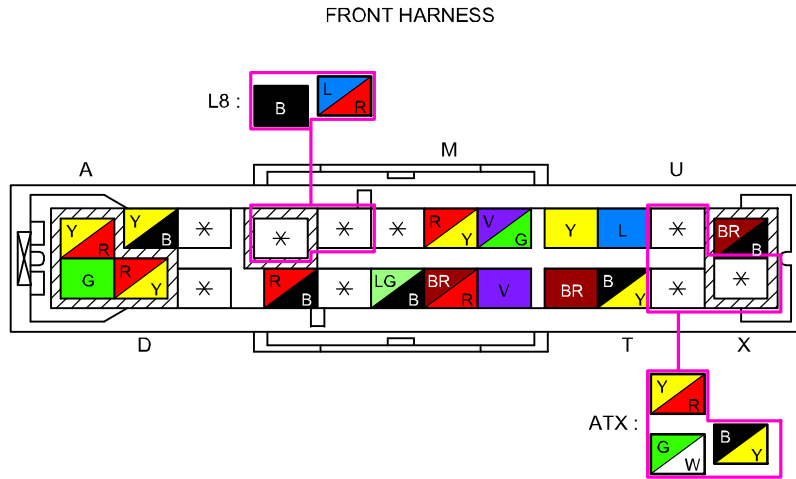

(EXCEPT MZR-CD (RF Turbo))

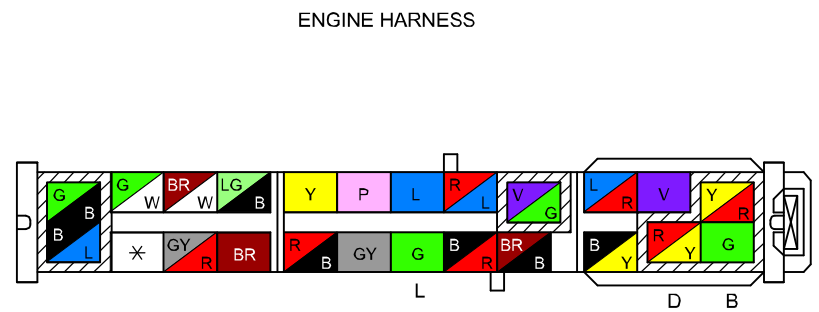
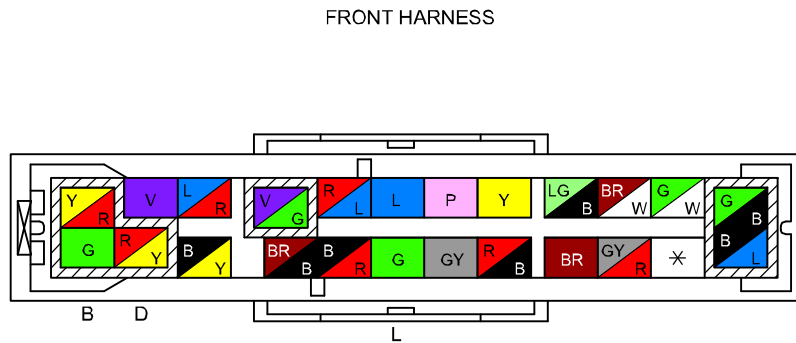

(MZR-CD (RF Turbo))

C-03

FRONT HARNESS-INJECTION HARNESS

FRONT HARNESS

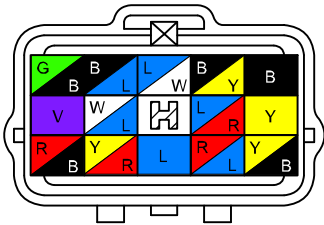

INJECTION HARNESS

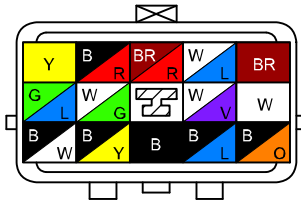

(EXCEPT MZR-CD (RF Turbo))

@2 : WITH ADVANCED KEYLESS SYSTEM

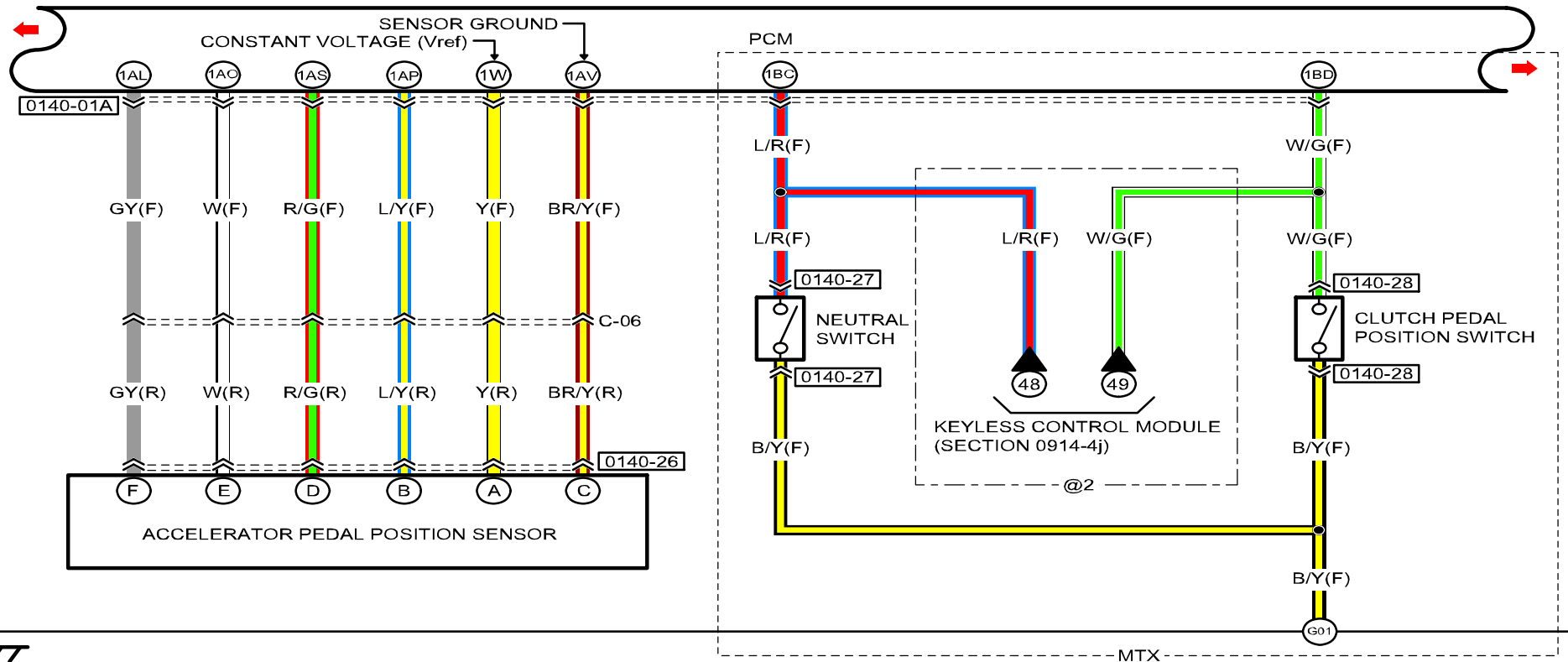

0140-01A
PCM

1BE 1BA 1AW 1AS 1AO 1AK 1AG 1AC 1Y 1U 1Q 1M 1I 1E 1A
1BF 1BB 1AX 1AT 1AP 1AL 1AH 1AD 1Z 1V 1R 1N 1J 1F 1B

R : General (L.H.D.) specs.
B : FOR INTENSELY HOT AREA, L5, General (L.H.D.) specs.
W : WITH TWO COOLING FAN RELAYS, WITH FOUR COOLING FAN RELAYS
L : WITH THREE COOLING FAN RELAYS, WITH FOUR COOLING FAN RELAYS

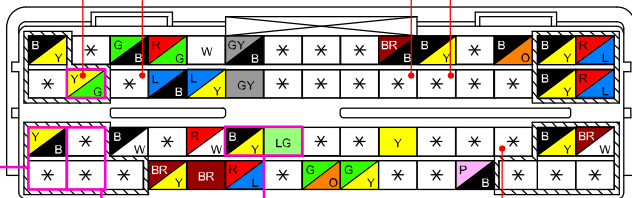

R : General (L.H.D.) specs.
Y : General (L.H.D.) specs.

R : MTX
G : L5

G : ATX / EXCEPT TAIWAN
R : ATX / EXCEPT TAIWAN

1BG 1BC 1AY 1AU 1AQ 1AM 1AI 1AE 1AA 1W 1S 1O 1K 1G 1C
1BH 1BD 1AZ 1AV 1AR 1AN 1AJ 1AF 1AB 1X 1T 1P 1L 1H 1D

0140-26
ACCELERATOR PEDAL POSITION SENSOR

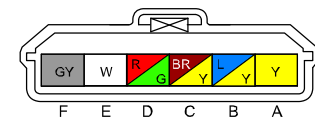

0140-27
NEUTRAL SWITCH

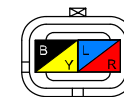

0140-28
CLUTCH PEDAL POSITION SWITCH

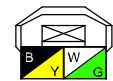

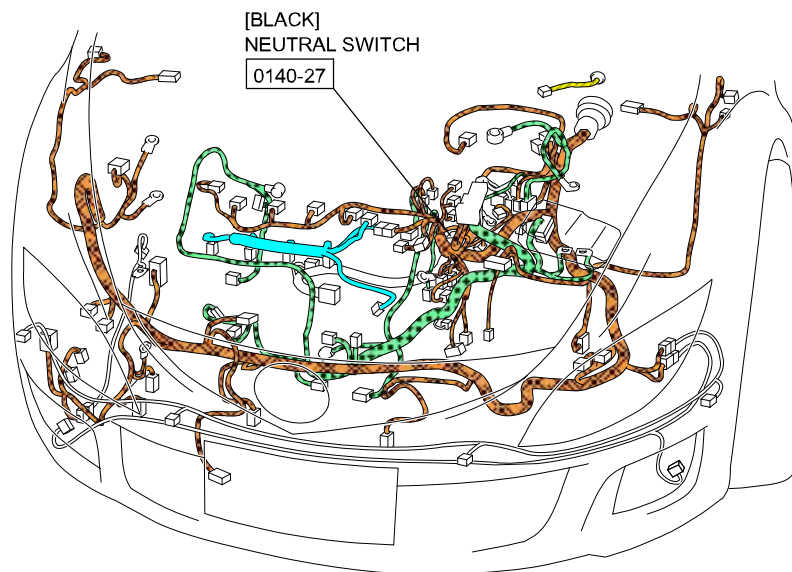

- : FRONT HARNESS
- : ENGINE HARNESS
- : INJECTION HARNESS
- : REAR HARNESS
- : INTERIOR LIGHT NO.2 HARNESS

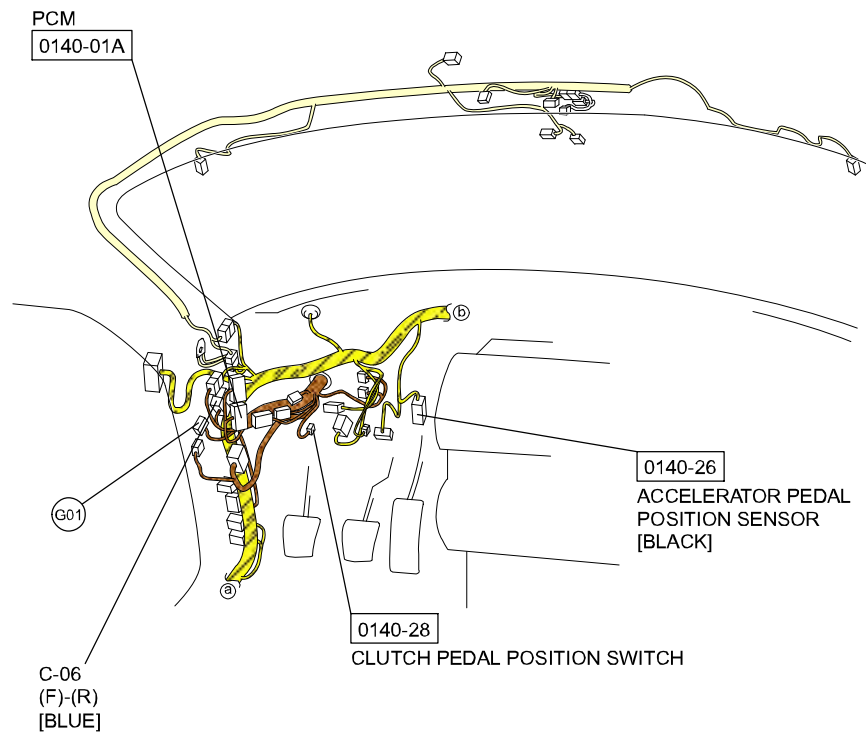





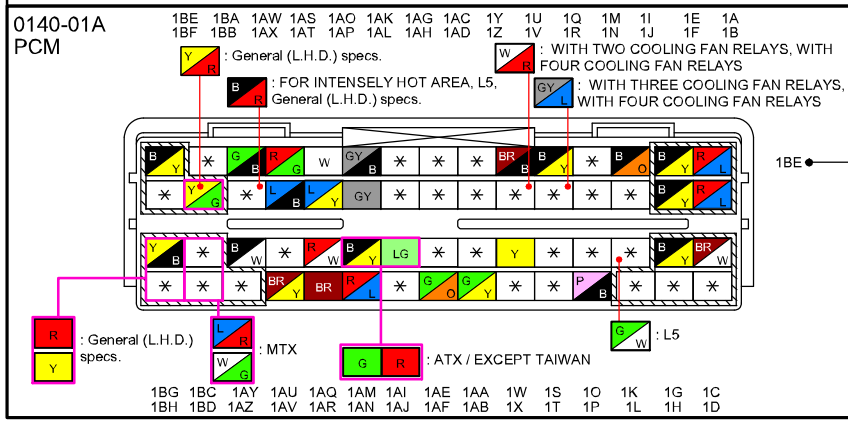
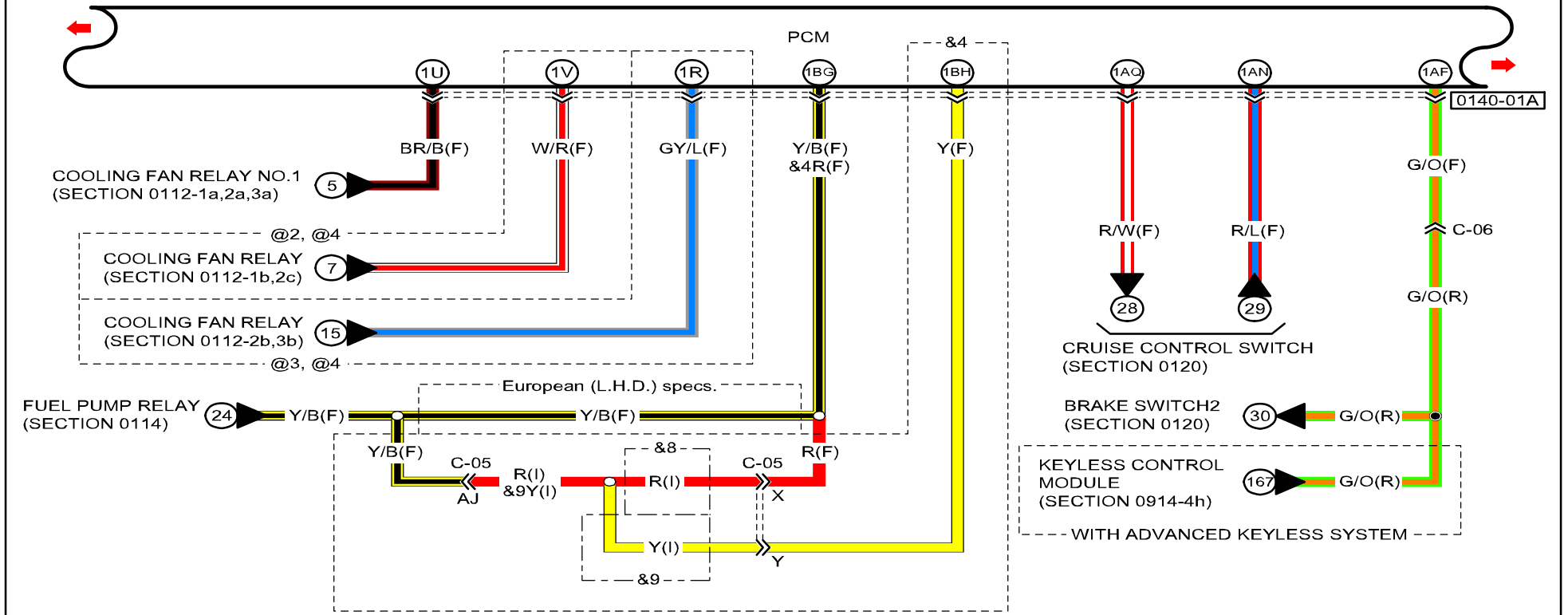

CONTROL SYSTEM (EXCEPT MZR-CD (RF Turbo))

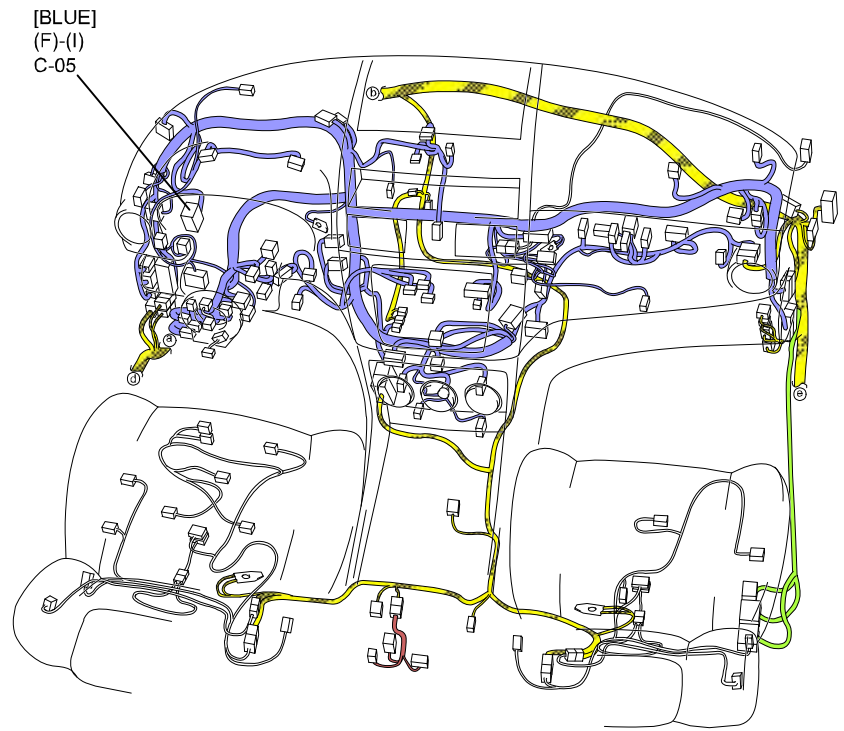
0140-k

- @2 : WITH TWO COOLING FAN RELAYS
- @3 : WITH THREE COOLING FAN RELAYS
- @4 : WITH FOUR COOLING FAN RELAYS
- @9 : FOR INTENSELY HOT AREA
- &4 : General (L.H.D.) specs.
- &8 : WITH IMMOBILIZER SYSTEM
- &9 : WITHOUT IMMOBILIZER SYSTEM





-  : FRONT HARNESS
-  : REAR HARNESS
-  : REAR NO.5 HARNESS
-  : INSTRUMENT PANEL HARNESS
-  : FLOOR HARNESS
-  : INTERIOR LIGHT NO.2 HARNESS

CONTROL SYSTEM (EXCEPT MZR-CD (RF Turbo))

0140-I

@ : ATX / EXCEPT TAIWAN
 @9 : FOR INTENSELY HOT AREA
 &4 : General (L.H.D.) specs.

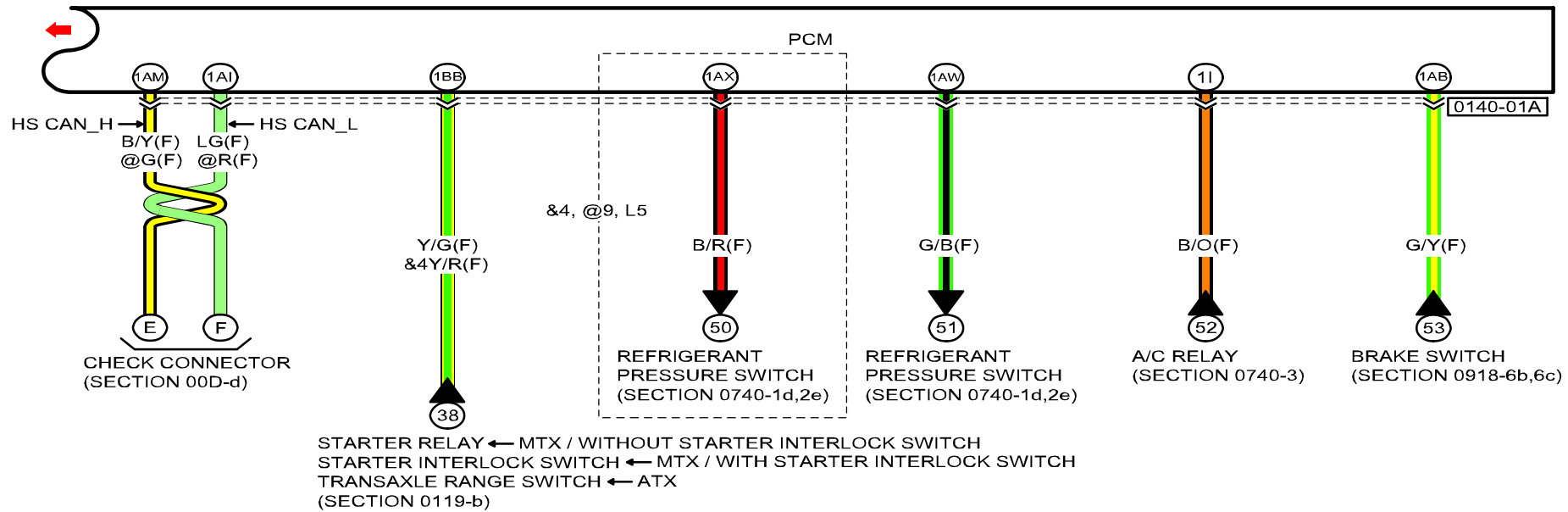

0140-01A PCM

1BE 1BA 1AW 1AS 1AO 1AK 1AG 1AC 1Y 1U 1Q 1M 1I 1E 1A
 1BF 1BB 1AX 1AT 1AP 1AL 1AH 1AD 1Z 1V 1R 1N 1J 1F 1B

Y R : General (L.H.D.) specs.
 W : WITH TWO COOLING FAN RELAYS, WITH FOUR COOLING FAN RELAYS
 B R : FOR INTENSELY HOT AREA, L5, General (L.H.D.) specs.
 G Y L : WITH THREE COOLING FAN RELAYS, WITH FOUR COOLING FAN RELAYS

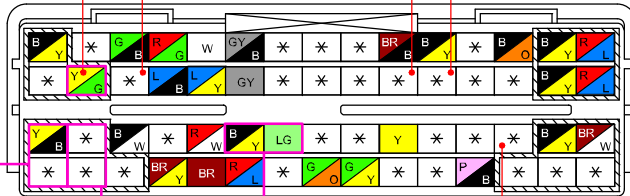



R : General (L.H.D.) specs.
 Y : General (L.H.D.) specs.
 L R : MTX
 W : MTX
 G R : ATX / EXCEPT TAIWAN
 G W : L5

1BG 1BC 1AY 1AU 1AQ 1AM 1AI 1AE 1AA 1W 1S 1O 1K 1G 1C
 1BH 1BD 1AZ 1AV 1AR 1AN 1AJ 1AF 1AB 1X 1T 1P 1L 1H 1D





-  : FRONT HARNESS
-  : REAR HARNESS
-  : INTERIOR LIGHT NO.2 HARNESS

CONTROL SYSTEM (MZR-CD (RF Turbo))

0140-2a

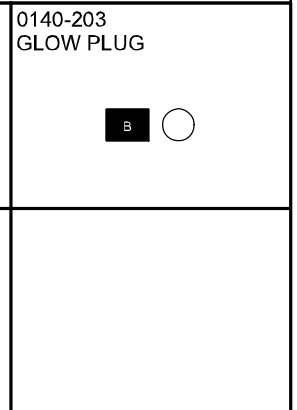
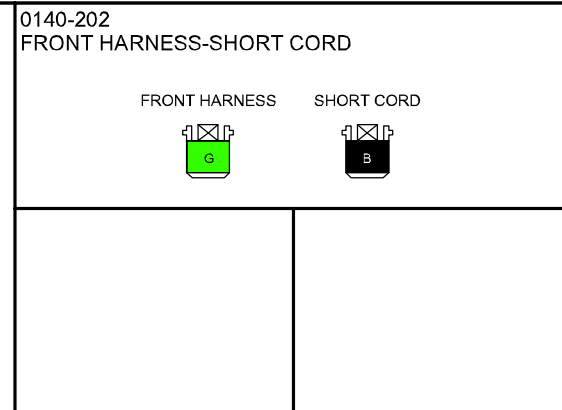
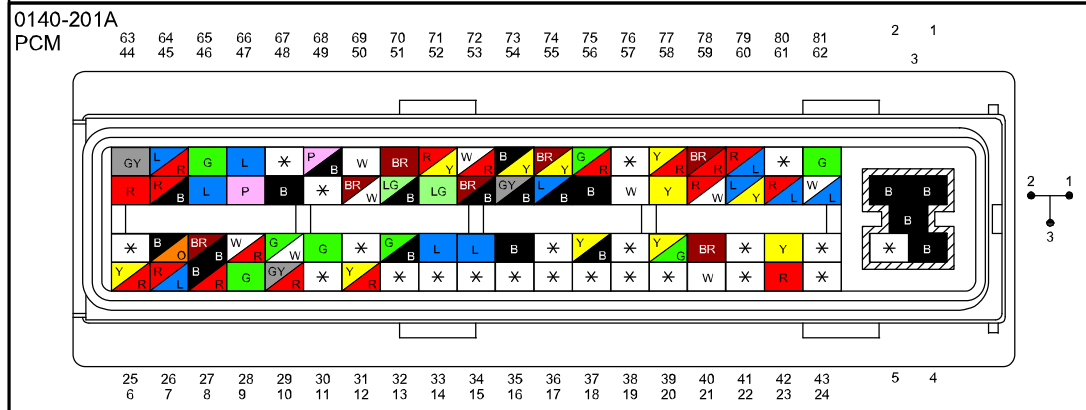
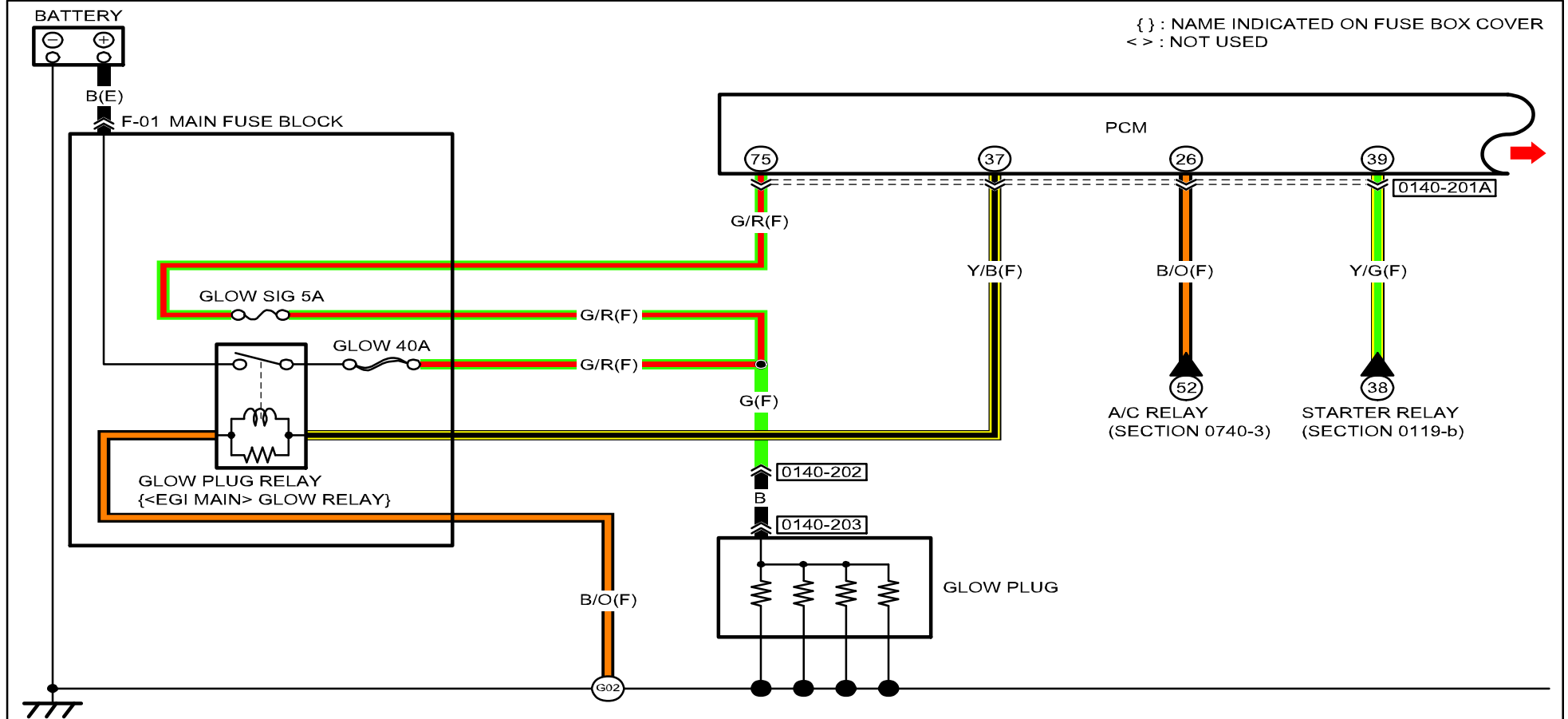

CONTROL SYSTEM (MZR-CD (RF Turbo))

0140-2a

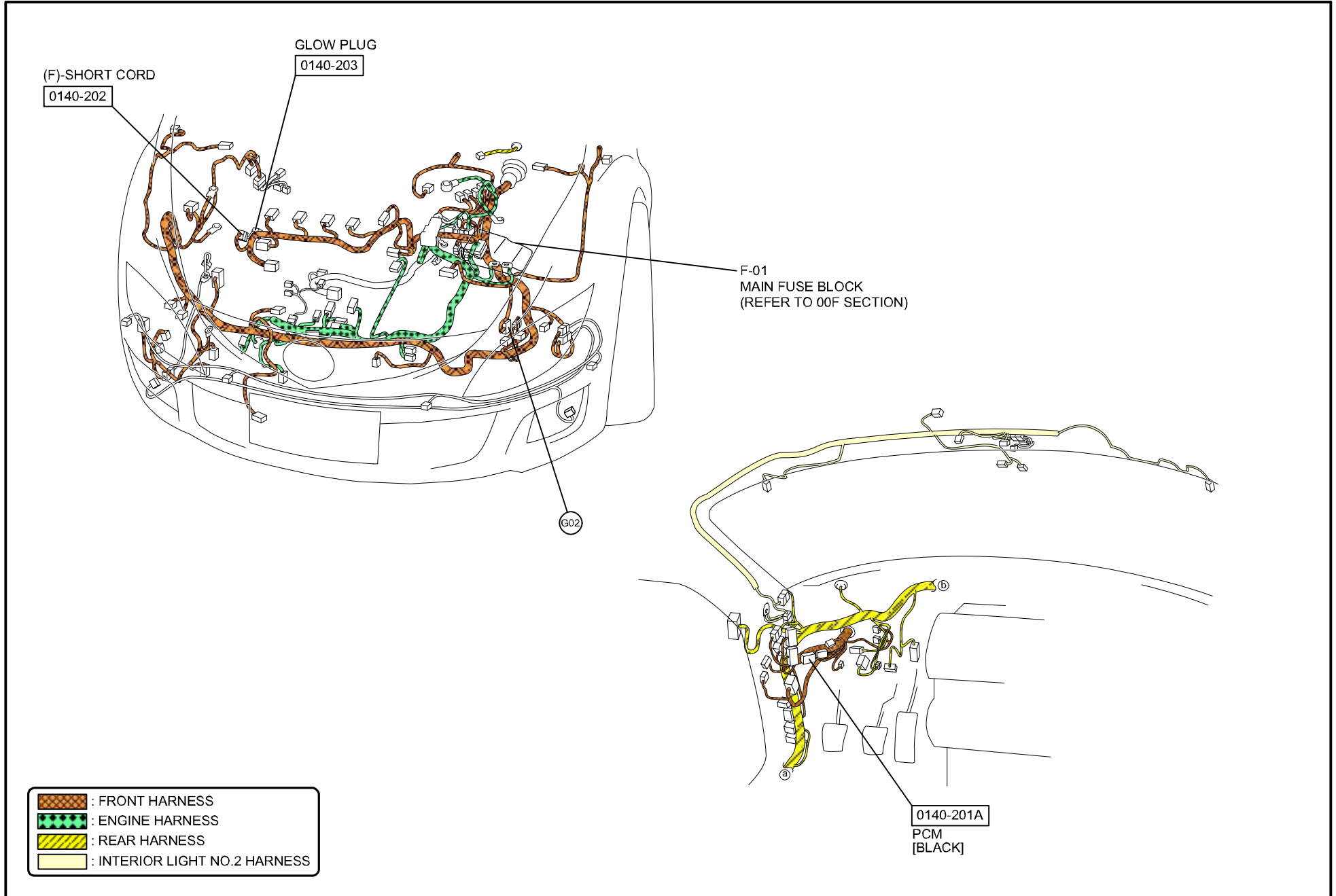

CONTROL SYSTEM (MZR-CD (RF Turbo))

0140-2b

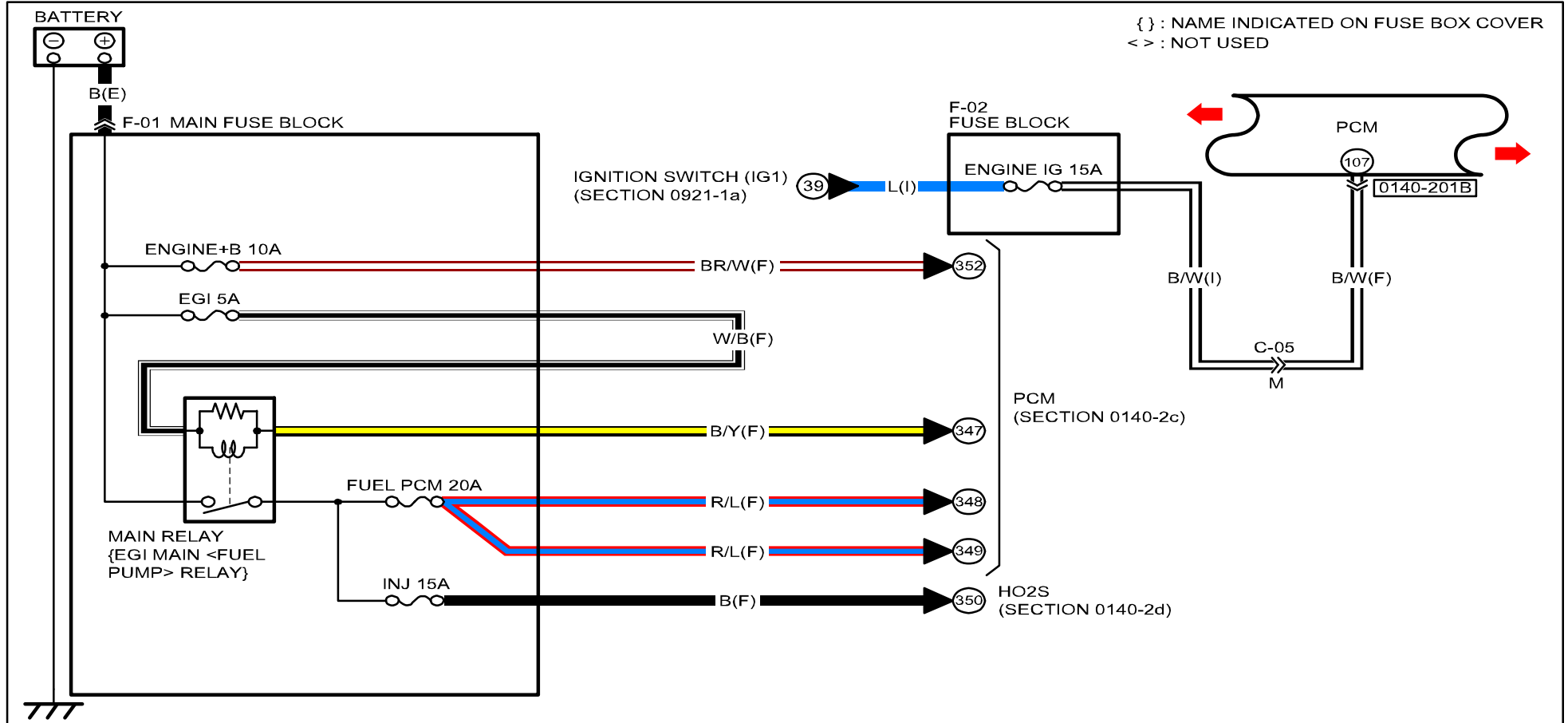

0140-201B
PCM

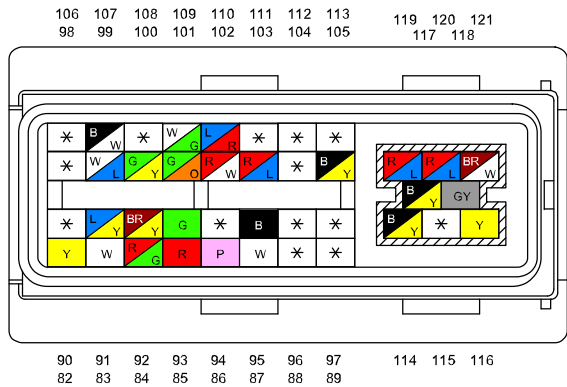

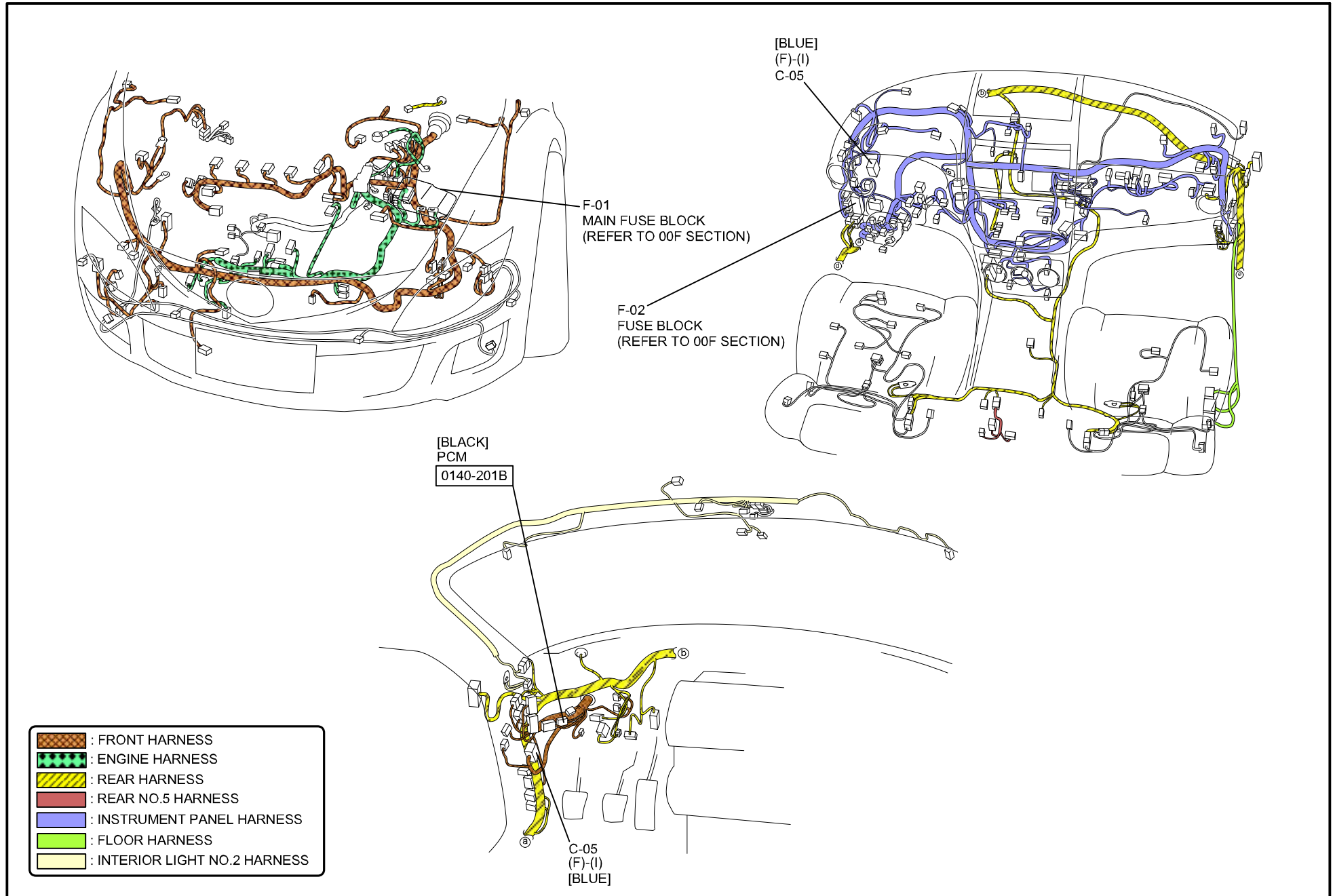

C-05

FRONT HARNESS-INSTRUMENT PANEL HARNESS

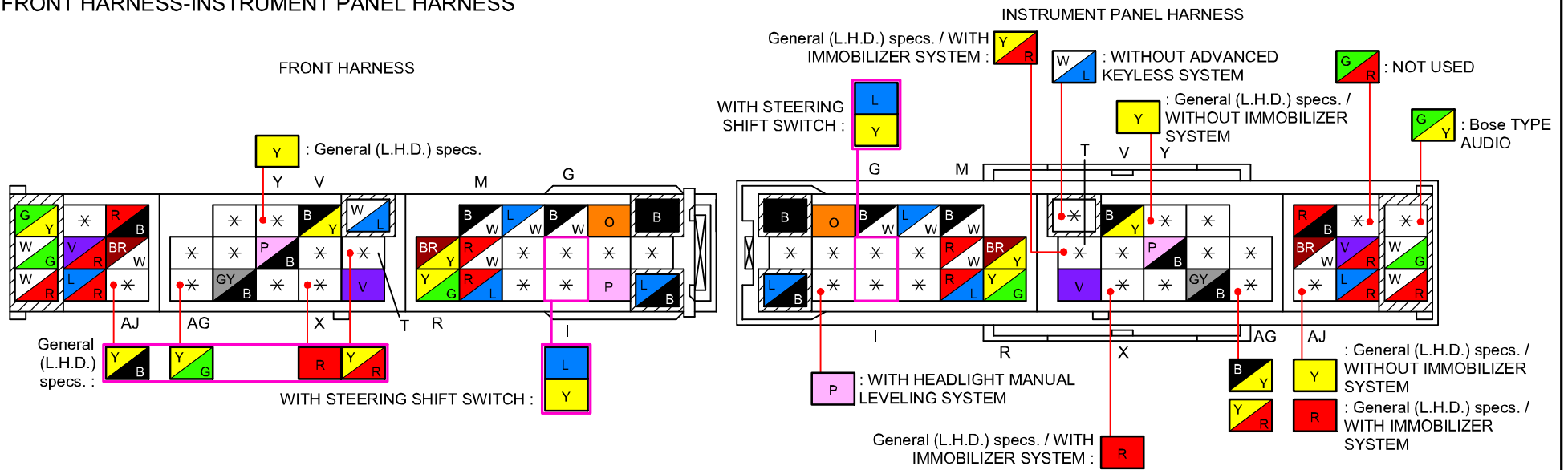

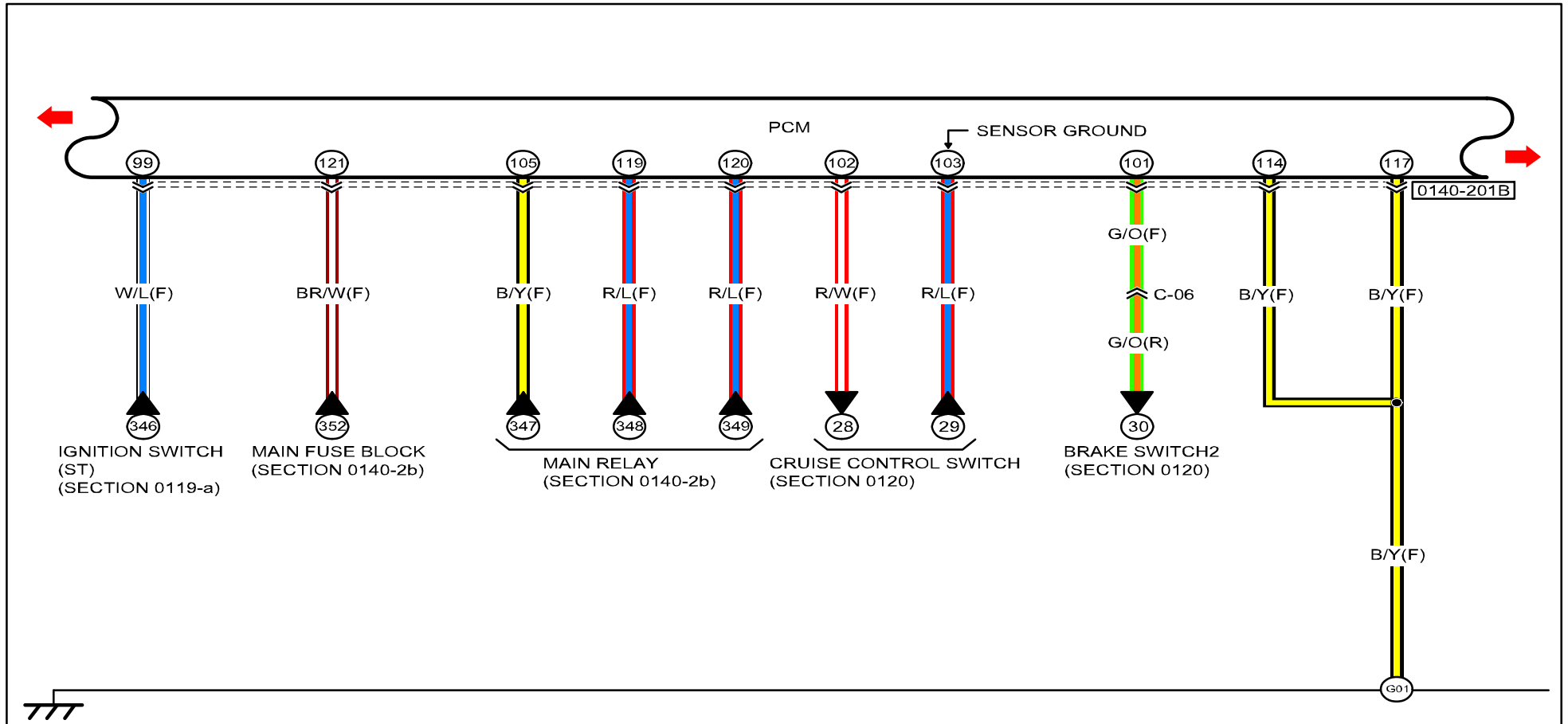

<p>0140-201B PCM</p>	106 107 108 109 110 111 112 113	119 120 121			
	98 99 100 101 102 103 104 105	117 118			
	90 91 92 93 94 95 96 97	114 115 116			
	82 83 84 85 86 87 88 89				

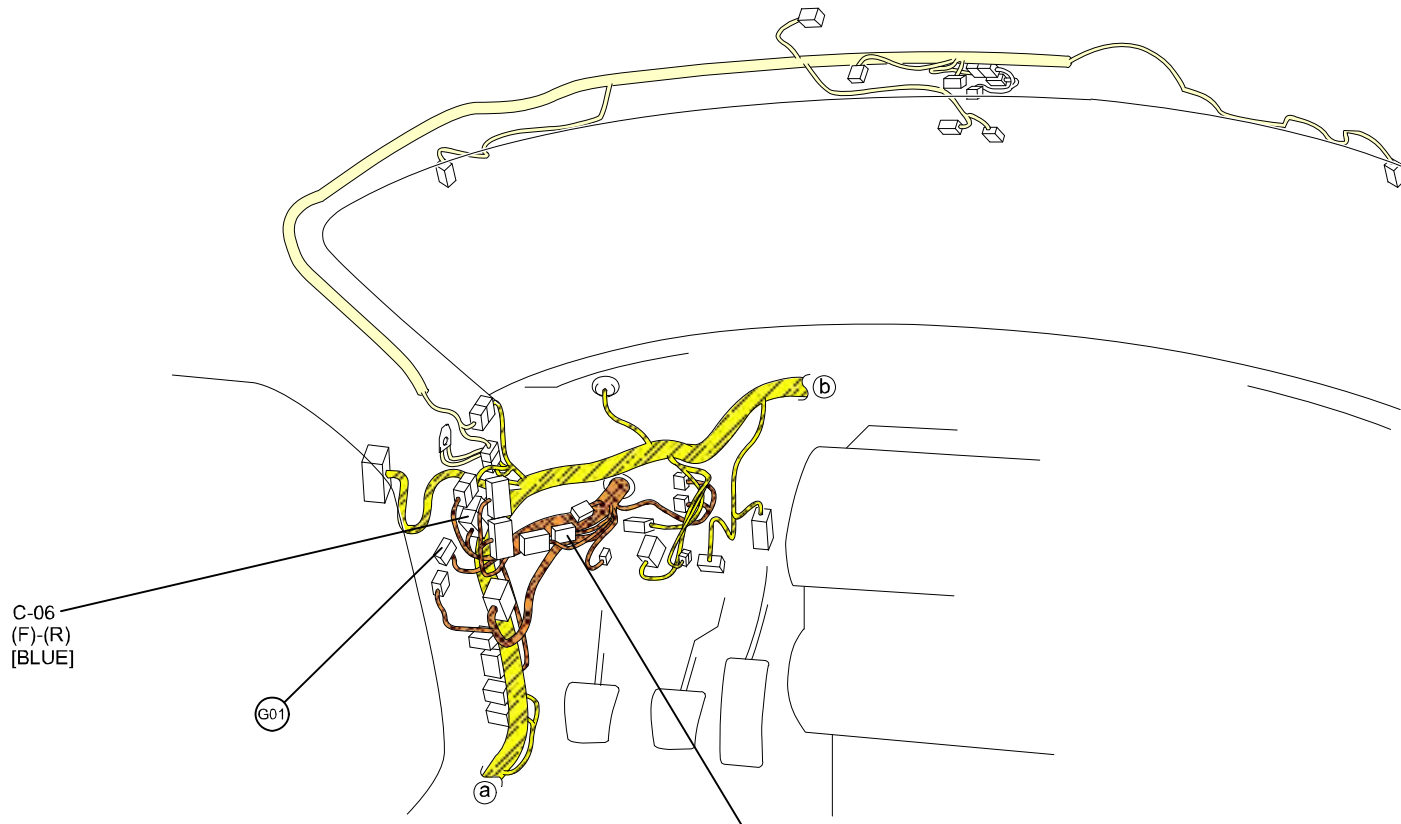



C-06
(F)-(R)
[BLUE]

G01

a

b

0140-201B
PCM
[BLACK]

-  : FRONT HARNESS
-  : REAR HARNESS
-  : INTERIOR LIGHT NO.2 HARNESS

CONTROL SYSTEM (MZR-CD (RF Turbo))

0140-2c

C-06

FRONT HARNESS-REAR HARNESS

FRONT HARNESS

REAR HARNESS

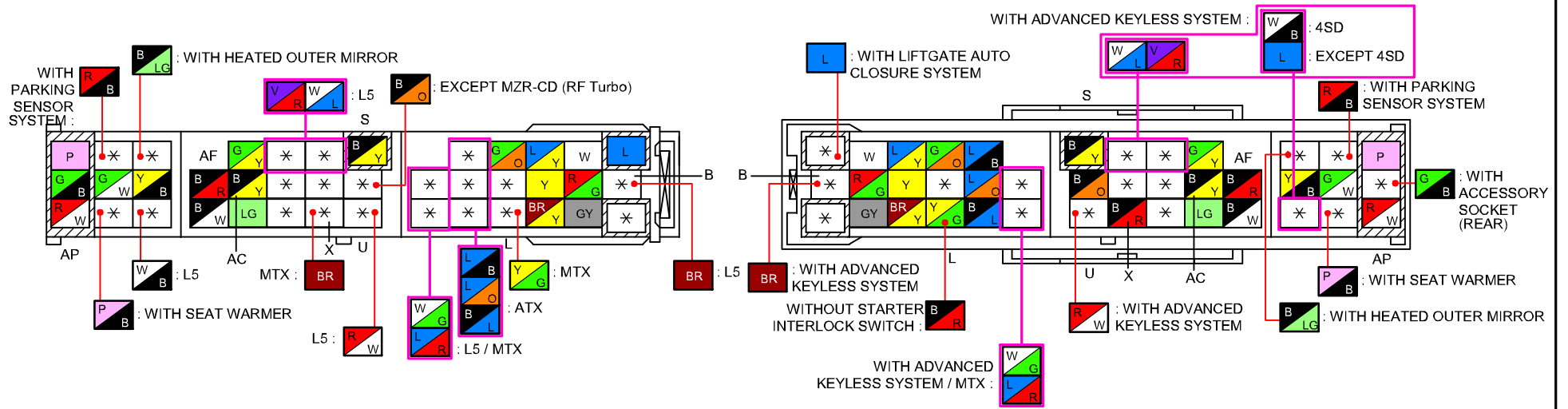

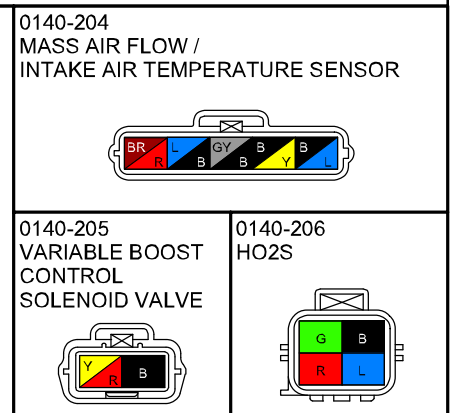
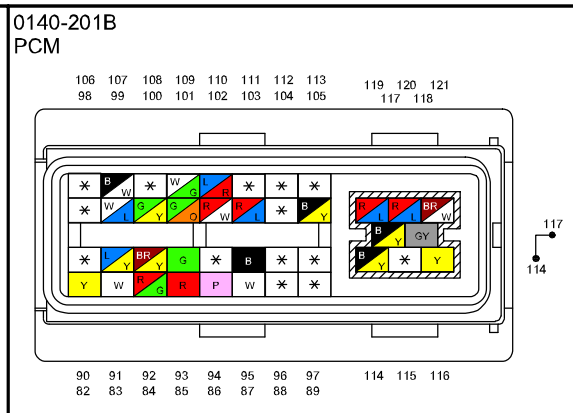
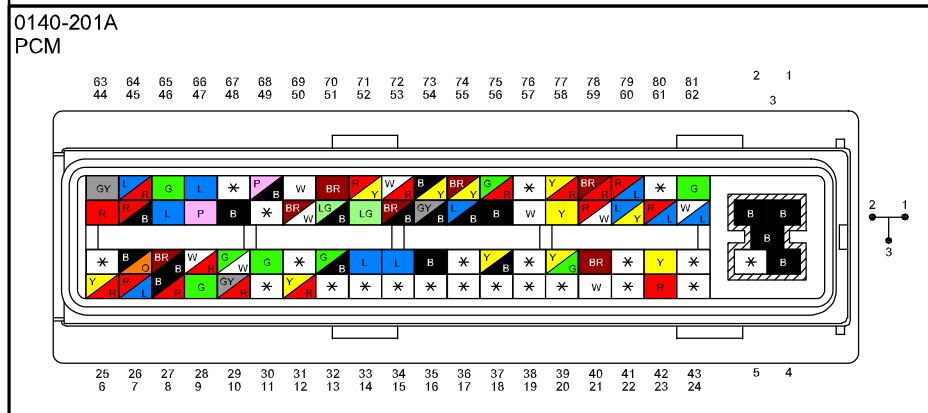
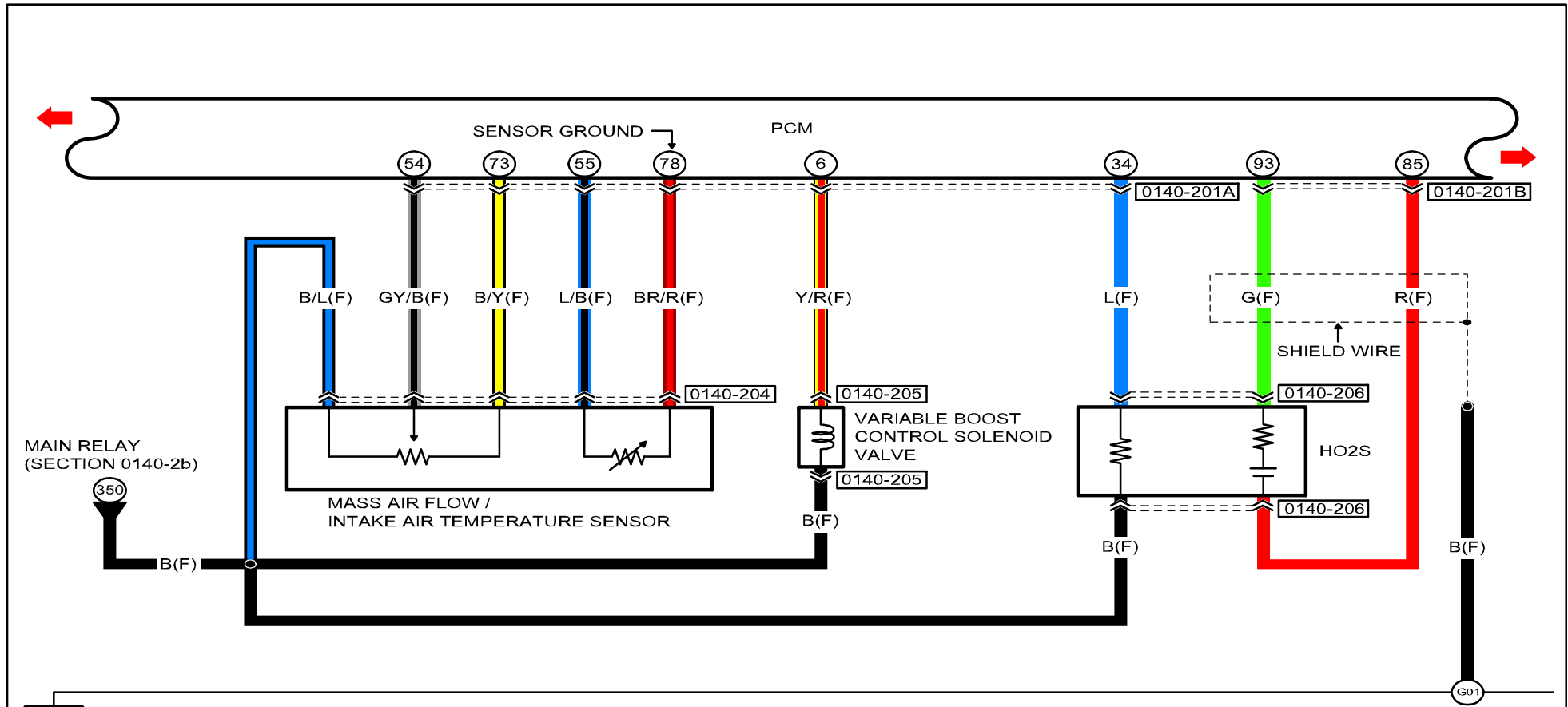

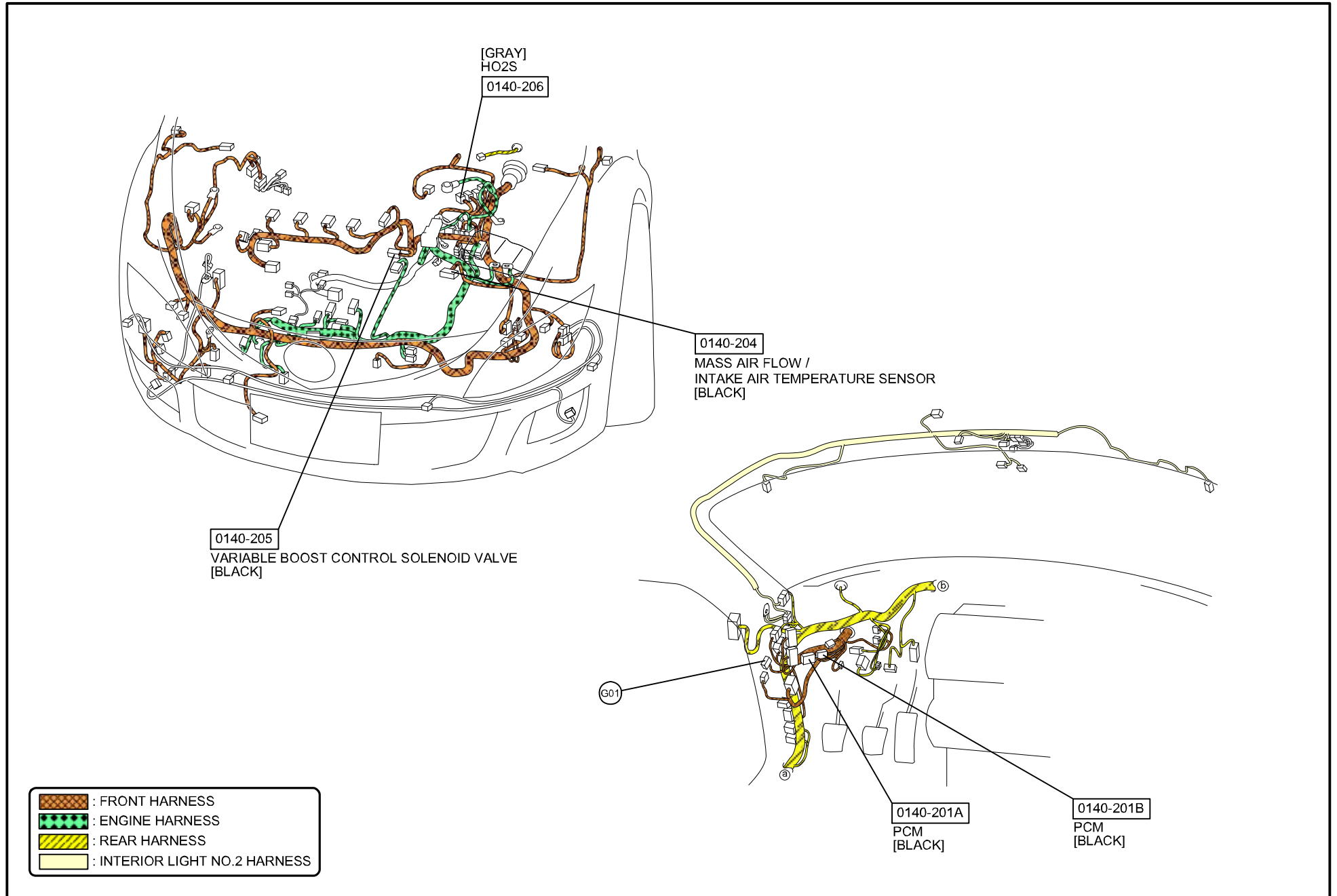

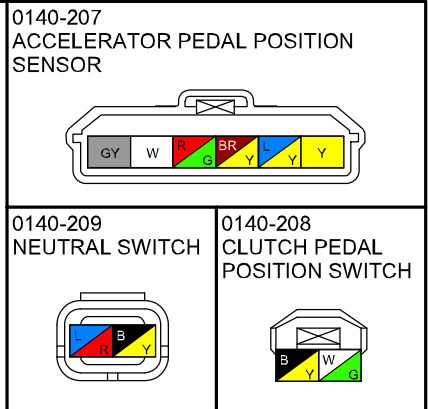
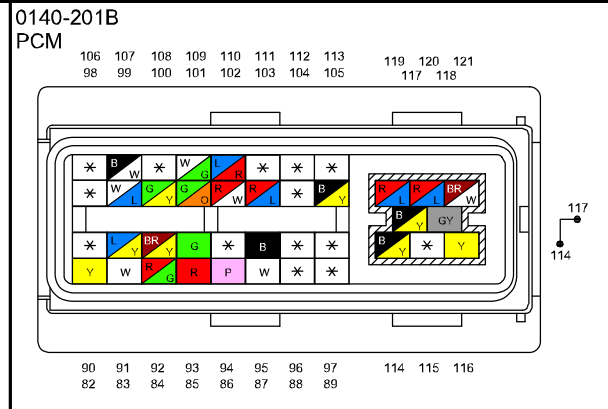
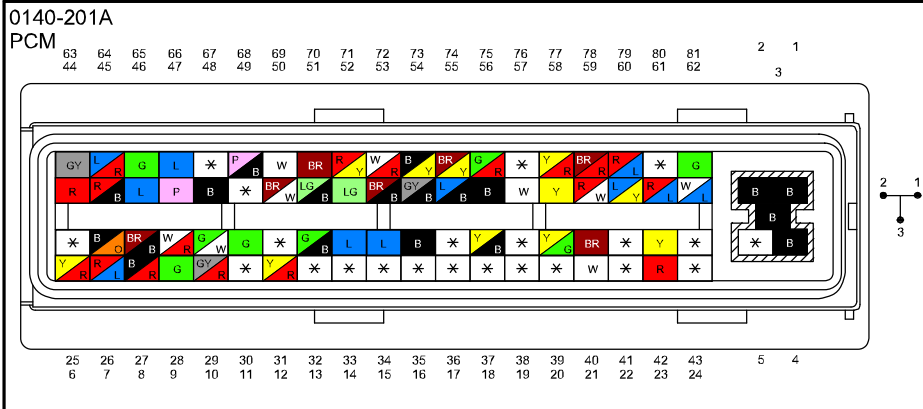
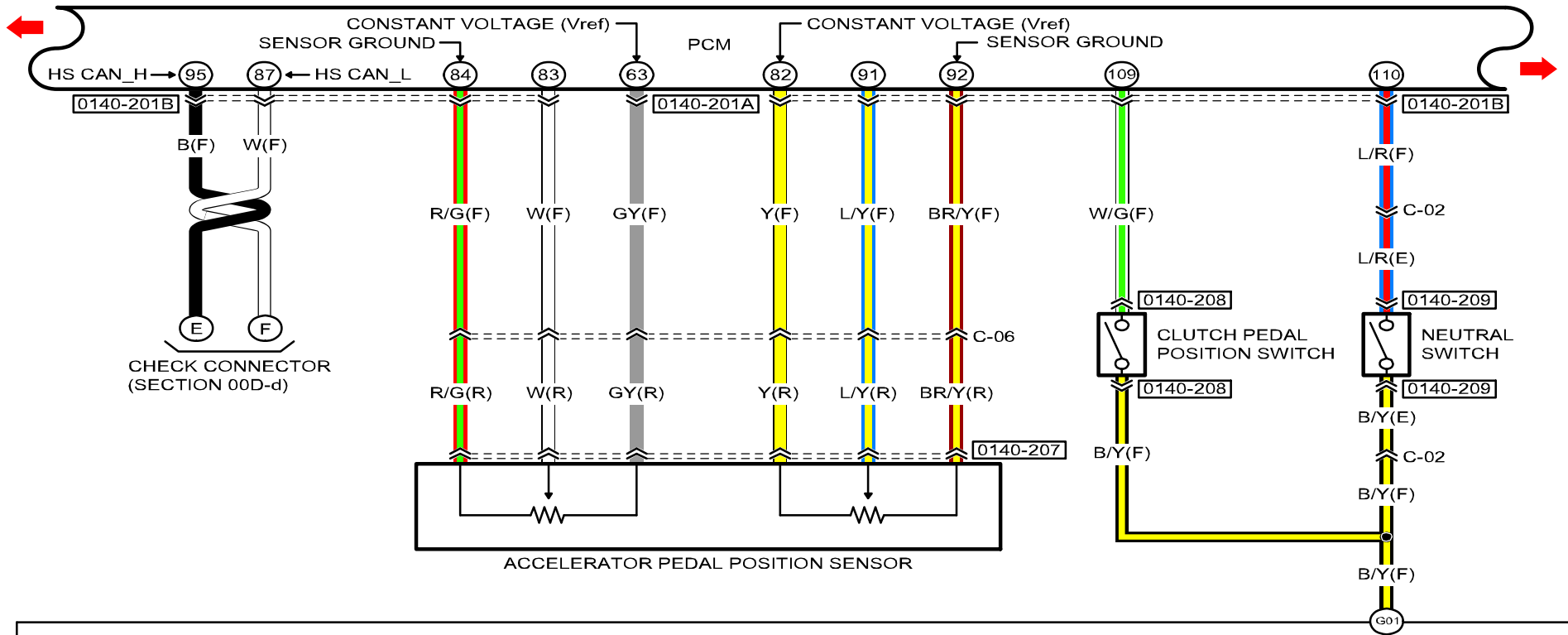

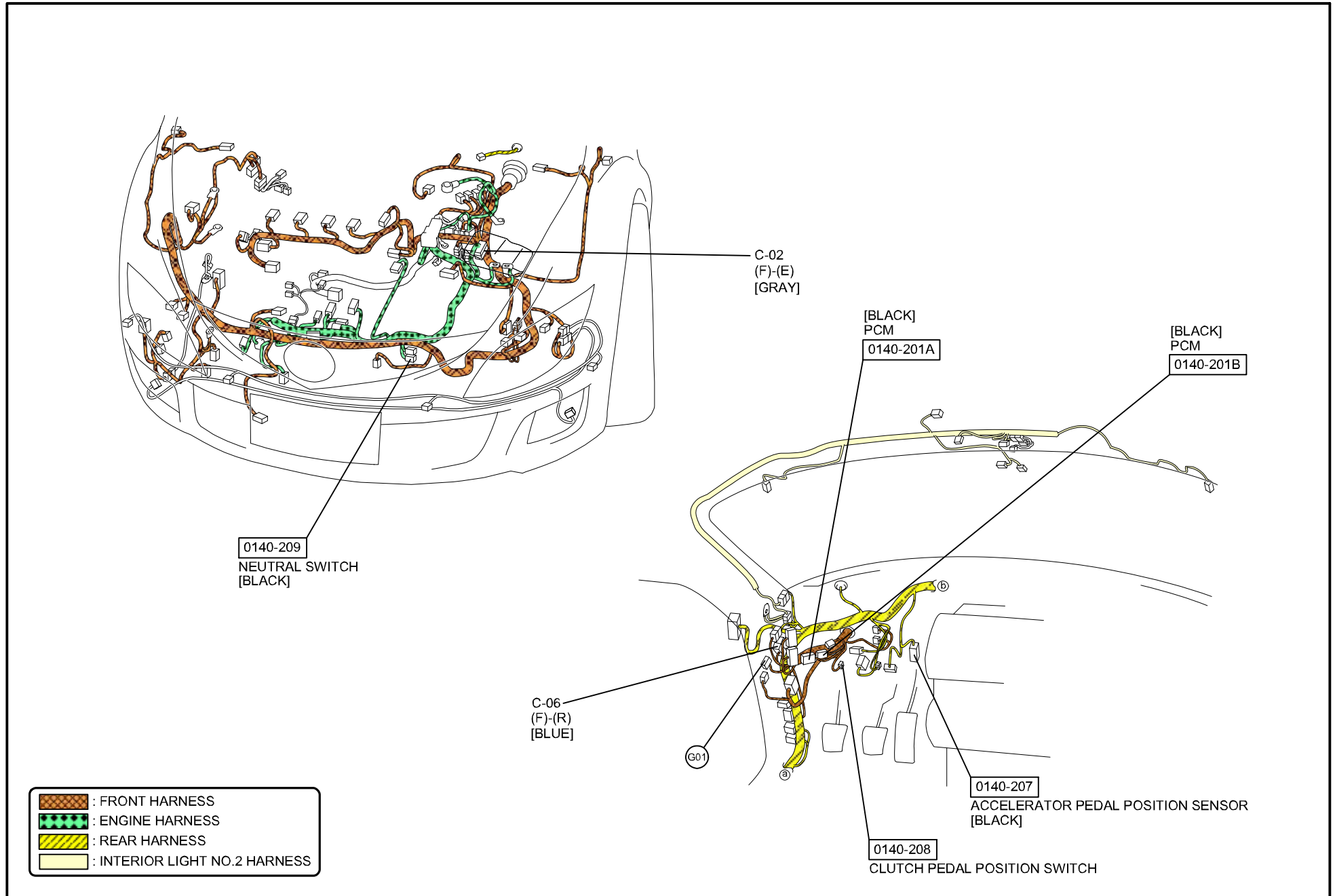

- [Brown checkered pattern] : FRONT HARNESS
- [Green with diamond pattern] : ENGINE HARNESS
- [Yellow with diagonal stripes] : REAR HARNESS
- [Solid yellow] : INTERIOR LIGHT NO.2 HARNESS

0140-209
NEUTRAL SWITCH
[BLACK]

C-02
(F)-(E)
[GRAY]

[BLACK]
PCM
0140-201A

[BLACK]
PCM
0140-201B

C-06
(F)-(R)
[BLUE]

G01

0140-207
ACCELERATOR PEDAL POSITION SENSOR
[BLACK]

0140-208
CLUTCH PEDAL POSITION SWITCH

C-02
FRONT HARNESS-ENGINE HARNESS

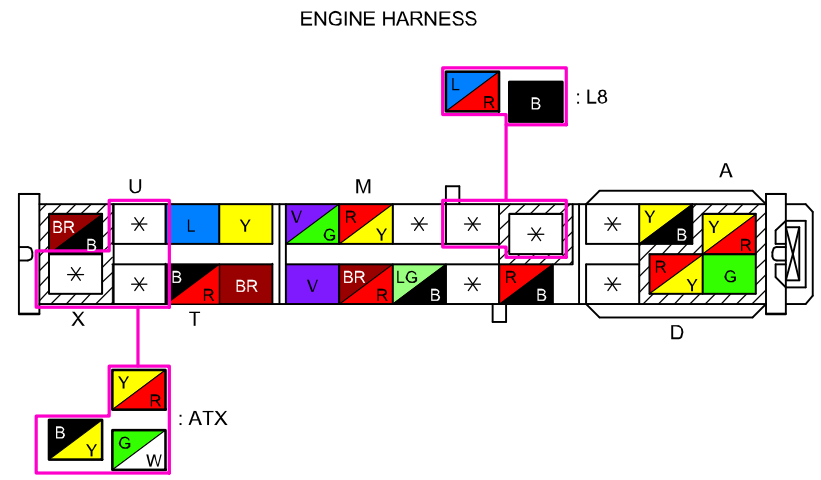
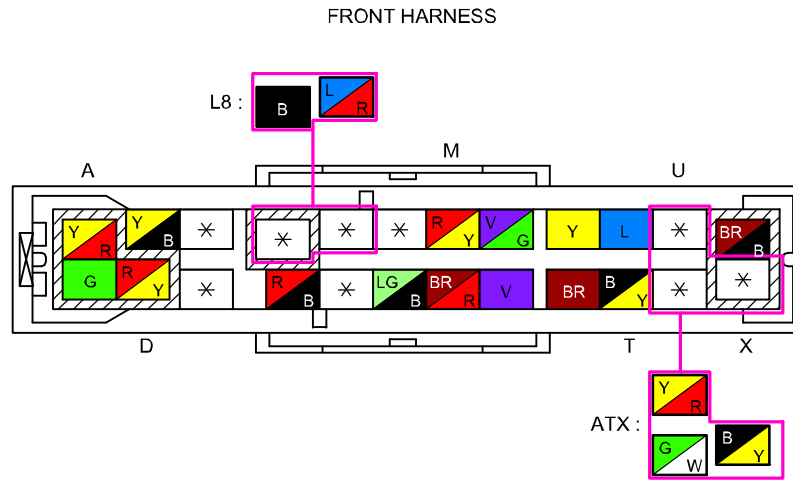

(EXCEPT MZR-CD (RF Turbo))

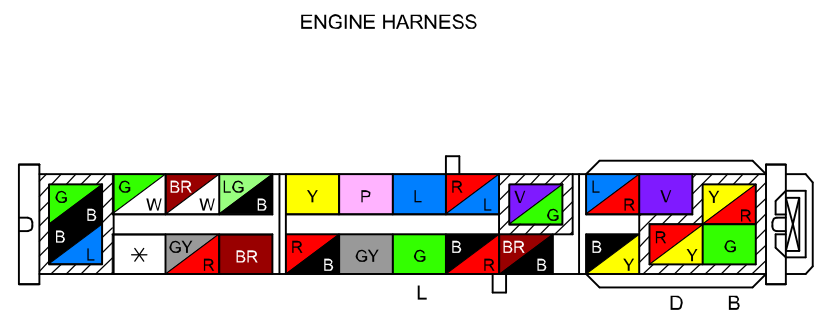
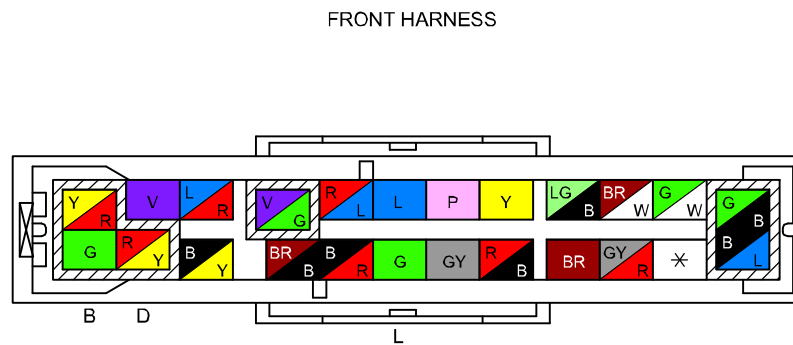

(MZR-CD (RF Turbo))

CONTROL SYSTEM (MZR-CD (RF Turbo))

0140-2e

C-06

FRONT HARNESS-REAR HARNESS

FRONT HARNESS

REAR HARNESS

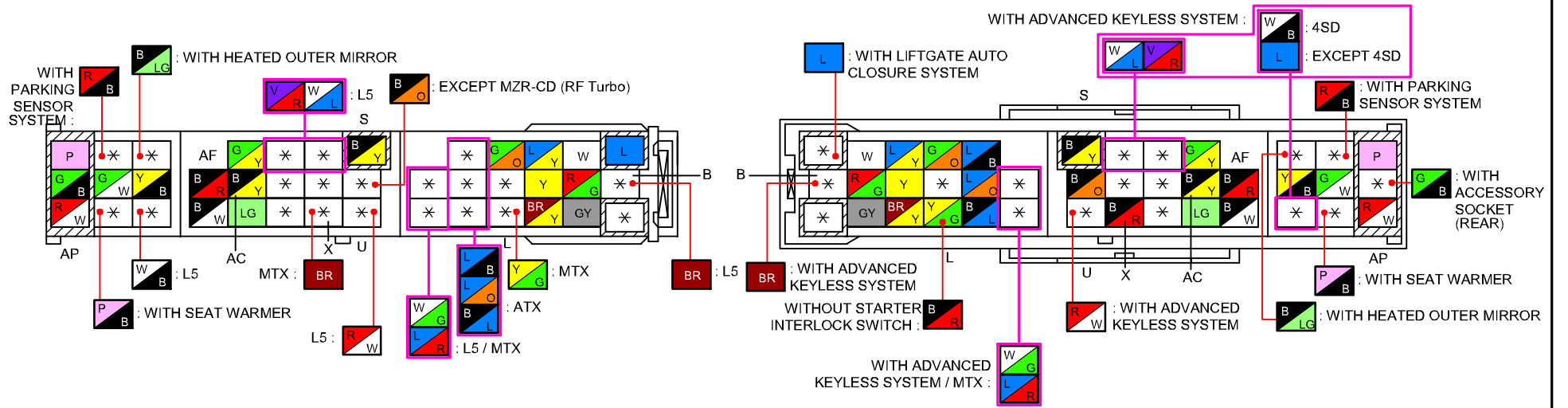

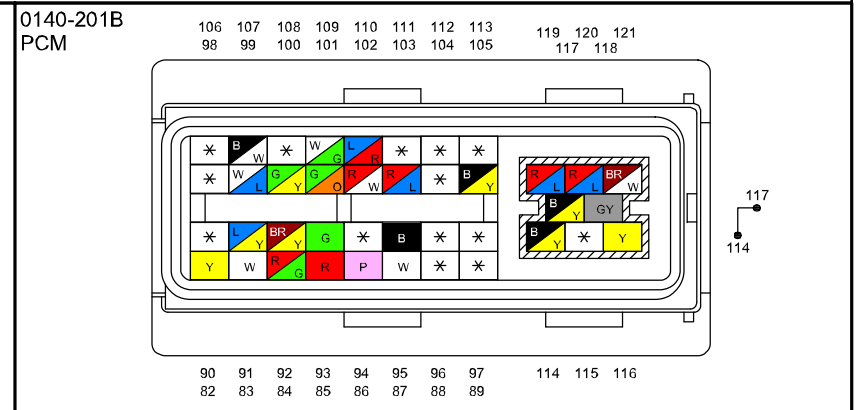
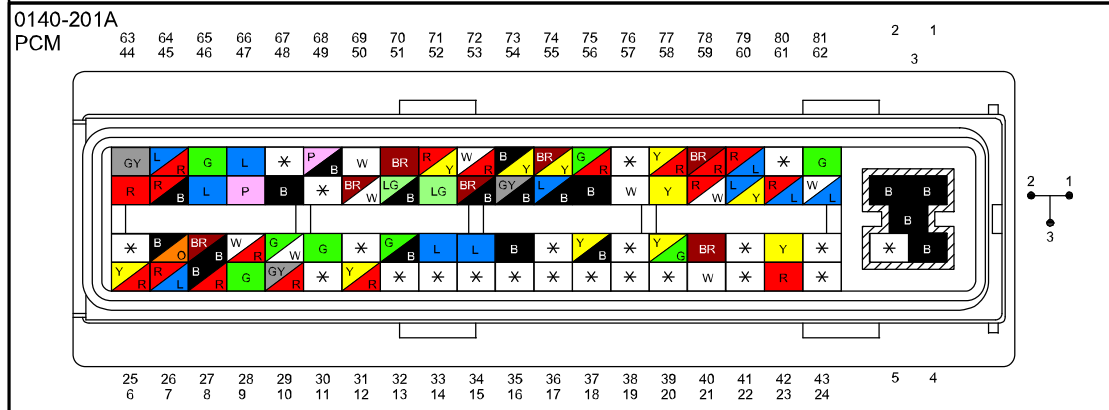
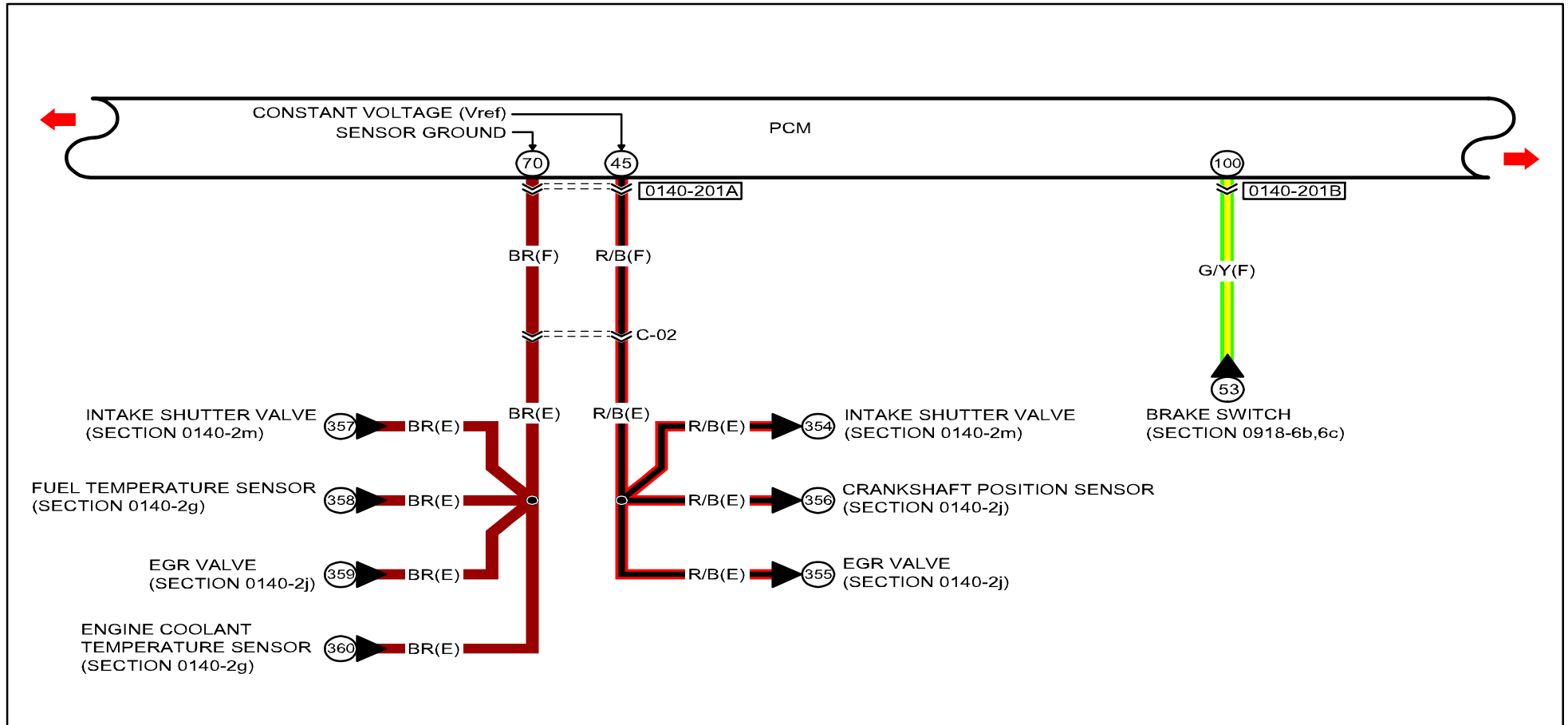

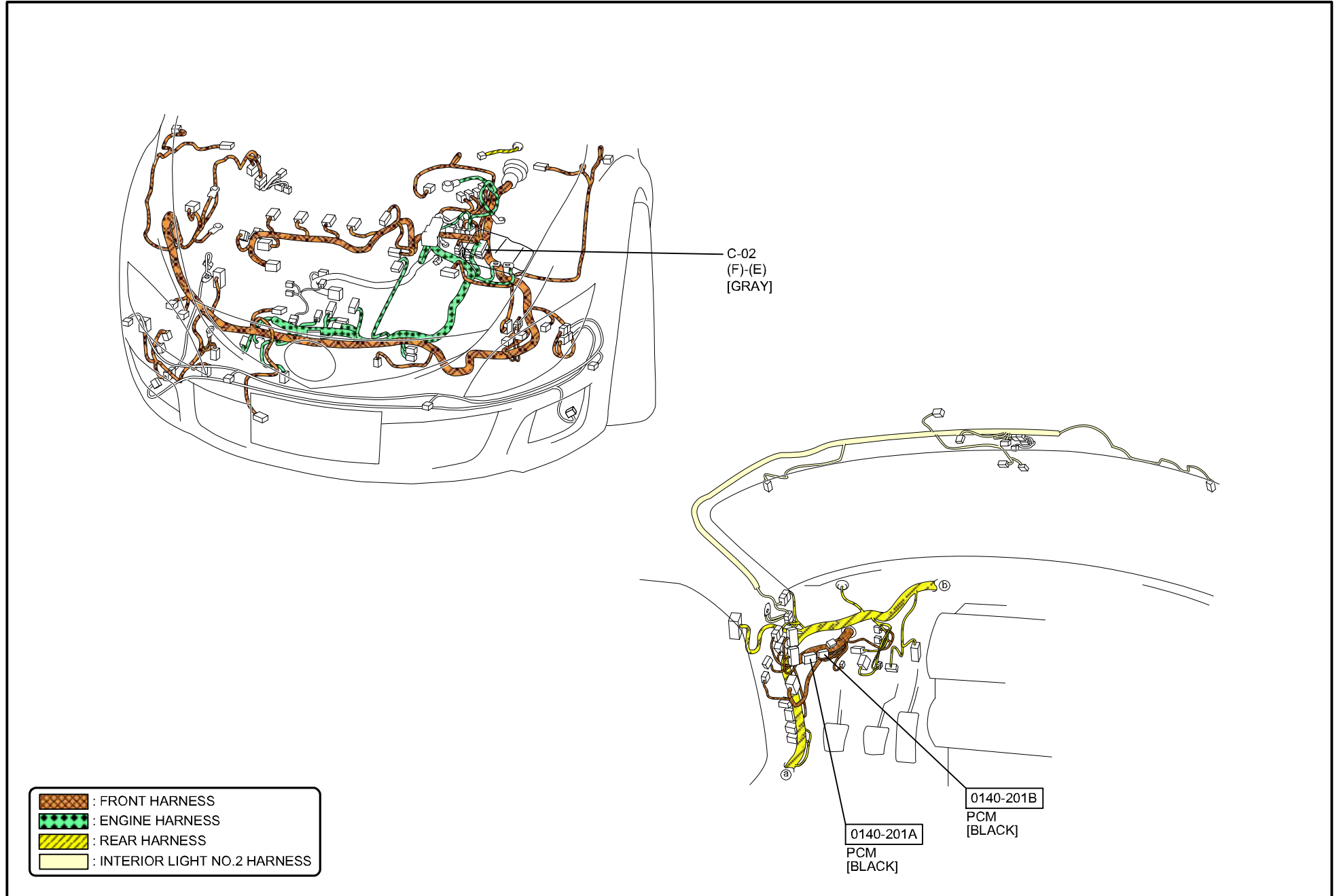

C-02

FRONT HARNESS-ENGINE HARNESS

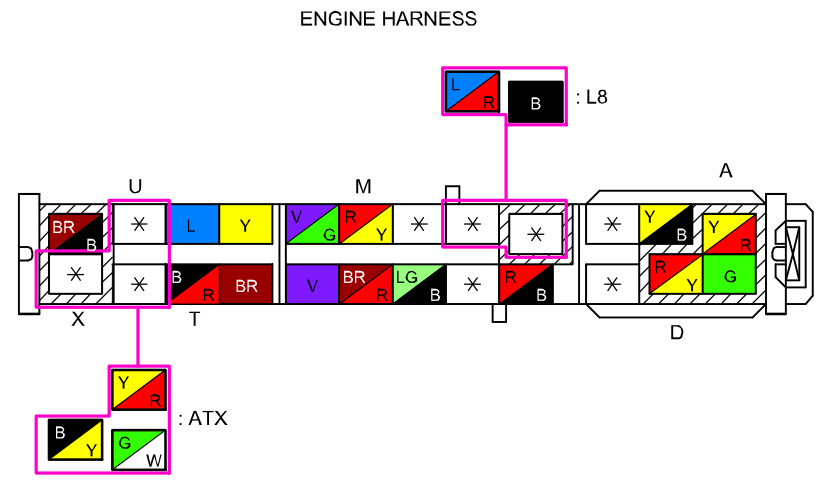
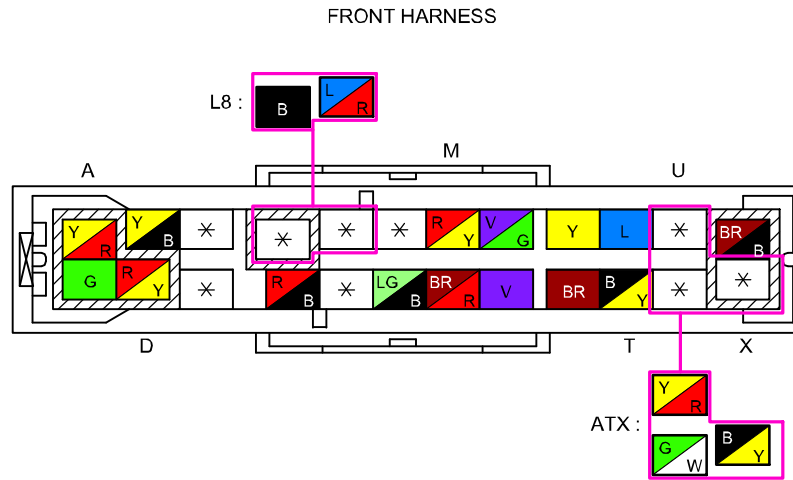

(EXCEPT MZR-CD (RF Turbo))

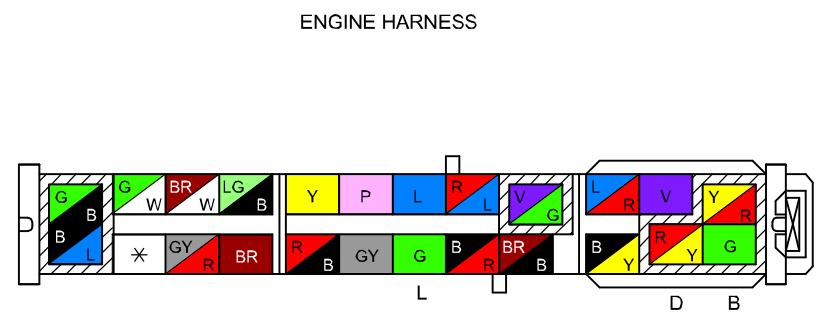
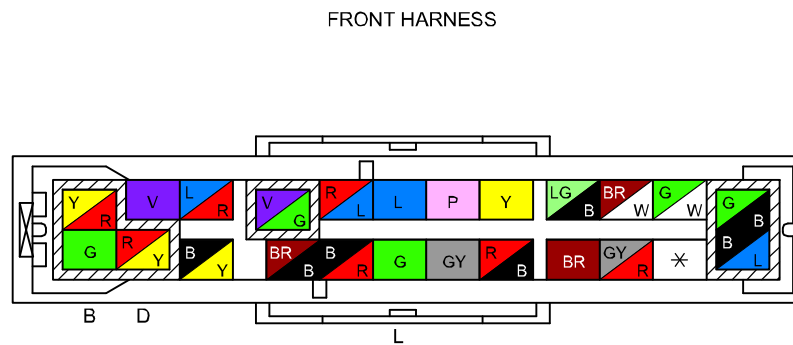

(MZR-CD (RF Turbo))

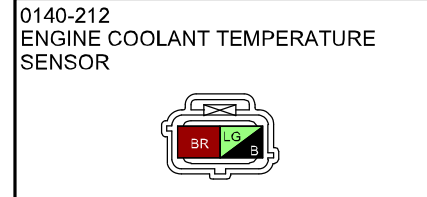
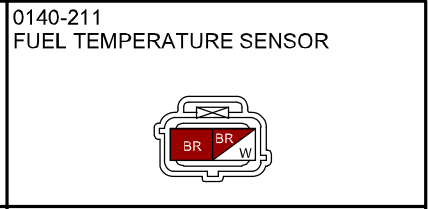
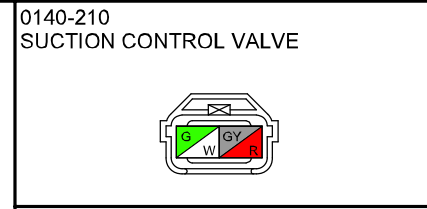
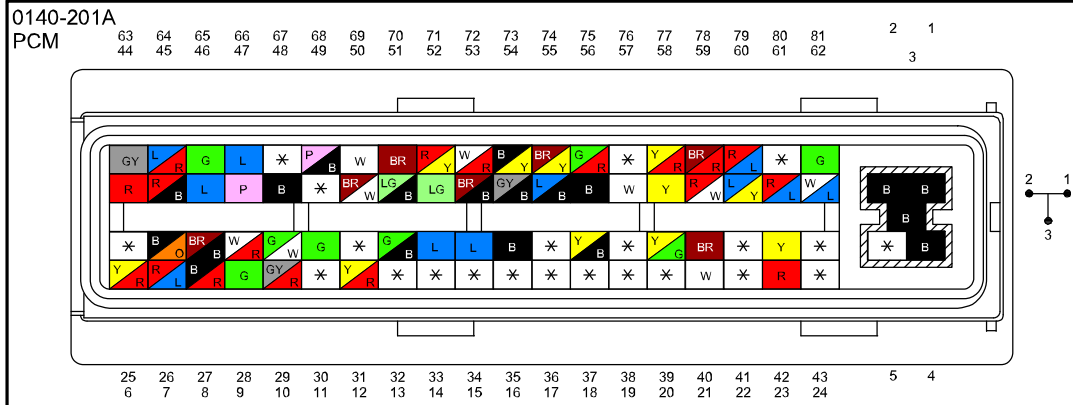
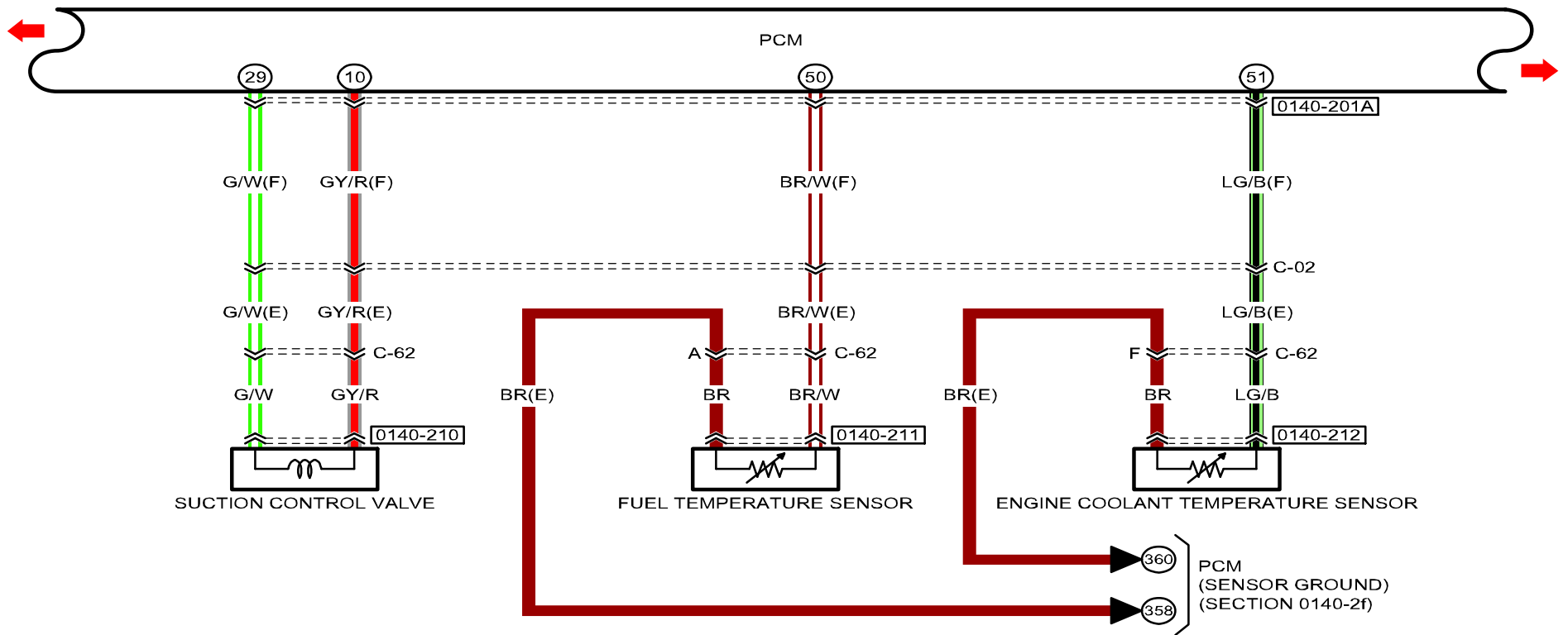

CONTROL SYSTEM (MZR-CD (RF Turbo))

0140-2g

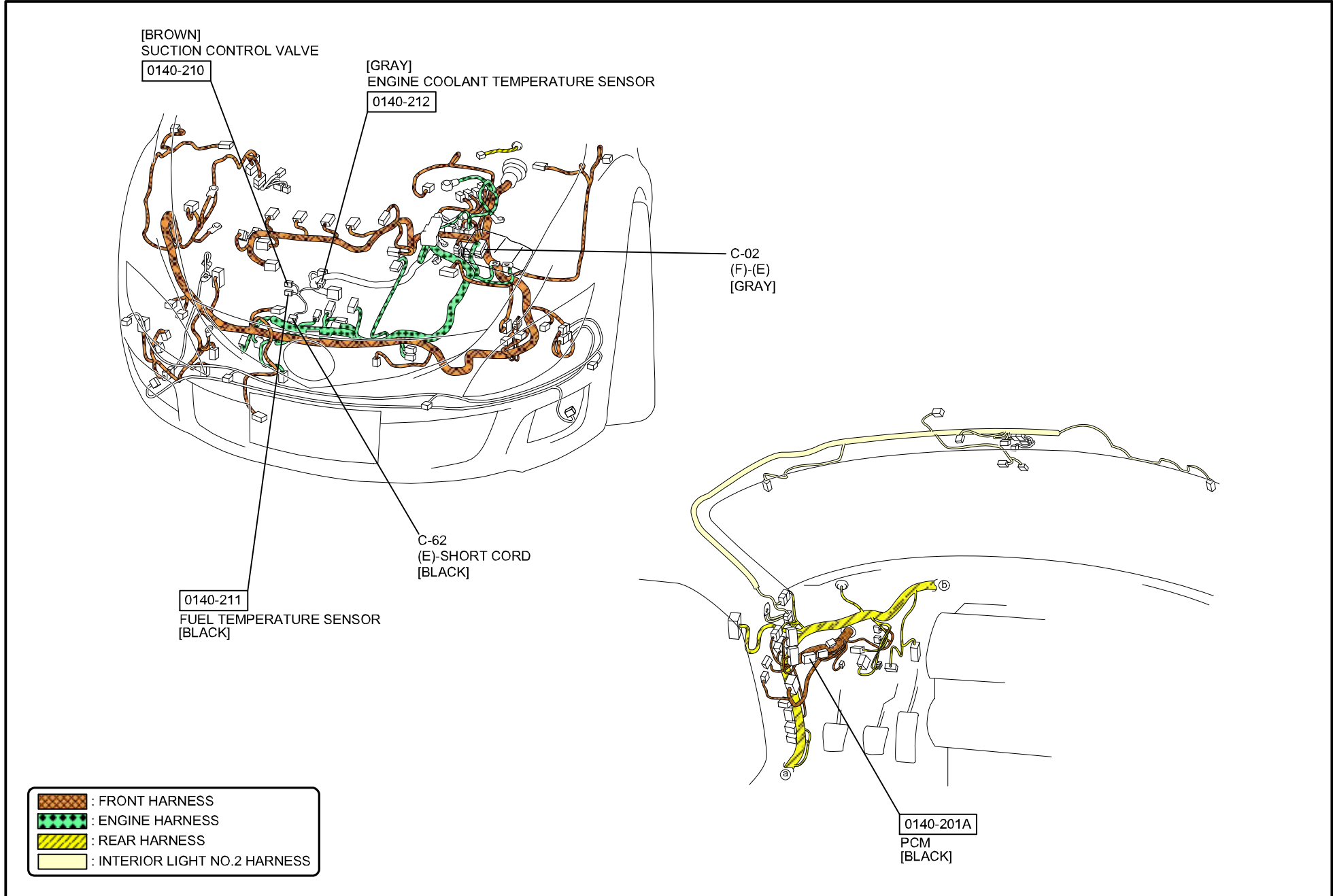

C-02
FRONT HARNESS-ENGINE HARNESS

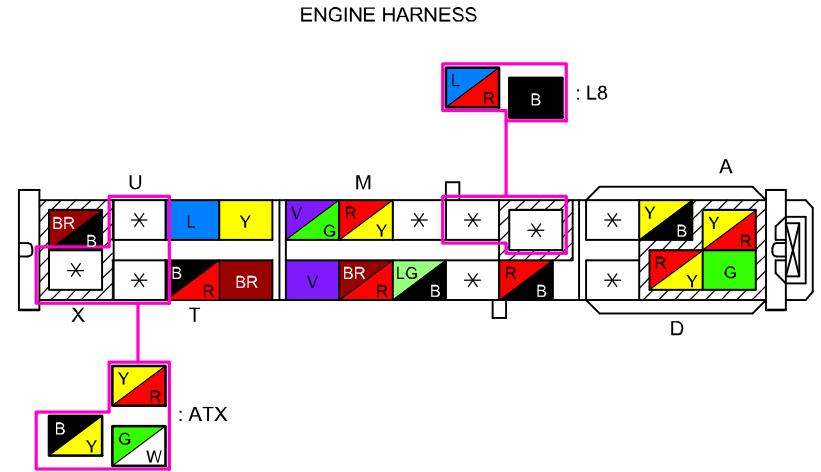
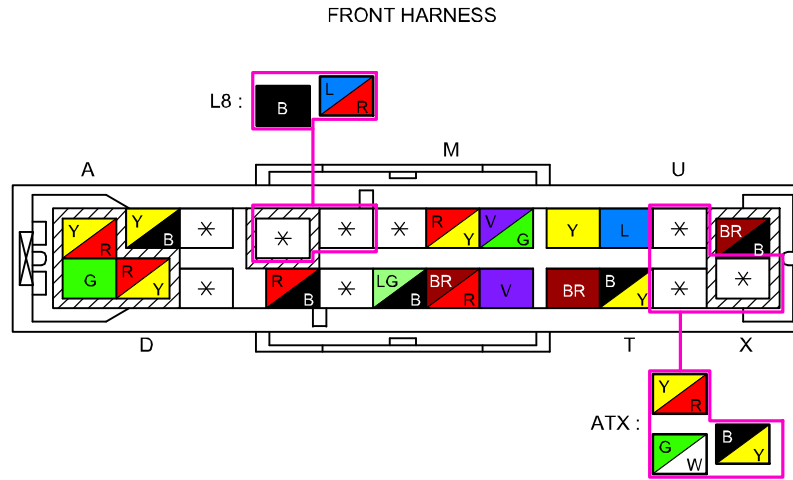

(EXCEPT MZR-CD (RF Turbo))

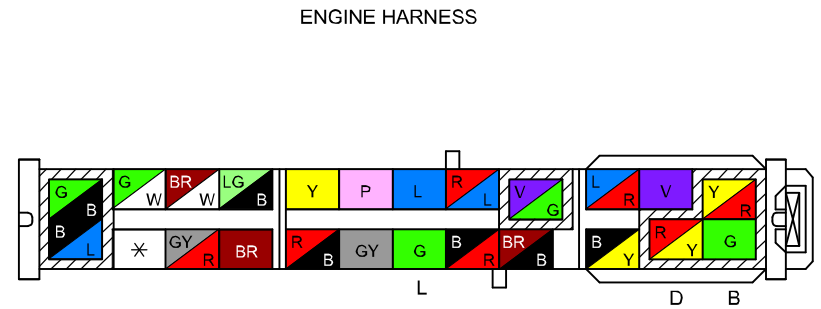
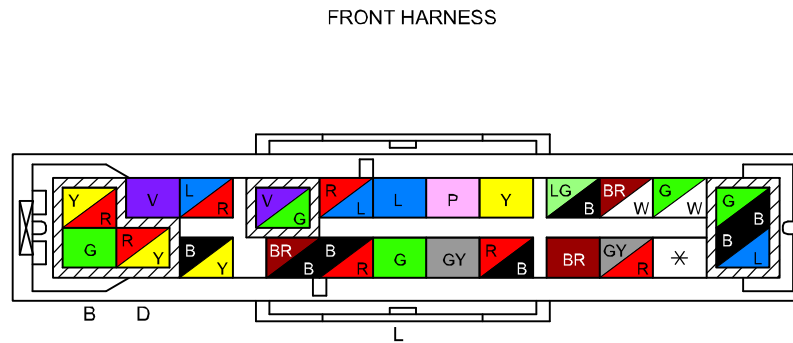

(MZR-CD (RF Turbo))

C-62
ENGINE HARNESS-SHORT CORD

ENGINE HARNESS

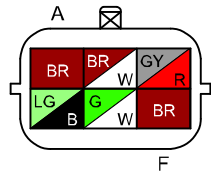

SHORT CORD

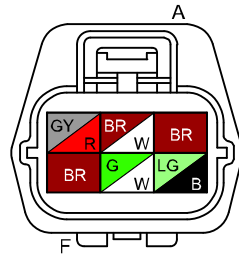

(MZR-CD (RF Turbo))

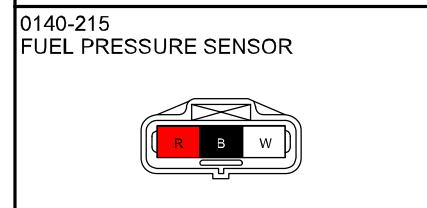
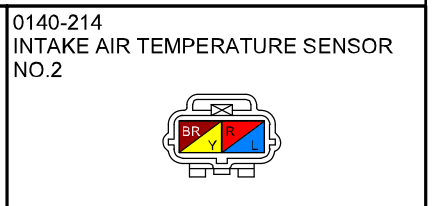
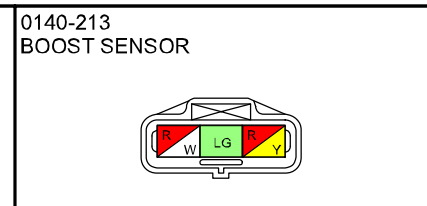
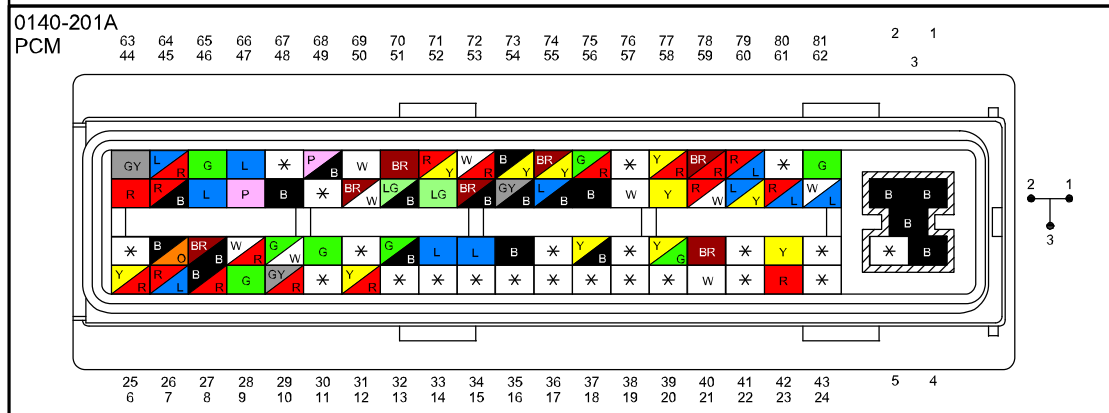
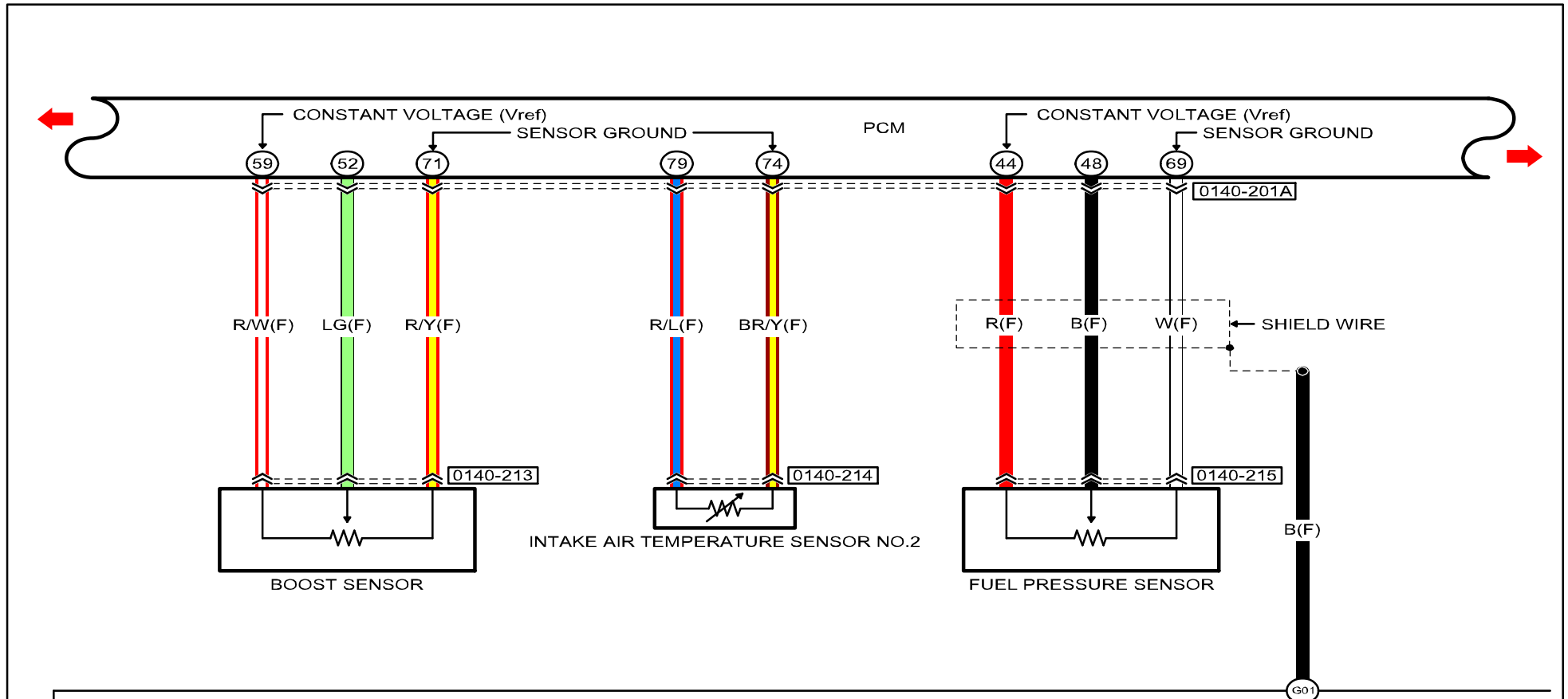

CONTROL SYSTEM (MZR-CD (RF Turbo))

0140-2h

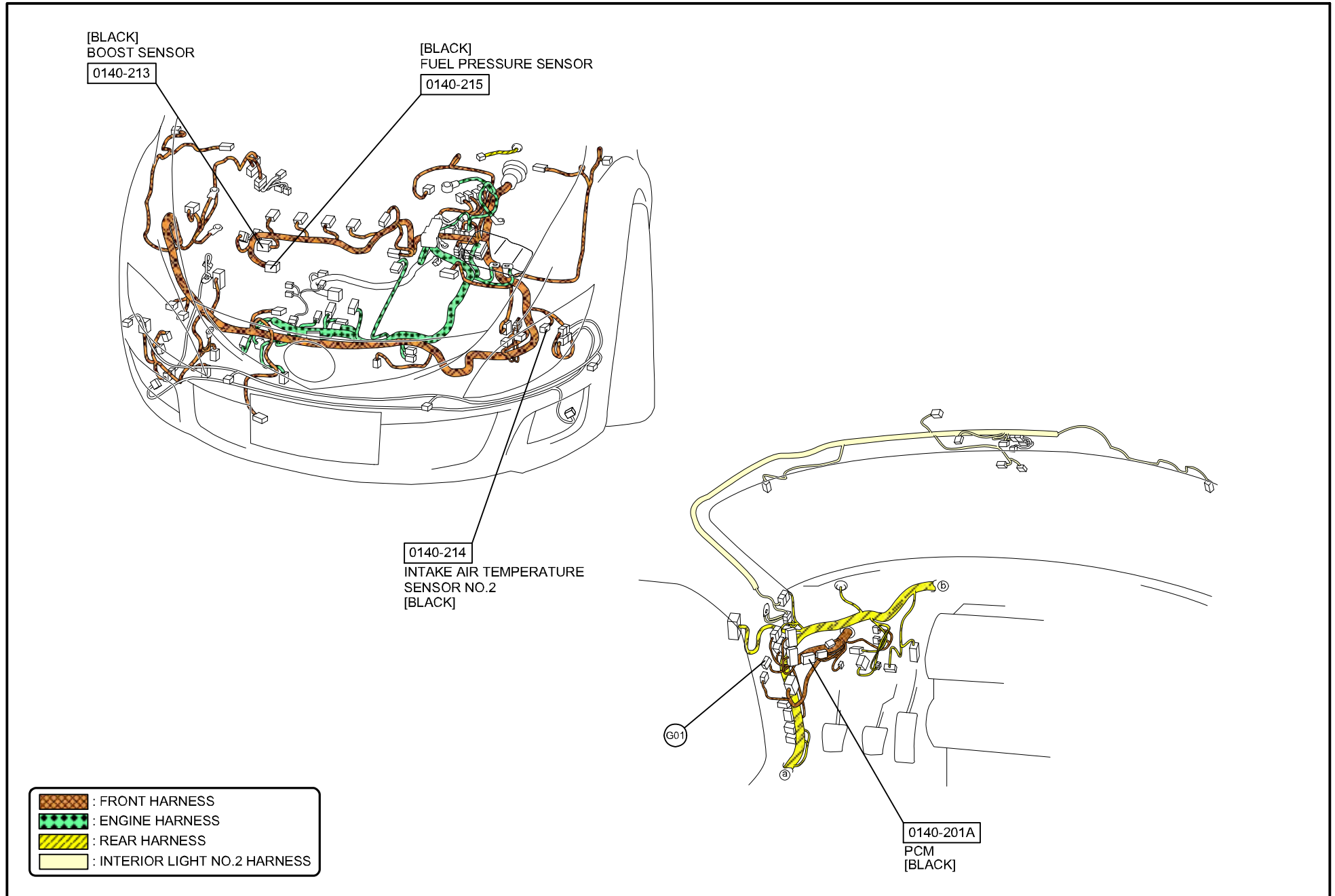

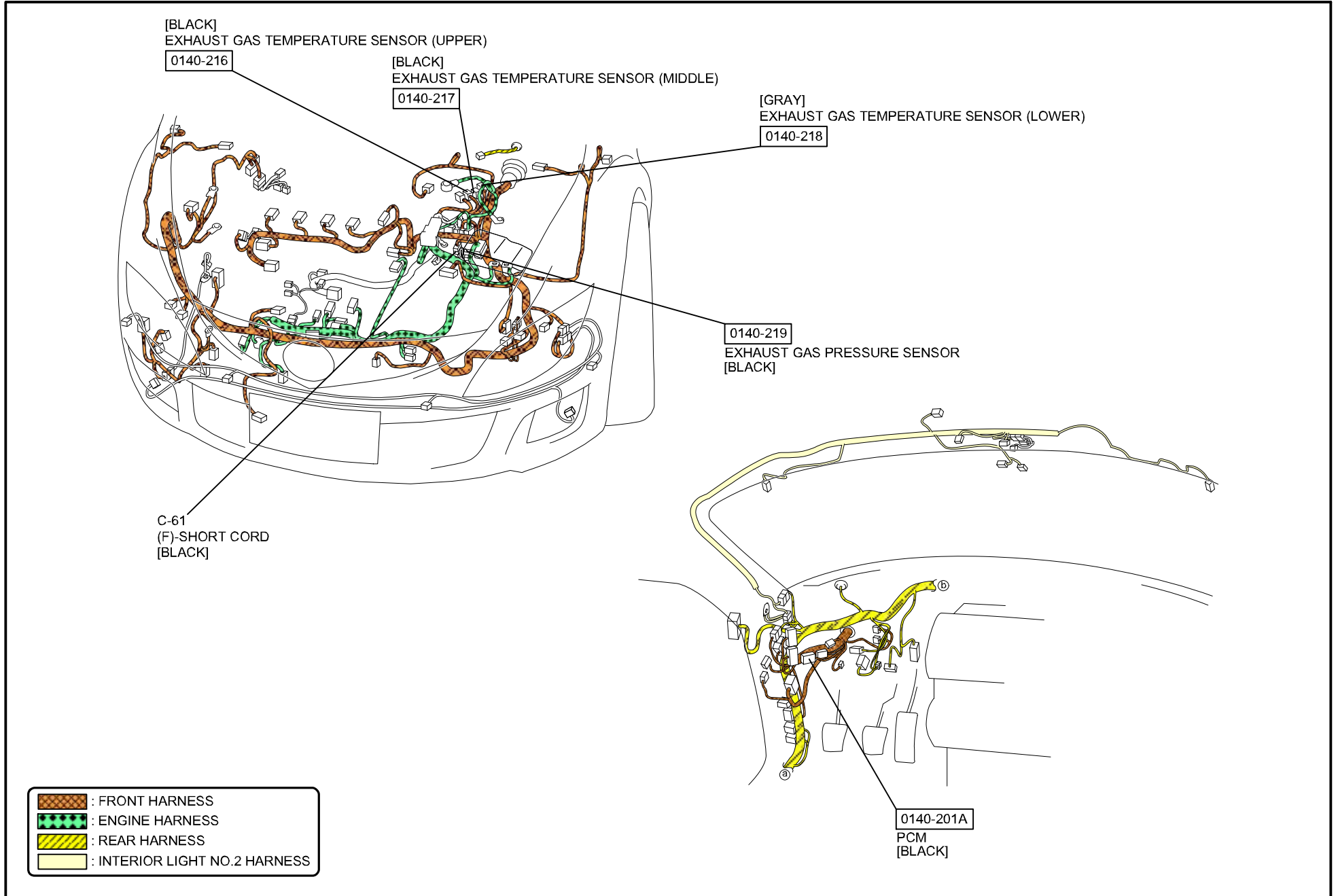

C-61
FRONT HARNESS-SHORT CORD

FRONT HARNESS

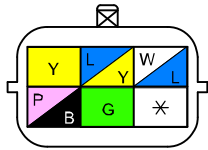

SHORT CORD

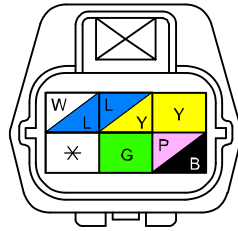

(MZR-CD (RF Turbo))

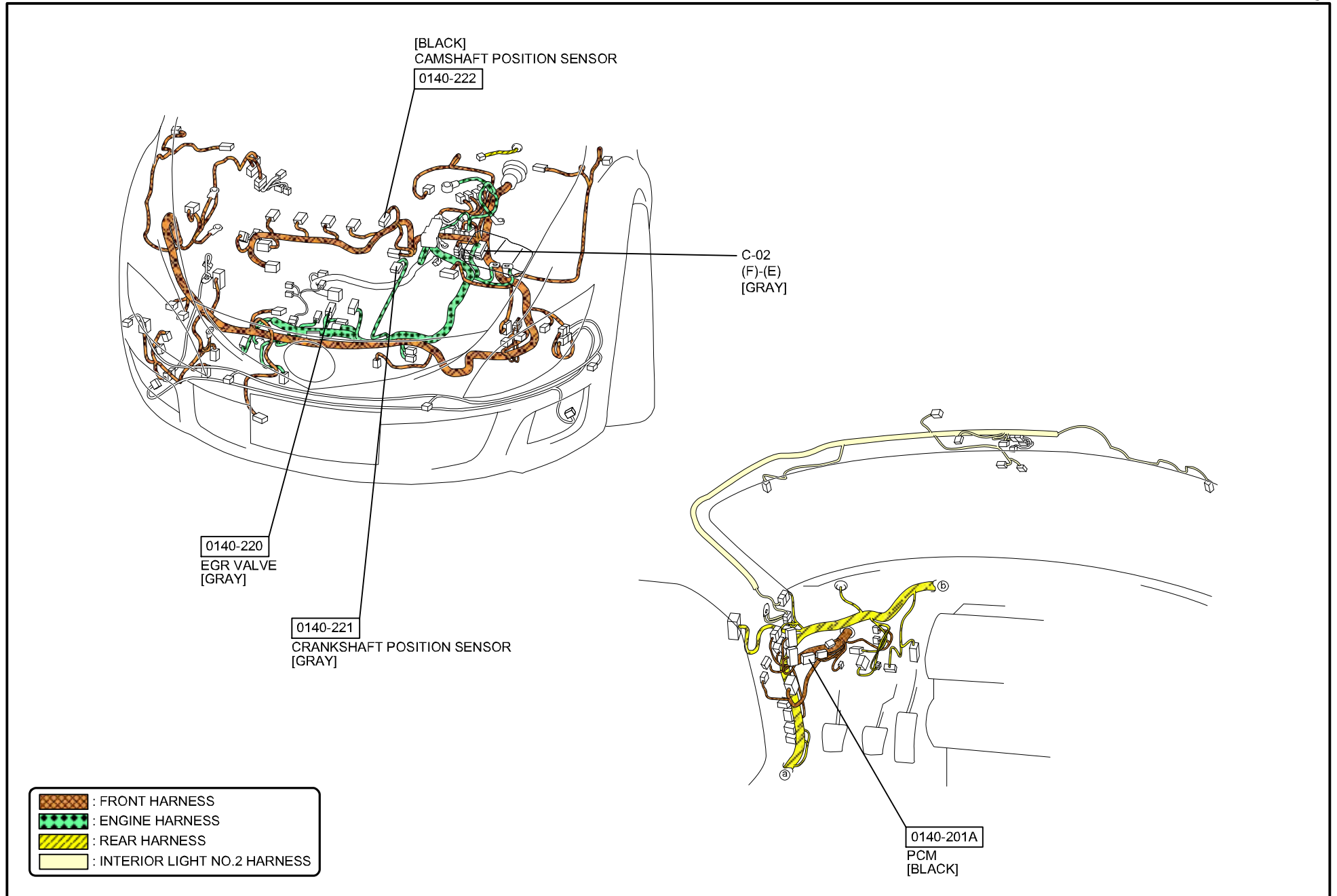

C-02
FRONT HARNESS-ENGINE HARNESS

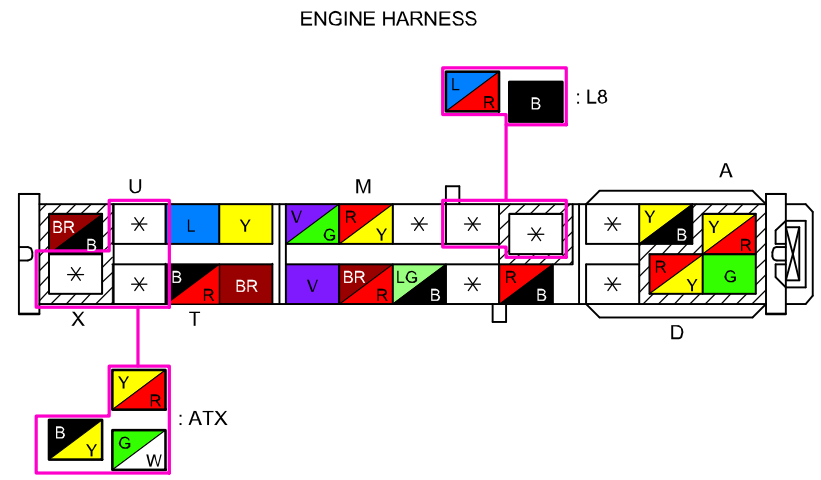
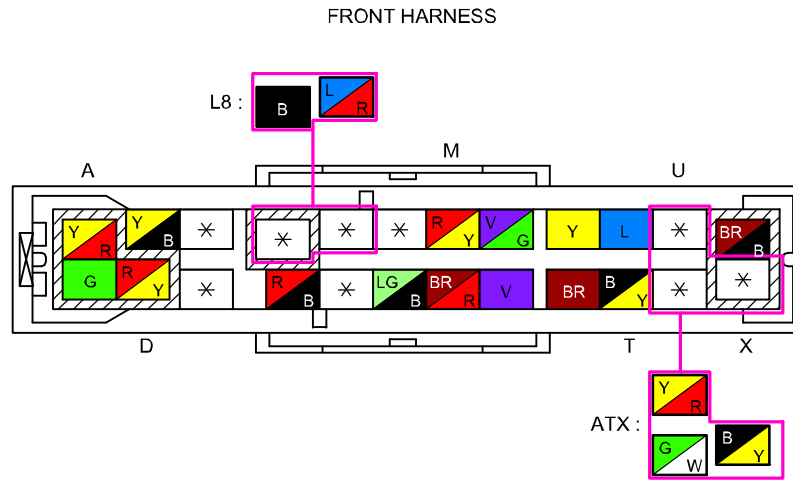

(EXCEPT MZR-CD (RF Turbo))

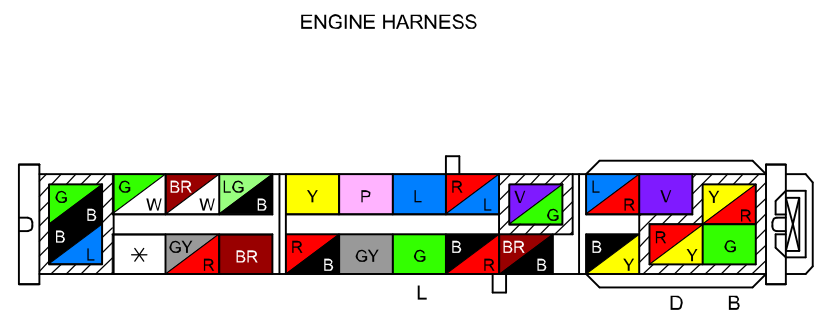
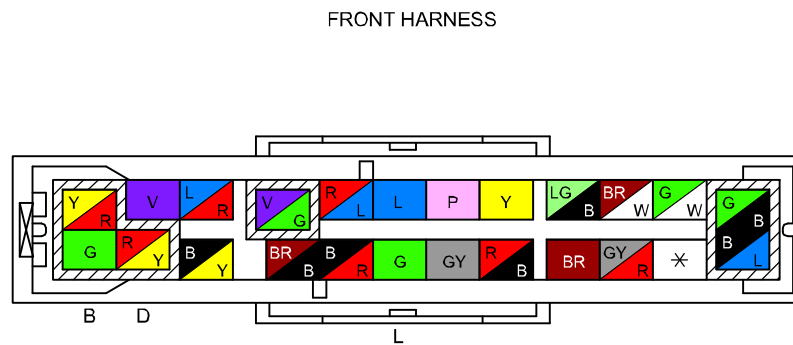

(MZR-CD (RF Turbo))

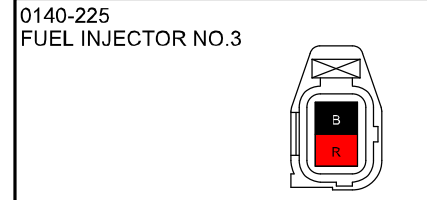
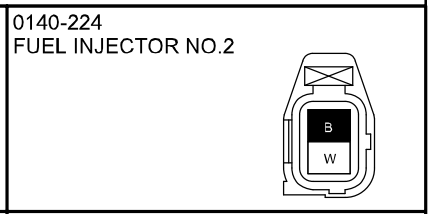
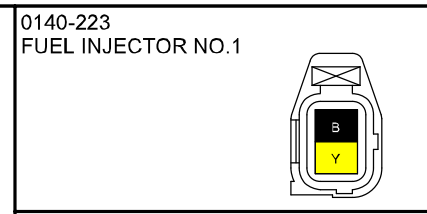
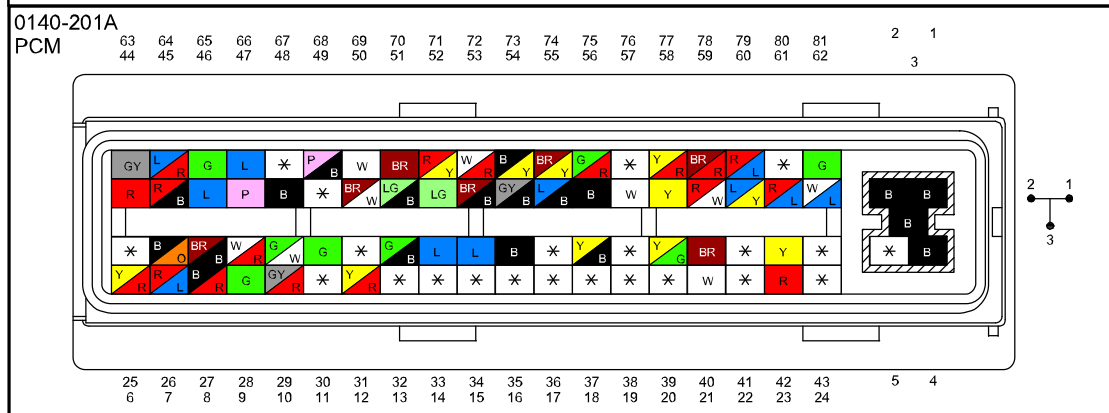
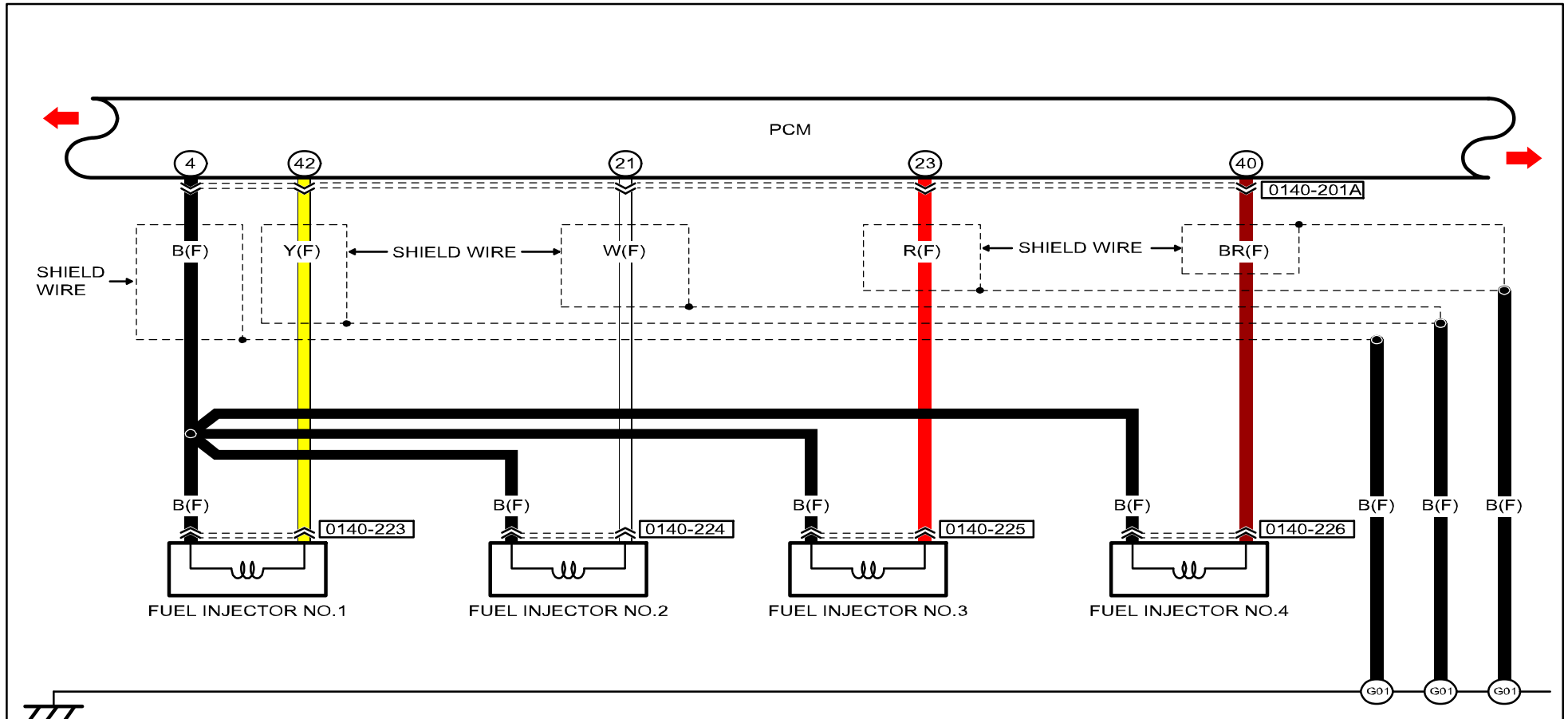

CONTROL SYSTEM (MZR-CD (RF Turbo))

0140-2k





[GRAY]
FUEL INJECTOR NO.1
0140-223

[GRAY]
FUEL INJECTOR NO.2
0140-224

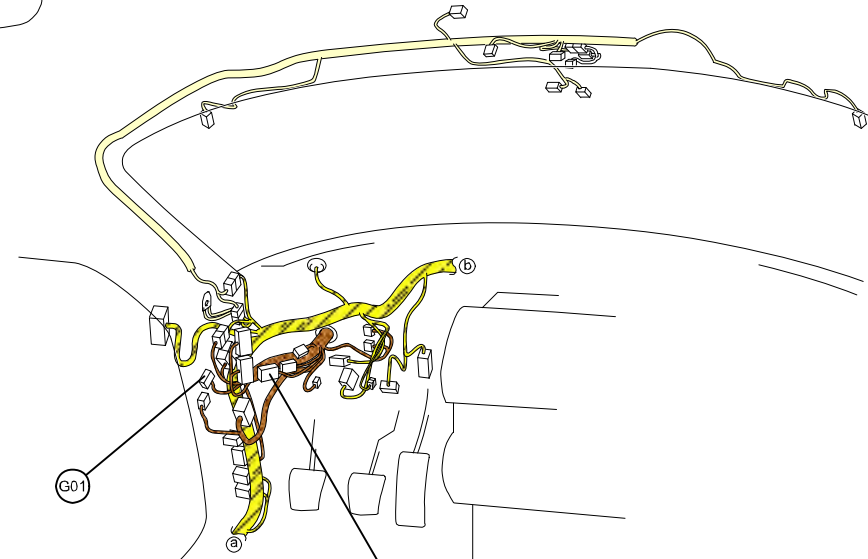
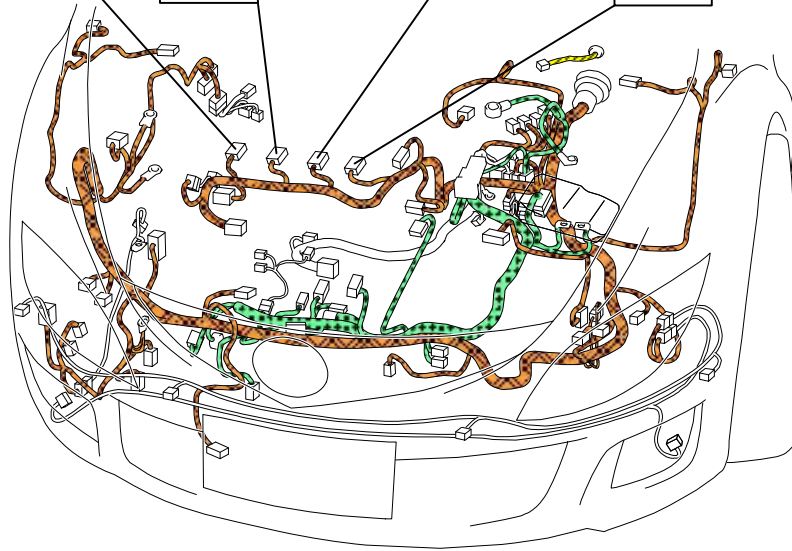
[GRAY]
FUEL INJECTOR NO.3
0140-225

[GRAY]
FUEL INJECTOR NO.4
0140-226



-  : FRONT HARNESS
-  : ENGINE HARNESS
-  : REAR HARNESS
-  : INTERIOR LIGHT NO.2 HARNESS

0140-201A
PCM
[BLACK]

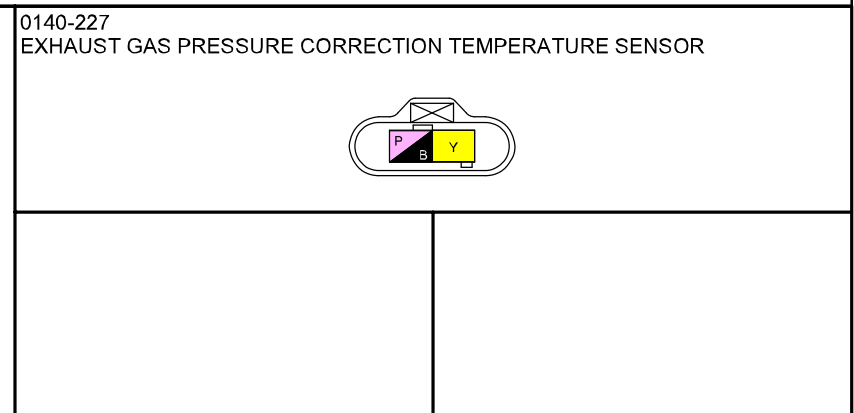
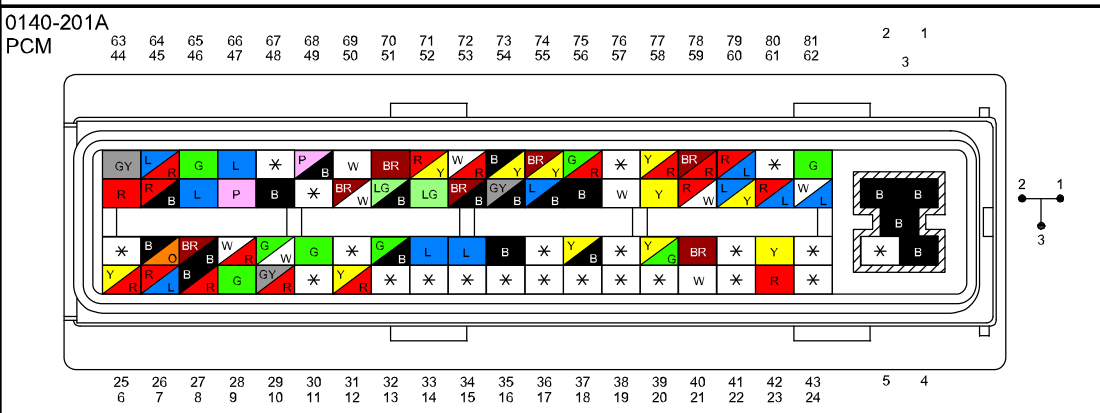
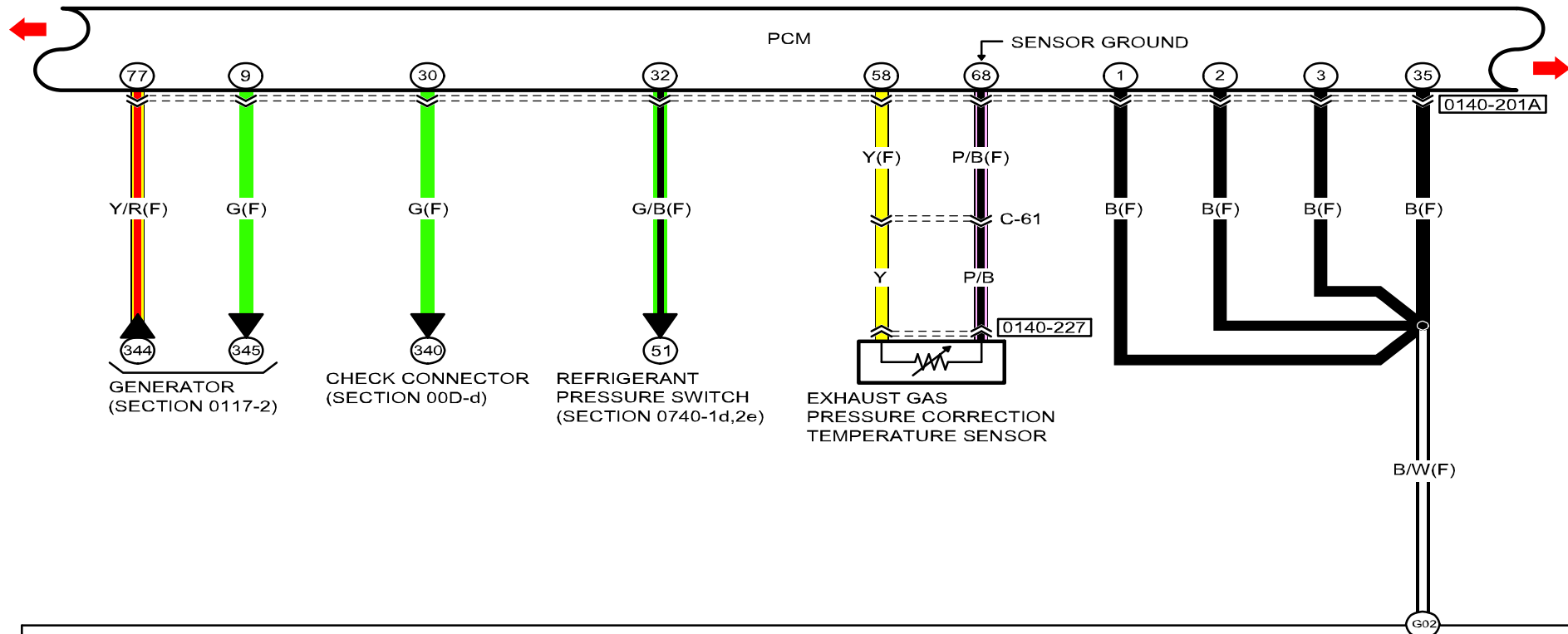

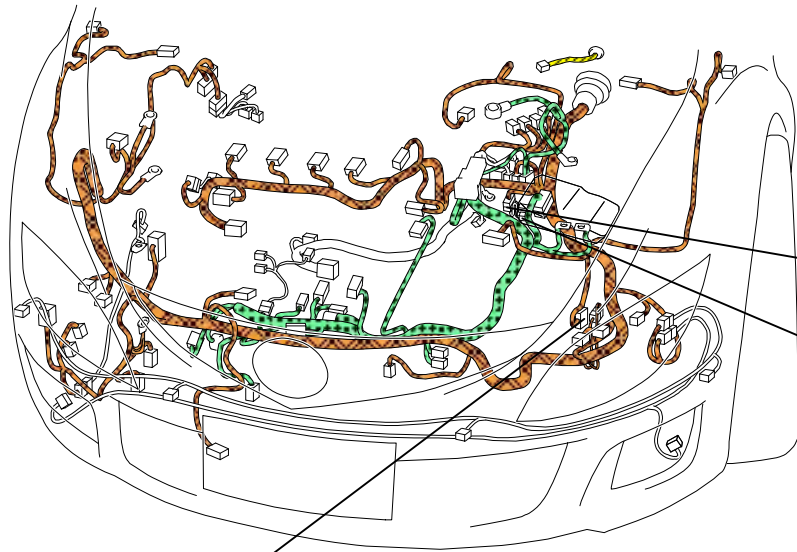



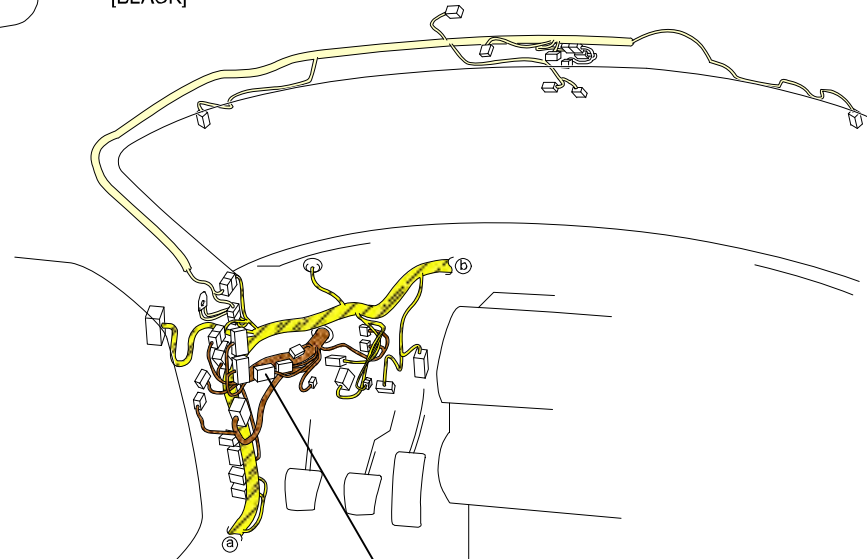

G02

C-61
(F)-SHORT CORD
[BLACK]

0140-227
EXHAUST GAS PRESSURE CORRECTION TEMPERATURE SENSOR
[BLACK]



0140-201A
PCM
[BLACK]

-  : FRONT HARNESS
-  : ENGINE HARNESS
-  : REAR HARNESS
-  : INTERIOR LIGHT NO.2 HARNESS

C-61
FRONT HARNESS-SHORT CORD

FRONT HARNESS

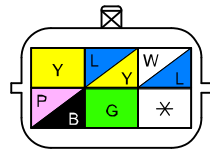

SHORT CORD

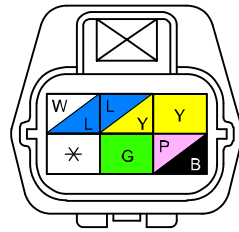

(MZR-CD (RF Turbo))

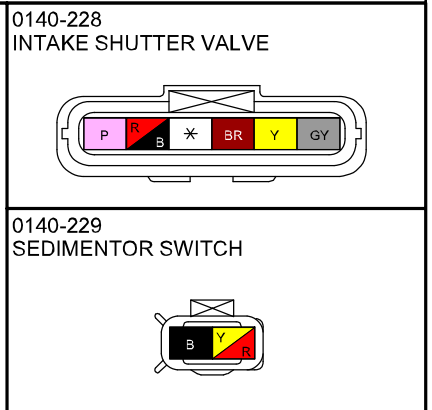
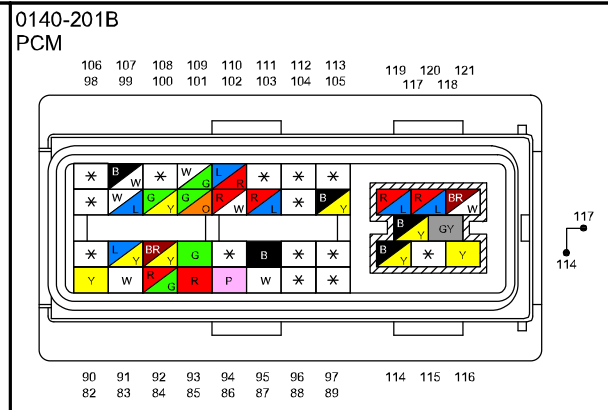
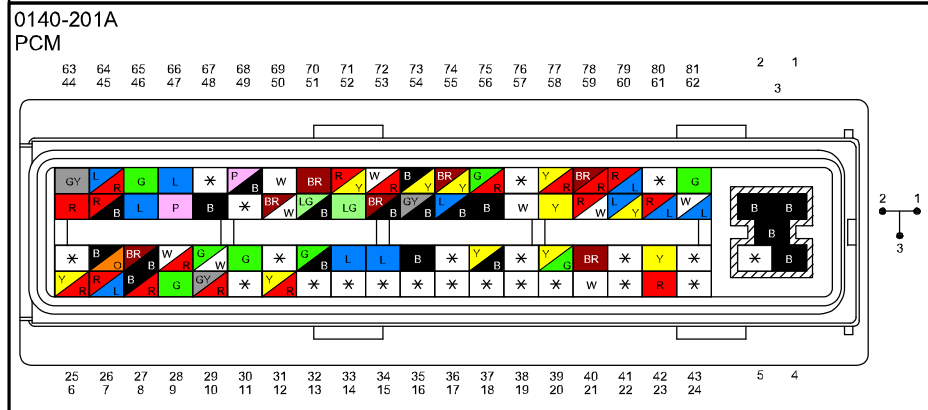
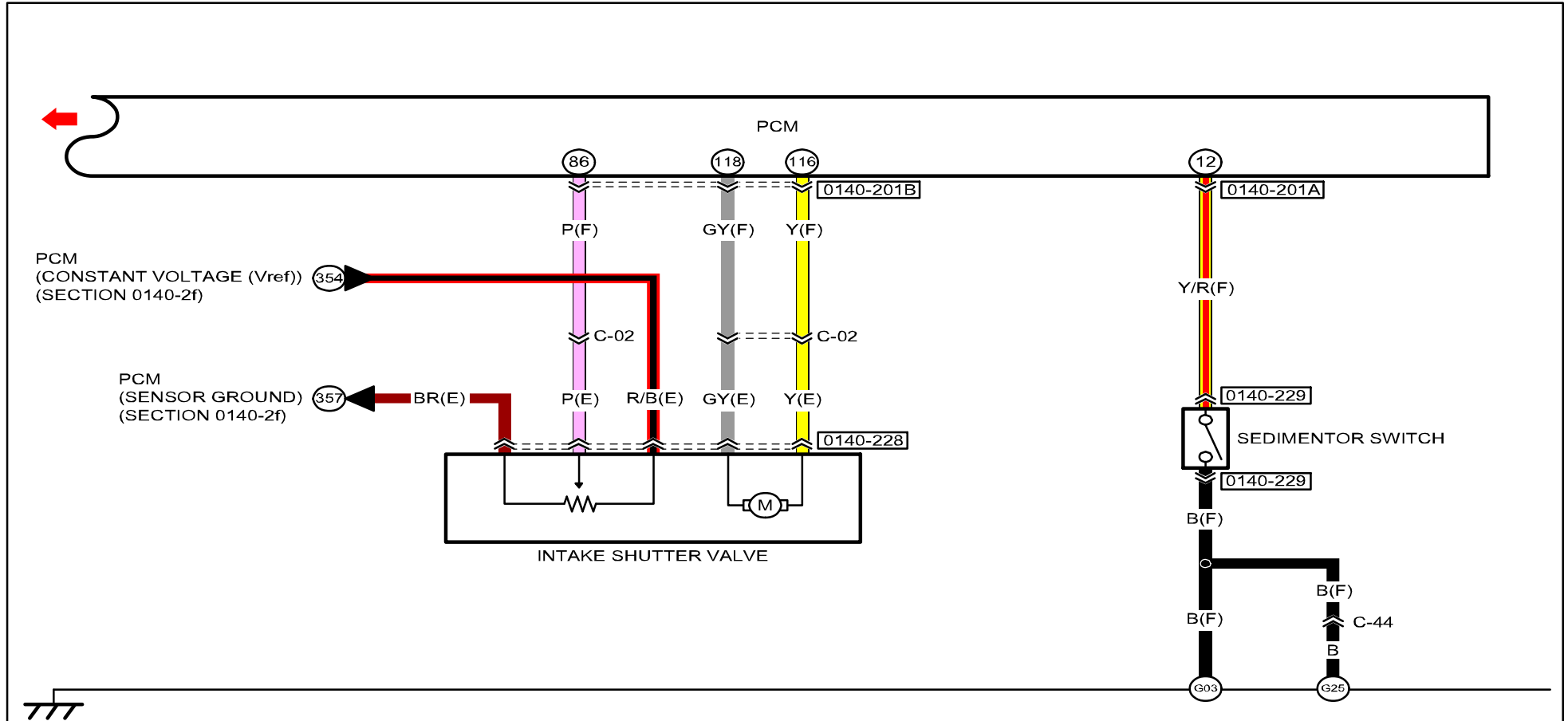

CONTROL SYSTEM (MZR-CD (RF Turbo))

0140-2m

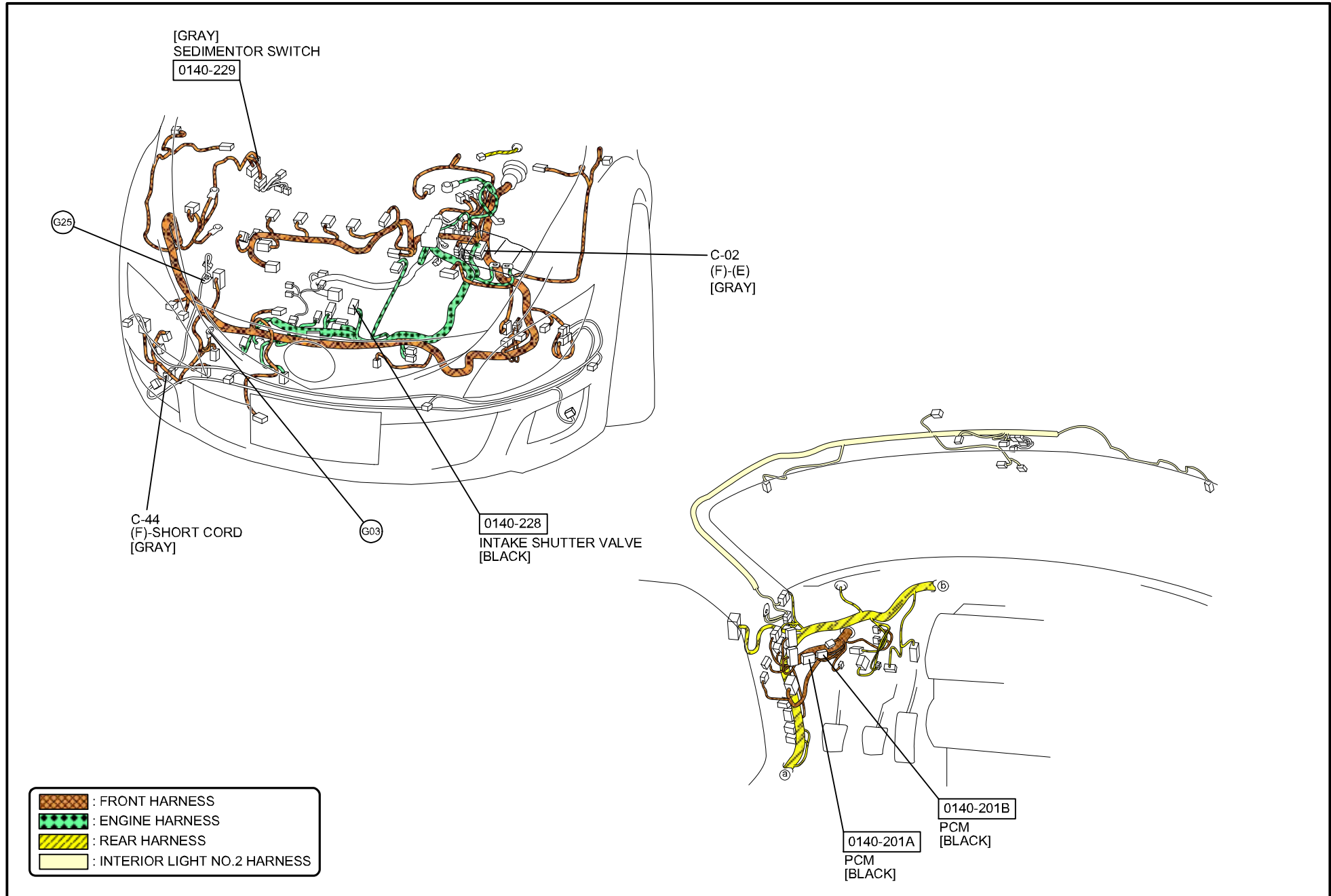

C-44
FRONT HARNESS-SHORT CORD

FRONT HARNESS

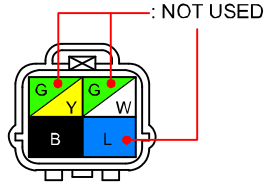

(WITH HEADLIGHT MANUAL LEVELING SYSTEM)

SHORT CORD

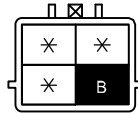

FRONT HARNESS

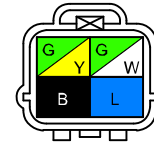

(WITH HEADLIGHT AUTO LEVELING SYSTEM)

SHORT CORD

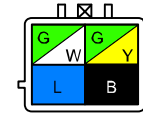

ANTILOCK BRAKE SYSTEM

0413-a

&5 : MZR-CD (RF Turbo)

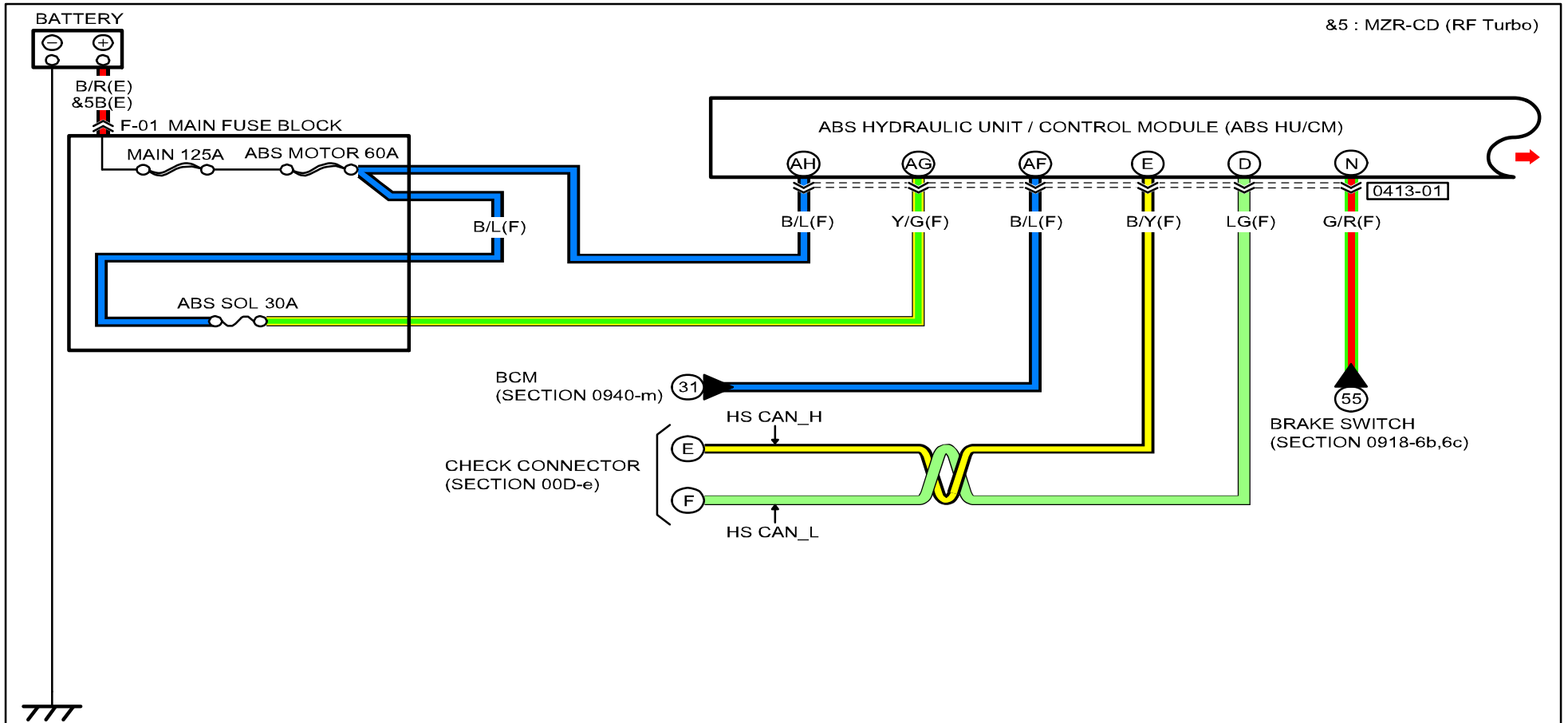

0413-01
ABS HU/CM

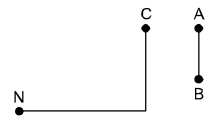
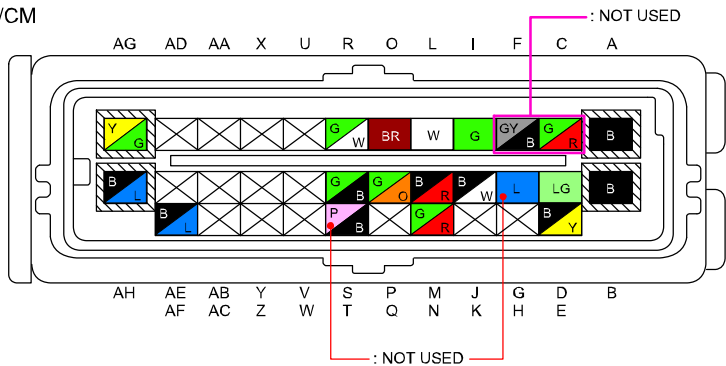

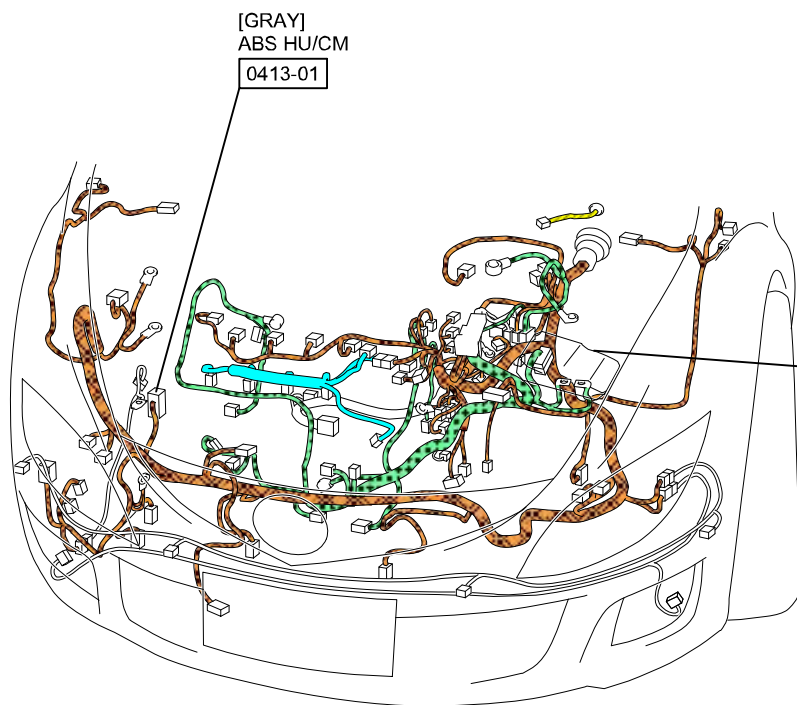



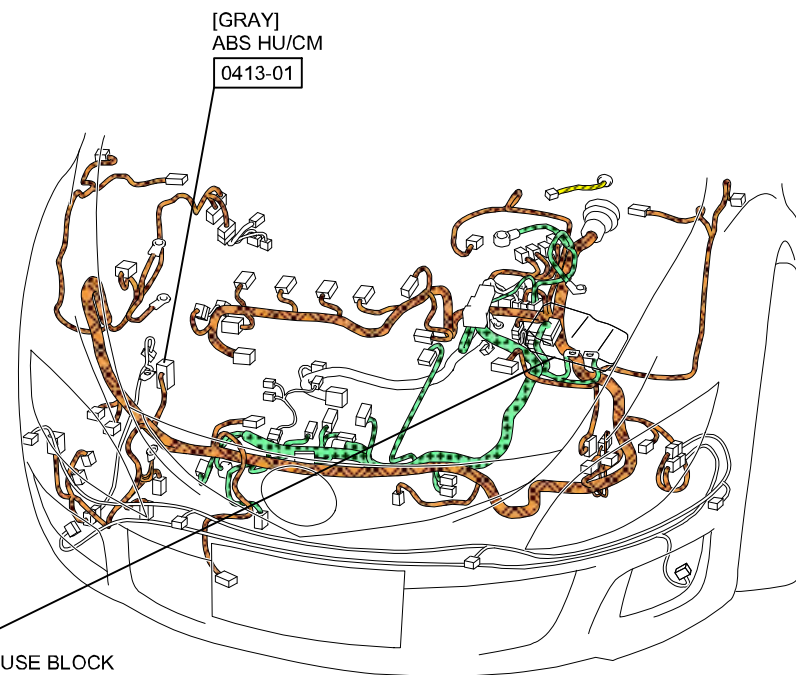

[EXCEPT MZR-CD (RF Turbo)]



[MZR-CD (RF Turbo)]

-  : FRONT HARNESS
-  : ENGINE HARNESS
-  : INJECTION HARNESS
-  : REAR HARNESS

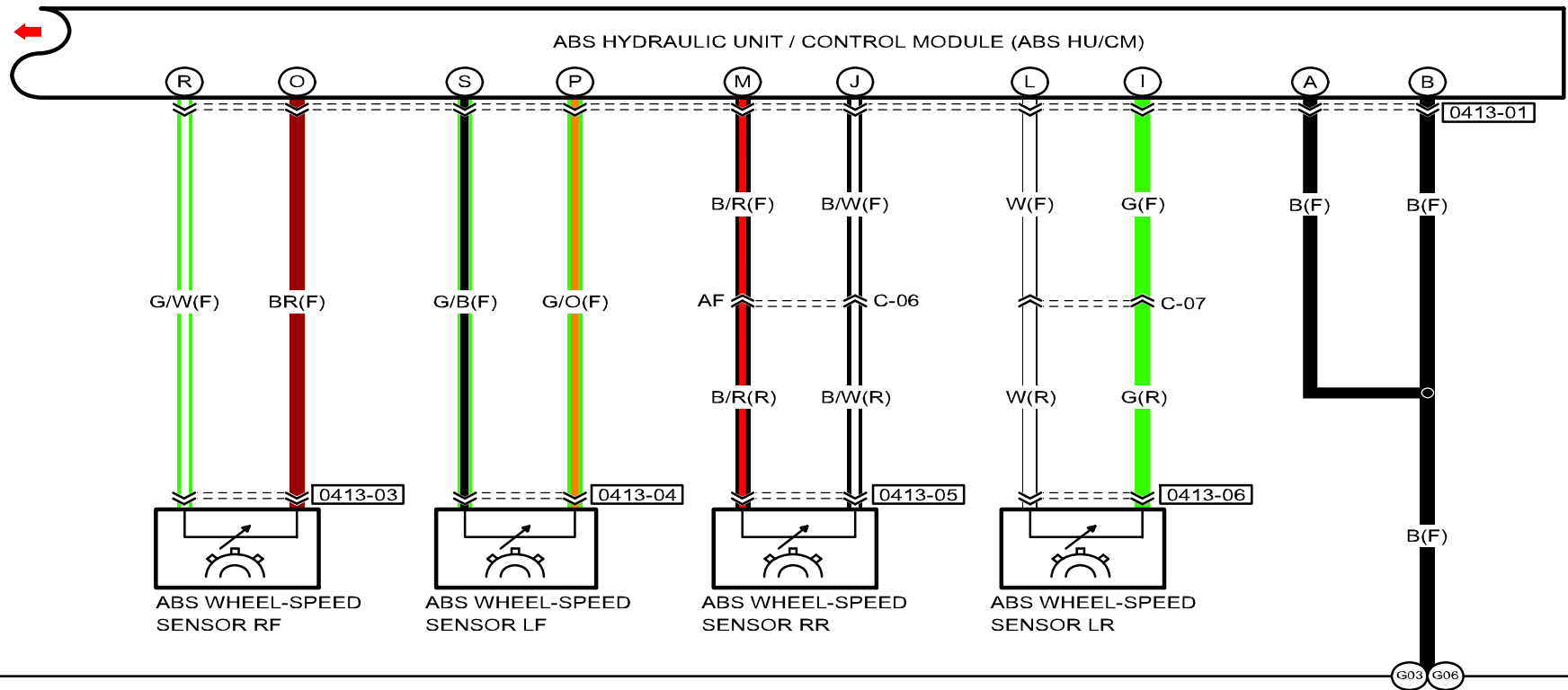

0413-01
ABS HU/CM

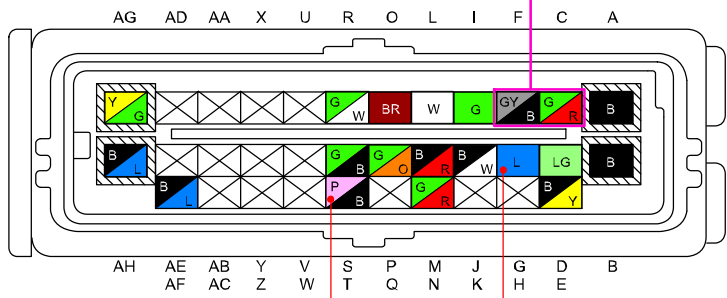

0413-03
ABS WHEEL-SPEED SENSOR RF

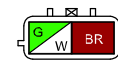

0413-05
ABS WHEEL-SPEED SENSOR RR

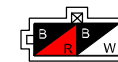

0413-04
ABS WHEEL-SPEED SENSOR LF

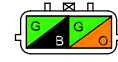

0413-06
ABS WHEEL-SPEED SENSOR LR

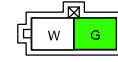

ANTILOCK BRAKE SYSTEM

0413-b

[GRAY]
ABS WHEEL-SPEED SENSOR RF
0413-03

[GRAY]
ABS HU/CM
0413-01

[GRAY]
ABS WHEEL-SPEED SENSOR LF
0413-04

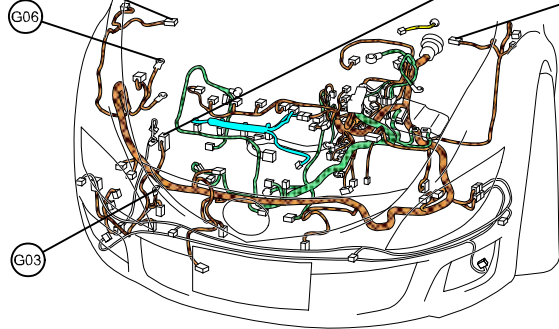

[EXCEPT MZR-CD (RF Turbo)]

[GRAY]
ABS WHEEL-SPEED SENSOR RF
0413-03

[GRAY]
ABS WHEEL-SPEED SENSOR LF
0413-04

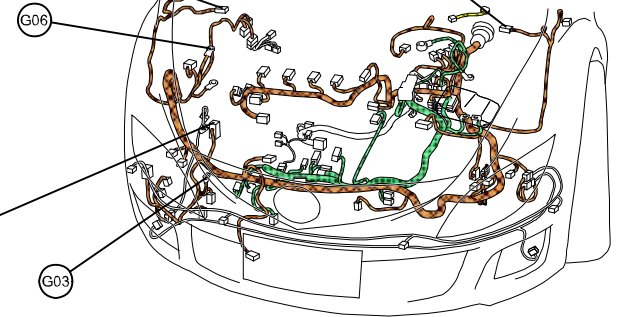

[MZR-CD (RF Turbo)]

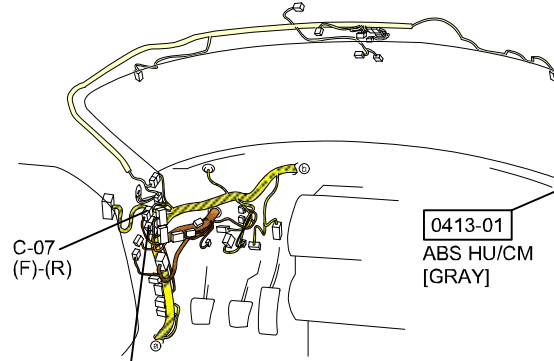

C-07
(F)-(R)

0413-01
ABS HU/CM
[GRAY]

C-06
(F)-(R)
[BLUE]

ABS WHEEL-SPEED SENSOR LR
0413-06

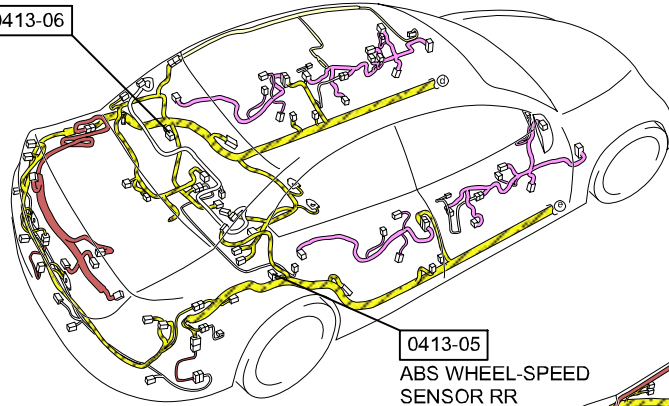

[4SD]

ABS WHEEL-SPEED SENSOR LR
0413-06

0413-05
ABS WHEEL-SPEED
SENSOR RR

ABS WHEEL-SPEED SENSOR LR
0413-06

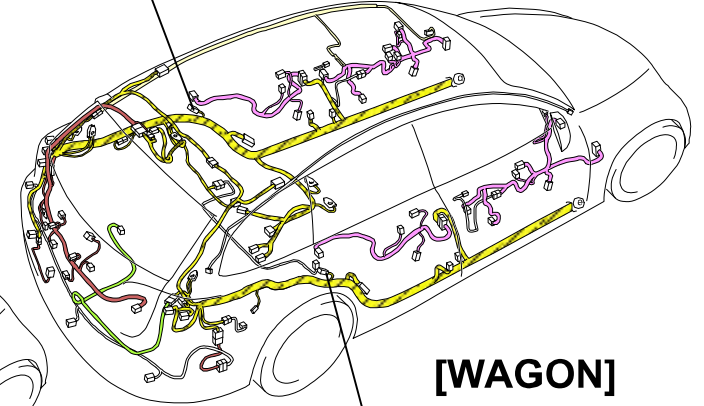





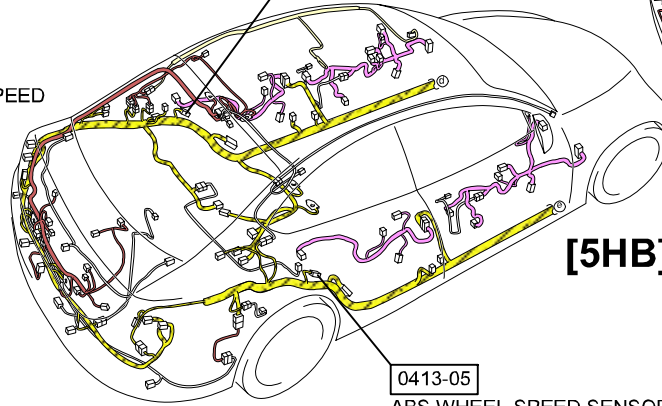





[WAGON]

0413-05
ABS WHEEL-SPEED SENSOR RR



[5HB]

0413-05
ABS WHEEL-SPEED SENSOR RR

-  : FRONT HARNESS
-  : ENGINE HARNESS
-  : INJECTION HARNESS
-  : REAR HARNESS
-  : REAR NO.2 HARNESS
-  : REAR NO.3 HARNESS
-  : REAR NO.4 HARNESS
-  : DOOR HARNESS
-  : INTERIOR LIGHT HARNESS
-  : INTERIOR LIGHT NO.2 HARNESS
-  : FLOOR HARNESS

&5 : MZR-CD (RF Turbo)

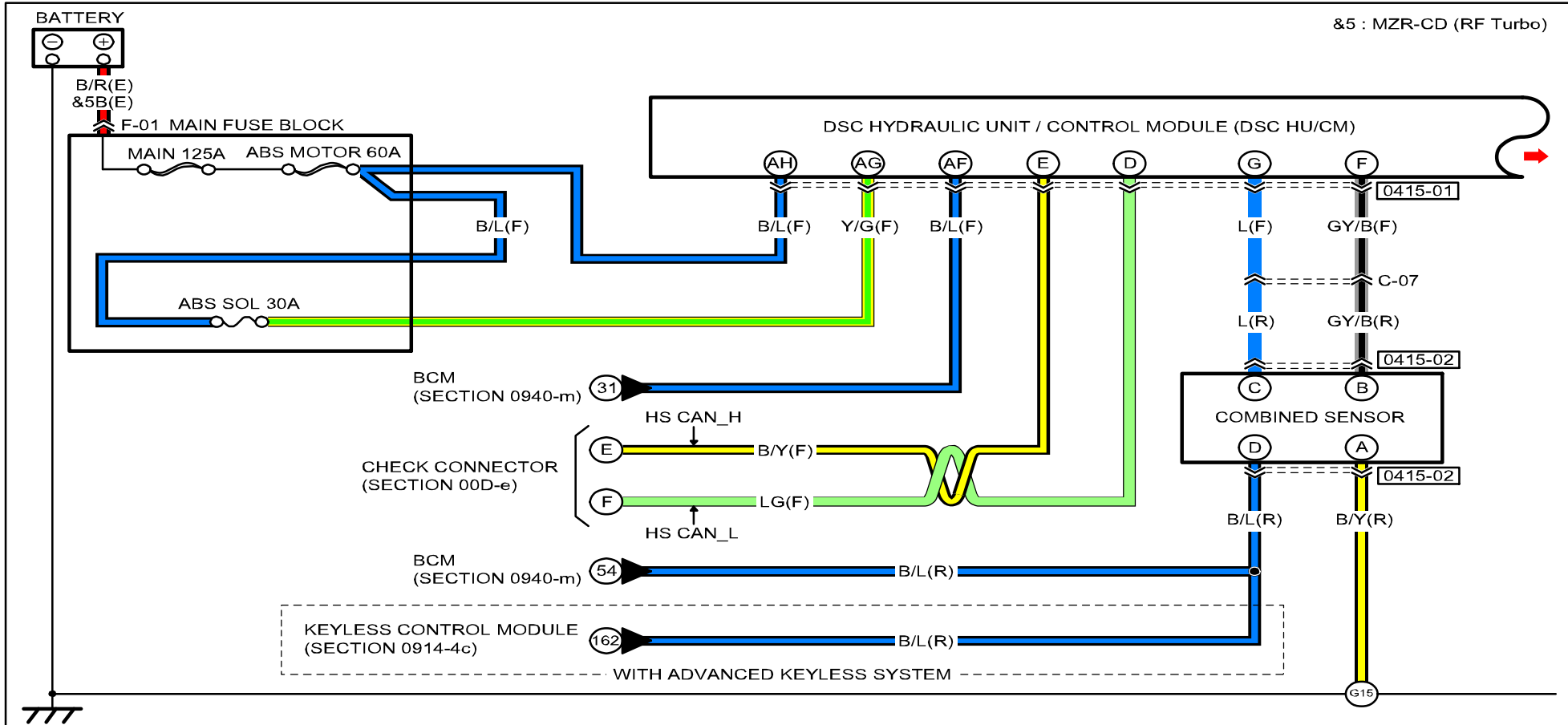

0415-01
DSC HU/CM

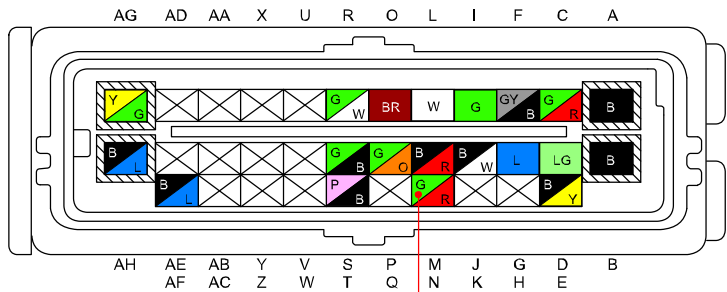

: NOT USED

0415-02
COMBINED SENSOR

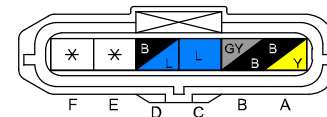

[GRAY]
DSC HU/CM
0415-01

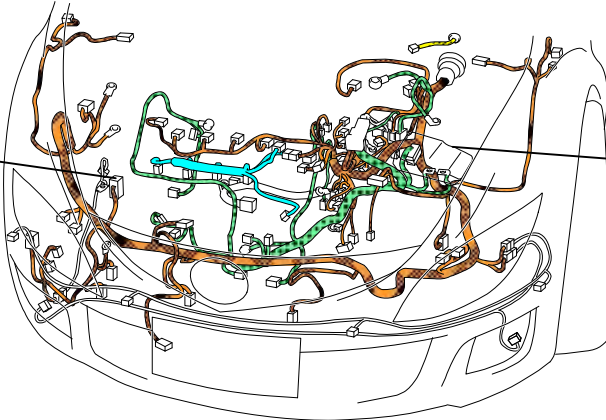

F-01
MAIN FUSE BLOCK
(REFER TO 00F SECTION)

[GRAY]
DSC HU/CM
0415-01

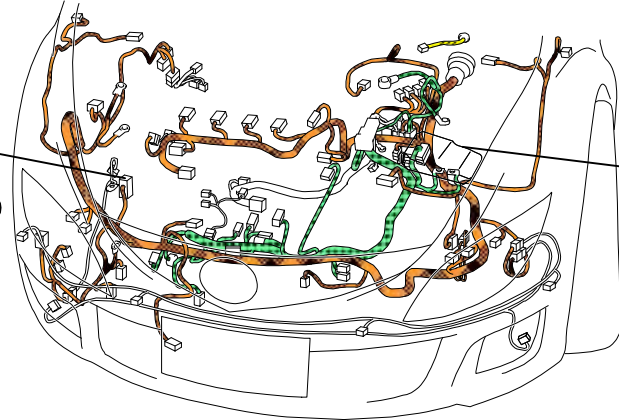







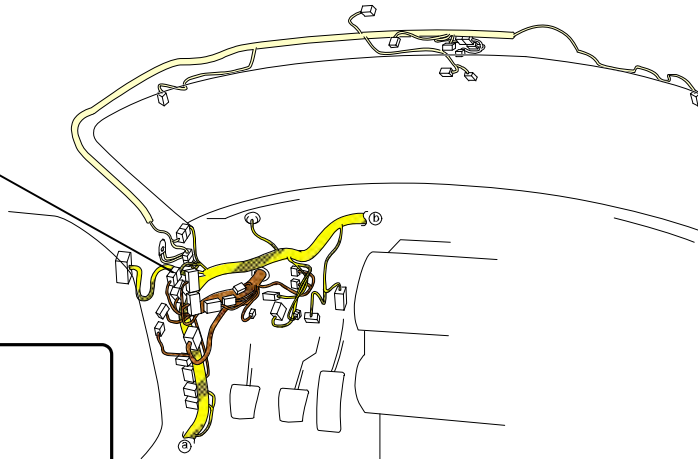

F-01
MAIN FUSE BLOCK
(REFER TO 00F SECTION)

[EXCEPT MZR-CD (RF Turbo)]

[MZR-CD (RF Turbo)]

(F)-(R)
C-07



-  : FRONT HARNESS
-  : ENGINE HARNESS
-  : INJECTION HARNESS
-  : REAR HARNESS
-  : REAR NO.5 HARNESS
-  : INSTRUMENT PANEL HARNESS
-  : FLOOR HARNESS
-  : INTERIOR LIGHT NO.2 HARNESS

G15

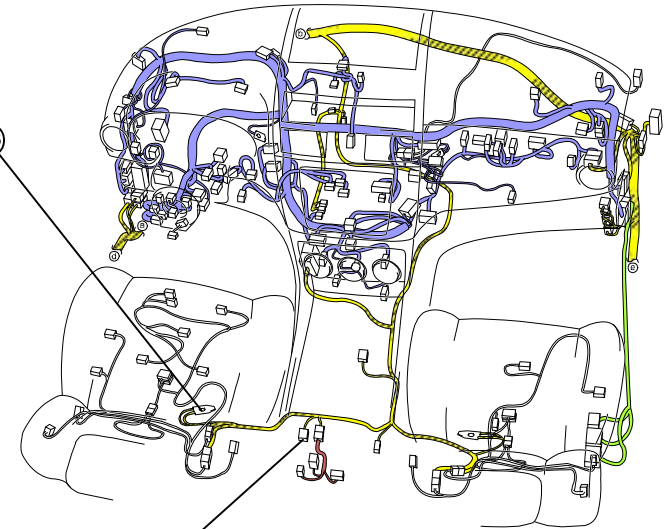

0415-02
COMBINED SENSOR
[BLACK]

C-07
FRONT HARNESS-REAR HARNESS

FRONT HARNESS

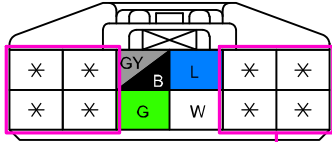

: WITH PARKING
SENSOR SYSTEM

REAR HARNESS

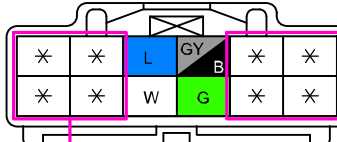

: WITH PARKING
SENSOR SYSTEM

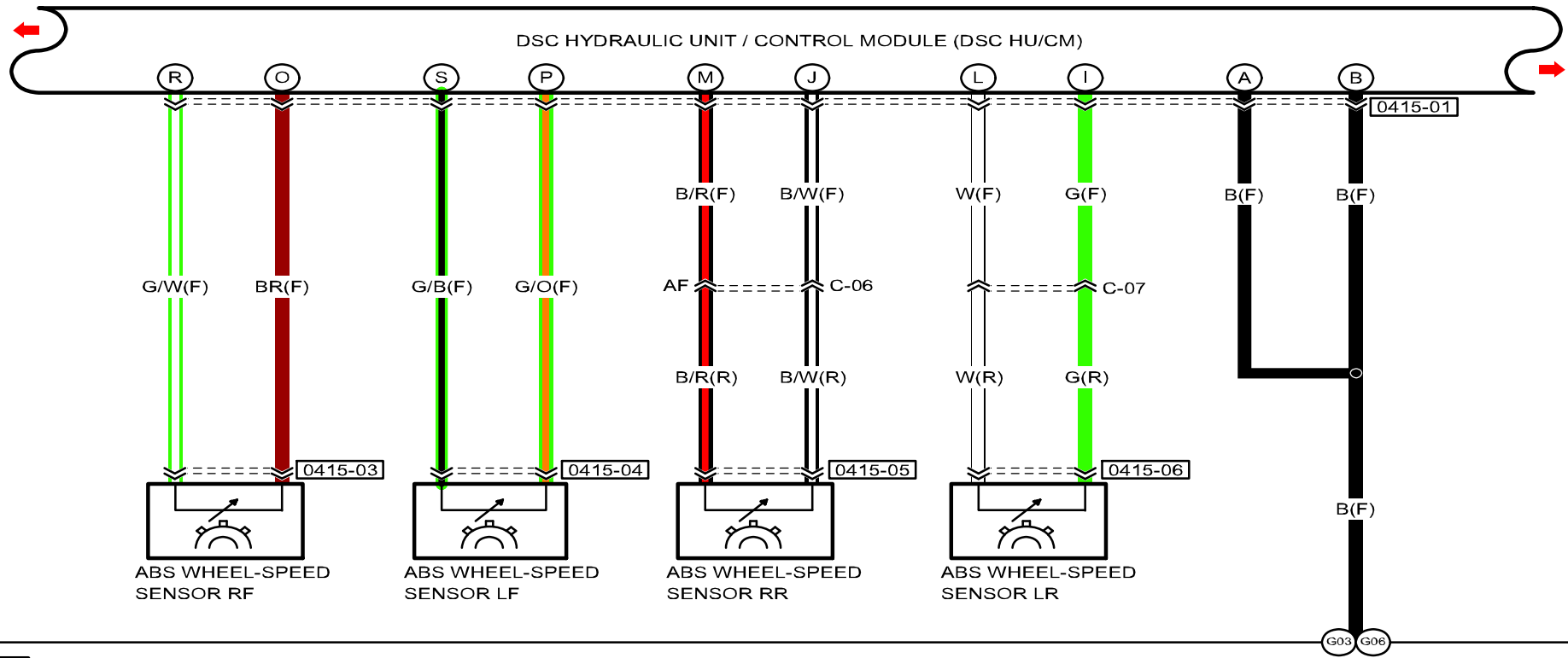

0415-01
DSC HU/CM

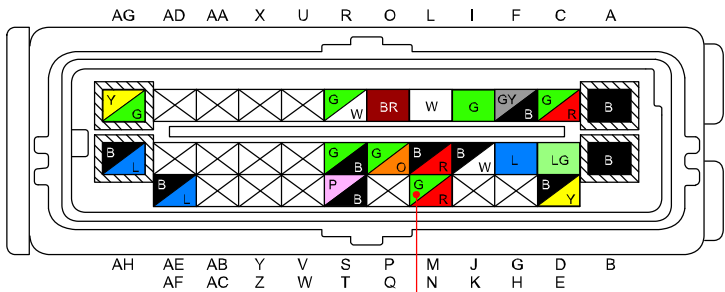

0415-03 ABS WHEEL-SPEED SENSOR RF	0415-05 ABS WHEEL-SPEED SENSOR RR	
0415-04 ABS WHEEL-SPEED SENSOR LF	0415-06 ABS WHEEL-SPEED SENSOR LR	

DYNAMIC STABILITY CONTROL

0415-b

[GRAY]
ABS WHEEL-SPEED SENSOR RF
0415-03

[GRAY]
DSC HU/CM
0415-01

[GRAY]
ABS WHEEL-SPEED SENSOR LF
0415-04

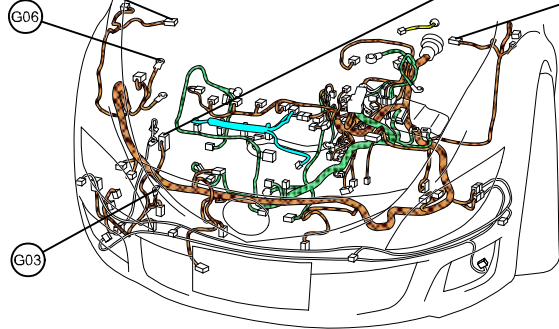

[EXCEPT MZR-CD (RF Turbo)]

[GRAY]
ABS WHEEL-SPEED SENSOR RF
0415-03

[GRAY]
ABS WHEEL-SPEED SENSOR LF
0415-04

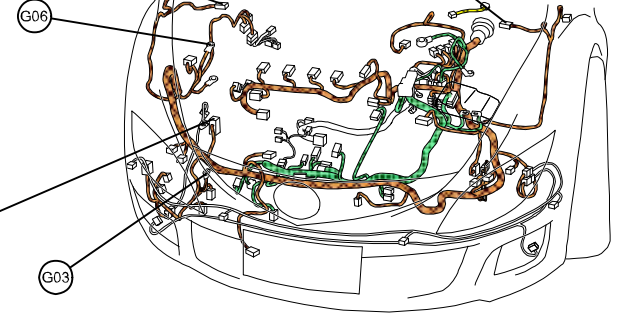

[MZR-CD (RF Turbo)]

C-07
(F)-(R)

0415-01
DSC HU/CM
[GRAY]

C-06
(F)-(R)
[BLUE]

ABS WHEEL-SPEED SENSOR LR
0415-06

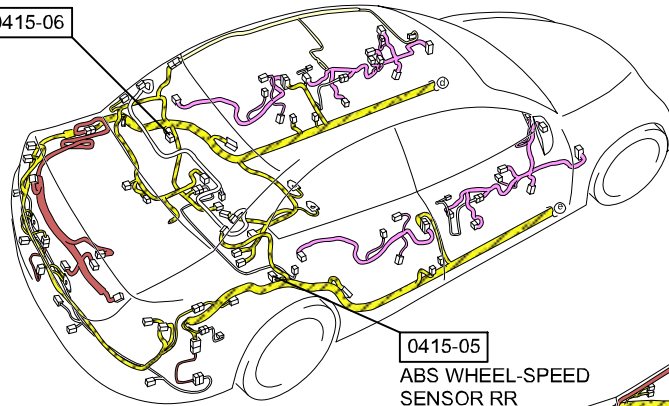

[4SD]

ABS WHEEL-SPEED SENSOR LR
0415-06

0415-05
ABS WHEEL-SPEED
SENSOR RR

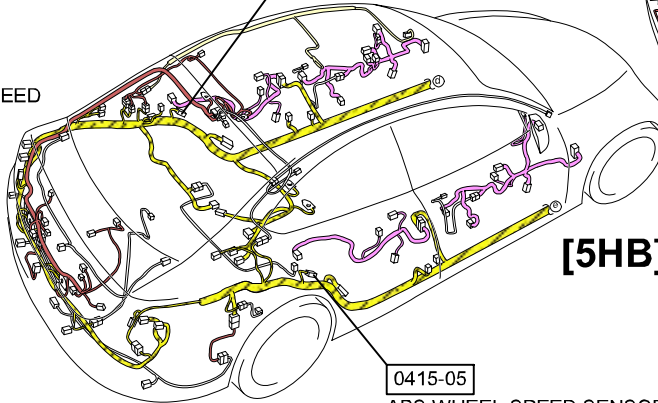

[5HB]





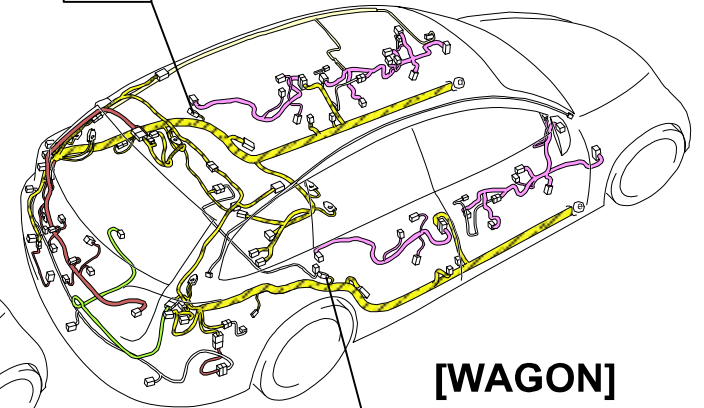





0415-05
ABS WHEEL-SPEED SENSOR RR

ABS WHEEL-SPEED SENSOR LR
0415-06



[WAGON]

0415-05
ABS WHEEL-SPEED SENSOR RR

-  : FRONT HARNESS
-  : ENGINE HARNESS
-  : INJECTION HARNESS
-  : REAR HARNESS
-  : REAR NO.2 HARNESS
-  : REAR NO.3 HARNESS
-  : REAR NO.4 HARNESS
-  : DOOR HARNESS
-  : INTERIOR LIGHT HARNESS
-  : INTERIOR LIGHT NO.2 HARNESS
-  : FLOOR HARNESS

C-06

FRONT HARNESS-REAR HARNESS

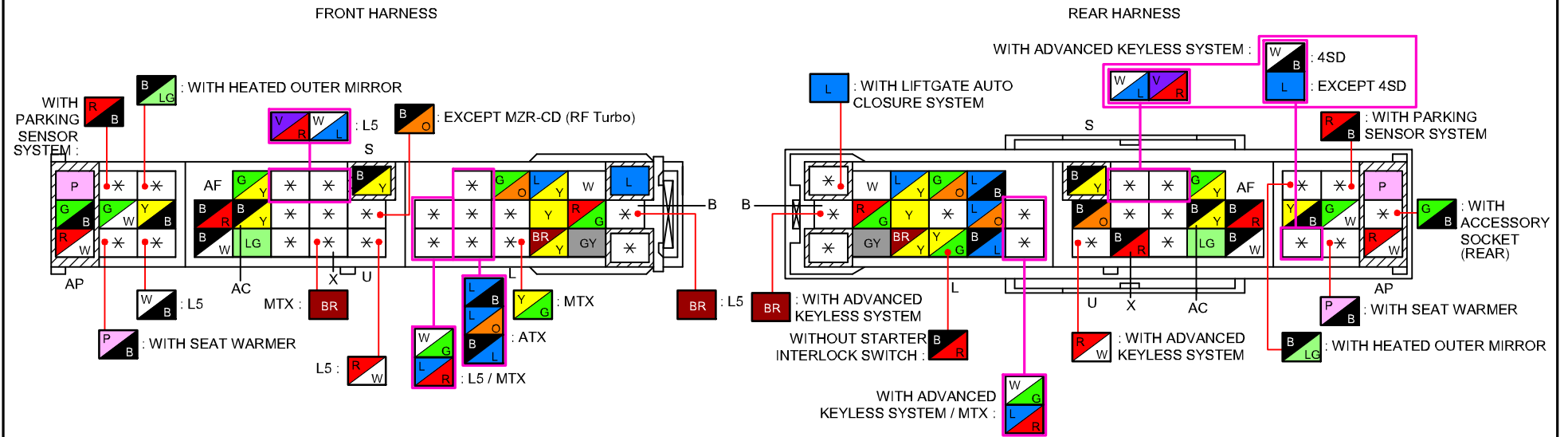

C-07

FRONT HARNESS-REAR HARNESS

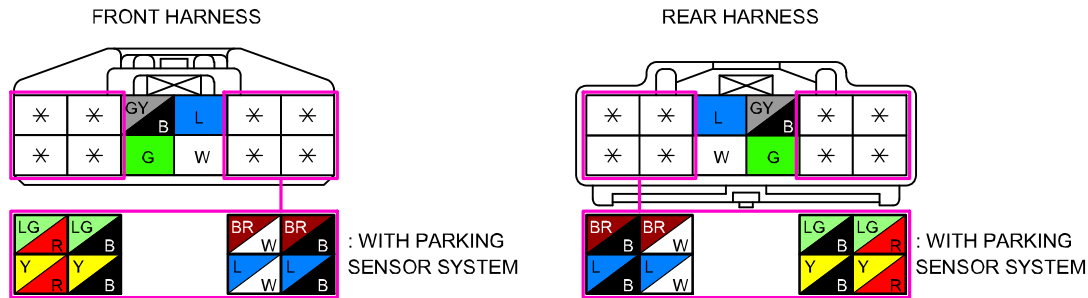

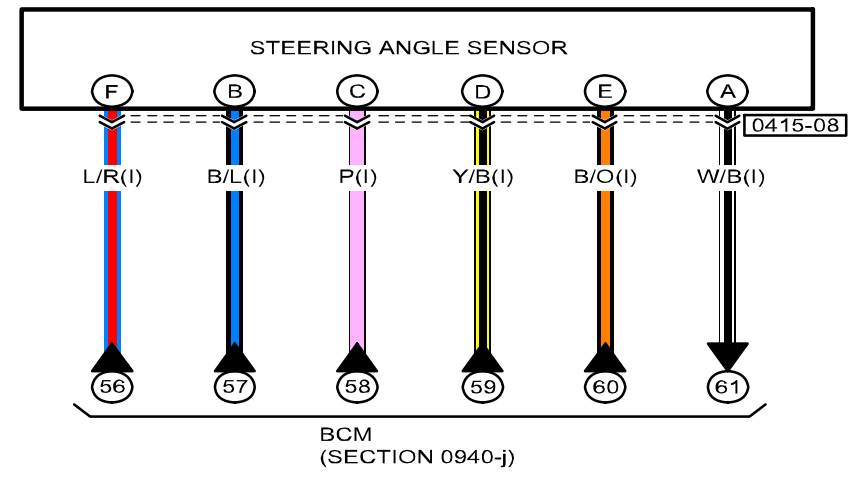
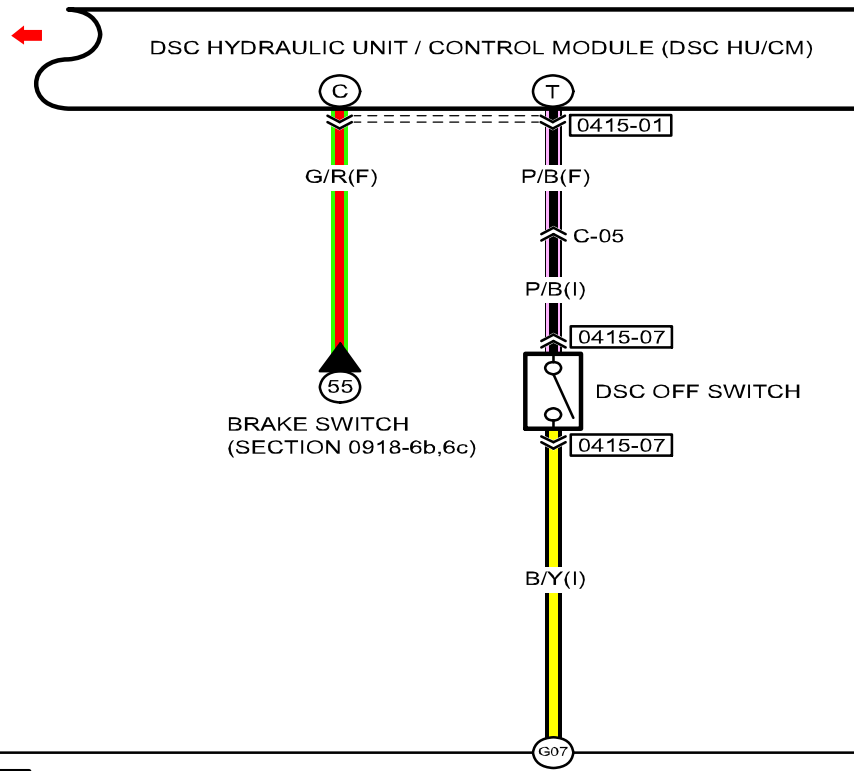

0415-01
DSC HU/CM

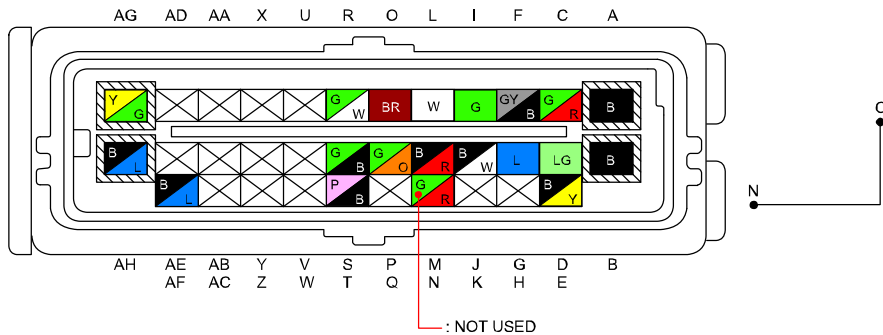

0415-07
DSC OFF SWITCH /
AFS OFF SWITCH /
HEADLIGHT LEVELING SWITCH /
DSC OFF SWITCH ILLUMINATION /
AFS OFF SWITCH ILLUMINATION /
HEADLIGHT LEVELING SWITCH ILLUMINATION

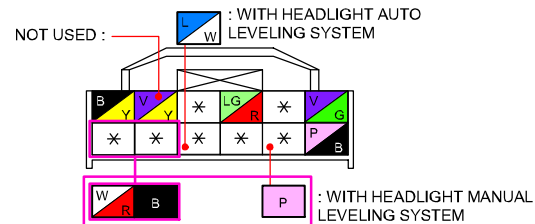

0415-08
STEERING ANGLE SENSOR

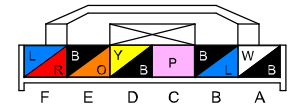

[GRAY]
DSC HU/CM
0415-01

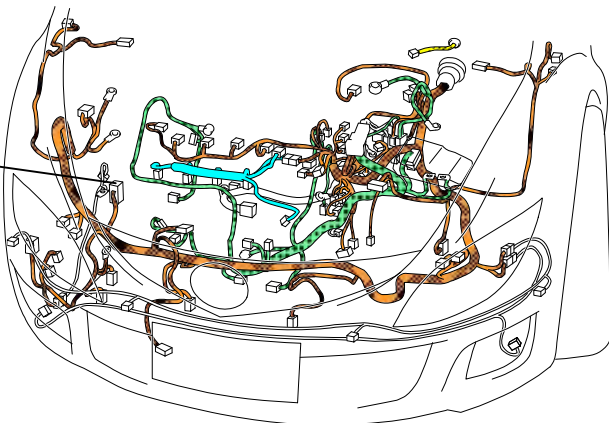

[EXCEPT MZR-CD (RF Turbo)]

[GRAY]
DSC HU/CM
0415-01

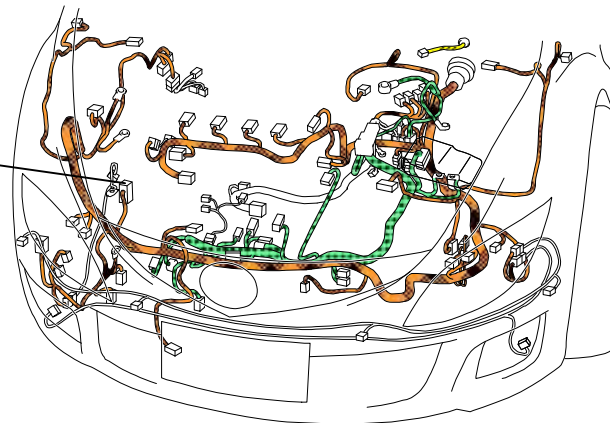







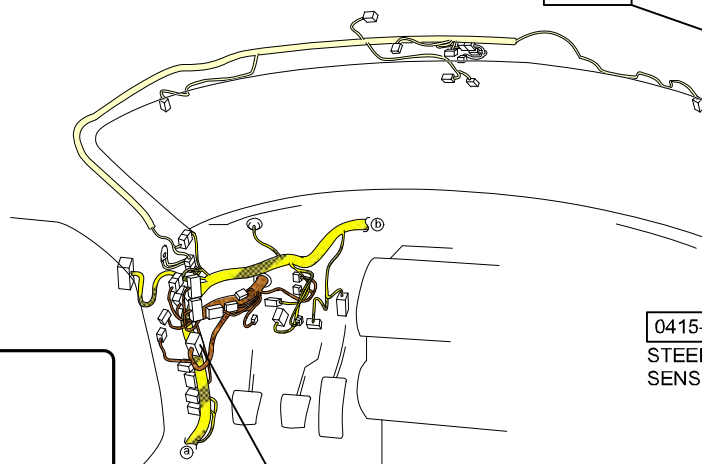

[MZR-CD (RF Turbo)]

DSC OFF SWITCH /
AFS OFF SWITCH /
HEADLIGHT LEVELING SWITCH /
DSC OFF SWITCH ILLUMINATION /
AFS OFF SWITCH ILLUMINATION /
HEADLIGHT LEVELING SWITCH ILLUMINATION
0415-07

[BLUE]
(F)-(I)
C-05



C-05
(F)-(I)
[BLUE]

-  : FRONT HARNESS
-  : ENGINE HARNESS
-  : INJECTION HARNESS
-  : REAR HARNESS
-  : REAR NO.5 HARNESS
-  : INSTRUMENT PANEL HARNESS
-  : FLOOR HARNESS
-  : INTERIOR LIGHT NO.2 HARNESS

0415-08
STEERING ANGLE
SENSOR

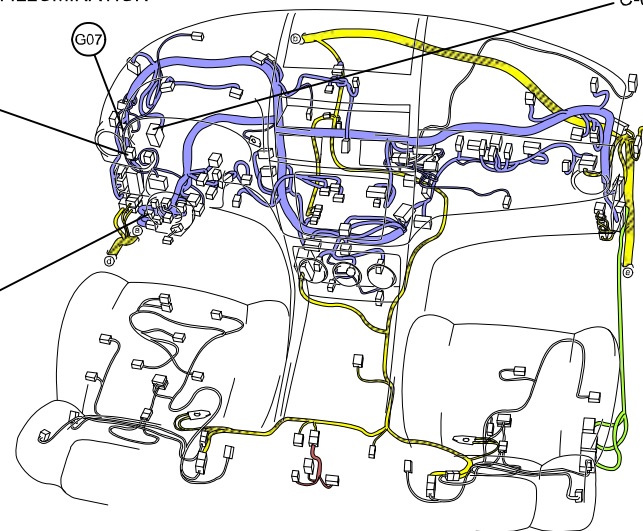

G07

C-05

FRONT HARNESS-INSTRUMENT PANEL HARNESS

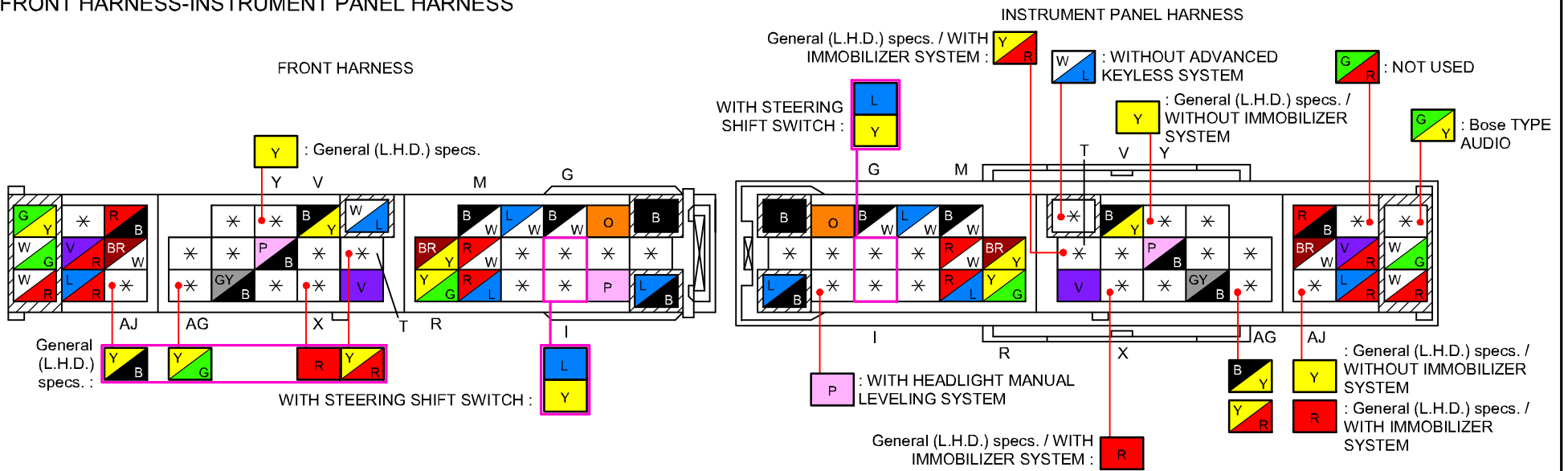

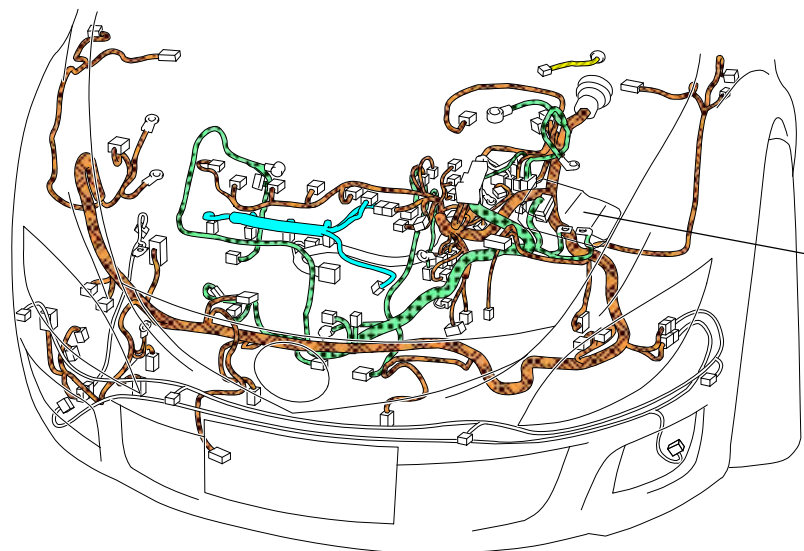



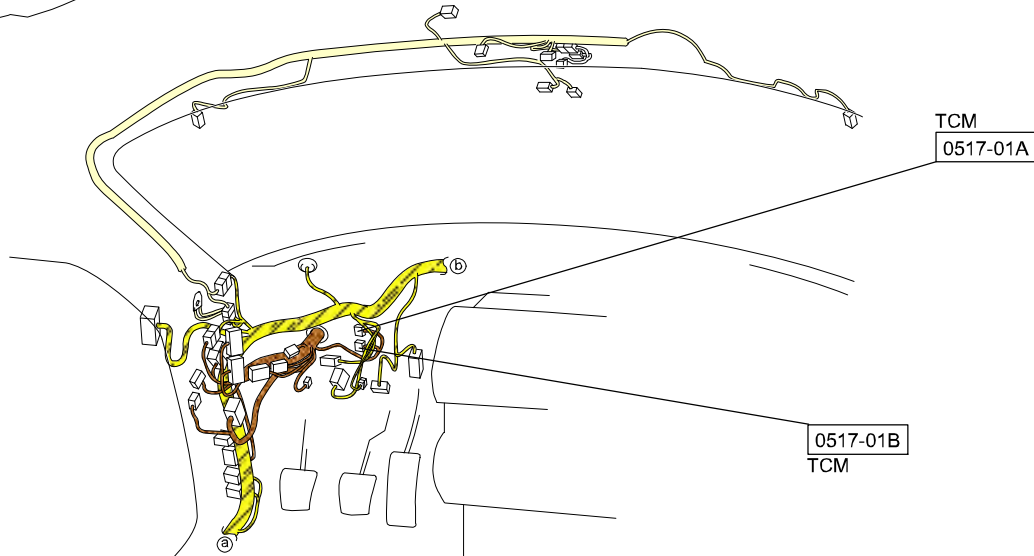

F-01
MAIN FUSE BLOCK
(REFER TO 00F SECTION)



TCM
0517-01A

0517-01B
TCM

-  : FRONT HARNESS
-  : ENGINE HARNESS
-  : INJECTION HARNESS
-  : REAR HARNESS
-  : INTERIOR LIGHT NO.2 HARNESS

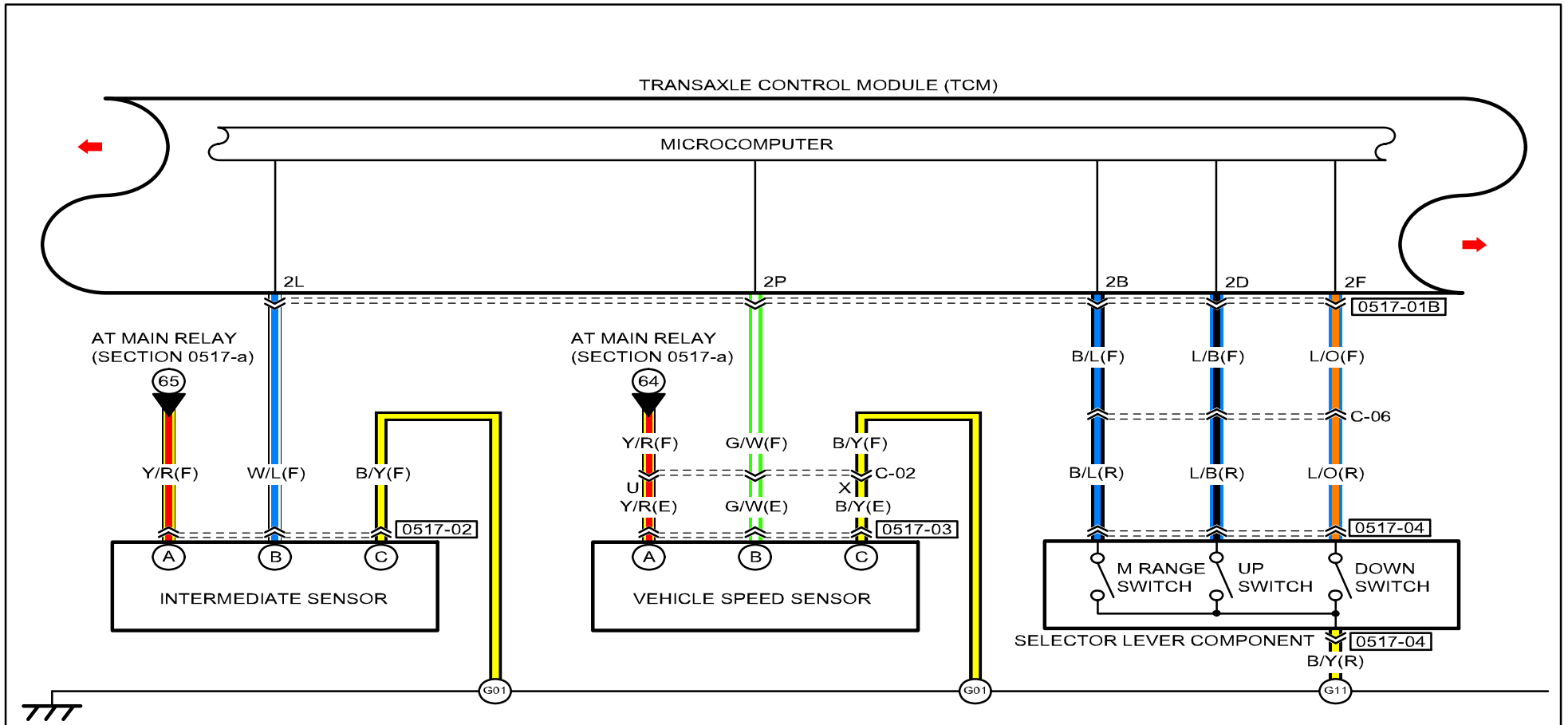

<p>0517-01B TCM</p> <p>2W 2U 2S 2Q 2O 2M 2K 2I 2G 2E 2C 2A 2X 2V 2T 2R 2P 2N 2L 2J 2H 2F 2D 2B</p> <p>L : WITH STEERING SHIFT SWITCH Y : WITH STEERING SHIFT SWITCH</p>	<p>0517-02 INTERMEDIATE SENSOR</p>	<p>0517-03 VEHICLE SPEED SENSOR</p>	<p>0517-04 SELECTOR LEVER COMPONENT / SELECTOR ILLUMINATION</p>

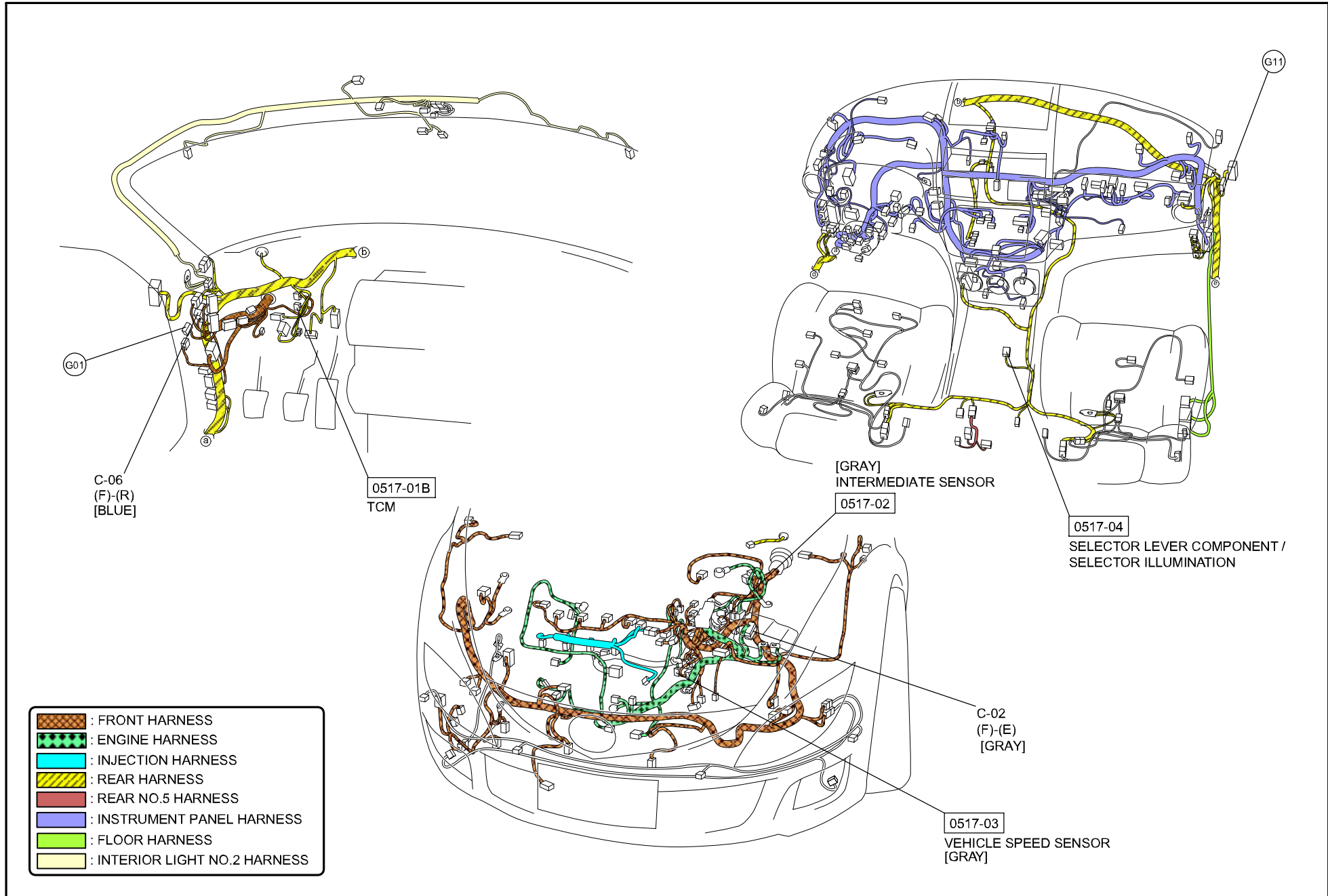

- : FRONT HARNESS
- : ENGINE HARNESS
- : INJECTION HARNESS
- : REAR HARNESS
- : REAR NO.5 HARNESS
- : INSTRUMENT PANEL HARNESS
- : FLOOR HARNESS
- : INTERIOR LIGHT NO.2 HARNESS

C-02
FRONT HARNESS-ENGINE HARNESS

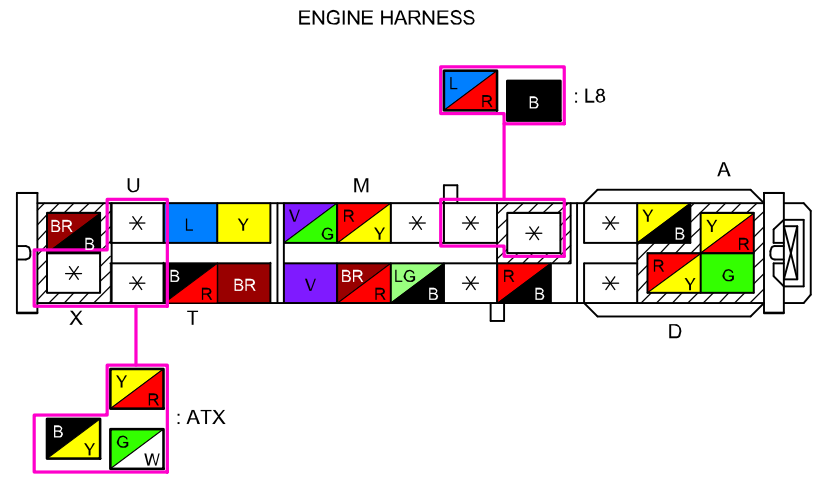
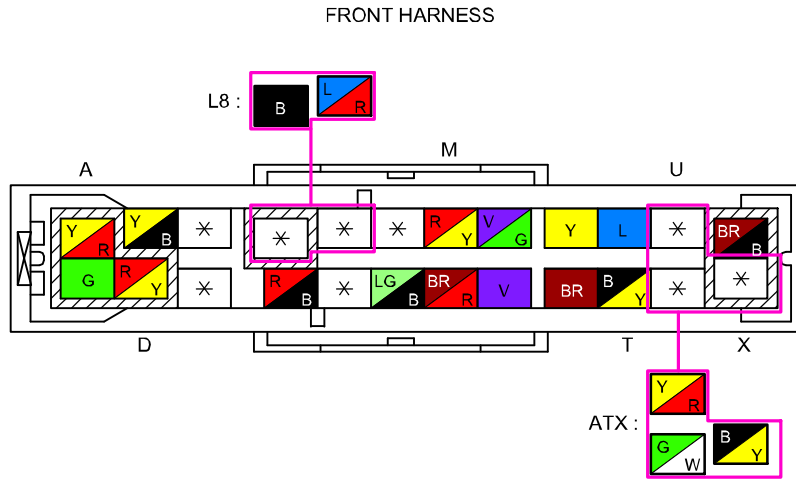

(EXCEPT MZR-CD (RF Turbo))

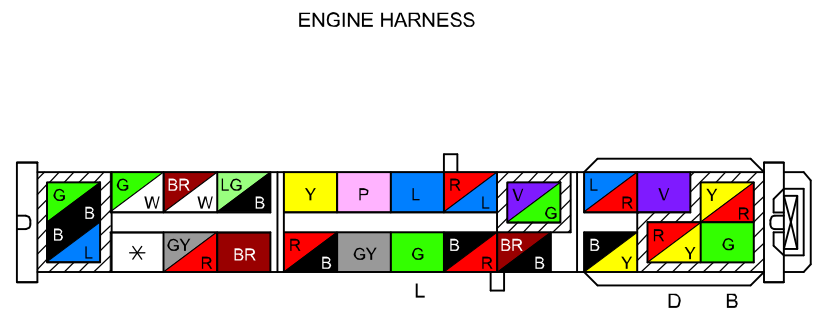
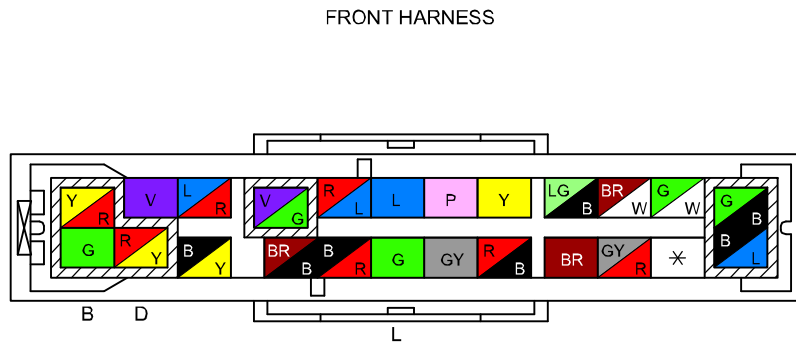

(MZR-CD (RF Turbo))

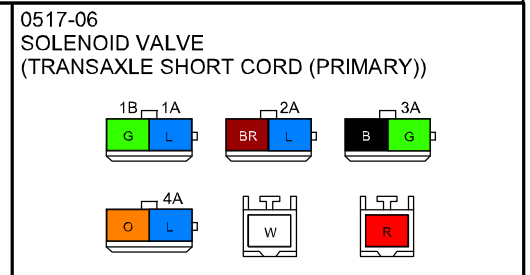
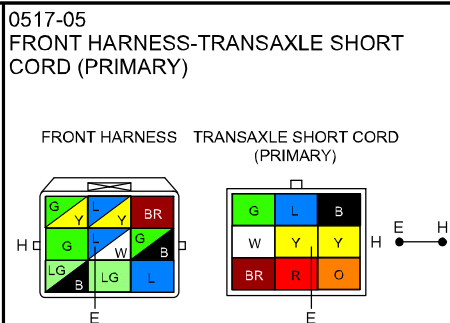
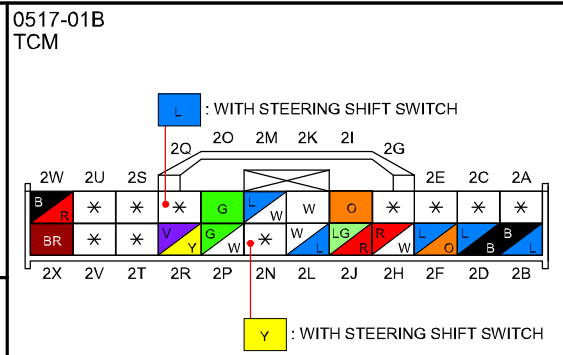
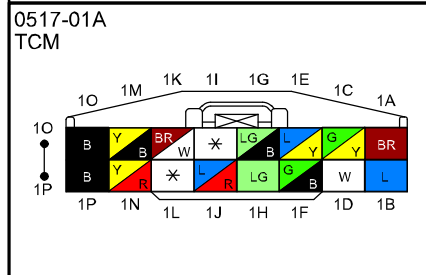
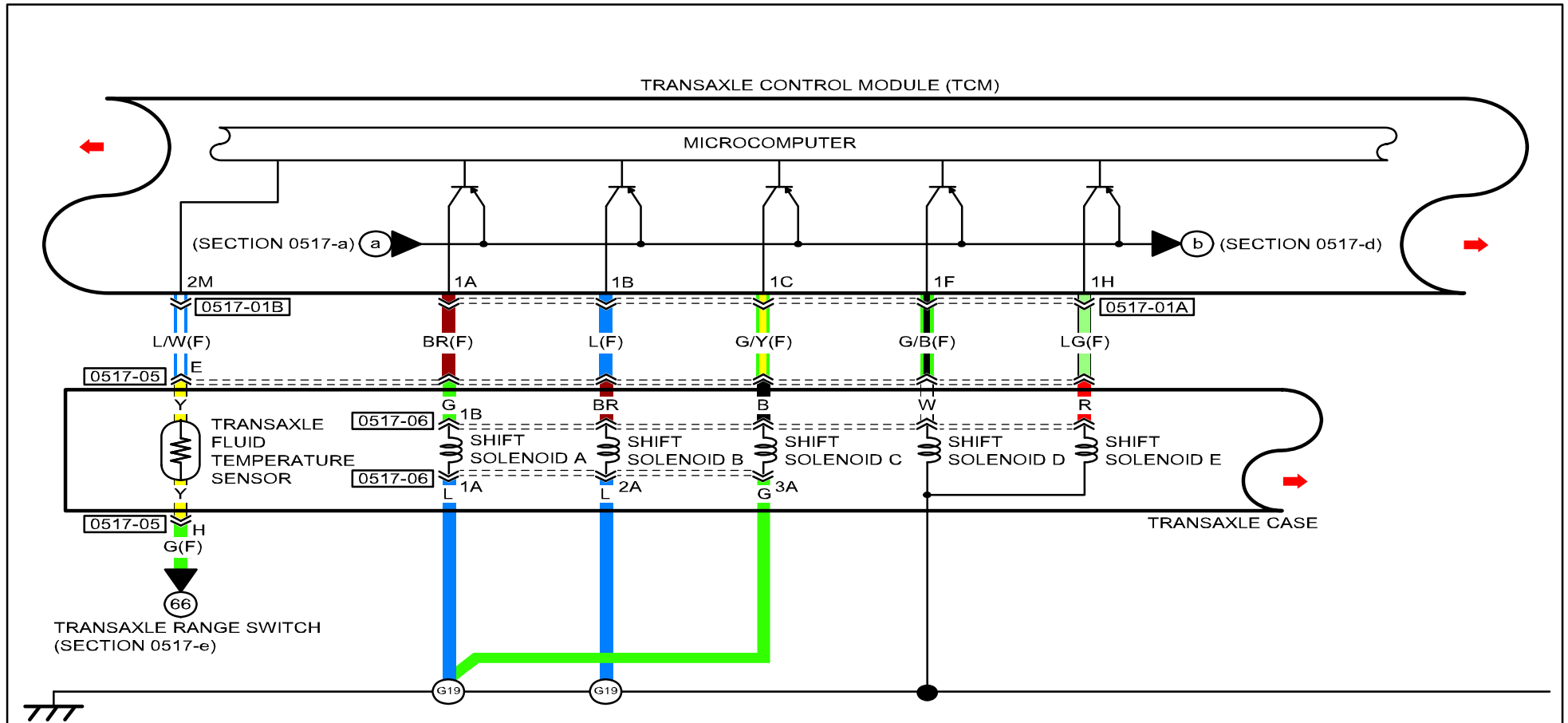

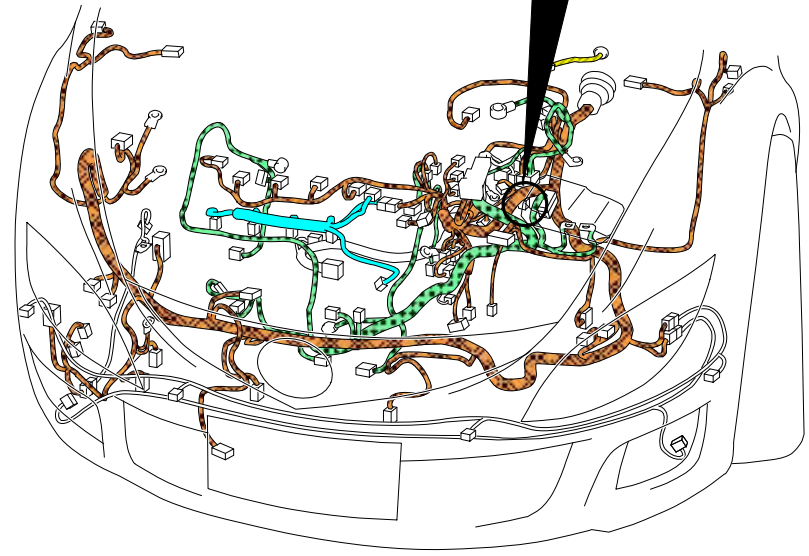
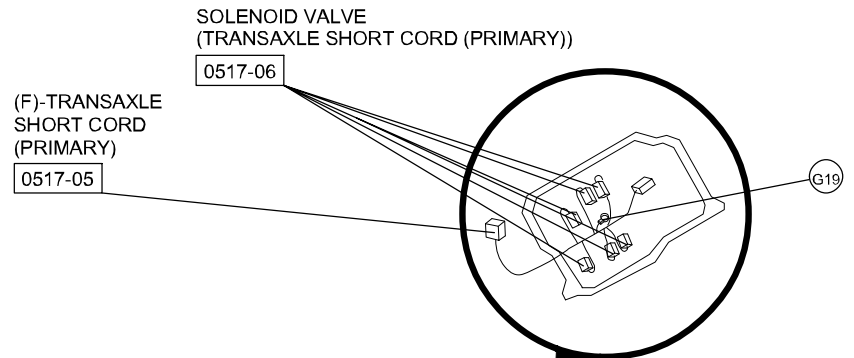
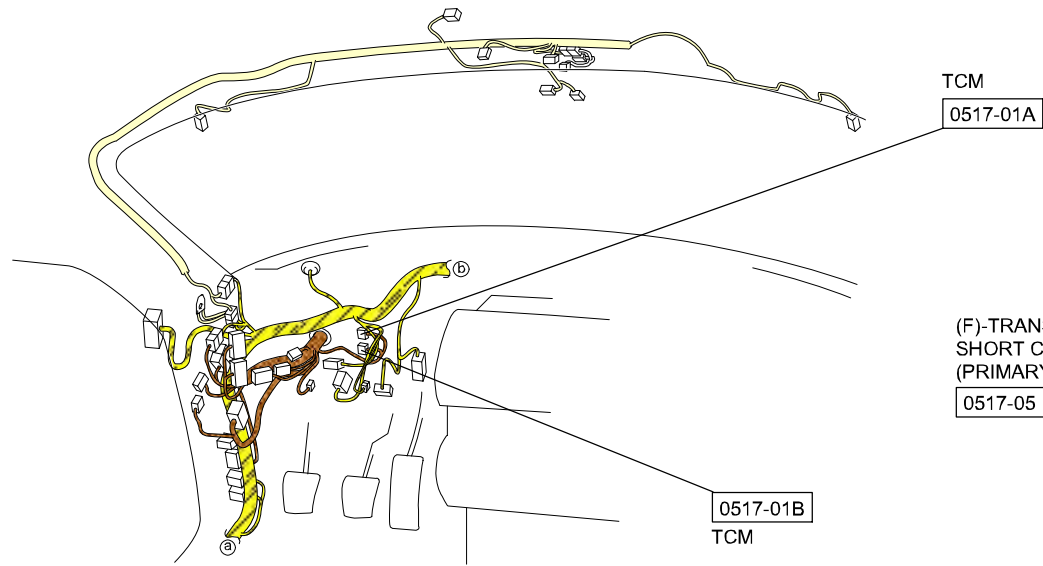

- FRONT HARNESS
- ENGINE HARNESS
- INJECTION HARNESS
- REAR HARNESS
- INTERIOR LIGHT NO.2 HARNESS

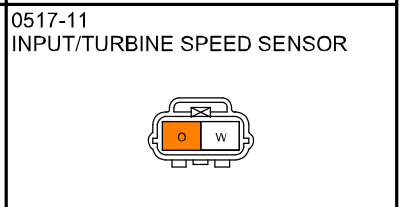
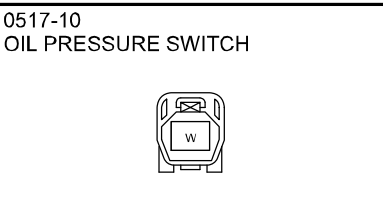
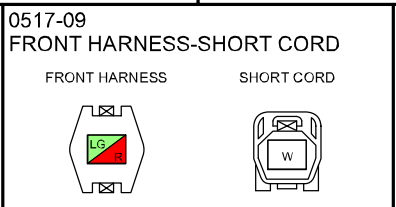
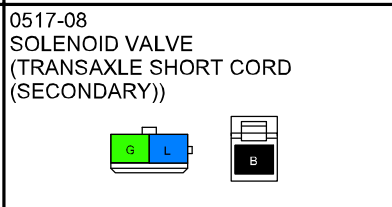
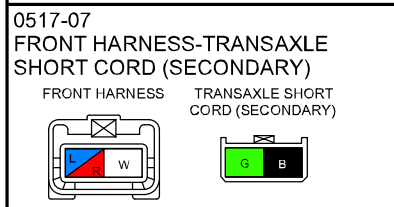
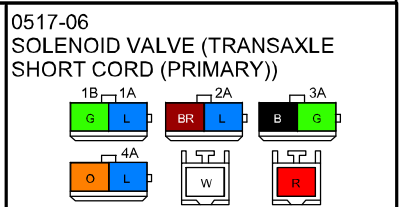
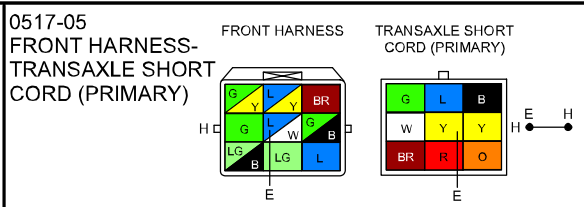
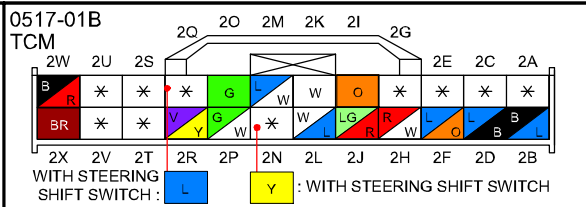
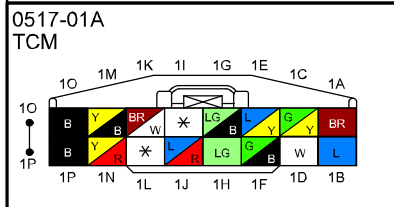
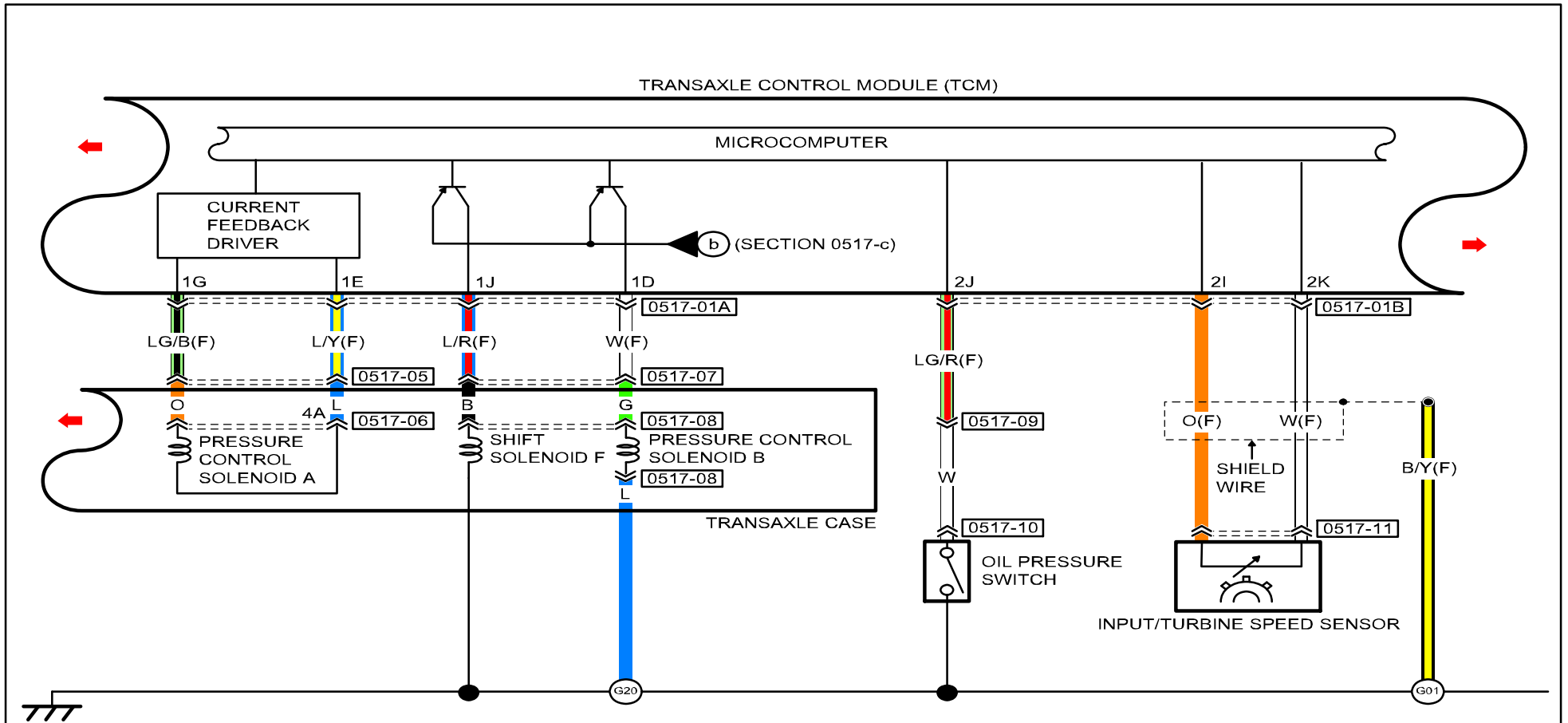

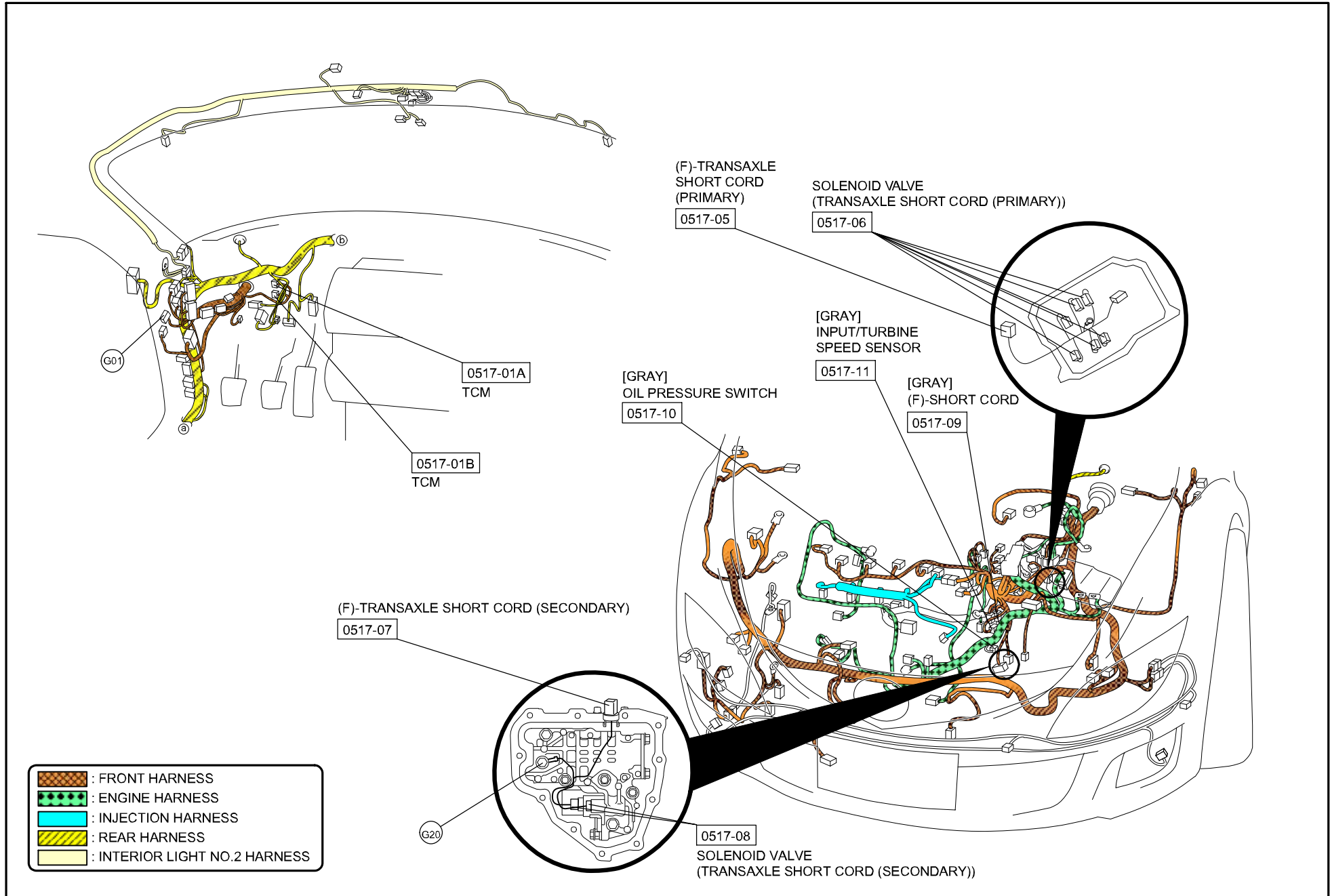

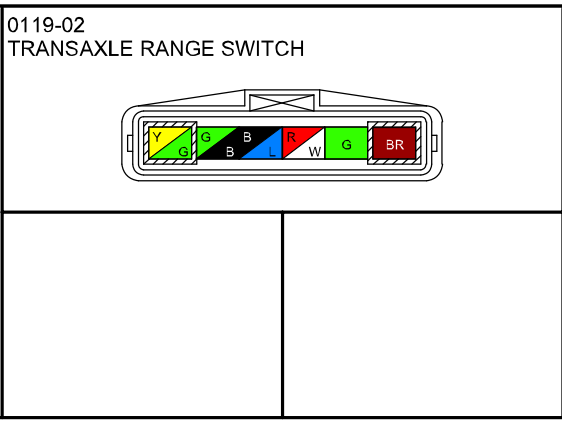
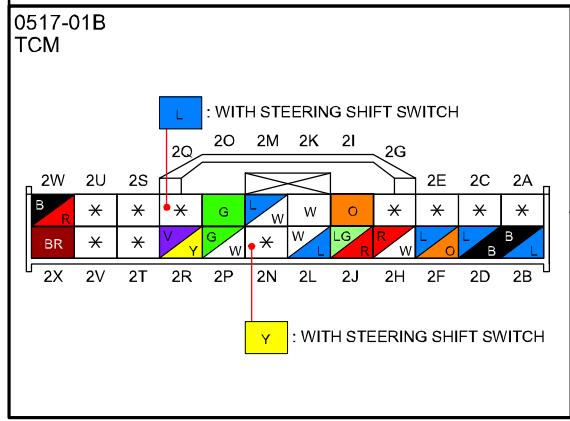
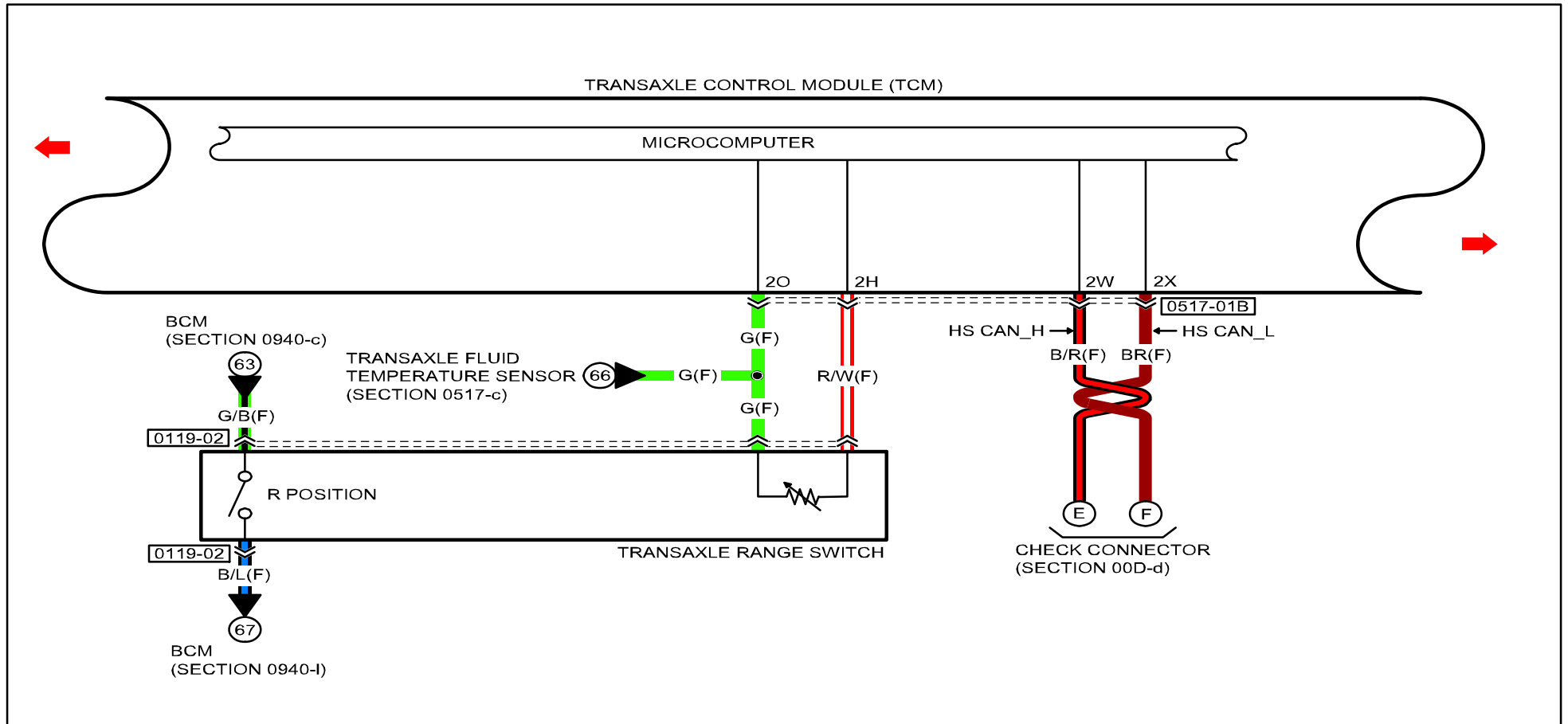

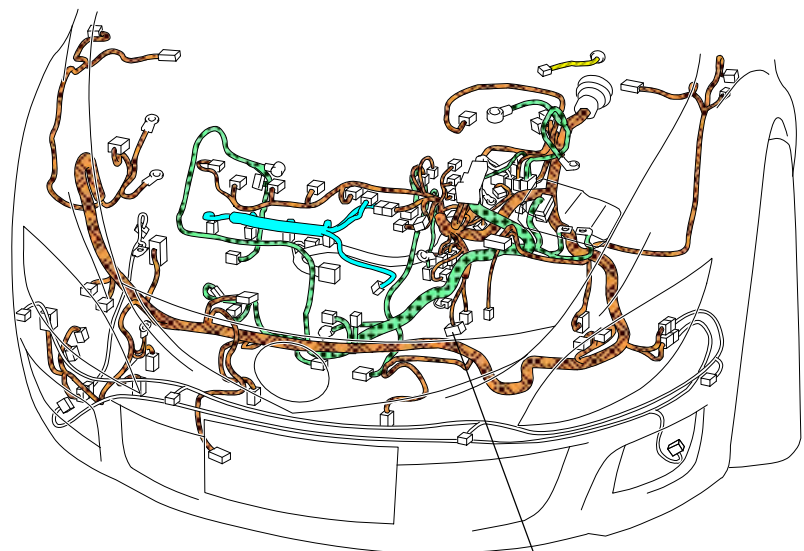



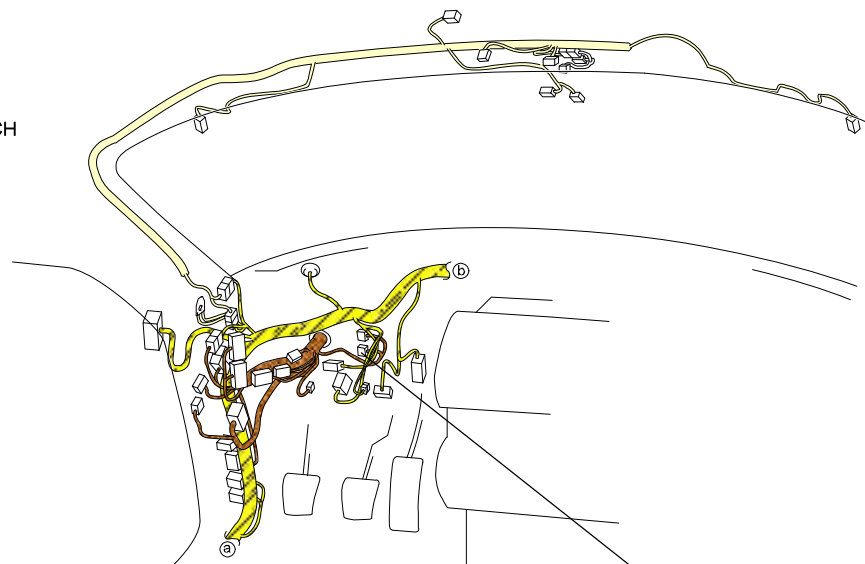



0119-02
TRANSAXLE RANGE SWITCH
[BLACK]



0517-01B
TCM

-  : FRONT HARNESS
-  : ENGINE HARNESS
-  : INJECTION HARNESS
-  : REAR HARNESS
-  : INTERIOR LIGHT NO.2 HARNESS

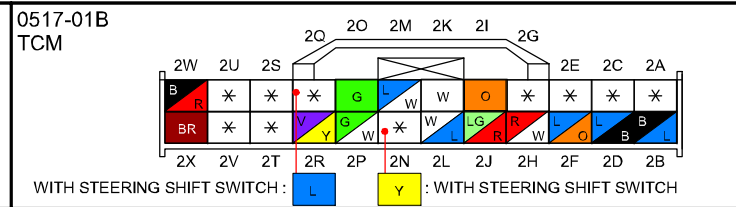
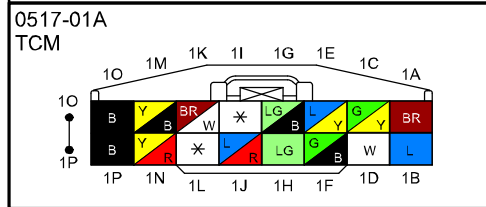
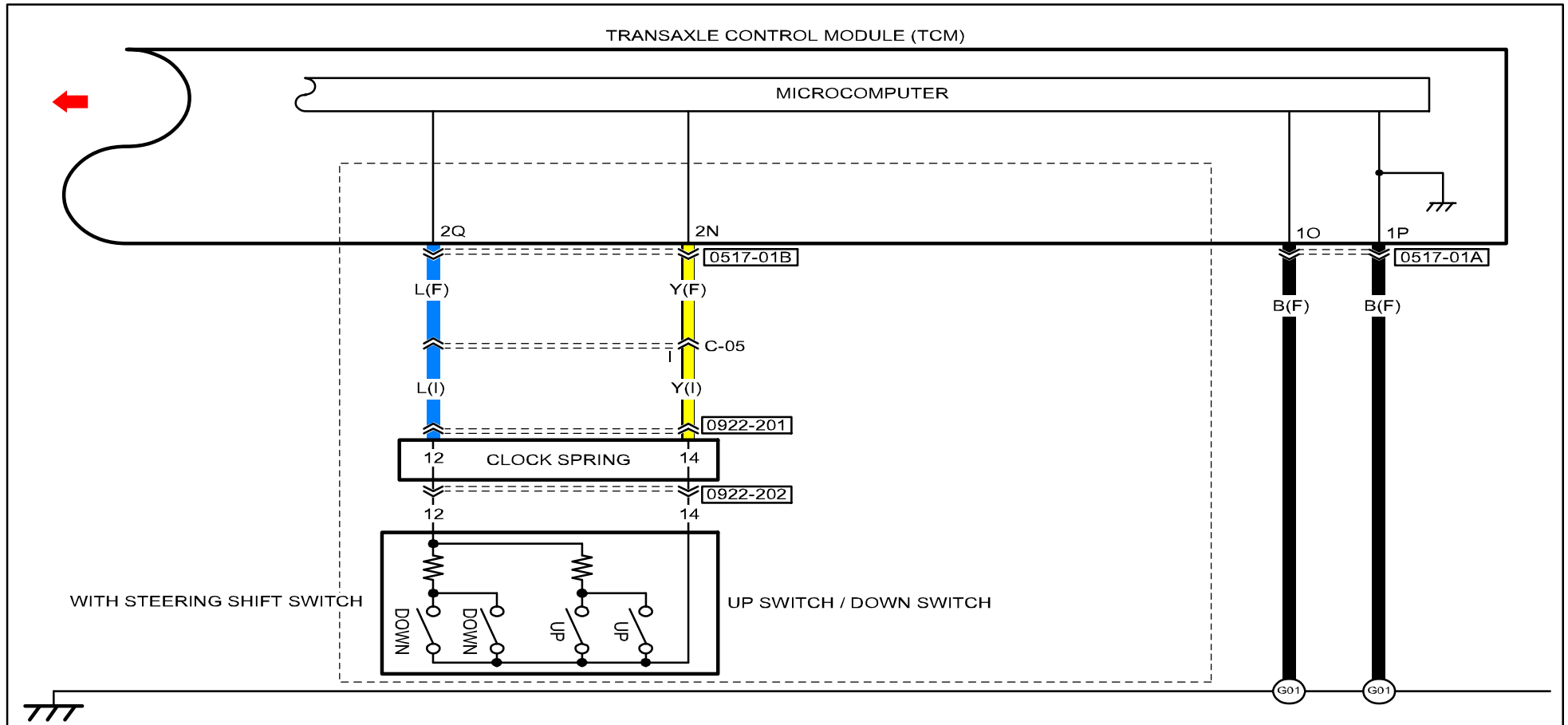

0922-202
CRUISE CONTROL SWITCH /
UP SWITCH / DOWN SWITCH /
STEERING SWITCH ILLUMINATION /
UP SWITCH ILLUMINATION /
DOWN SWITCH ILLUMINATION /
CRUISE CONTROL SWITCH ILLUMINATION /
STEERING SWITCH /
CLOCK SPRING

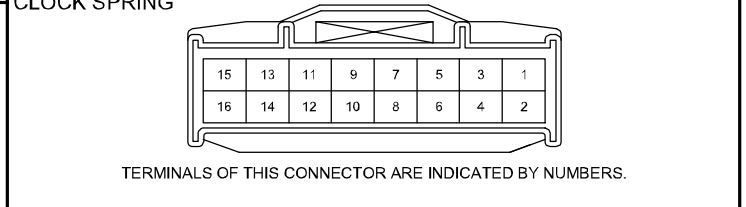
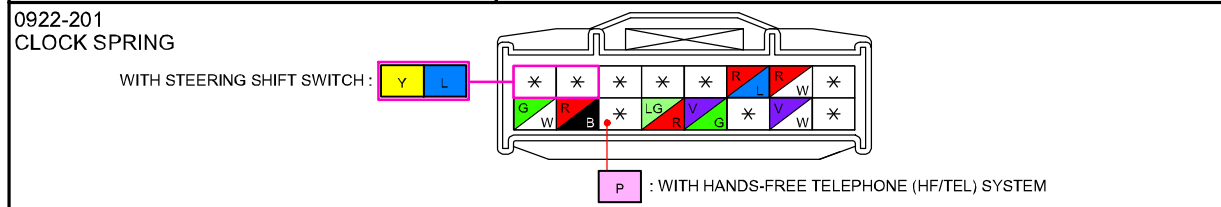

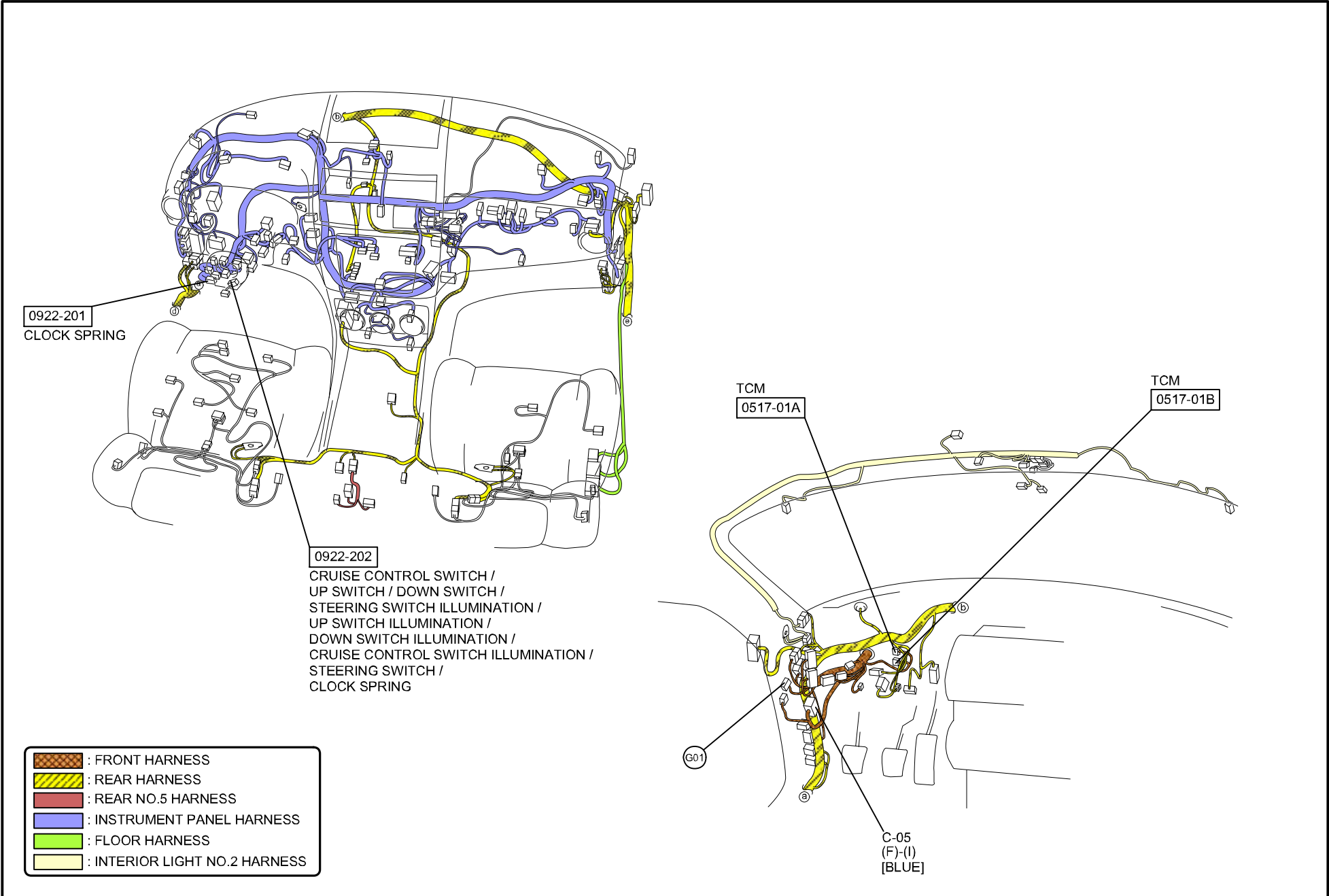

EC-AT CONTROL SYSTEM

C-05
FRONT HARNESS-INSTRUMENT PANEL HARNESS

FRONT HARNESS

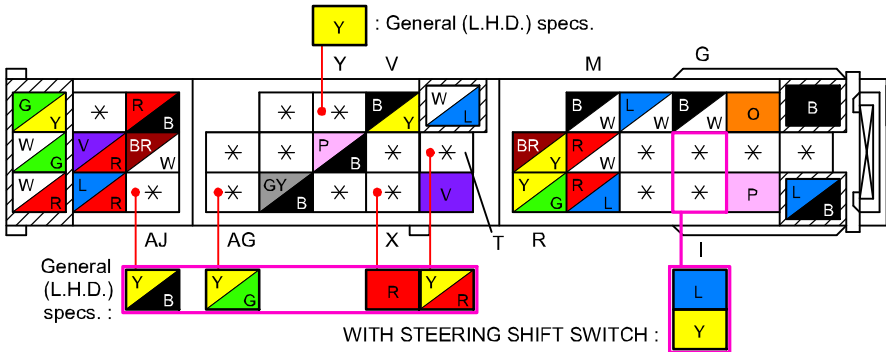

INSTRUMENT PANEL HARNESS

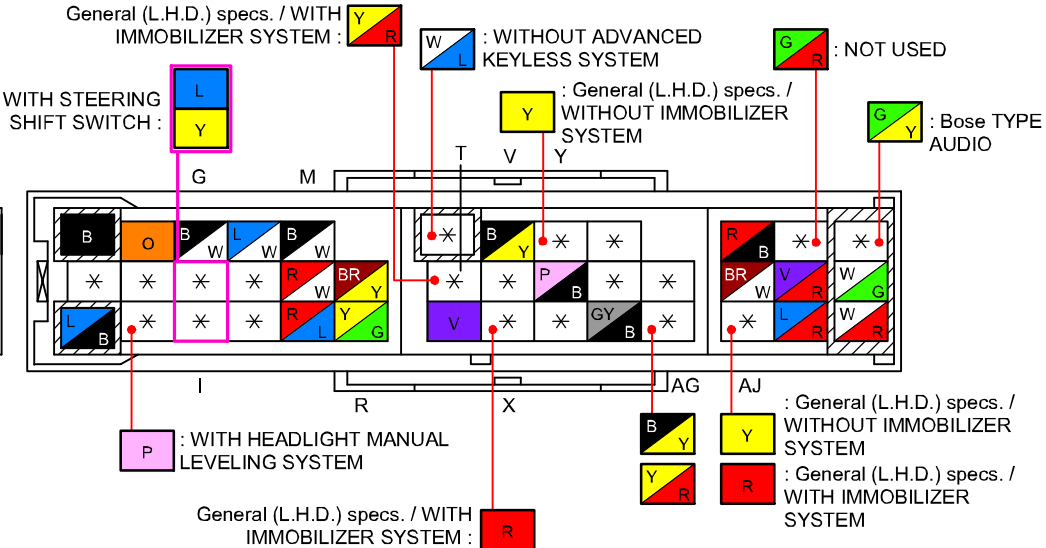

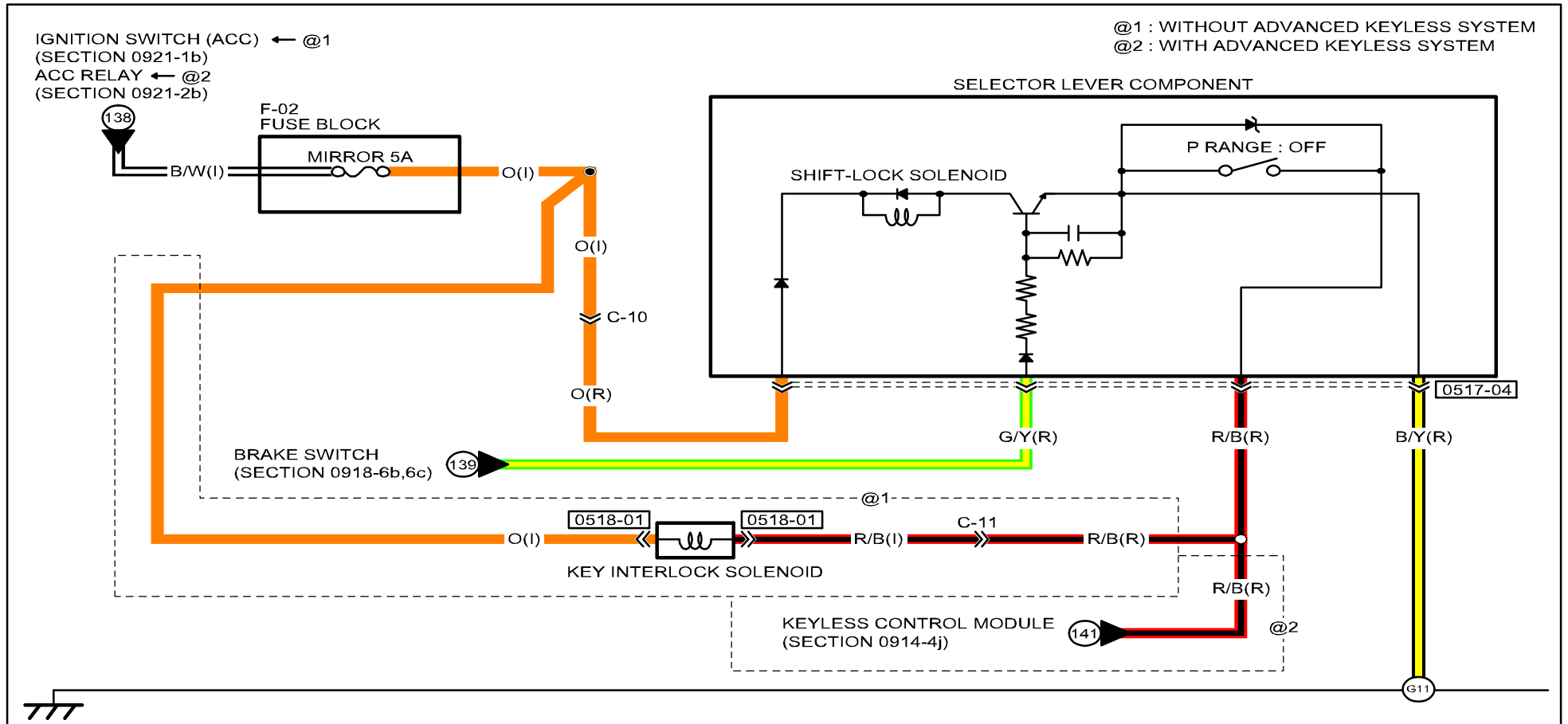

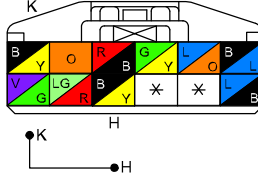
<p>0518-01 KEY INTERLOCK SOLENOID</p> 	<p>0517-04 SELECTOR LEVER COMPONENT / SELECTOR ILLUMINATION</p> 			

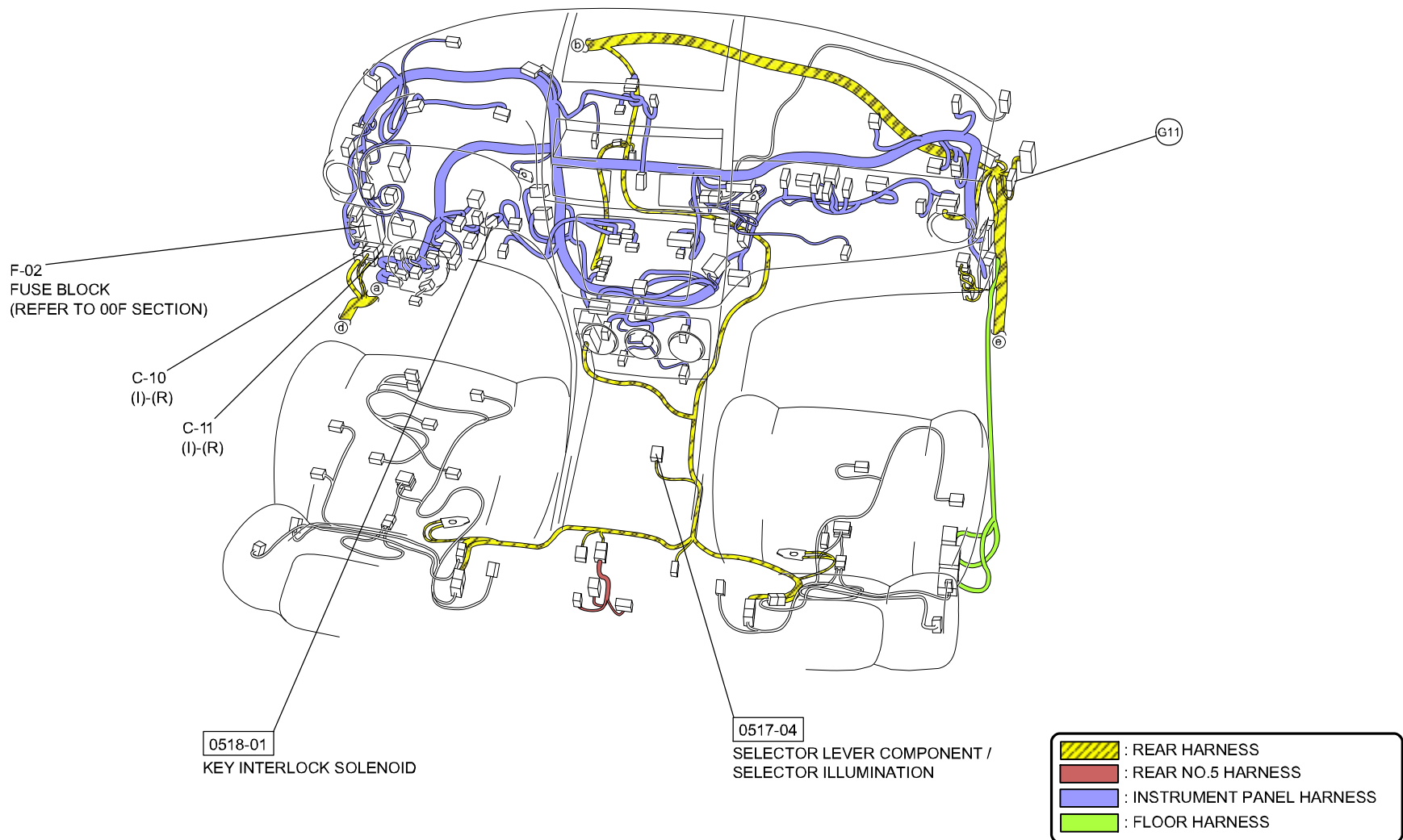

C-10
INSTRUMENT PANEL HARNESS-REAR HARNESS

INSTRUMENT PANEL HARNESS

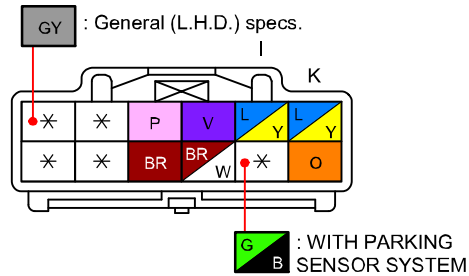

REAR HARNESS

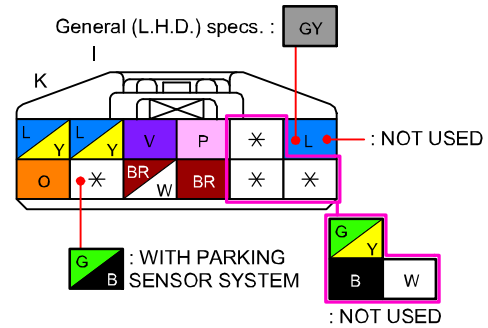

C-11
INSTRUMENT PANEL HARNESS-REAR HARNESS

INSTRUMENT PANEL HARNESS

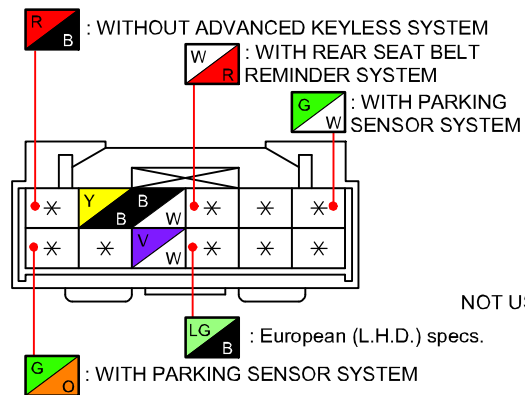

REAR HARNESS

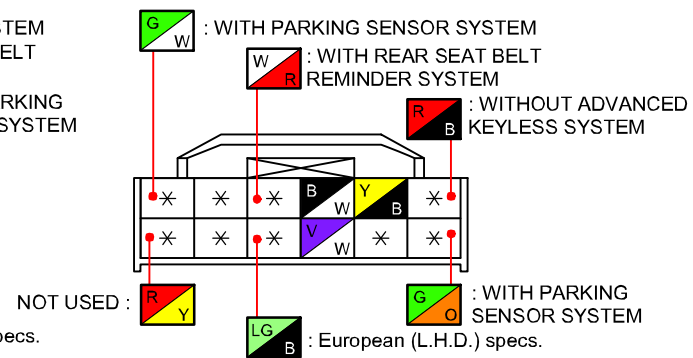

ELECTRIC POWER STEERING (EPS)

0613-a

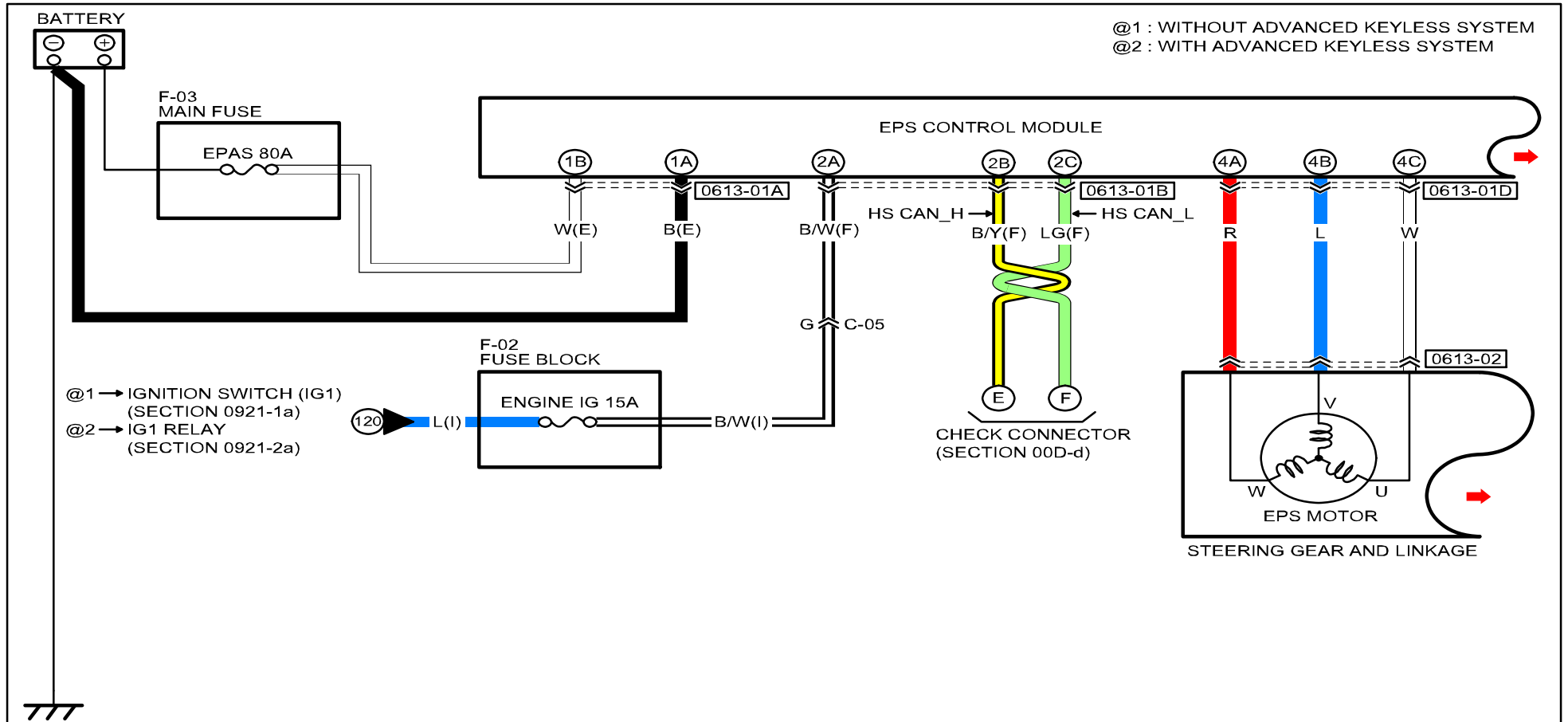

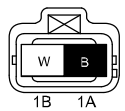
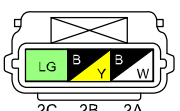
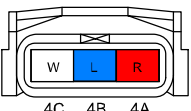
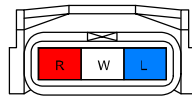
<p>0613-01A EPS CONTROL MODULE</p> 	<p>0613-01B EPS CONTROL MODULE</p> 	<p>0613-01D EPS CONTROL MODULE</p> 	<p>0613-02 EPS MOTOR</p> 			

ELECTRIC POWER STEERING (EPS)

0613-a

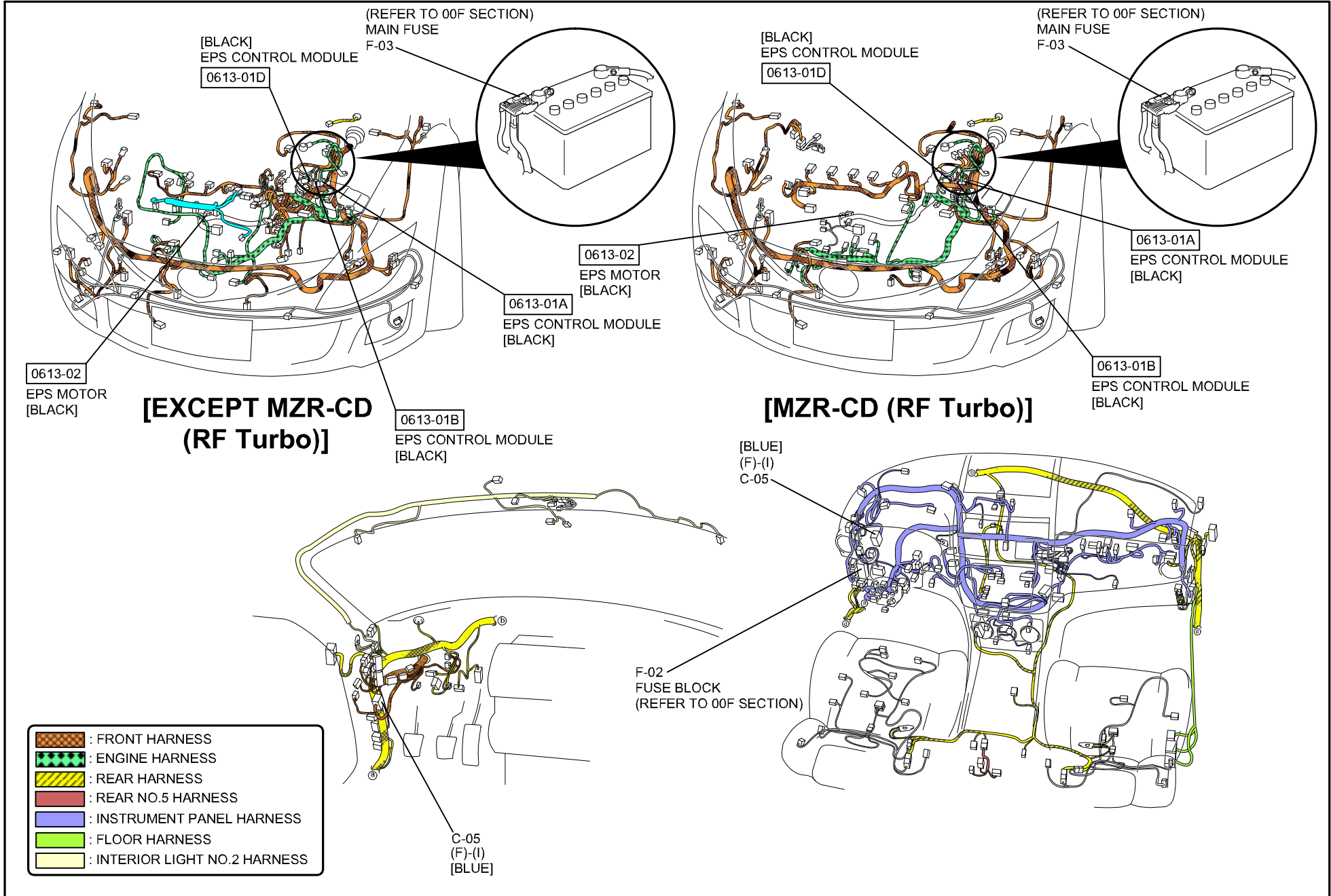

ELECTRIC POWER STEERING (EPS)

0613-a

C-05

FRONT HARNESS-INSTRUMENT PANEL HARNESS

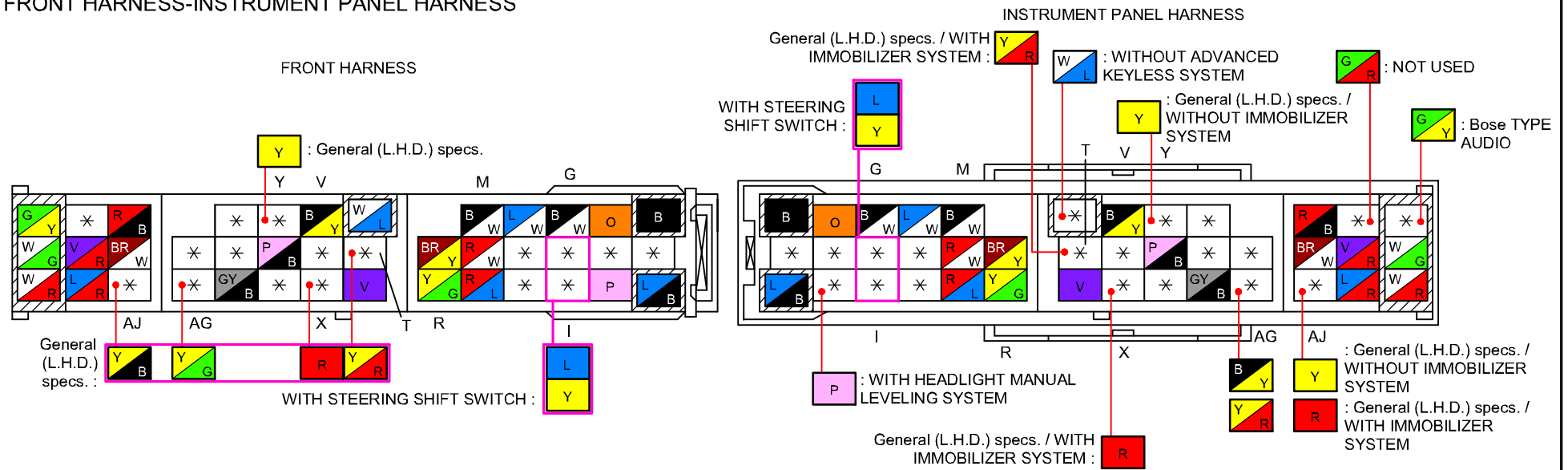

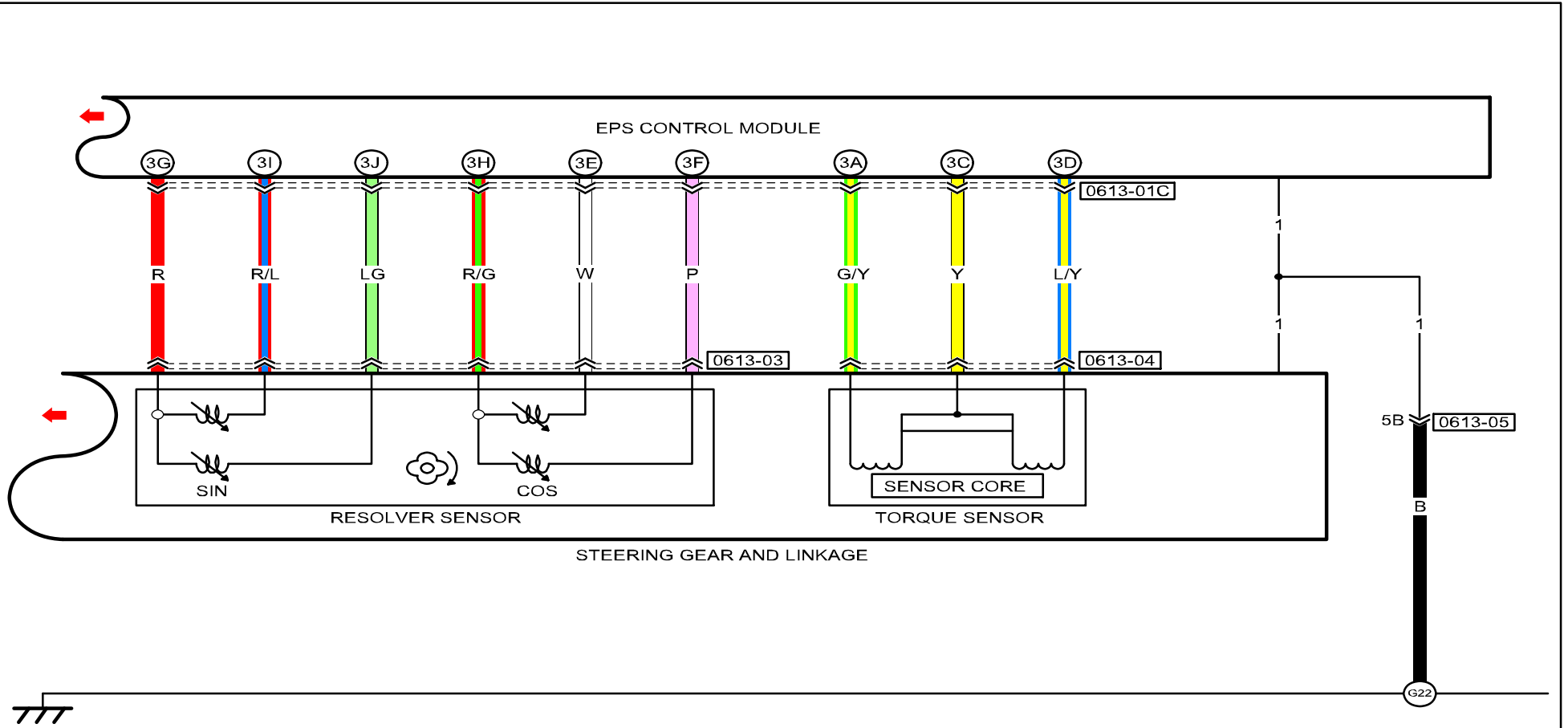

0613-01C
EPS CONTROL MODULE

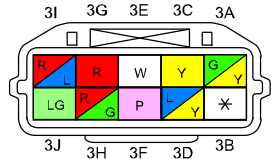

0613-03
RESOLVER SENSOR

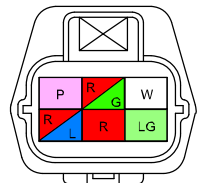

0613-04
TORQUE SENSOR

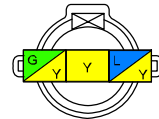

0613-05
STEERING GEAR AND LINKAGE EARTH

SHORT CORD

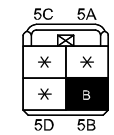

SHORT CORD

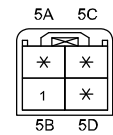

TERMINALS OF THIS CONNECTOR ARE INDICATED BY NUMBERS.

ELECTRIC POWER STEERING (EPS)

0613-b

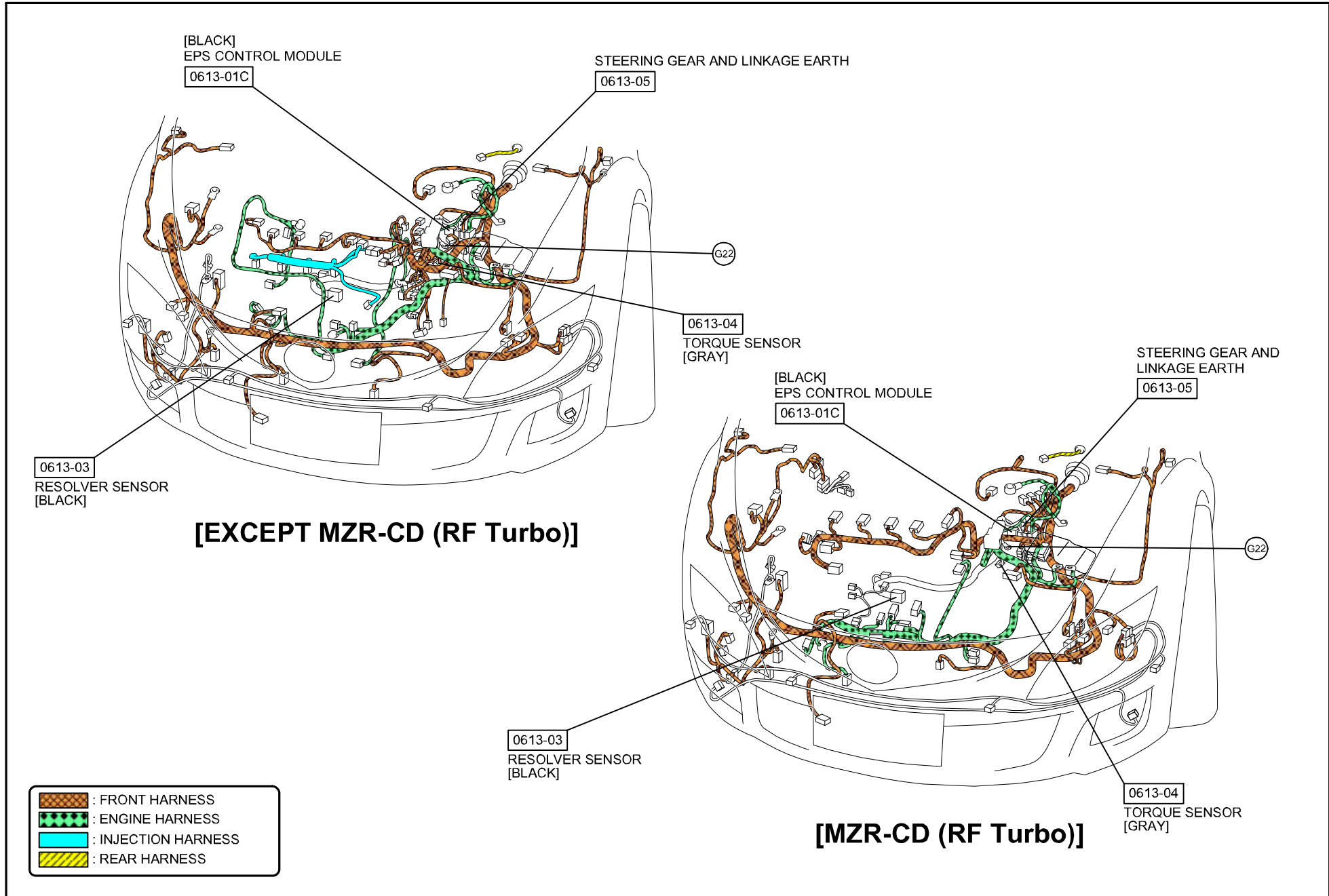

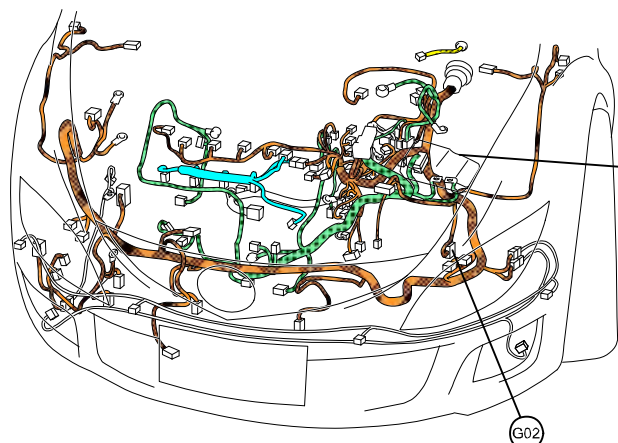

F-01
MAIN FUSE BLOCK
(REFER TO 00F SECTION)

G02

[EXCEPT MZR-CD (RF Turbo)]

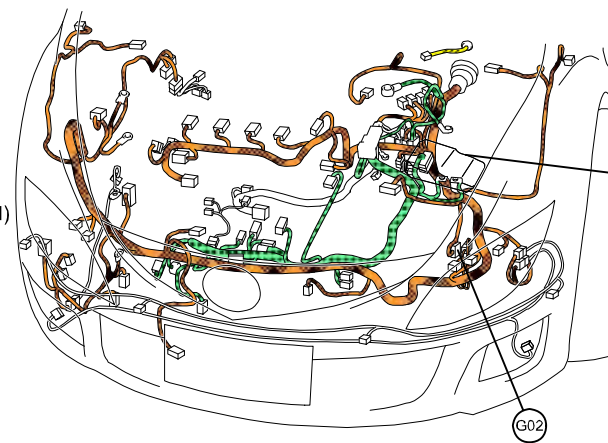

F-01
MAIN FUSE BLOCK
(REFER TO 00F SECTION)

G02

[MZR-CD (RF Turbo)]

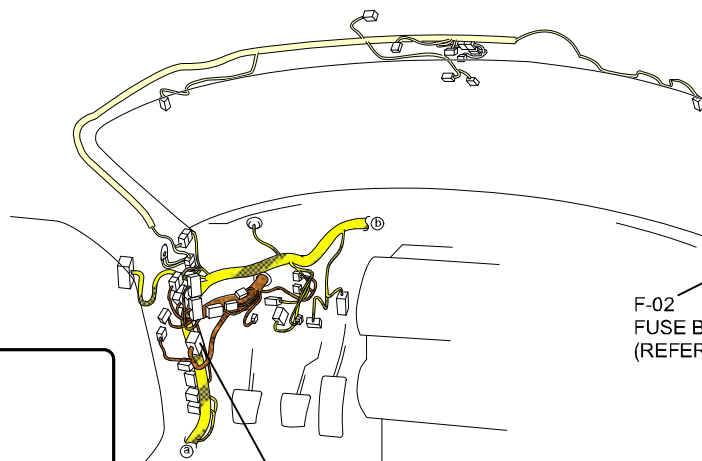

C-05
(F-I)
[BLUE]







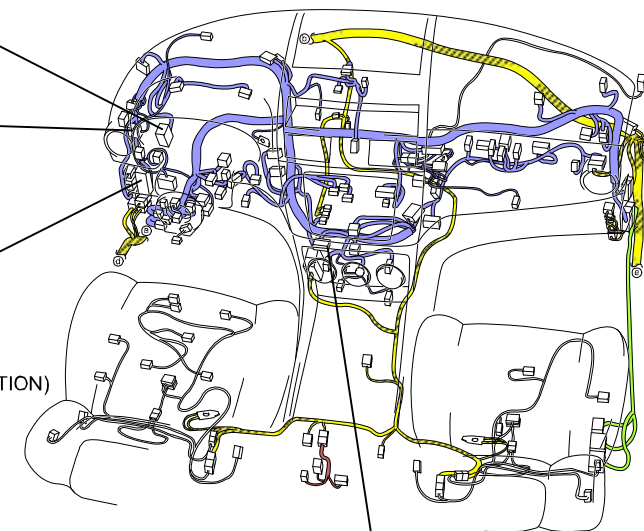

[BLUE]
(F-I)
C-05

G07

F-02
FUSE BLOCK
(REFER TO 00F SECTION)



0740-101A
CLIMATE CONTROL UNIT

-  : FRONT HARNESS
-  : ENGINE HARNESS
-  : INJECTION HARNESS
-  : REAR HARNESS
-  : REAR NO.5 HARNESS
-  : INSTRUMENT PANEL HARNESS
-  : FLOOR HARNESS
-  : INTERIOR LIGHT NO.2 HARNESS

C-05

FRONT HARNESS-INSTRUMENT PANEL HARNESS

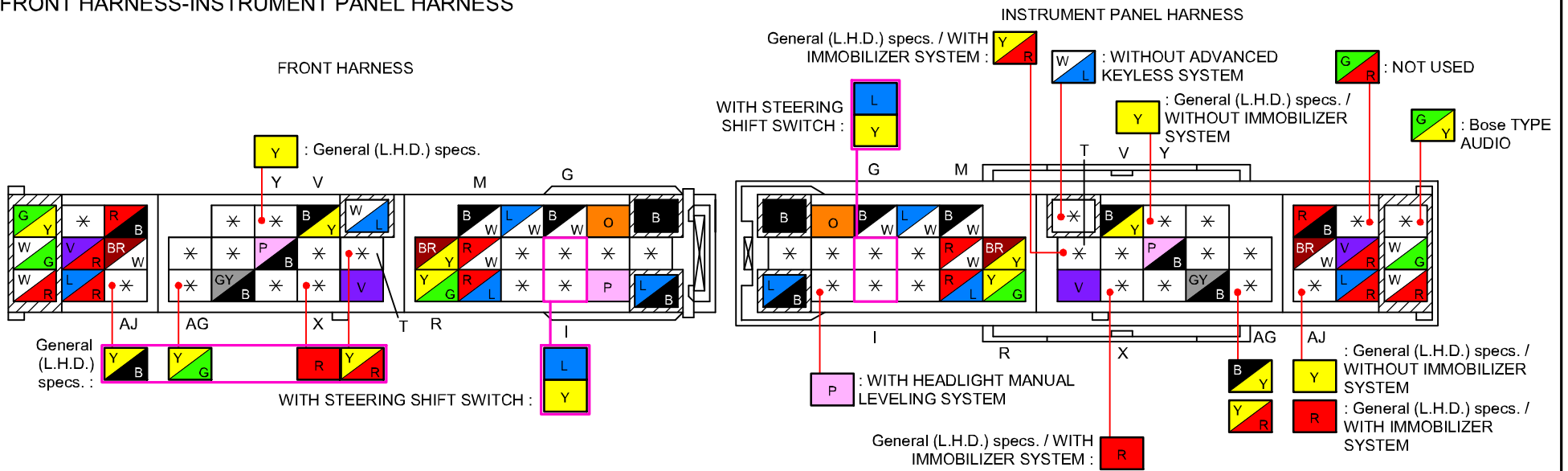

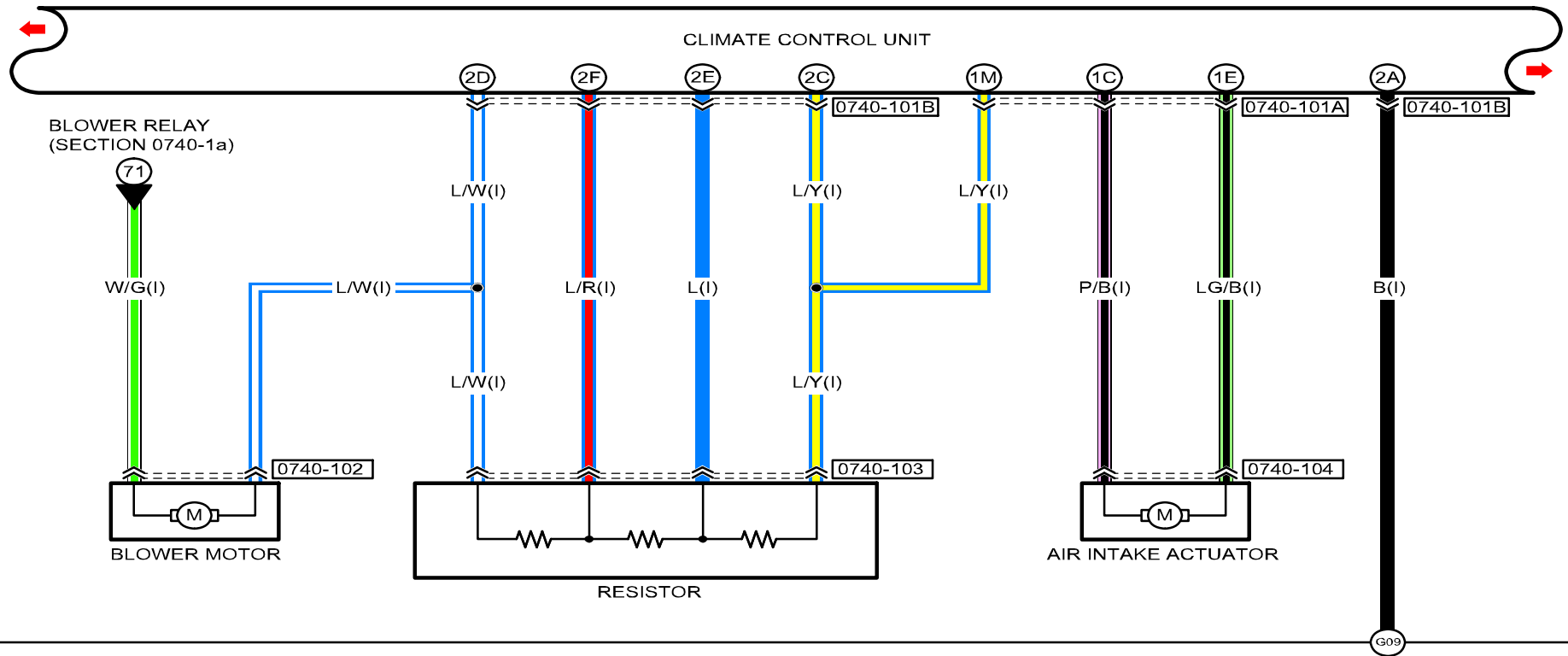

0740-101A
CLIMATE CONTROL UNIT

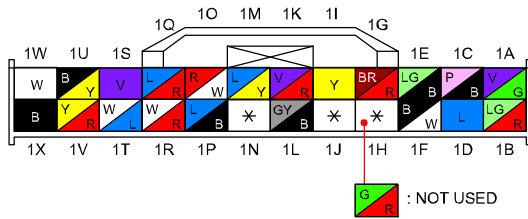

0740-101B
CLIMATE CONTROL UNIT

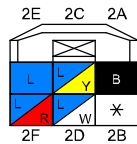

0740-102
BLOWER MOTOR





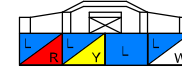

0740-103
RESISTOR

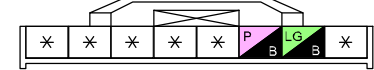

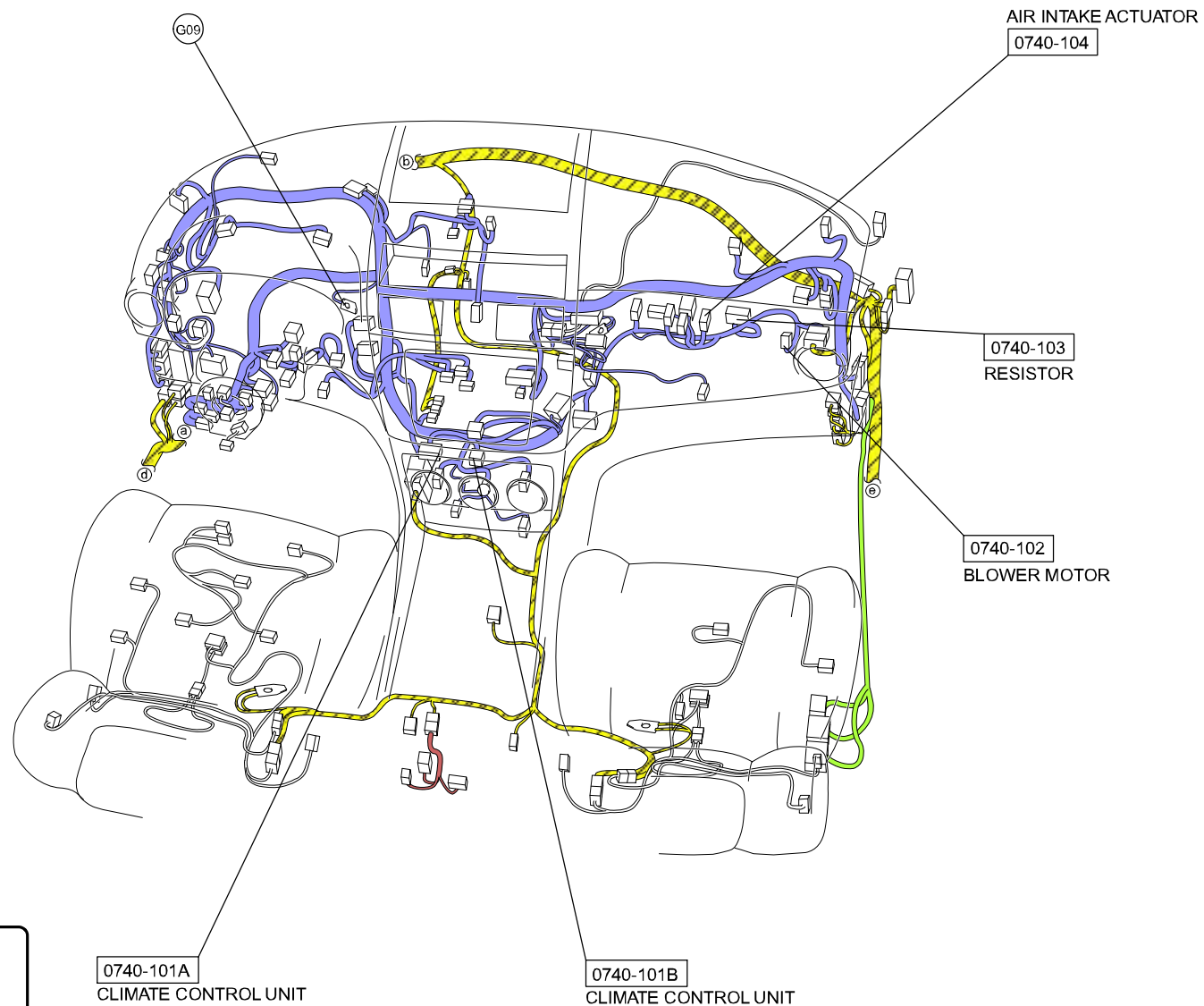
0740-104
AIR INTAKE ACTUATOR





-  : REAR HARNESS
-  : REAR NO.5 HARNESS
-  : INSTRUMENT PANEL HARNESS
-  : FLOOR HARNESS

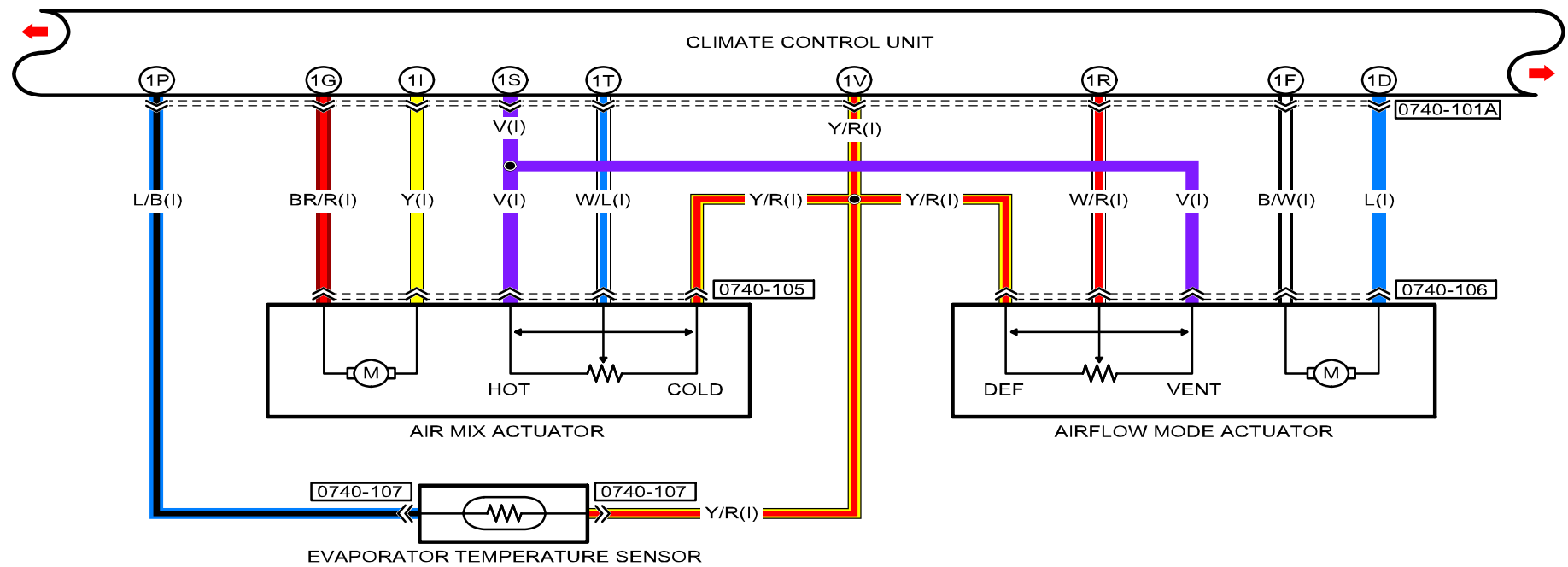

0740-101A
CLIMATE CONTROL UNIT

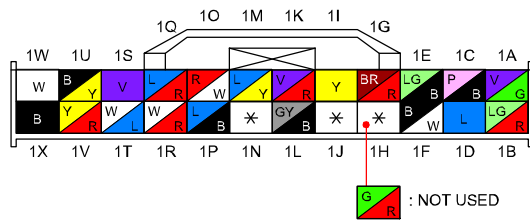

0740-105
AIR MIX ACTUATOR

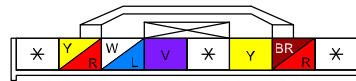



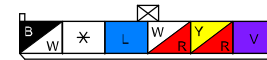

0740-106
AIRFLOW MODE ACTUATOR

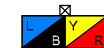

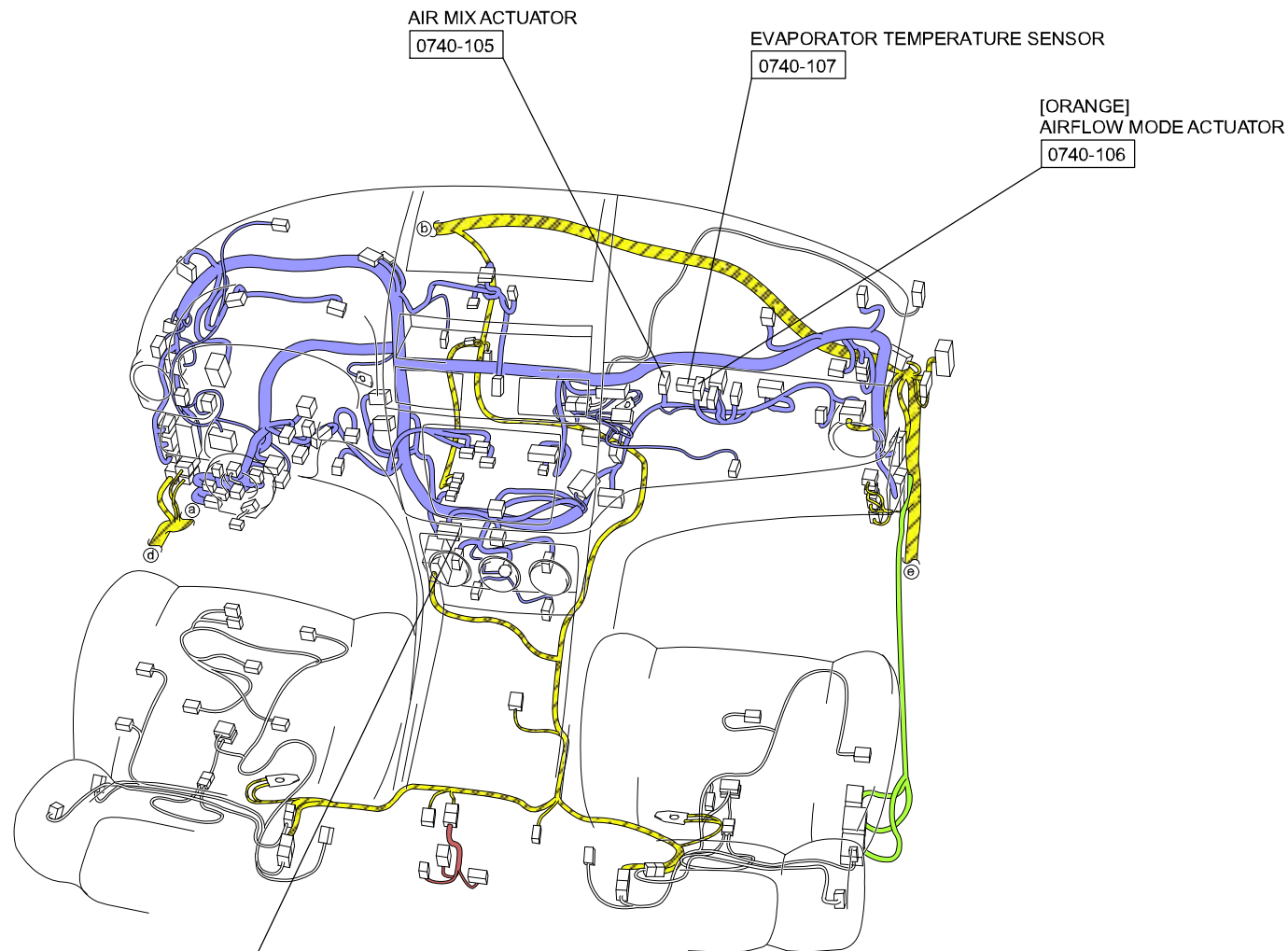
0740-107
EVAPORATOR TEMPERATURE SENSOR





-  : REAR HARNESS
-  : REAR NO.5 HARNESS
-  : INSTRUMENT PANEL HARNESS
-  : FLOOR HARNESS

0740-101A
CLIMATE CONTROL UNIT

#4 : European (L.H.D.) specs.
&4 : General (L.H.D.) specs.

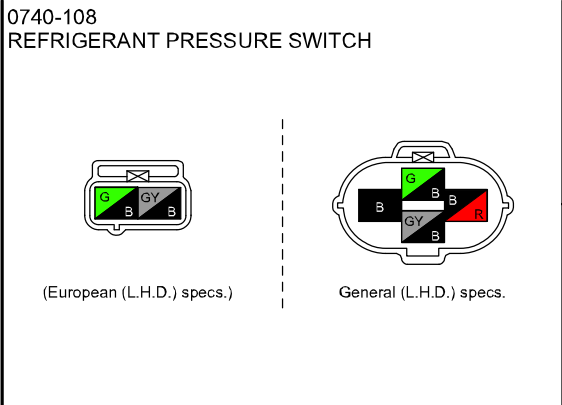
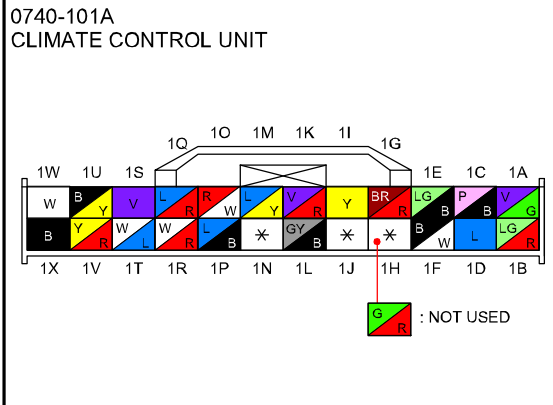
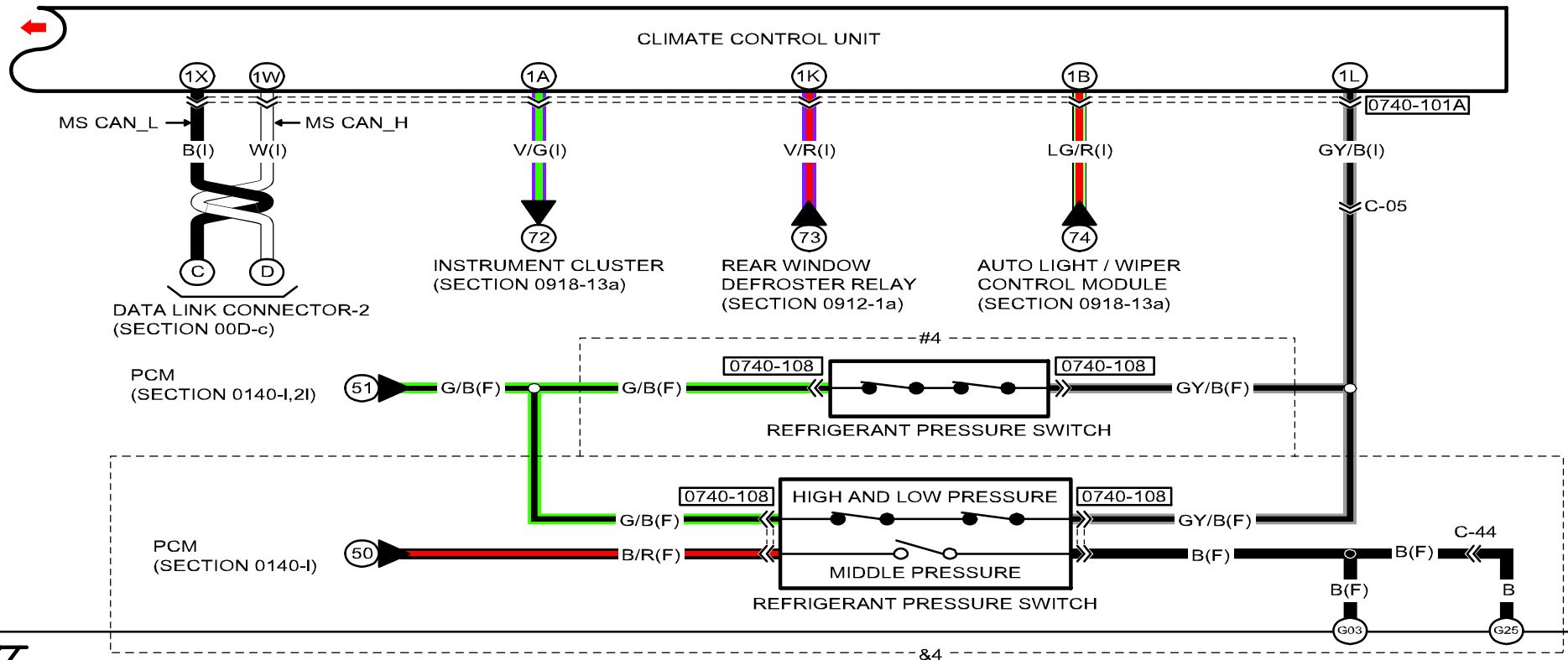

[BLACK]
REFRIGERANT PRESSURE SWITCH

0740-108

G25

G03

C-44
(F)-SHORT CORD
[GRAY]

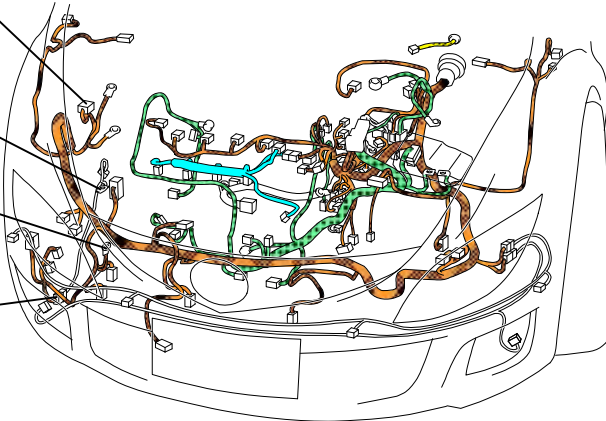

[EXCEPT MZR-CD (RF Turbo)]

[BLACK]
REFRIGERANT PRESSURE SWITCH

0740-108

G25

G03

C-44
(F)-SHORT CORD
[GRAY]

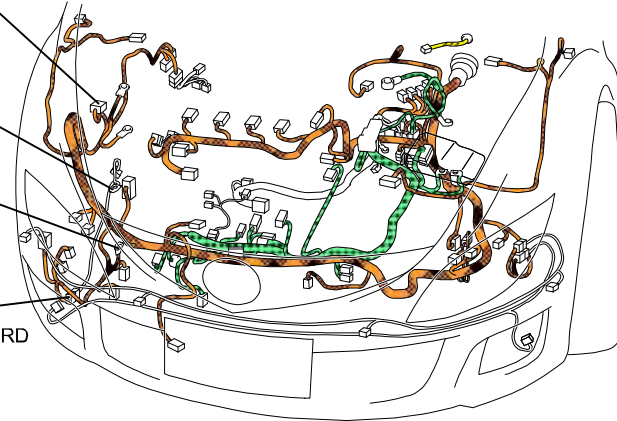

[MZR-CD (RF Turbo)]

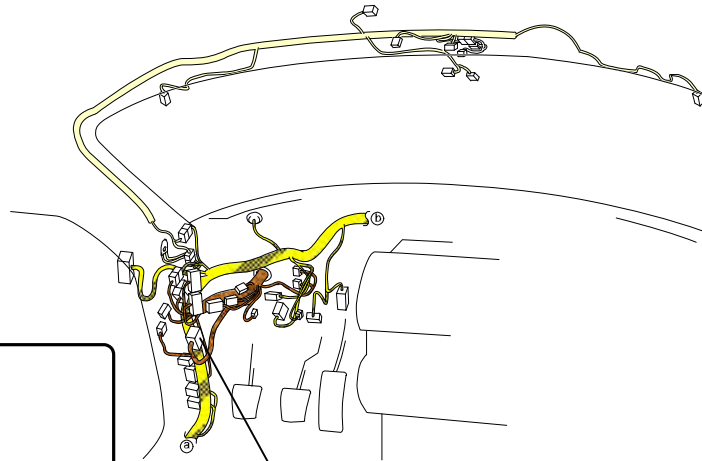

C-05
(F)-(I)
[BLUE]

- : FRONT HARNESS
- : ENGINE HARNESS
- : INJECTION HARNESS
- : REAR HARNESS
- : REAR NO.5 HARNESS
- : INSTRUMENT PANEL HARNESS
- : FLOOR HARNESS
- : INTERIOR LIGHT NO.2 HARNESS

[BLUE]
(F)-(I)
C-05

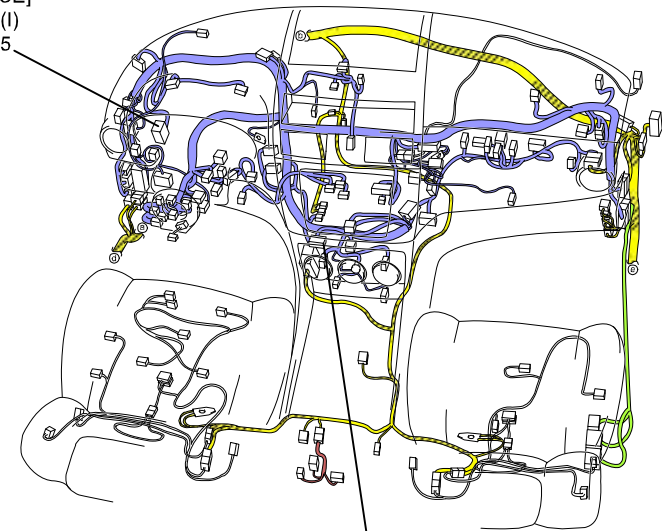

0740-101A
CLIMATE CONTROL UNIT

C-05

FRONT HARNESS-INSTRUMENT PANEL HARNESS

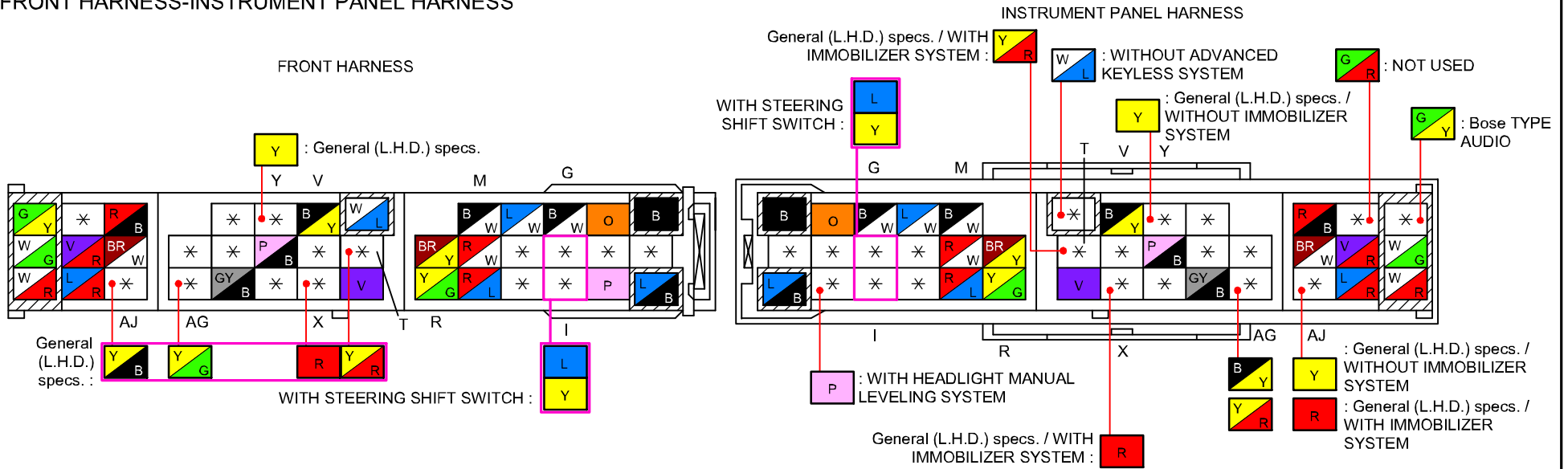

C-44

FRONT HARNESS-SHORT CORD

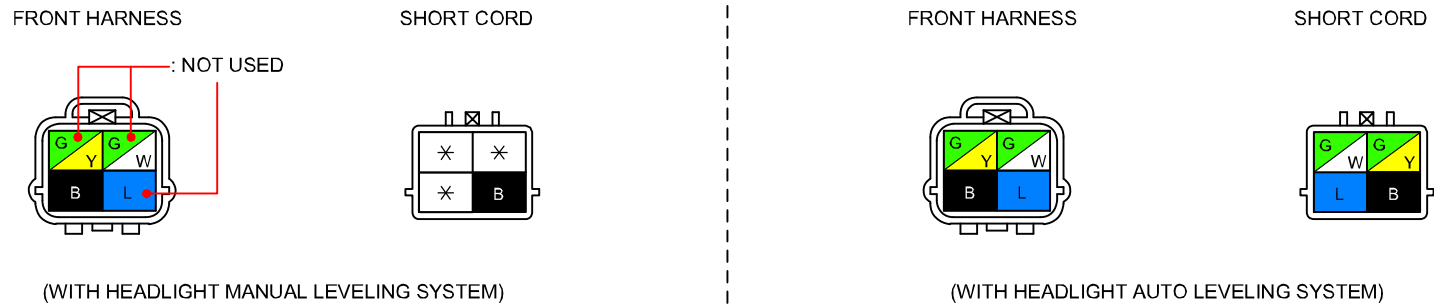

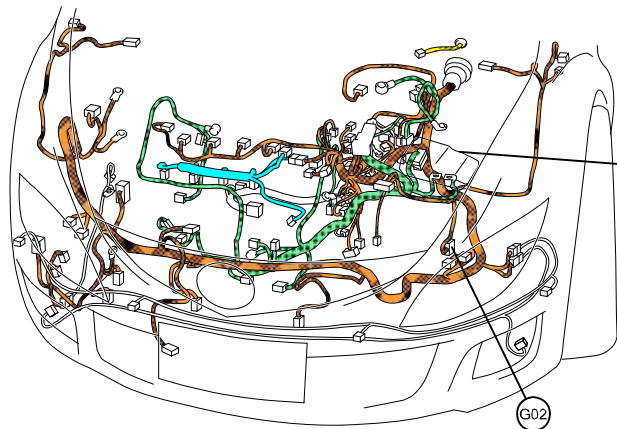

F-01
MAIN FUSE BLOCK
(REFER TO 00F SECTION)

G02

[EXCEPT MZR-CD (RF Turbo)]

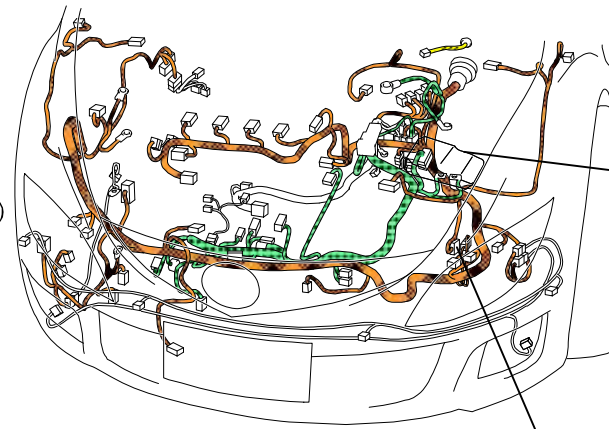

F-01
MAIN FUSE BLOCK
(REFER TO 00F SECTION)

G02

[MZR-CD (RF Turbo)]

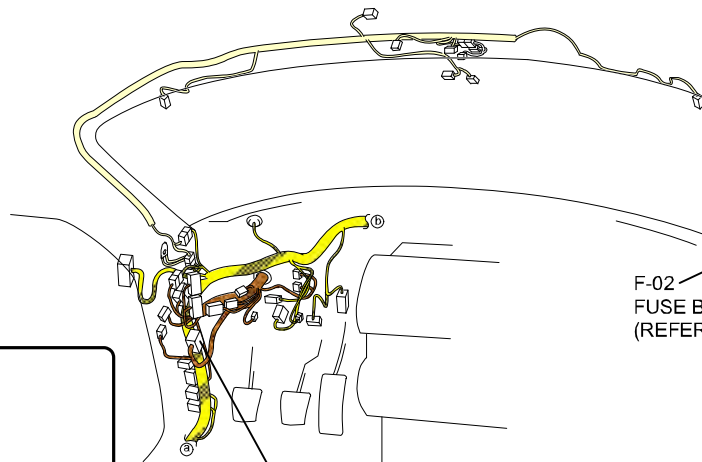

C-05
(F)-(I)
[BLUE]

[BLUE]
(F)-(I)
C-05

G07

F-02
FUSE BLOCK
(REFER TO 00F SECTION)

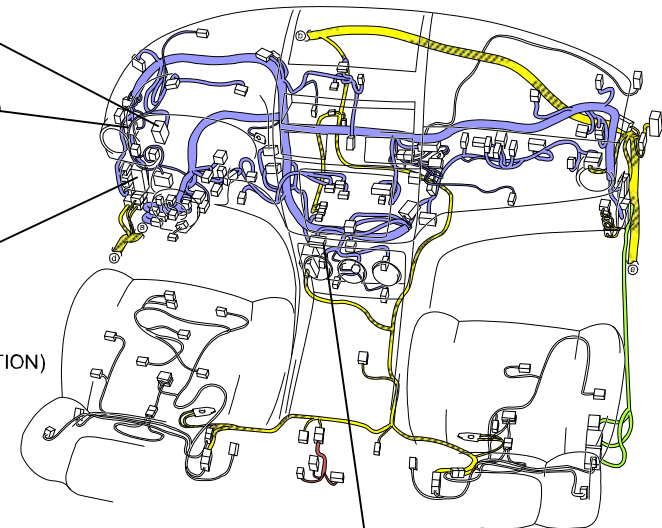

0740-201A
CLIMATE CONTROL UNIT

- : FRONT HARNESS
- : ENGINE HARNESS
- : INJECTION HARNESS
- : REAR HARNESS
- : REAR NO.5 HARNESS
- : INSTRUMENT PANEL HARNESS
- : FLOOR HARNESS
- : INTERIOR LIGHT NO.2 HARNESS

HEATER AND AIR CONDITIONER SYSTEM (AUTO A/C)

0740-2a

C-05

FRONT HARNESS-INSTRUMENT PANEL HARNESS

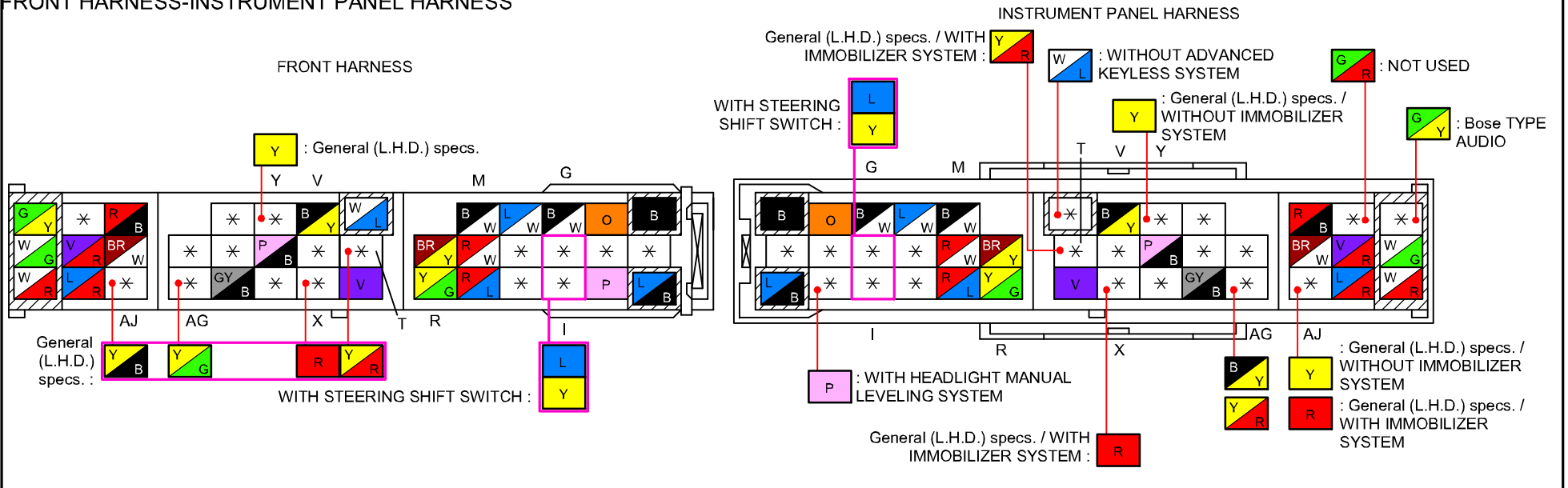

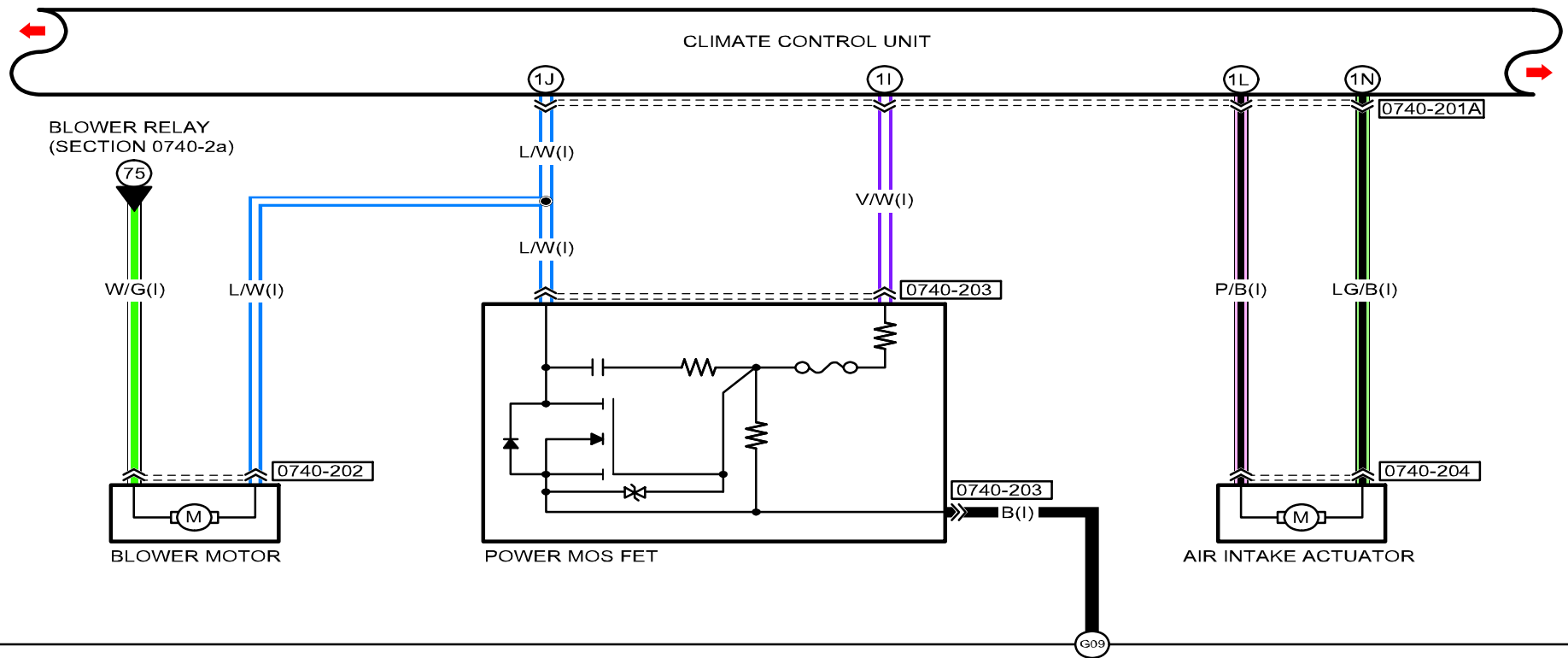

0740-201A
CLIMATE CONTROL UNIT

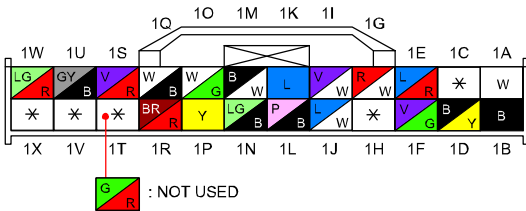

0740-202
BLOWER MOTOR





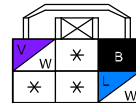

0740-203
POWER MOS FET

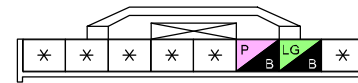

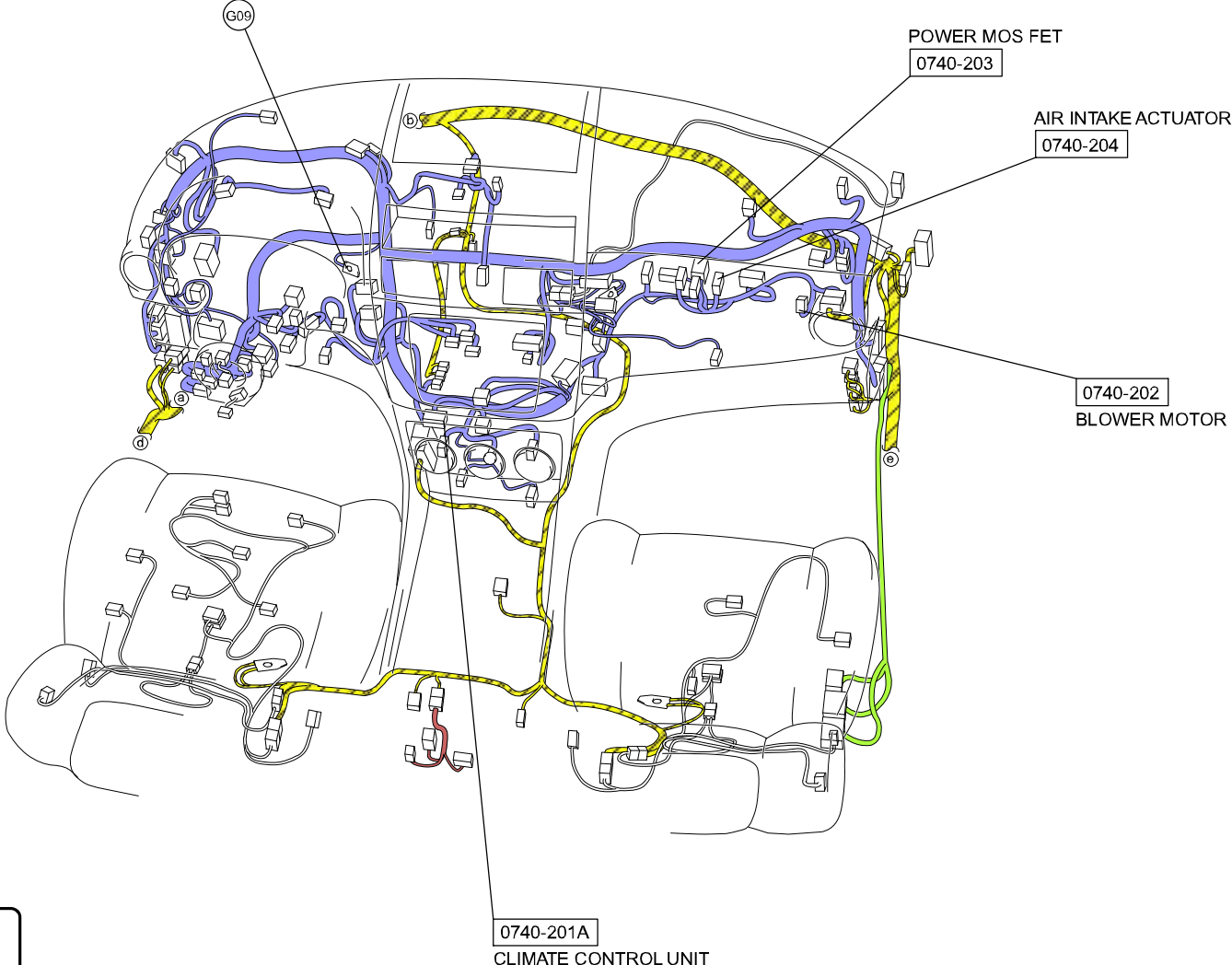
0740-204
AIR INTAKE ACTUATOR





-  : REAR HARNESS
-  : REAR NO.5 HARNESS
-  : INSTRUMENT PANEL HARNESS
-  : FLOOR HARNESS

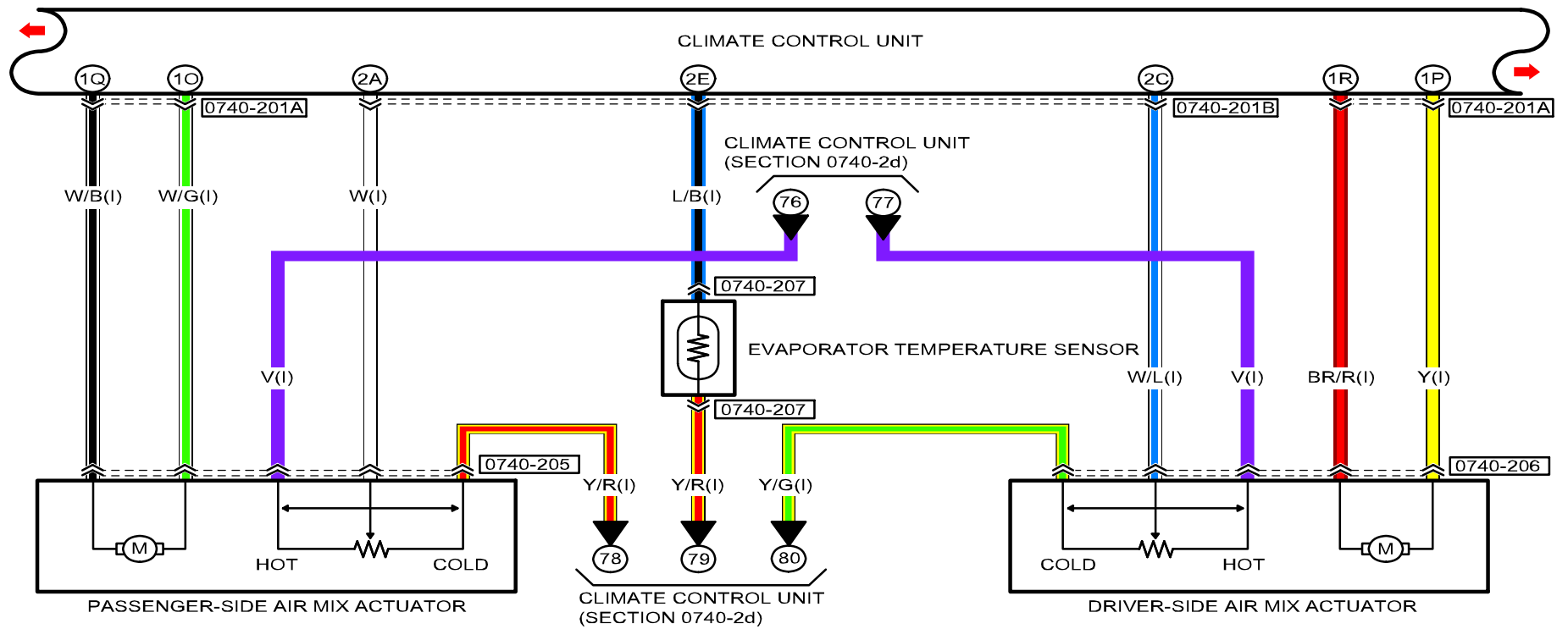

0740-201A
CLIMATE CONTROL UNIT

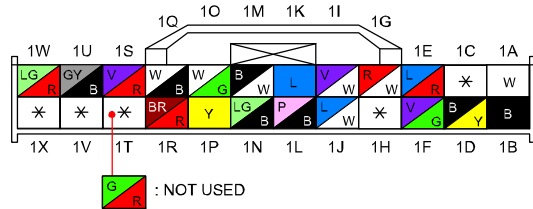

0740-201B
CLIMATE CONTROL UNIT

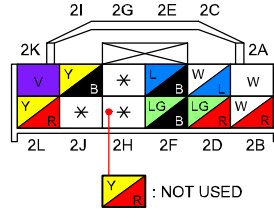

0740-205
PASSENGER-SIDE AIR MIX ACTUATOR

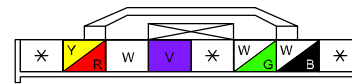

0740-206
DRIVER-SIDE AIR MIX ACTUATOR

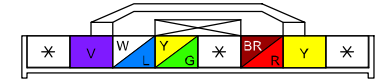

0740-207
EVAPORATOR TEMPERATURE SENSOR



HEATER AND AIR CONDITIONER SYSTEM (AUTO A/C)

0740-2c

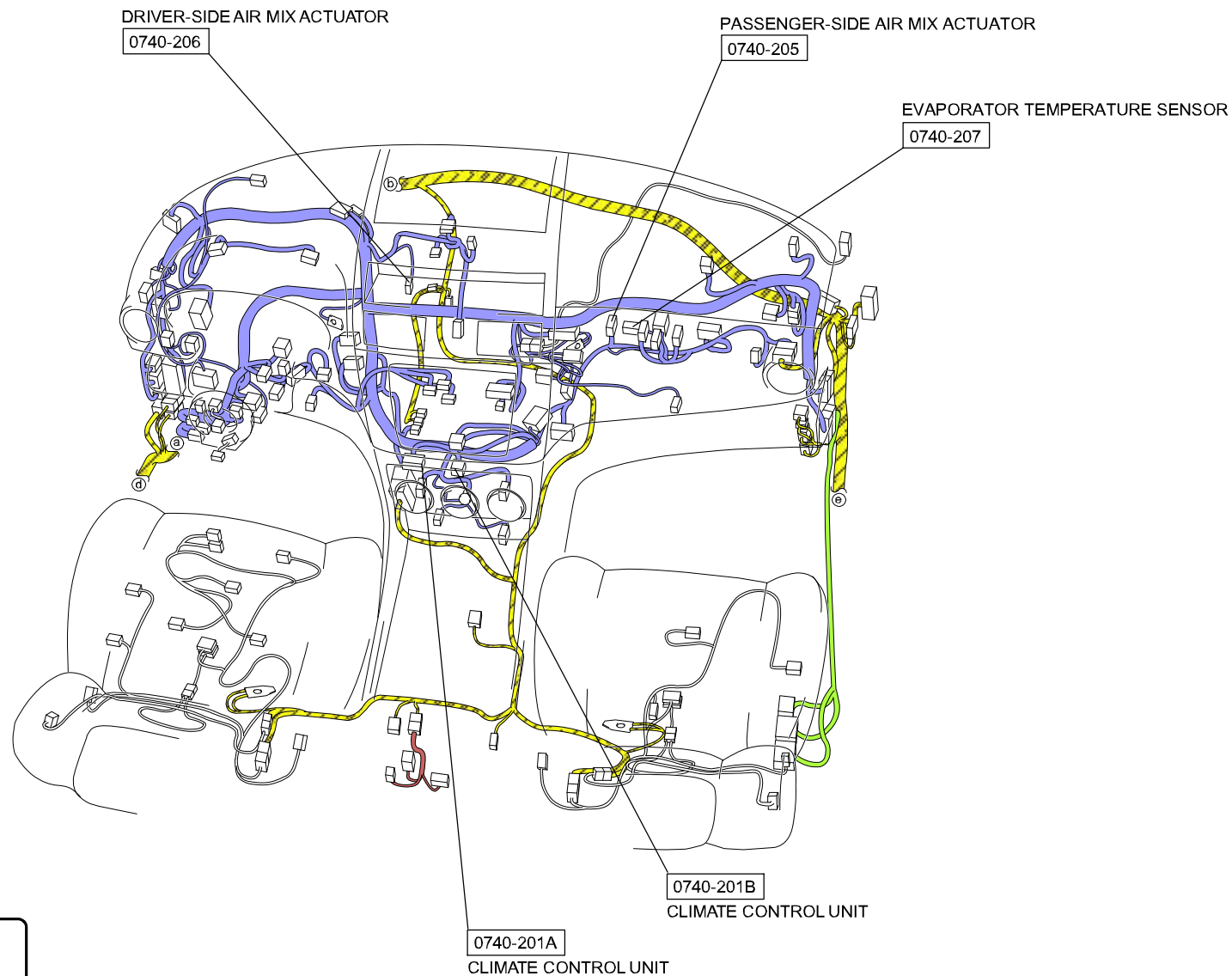

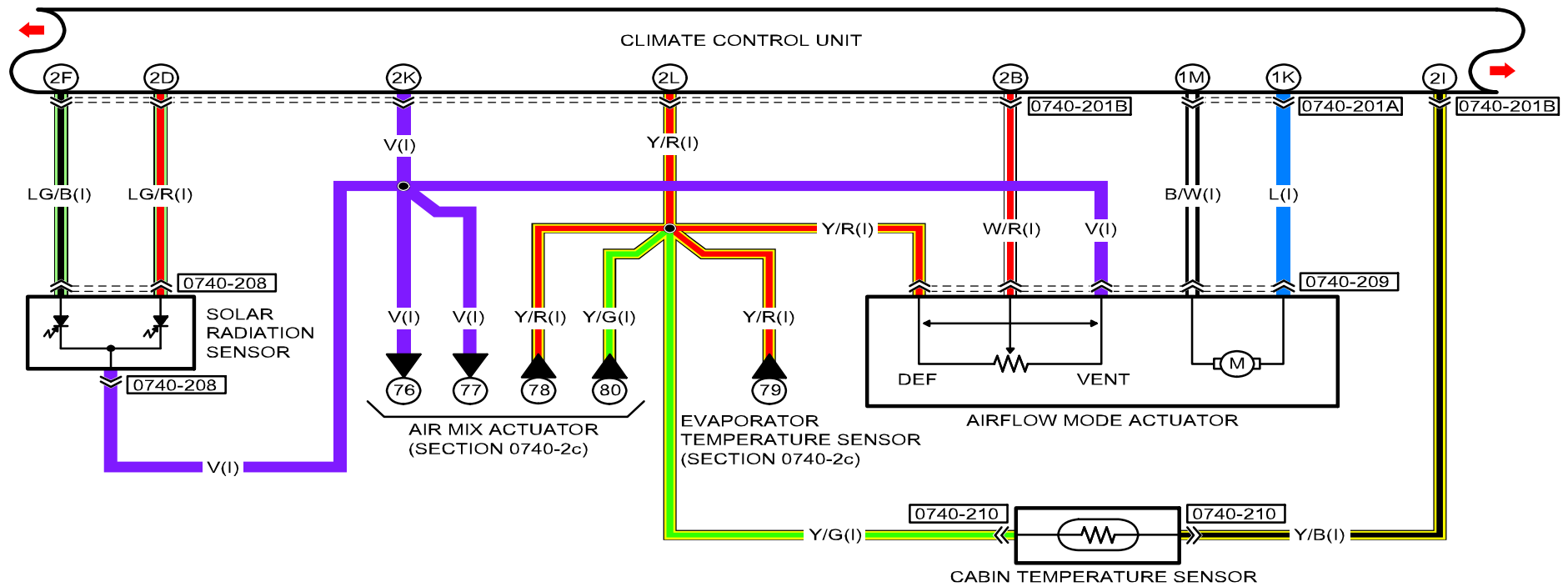

0740-201A
CLIMATE CONTROL UNIT

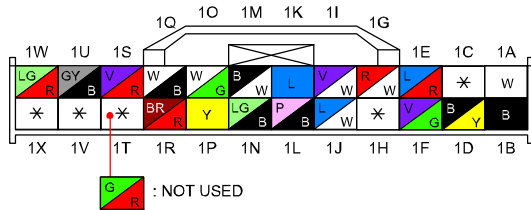

0740-201B
CLIMATE CONTROL UNIT

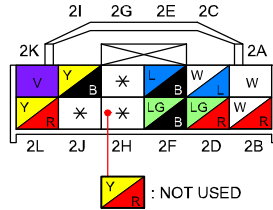

0740-208
SOLAR RADIATION SENSOR

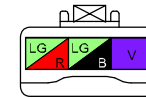

0740-209
AIRFLOW MODE ACTUATOR

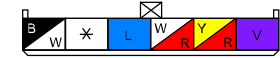

0740-210
CABIN TEMPERATURE SENSOR

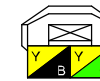

HEATER AND AIR CONDITIONER SYSTEM (AUTO A/C)

0740-2d

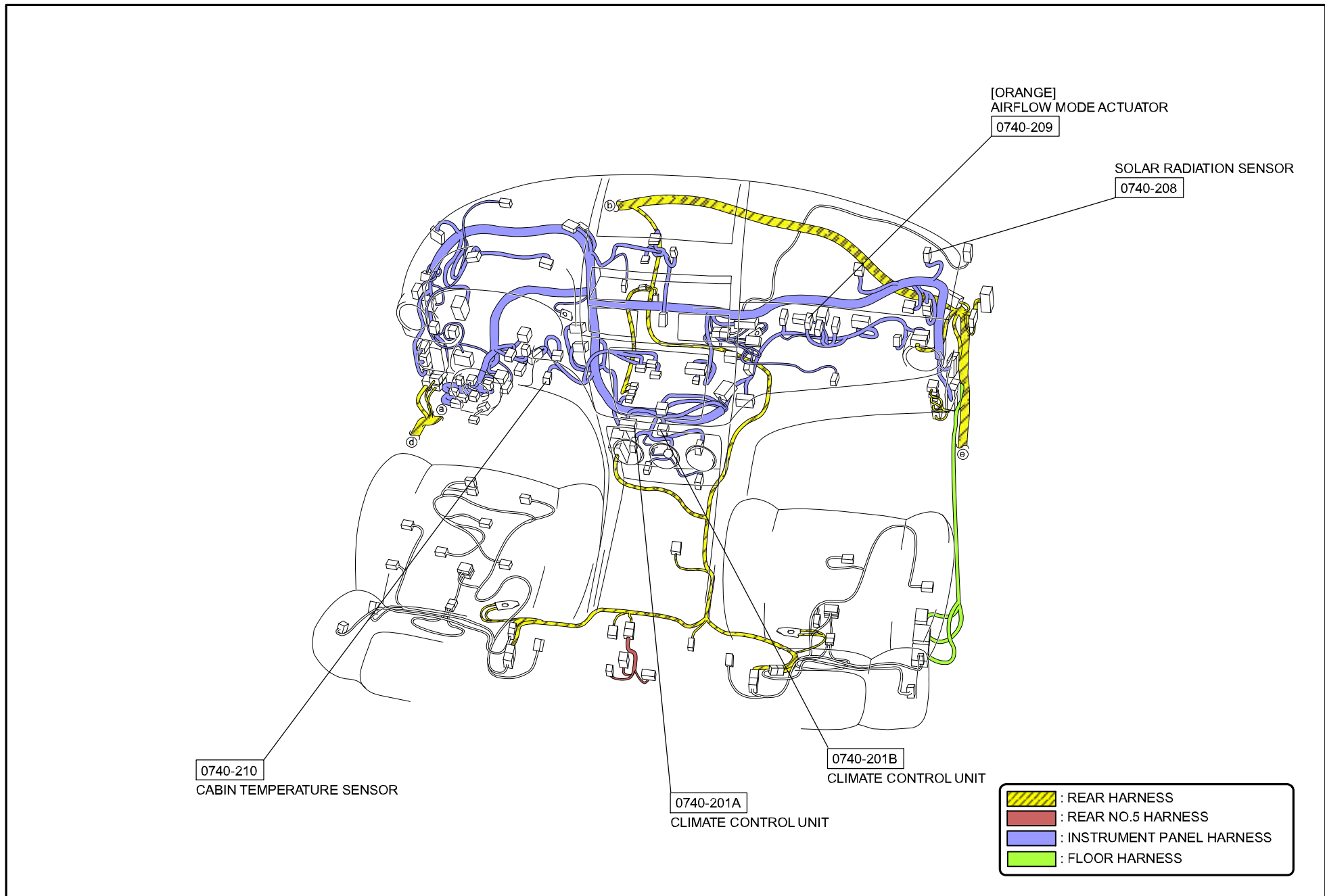

#4 : European (L.H.D.) specs.
&4 : General (L.H.D.) specs.

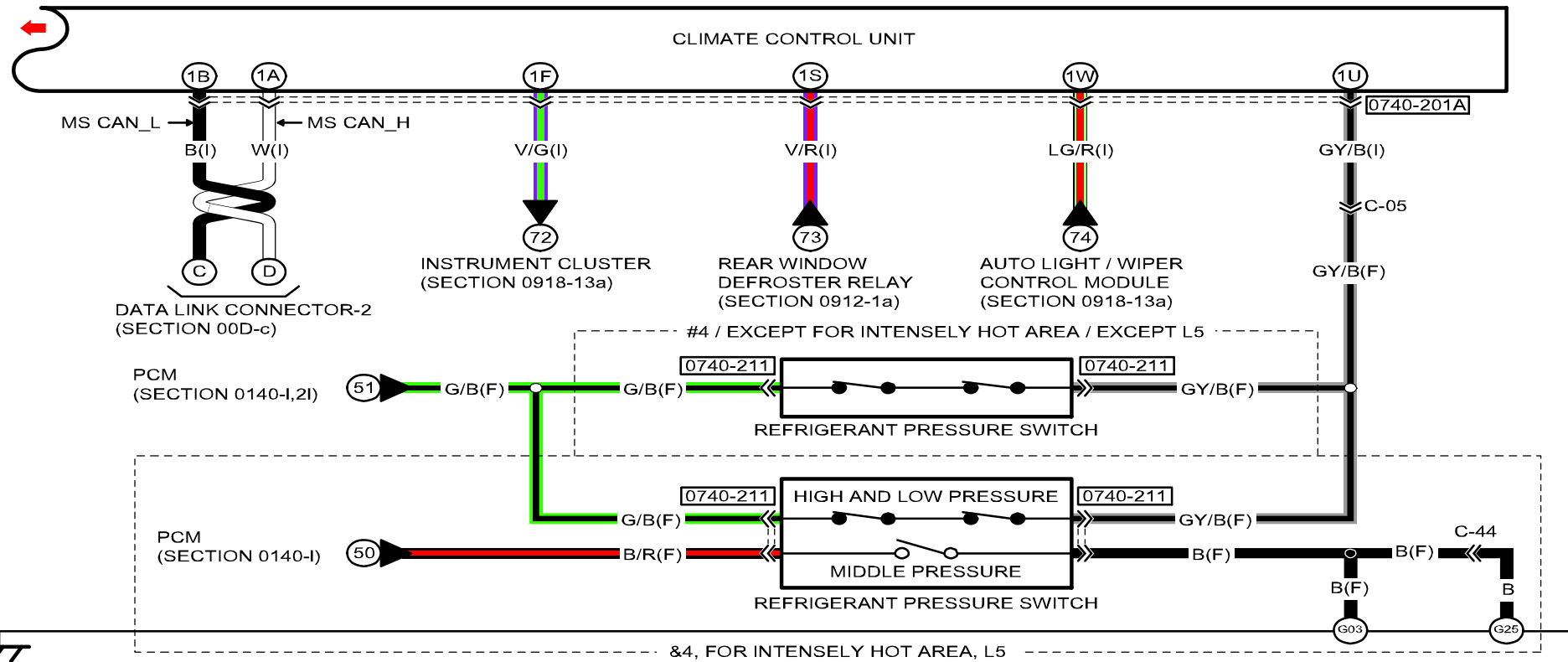

0740-201A
CLIMATE CONTROL UNIT

0740-211
REFRIGERANT PRESSURE SWITCH

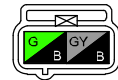
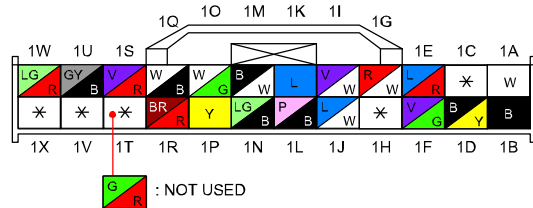

(European (L.H.D.) specs. /
EXCEPT FOR INTENSELY
HOT AREA / EXCEPT L5)

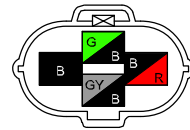

(General (L.H.D.) specs., FOR
INTENSELY HOT AREA, L5)

[BLACK]
REFRIGERANT PRESSURE SWITCH
0740-211

G25

G03

C-44
(F)-SHORT CORD
[GRAY]

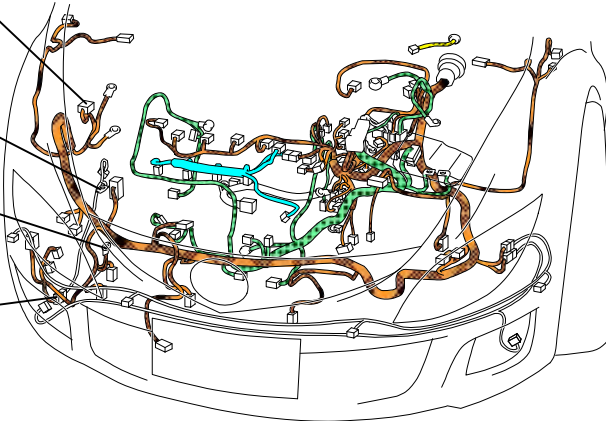

[EXCEPT MZR-CD (RF Turbo)]

[BLACK]
REFRIGERANT PRESSURE SWITCH
0740-211

G25

G03

C-44
(F)-SHORT CORD
[GRAY]

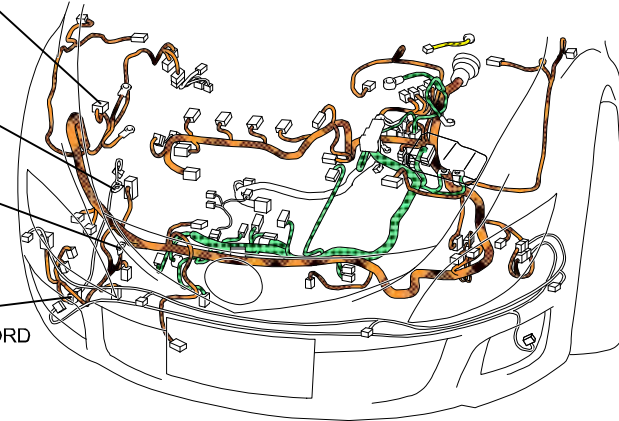

[MZR-CD (RF Turbo)]

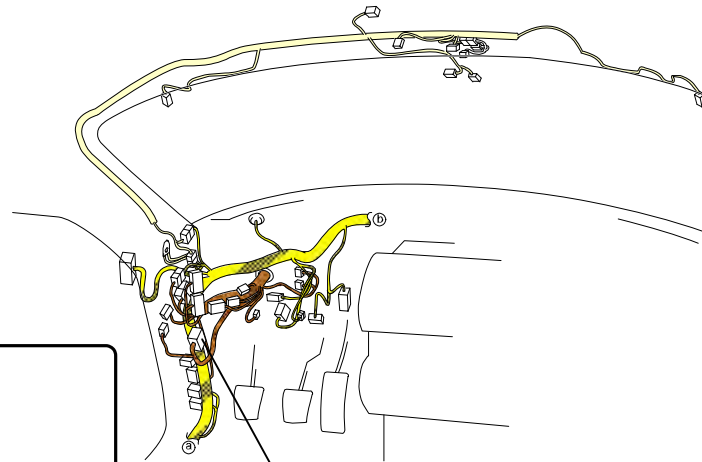

C-05
(F)-(I)
[BLUE]

- : FRONT HARNESS
- : ENGINE HARNESS
- : INJECTION HARNESS
- : REAR HARNESS
- : REAR NO.5 HARNESS
- : INSTRUMENT PANEL HARNESS
- : FLOOR HARNESS
- : INTERIOR LIGHT NO.2 HARNESS

[BLUE]
(F)-(I)
C-05

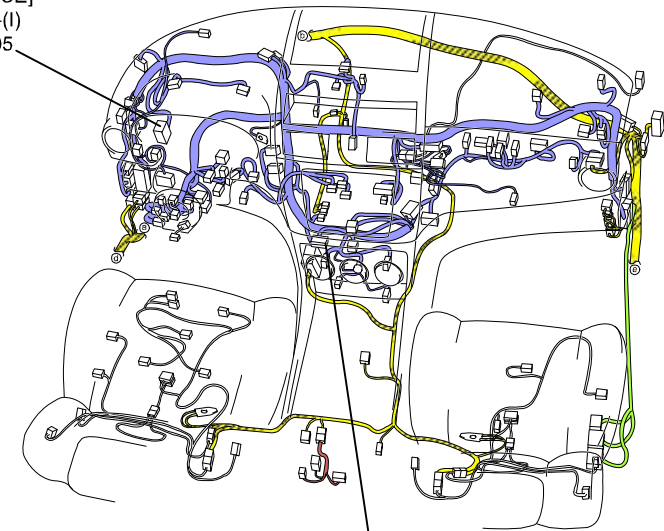

0740-201A
CLIMATE CONTROL UNIT

C-05

FRONT HARNESS-INSTRUMENT PANEL HARNESS

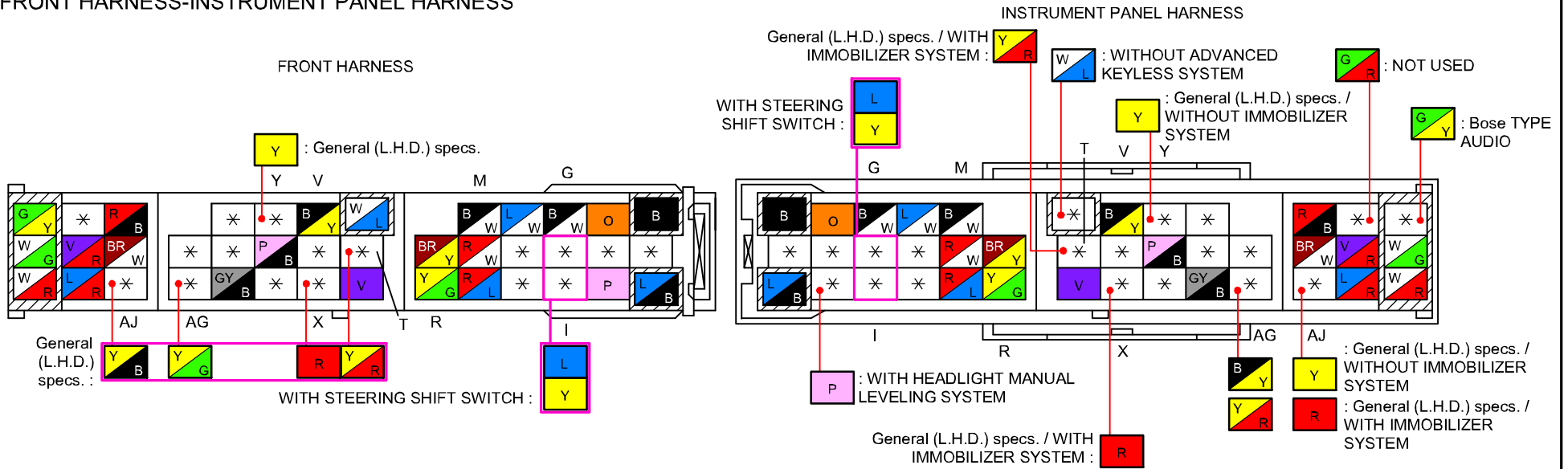

C-44

FRONT HARNESS-SHORT CORD

FRONT HARNESS

SHORT CORD

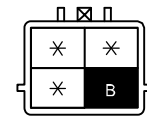
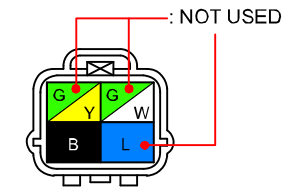

(WITH HEADLIGHT MANUAL LEVELING SYSTEM)

FRONT HARNESS

SHORT CORD

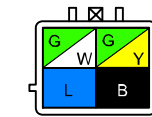
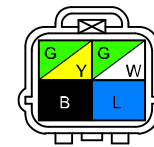

(WITH HEADLIGHT AUTO LEVELING SYSTEM)

A/C COMPRESSOR CONTROL

0740-3

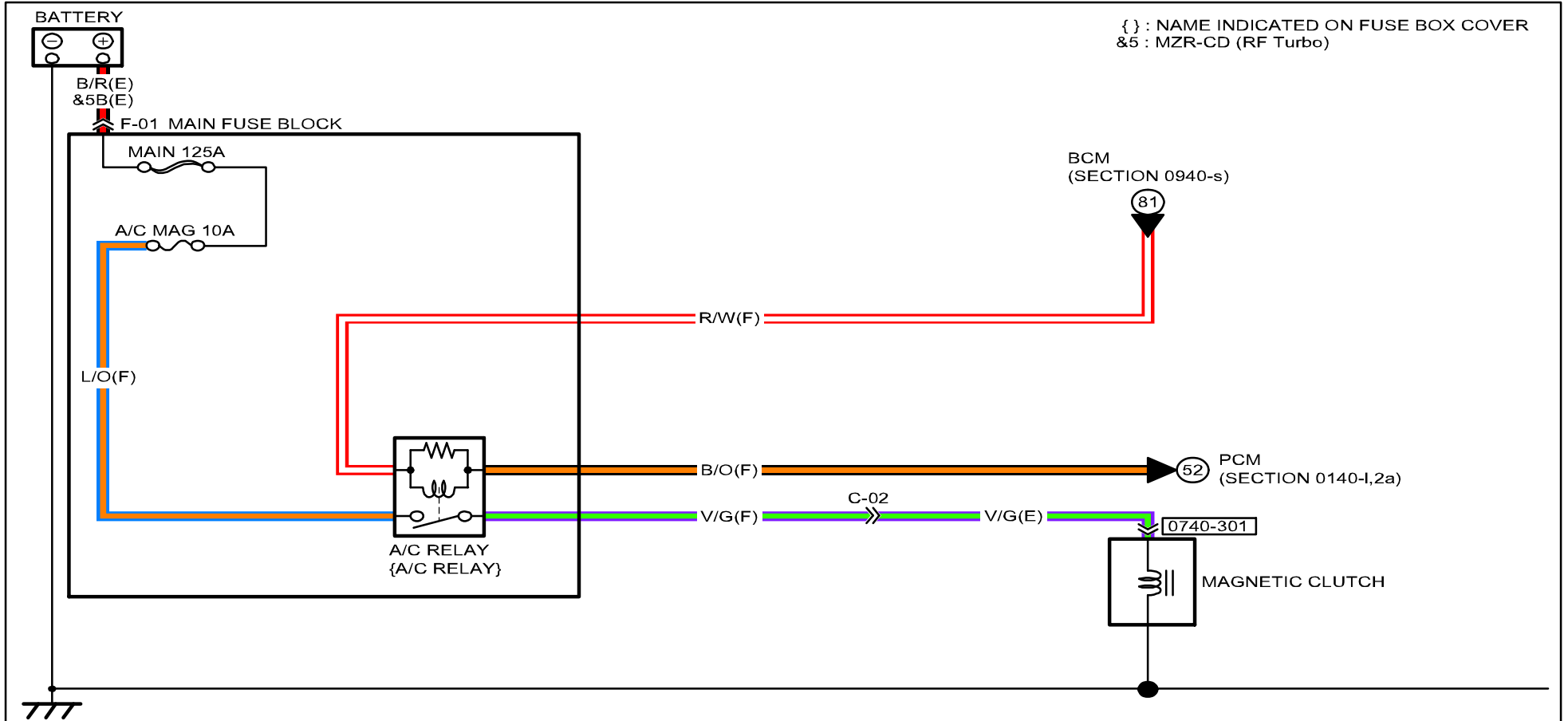

{ } : NAME INDICATED ON FUSE BOX COVER
&5 : MZR-CD (RF Turbo)

0740-301
MAGNETIC CLUTCH

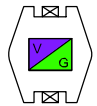

(EXCEPT MZR-CD (RF Turbo))



(MZR-CD (RF Turbo))

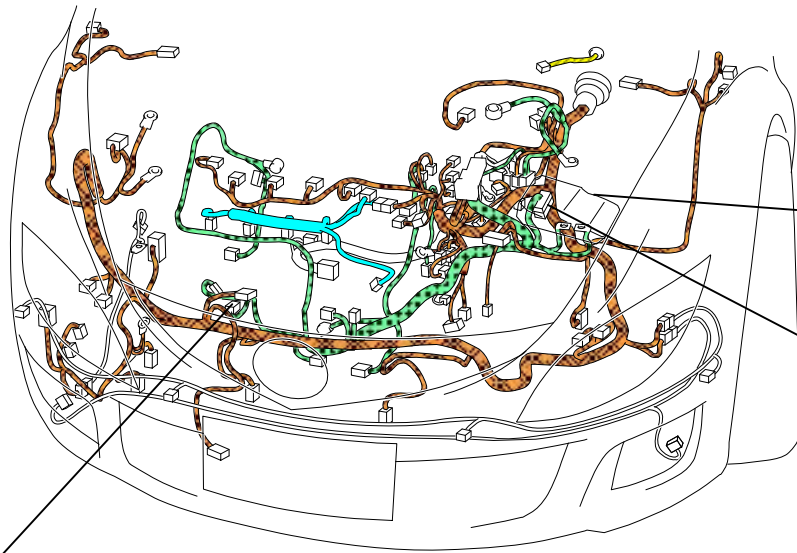

0740-301
MAGNETIC CLUTCH
[GRAY]

[EXCEPT MZR-CD (RF Turbo)]

F-01
MAIN FUSE BLOCK
(REFER TO 00F SECTION)

C-02
(F)-(E)
[GRAY]



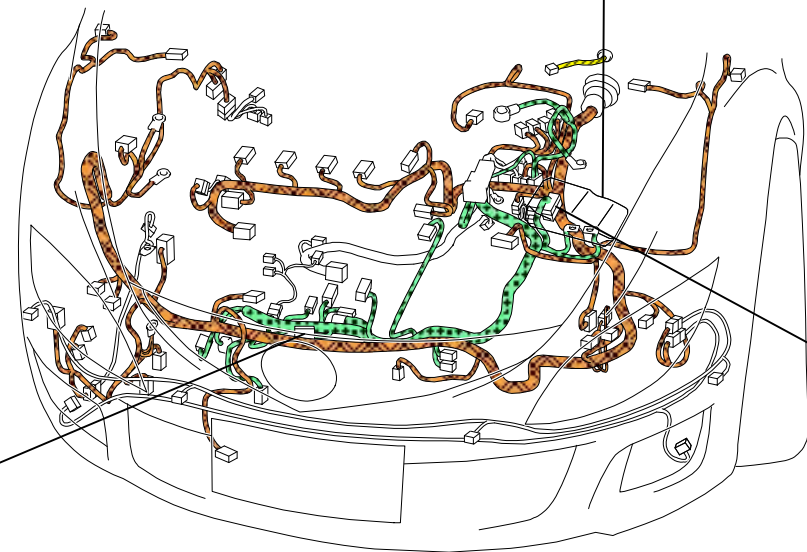

(REFER TO 00F SECTION)
MAIN FUSE BLOCK
F-01



0740-301
MAGNETIC CLUTCH
[GRAY]

C-02
(F)-(E)
[GRAY]

[MZR-CD (RF Turbo)]

-  : FRONT HARNESS
-  : ENGINE HARNESS
-  : INJECTION HARNESS
-  : REAR HARNESS

C-02
FRONT HARNESS-ENGINE HARNESS

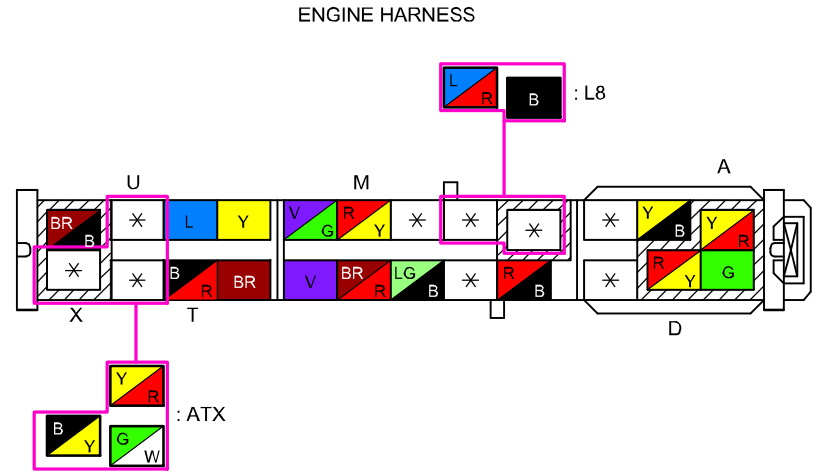
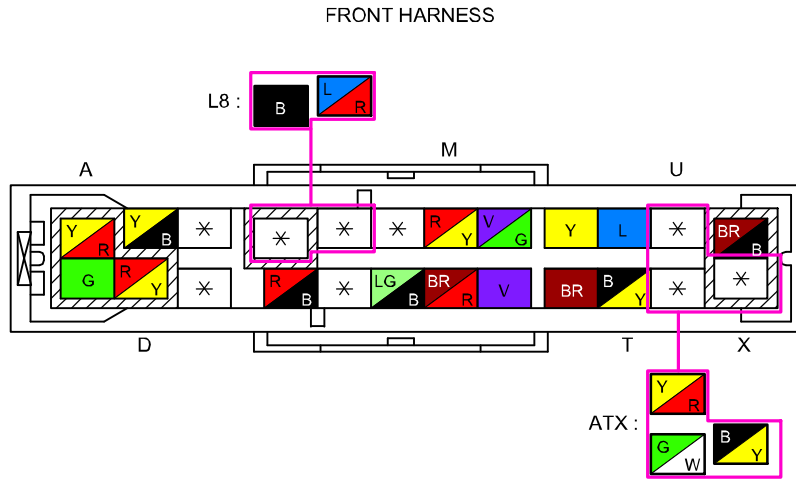

(EXCEPT MZR-CD (RF Turbo))

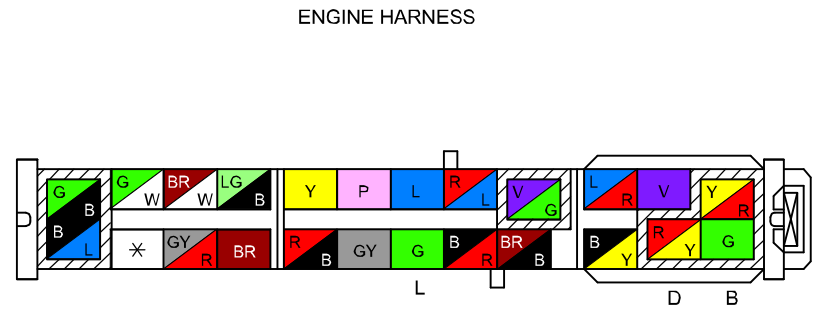
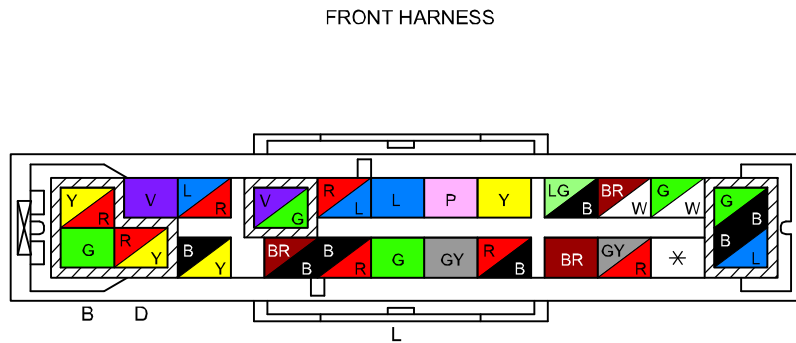

(MZR-CD (RF Turbo))

WATER HEATER SYSTEM

0740-4

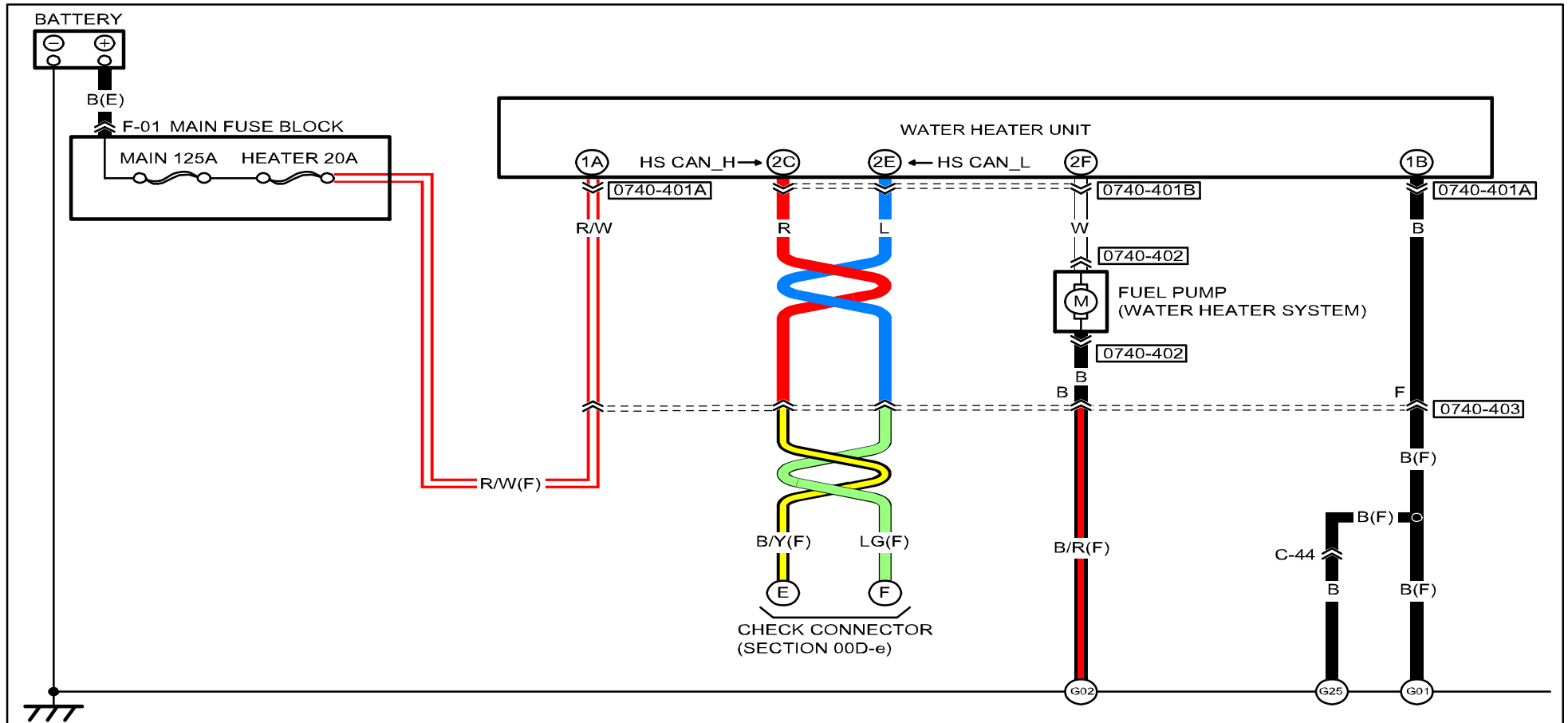

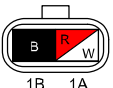
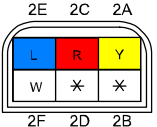
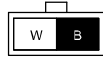
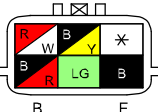
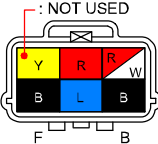
<p>0740-401A WATER HEATER UNIT</p> 	<p>0740-401B WATER HEATER UNIT</p> 	<p>0740-402 FUEL PUMP (WATER HEATER SYSTEM)</p> 	
<p>0740-403 FRONT HARNESS-SHORT CORD</p>	<p>FRONT HARNESS</p>  <p>SHORT CORD</p> <p>: NOT USED</p> 		

WATER HEATER SYSTEM

0740-4

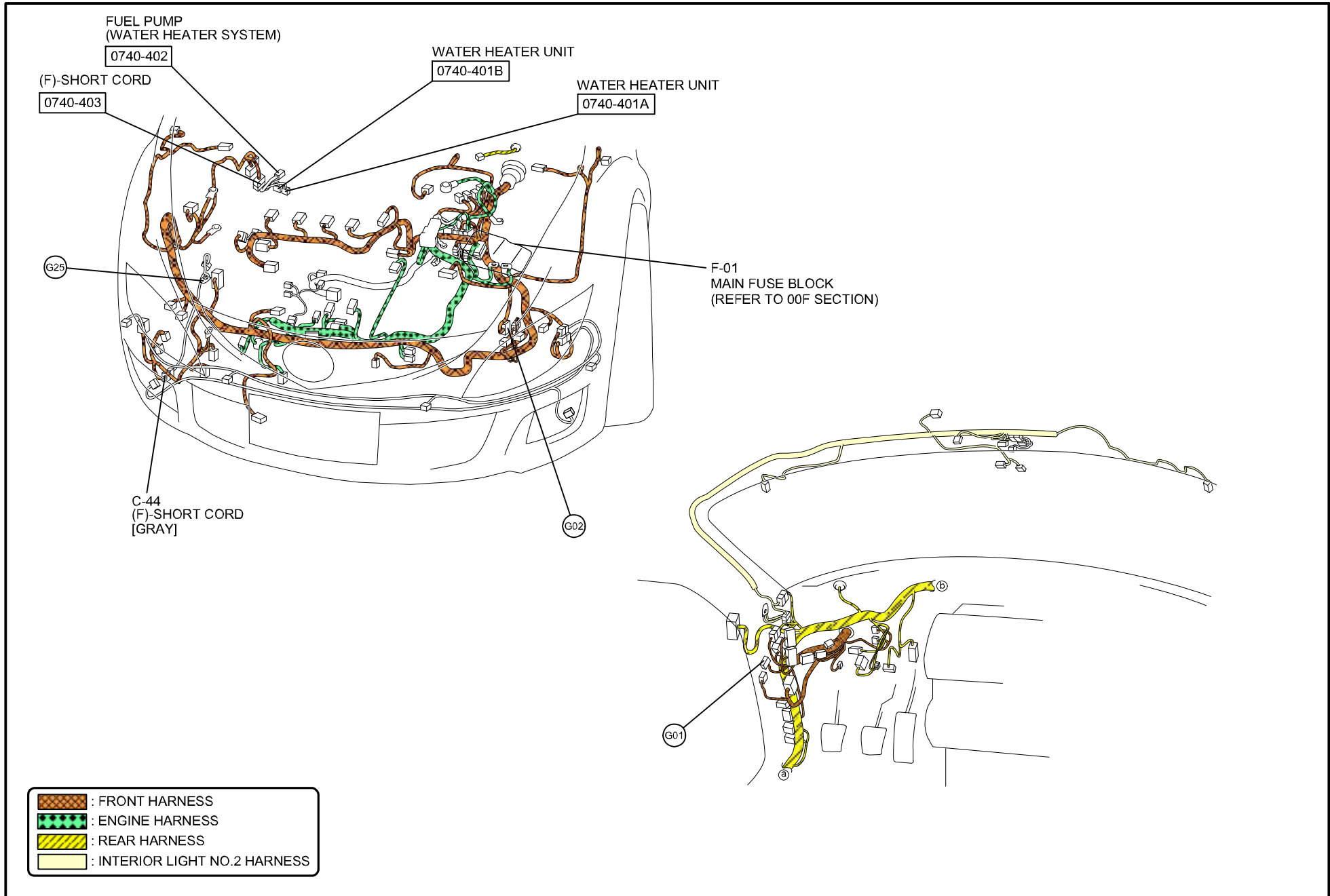

C-44
FRONT HARNESS-SHORT CORD

FRONT HARNESS

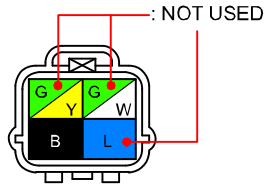

(WITH HEADLIGHT MANUAL LEVELING SYSTEM)

SHORT CORD

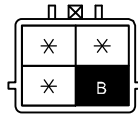

FRONT HARNESS

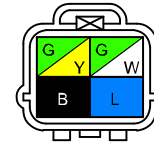

(WITH HEADLIGHT AUTO LEVELING SYSTEM)

SHORT CORD

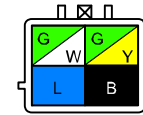

AIR BAG SYSTEM (INCLUDES PRE-TENSIONER SEAT BELT INFORMATION)

0810-a

IGNITION SWITCH (IG1) ← @1
 (SECTION 0921-1a)
 IG1 RELAY ← @2
 (SECTION 0921-2a)

@1 : WITHOUT ADVANCED KEYLESS SYSTEM
 @2 : WITH ADVANCED KEYLESS SYSTEM
 #5 : WITH PASSENGER AIR BAG DEACTIVATION (PAD) SWITCH

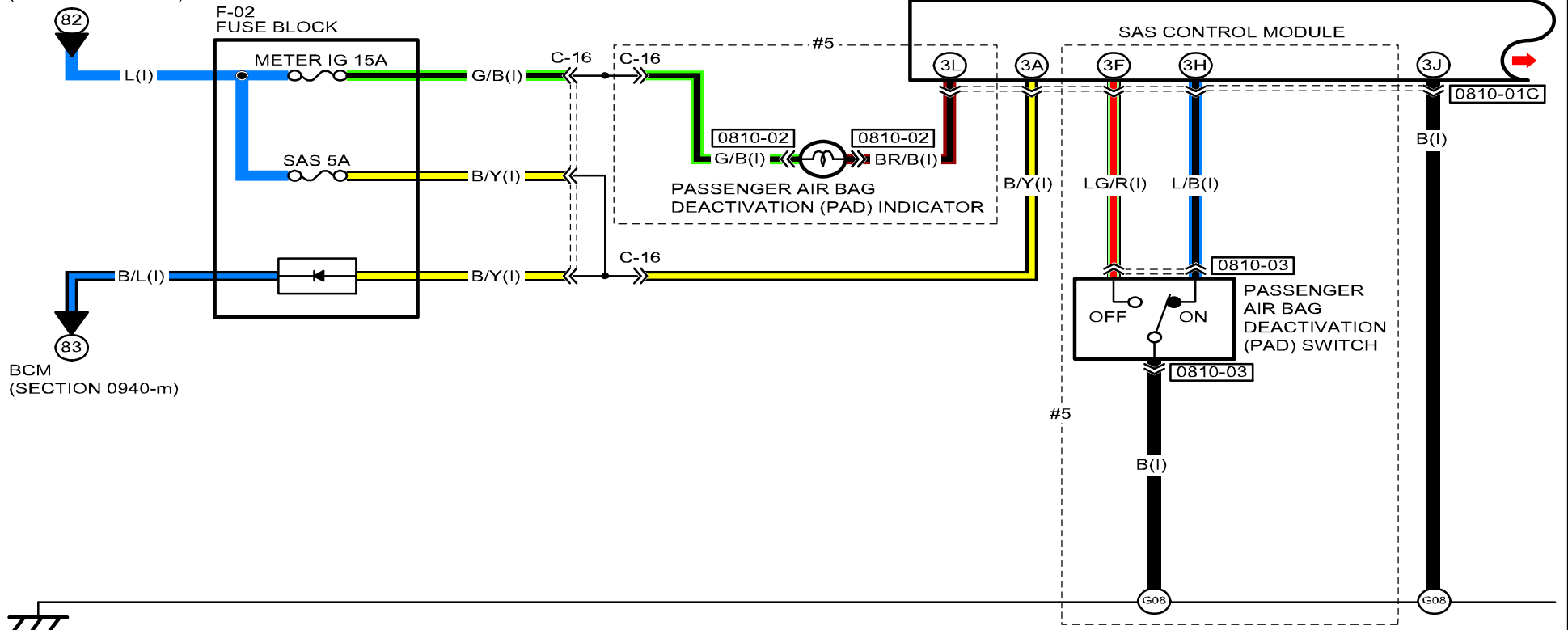

0810-01C
SAS CONTROL MODULE

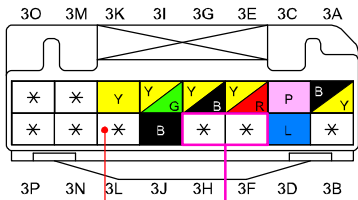

BR B LG R : WITH PASSENGER AIR BAG DEACTIVATION (PAD) SWITCH

0810-02
PASSENGER AIR BAG DEACTIVATION (PAD) INDICATOR

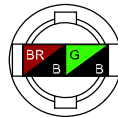

0810-03
PASSENGER AIR BAG DEACTIVATION (PAD) SWITCH

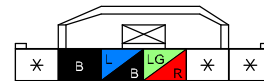

AIR BAG SYSTEM (INCLUDES PRE-TENSIONER SEAT BELT INFORMATION)

0810-a

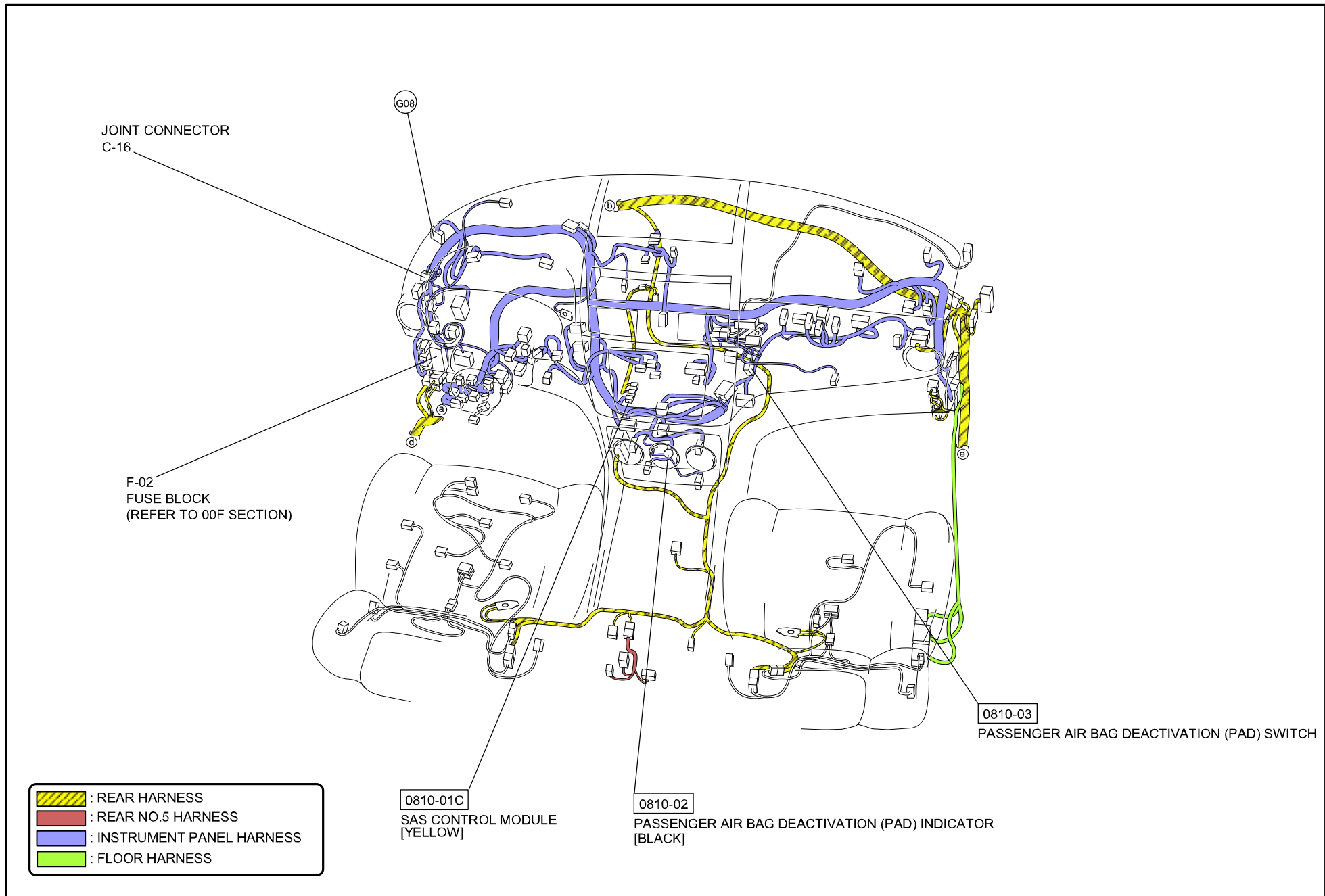

C-16
JOINT CONNECTOR

INSTRUMENT PANEL HARNESS

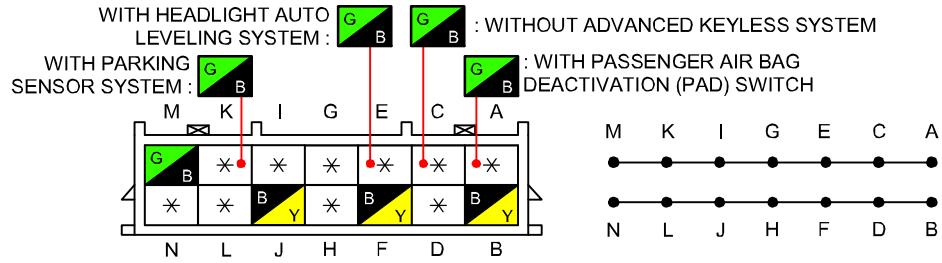

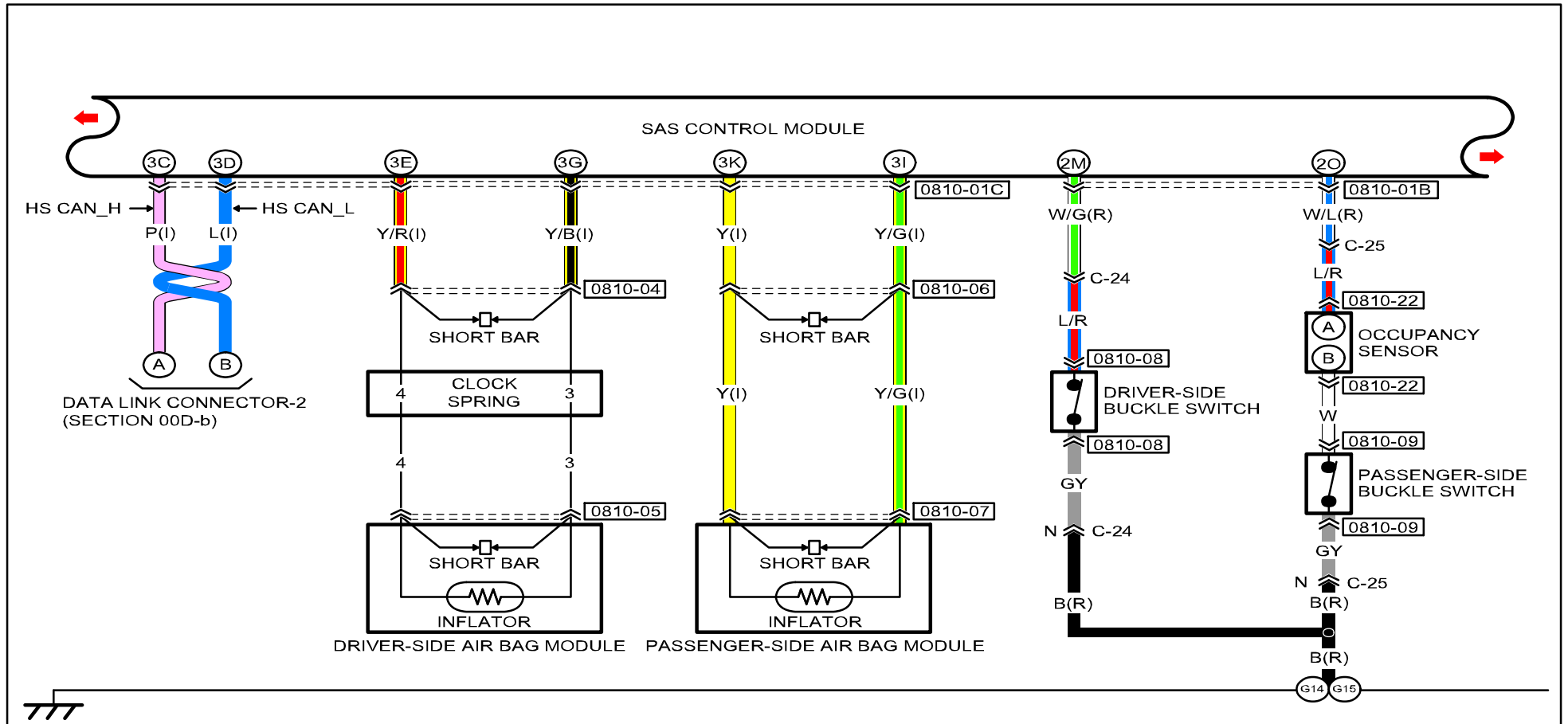

<p>0810-01B SAS CONTROL MODULE</p>	<p>0810-01C SAS CONTROL MODULE</p> <p>: WITH PASSENGER AIR BAG DEACTIVATION (PAD) SWITCH</p>	<p>0810-04 INSTRUMENT PANEL HARNESS-CLOCK SPRING</p> <p>TERMINALS OF THIS CONNECTOR ARE INDICATED BY NUMBERS.</p>	<p>0810-05 DRIVER-SIDE AIR BAG MODULE</p> <p>TERMINALS OF THIS CONNECTOR ARE INDICATED BY NUMBERS.</p>		
<p>0810-06 SHORT CONNECTOR</p>	<p>0810-07 PASSENGER-SIDE AIR BAG MODULE</p>	<p>0810-08 DRIVER-SIDE BUCKLE SWITCH</p> <p>: NOT USED</p>	<p>0810-08 DRIVER-SIDE BUCKLE SWITCH</p> <p>: NOT USED</p>	<p>0810-09 PASSENGER-SIDE BUCKLE SWITCH</p> <p>: NOT USED</p>	<p>0810-22 OCCUPANCY SENSOR</p>

AIR BAG SYSTEM (INCLUDES PRE-TENSIONER SEAT BELT INFORMATION)

0810-b

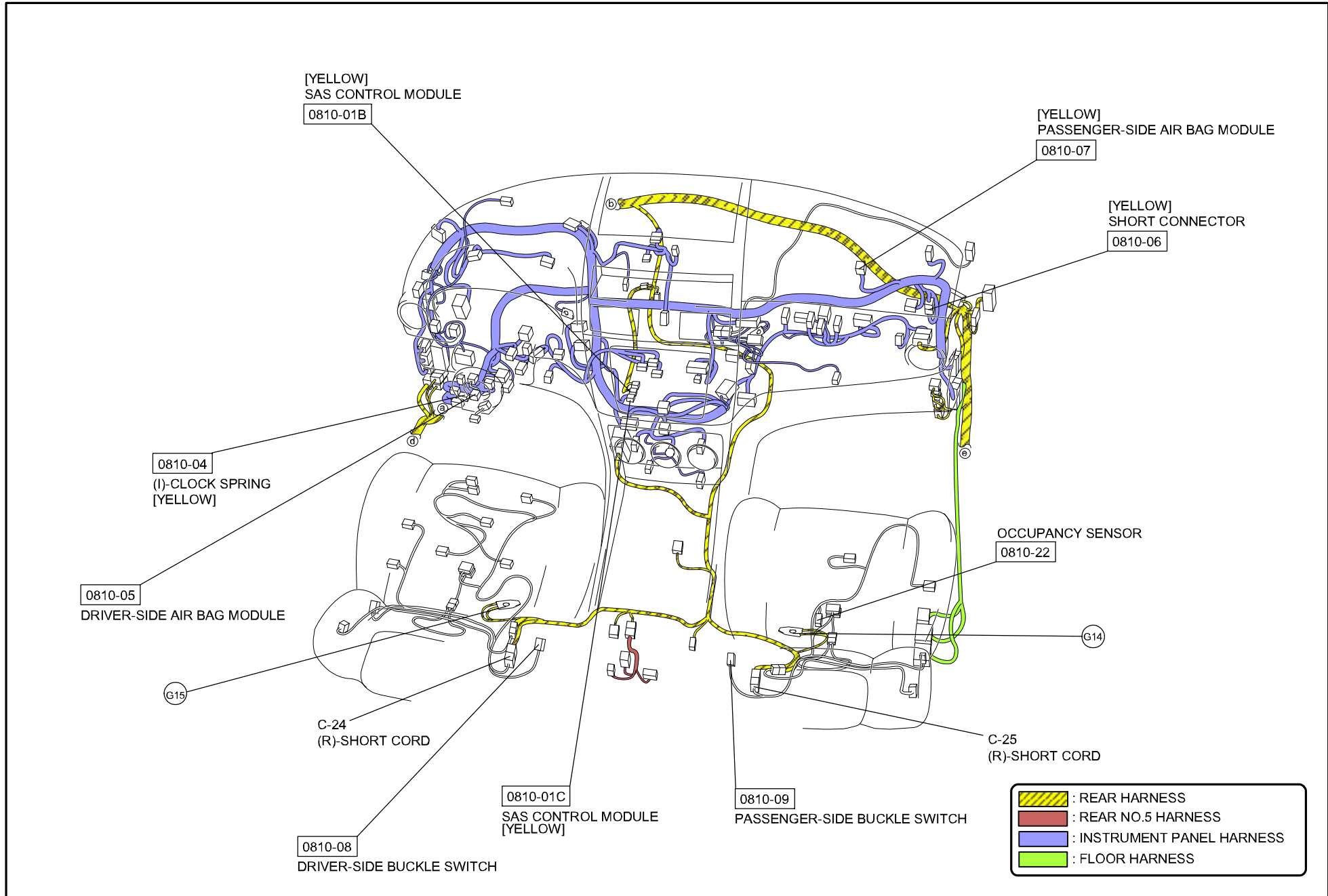

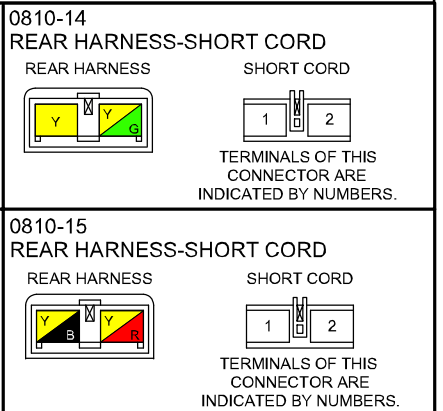
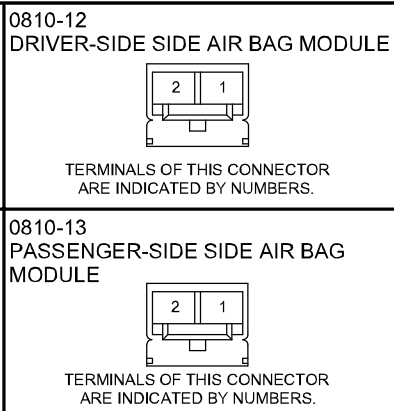
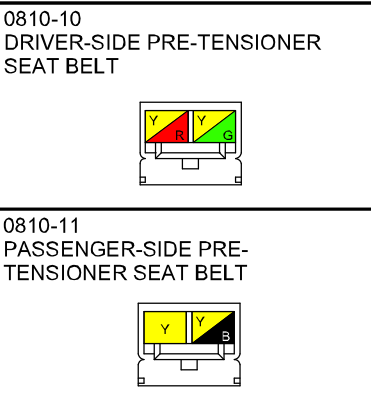
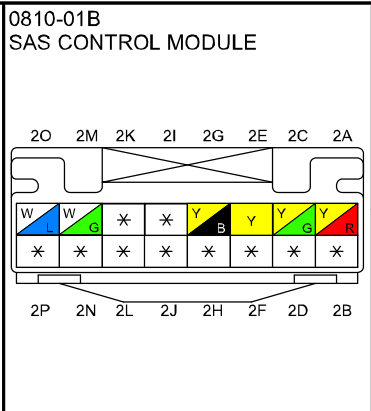
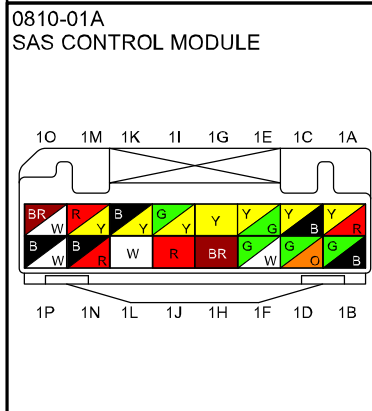
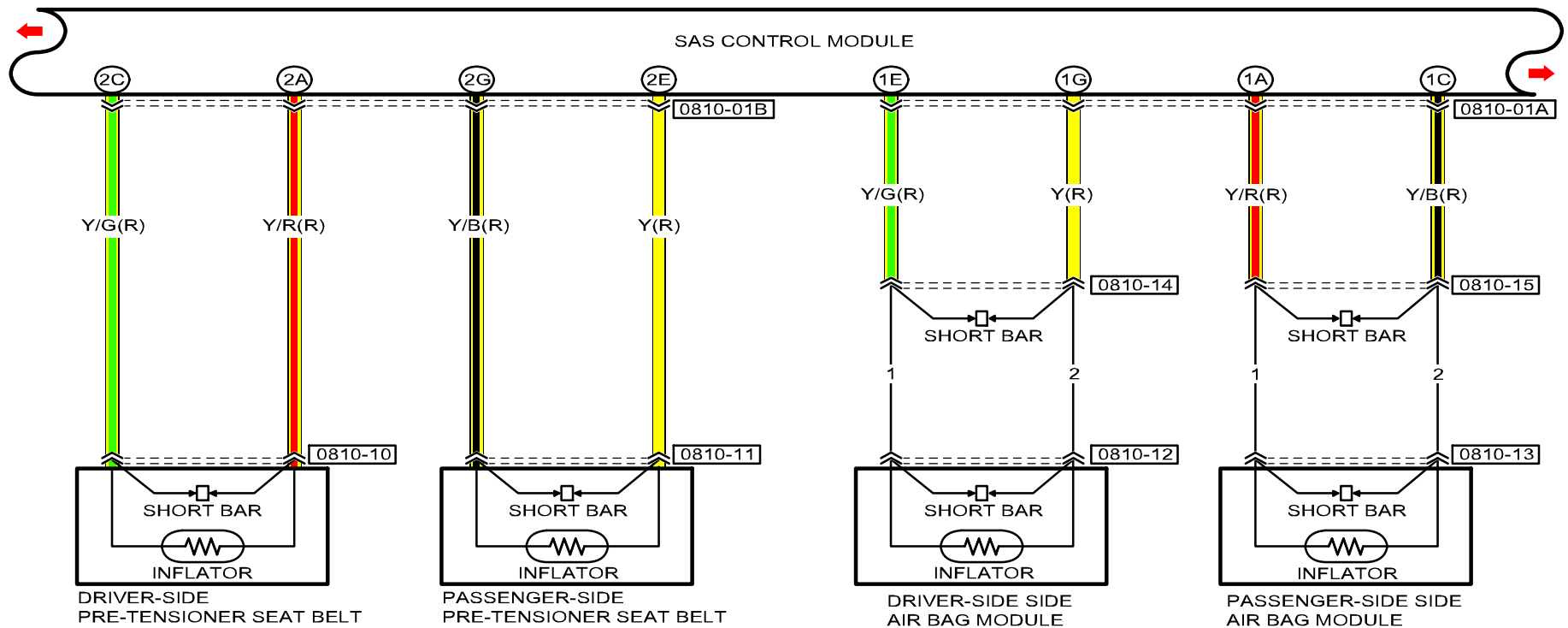

AIR BAG SYSTEM (INCLUDES PRE-TENSIONER SEAT BELT INFORMATION)

0810-c

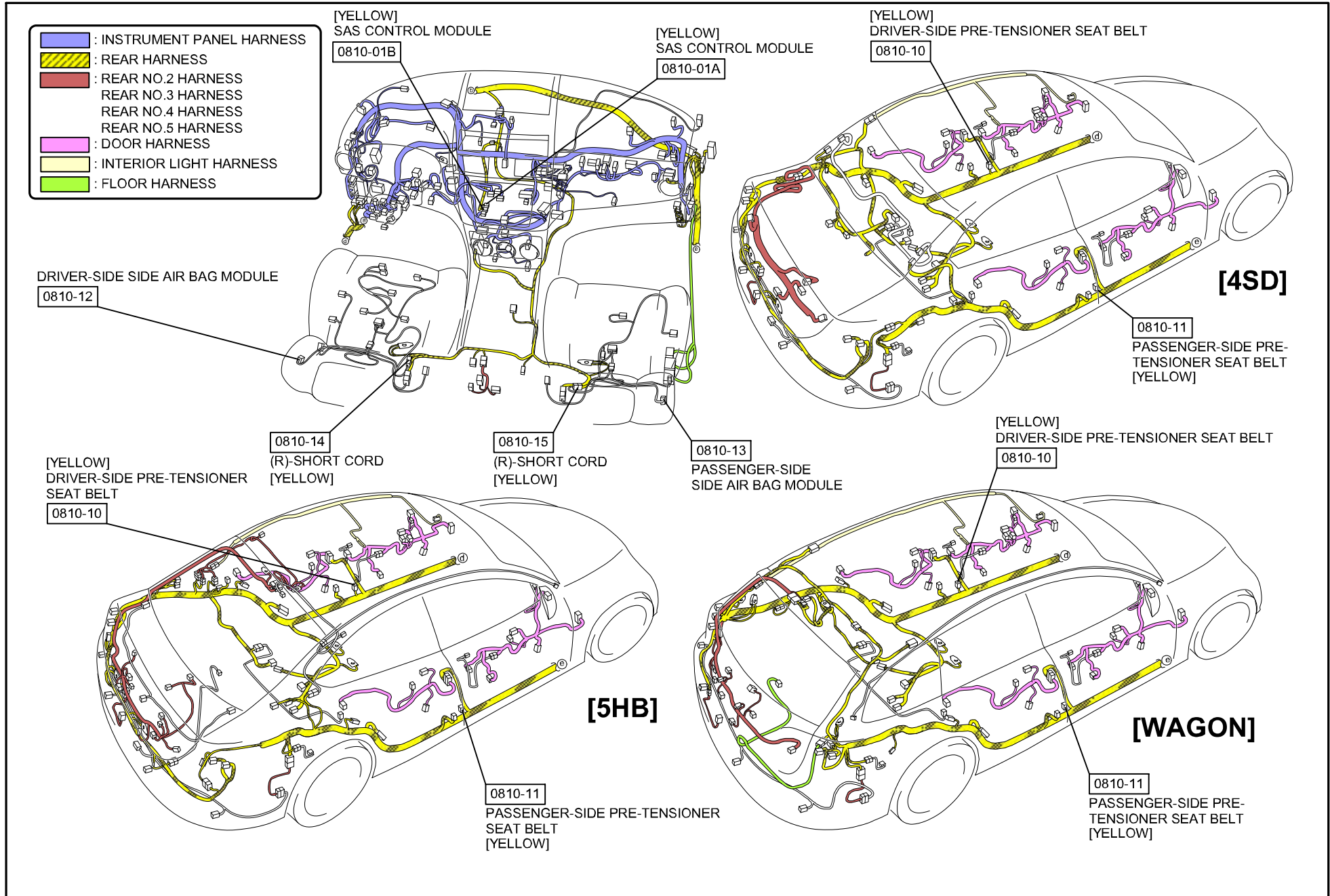

AIR BAG SYSTEM (INCLUDES PRE-TENSIONER SEAT BELT INFORMATION)

0810-d

[] : 5HB

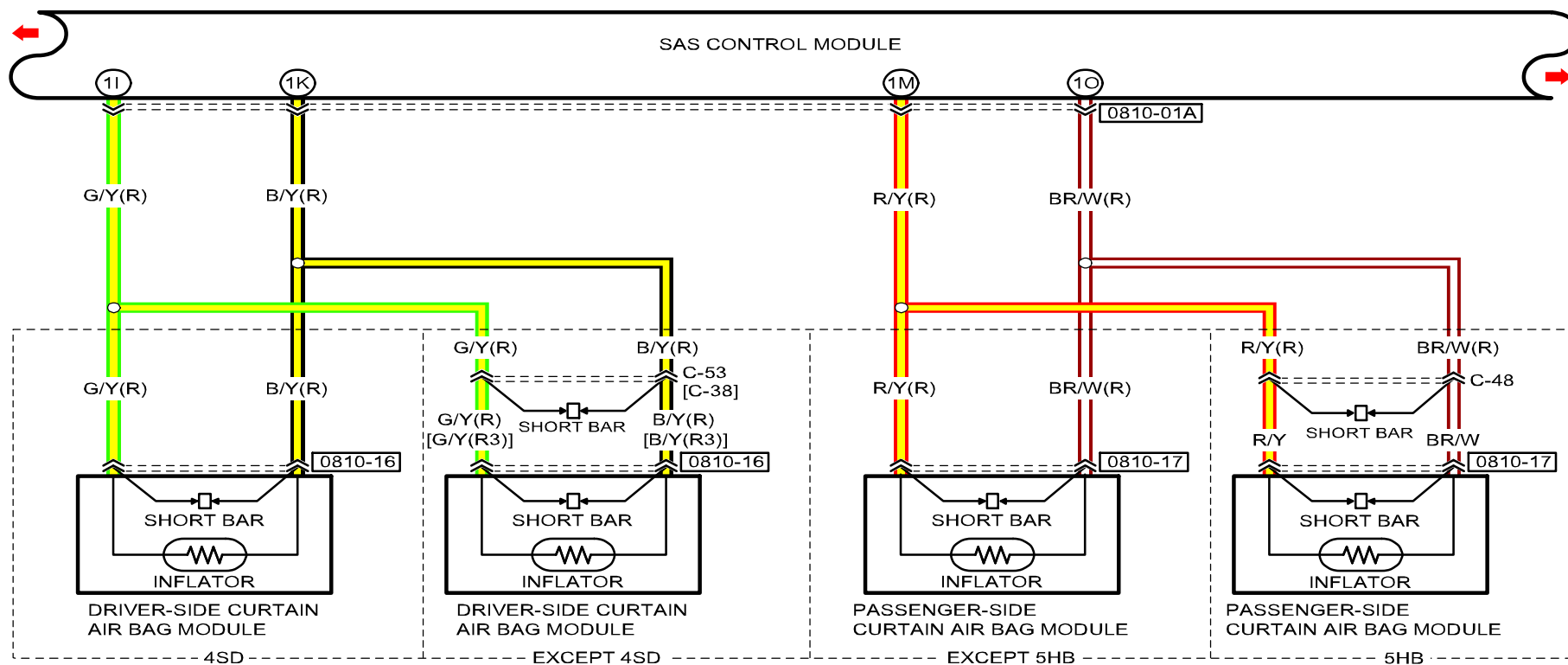

0810-01A
SAS CONTROL MODULE

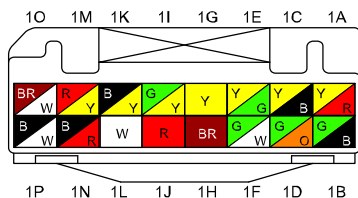

0810-16
DRIVER-SIDE CURTAIN AIR BAG MODULE

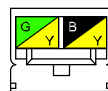

0810-17
PASSENGER-SIDE CURTAIN AIR BAG MODULE



AIR BAG SYSTEM (INCLUDES PRE-TENSIONER SEAT BELT INFORMATION)

0810-d

- : INSTRUMENT PANEL HARNESS
- : REAR HARNESS
- : REAR NO.2 HARNESS
- : REAR NO.3 HARNESS
- : REAR NO.4 HARNESS
- : REAR NO.5 HARNESS
- : DOOR HARNESS
- : INTERIOR LIGHT HARNESS
- : FLOOR HARNESS

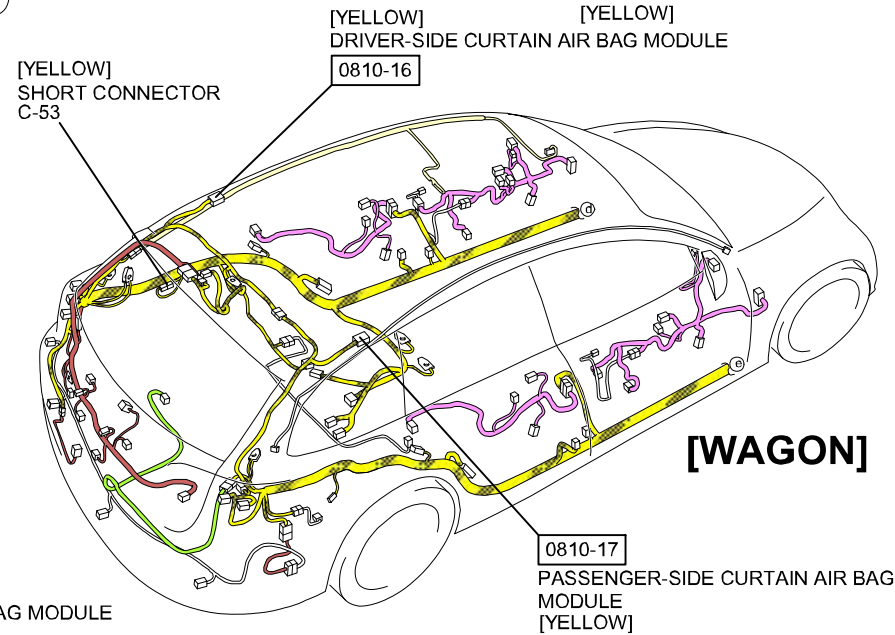
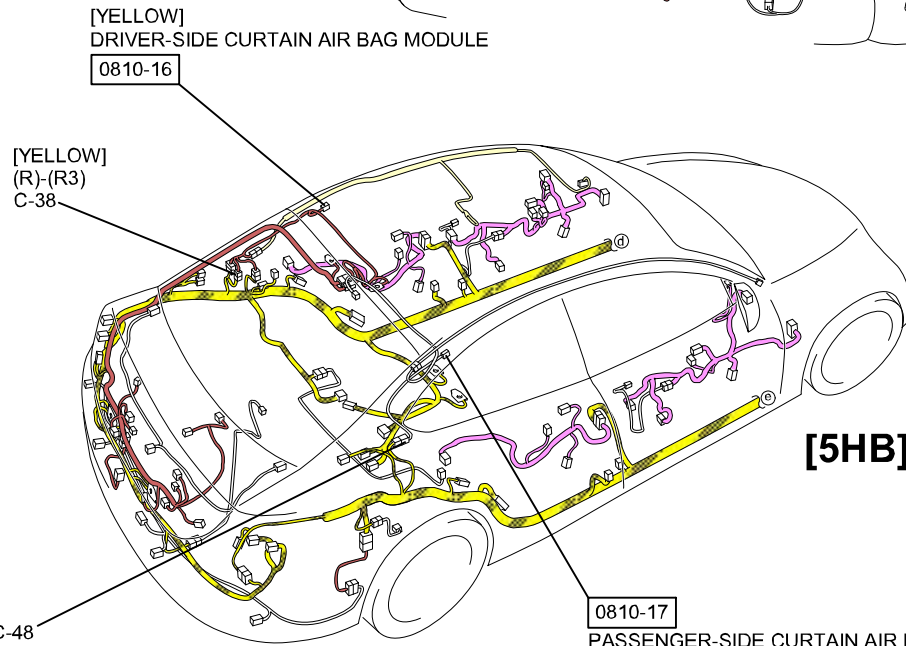
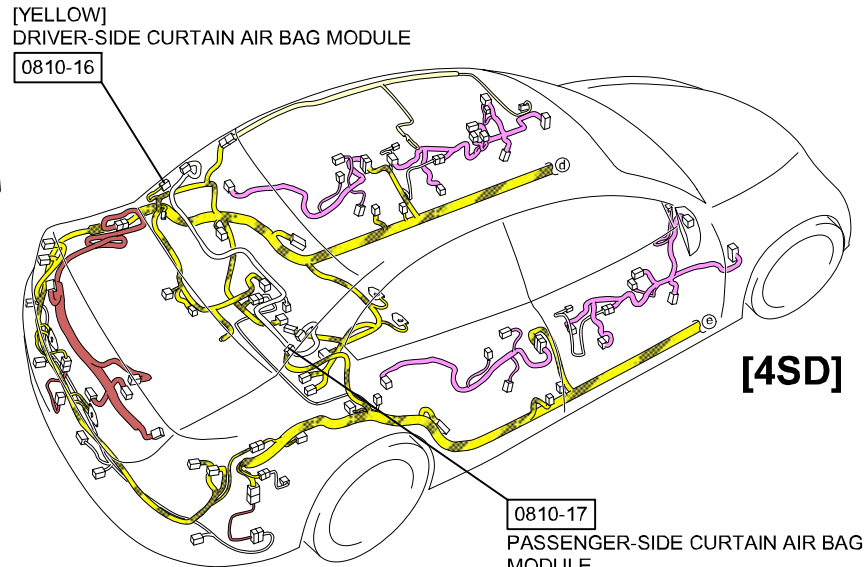
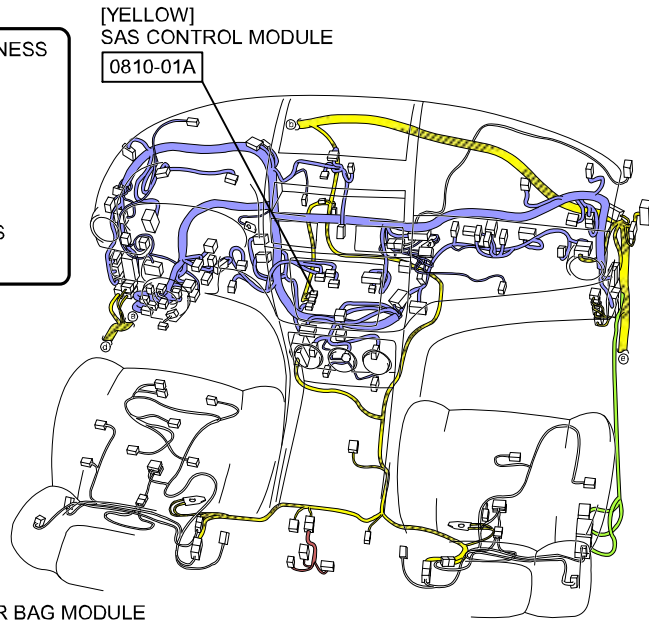

C-48
(R)-SHORT CORD
[YELLOW]

C-38
REAR HARNESS-REAR NO.3 HARNESS

REAR HARNESS

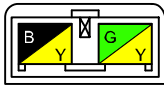

REAR NO.3 HARNESS

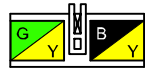

(5HB)

C-48
REAR HARNESS-SHORT CORD

REAR HARNESS

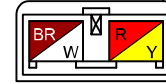

SHORT CORD

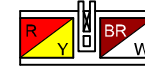

(5HB)

C-53
SHORT CONNECTOR

REAR HARNESS

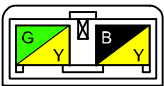

REAR HARNESS

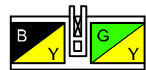

(WAGON)

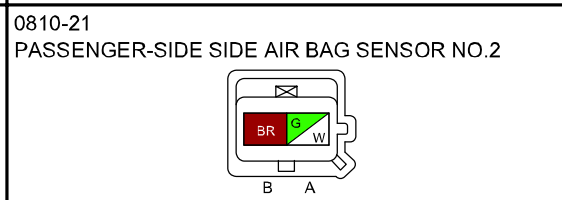
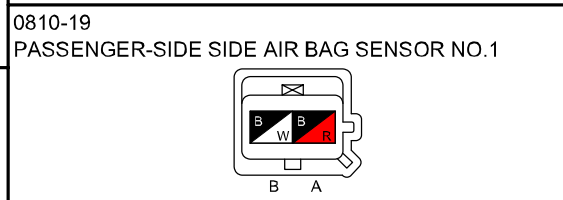
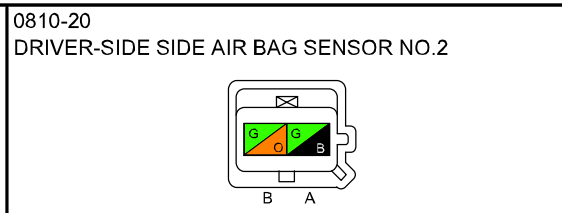
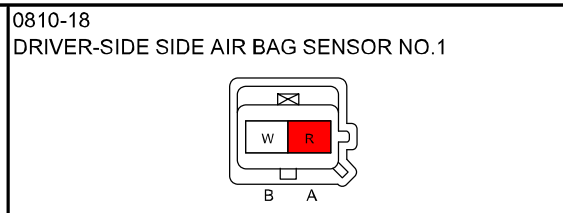
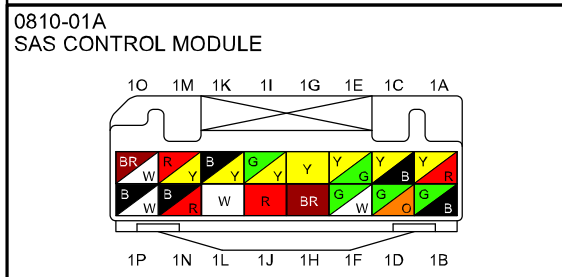
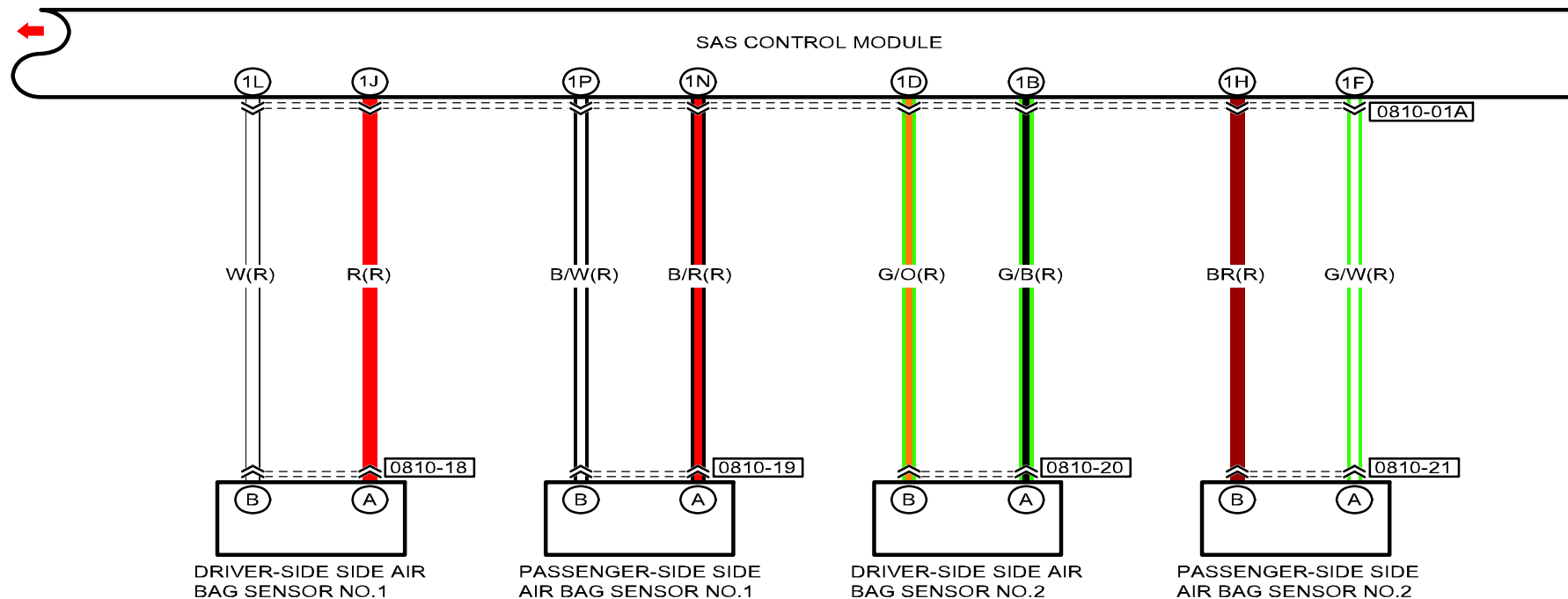

AIR BAG SYSTEM (INCLUDES PRE-TENSIONER SEAT BELT INFORMATION)

0810-e

- : INSTRUMENT PANEL HARNESS
- : REAR HARNESS
- : REAR NO.2 HARNESS
- : REAR NO.3 HARNESS
- : REAR NO.4 HARNESS
- : REAR NO.5 HARNESS
- : DOOR HARNESS
- : INTERIOR LIGHT HARNESS
- : FLOOR HARNESS

[YELLOW]
SAS CONTROL MODULE
0810-01A

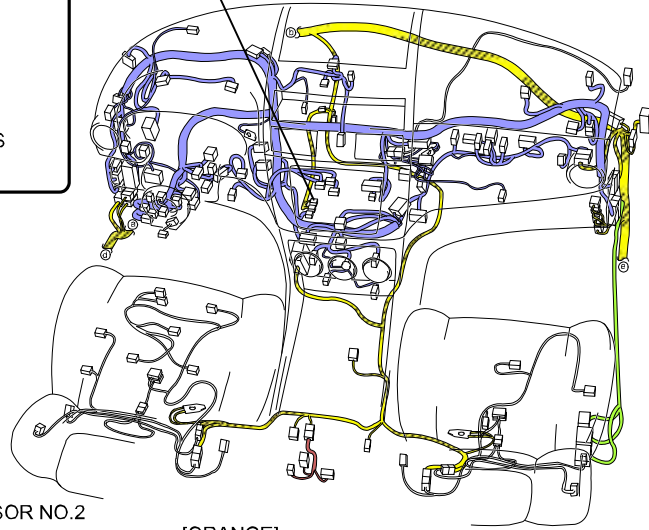

[ORANGE]
DRIVER-SIDE SIDE AIR BAG SENSOR NO.2
0810-20

[ORANGE]
DRIVER-SIDE SIDE AIR BAG SENSOR NO.1
0810-18

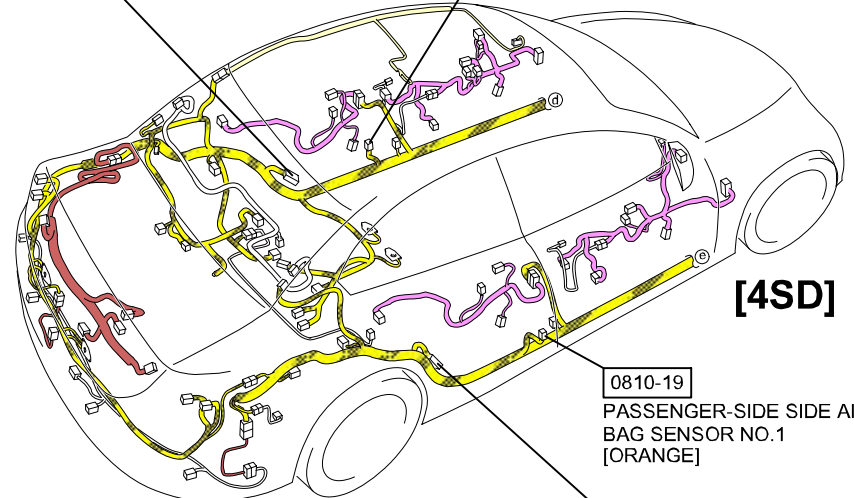

[4SD]

0810-19
PASSENGER-SIDE SIDE AIR BAG SENSOR NO.1
[ORANGE]

0810-21
PASSENGER-SIDE SIDE AIR BAG SENSOR NO.2
[ORANGE]

[ORANGE]
DRIVER-SIDE SIDE AIR BAG SENSOR NO.2
0810-20

[ORANGE]
DRIVER-SIDE SIDE AIR BAG SENSOR NO.1
0810-18

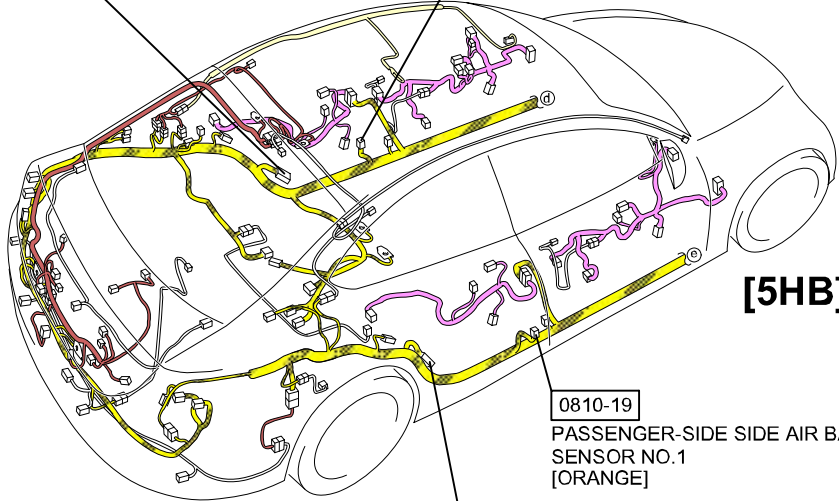

[5HB]

0810-19
PASSENGER-SIDE SIDE AIR BAG SENSOR NO.1
[ORANGE]

0810-21
PASSENGER-SIDE SIDE AIR BAG SENSOR NO.2
[ORANGE]

[ORANGE]
DRIVER-SIDE SIDE AIR BAG SENSOR NO.2
0810-20

[ORANGE]
DRIVER-SIDE SIDE AIR BAG SENSOR NO.1
0810-18

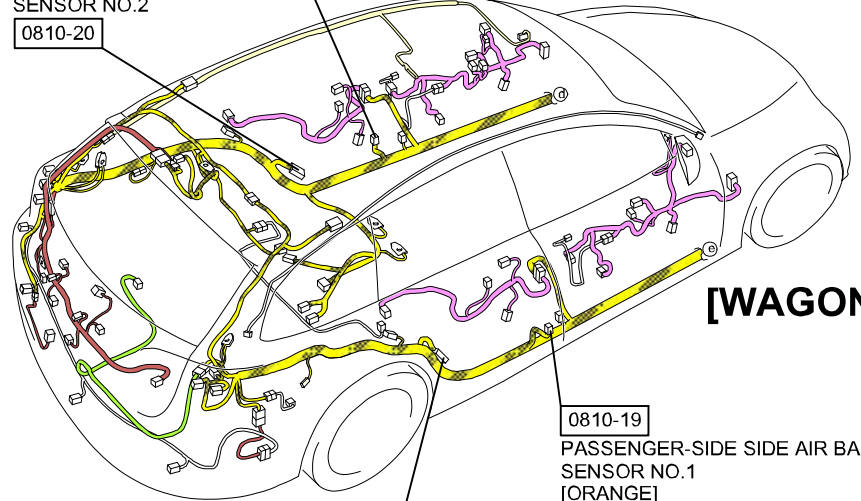

[WAGON]

0810-19
PASSENGER-SIDE SIDE AIR BAG SENSOR NO.1
[ORANGE]

0810-21
PASSENGER-SIDE SIDE AIR BAG SENSOR NO.2
[ORANGE]

REAR WINDOW DEFROSTER (INCLUDES HEATED OUTER MIRROR INFORMATION)

0912-1a

{ } : NAME INDICATED ON FUSE BOX COVER
&5 : MZR-CD (RF Turbo)

0912-1b

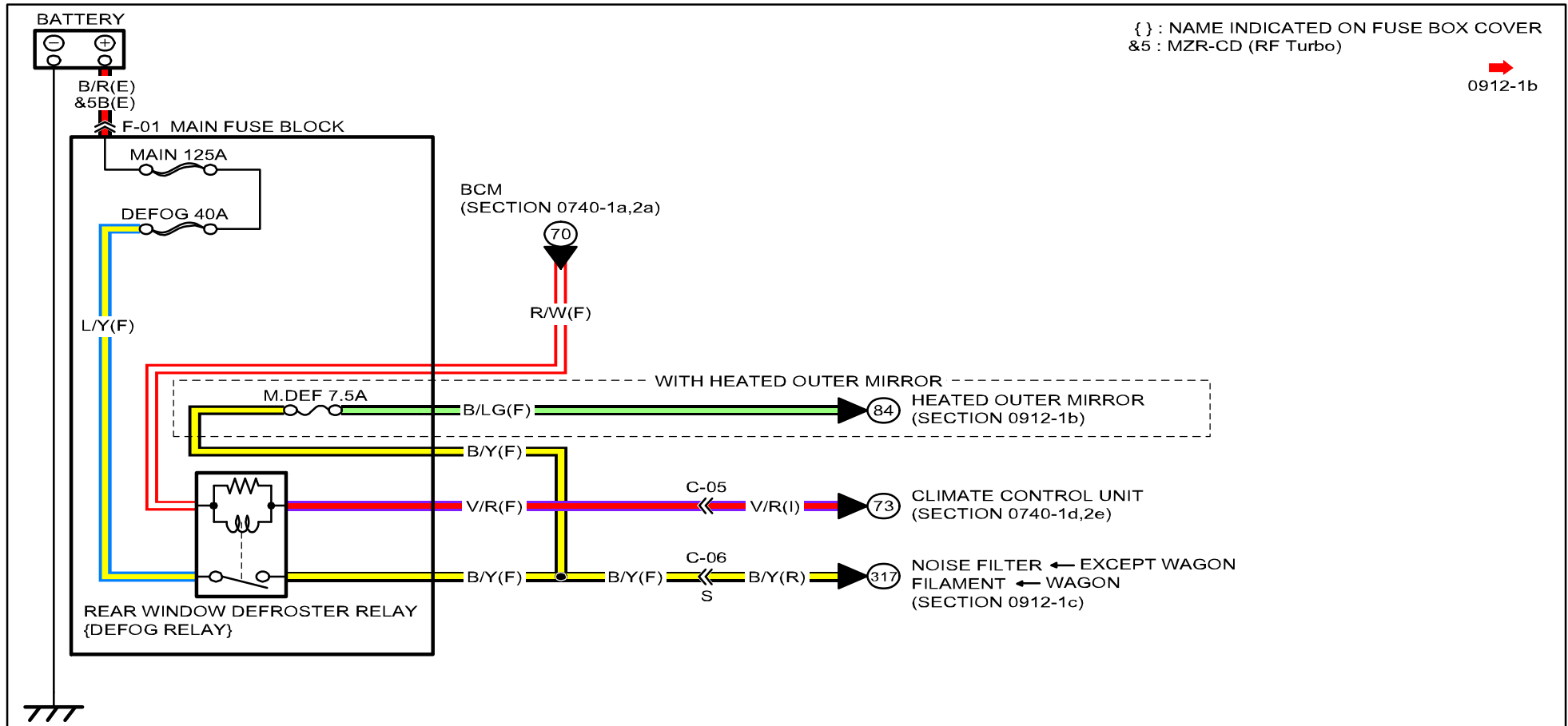

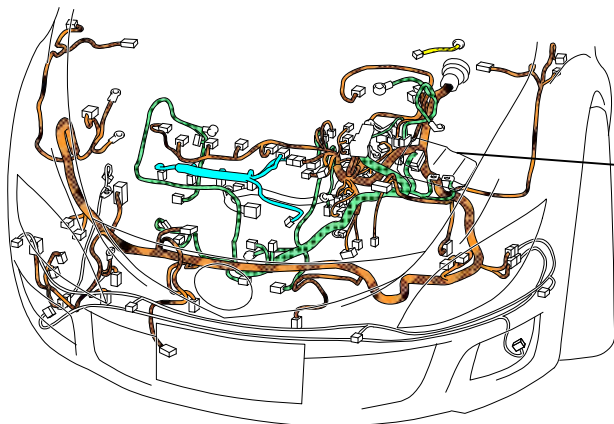

F-01
MAIN FUSE BLOCK
(REFER TO 00F SECTION)

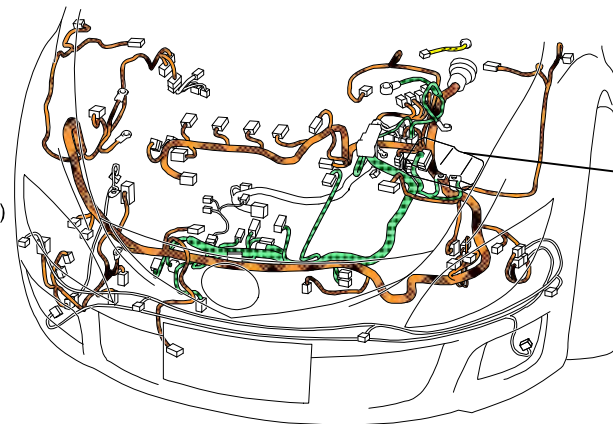

F-01
MAIN FUSE BLOCK
(REFER TO 00F SECTION)

[EXCEPT MZR-CD (RF Turbo)]

[MZR-CD (RF Turbo)]



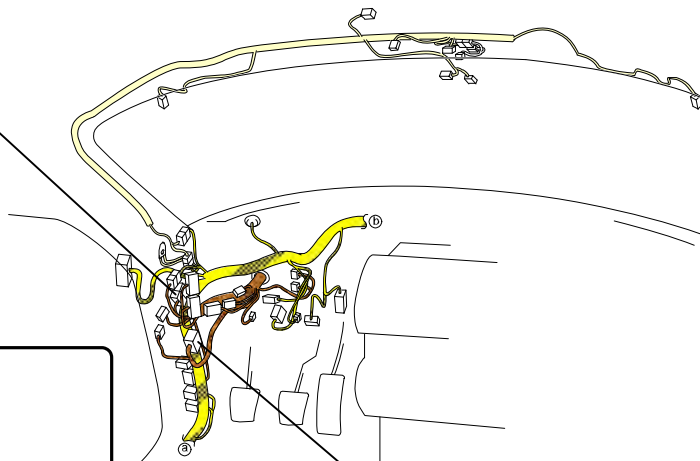



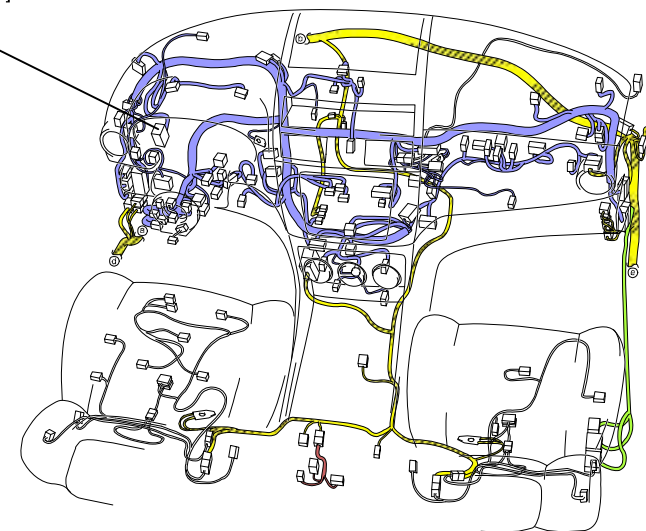

[BLUE]
(F)-(R)
C-06



C-05
(F)-(L)
[BLUE]

[BLUE]
(F)-(L)
C-05



-  : FRONT HARNESS
-  : ENGINE HARNESS
-  : INJECTION HARNESS
-  : REAR HARNESS
-  : REAR NO.5 HARNESS
-  : INSTRUMENT PANEL HARNESS
-  : FLOOR HARNESS
-  : INTERIOR LIGHT NO.2 HARNESS

REAR WINDOW DEFROSTER (INCLUDES HEATED OUTER MIRROR INFORMATION)

0912-1b

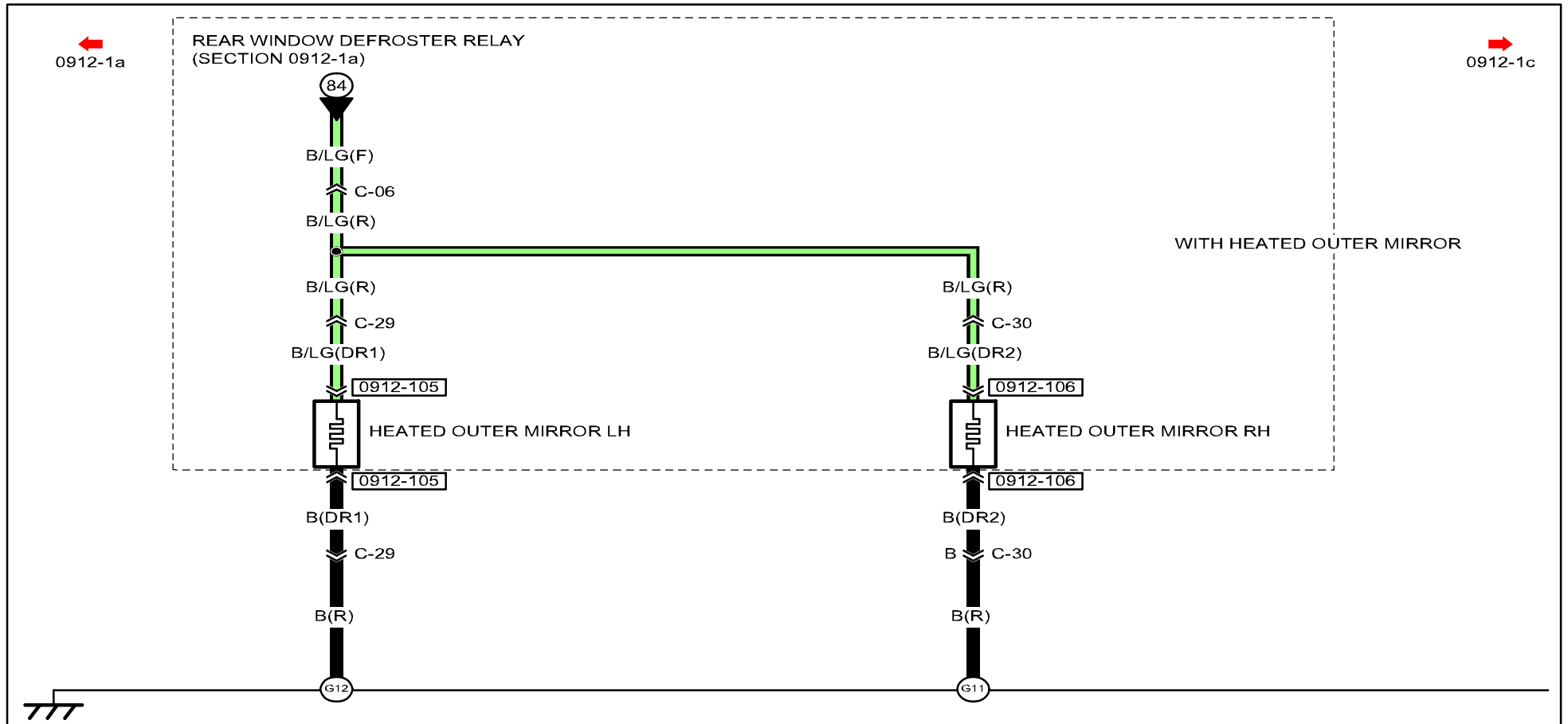

<p>0912-105 HEATED OUTER MIRROR LH / POWER OUTER MIRROR LH / RETRACTABLE OUTER MIRROR LH / FRONT SIDE TURN LIGHT (BUILT INTO OUTER MIRROR) LH</p>	<p>0912-106 HEATED OUTER MIRROR RH / POWER OUTER MIRROR RH / RETRACTABLE OUTER MIRROR RH / FRONT SIDE TURN LIGHT (BUILT INTO OUTER MIRROR) RH</p>			
---	---	--	--	--

REAR WINDOW DEFROSTER (INCLUDES HEATED OUTER MIRROR INFORMATION)

0912-1b

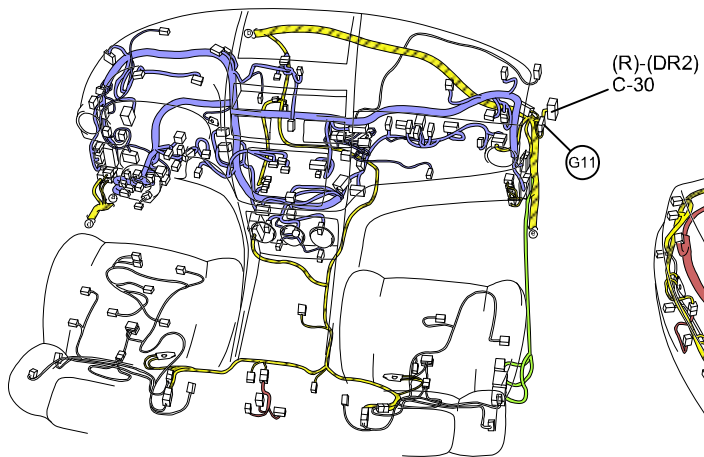

HEATED OUTER MIRROR LH /
POWER OUTER MIRROR LH /
RETRACTABLE OUTER MIRROR LH /
FRONT SIDE TURN LIGHT (BUILT INTO OUTER MIRROR) LH

0912-105

HEATED OUTER MIRROR RH /
POWER OUTER MIRROR RH /
RETRACTABLE OUTER MIRROR RH /
FRONT SIDE TURN LIGHT
(BUILT INTO OUTER MIRROR) RH

0912-106

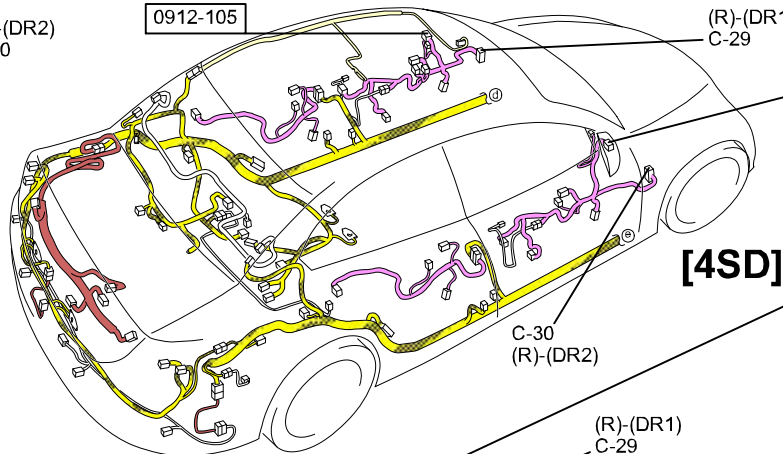

[4SD]

HEATED OUTER MIRROR LH /
POWER OUTER MIRROR LH /
RETRACTABLE OUTER MIRROR LH /
FRONT SIDE TURN LIGHT
(BUILT INTO OUTER MIRROR) LH

0912-105

HEATED OUTER MIRROR RH /
POWER OUTER MIRROR RH /
RETRACTABLE OUTER MIRROR RH /
FRONT SIDE TURN LIGHT
(BUILT INTO OUTER MIRROR) RH

0912-106

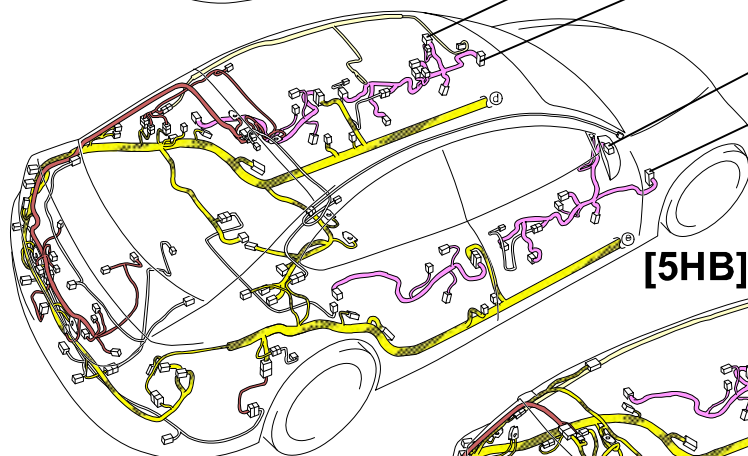
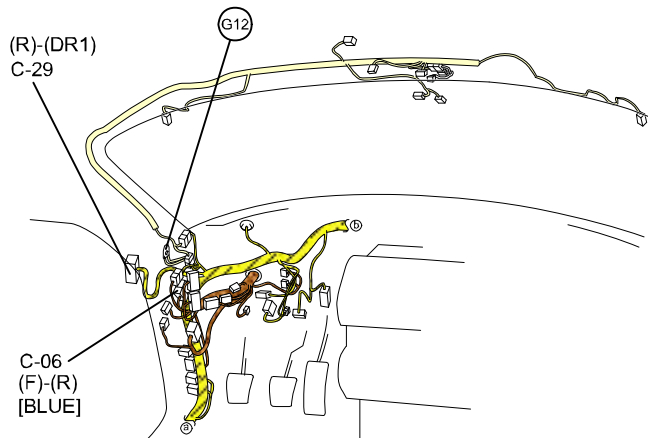

[5HB]

HEATED OUTER MIRROR LH /
POWER OUTER MIRROR LH /
RETRACTABLE OUTER MIRROR LH /
FRONT SIDE TURN LIGHT
(BUILT INTO OUTER MIRROR) LH

0912-105

(R)-(DR1)
C-29

- : FRONT HARNESS
- : REAR HARNESS
- : REAR NO.2 HARNESS
- : REAR NO.3 HARNESS
- : REAR NO.4 HARNESS
- : REAR NO.5 HARNESS
- : INSTRUMENT PANEL HARNESS
- : FLOOR HARNESS
- : INTERIOR LIGHT HARNESS
- : INTERIOR LIGHT NO.2 HARNESS
- : DOOR HARNESS

0912-106

HEATED OUTER MIRROR RH /
POWER OUTER MIRROR RH /
RETRACTABLE OUTER MIRROR RH /
FRONT SIDE TURN LIGHT
(BUILT INTO OUTER MIRROR) RH

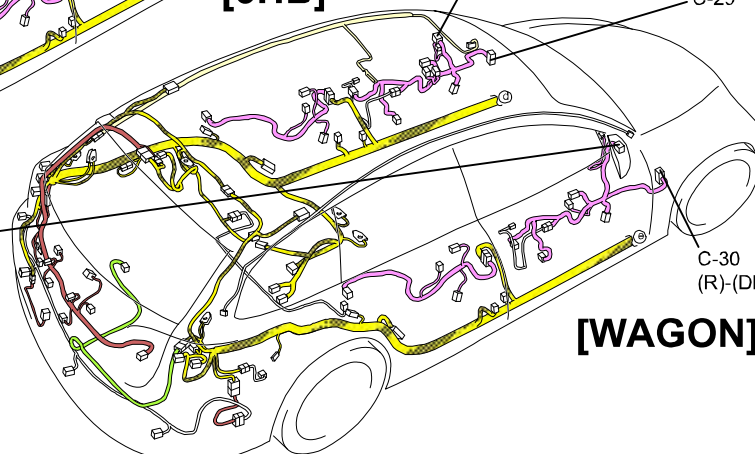

[WAGON]

REAR WINDOW DEFROSTER (INCLUDES HEATED OUTER MIRROR INFORMATION)

0912-1b

C-06

FRONT HARNESS-REAR HARNESS

FRONT HARNESS

REAR HARNESS

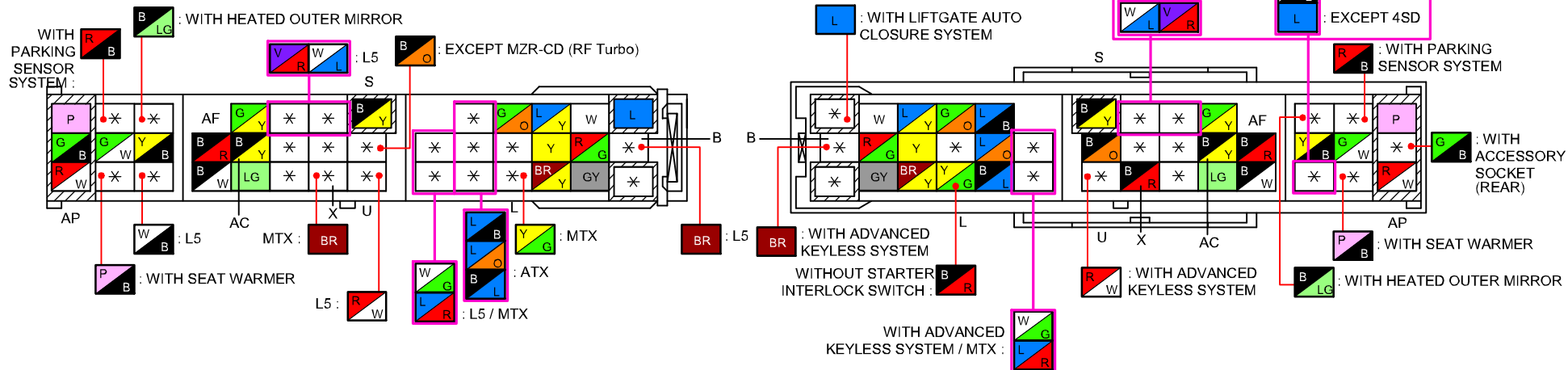

REAR WINDOW DEFROSTER (INCLUDES HEATED OUTER MIRROR INFORMATION)

0912-1b

C-29

REAR HARNESS-DOOR NO.1 HARNESS

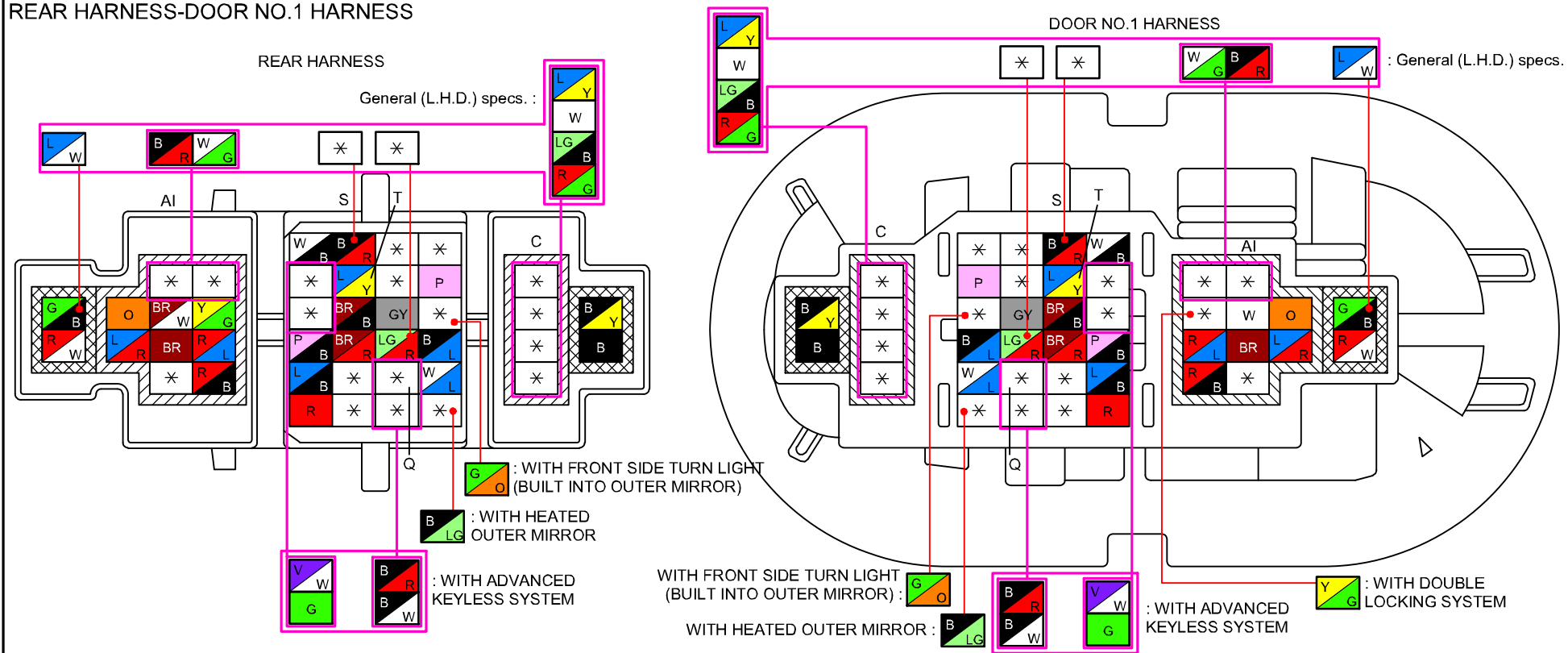

REAR WINDOW DEFROSTER (INCLUDES HEATED OUTER MIRROR INFORMATION)

0912-1c

[] : 5HB

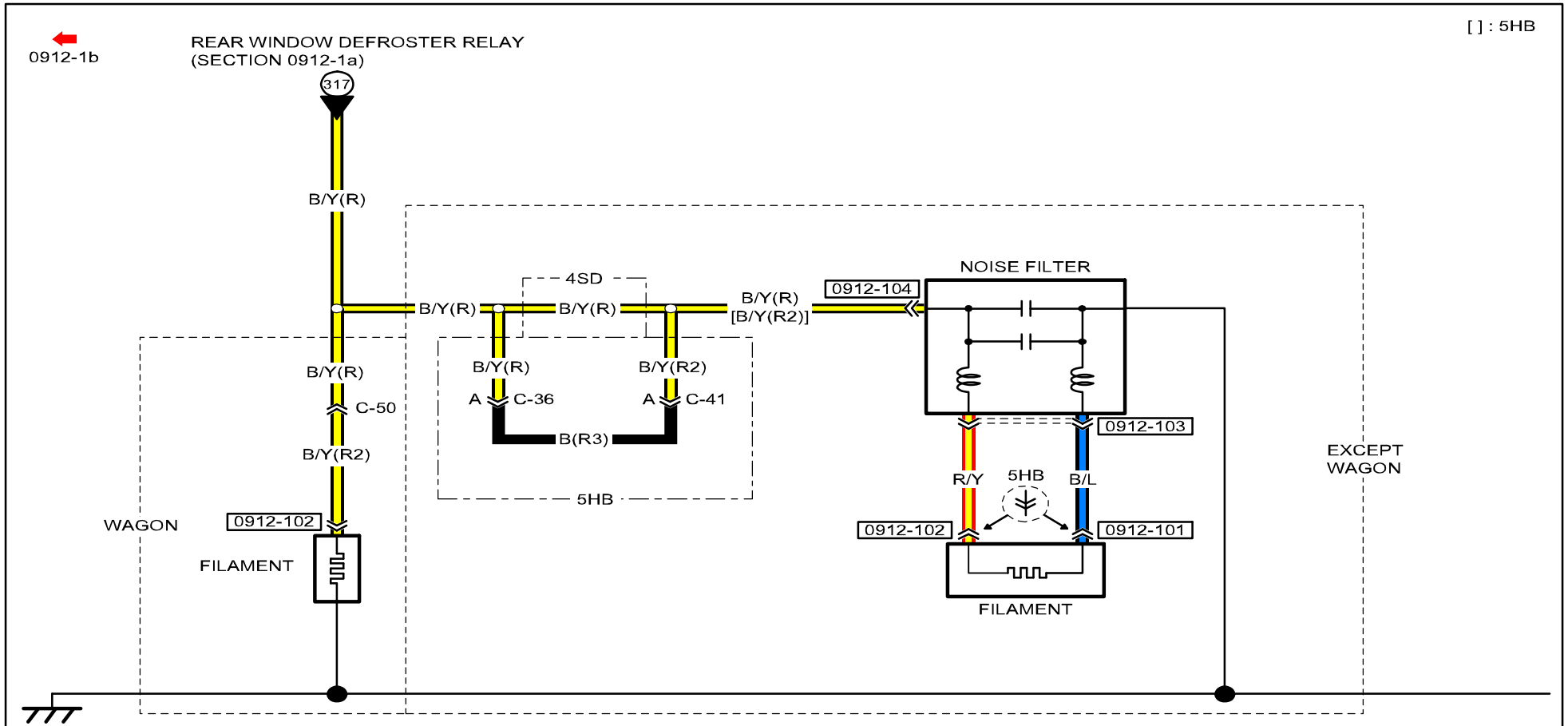

<p>0912-101 FILAMENT</p> <p>(4SD)</p> <p>(5HB)</p>	<p>0912-102 FILAMENT</p> <p>(4SD)</p> <p>(5HB)</p> <p>(WAGON)</p>	<p>0912-103 NOISE FILTER</p>	<p>0912-104 NOISE FILTER</p>	

REAR WINDOW DEFROSTER (INCLUDES HEATED OUTER MIRROR INFORMATION)

0912-1c

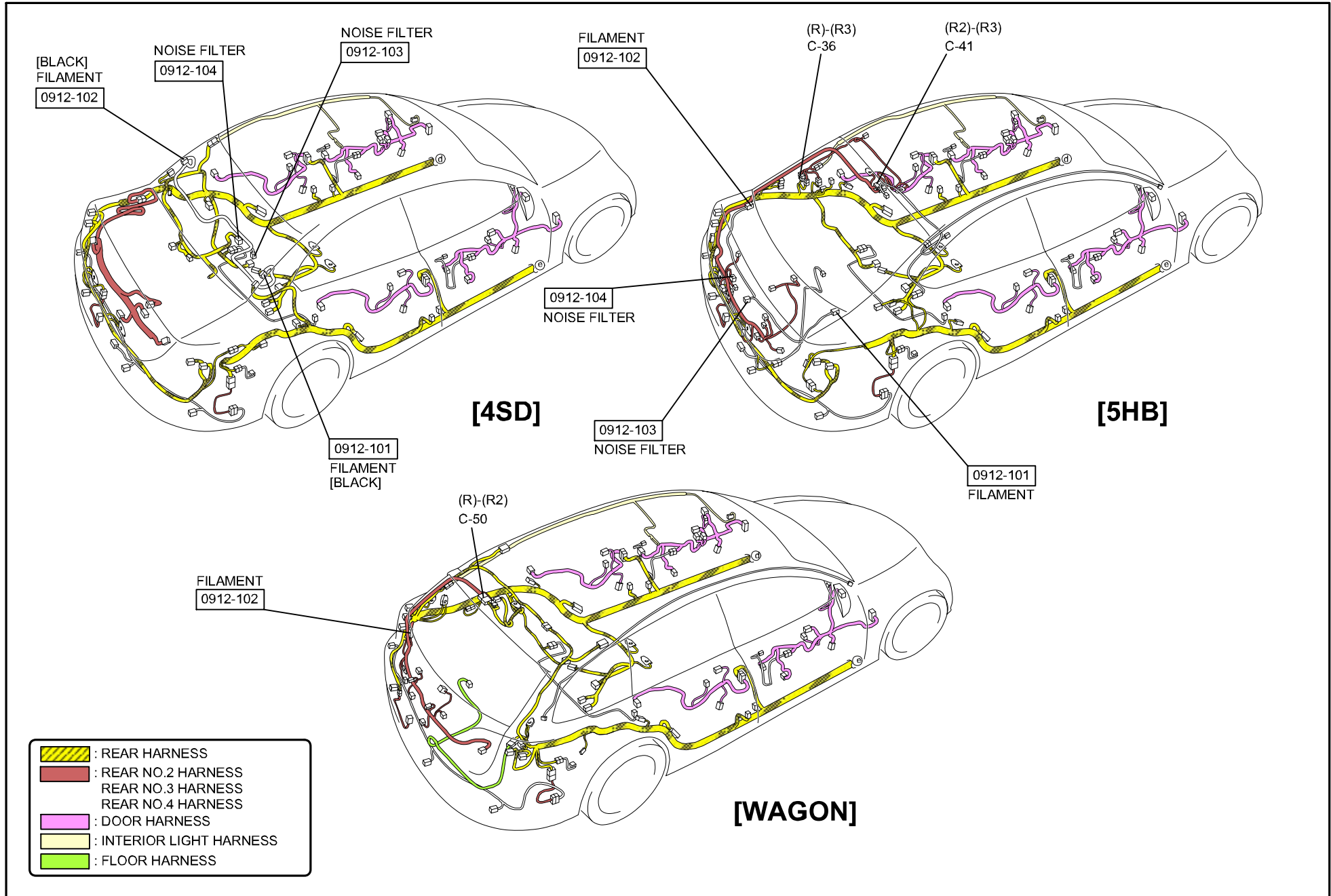

REAR WINDOW DEFROSTER (INCLUDES HEATED OUTER MIRROR INFORMATION)

0912-1c

C-36
REAR HARNESS-REAR NO.3 HARNESS

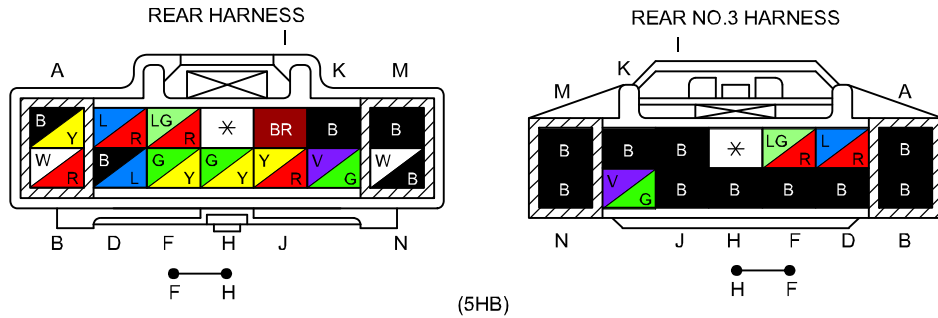

C-41
REAR NO.2 HARNESS-REAR NO.3 HARNESS

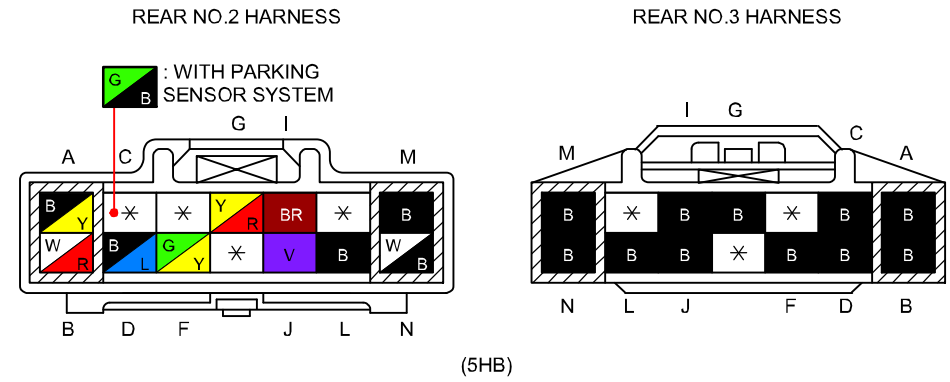

C-50
REAR HARNESS-REAR NO.2 HARNESS

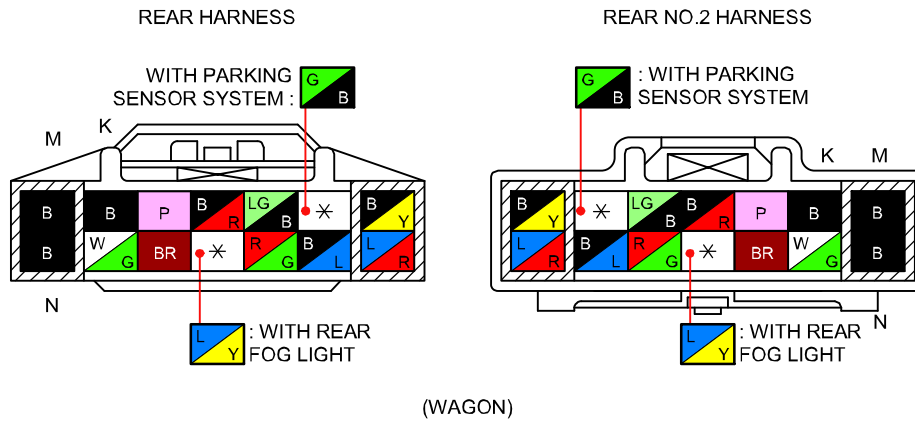

&5 : MZR-CD (RF Turbo)

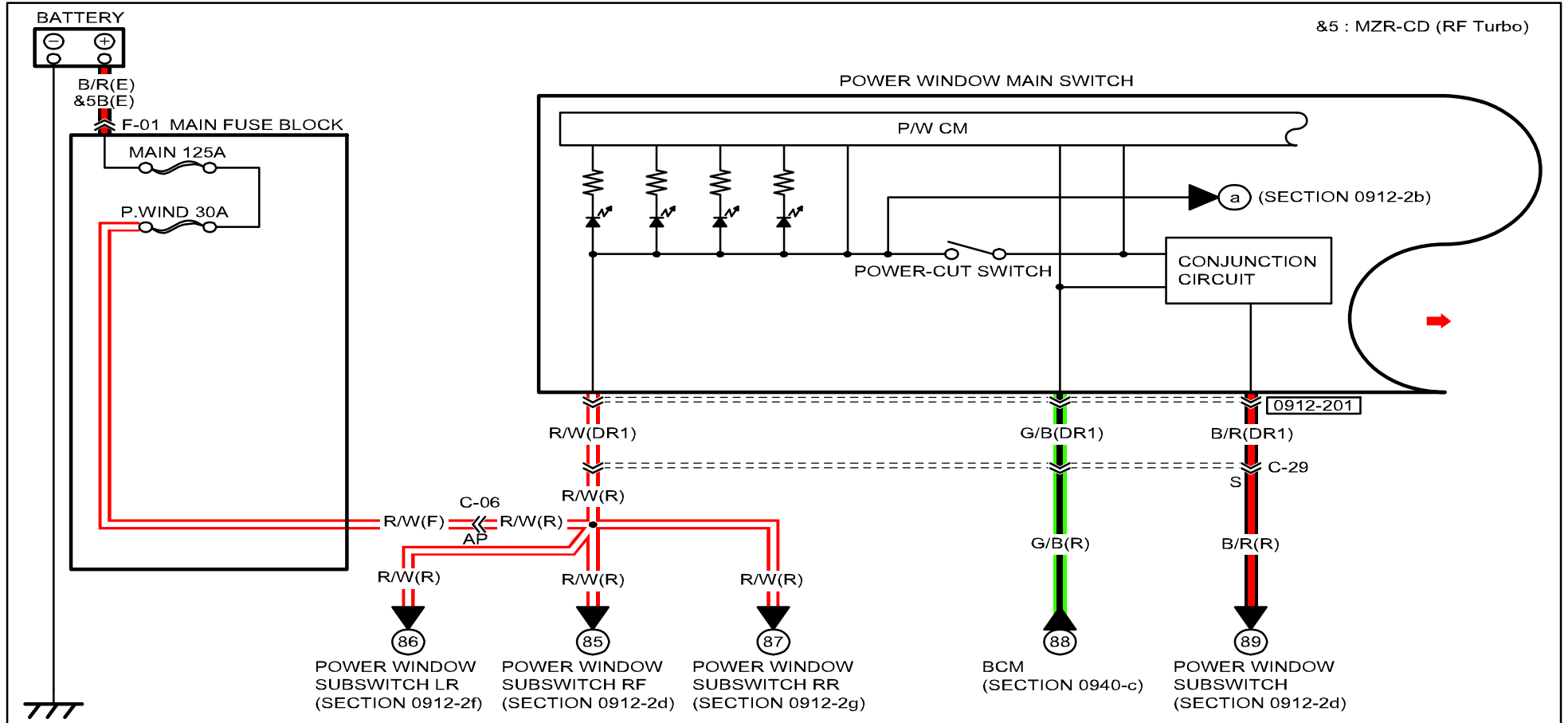

<p>0912-201 POWER WINDOW MAIN SWITCH</p>					

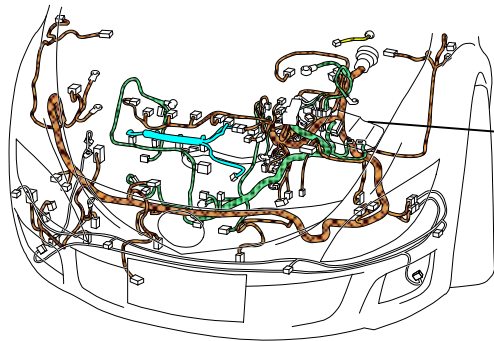

F-01
MAIN FUSE BLOCK
(REFER TO 00F SECTION)

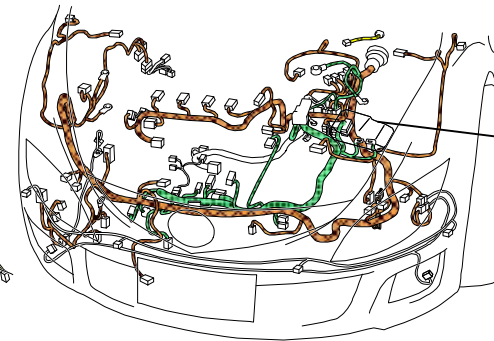

F-01
MAIN FUSE BLOCK
(REFER TO 00F SECTION)

[EXCEPT MZR-CD (RF Turbo)]

[MZR-CD (RF Turbo)]

POWER WINDOW MAIN SWITCH
0912-201

(R)-(DR1)
C-29

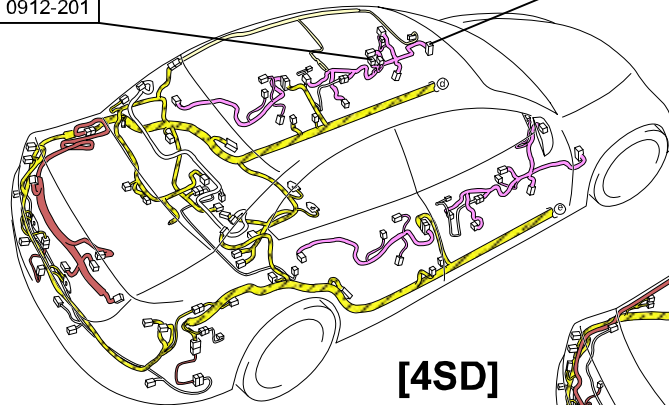

[4SD]

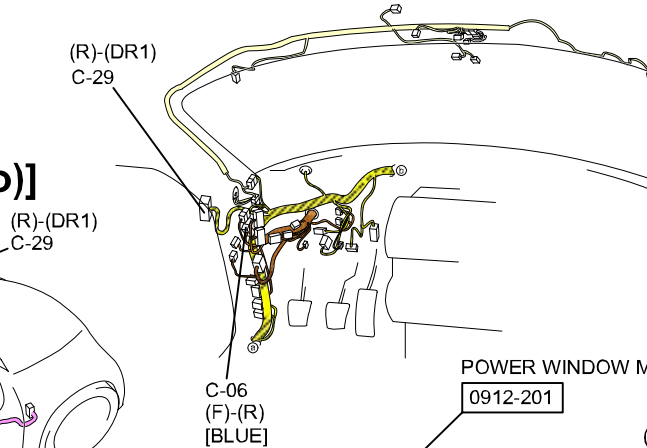

POWER WINDOW MAIN SWITCH
0912-201

C-06
(F)-(R)
[BLUE]

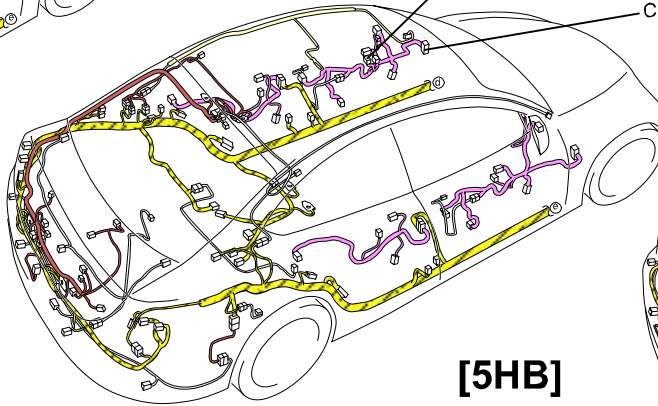

[5HB]

(R)-(DR1)
C-29

POWER WINDOW MAIN SWITCH
0912-201

(R)-(DR1)
C-29

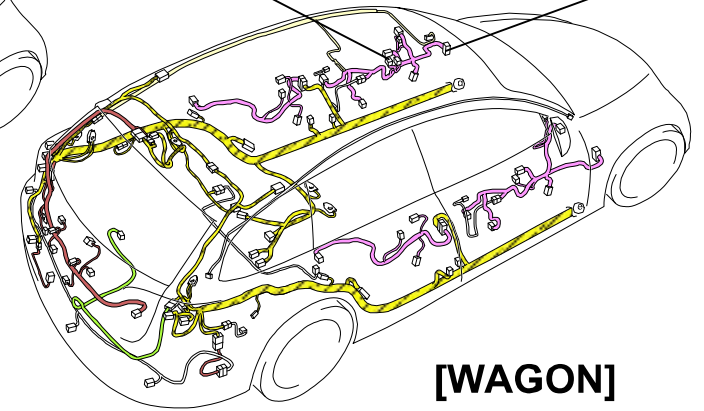

[WAGON]

- : FRONT HARNESS
- : ENGINE HARNESS
- : INJECTION HARNESS
- : REAR HARNESS
- : REAR NO.2 HARNESS
- : REAR NO.3 HARNESS
- : REAR NO.4 HARNESS
- : DOOR HARNESS
- : INTERIOR LIGHT HARNESS
- : INTERIOR LIGHT NO.2 HARNESS
- : FLOOR HARNESS

C-06

FRONT HARNESS-REAR HARNESS

FRONT HARNESS

REAR HARNESS

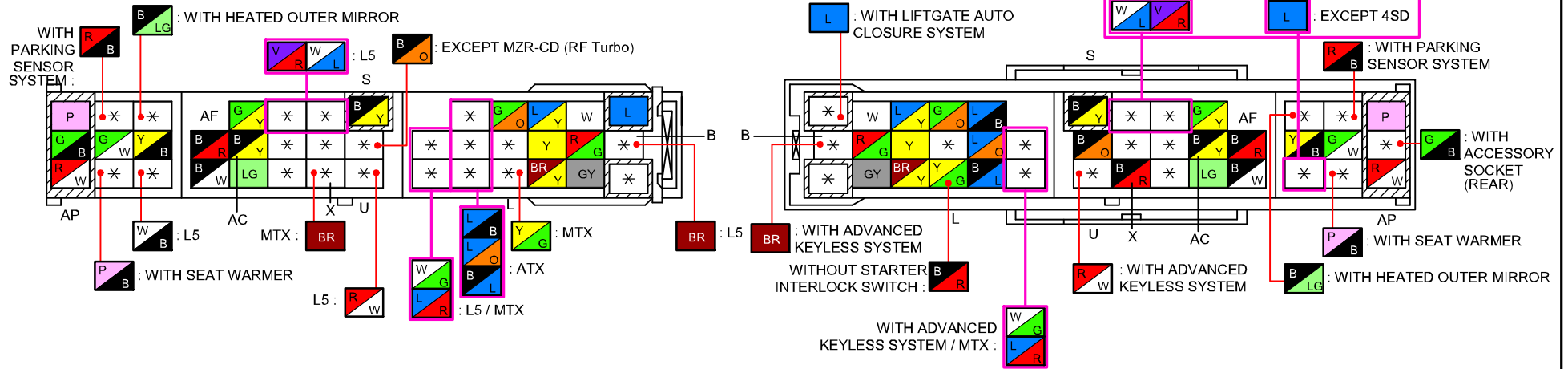

C-29

REAR HARNESS-DOOR NO.1 HARNESS

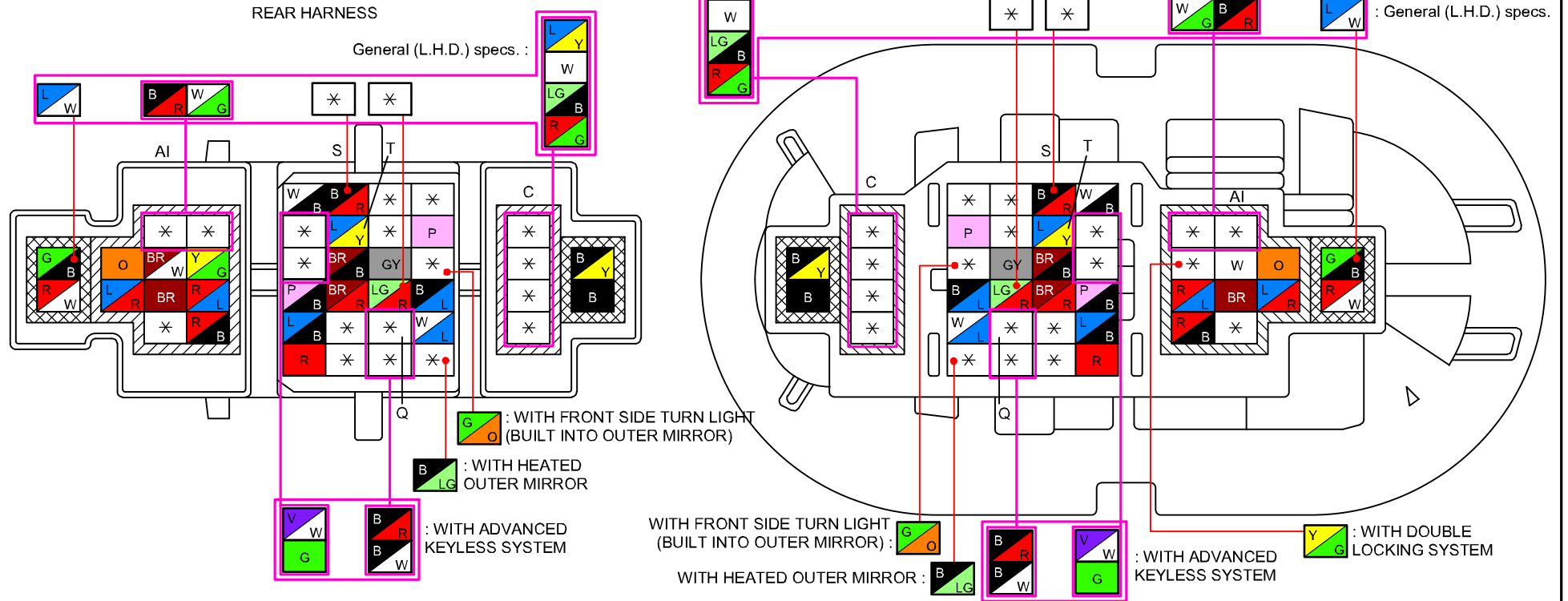

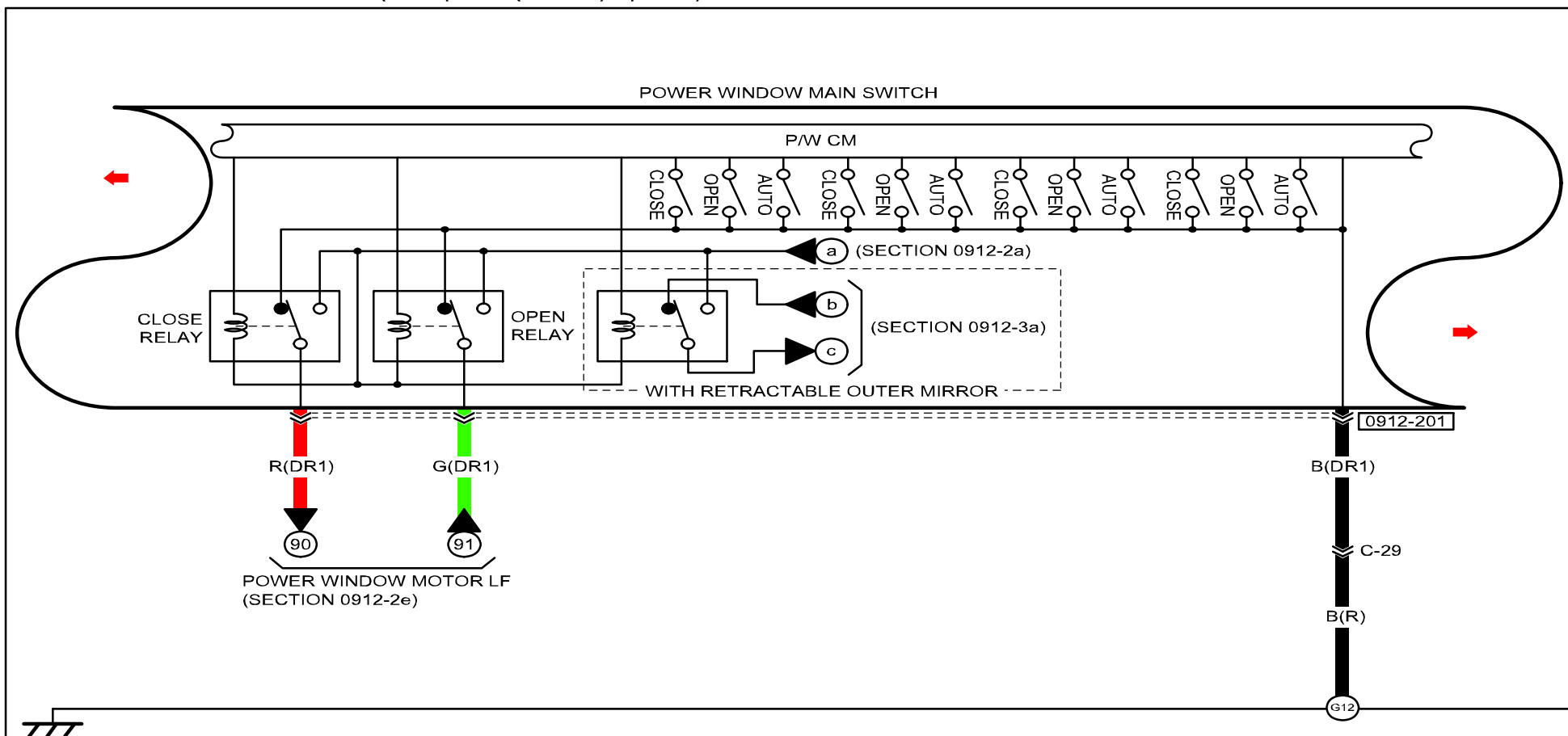









<p>0912-201 POWER WINDOW MAIN SWITCH</p>					

POWER WINDOW SYSTEM (European (L.H.D.) specs.)

0912-2b

-  : FRONT HARNESS
-  : REAR HARNESS
-  : REAR NO.2 HARNESS
-  : REAR NO.3 HARNESS
-  : REAR NO.4 HARNESS
-  : DOOR HARNESS
-  : INTERIOR LIGHT HARNESS
-  : INTERIOR LIGHT NO.2 HARNESS
-  : FLOOR HARNESS

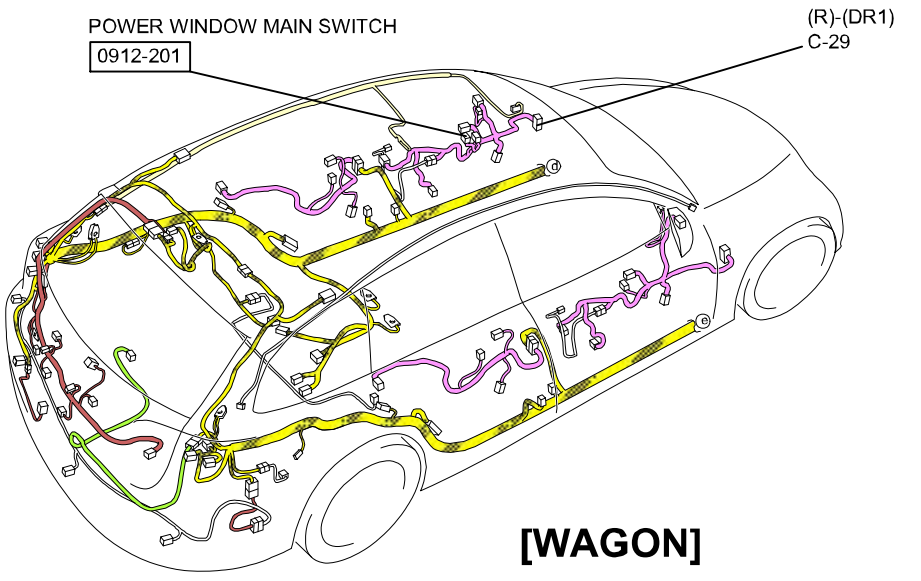
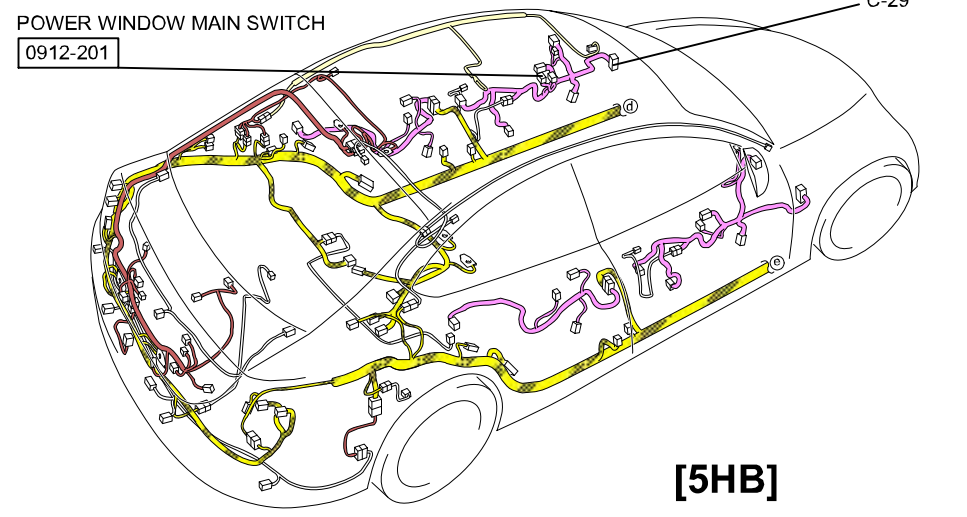
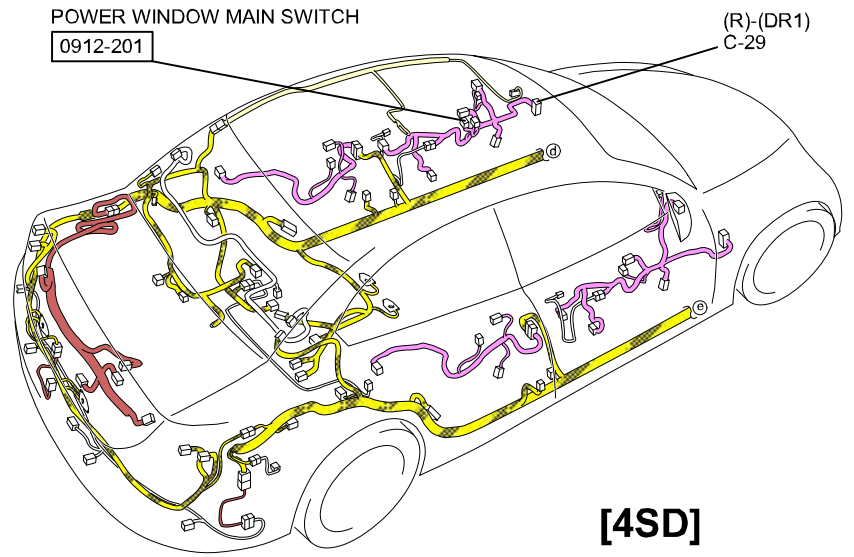
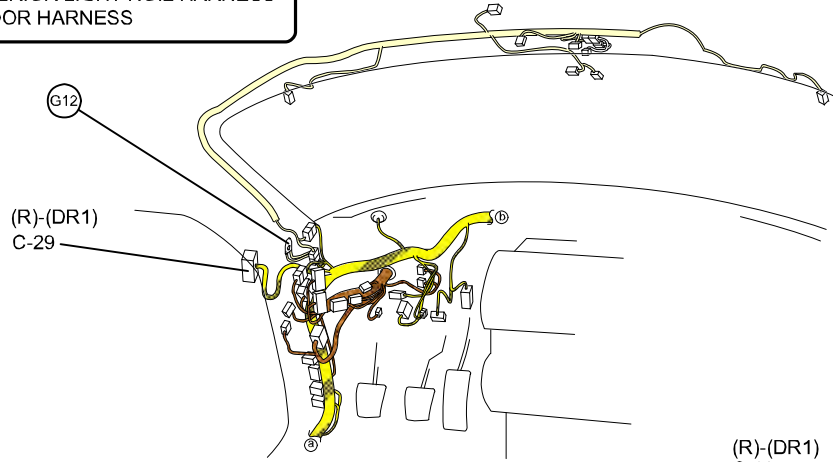

C-29

REAR HARNESS-DOOR NO.1 HARNESS

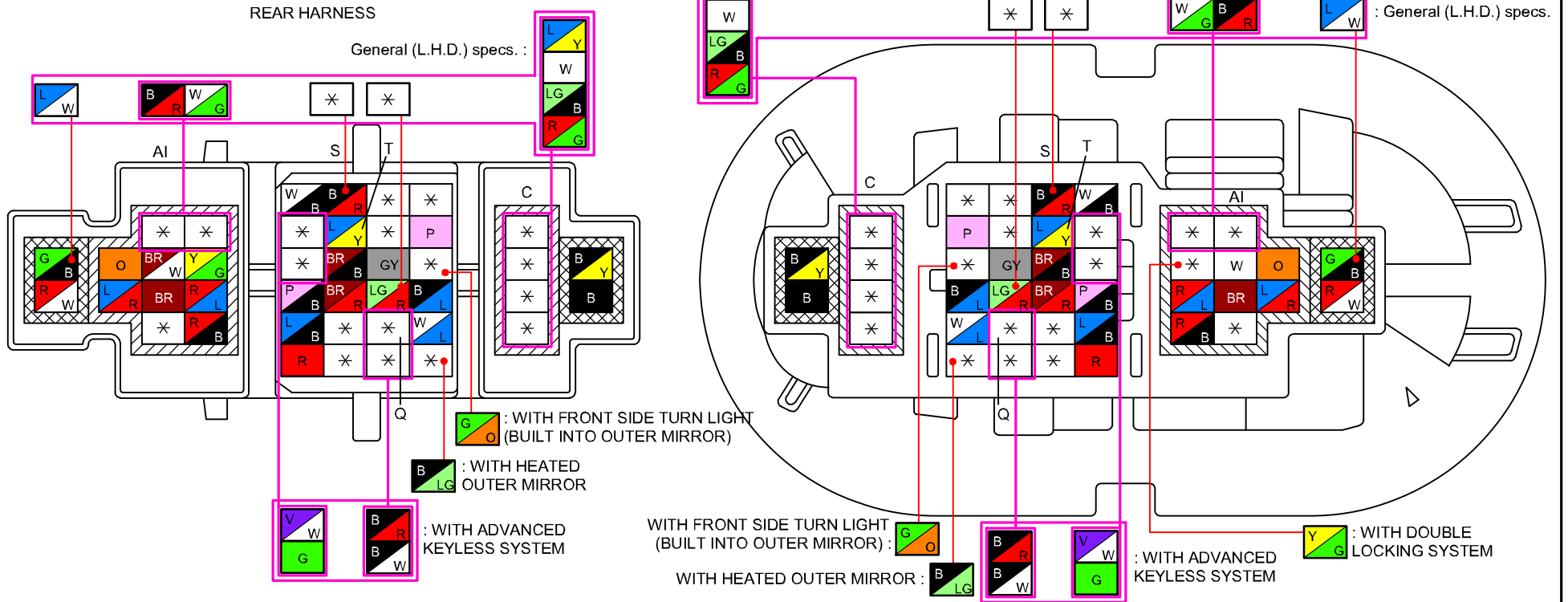

0912-2d 

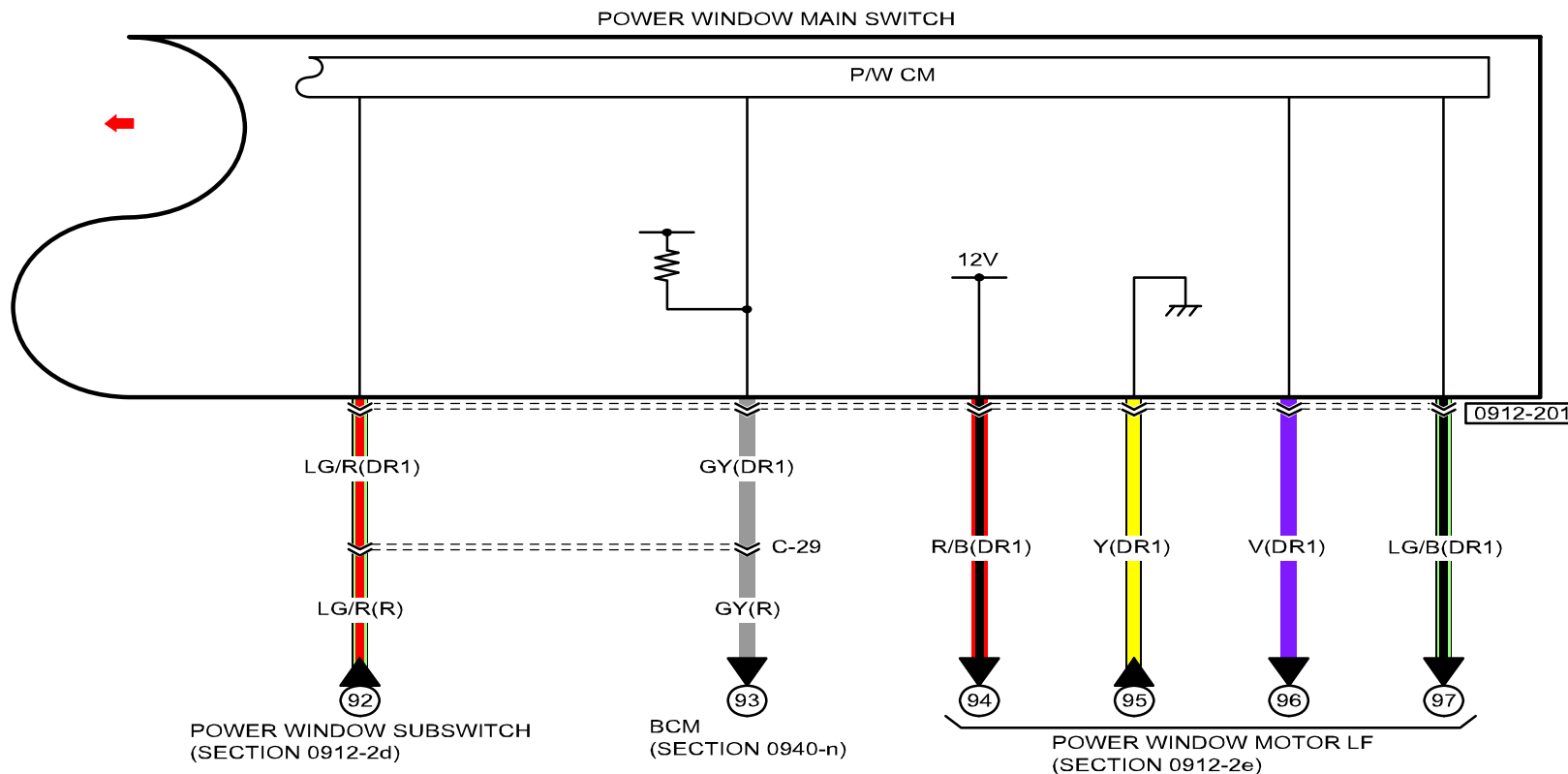



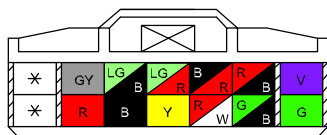





0912-201
POWER WINDOW MAIN SWITCH



POWER WINDOW SYSTEM (European (L.H.D.) specs.)

0912-2c

-  : FRONT HARNESS
-  : REAR HARNESS
-  : REAR NO.2 HARNESS
-  : REAR NO.3 HARNESS
-  : REAR NO.4 HARNESS
-  : DOOR HARNESS
-  : INTERIOR LIGHT HARNESS
-  : INTERIOR LIGHT NO.2 HARNESS
-  : FLOOR HARNESS

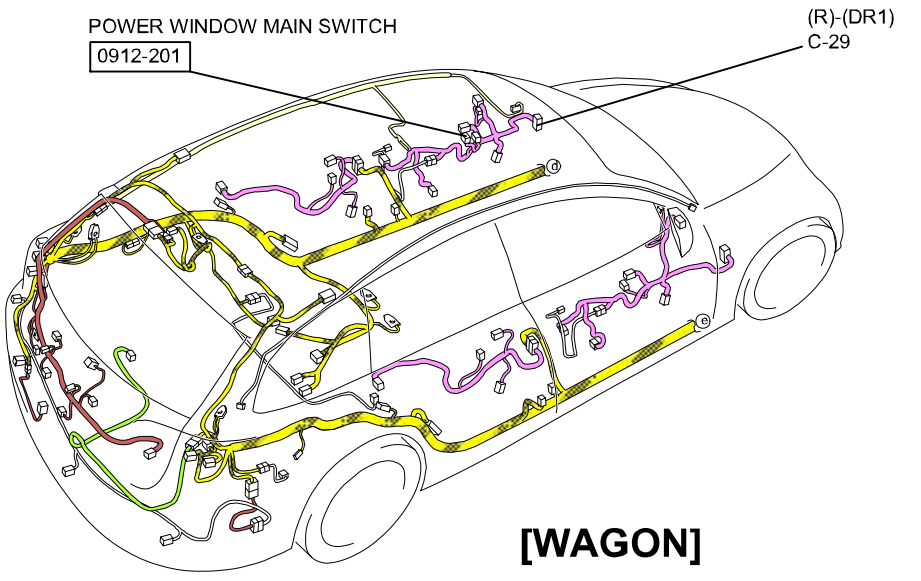
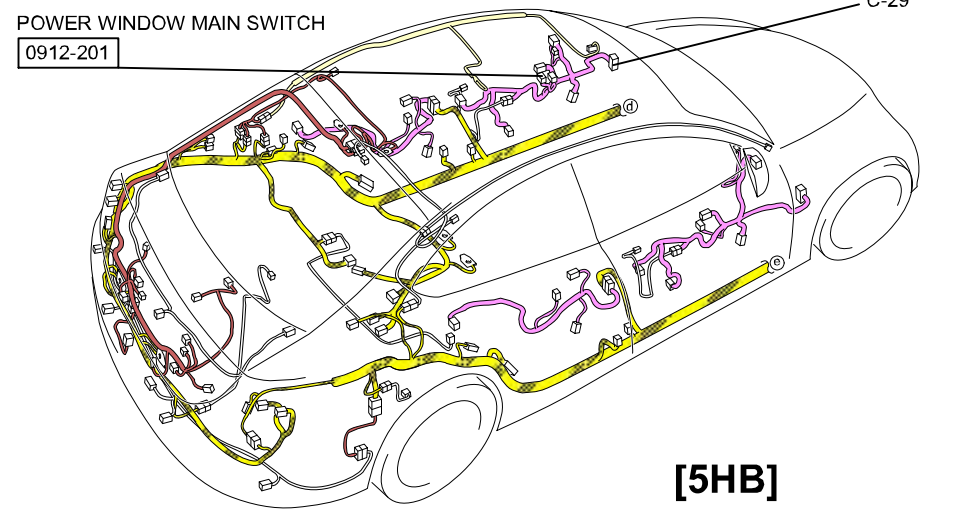
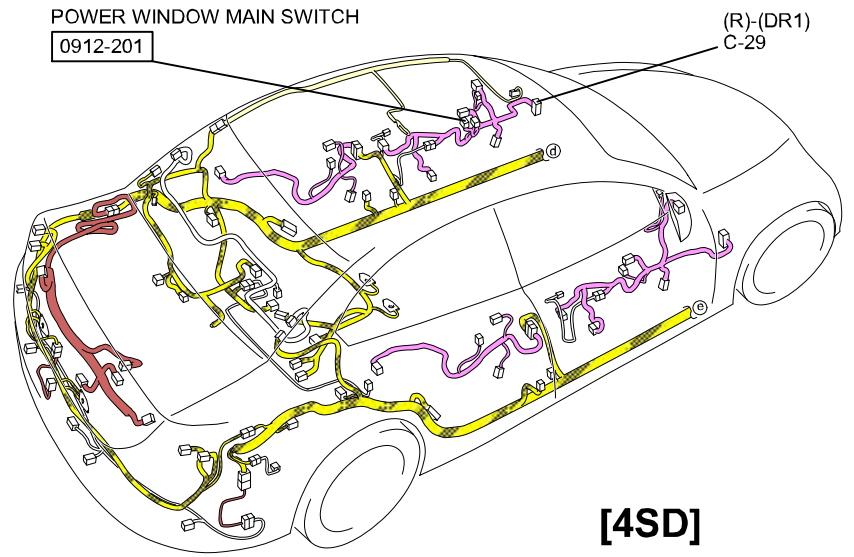
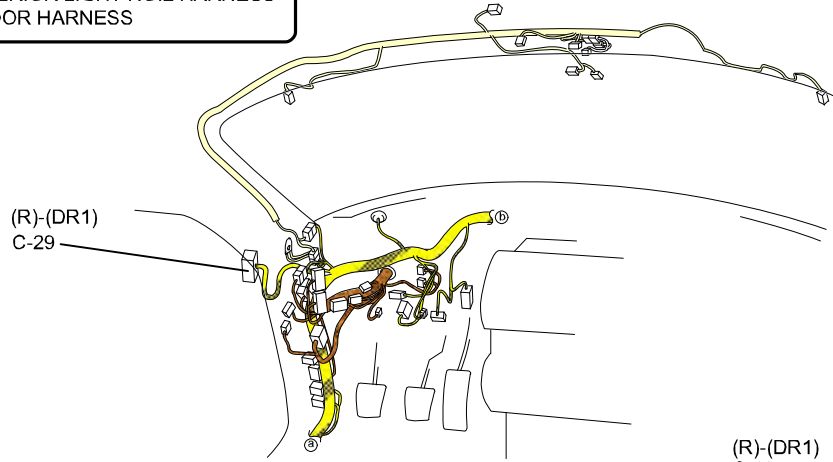

C-29

REAR HARNESS-DOOR NO.1 HARNESS

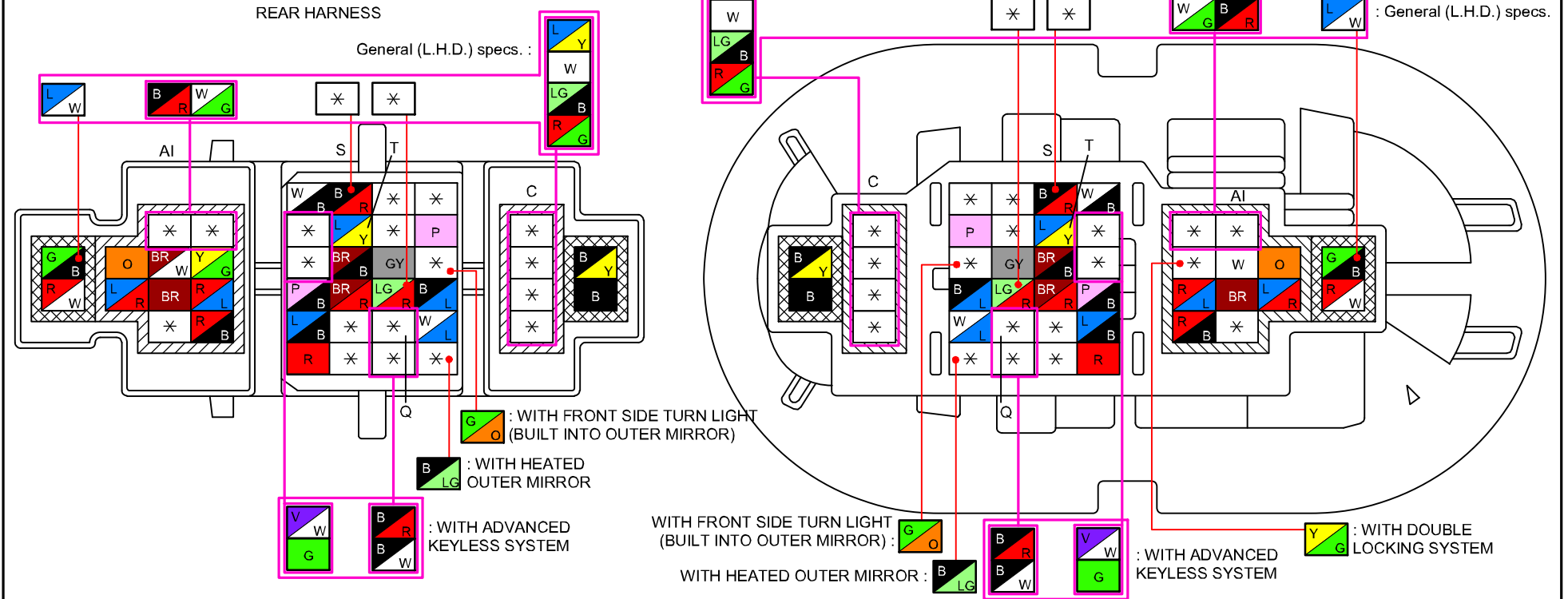

POWER WINDOW SYSTEM (European (L.H.D.) specs.)

0912-2d

- : INSTRUMENT PANEL HARNESS
- : REAR HARNESS
- : REAR NO.2 HARNESS
- : REAR NO.3 HARNESS
- : REAR NO.4 HARNESS
- : REAR NO.5 HARNESS
- : DOOR HARNESS
- : INTERIOR LIGHT HARNESS
- : FLOOR HARNESS

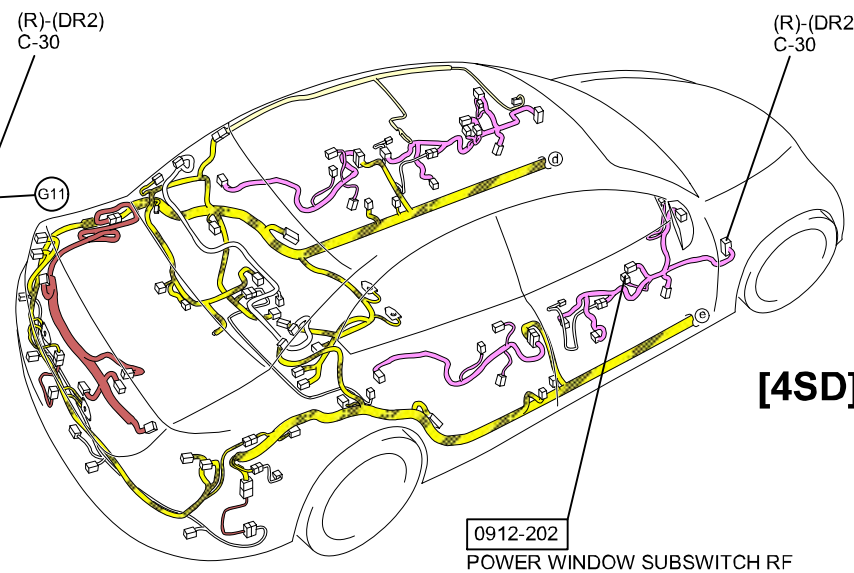
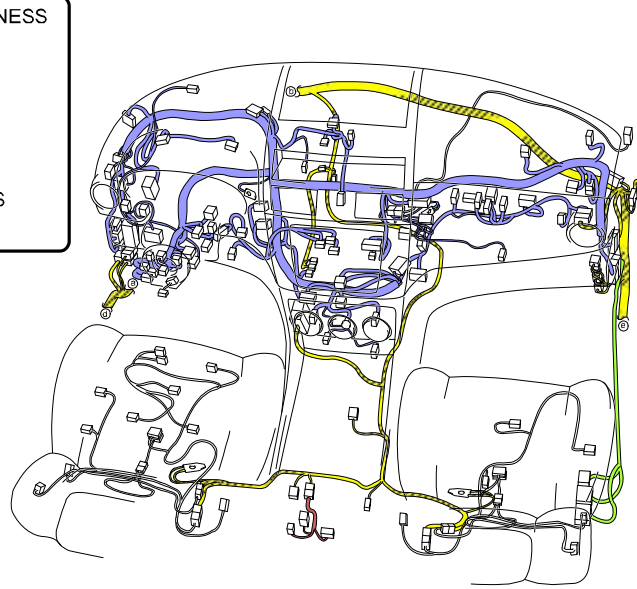

[4SD]

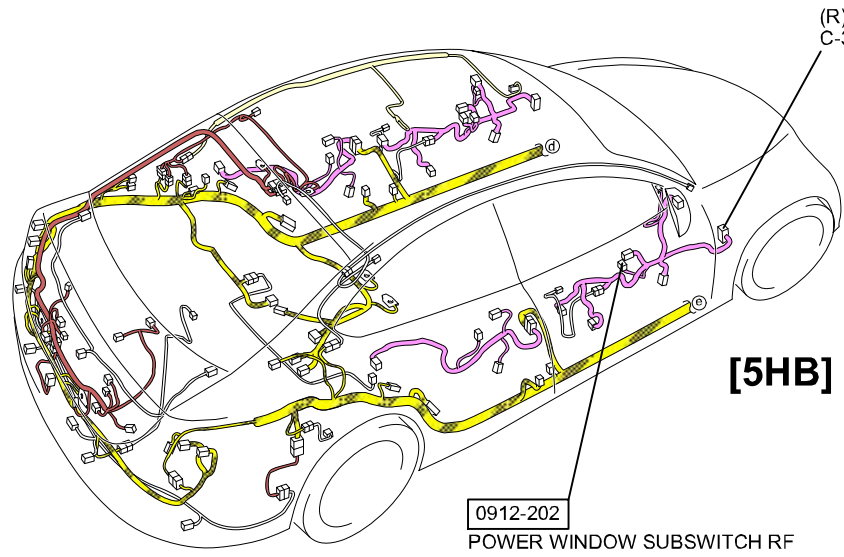

[5HB]

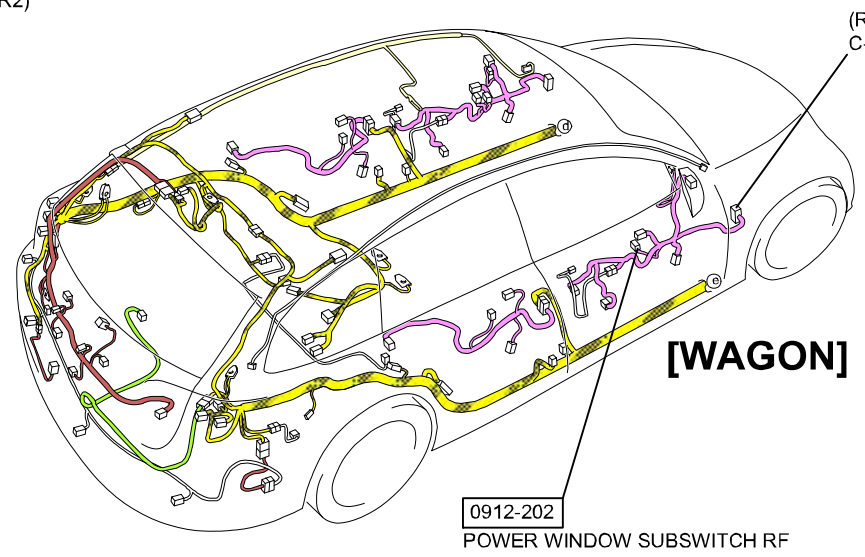

[WAGON]

C-30
REAR HARNESS-DOOR NO.2 HARNESS

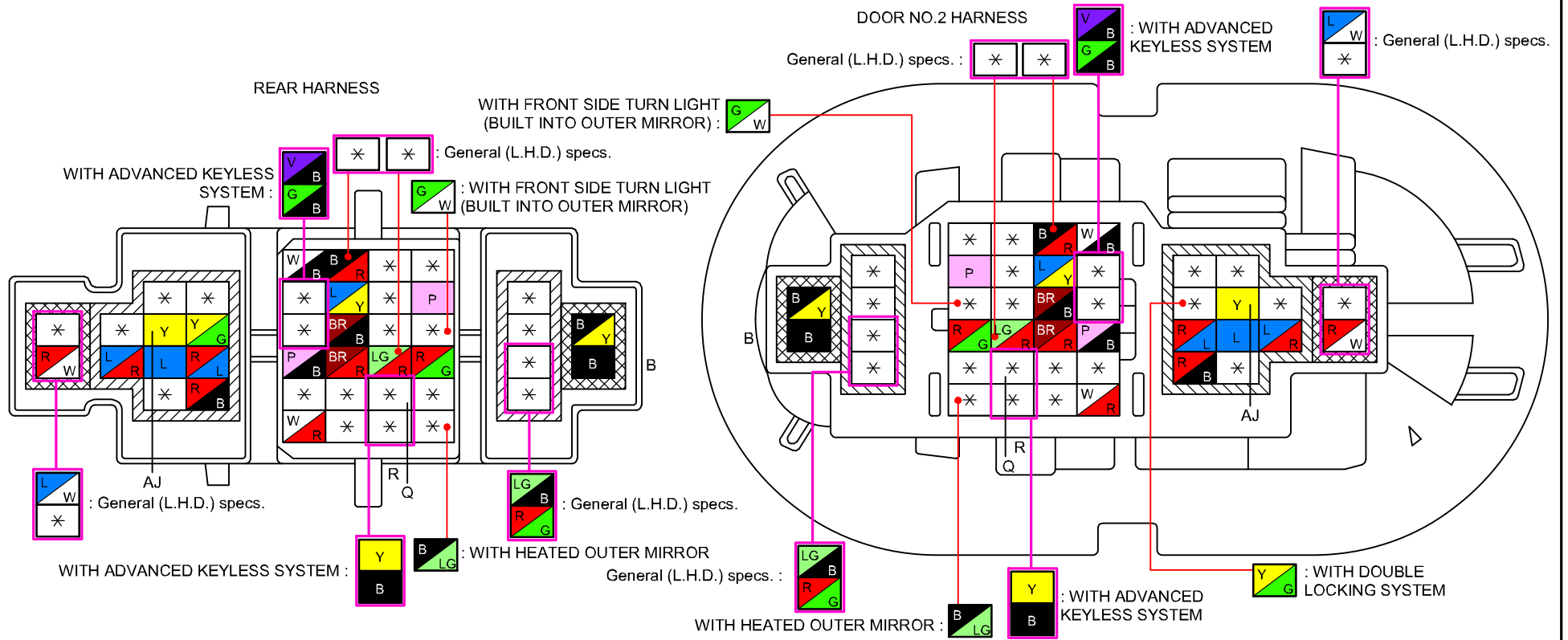

← 0912-2d

→ 0912-2f

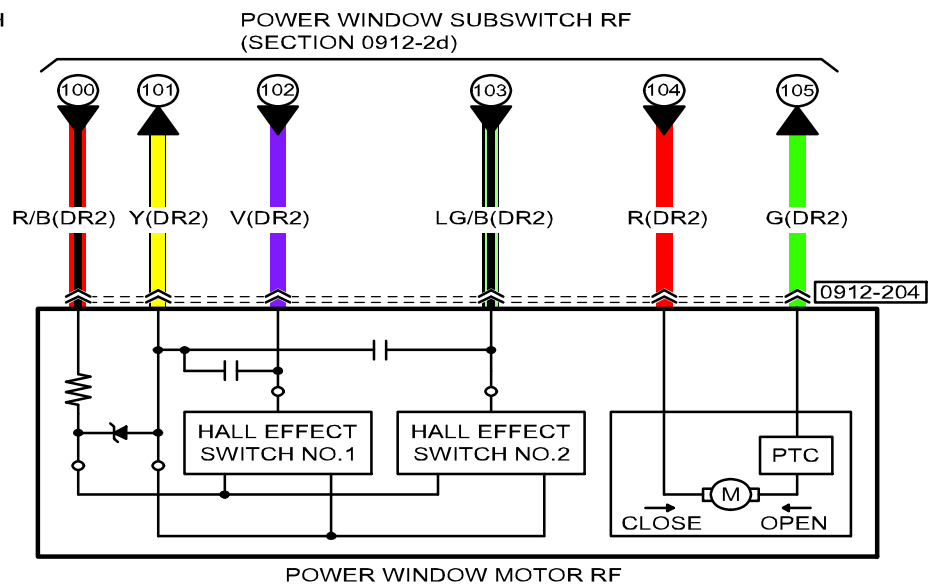
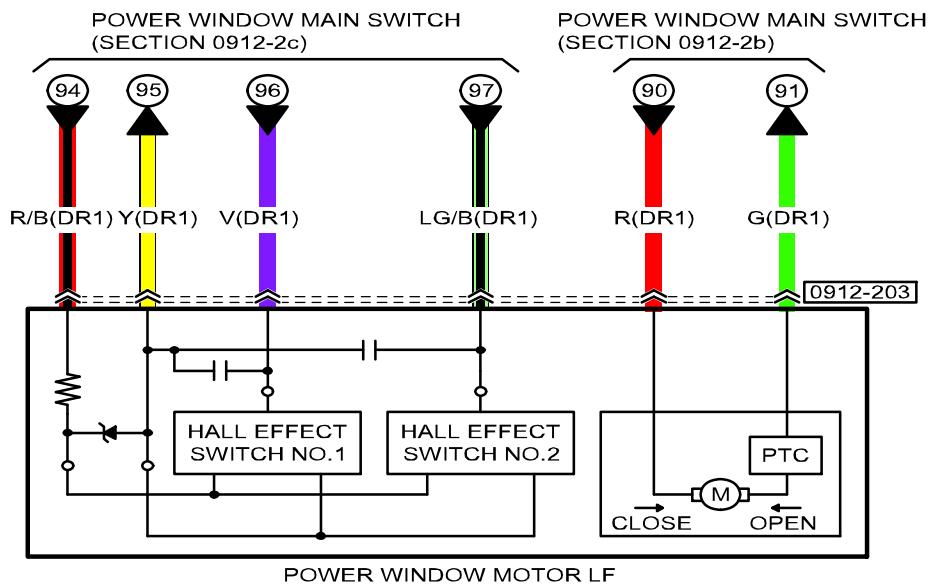

0912-203
POWER WINDOW MOTOR LF

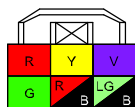

0912-204
POWER WINDOW MOTOR RF

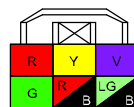

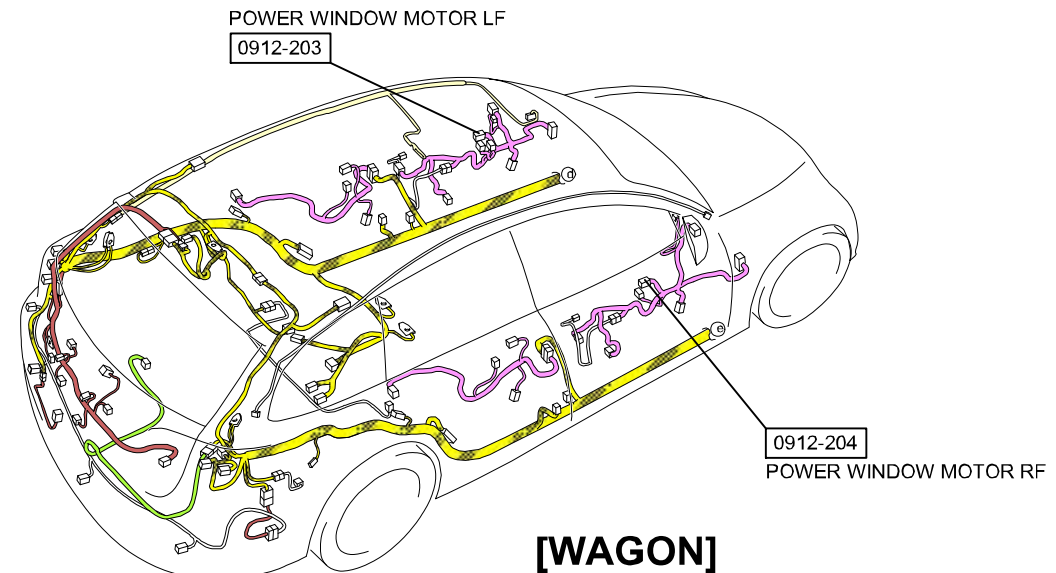
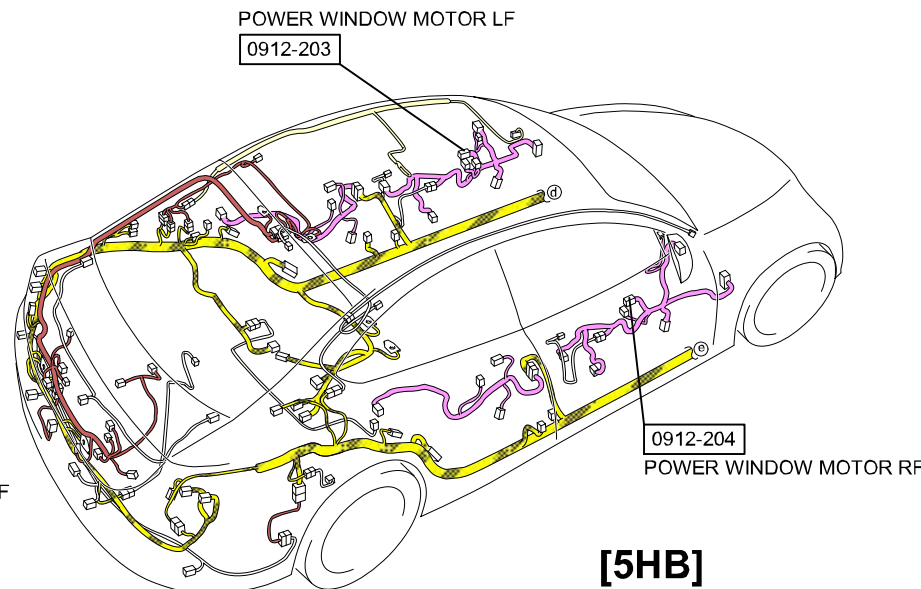
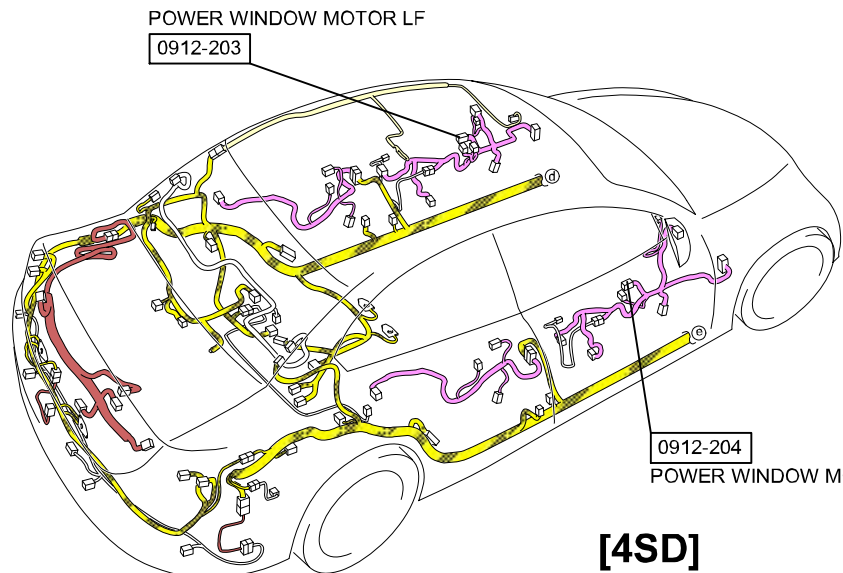

- : REAR HARNESS
- : REAR NO.2 HARNESS
REAR NO.3 HARNESS
REAR NO.4 HARNESS
- : DOOR HARNESS
- : INTERIOR LIGHT HARNESS
- : FLOOR HARNESS

POWER WINDOW SYSTEM (European (L.H.D.) specs.)

0912-2f

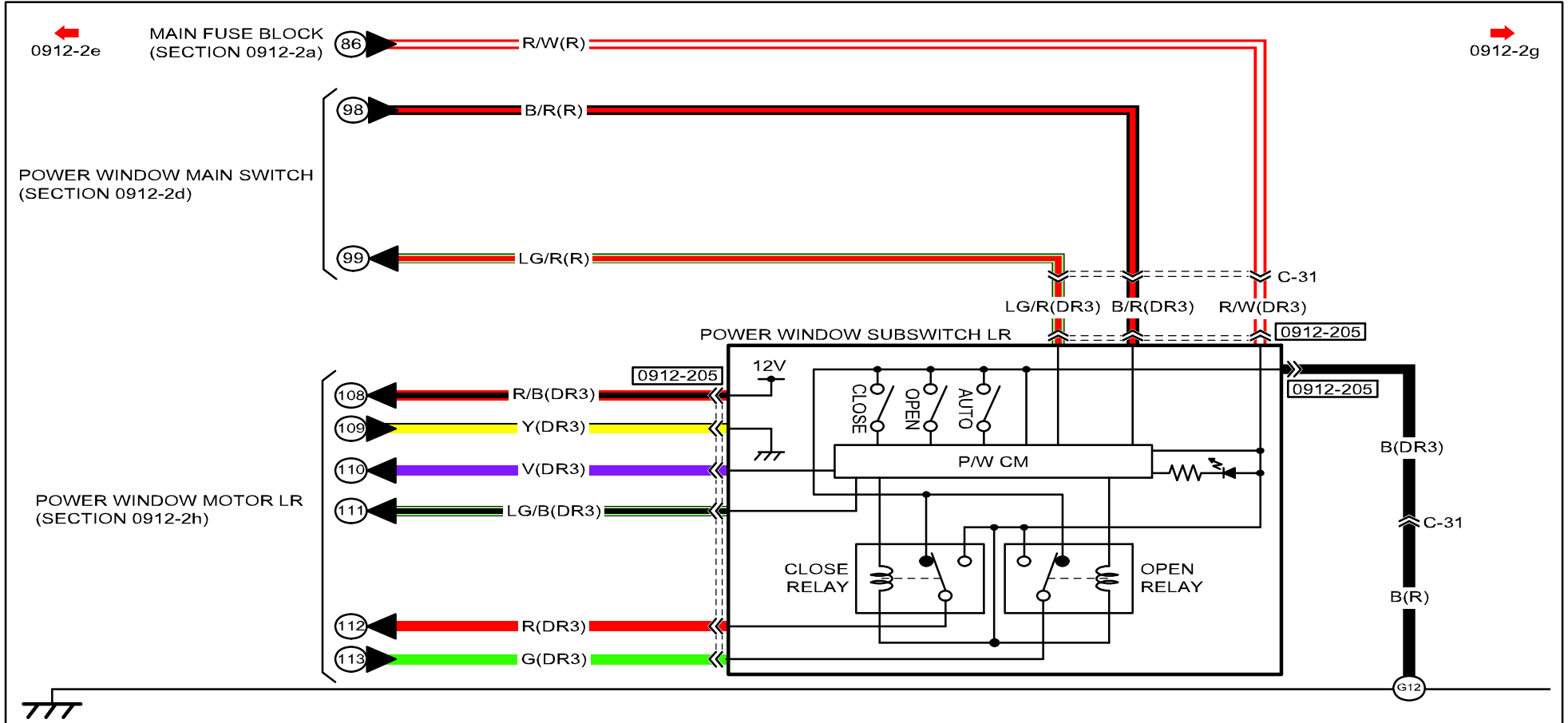



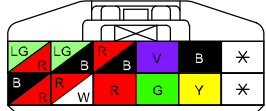





0912-205 POWER WINDOW SUBSWITCH LR



POWER WINDOW SYSTEM (European (L.H.D.) specs.)

0912-2f

-  : FRONT HARNESS
-  : REAR HARNESS
-  : REAR NO.2 HARNESS
-  : REAR NO.3 HARNESS
-  : REAR NO.4 HARNESS
-  : DOOR HARNESS
-  : INTERIOR LIGHT HARNESS
-  : INTERIOR LIGHT NO.2 HARNESS
-  : FLOOR HARNESS

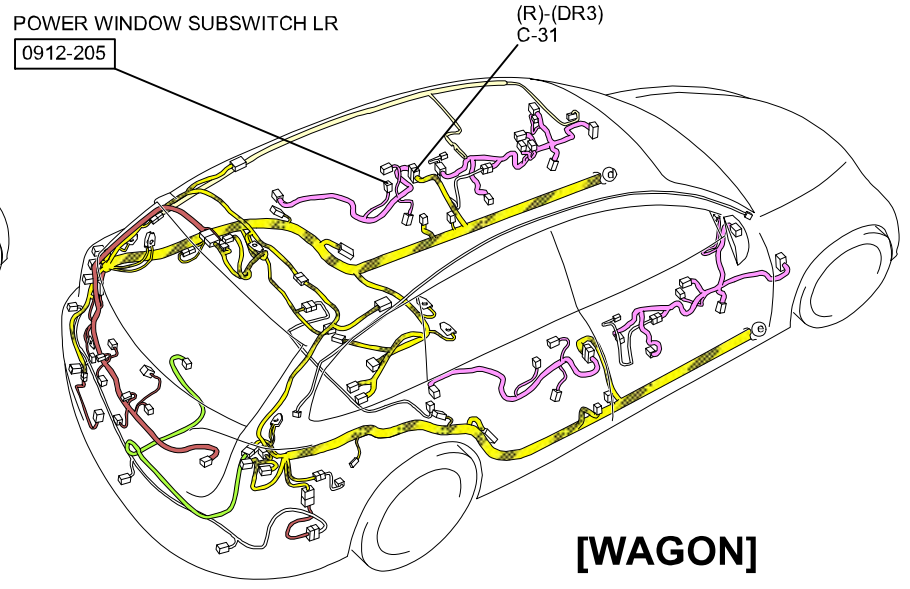
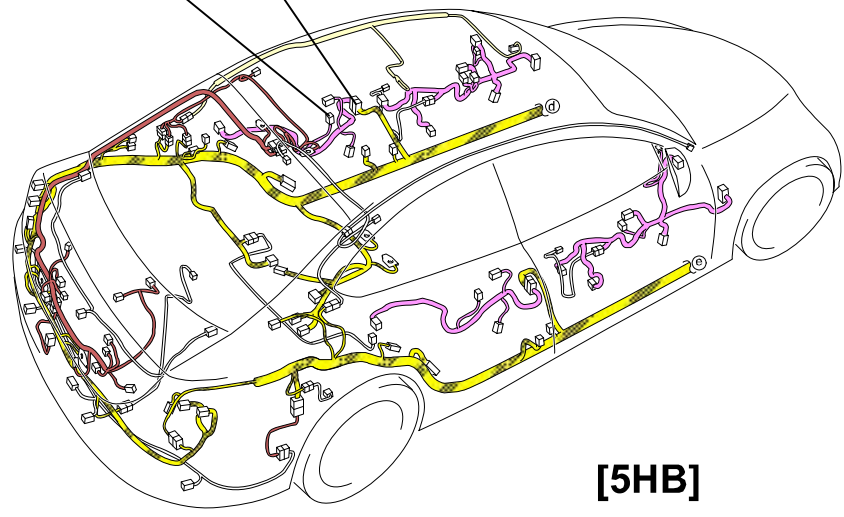
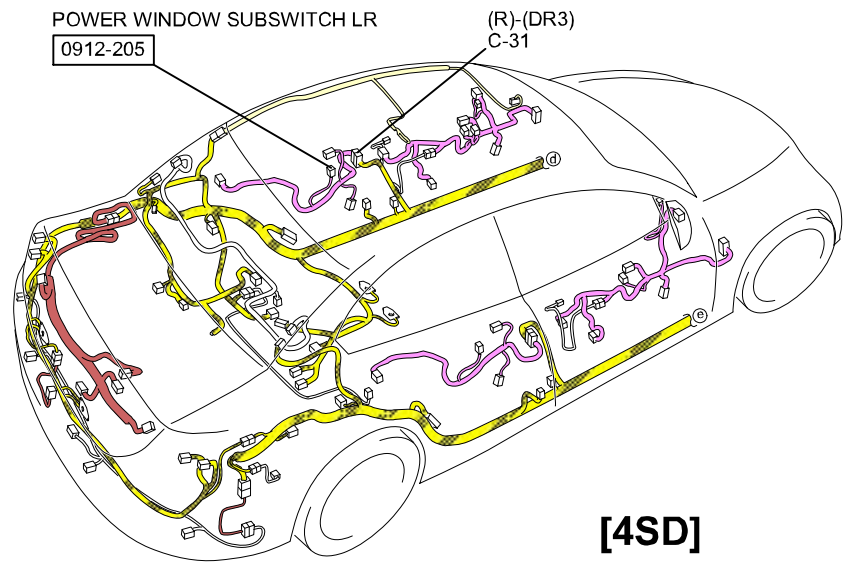
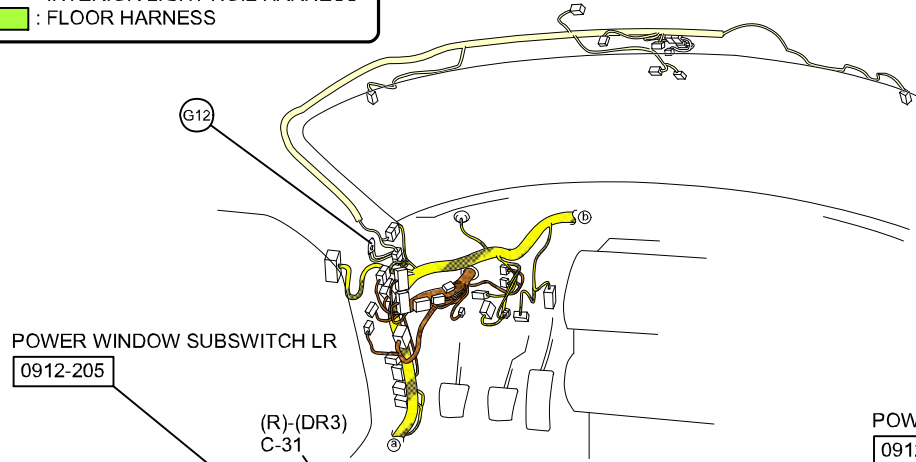

C-31

REAR HARNESS-DOOR NO.3 HARNESS

REAR HARNESS

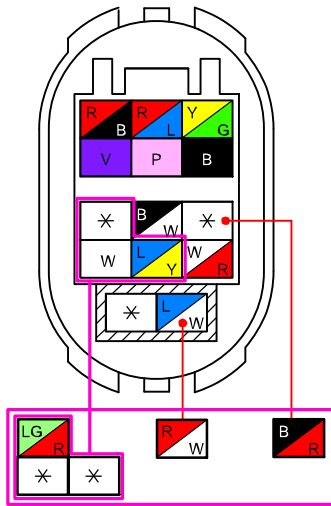

: European (L.H.D.) specs.

DOOR NO.3 HARNESS

Y : WITH DOUBLE LOCKING SYSTEM
G

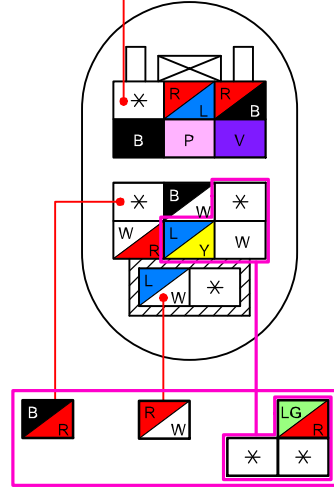

: European (L.H.D.) specs.

POWER WINDOW SYSTEM (European (L.H.D.) specs.)

0912-2g

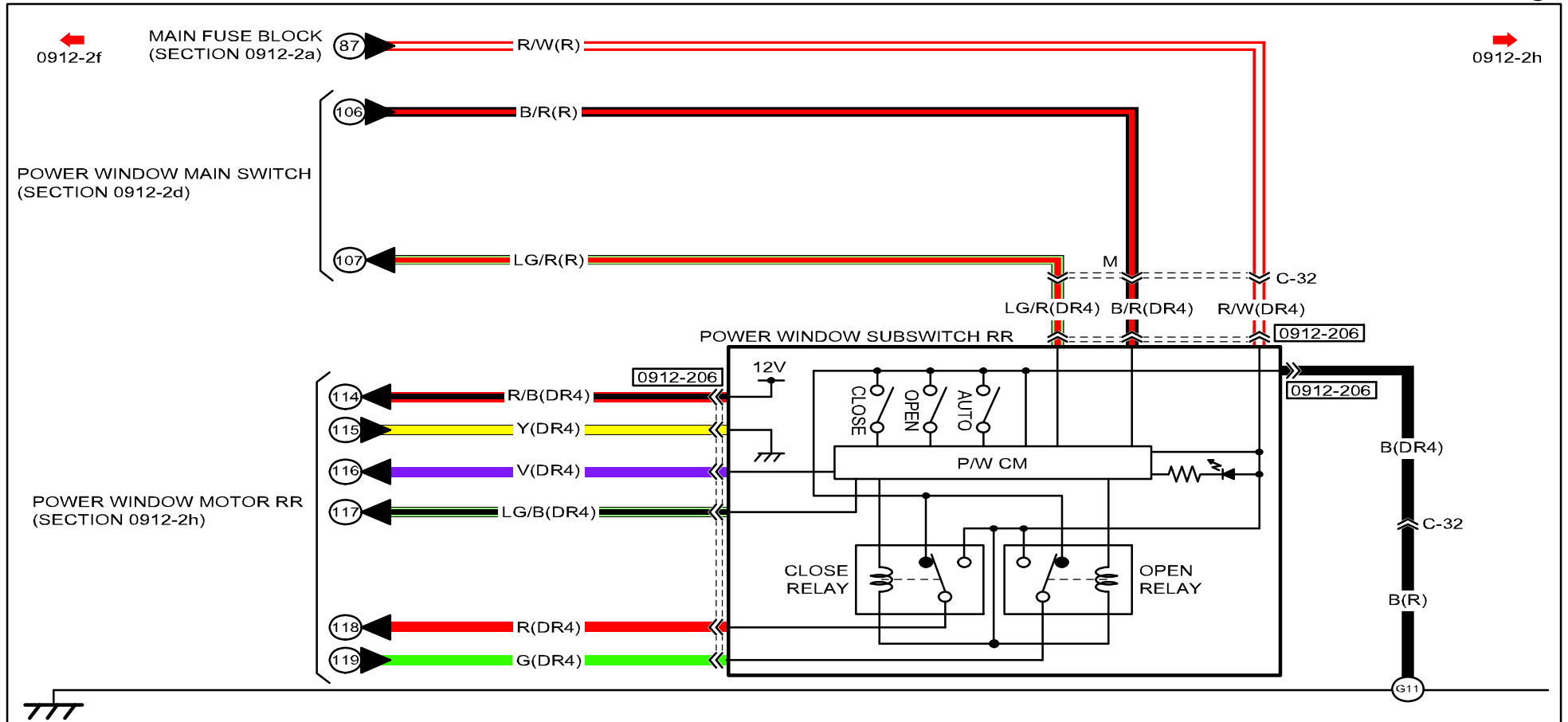

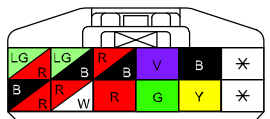
<p>0912-206 POWER WINDOW SUBSWITCH RR</p> 					

POWER WINDOW SYSTEM (European (L.H.D.) specs.)

0912-2g

- : INSTRUMENT PANEL HARNESS
- : REAR HARNESS
- : REAR NO.2 HARNESS
- : REAR NO.3 HARNESS
- : REAR NO.4 HARNESS
- : REAR NO.5 HARNESS
- : DOOR HARNESS
- : INTERIOR LIGHT HARNESS
- : FLOOR HARNESS

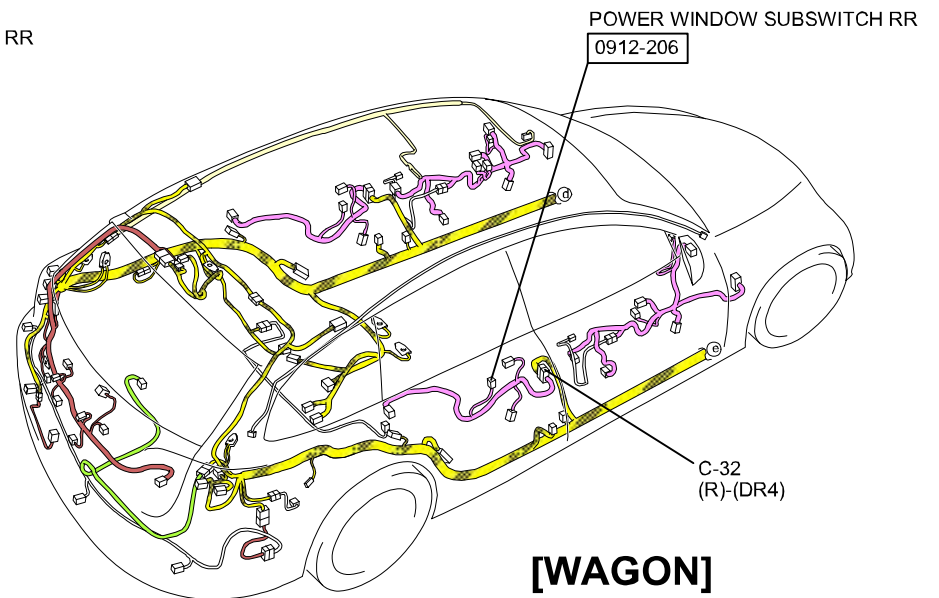
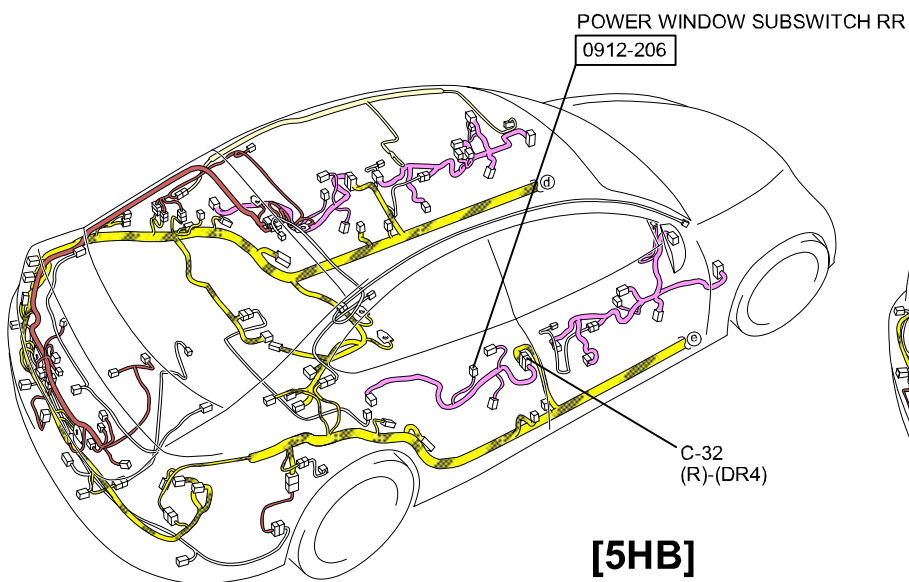
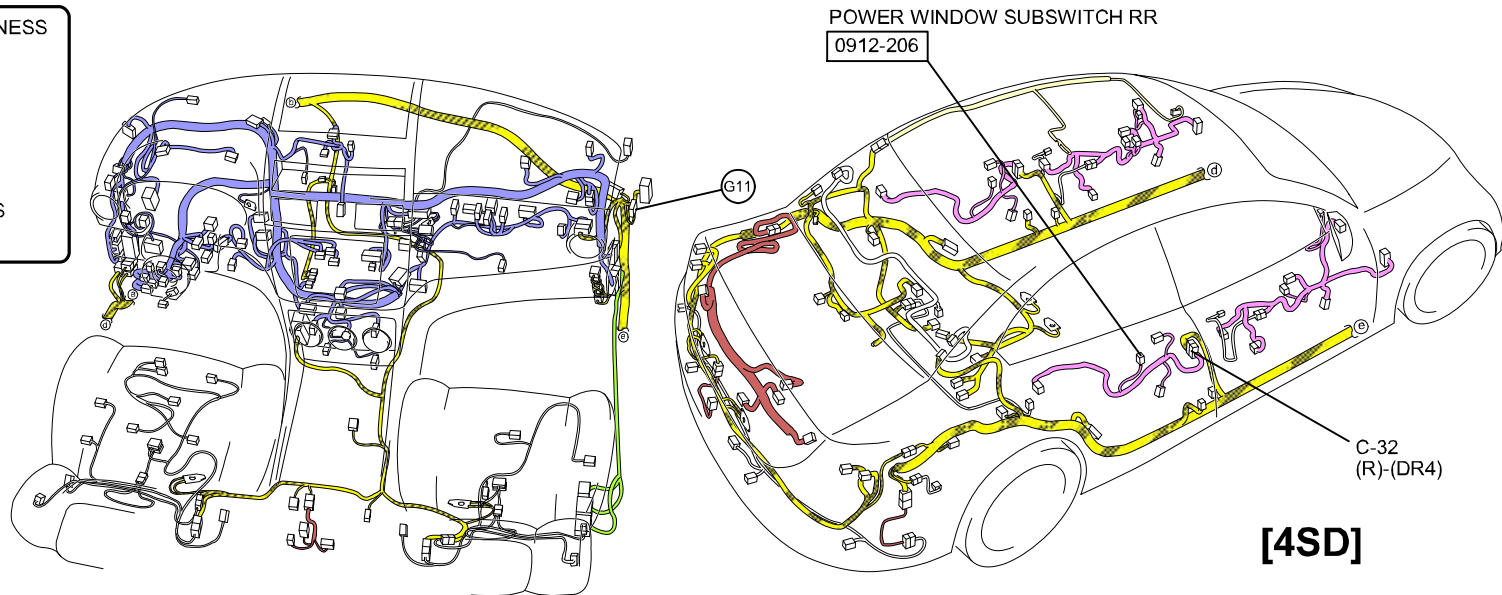

C-32

REAR HARNESS-DOOR NO.4 HARNESS

REAR HARNESS

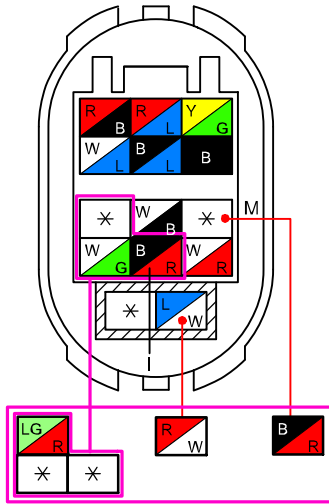

: European (L.H.D.) specs.

DOOR NO.4 HARNESS

Y : WITH DOUBLE LOCKING SYSTEM
G

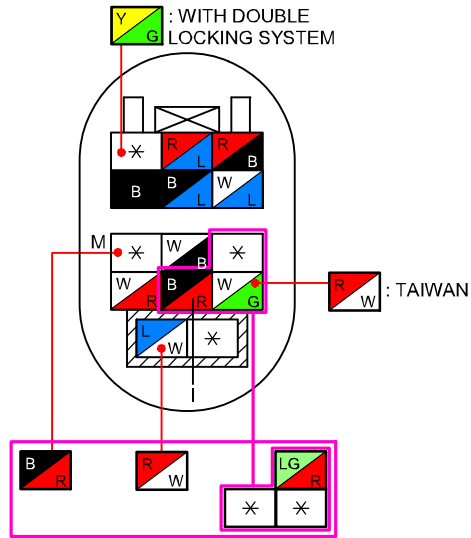

: European (L.H.D.) specs.

0912-2g

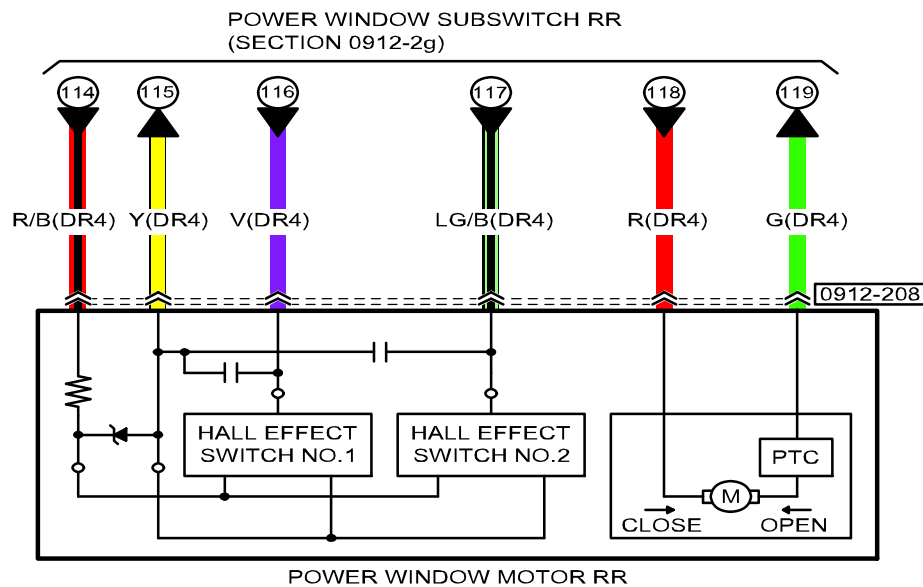
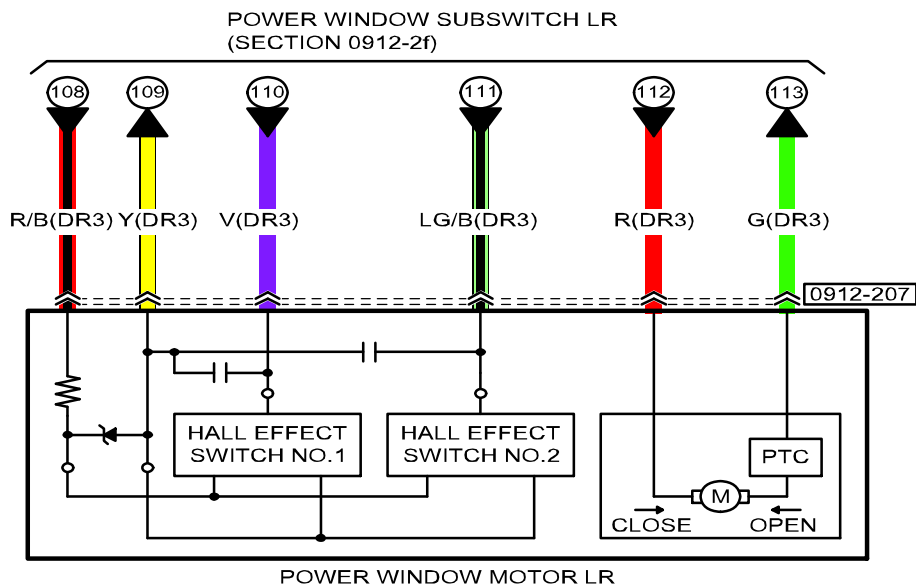

0912-207
POWER WINDOW MOTOR LR

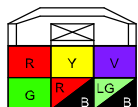

0912-208
POWER WINDOW MOTOR RR

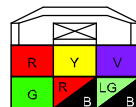

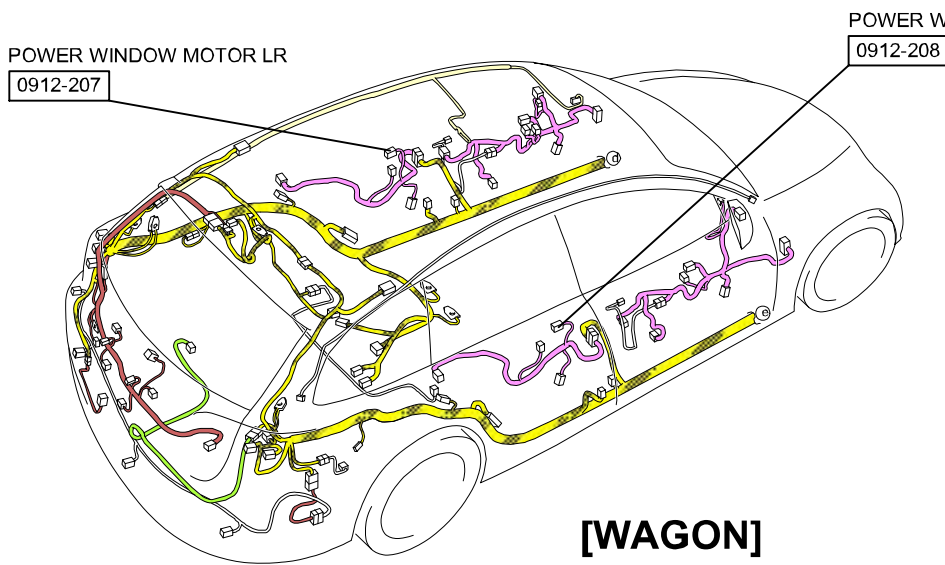
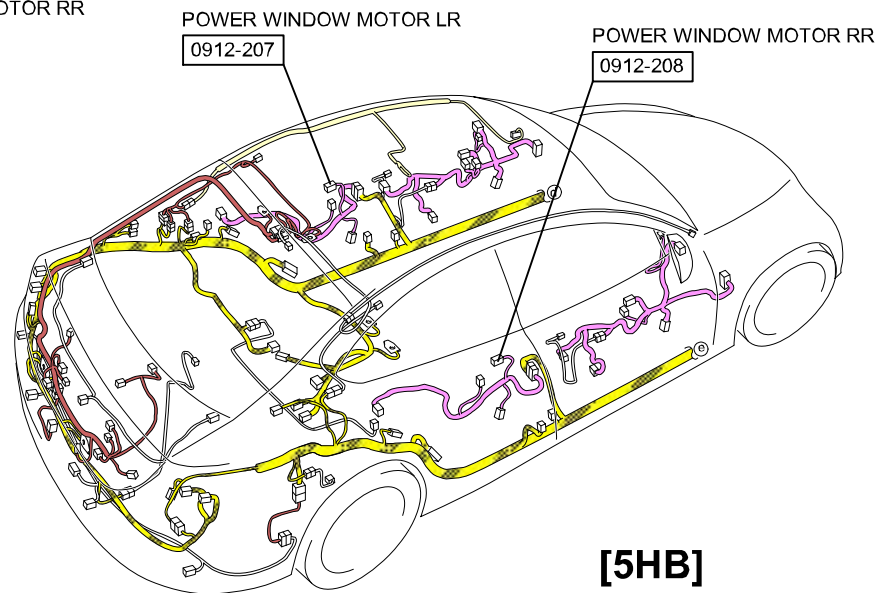
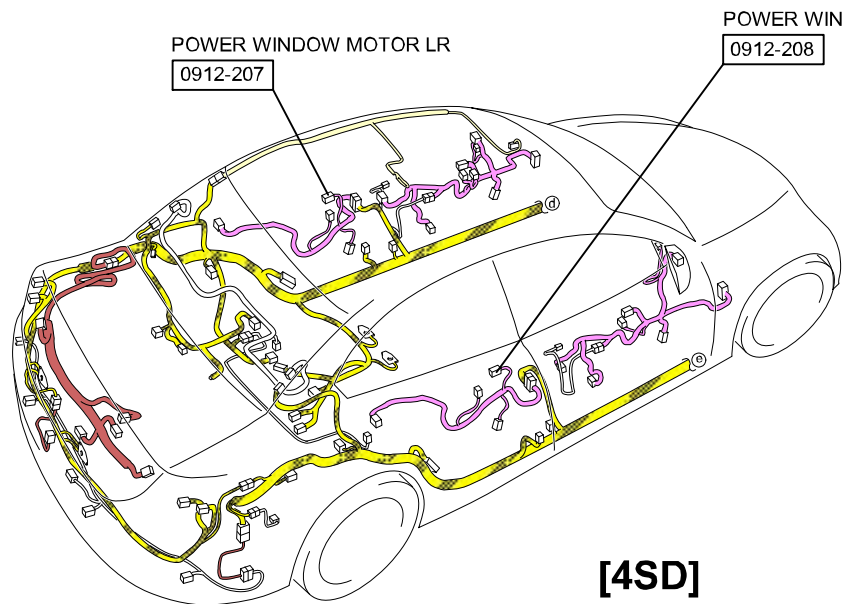

- : REAR HARNESS
- : REAR NO.2 HARNESS
REAR NO.3 HARNESS
REAR NO.4 HARNESS
- : DOOR HARNESS
- : INTERIOR LIGHT HARNESS
- : FLOOR HARNESS

POWER OUTER MIRROR / RETRACTABLE OUTER MIRROR

0912-3a

IGNITION SWITCH (ACC) ← @1
 (SECTION 0921-1b)
 ACC RELAY ← @2
 (SECTION 0921-2b)

#1 : WITHOUT RETRACTABLE OUTER MIRROR
 #2 : WITH RETRACTABLE OUTER MIRROR
 #4 : European (L.H.D.) specs.

@1 : WITHOUT ADVANCED KEYLESS SYSTEM
 @2 : WITH ADVANCED KEYLESS SYSTEM
 &4 : General (L.H.D.) specs.

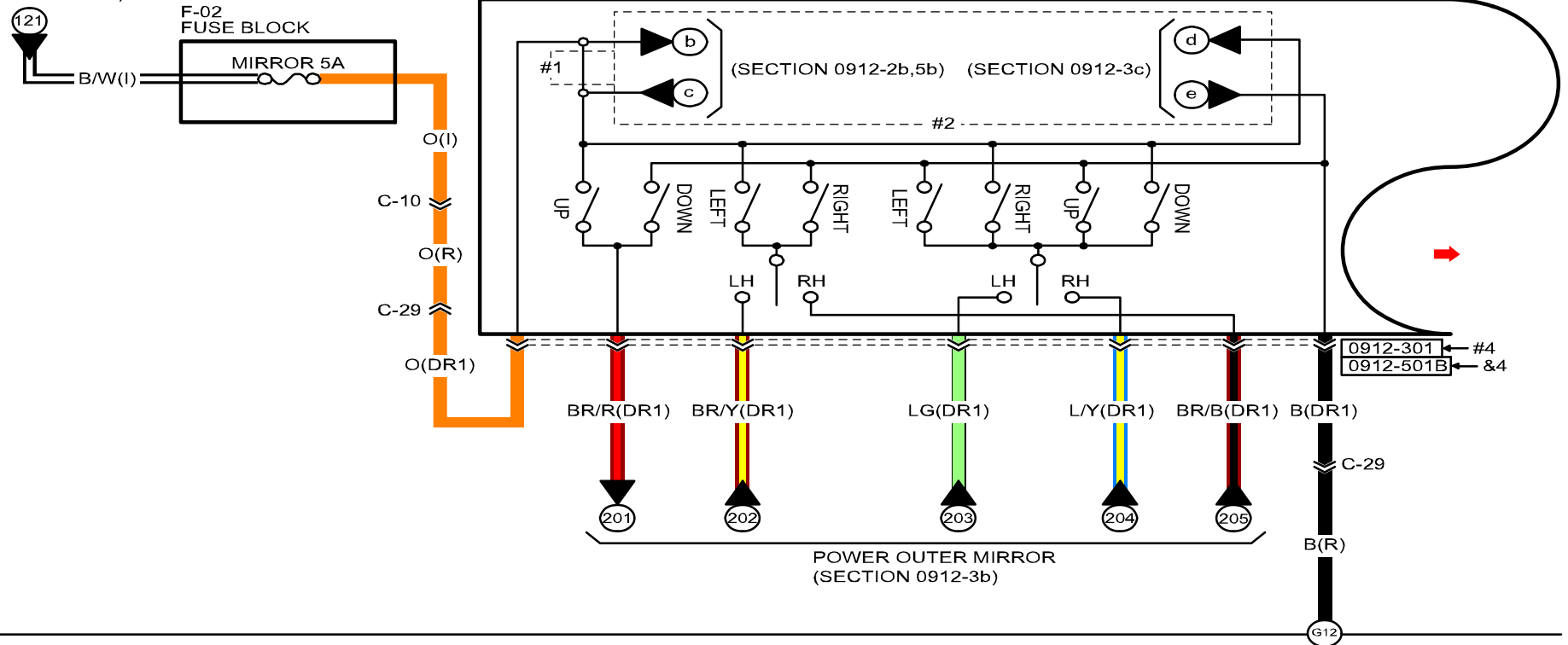

0912-301
 POWER OUTER MIRROR SWITCH /
 RETRACTABLE OUTER MIRROR SWITCH

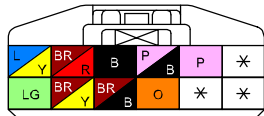

0912-501B
 POWER OUTER MIRROR SWITCH /
 RETRACTABLE OUTER MIRROR SWITCH /
 POWER WINDOW MAIN SWITCH

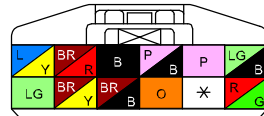

--	--	--	--	--	--

POWER OUTER MIRROR / RETRACTABLE OUTER MIRROR

0912-3a

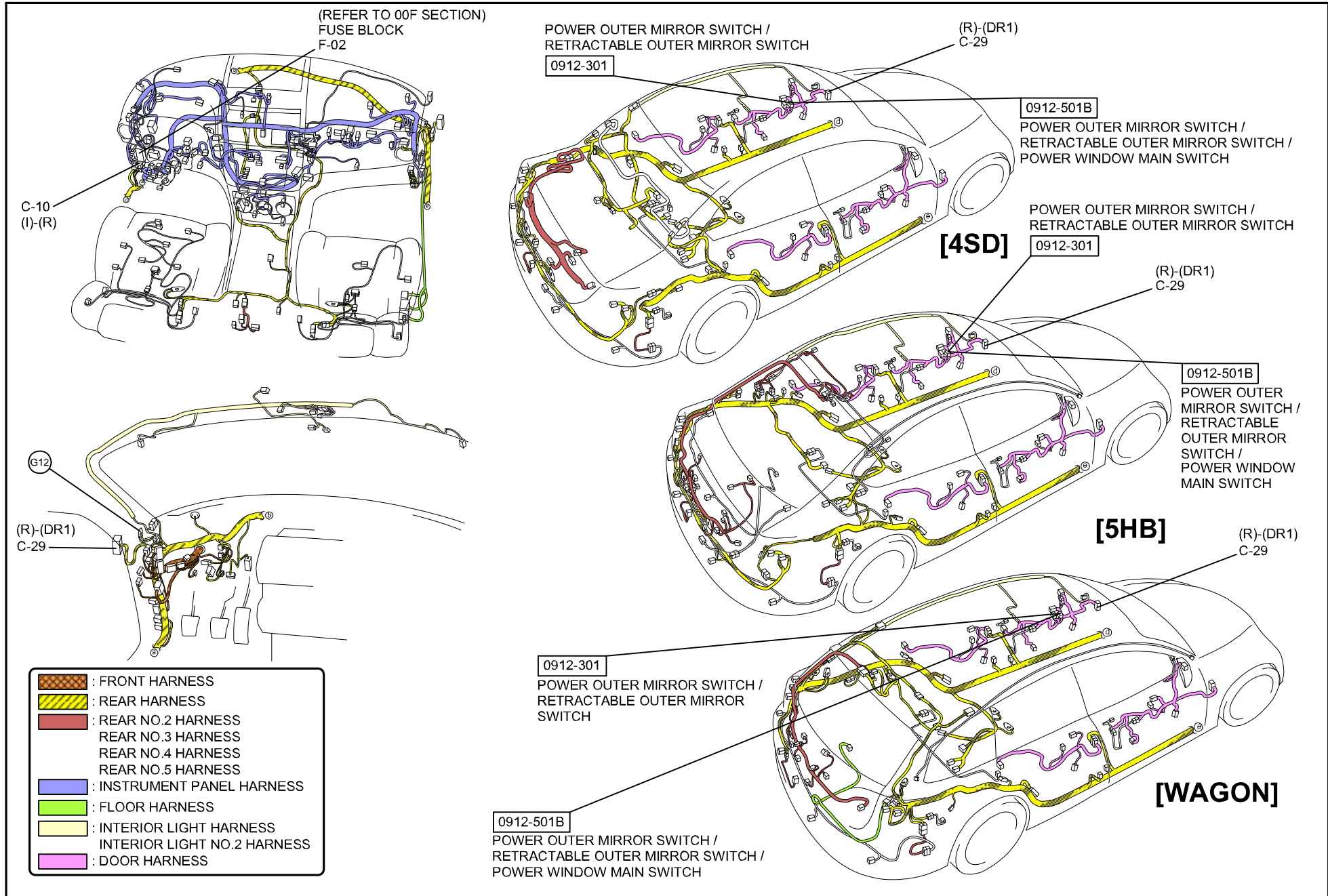

C-10

INSTRUMENT PANEL HARNESS-REAR HARNESS

INSTRUMENT PANEL HARNESS

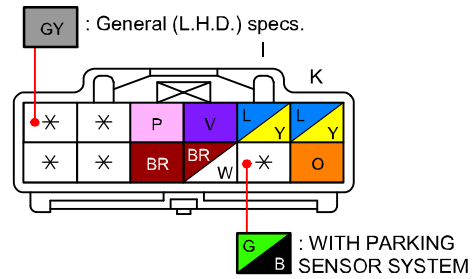

REAR HARNESS

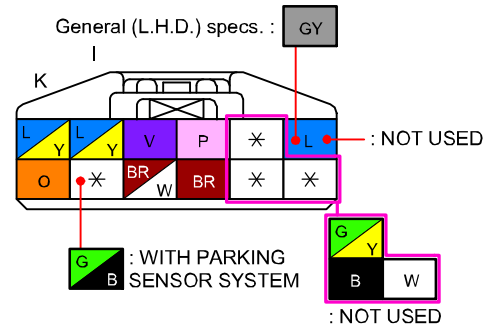

POWER OUTER MIRROR / RETRACTABLE OUTER MIRROR

0912-3a

C-29

REAR HARNESS-DOOR NO.1 HARNESS

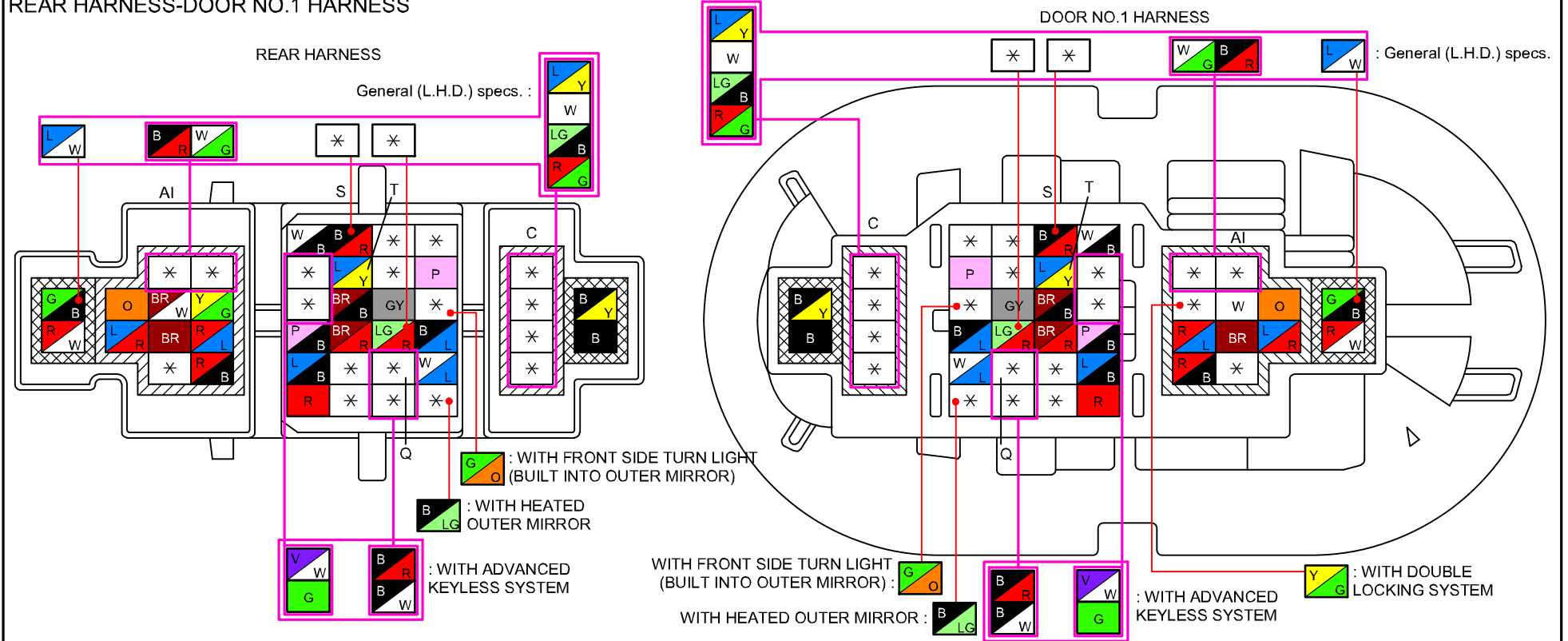

0912-3a

0912-3c

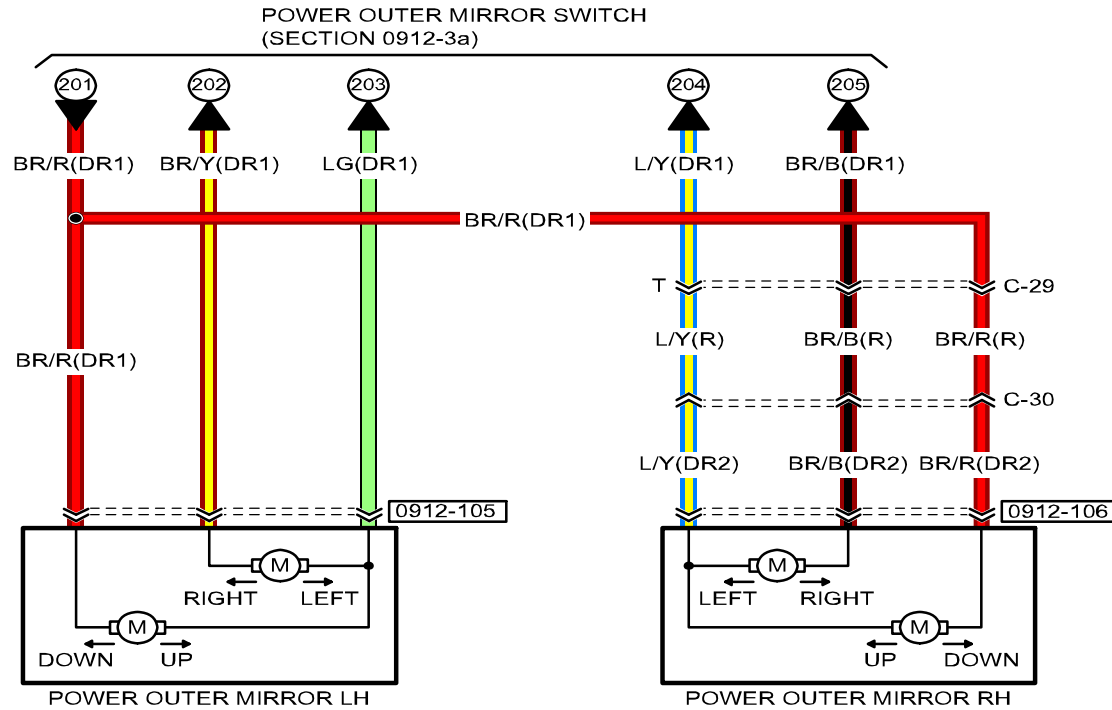

0912-105
HEATED OUTER MIRROR LH /
POWER OUTER MIRROR LH /
RETRACTABLE OUTER MIRROR LH /
FRONT SIDE TURN LIGHT
(BUILT INTO OUTER MIRROR) LH

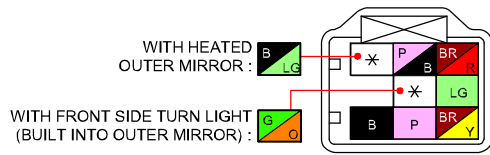

0912-106
HEATED OUTER MIRROR RH /
POWER OUTER MIRROR RH /
RETRACTABLE OUTER MIRROR RH /
FRONT SIDE TURN LIGHT
(BUILT INTO OUTER MIRROR) RH

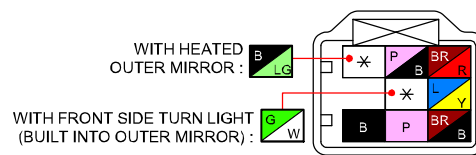

POWER OUTER MIRROR / RETRACTABLE OUTER MIRROR

0912-3b

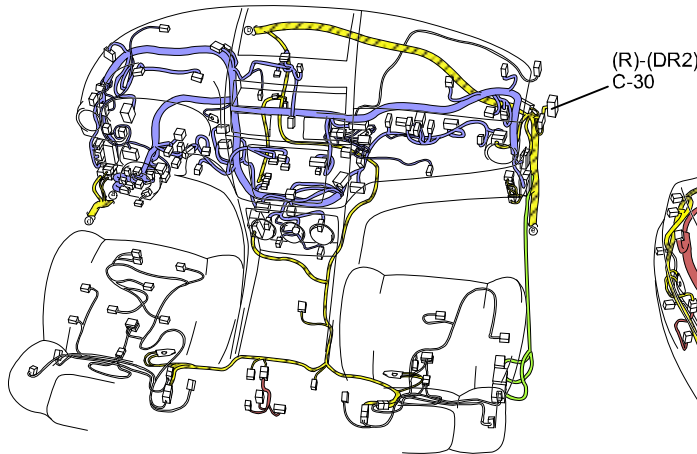

HEATED OUTER MIRROR LH /
POWER OUTER MIRROR LH /
RETRACTABLE OUTER MIRROR LH /
FRONT SIDE TURN LIGHT (BUILT INTO OUTER MIRROR) LH

0912-105

(R)-(DR1)
C-29

HEATED OUTER MIRROR RH /
POWER OUTER MIRROR RH /
RETRACTABLE OUTER MIRROR RH /
FRONT SIDE TURN LIGHT
(BUILT INTO OUTER MIRROR) RH

0912-106

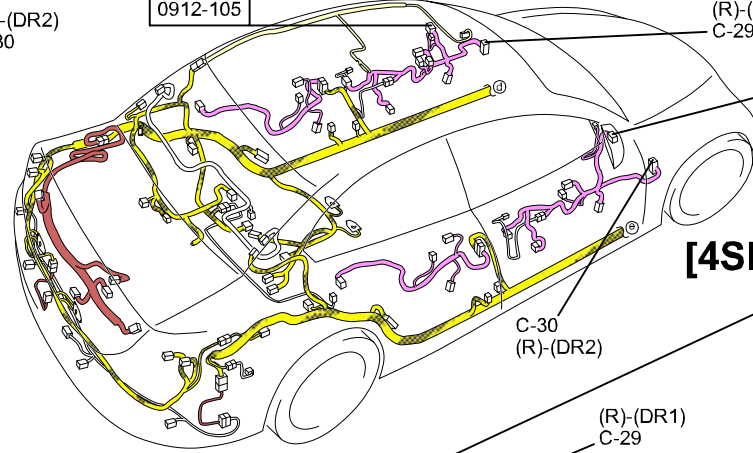

[4SD]

HEATED OUTER MIRROR LH /
POWER OUTER MIRROR LH /
RETRACTABLE OUTER MIRROR LH /
FRONT SIDE TURN LIGHT
(BUILT INTO OUTER MIRROR) LH

0912-105

HEATED OUTER MIRROR RH /
POWER OUTER MIRROR RH /
RETRACTABLE OUTER MIRROR RH /
FRONT SIDE TURN LIGHT
(BUILT INTO OUTER MIRROR) RH

0912-106

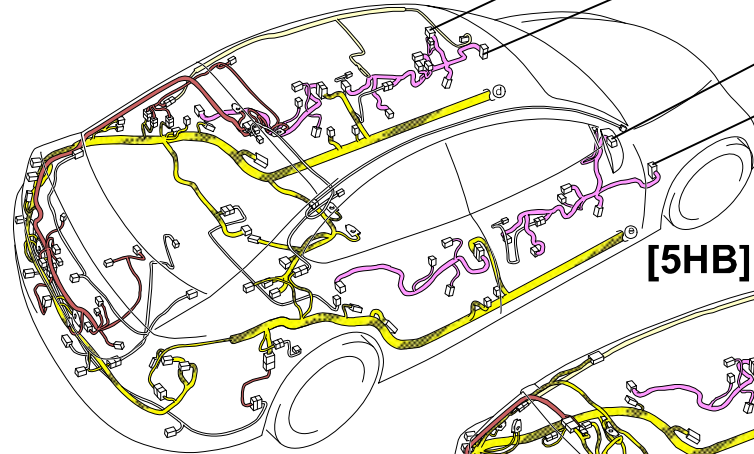
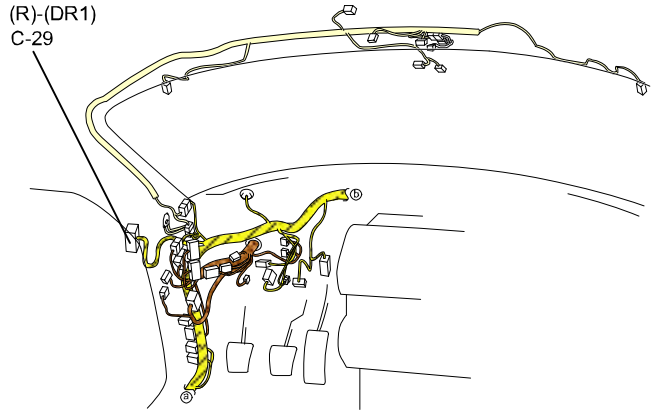

(R)-(DR2)
C-30

HEATED OUTER MIRROR LH /
POWER OUTER MIRROR LH /
RETRACTABLE OUTER MIRROR LH /
FRONT SIDE TURN LIGHT
(BUILT INTO OUTER MIRROR) LH

0912-105

[5HB]

(R)-(DR1)
C-29

- : FRONT HARNESS
- : REAR HARNESS
- : REAR NO.2 HARNESS
- : REAR NO.3 HARNESS
- : REAR NO.4 HARNESS
- : REAR NO.5 HARNESS
- : INSTRUMENT PANEL HARNESS
- : FLOOR HARNESS
- : INTERIOR LIGHT HARNESS
- : INTERIOR LIGHT NO.2 HARNESS
- : DOOR HARNESS

0912-106

HEATED OUTER MIRROR RH /
POWER OUTER MIRROR RH /
RETRACTABLE OUTER MIRROR RH /
FRONT SIDE TURN LIGHT
(BUILT INTO OUTER MIRROR) RH

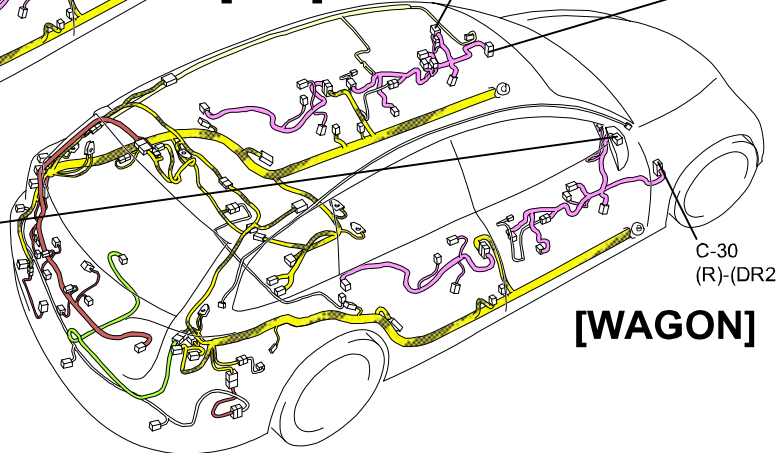

[WAGON]

POWER OUTER MIRROR / RETRACTABLE OUTER MIRROR

0912-3b

C-29

REAR HARNESS-DOOR NO.1 HARNESS

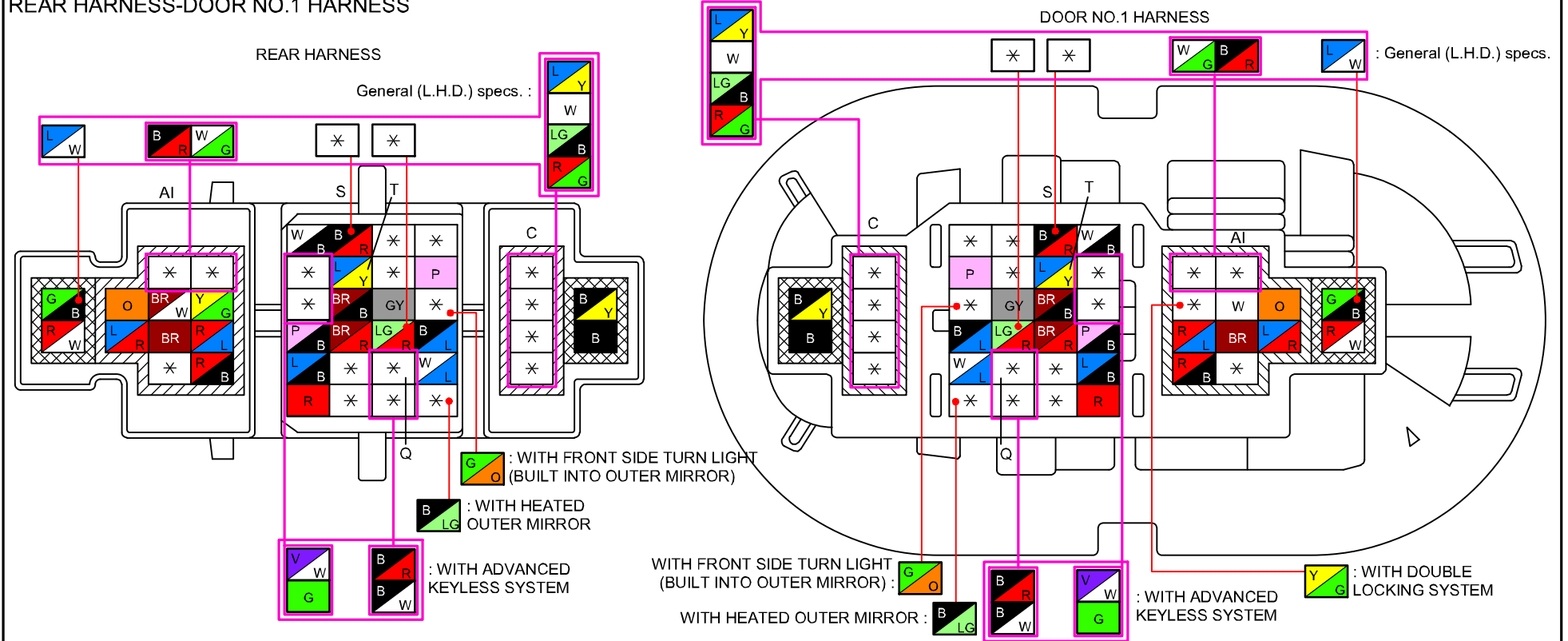

POWER OUTER MIRROR / RETRACTABLE OUTER MIRROR

0912-3b

C-30

REAR HARNESS-DOOR NO.2 HARNESS

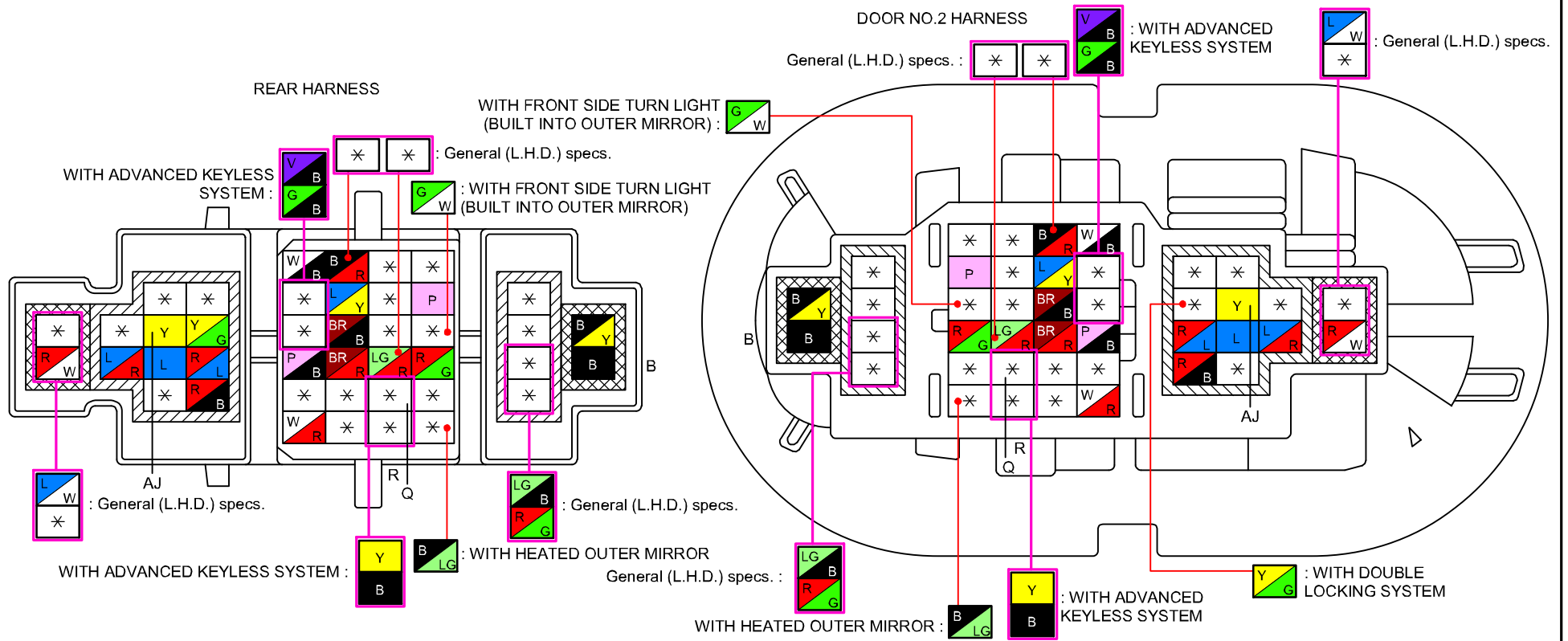

#4 : European (L.H.D.) specs.
&4 : General (L.H.D.) specs.

0912-3b

POWER OUTER MIRROR SWITCH / RETRACTABLE OUTER MIRROR SWITCH

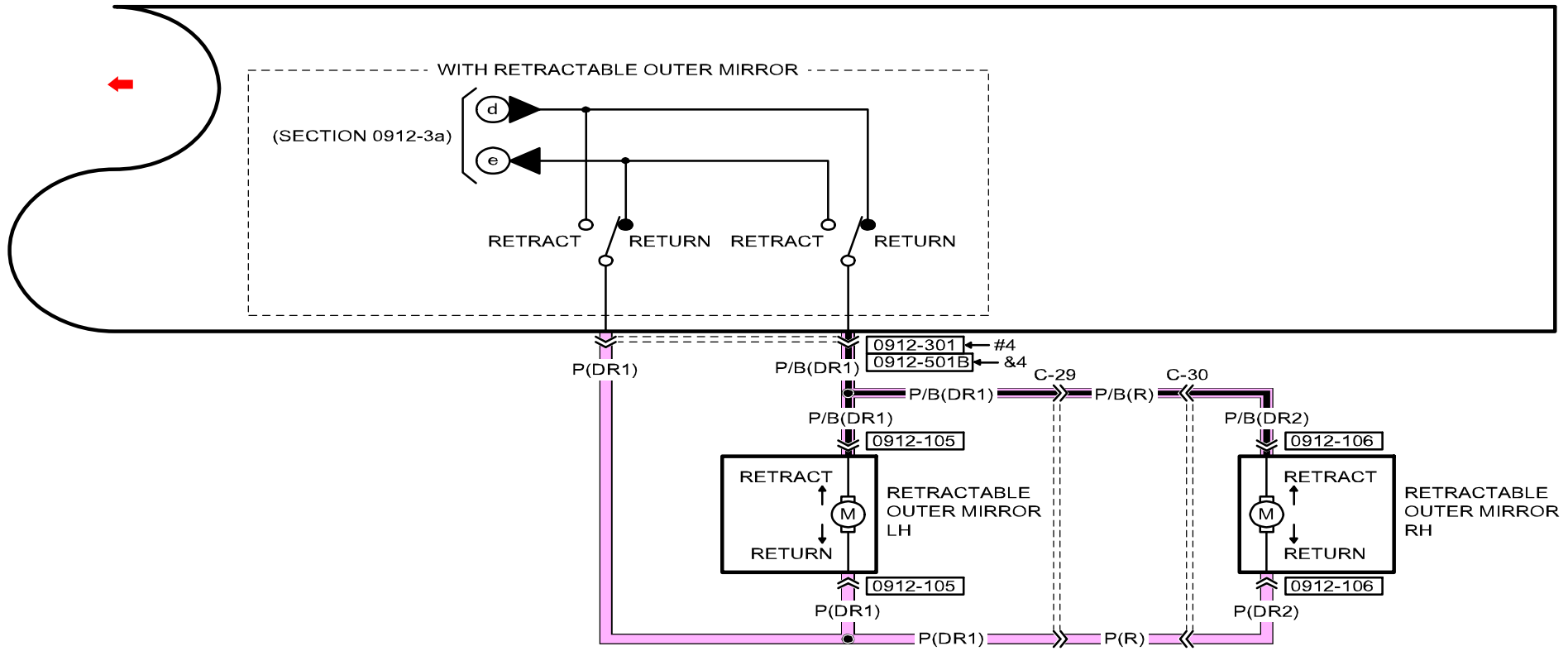

0912-105
HEATED OUTER MIRROR LH /
POWER OUTER MIRROR LH /
RETRACTABLE OUTER MIRROR LH /
FRONT SIDE TURN LIGHT
(BUILT INTO OUTER MIRROR) LH

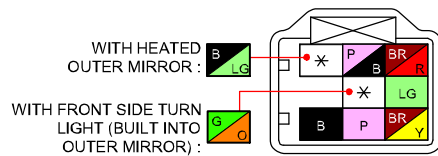

0912-106
HEATED OUTER MIRROR RH /
POWER OUTER MIRROR RH /
RETRACTABLE OUTER MIRROR RH /
FRONT SIDE TURN LIGHT
(BUILT INTO OUTER MIRROR) RH

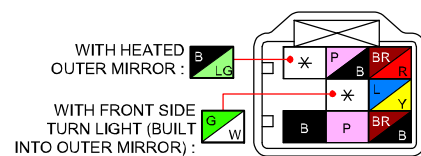

0912-301
POWER OUTER MIRROR SWITCH /
RETRACTABLE OUTER MIRROR SWITCH

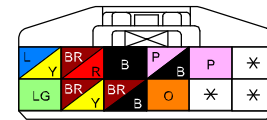

0912-501B
POWER OUTER MIRROR SWITCH /
RETRACTABLE OUTER MIRROR SWITCH /
POWER WINDOW MAIN SWITCH

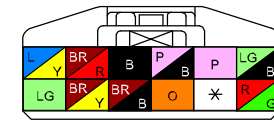

POWER OUTER MIRROR / RETRACTABLE OUTER MIRROR

0912-3c

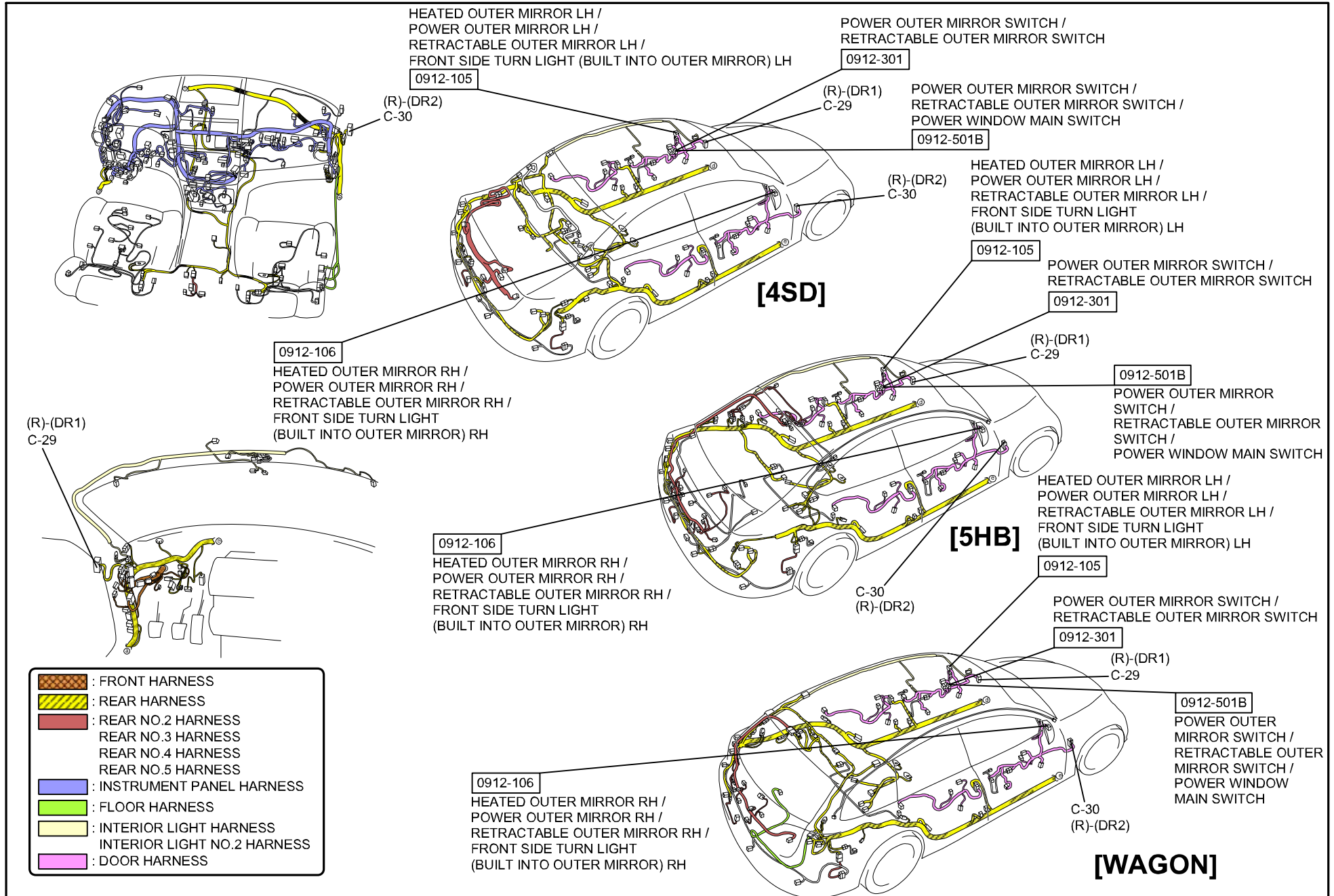

HEATED OUTER MIRROR LH /
POWER OUTER MIRROR LH /
RETRACTABLE OUTER MIRROR LH /
FRONT SIDE TURN LIGHT (BUILT INTO OUTER MIRROR) LH
0912-105

POWER OUTER MIRROR SWITCH /
RETRACTABLE OUTER MIRROR SWITCH
0912-301

(R)-(DR2)
C-30

(R)-(DR1)
C-29

POWER OUTER MIRROR SWITCH /
RETRACTABLE OUTER MIRROR SWITCH /
POWER WINDOW MAIN SWITCH
0912-501B

[4SD]

HEATED OUTER MIRROR LH /
POWER OUTER MIRROR LH /
RETRACTABLE OUTER MIRROR LH /
FRONT SIDE TURN LIGHT
(BUILT INTO OUTER MIRROR) LH
0912-105

POWER OUTER MIRROR SWITCH /
RETRACTABLE OUTER MIRROR SWITCH
0912-301

(R)-(DR2)
C-30

(R)-(DR1)
C-29

0912-501B

POWER OUTER MIRROR
SWITCH /
RETRACTABLE OUTER MIRROR
SWITCH /
POWER WINDOW MAIN SWITCH

0912-106

HEATED OUTER MIRROR RH /
POWER OUTER MIRROR RH /
RETRACTABLE OUTER MIRROR RH /
FRONT SIDE TURN LIGHT
(BUILT INTO OUTER MIRROR) RH

(R)-(DR1)
C-29

[5HB]

HEATED OUTER MIRROR LH /
POWER OUTER MIRROR LH /
RETRACTABLE OUTER MIRROR LH /
FRONT SIDE TURN LIGHT
(BUILT INTO OUTER MIRROR) LH
0912-105

0912-105

POWER OUTER MIRROR SWITCH /
RETRACTABLE OUTER MIRROR SWITCH
0912-301

C-30
(R)-(DR2)

(R)-(DR1)
C-29

0912-501B

POWER OUTER
MIRROR SWITCH /
RETRACTABLE OUTER
MIRROR SWITCH /
POWER WINDOW
MAIN SWITCH

0912-106

HEATED OUTER MIRROR RH /
POWER OUTER MIRROR RH /
RETRACTABLE OUTER MIRROR RH /
FRONT SIDE TURN LIGHT
(BUILT INTO OUTER MIRROR) RH

0912-106

HEATED OUTER MIRROR RH /
POWER OUTER MIRROR RH /
RETRACTABLE OUTER MIRROR RH /
FRONT SIDE TURN LIGHT
(BUILT INTO OUTER MIRROR) RH

C-30
(R)-(DR2)

[WAGON]

- : FRONT HARNESS
- : REAR HARNESS
- : REAR NO.2 HARNESS
- : REAR NO.3 HARNESS
- : REAR NO.4 HARNESS
- : REAR NO.5 HARNESS
- : INSTRUMENT PANEL HARNESS
- : FLOOR HARNESS
- : INTERIOR LIGHT HARNESS
- : INTERIOR LIGHT NO.2 HARNESS
- : DOOR HARNESS

POWER OUTER MIRROR / RETRACTABLE OUTER MIRROR

0912-3c

C-29

REAR HARNESS-DOOR NO.1 HARNESS

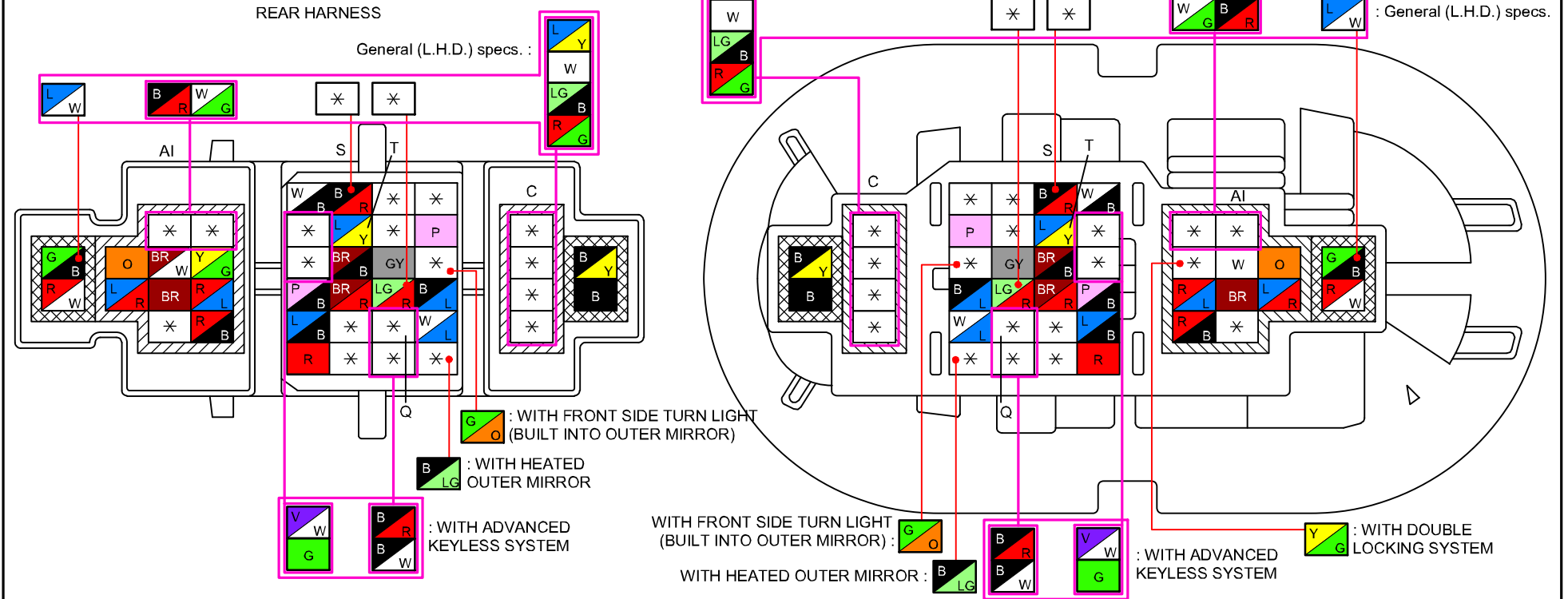

POWER OUTER MIRROR / RETRACTABLE OUTER MIRROR

0912-3c

C-30

REAR HARNESS-DOOR NO.2 HARNESS

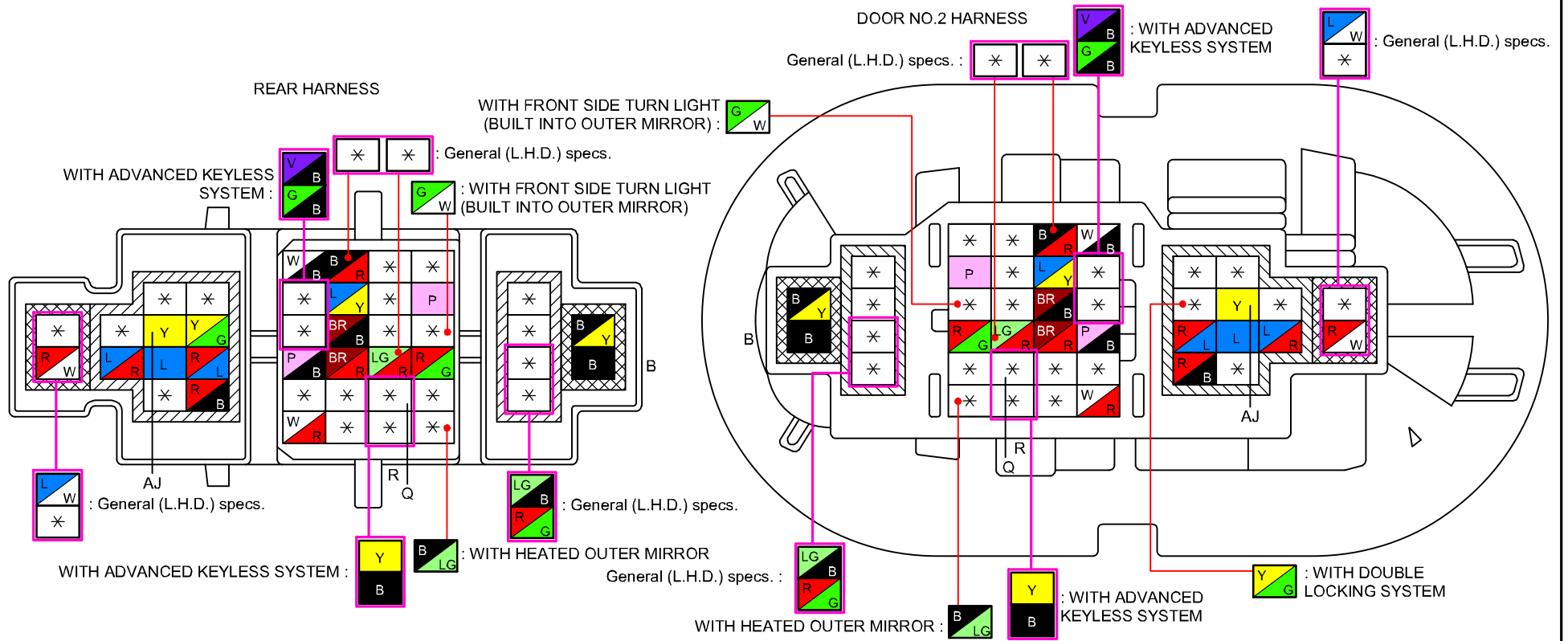

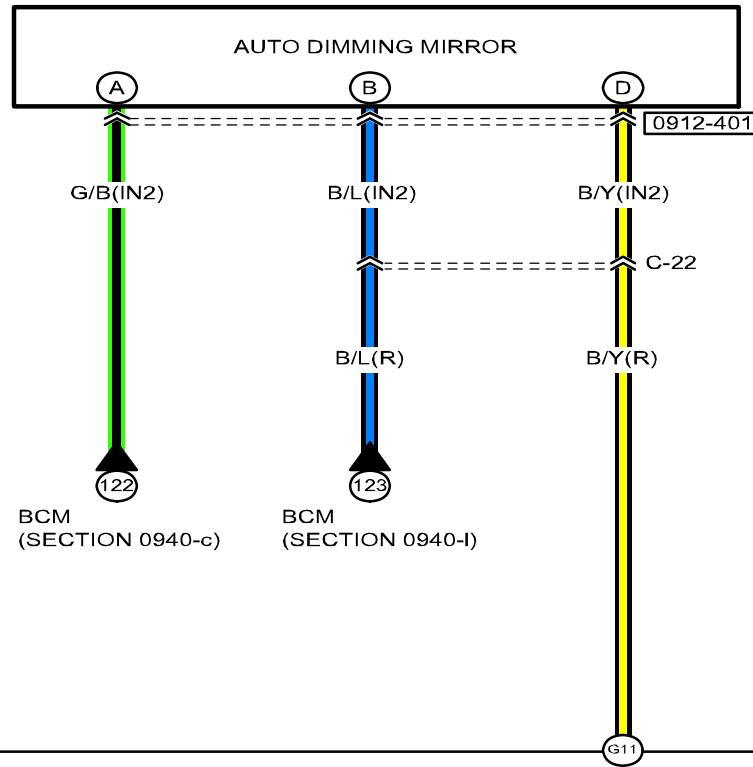



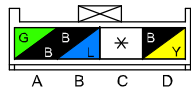

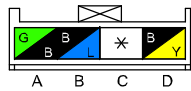

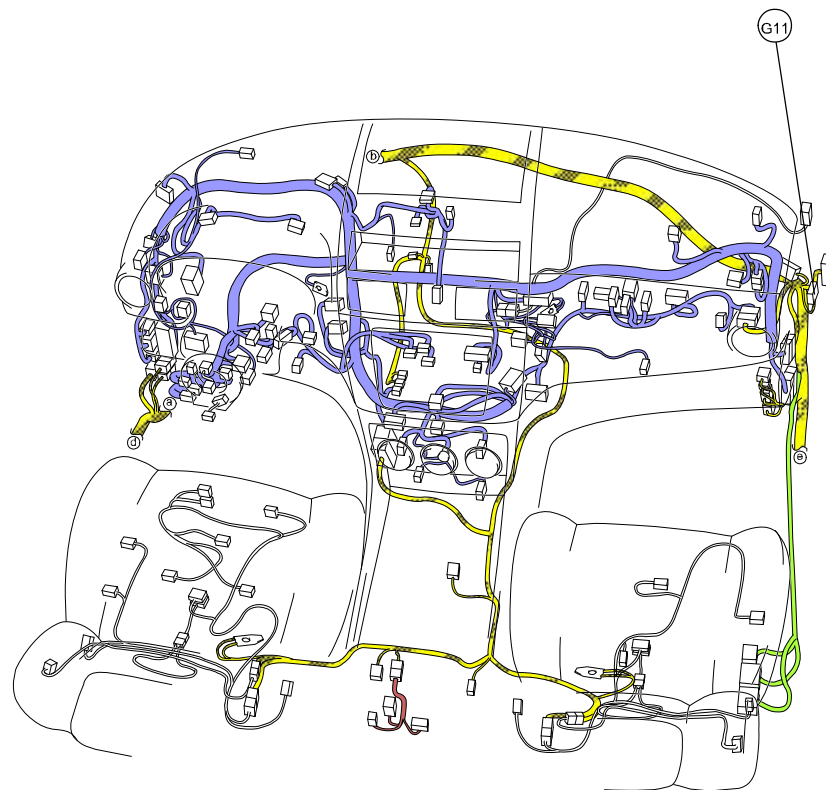
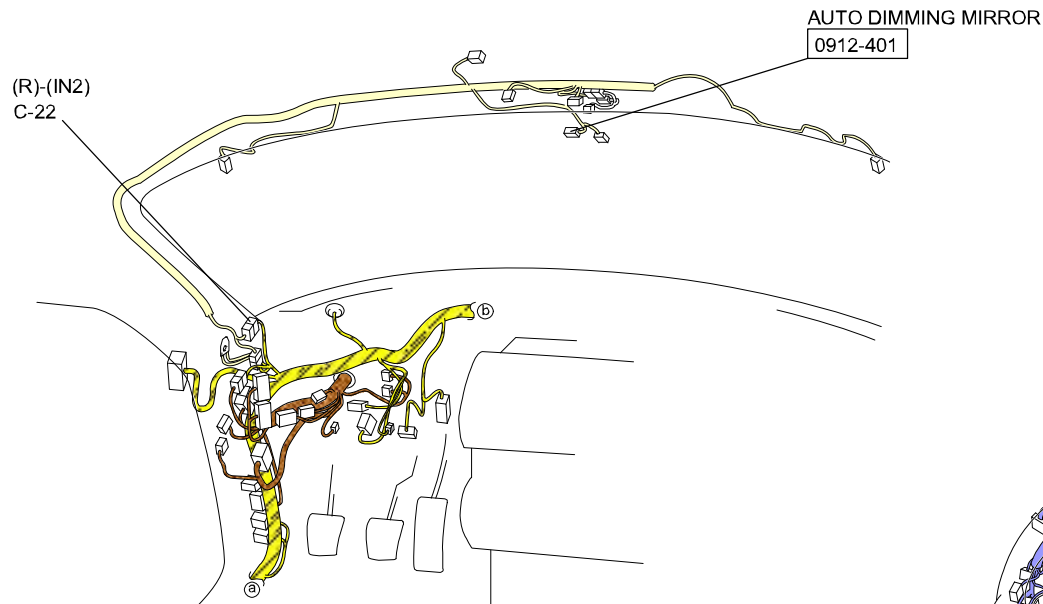
0912-401
AUTO DIMMING MIRROR



0912-401 AUTO DIMMING MIRROR						
						



-  : FRONT HARNESS
-  : REAR HARNESS
-  : REAR NO.5 HARNESS
-  : INSTRUMENT PANEL HARNESS
-  : FLOOR HARNESS
-  : INTERIOR LIGHT NO.2 HARNESS

C-22

REAR HARNESS-INTERIOR LIGHT NO.2 HARNESS

REAR HARNESS

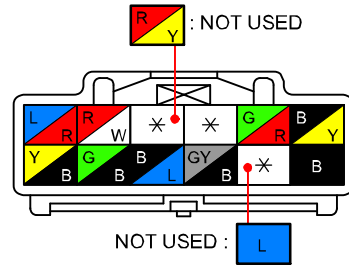

INTERIOR LIGHT NO.2 HARNESS

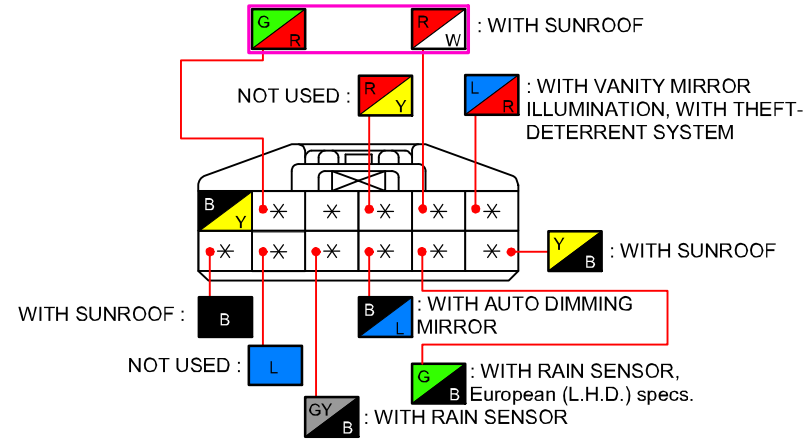

POWER WINDOW SYSTEM (General (L.H.D.) specs.)

0912-5a

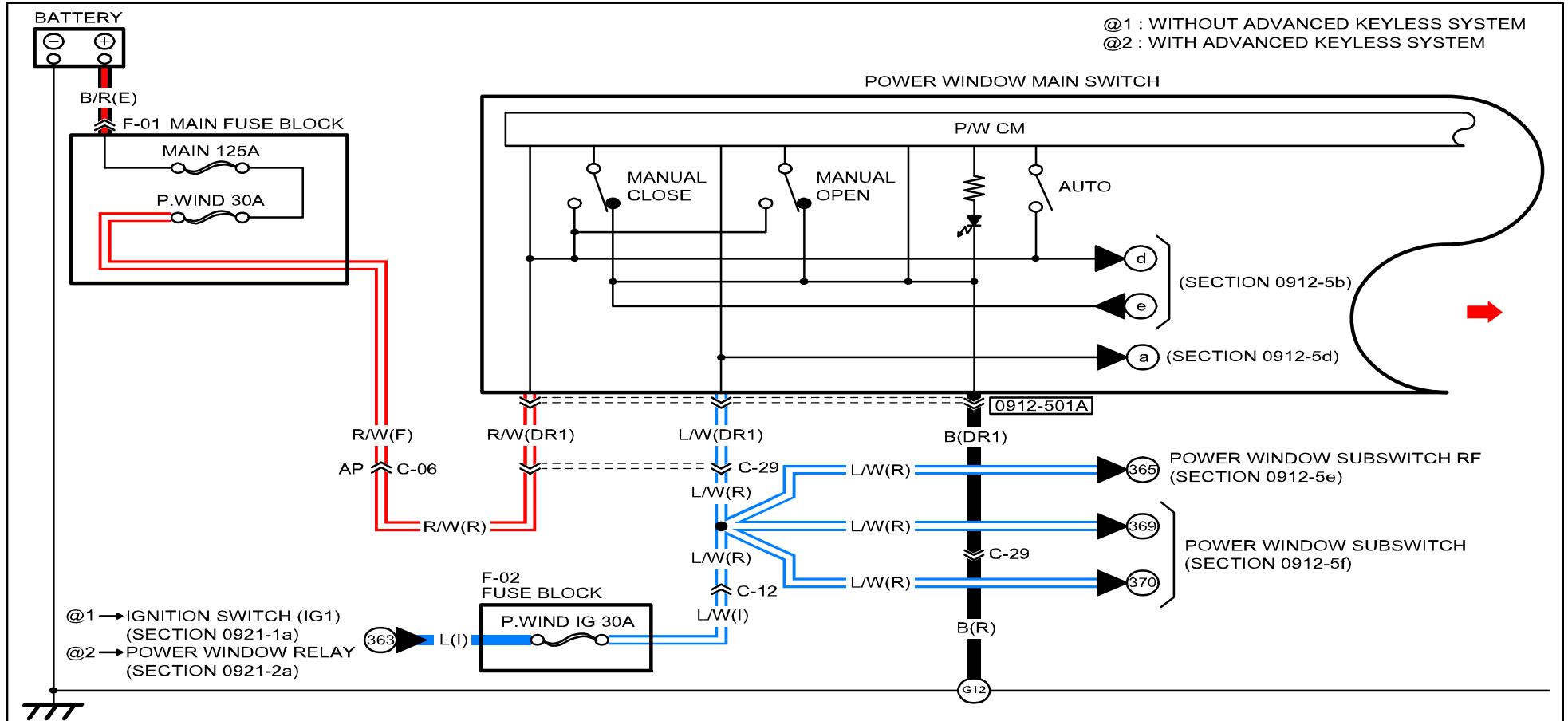

<p>0912-501A POWER WINDOW MAIN SWITCH</p>					

POWER WINDOW SYSTEM (General (L.H.D.) specs.)

0912-5a

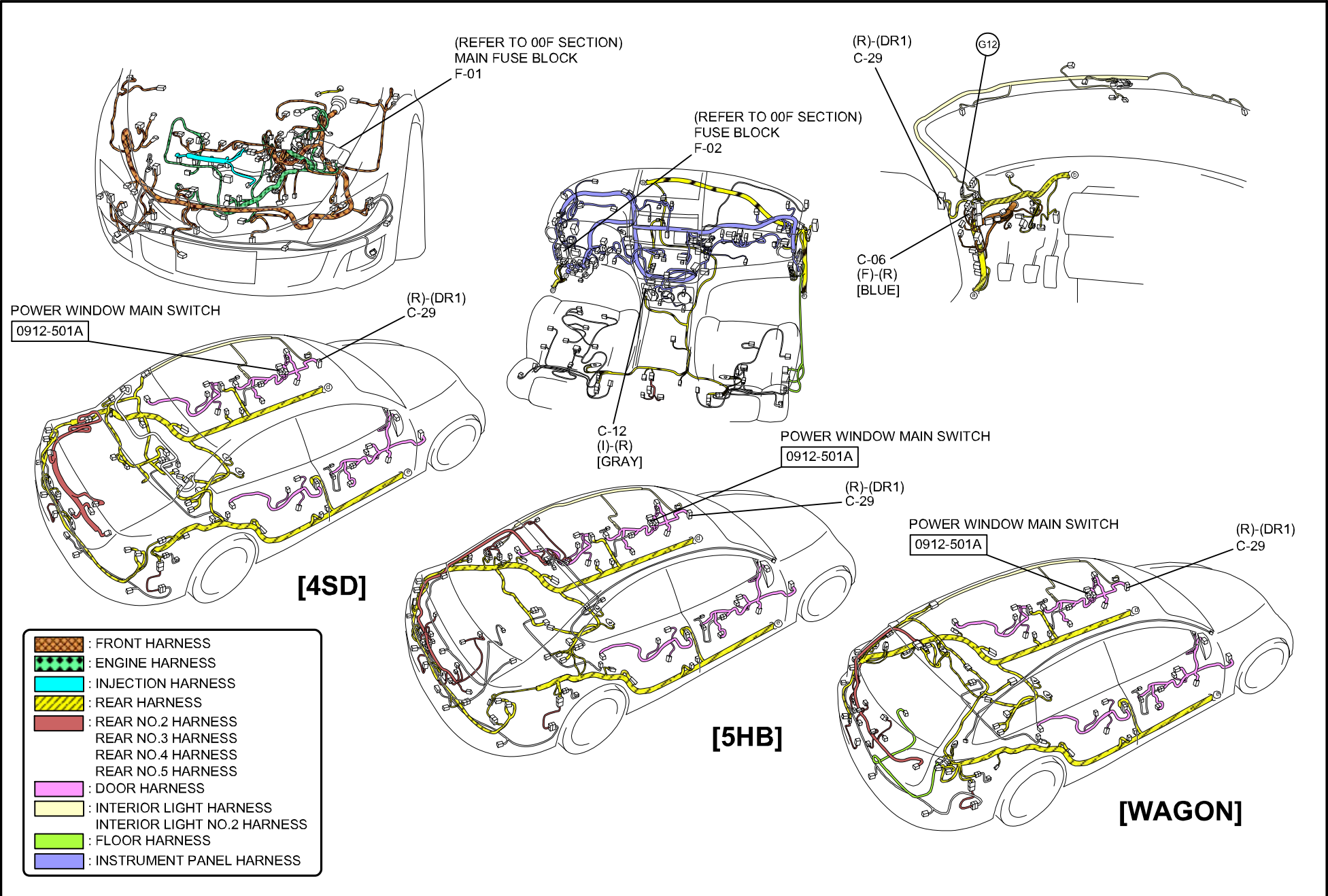

C-06

FRONT HARNESS-REAR HARNESS

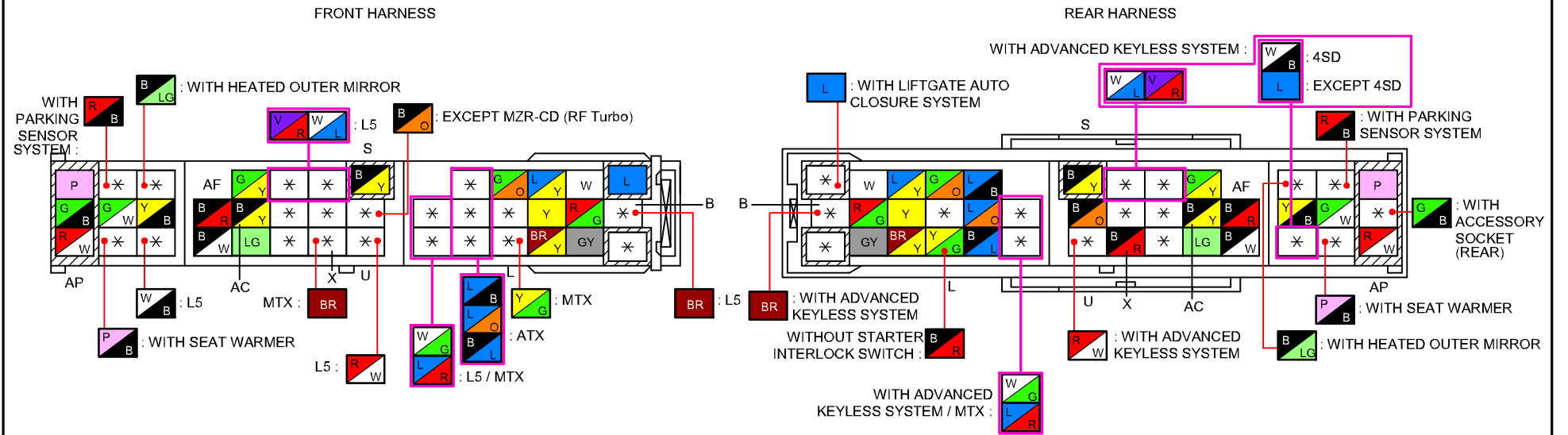

C-12

INSTRUMENT PANEL HARNESS-REAR HARNESS

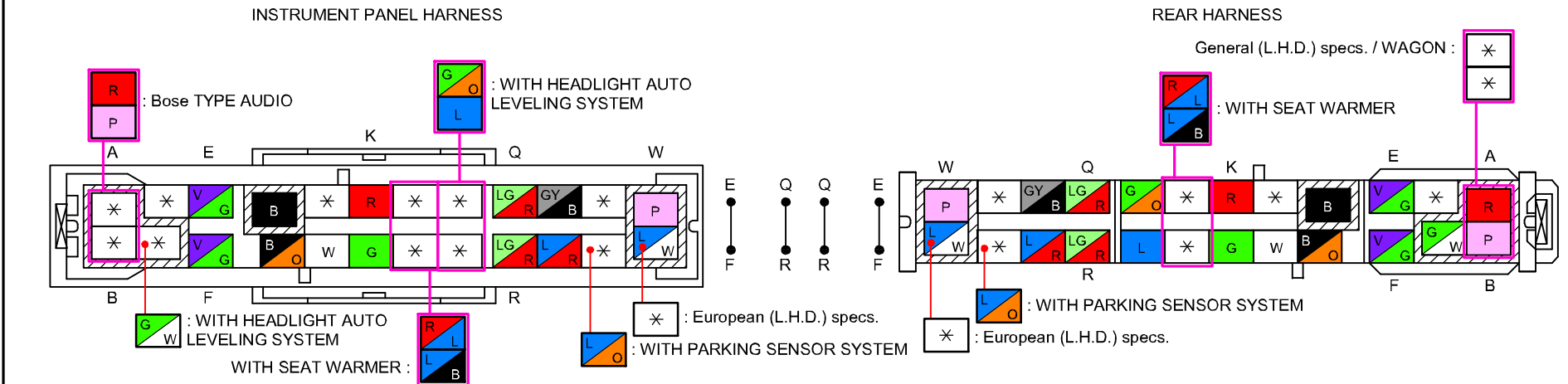

C-29



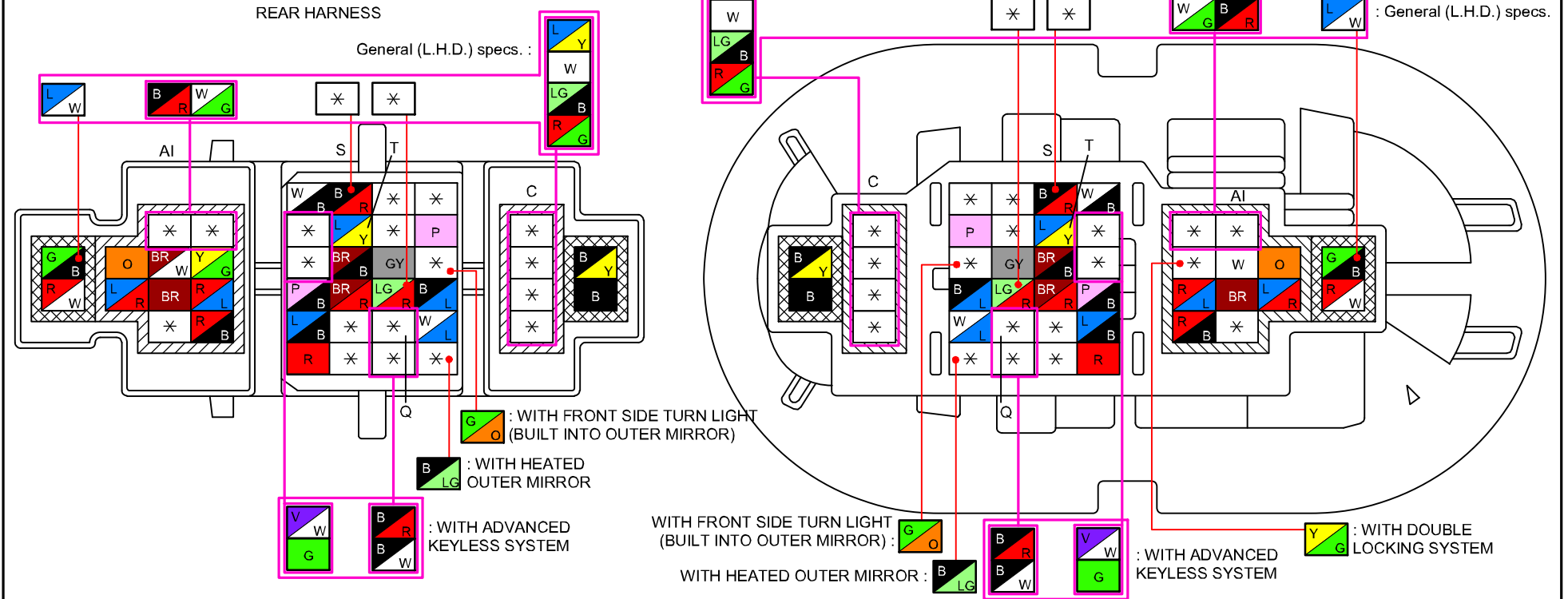

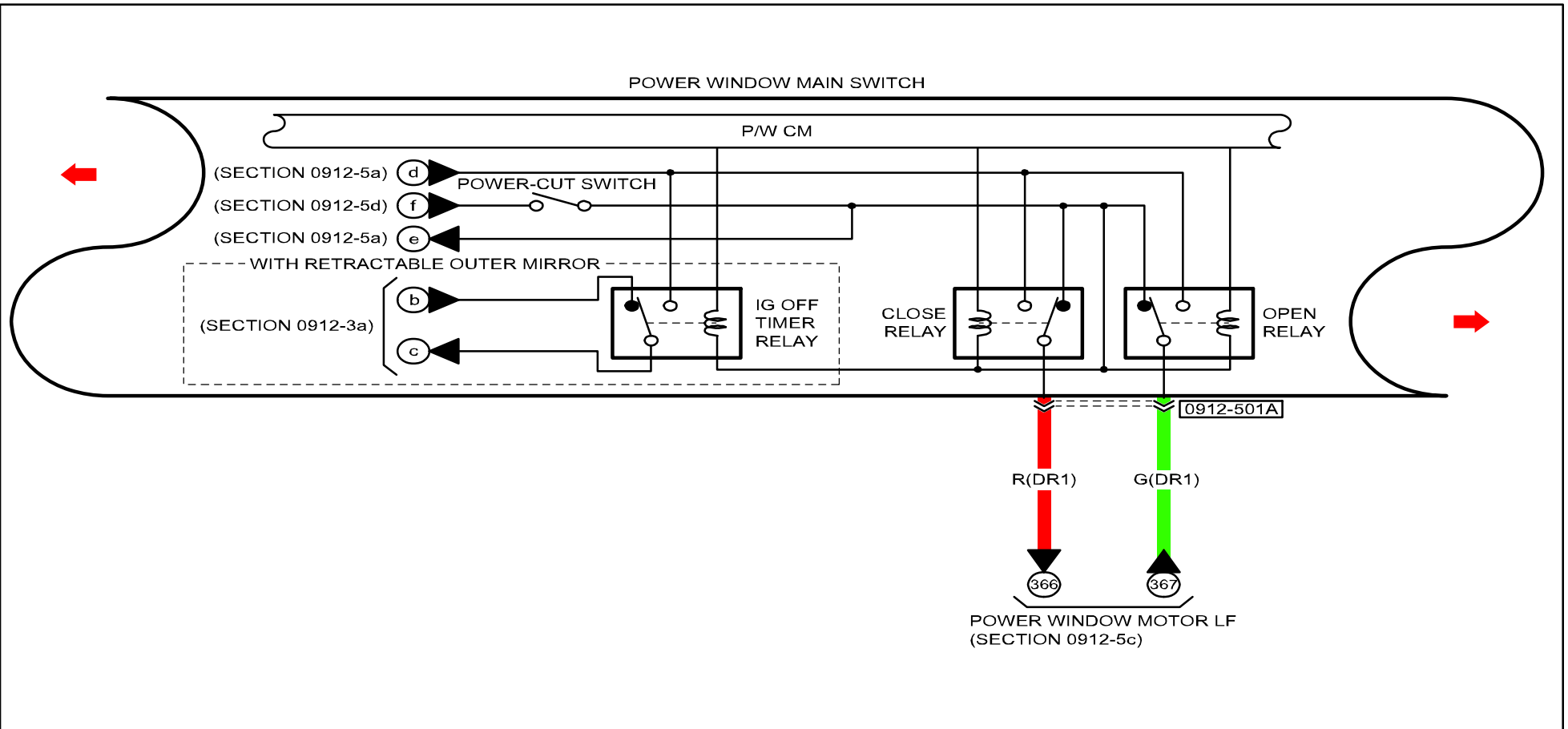
REAR HARNESS-DOOR NO.1 HARNESS



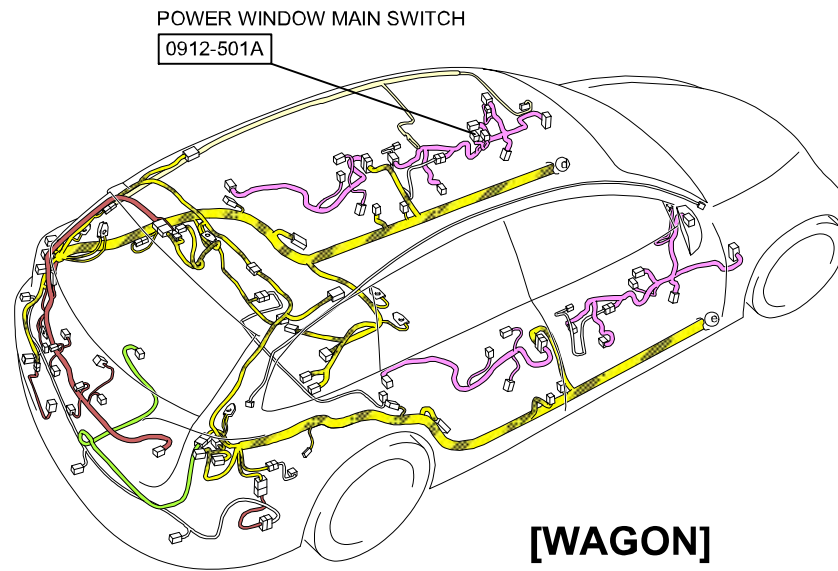
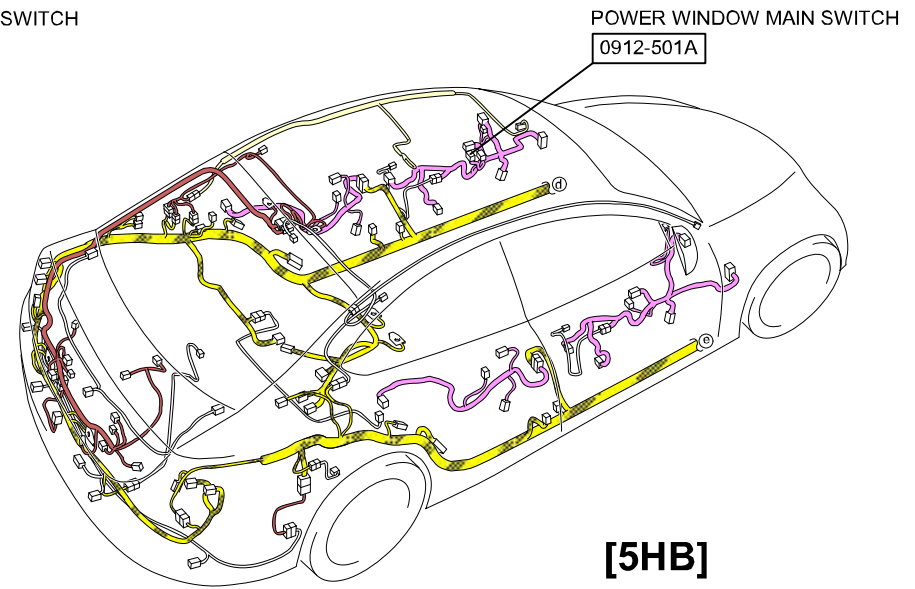
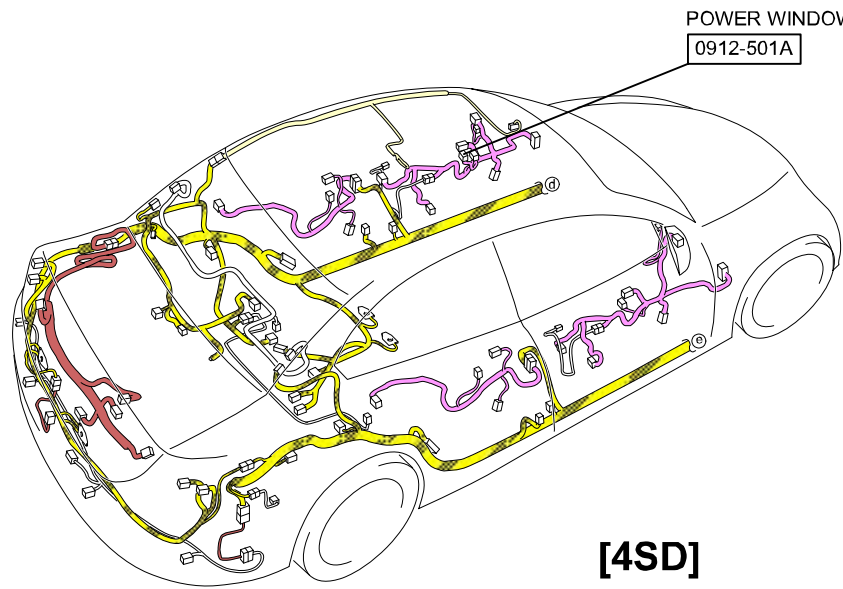

<p>0912-501A POWER WINDOW MAIN SWITCH</p>						





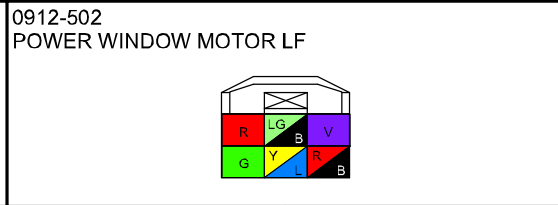
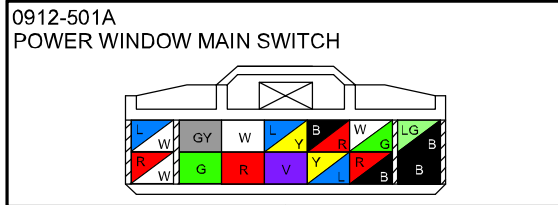
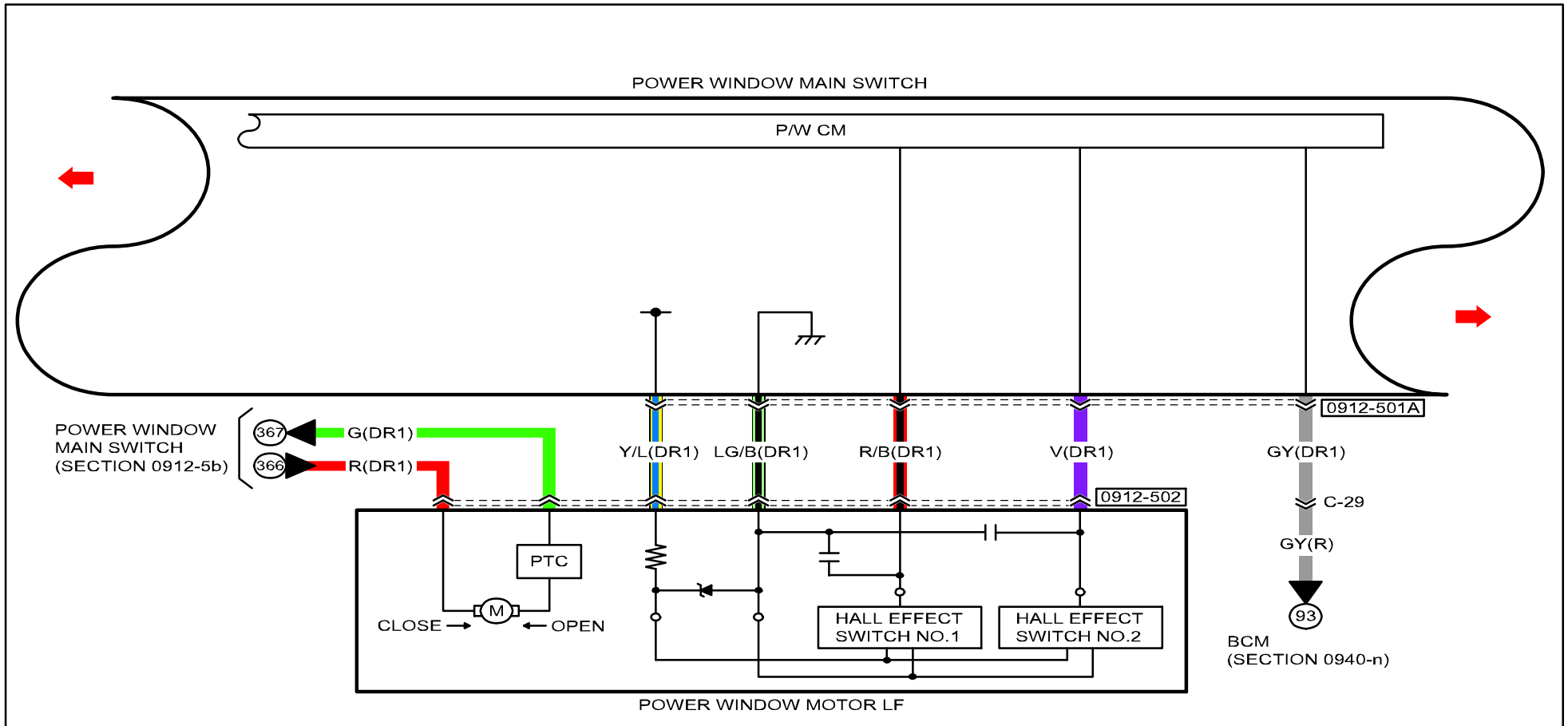





-  : REAR HARNESS
-  : REAR NO.2 HARNESS
REAR NO.3 HARNESS
REAR NO.4 HARNESS
-  : DOOR HARNESS
-  : INTERIOR LIGHT HARNESS
-  : FLOOR HARNESS



--	--	--	--	--	--

POWER WINDOW SYSTEM (General (L.H.D.) specs.)

0912-5c

-  : FRONT HARNESS
-  : REAR HARNESS
-  : REAR NO.2 HARNESS
-  : REAR NO.3 HARNESS
-  : REAR NO.4 HARNESS
-  : DOOR HARNESS
-  : INTERIOR LIGHT HARNESS
-  : INTERIOR LIGHT NO.2 HARNESS
-  : FLOOR HARNESS

(R)-(DR1)
C-29

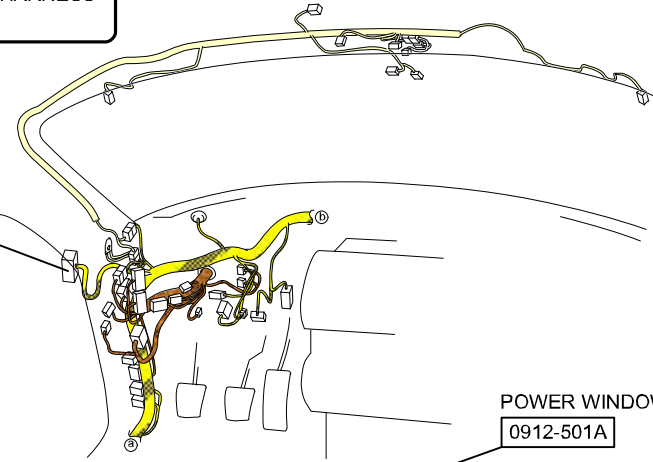

POWER WINDOW MAIN SWITCH
0912-501A

POWER WINDOW MOTOR LF
0912-502

(R)-(DR1)
C-29

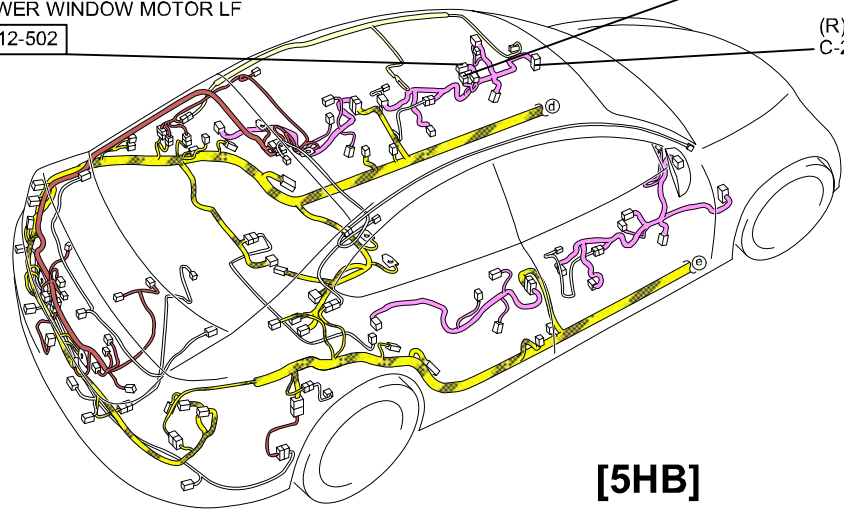

[5HB]

POWER WINDOW MOTOR LF
0912-502

POWER WINDOW MAIN SWITCH
0912-501A

(R)-(DR1)
C-29

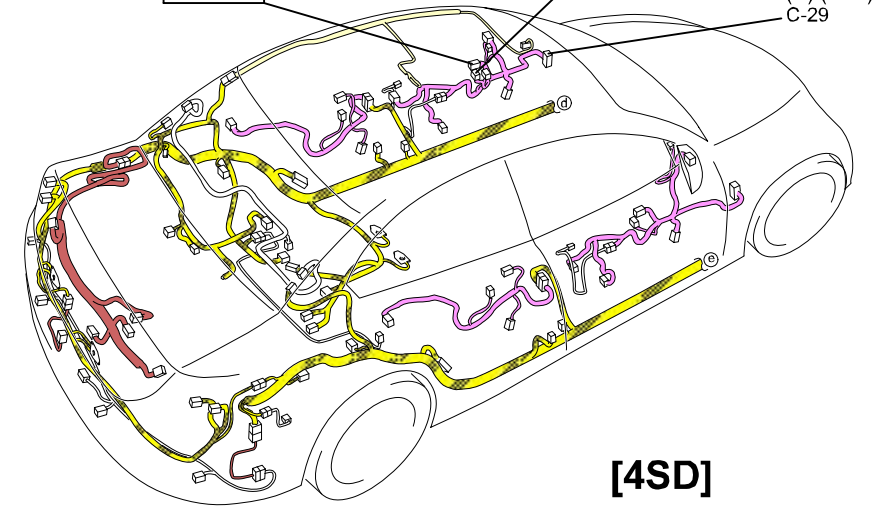

[4SD]

POWER WINDOW MOTOR LF
0912-502

POWER WINDOW MAIN SWITCH
0912-501A

(R)-(DR1)
C-29

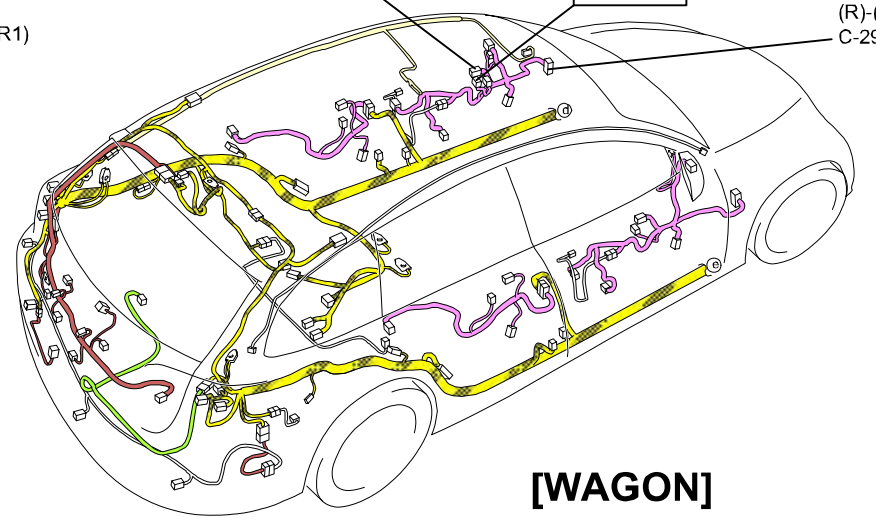

[WAGON]

C-29

REAR HARNESS-DOOR NO.1 HARNESS

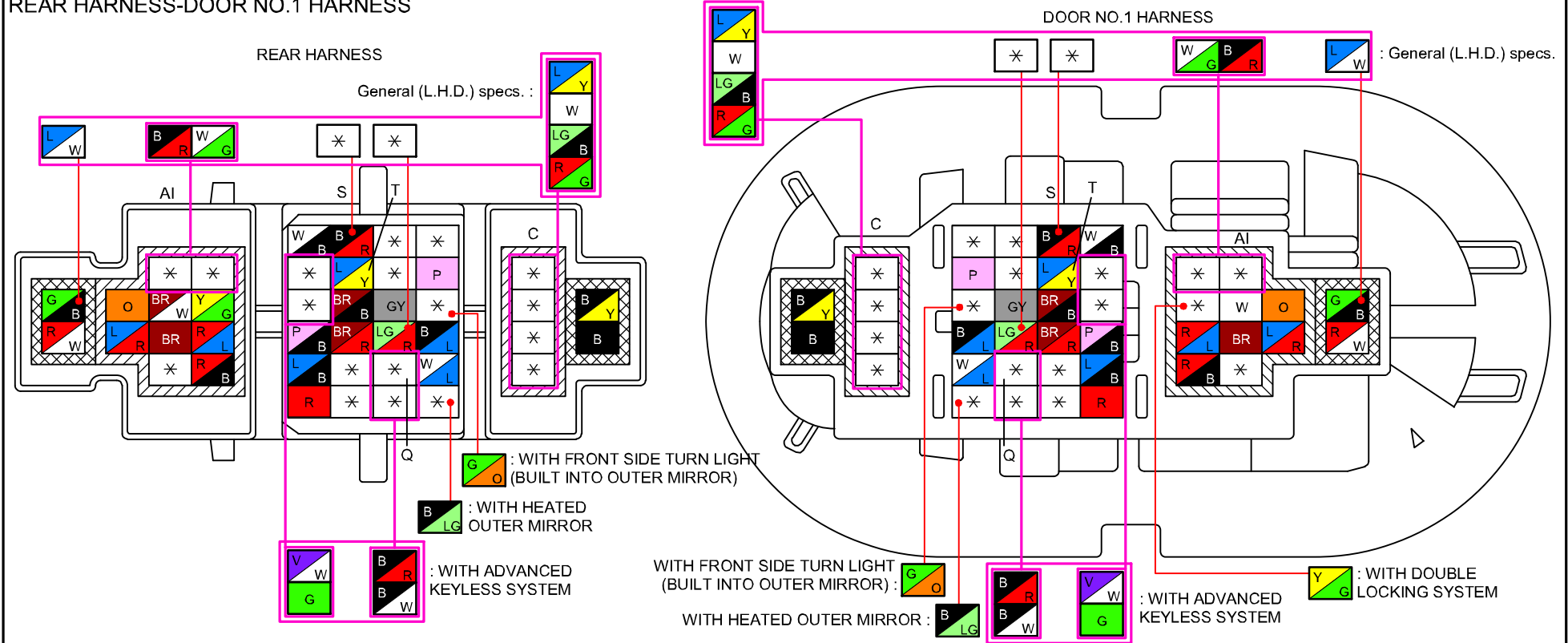

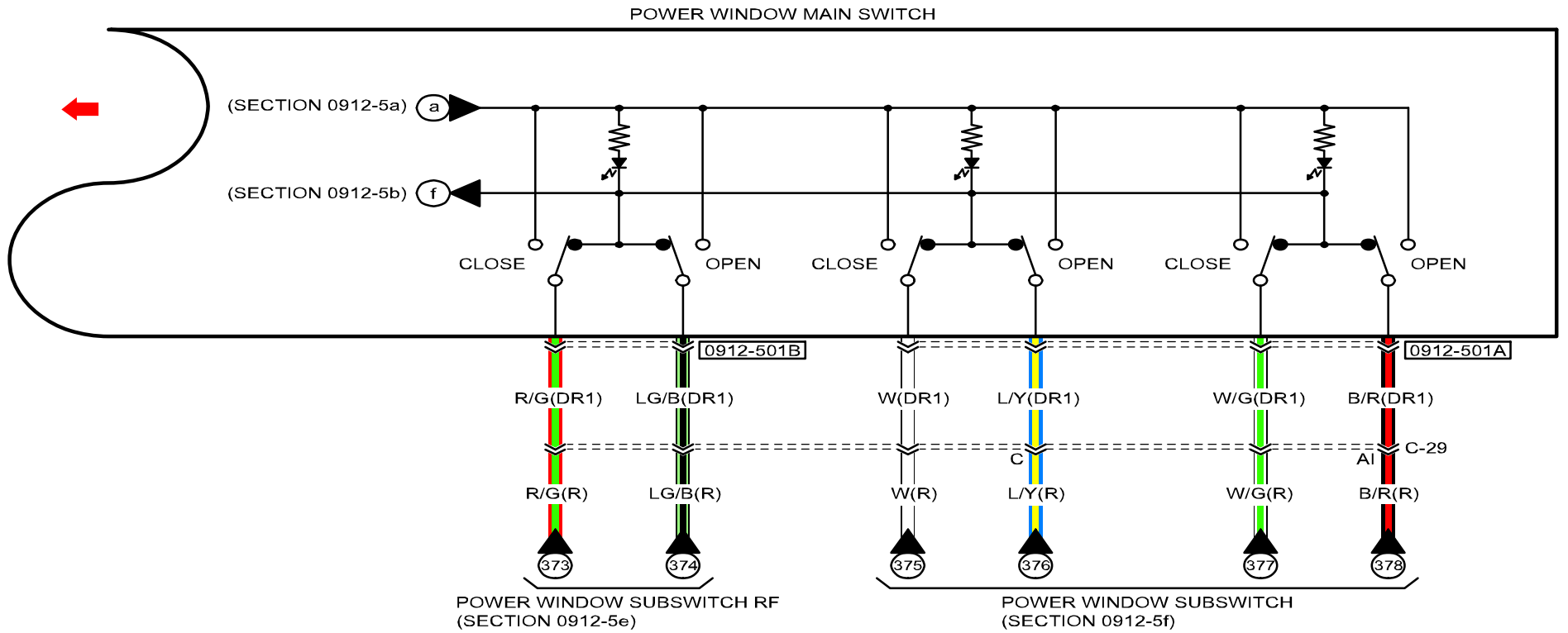

0912-501A
POWER WINDOW MAIN SWITCH

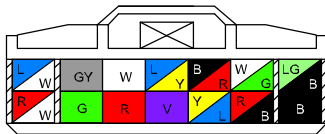



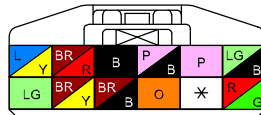



0912-501B
POWER OUTER MIRROR SWITCH /
RETRACTABLE OUTER MIRROR SWITCH /
POWER WINDOW MAIN SWITCH



POWER WINDOW SYSTEM (General (L.H.D.) specs.)

0912-5d

-  : FRONT HARNESS
-  : REAR HARNESS
-  : REAR NO.2 HARNESS
REAR NO.3 HARNESS
REAR NO.4 HARNESS
-  : DOOR HARNESS
-  : INTERIOR LIGHT HARNESS
INTERIOR LIGHT NO.2 HARNESS
-  : FLOOR HARNESS

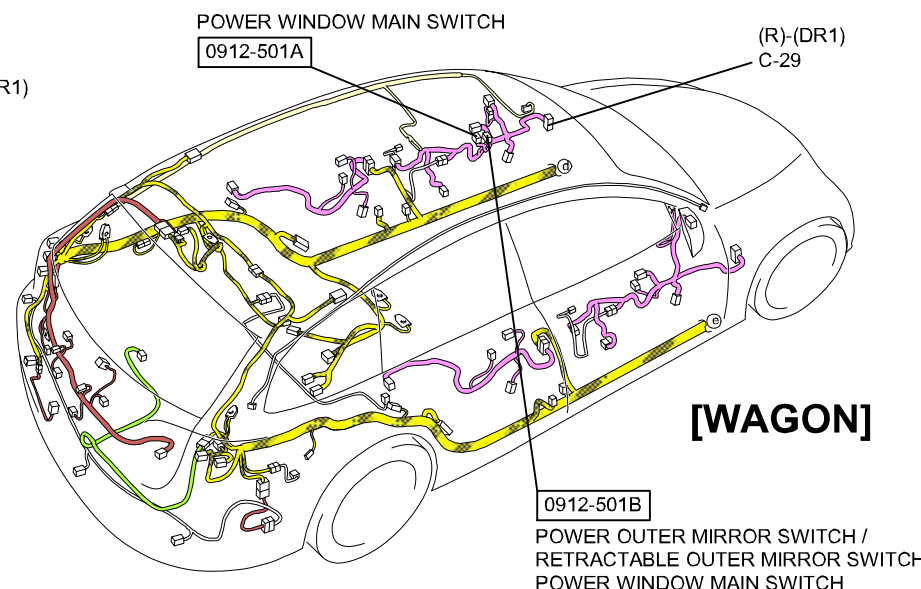
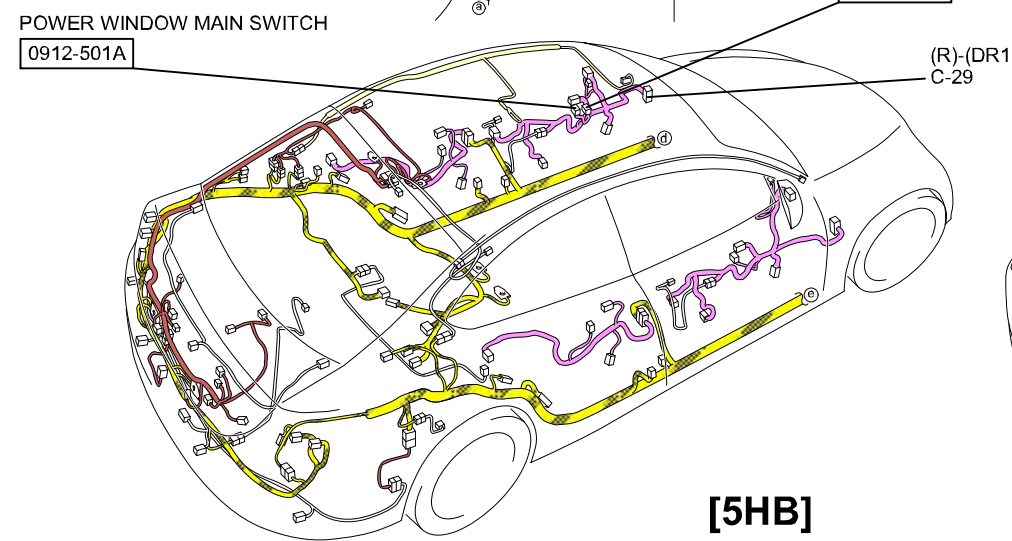
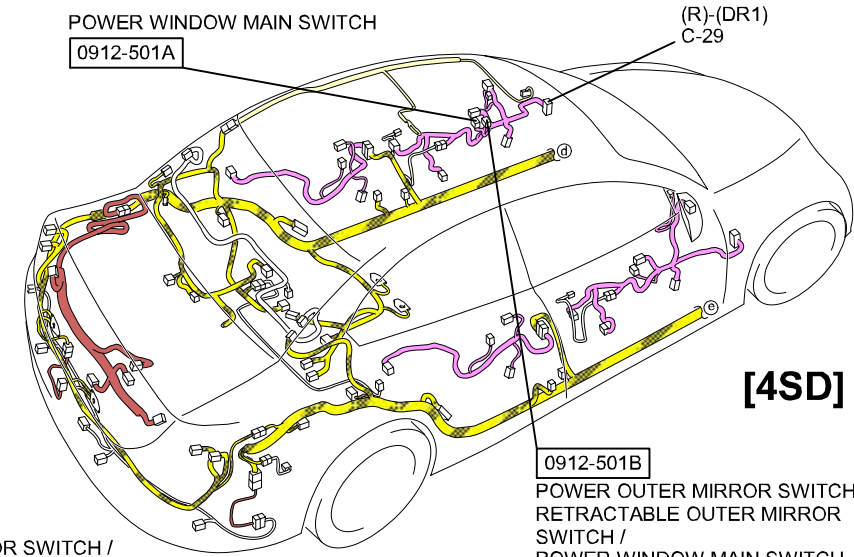
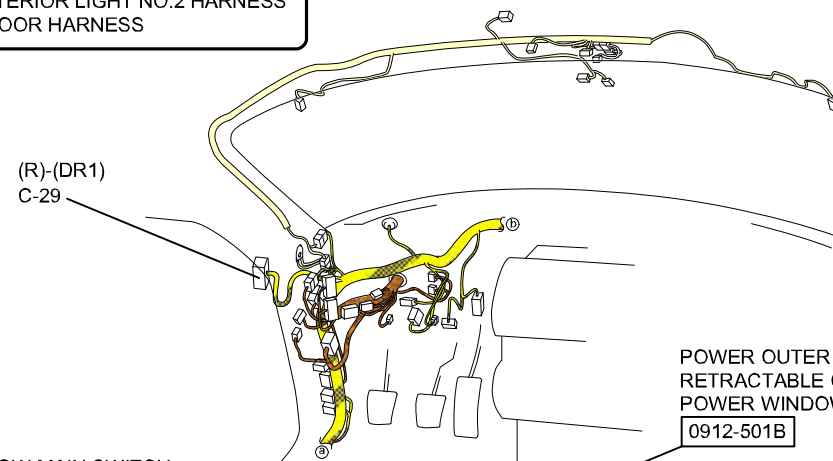

C-29

REAR HARNESS-DOOR NO.1 HARNESS

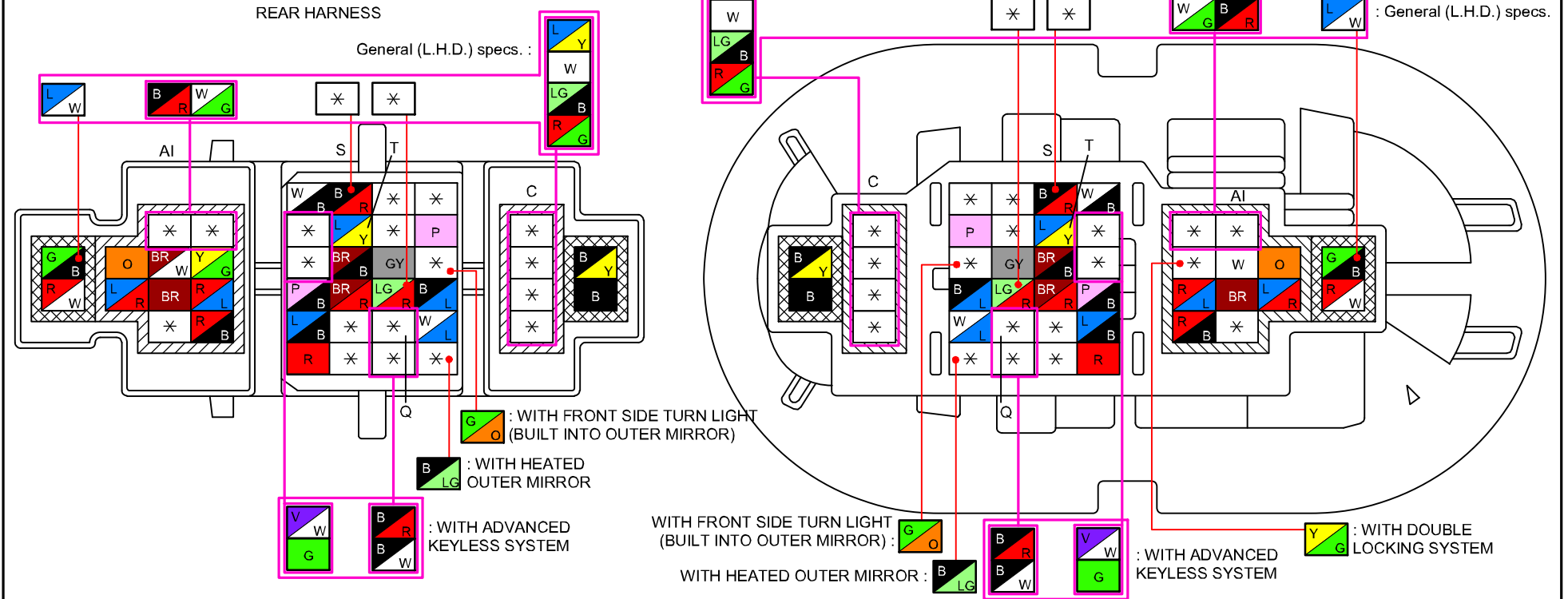

@1 : WITHOUT ADVANCED KEYLESS SYSTEM
 @2 : WITH ADVANCED KEYLESS SYSTEM

← 0912-5d

0912-5f →

@1 → IGNITION SWITCH (IG1)
 @2 → POWER WINDOW RELAY (SECTION 0912-5a)

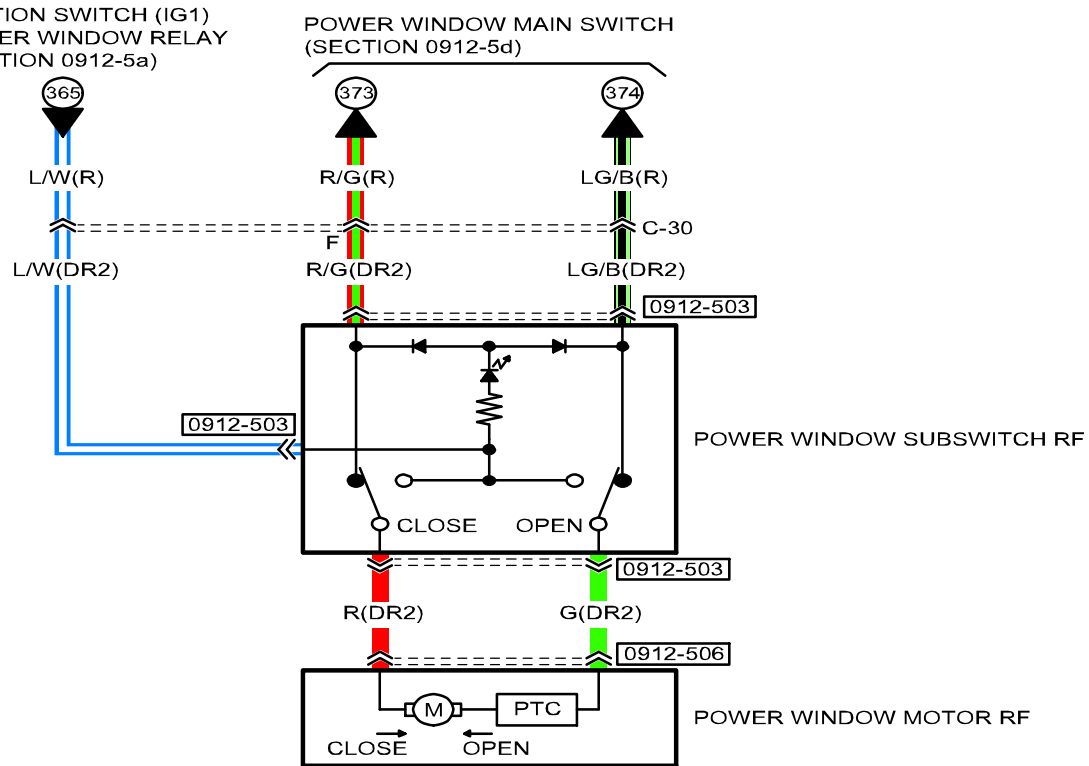

0912-503
POWER WINDOW SUBSWITCH RF

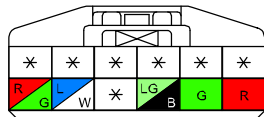

0912-506
POWER WINDOW MOTOR RF

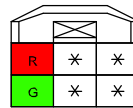

POWER WINDOW SYSTEM (General (L.H.D.) specs.)

0912-5e

- : INSTRUMENT PANEL HARNESS
- : REAR HARNESS
- : REAR NO.2 HARNESS
- : REAR NO.3 HARNESS
- : REAR NO.4 HARNESS
- : REAR NO.5 HARNESS
- : DOOR HARNESS
- : INTERIOR LIGHT HARNESS
- : FLOOR HARNESS

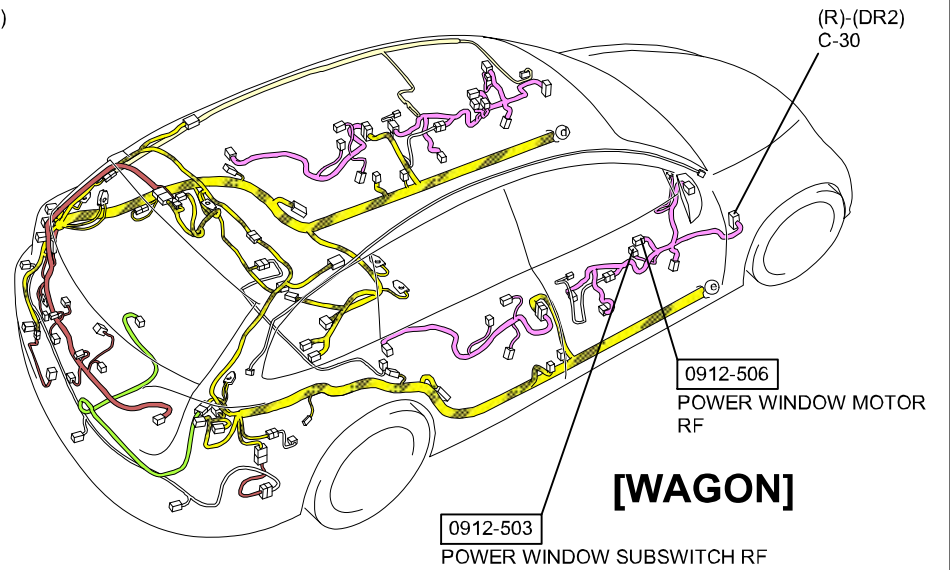
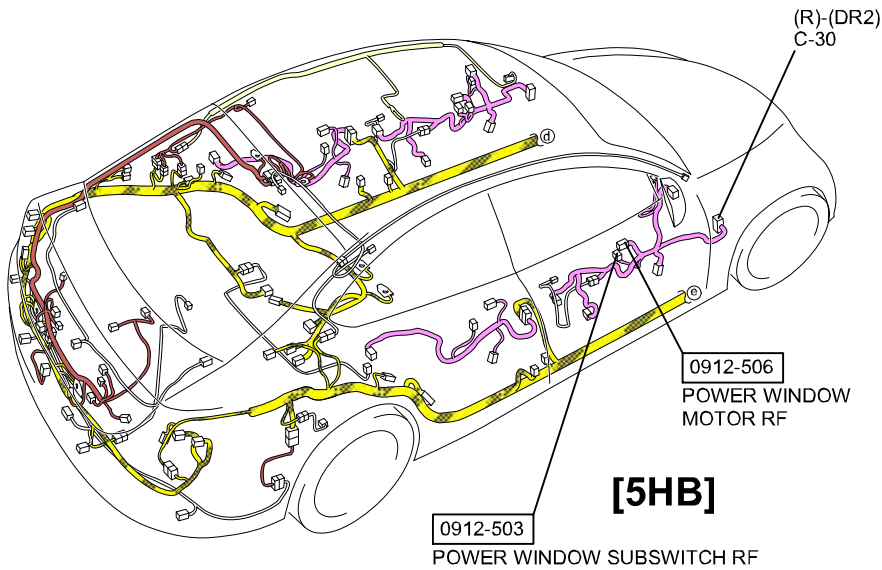
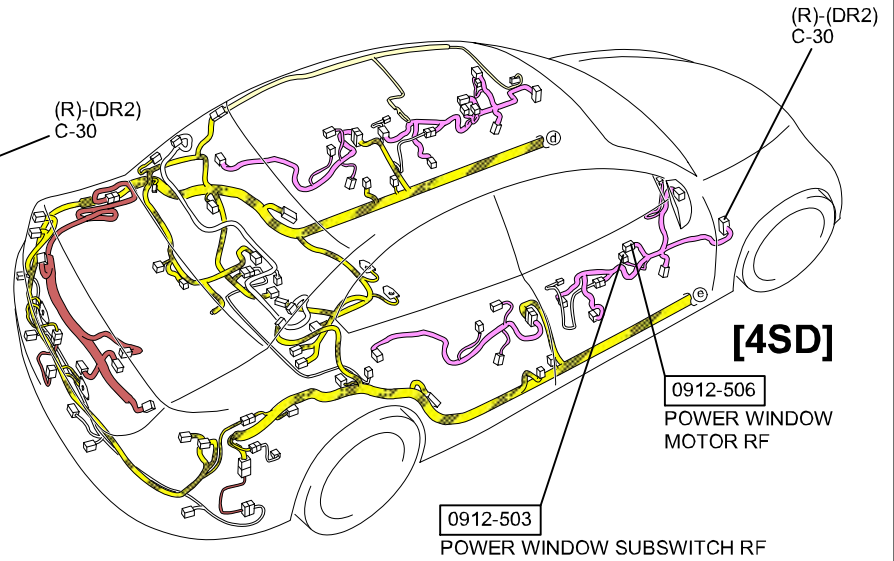
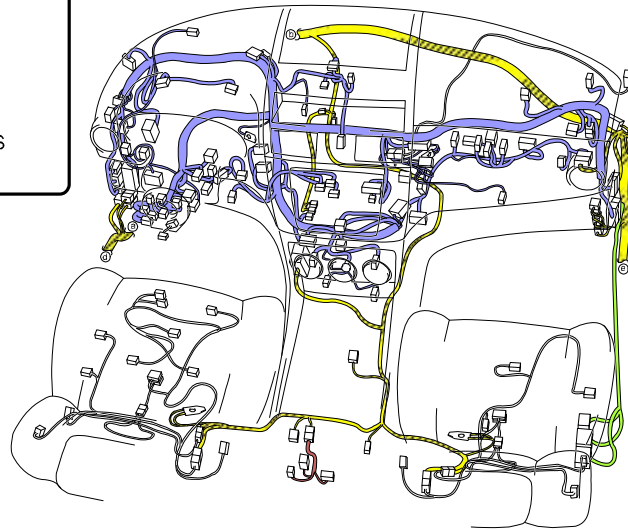

C-30
REAR HARNESS-DOOR NO.2 HARNESS

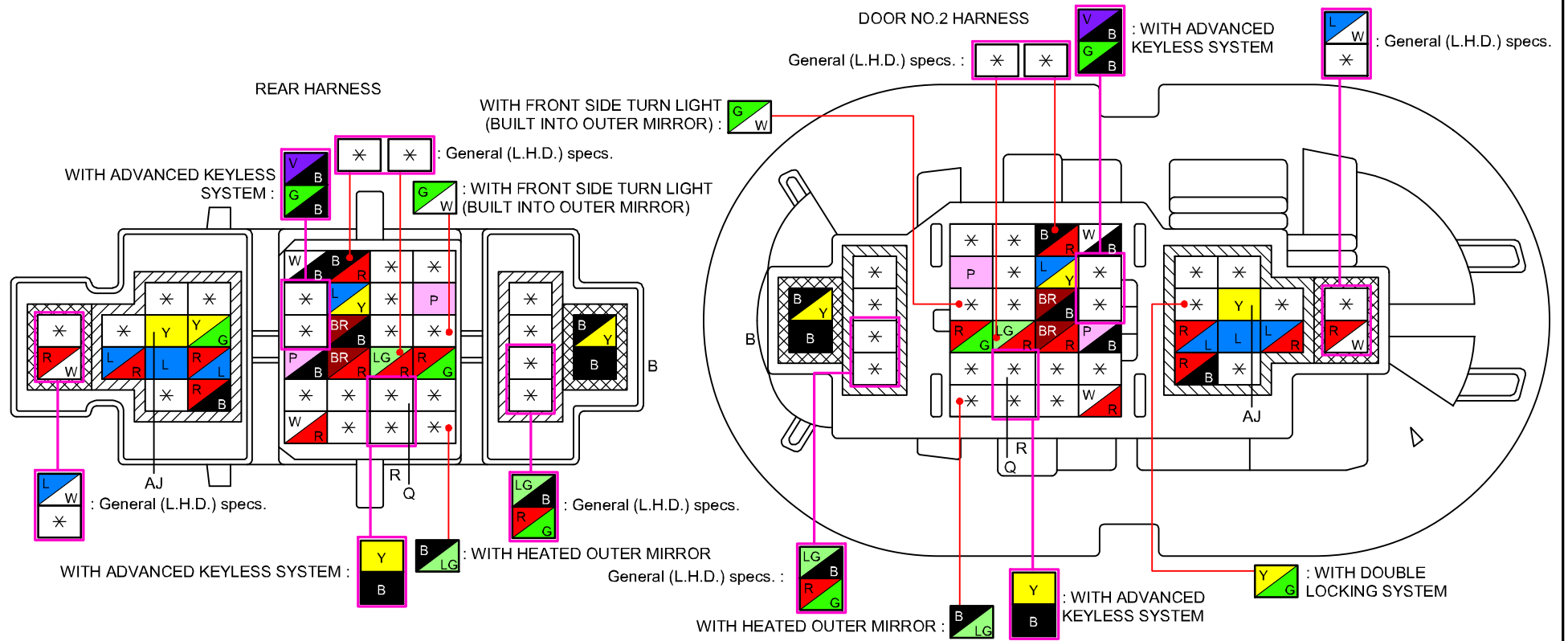

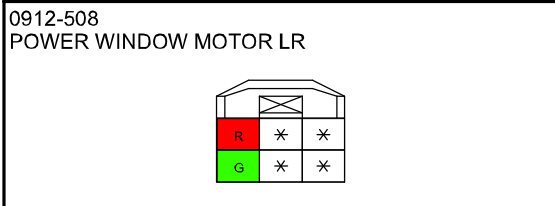
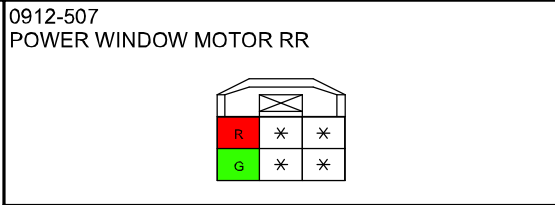
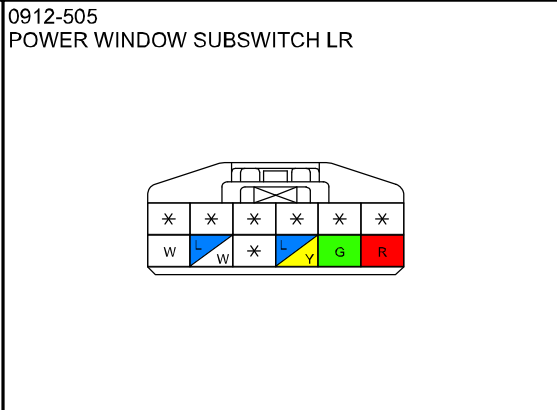
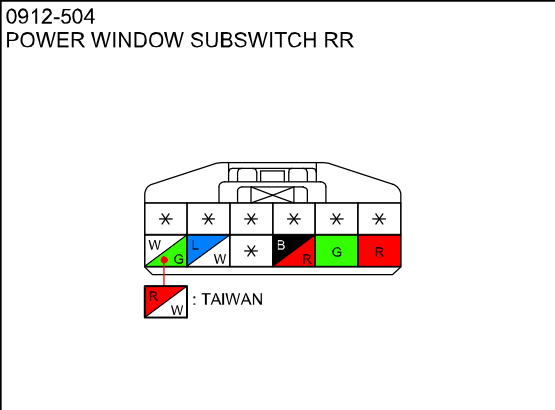
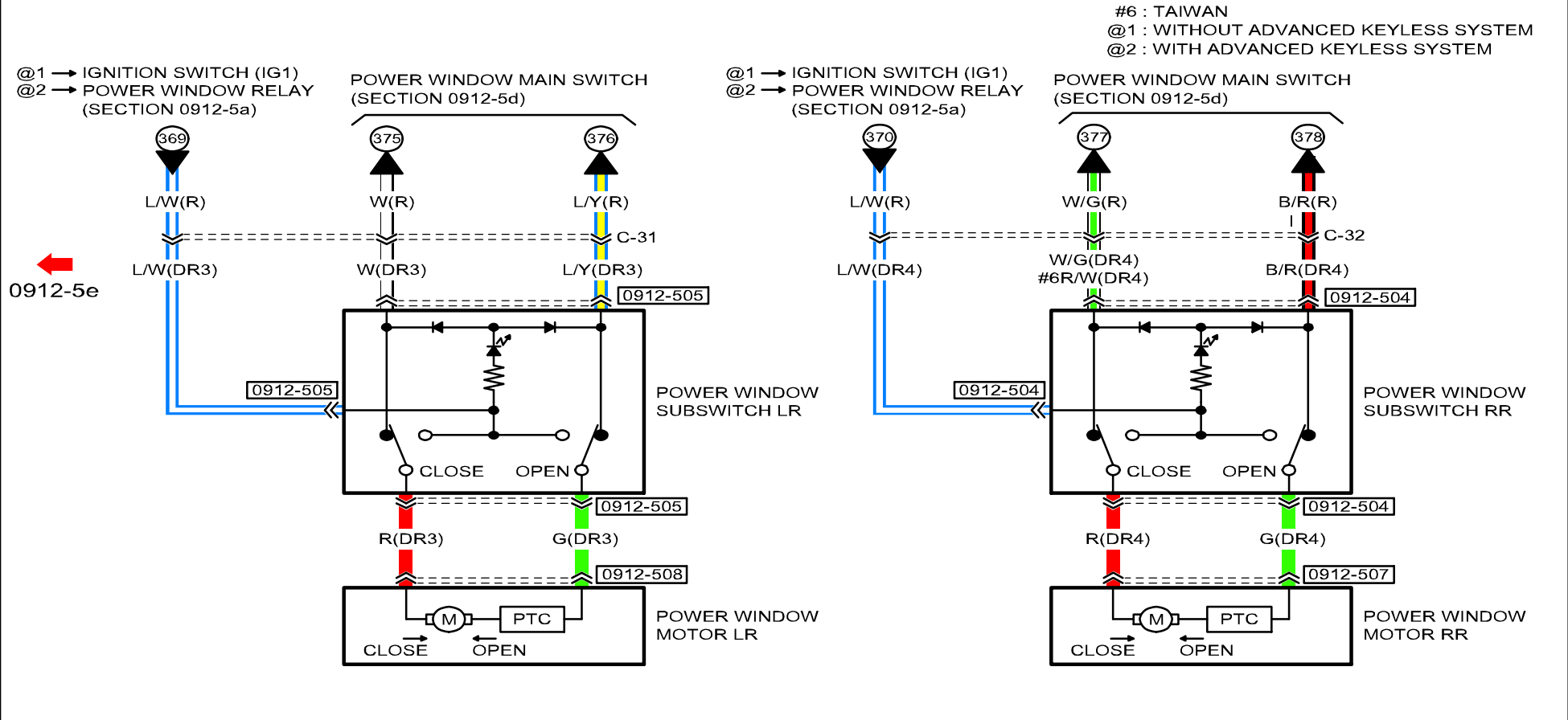

POWER WINDOW SYSTEM (General (L.H.D.) specs.)

0912-5f

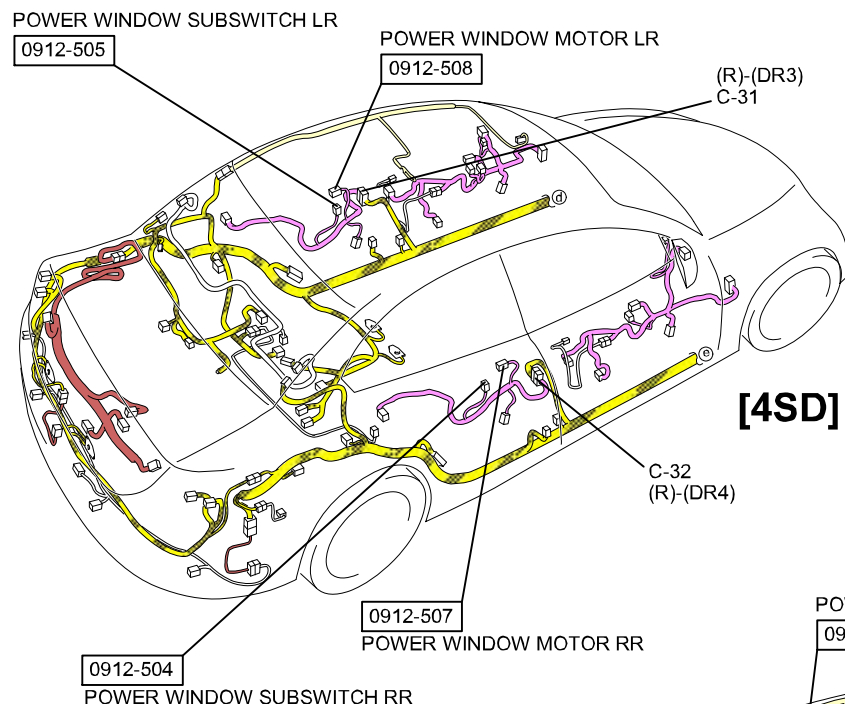

[4SD]

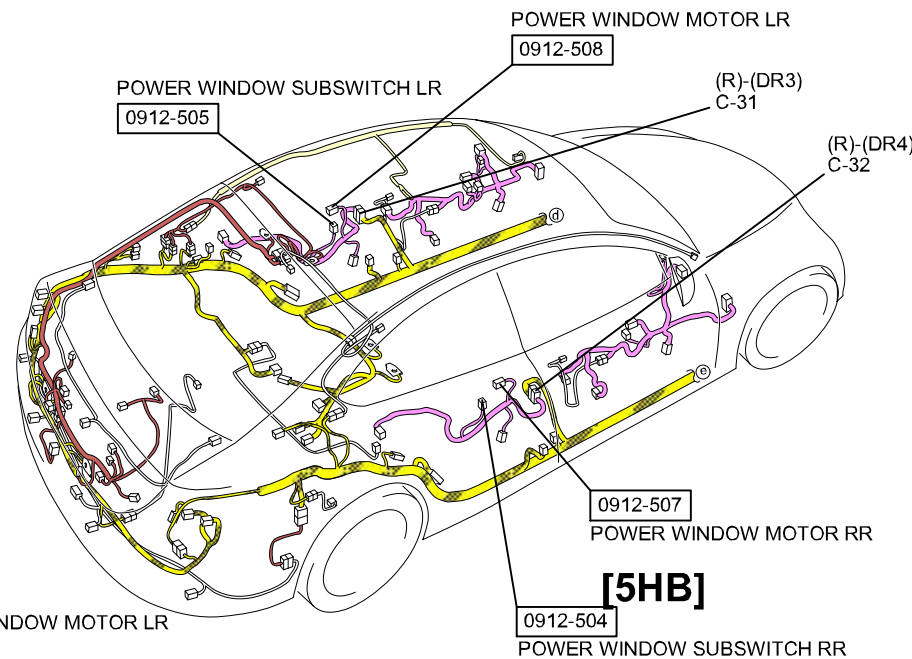

[5HB]

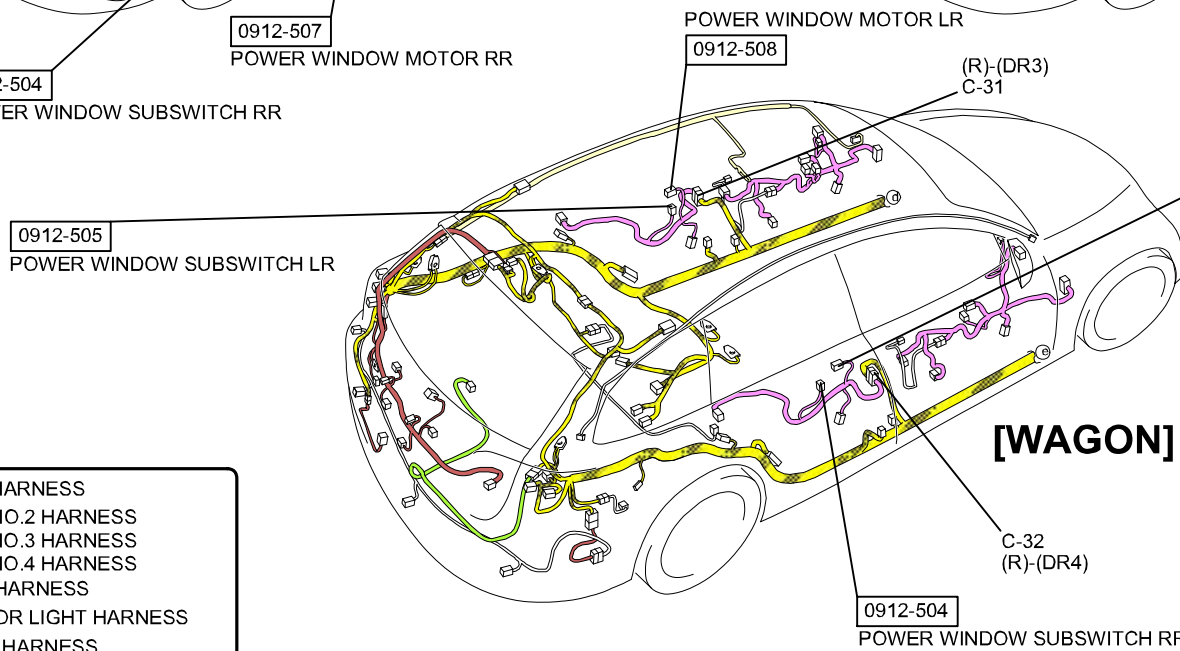

[WAGON]

- : REAR HARNESS
- : REAR NO.2 HARNESS
- : REAR NO.3 HARNESS
- : REAR NO.4 HARNESS
- : DOOR HARNESS
- : INTERIOR LIGHT HARNESS
- : FLOOR HARNESS

C-31
 REAR HARNESS-DOOR NO.3 HARNESS
 REAR HARNESS

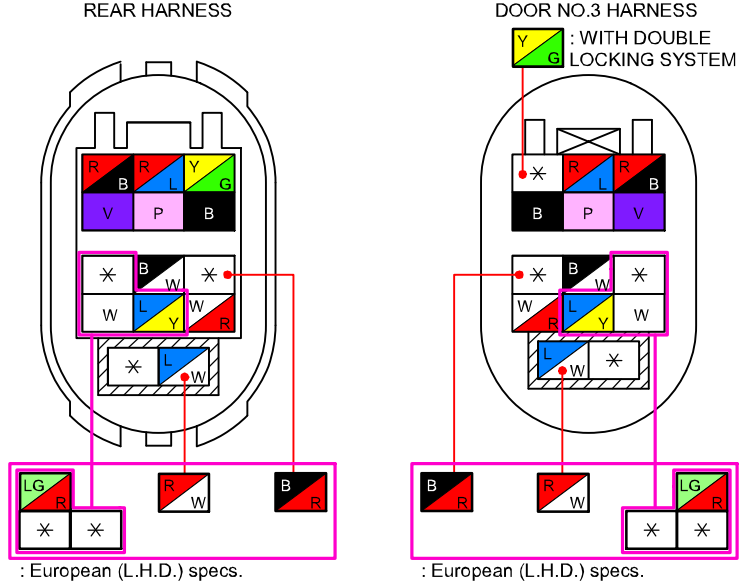

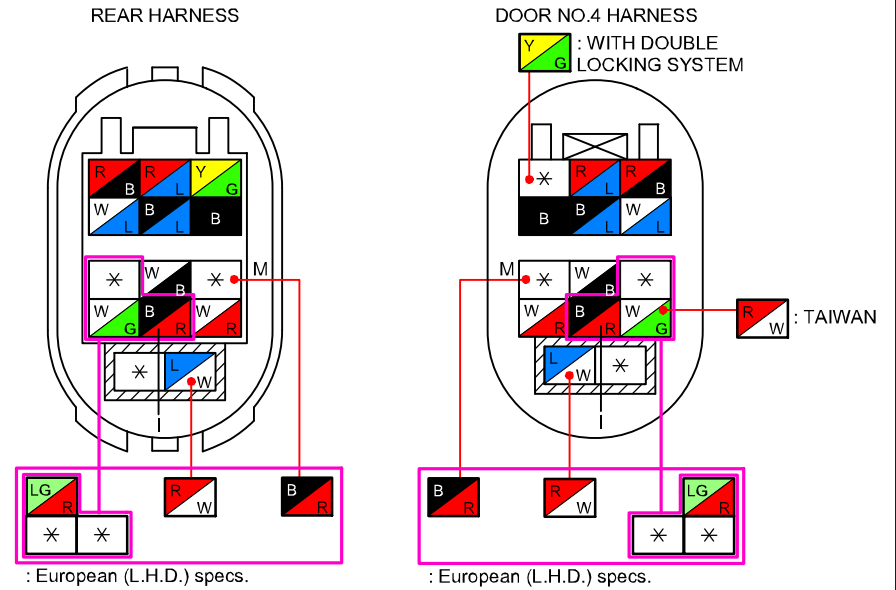

C-32
 REAR HARNESS-DOOR NO.4 HARNESS
 REAR HARNESS

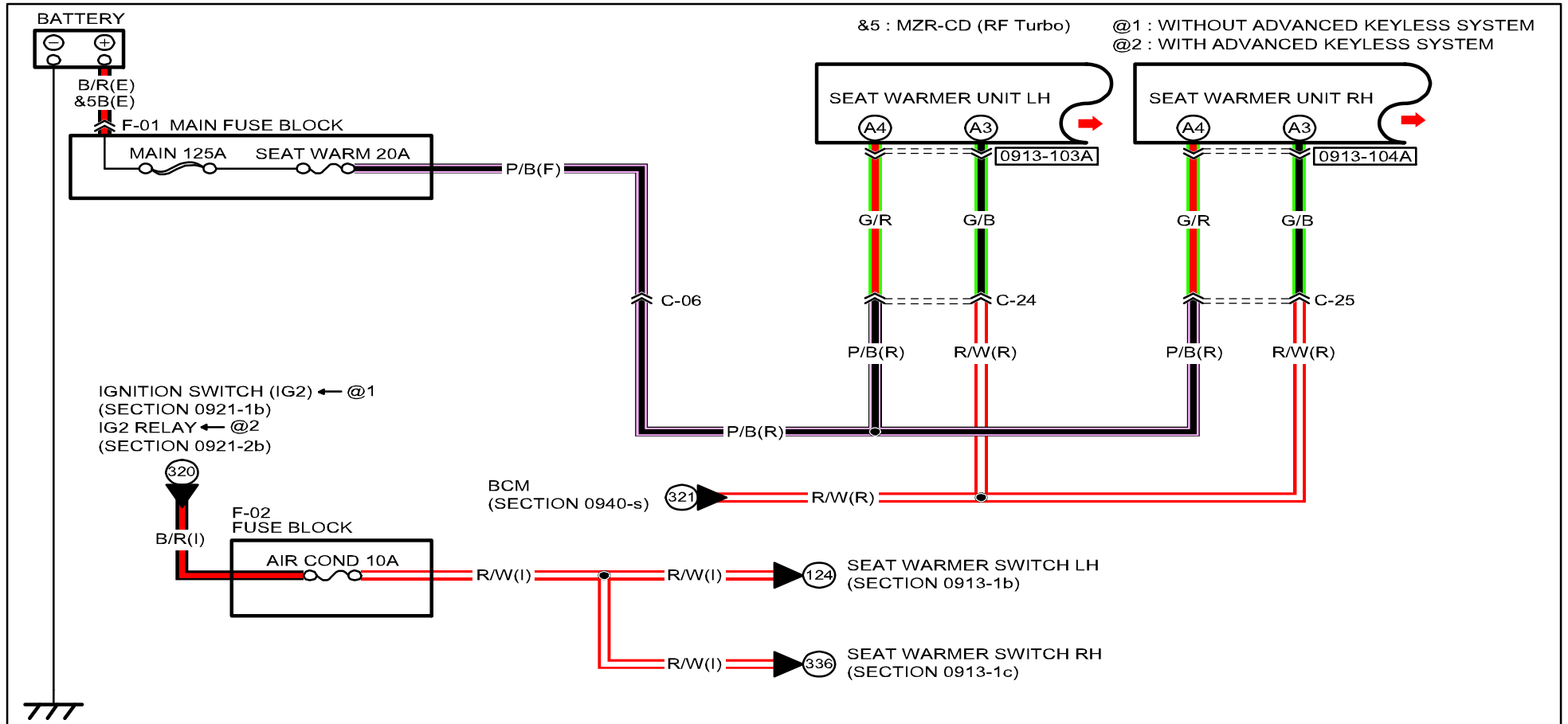

SEAT WARMER

0913-1a



<p>0913-103A SEAT WARMER UNIT LH</p> 	<p>0913-104A SEAT WARMER UNIT RH</p> 			

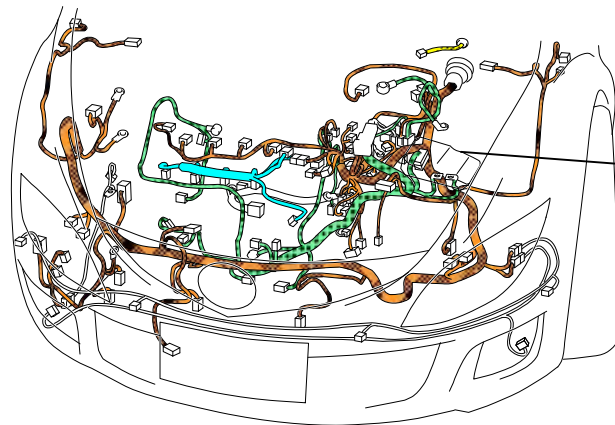

F-01
MAIN FUSE BLOCK
(REFER TO 00F SECTION)

[EXCEPT MZR-CD (RF Turbo)]

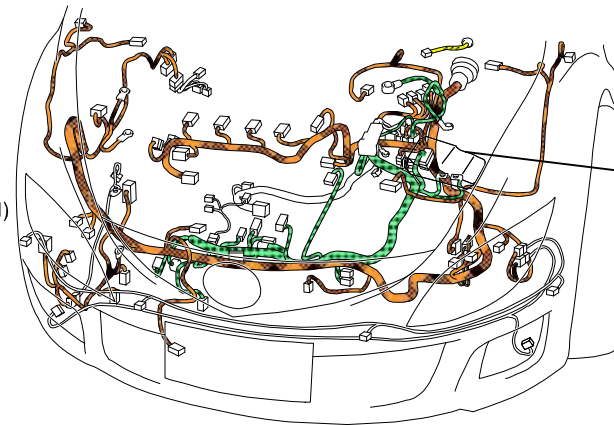

F-01
MAIN FUSE BLOCK
(REFER TO 00F SECTION)

[MZR-CD (RF Turbo)]

[BLUE]
(F)-(R)
C-06

- : FRONT HARNESS
- : ENGINE HARNESS
- : INJECTION HARNESS
- : REAR HARNESS
- : REAR NO.5 HARNESS
- : INSTRUMENT PANEL HARNESS
- : FLOOR HARNESS
- : INTERIOR LIGHT NO.2 HARNESS

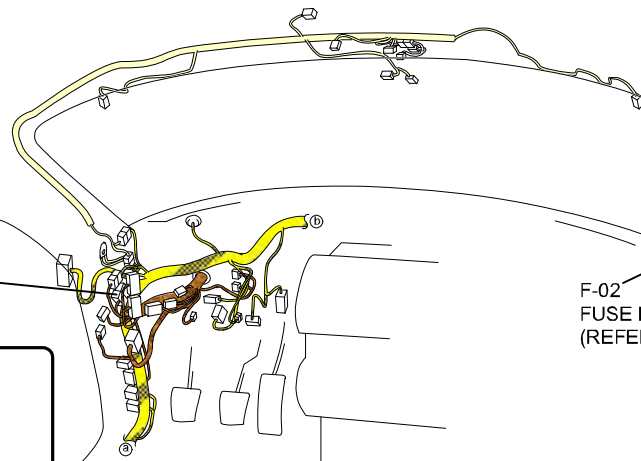

F-02
FUSE BLOCK
(REFER TO 00F SECTION)

0913-103A
SEAT WARMER UNIT LH

C-24
(R)-SHORT CORD

C-25
(R)-SHORT CORD

0913-104A
SEAT WARMER UNIT RH

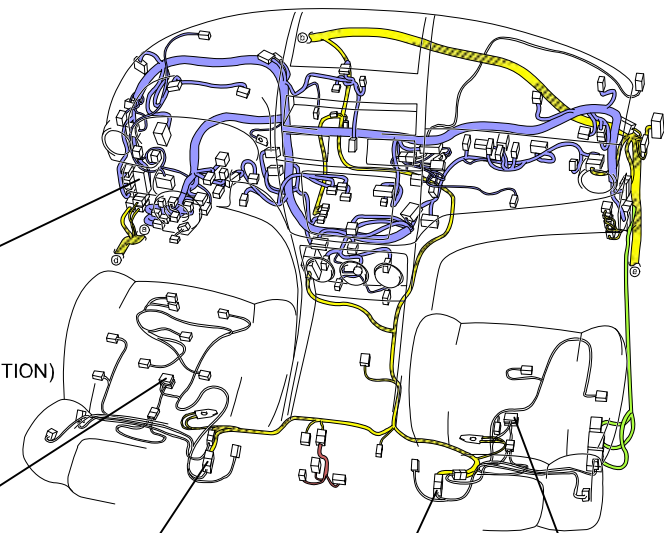

SEAT WARMER

0913-1b

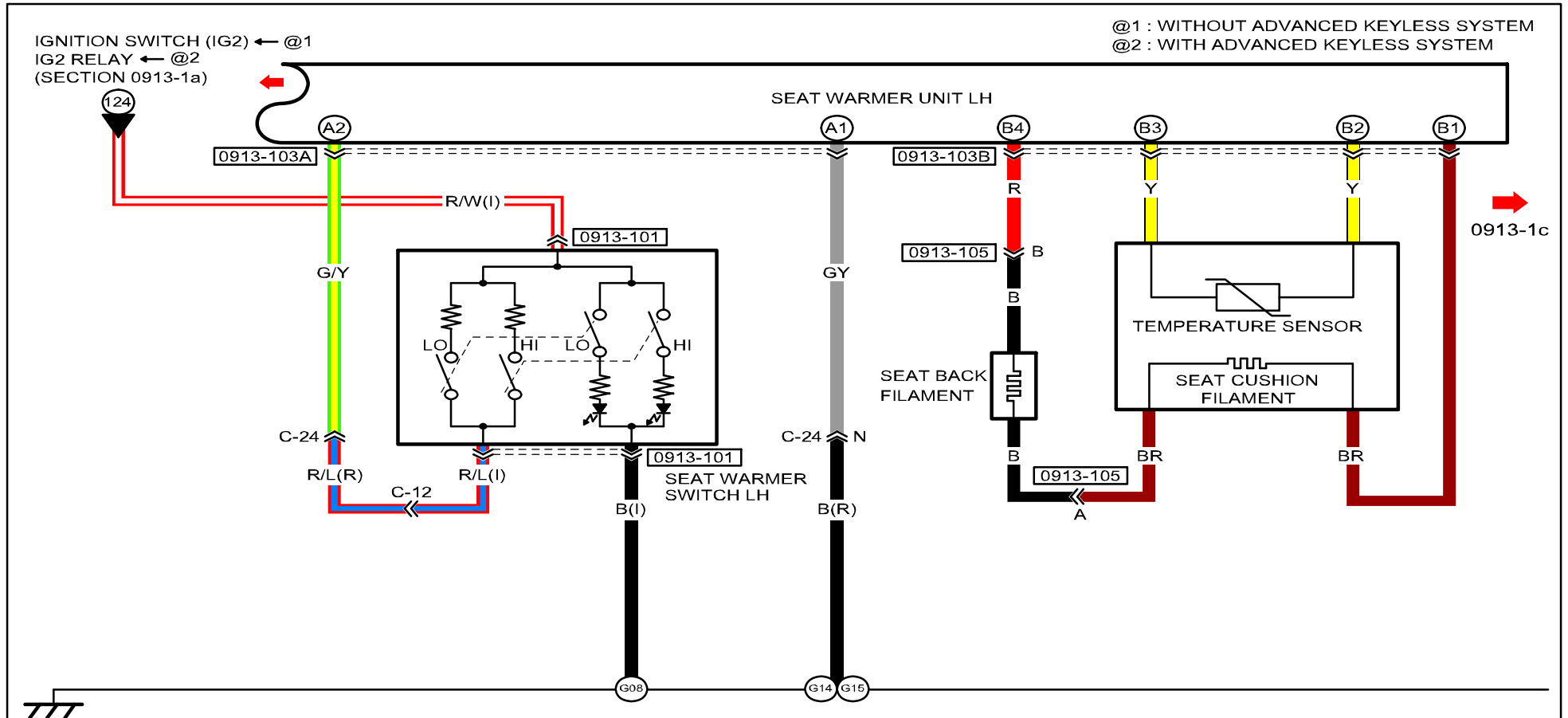

<p>0913-101 SEAT WARMER SWITCH LH / SEAT WARMER SWITCH ILLUMINATION LH</p>	<p>0913-103A SEAT WARMER UNIT LH</p>	<p>0913-103B SEAT WARMER UNIT LH</p>	<p>0913-105 SHORT CORD-SHORT CORD</p>	

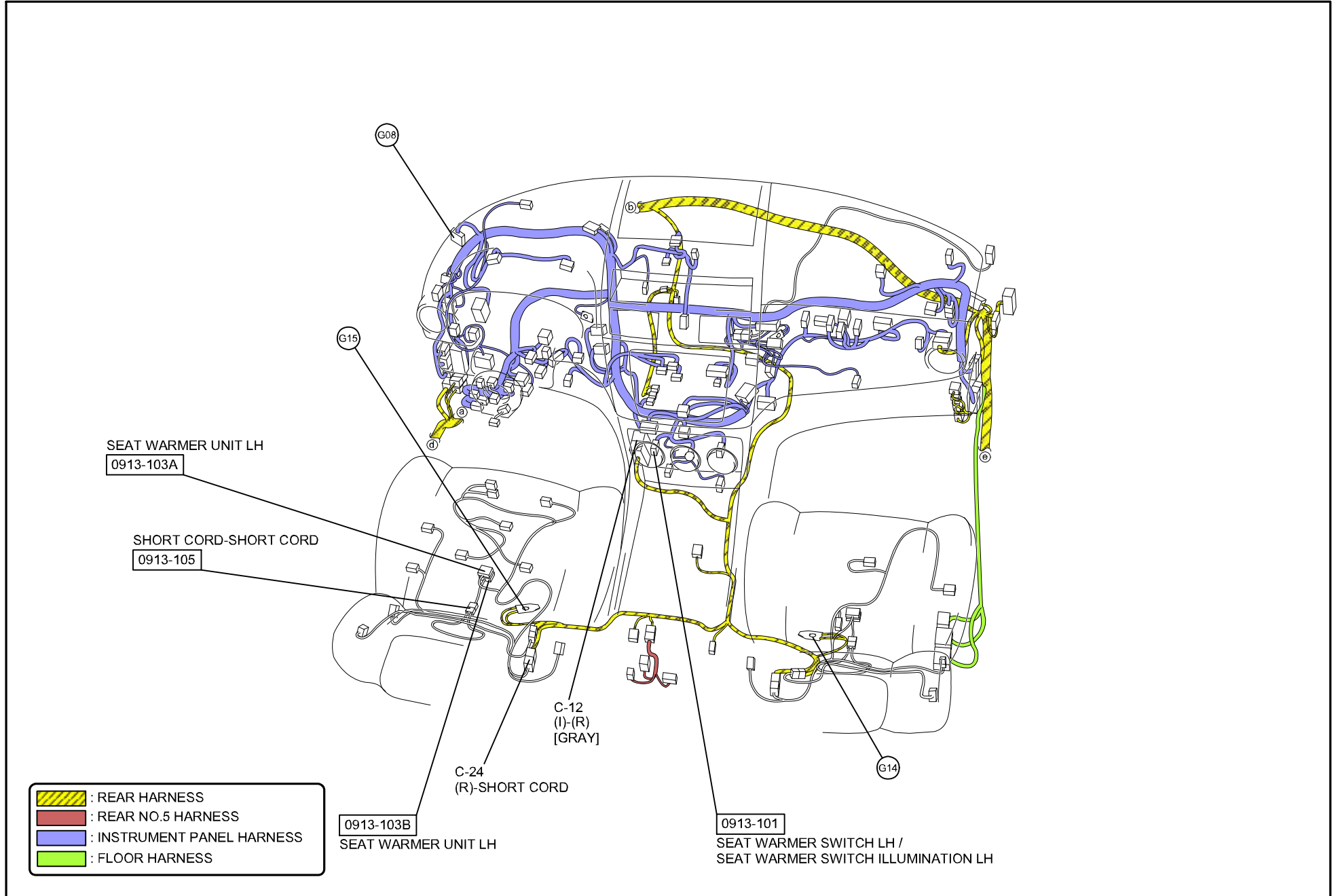

SEAT WARMER

0913-1b

C-12 INSTRUMENT PANEL HARNESS-REAR HARNESS

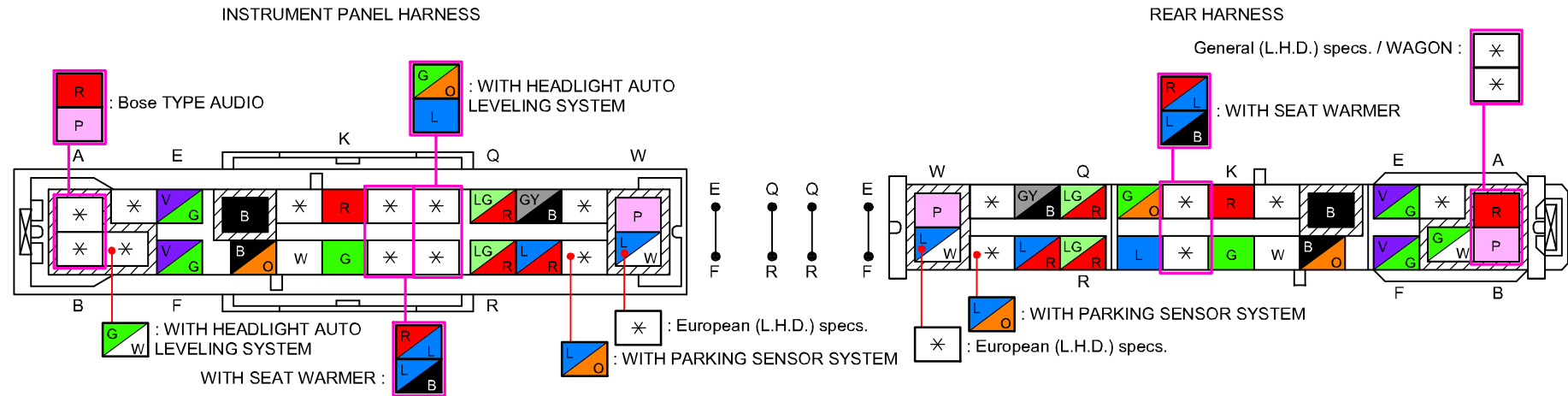

C-24 REAR HARNESS-SHORT CORD

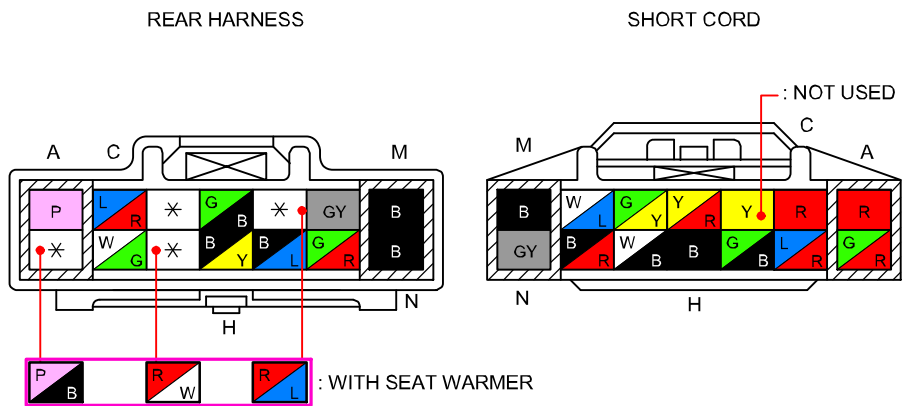

SEAT WARMER

0913-1c

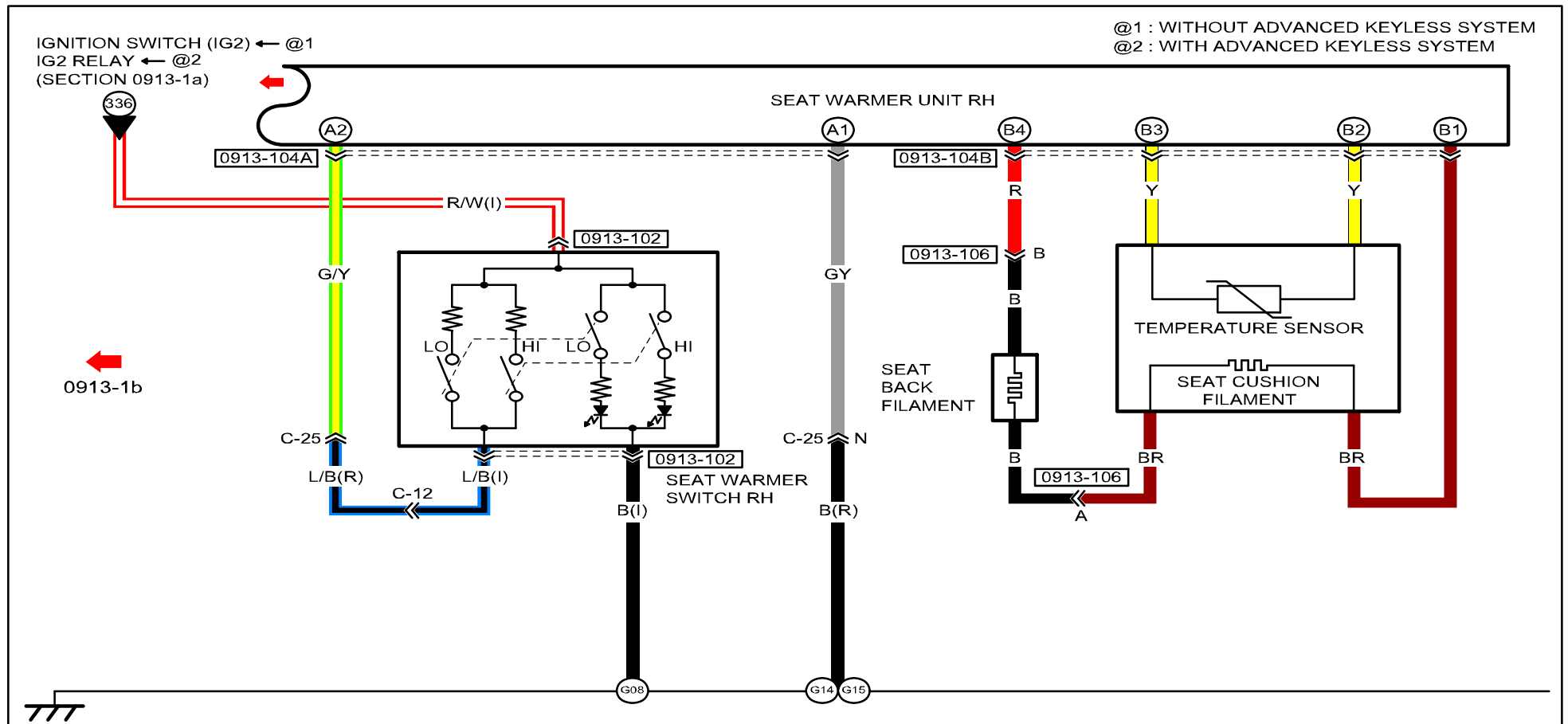

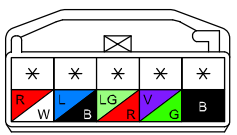
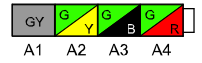
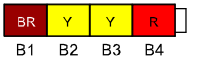
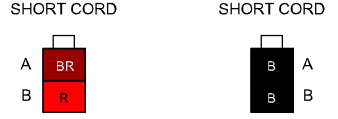
<p>0913-102 SEAT WARMER SWITCH RH / SEAT WARMER SWITCH ILLUMINATION RH</p> 	<p>0913-104A SEAT WARMER UNIT RH</p> 	<p>0913-104B SEAT WARMER UNIT RH</p> 	<p>0913-106 SHORT CORD-SHORT CORD</p> 	

SEAT WARMER

0913-1c

C-12 INSTRUMENT PANEL HARNESS-REAR HARNESS

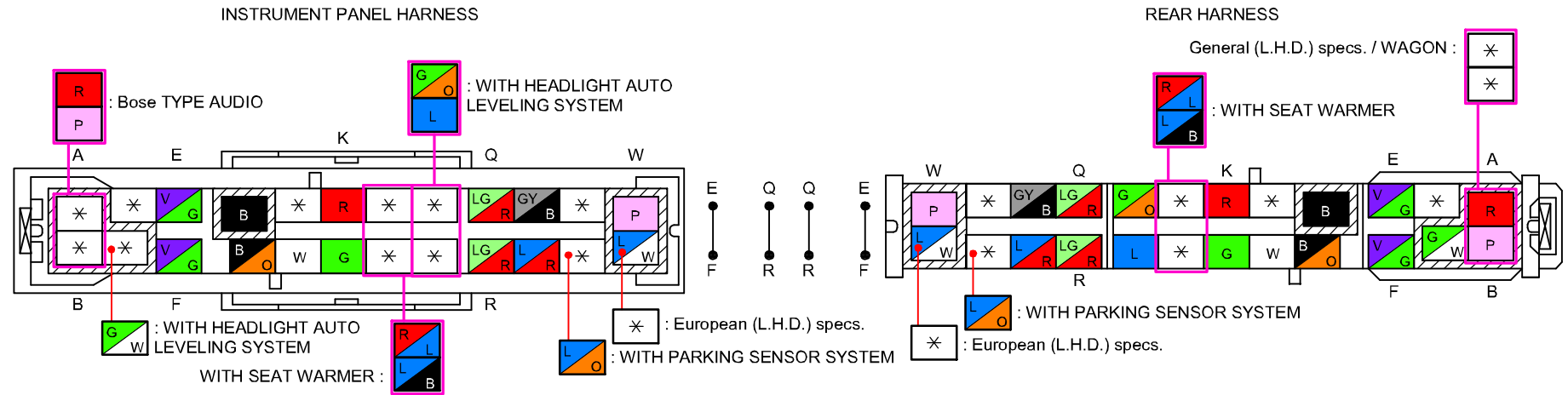

C-25 REAR HARNESS-SHORT CORD

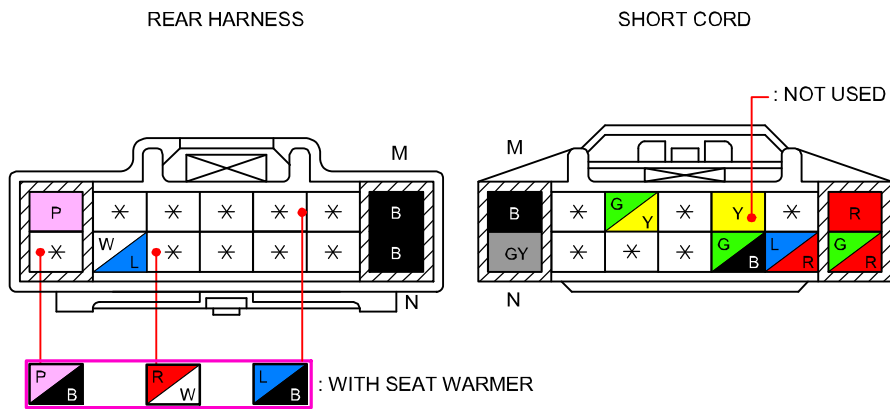

MEMORY POWER SEAT

0913-2a

&5 : MZR-CD (RF Turbo)

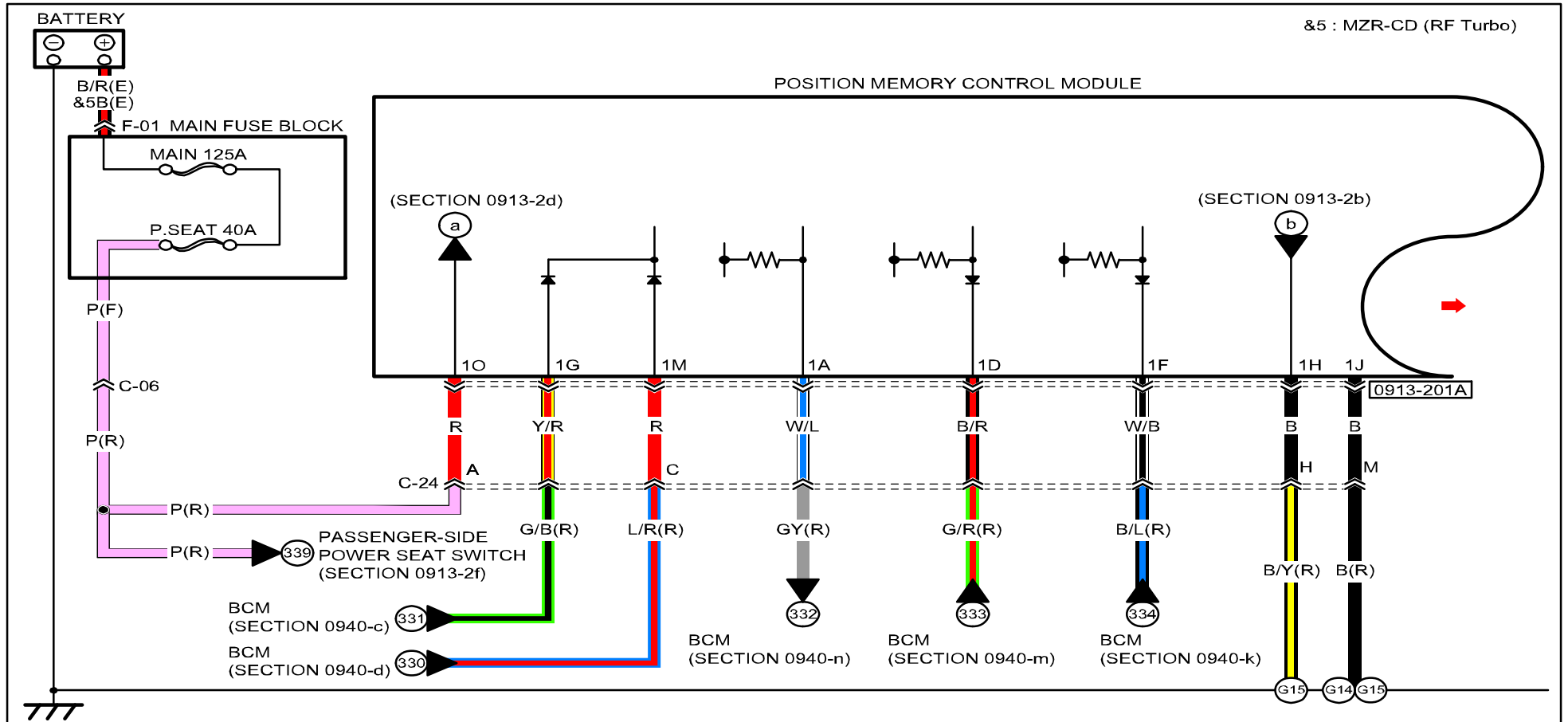

<p>0913-201A POSITION MEMORY CONTROL MODULE</p>					

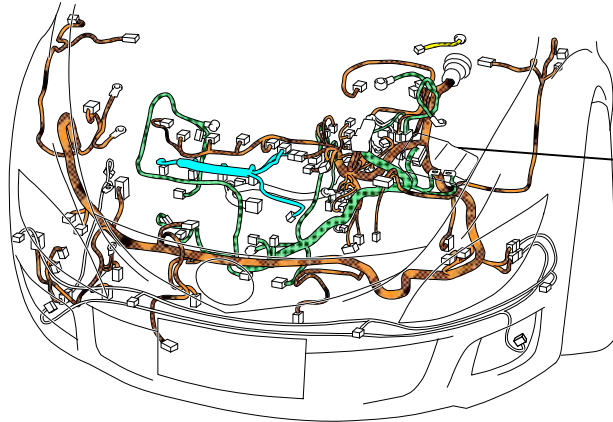

F-01
MAIN FUSE BLOCK
(REFER TO 00F SECTION)

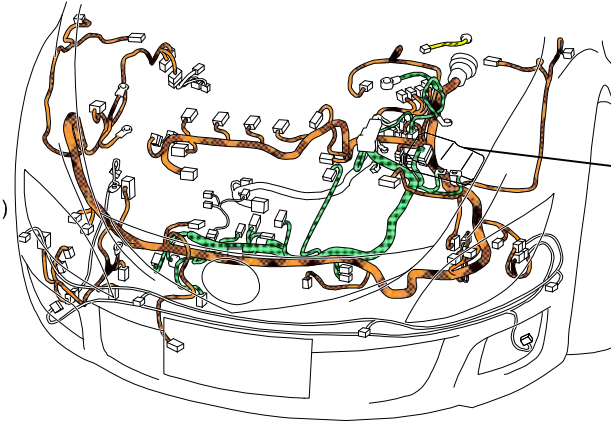

F-01
MAIN FUSE BLOCK
(REFER TO 00F SECTION)





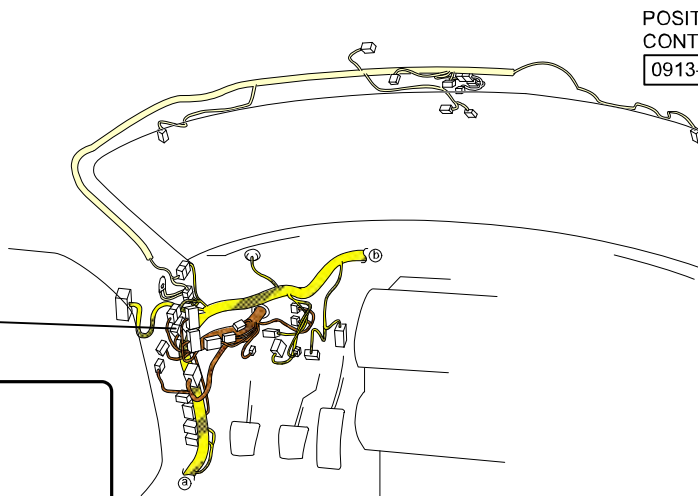



[EXCEPT MZR-CD (RF Turbo)]

[MZR-CD (RF Turbo)]



POSITION MEMORY
CONTROL MODULE
0913-201A

[BLUE]
(F)-(R)
C-06

-  : FRONT HARNESS
-  : ENGINE HARNESS
-  : INJECTION HARNESS
-  : REAR HARNESS
-  : REAR NO.5 HARNESS
-  : INSTRUMENT PANEL HARNESS
-  : FLOOR HARNESS
-  : INTERIOR LIGHT NO.2 HARNESS

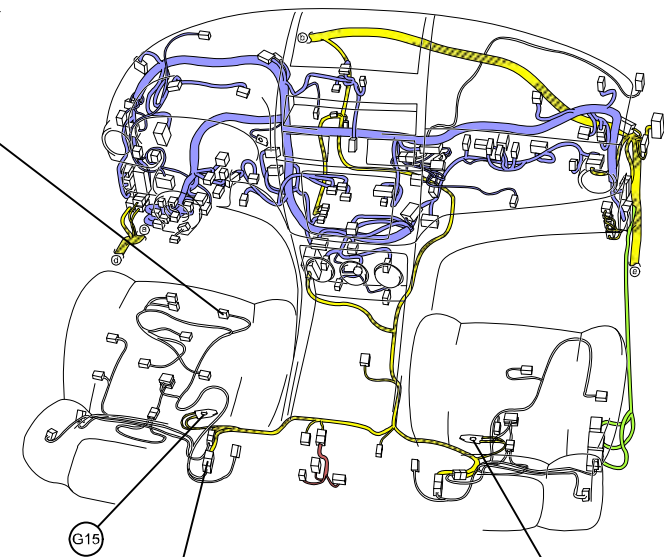

C-24
(R)-SHORT CORD

G15

G14

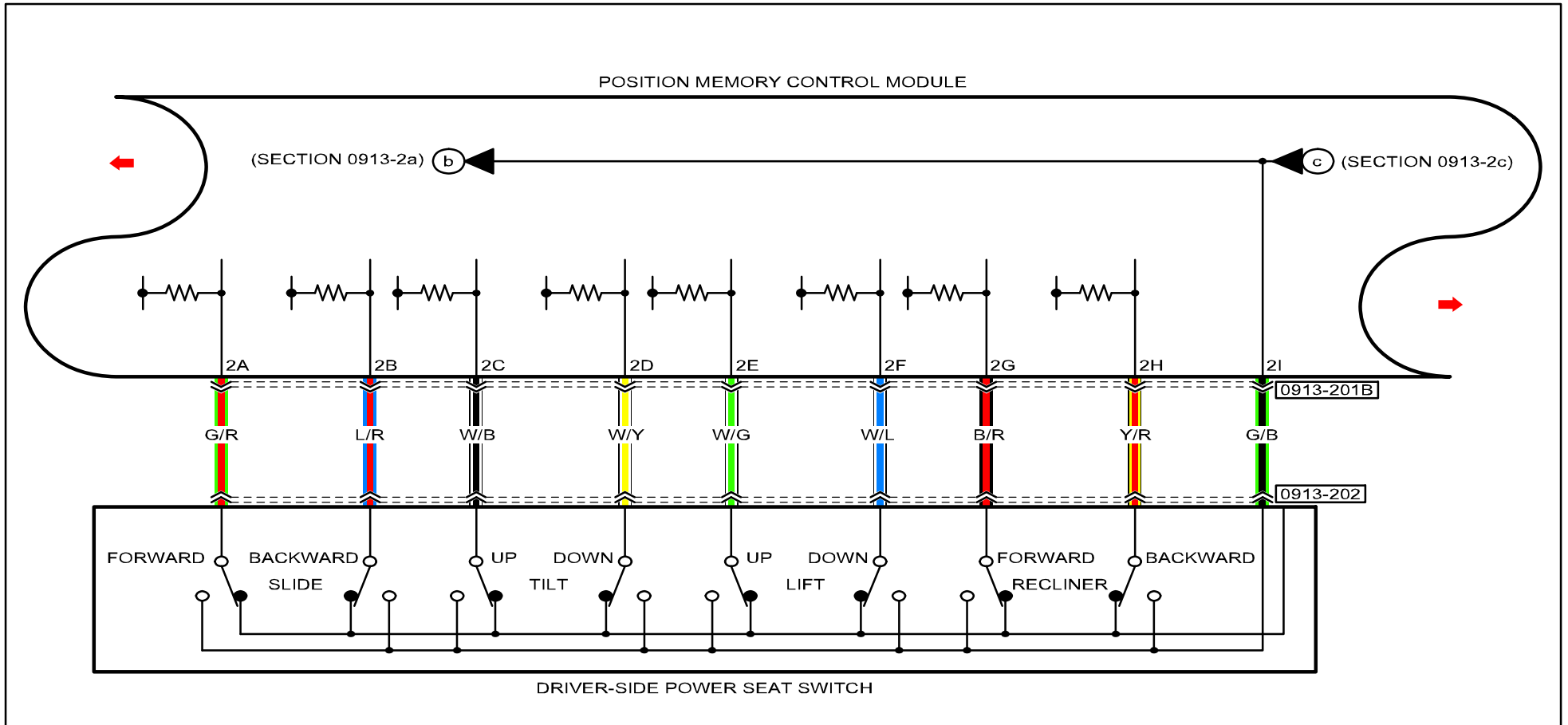



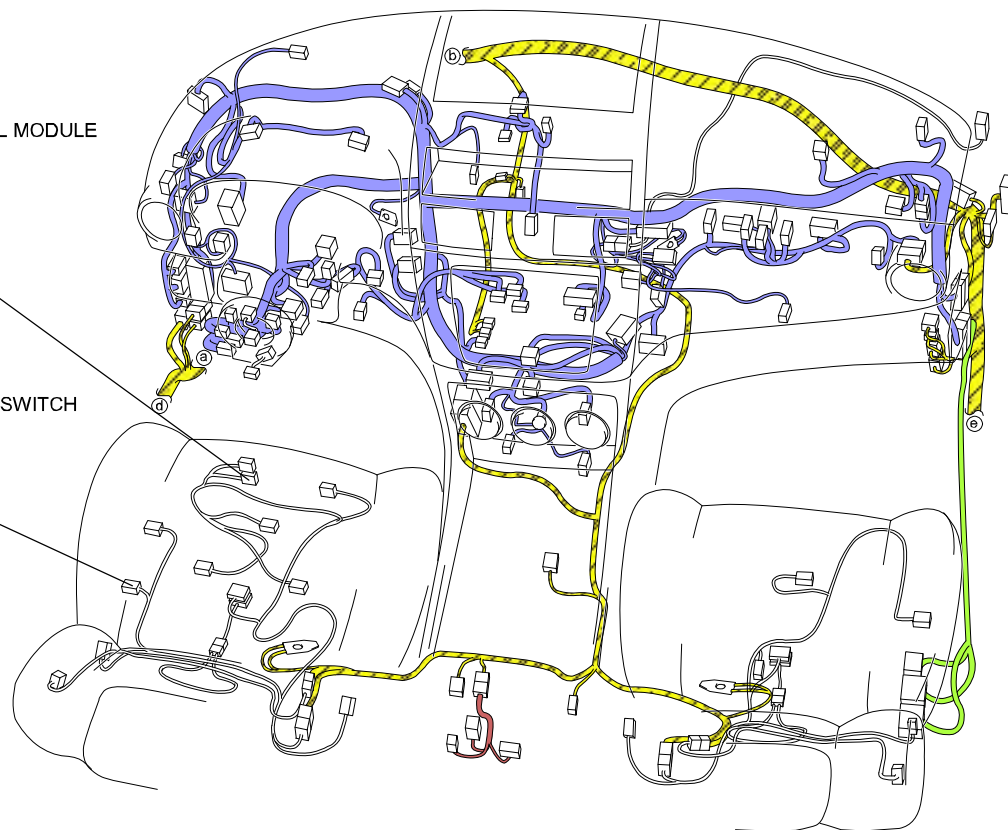

<p>0913-201B POSITION MEMORY CONTROL MODULE</p>	<p>0913-202 DRIVER-SIDE POWER SEAT SWITCH</p>			

POSITION MEMORY CONTROL MODULE
0913-201B

DRIVER-SIDE POWER SEAT SWITCH
0913-202



-  : REAR HARNESS
-  : REAR NO.5 HARNESS
-  : INSTRUMENT PANEL HARNESS
-  : FLOOR HARNESS

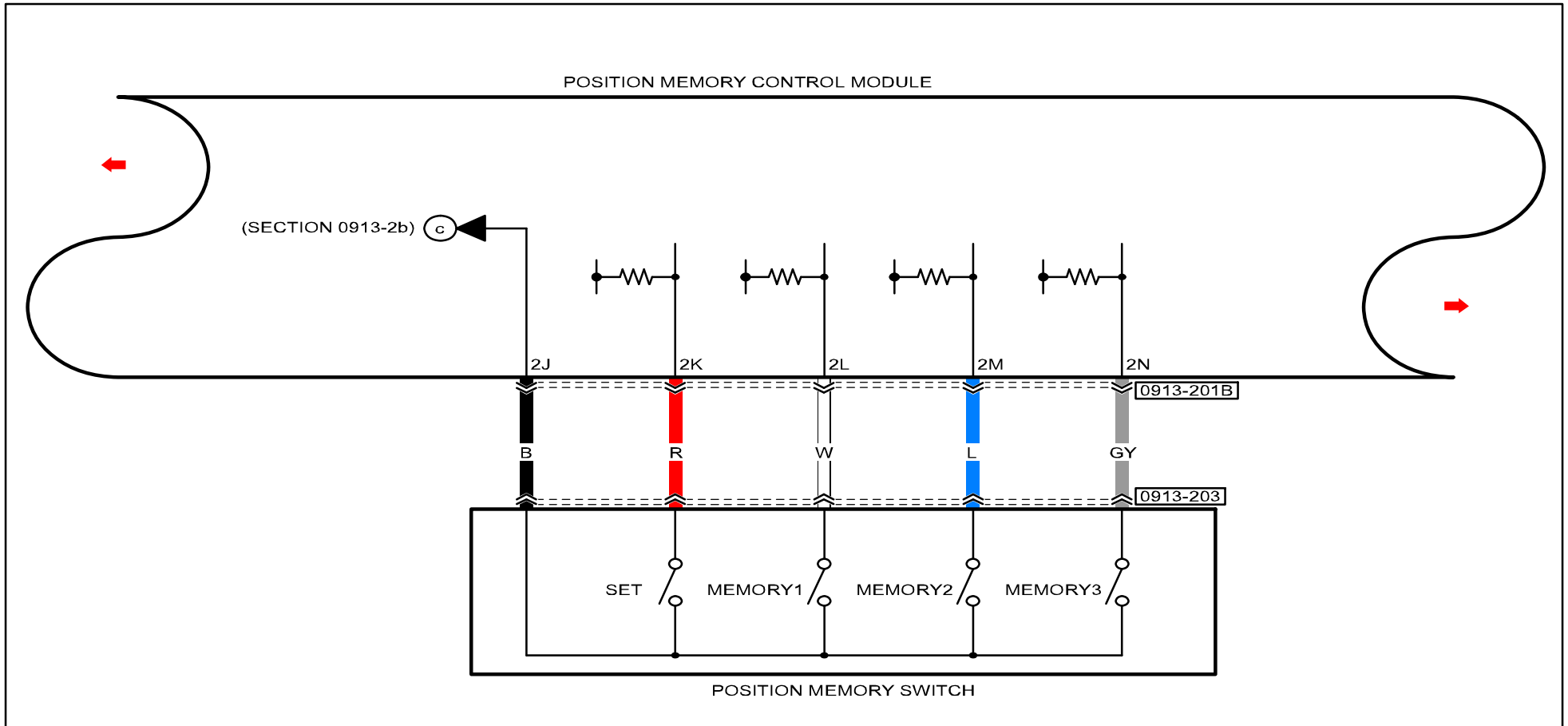



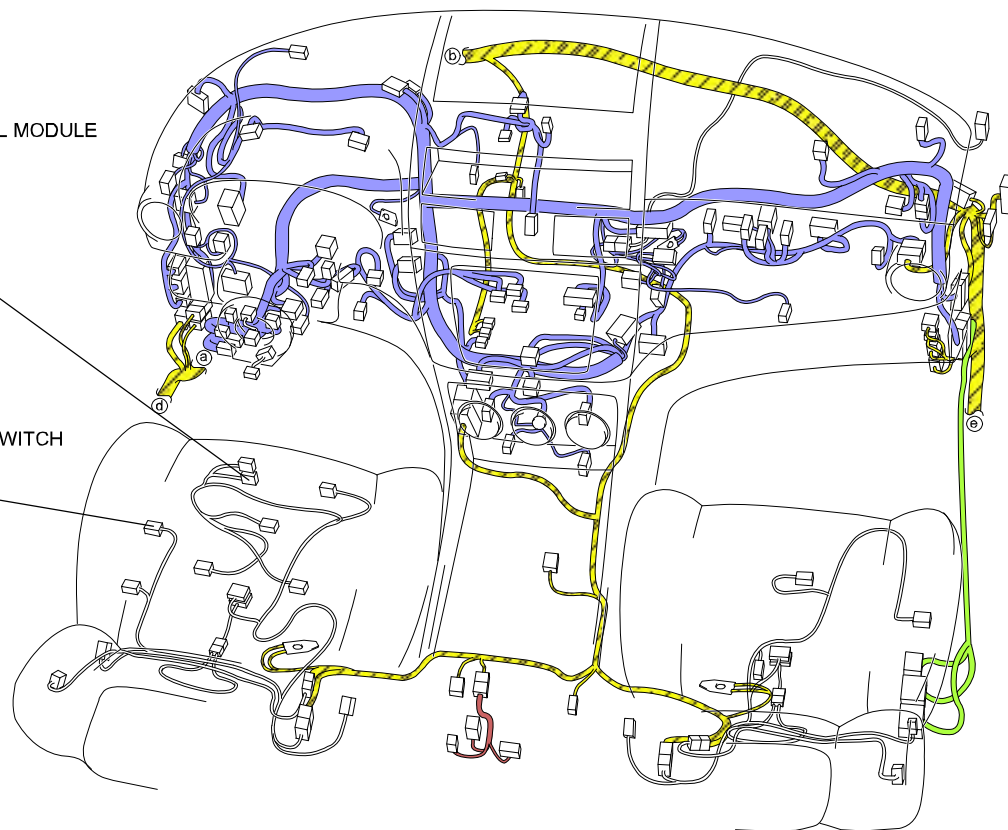

<p>0913-201B POSITION MEMORY CONTROL MODULE</p>	<p>0913-203 POSITION MEMORY SWITCH</p>	

POSITION MEMORY CONTROL MODULE
0913-201B





POSITION MEMORY SWITCH
0913-203

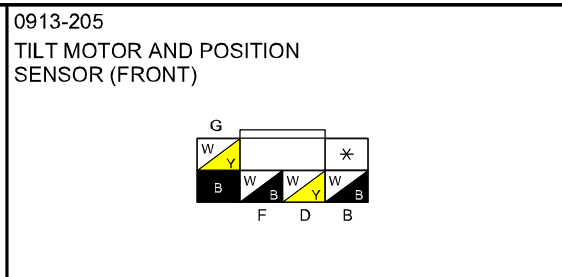
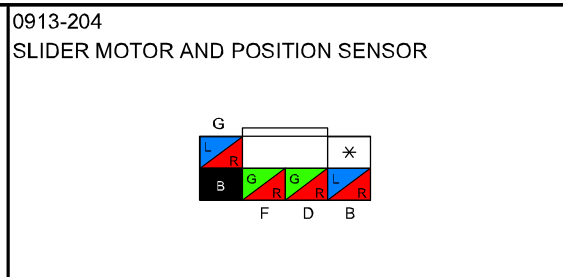
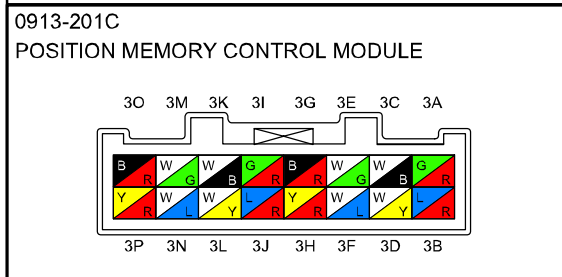
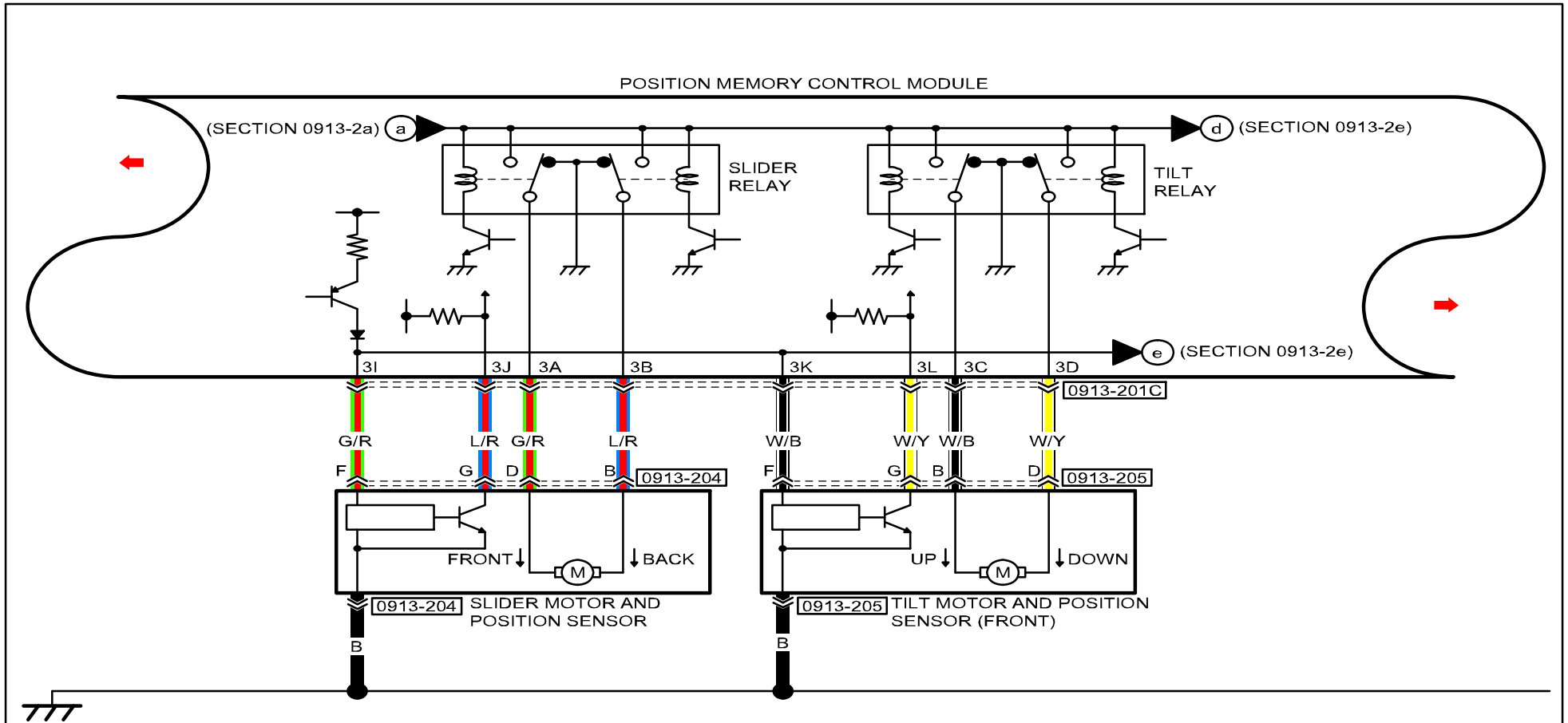

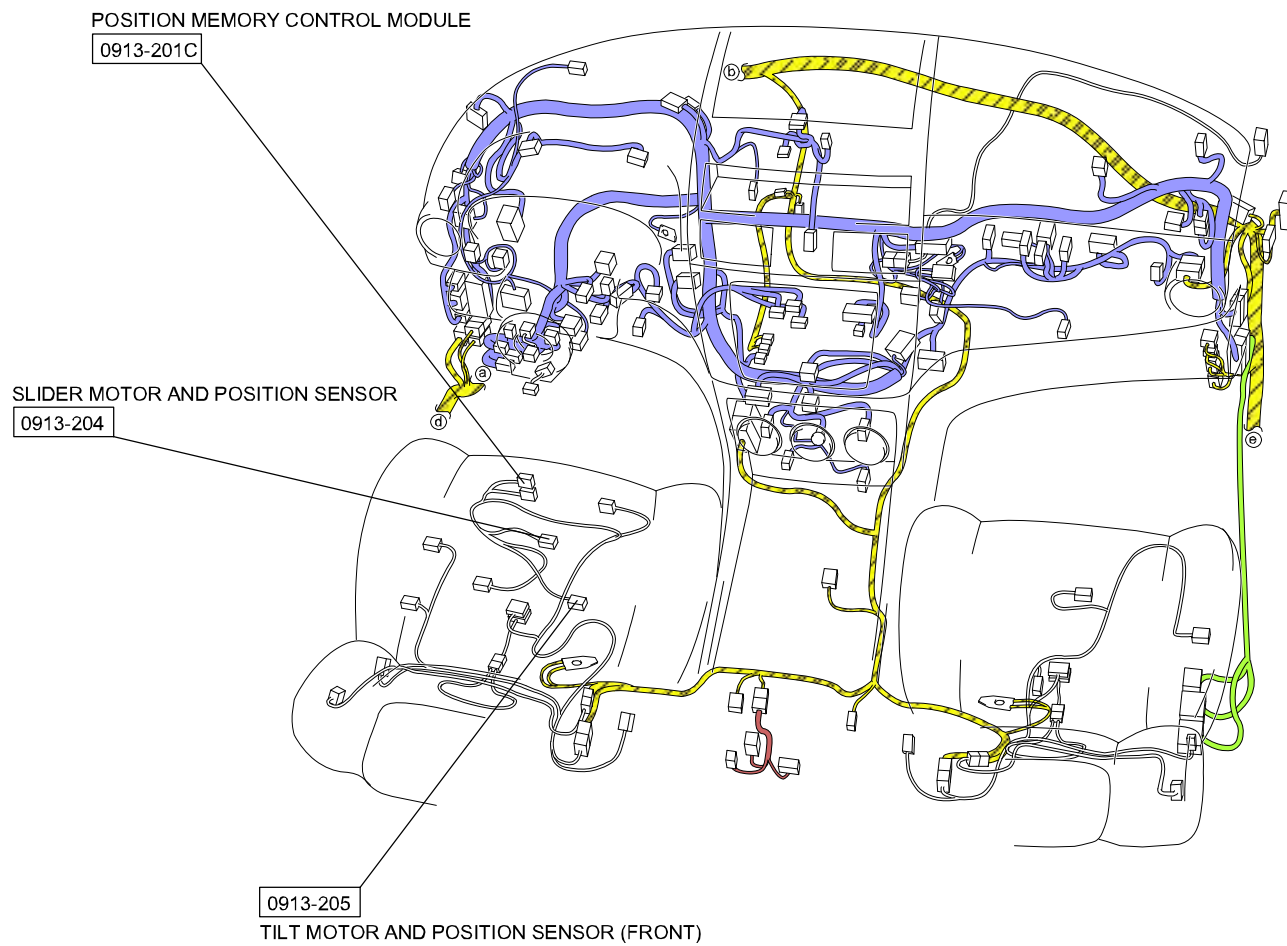
-  : REAR HARNESS
-  : REAR NO.5 HARNESS
-  : INSTRUMENT PANEL HARNESS
-  : FLOOR HARNESS





-  : REAR HARNESS
-  : REAR NO.5 HARNESS
-  : INSTRUMENT PANEL HARNESS
-  : FLOOR HARNESS

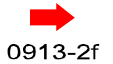

0913-2f

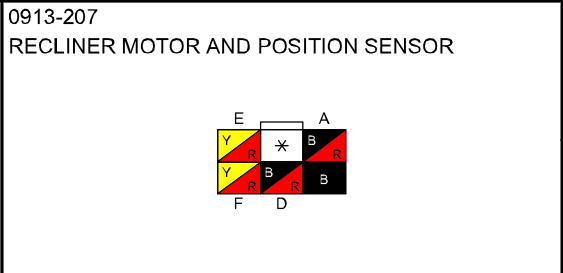
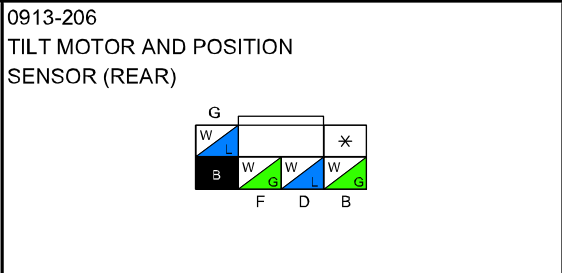
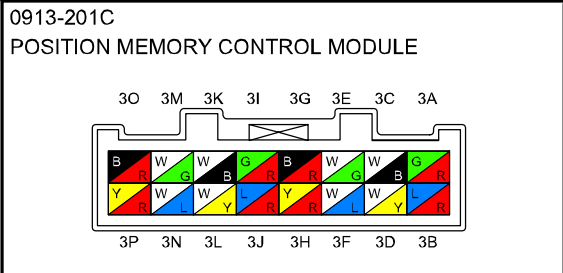
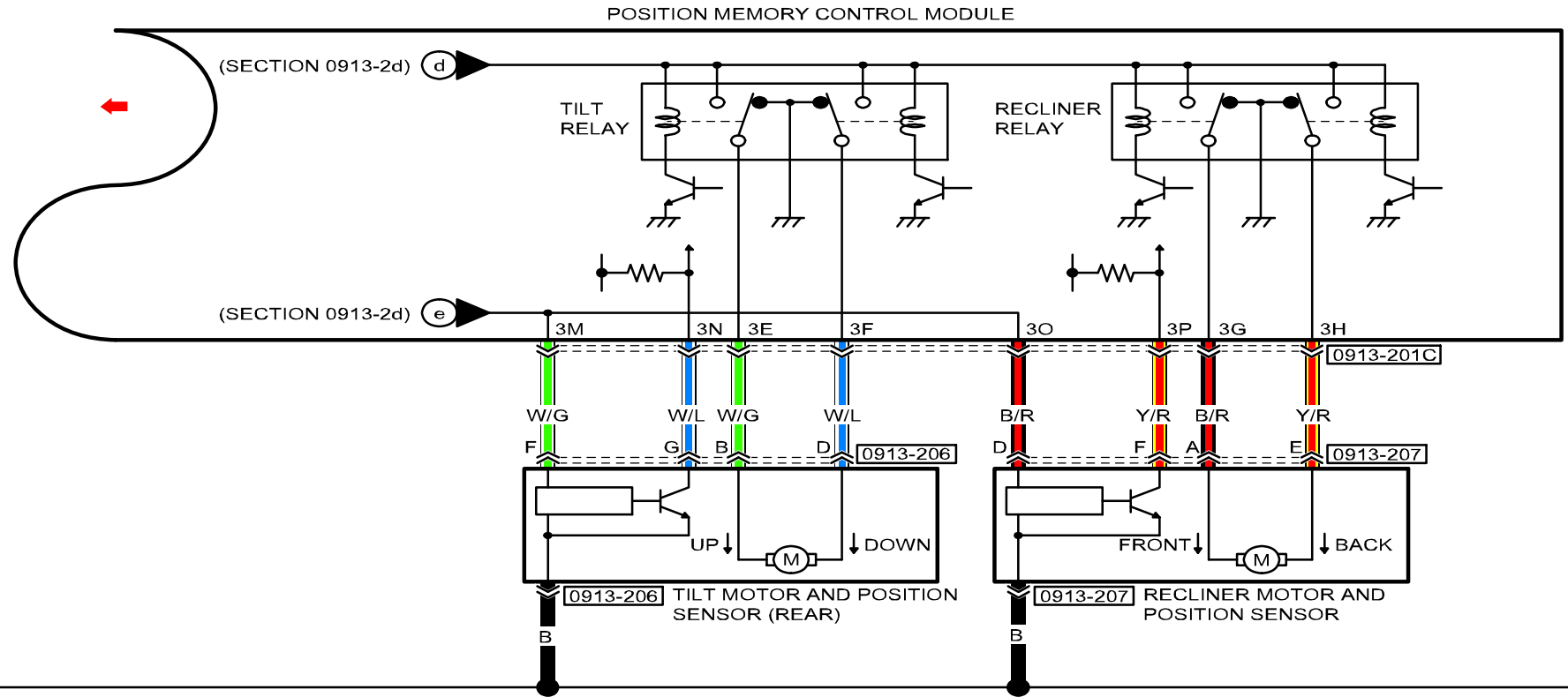





--	--	--	--	--	--

POSITION MEMORY CONTROL MODULE
0913-201C

TILT MOTOR AND POSITION SENSOR (REAR)
0913-206

RECLINER MOTOR AND POSITION SENSOR
0913-207

-  : REAR HARNESS
-  : REAR NO.5 HARNESS
-  : INSTRUMENT PANEL HARNESS
-  : FLOOR HARNESS

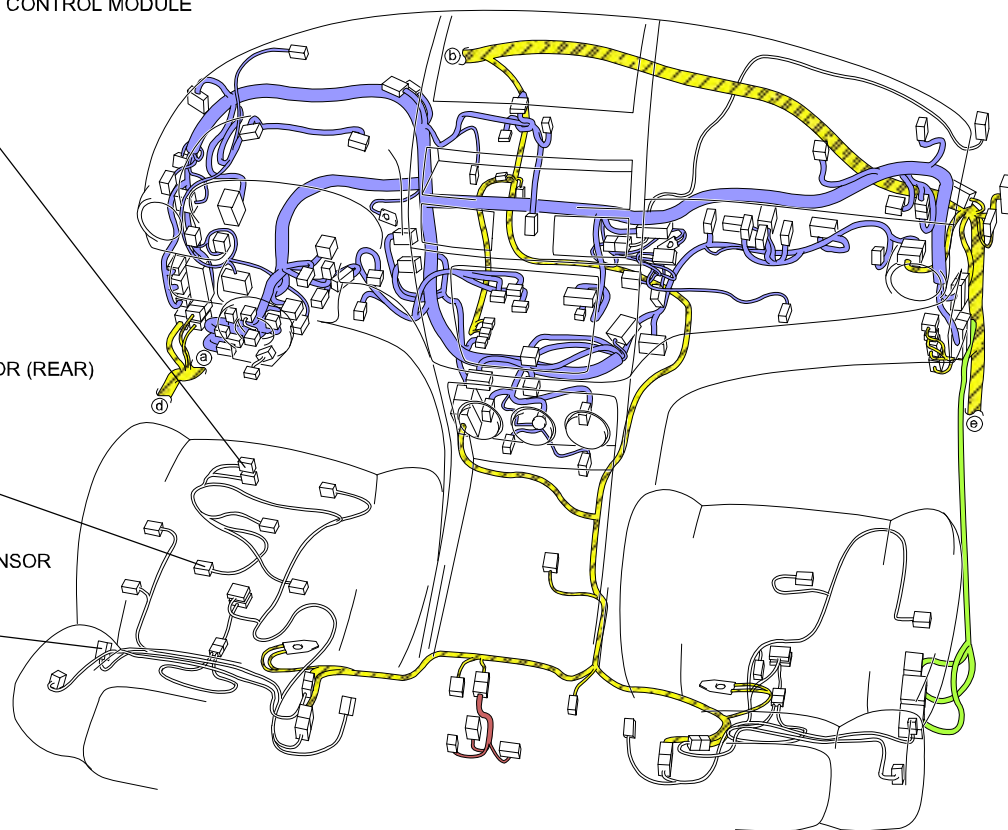

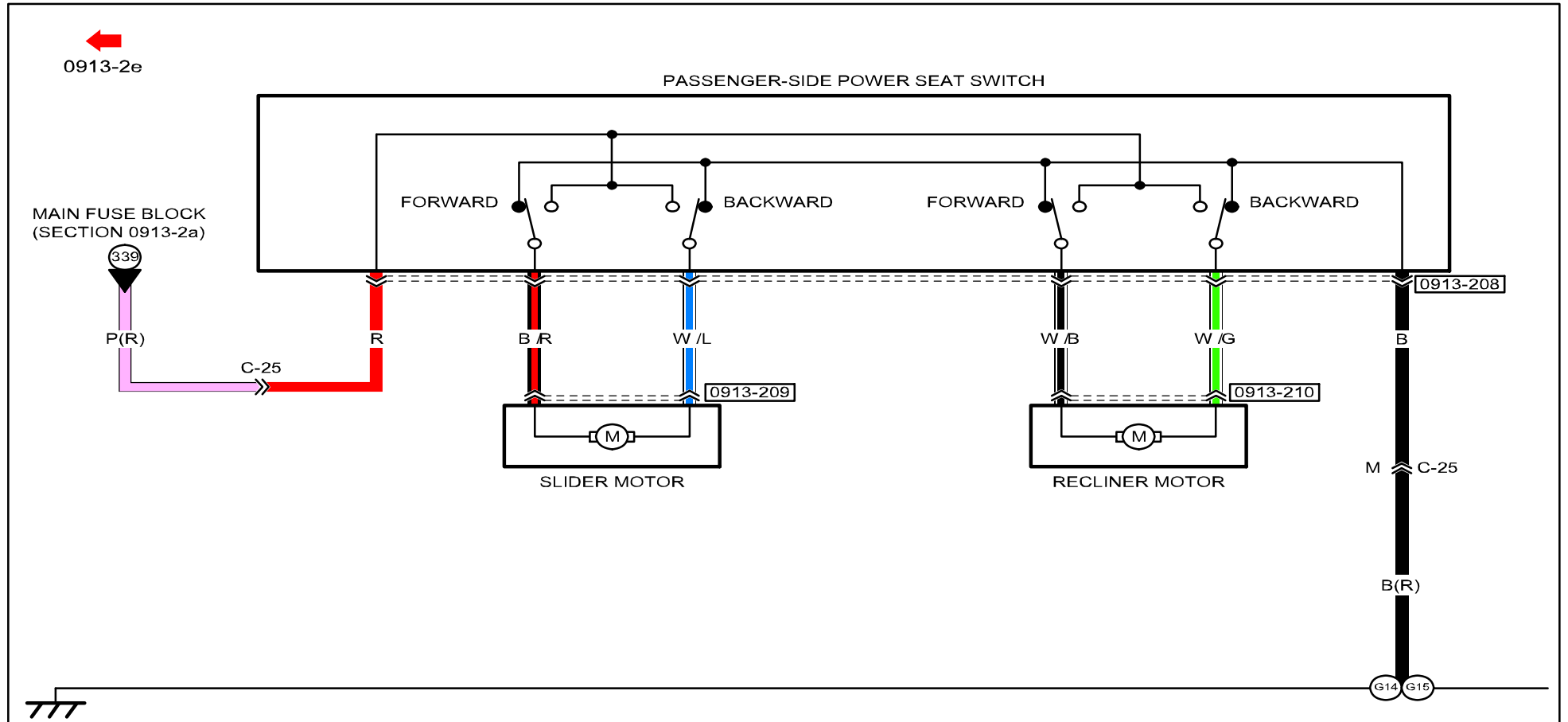

<p>0913-208 PASSENGER-SIDE POWER SEAT SWITCH</p>	<p>0913-209 SLIDER MOTOR</p>	<p>0913-210 RECLINER MOTOR</p>			

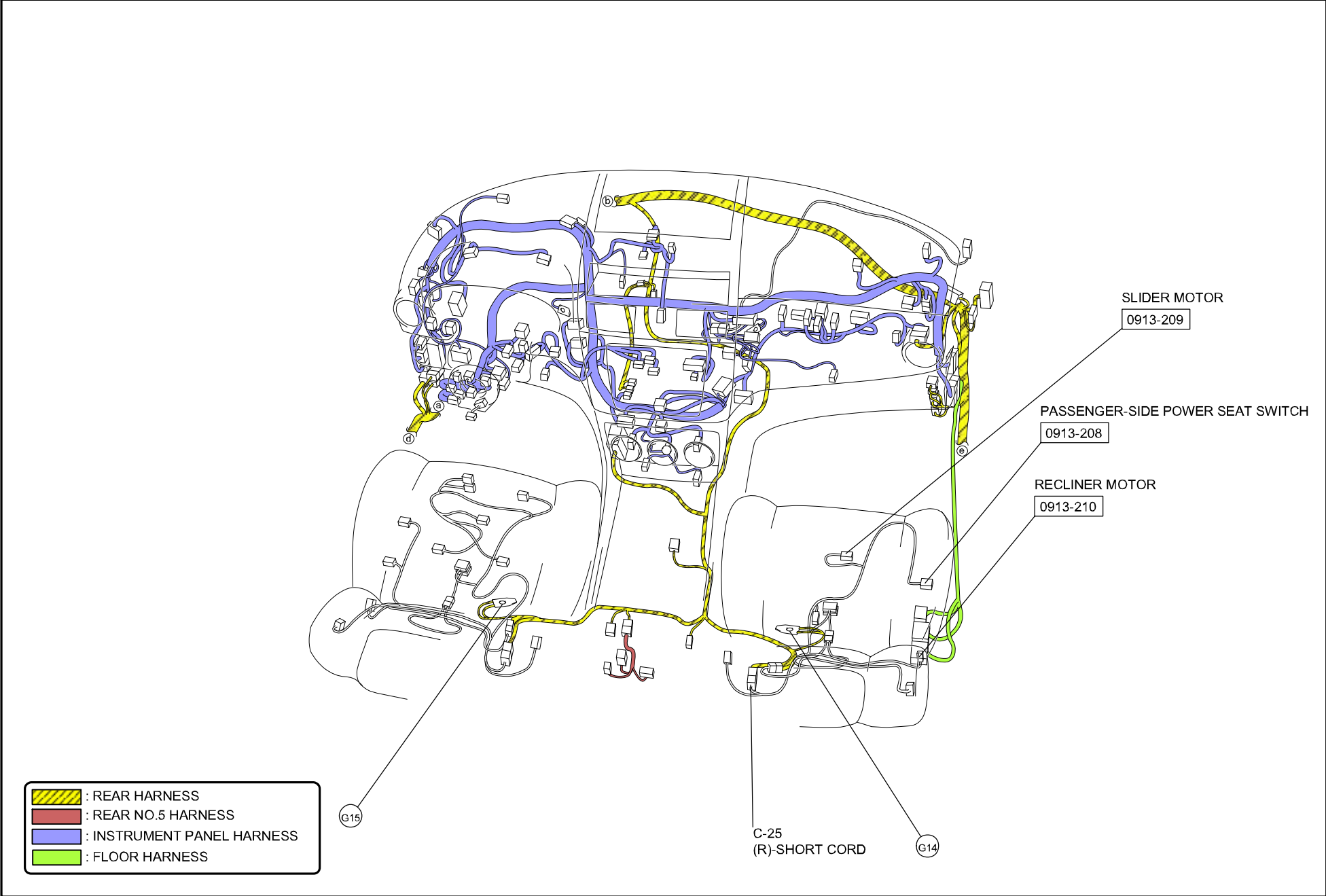

MEMORY POWER SEAT

C-25
REAR HARNESS-SHORT CORD

REAR HARNESS

SHORT CORD

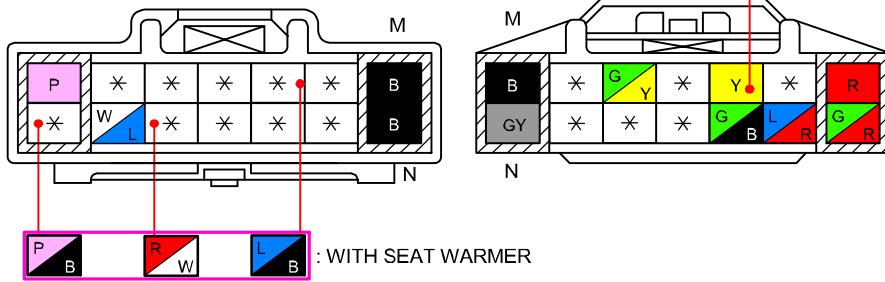

POWER DOOR LOCK SYSTEM (WITH DOUBLE LOCKING SYSTEM)

0914-1a

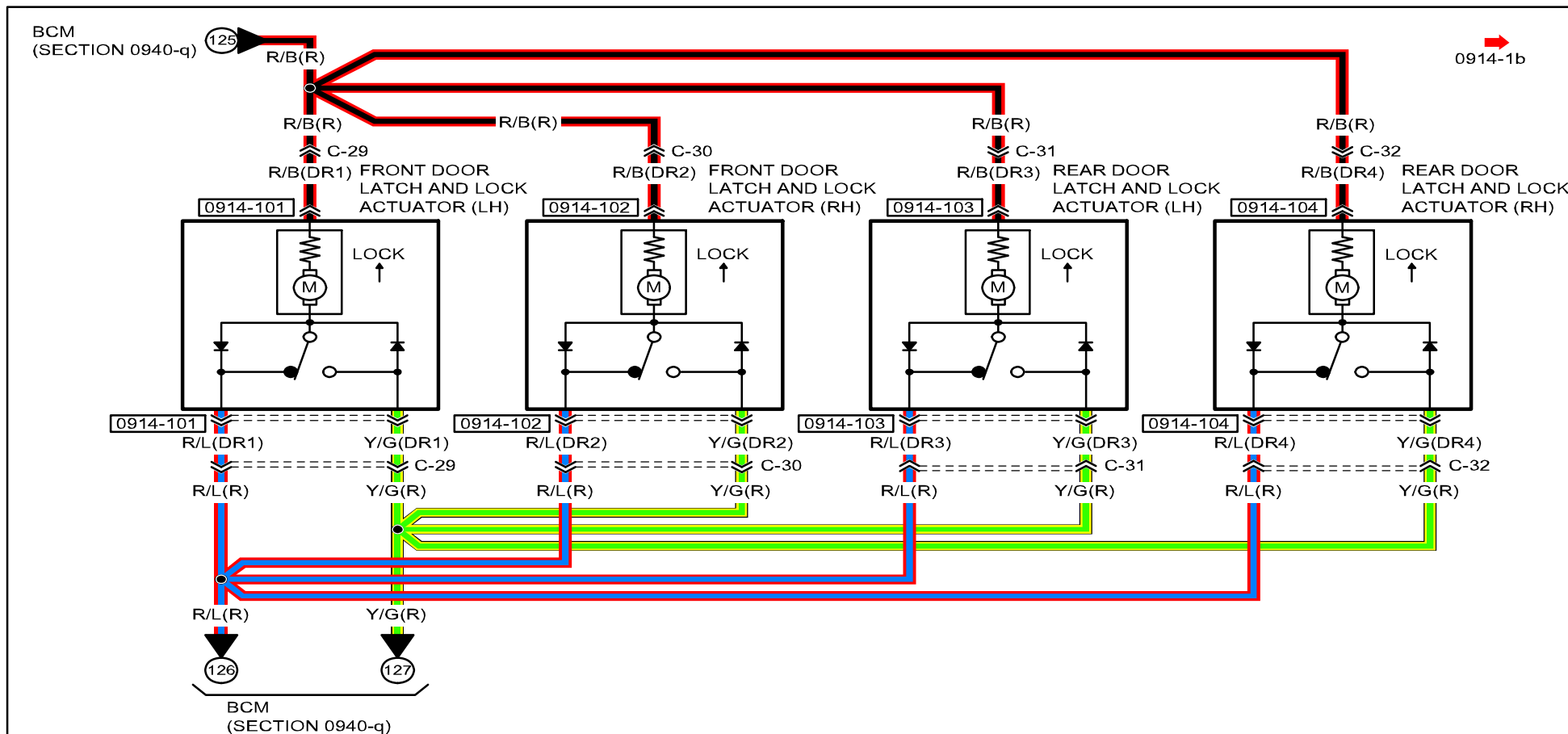

0914-101
FRONT DOOR LATCH AND LOCK ACTUATOR (LH)

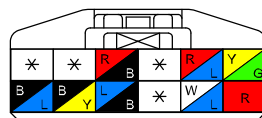

0914-102
FRONT DOOR LATCH AND LOCK ACTUATOR (RH)

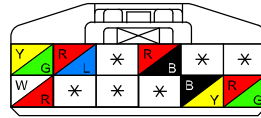

0914-103
REAR DOOR LATCH AND LOCK ACTUATOR (LH)

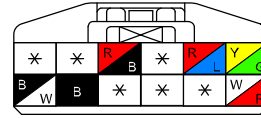

0914-104
REAR DOOR LATCH AND LOCK ACTUATOR (RH)

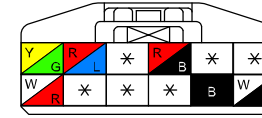

POWER DOOR LOCK SYSTEM (WITH DOUBLE LOCKING SYSTEM)

0914-1a

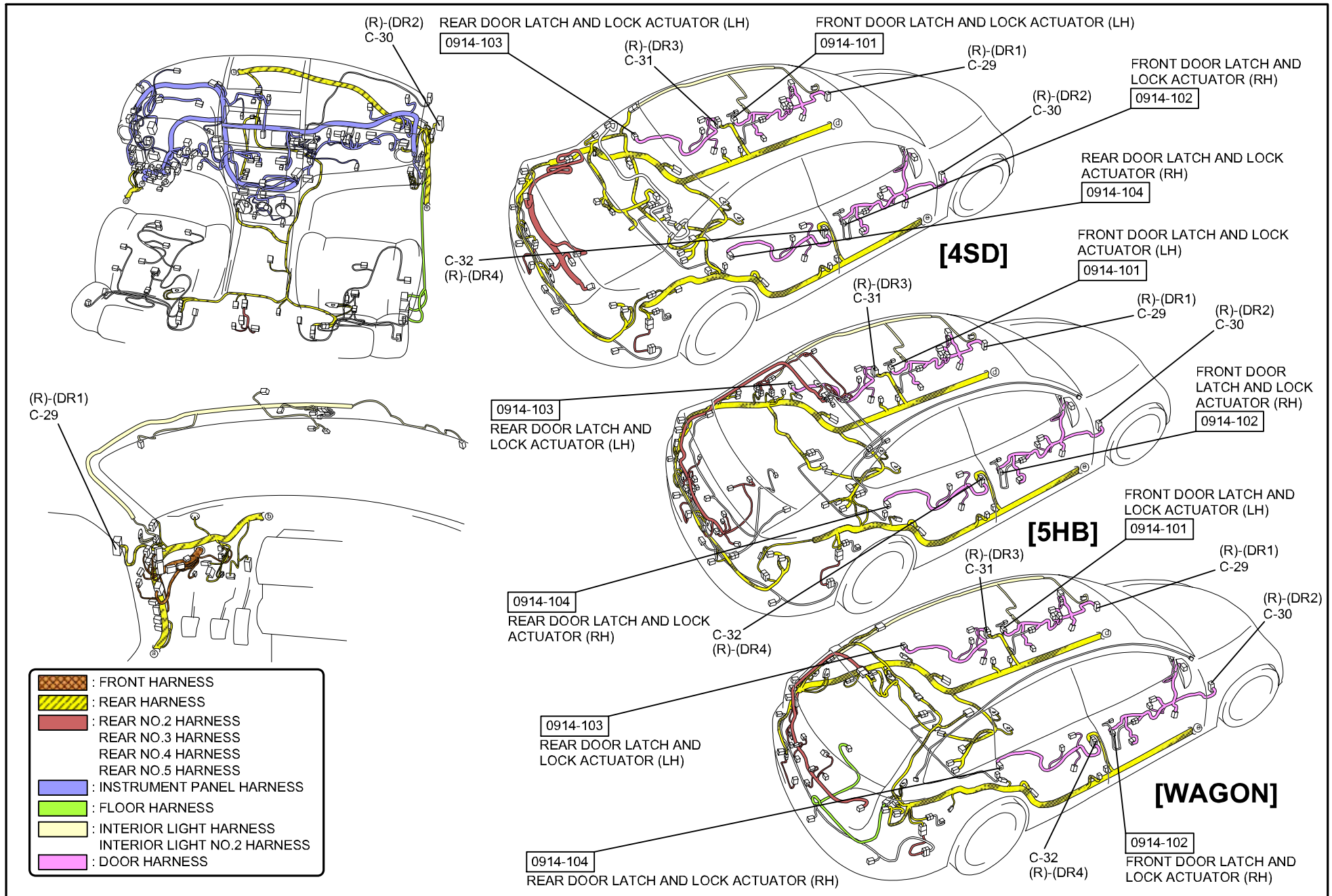

POWER DOOR LOCK SYSTEM (WITH DOUBLE LOCKING SYSTEM)

0914-1a

C-29

REAR HARNESS-DOOR NO.1 HARNESS

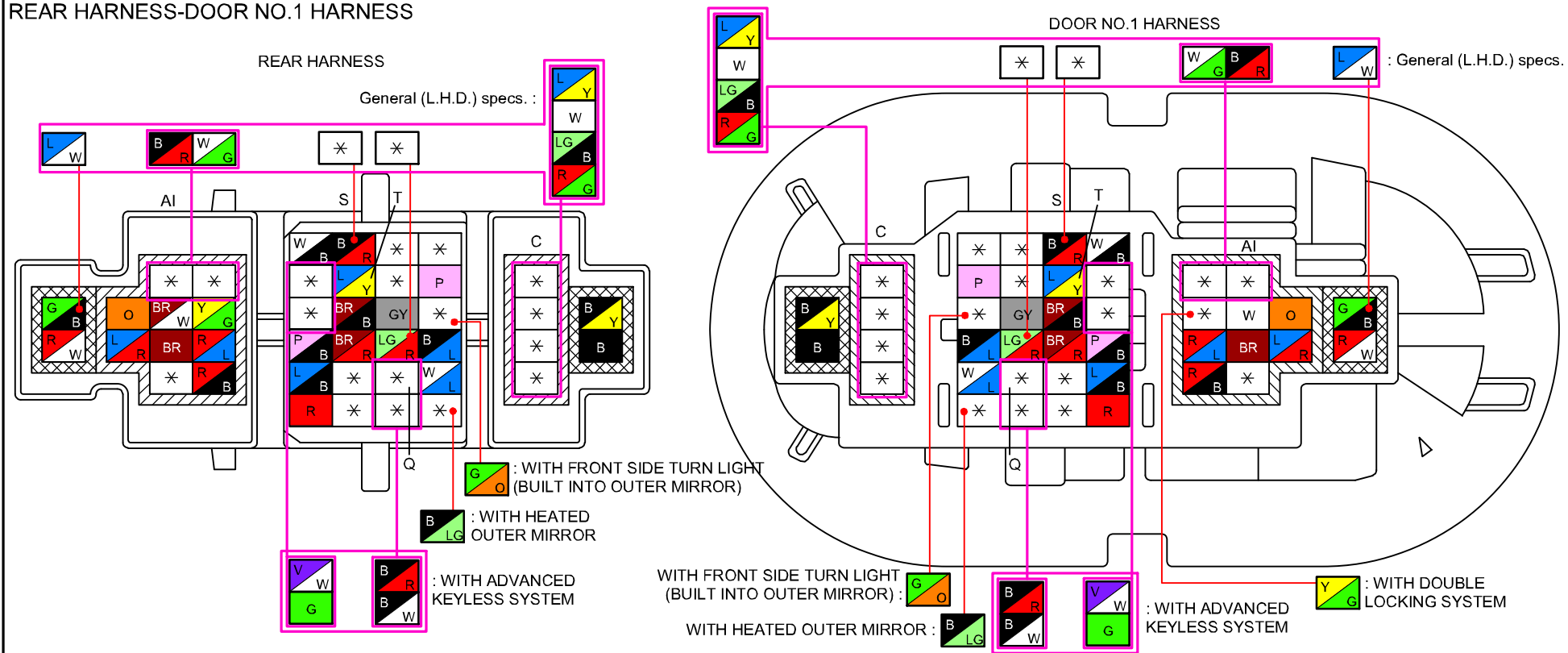

POWER DOOR LOCK SYSTEM (WITH DOUBLE LOCKING SYSTEM)

0914-1a

C-30

REAR HARNESS-DOOR NO.2 HARNESS

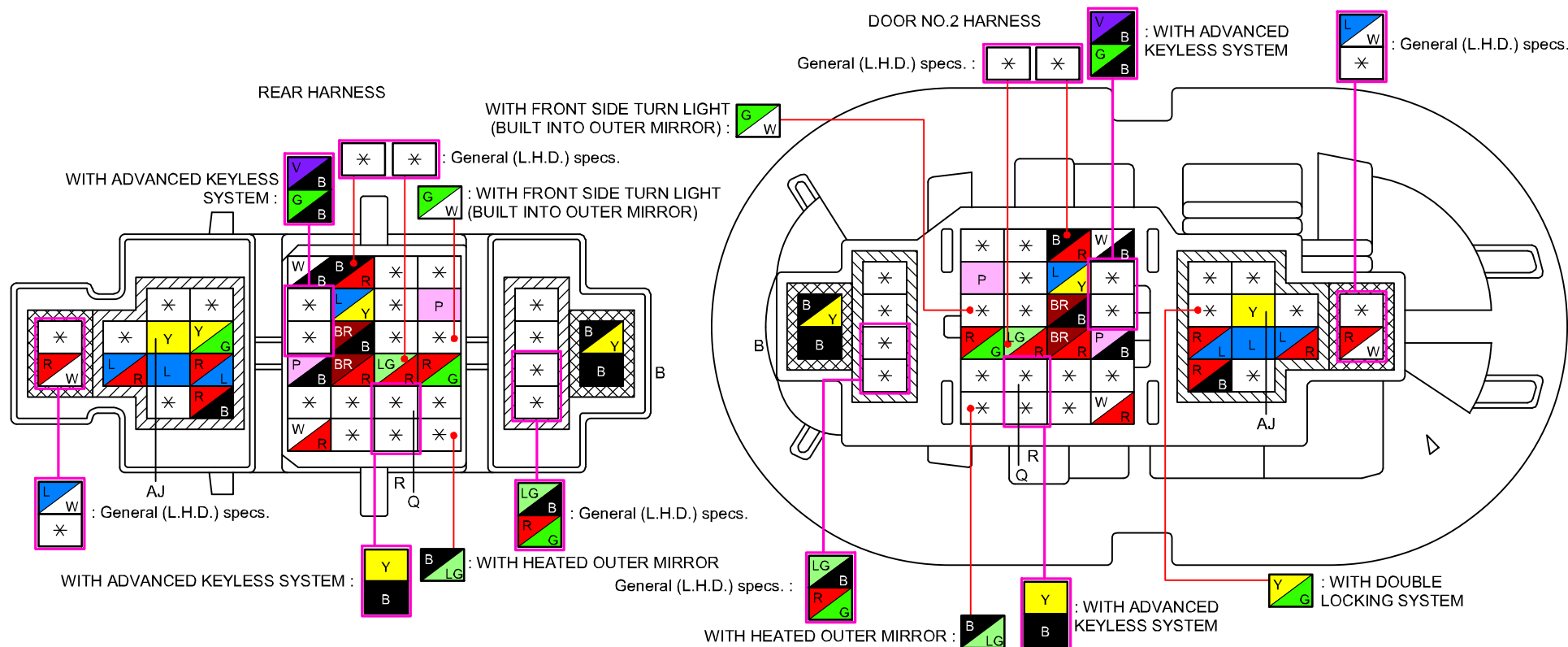

C-31

REAR HARNESS-DOOR NO.3 HARNESS

REAR HARNESS

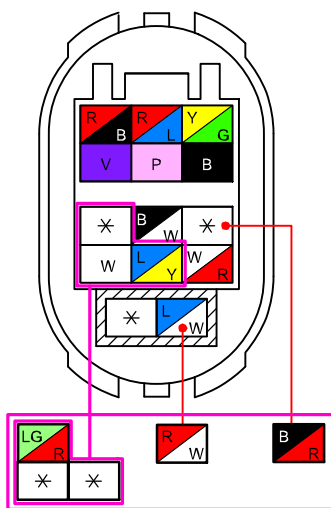

: European (L.H.D.) specs.

DOOR NO.3 HARNESS

Y G : WITH DOUBLE LOCKING SYSTEM

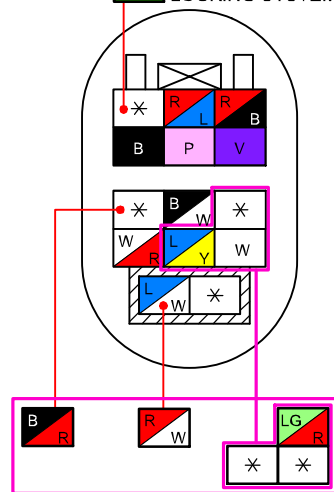

: European (L.H.D.) specs.

C-32

REAR HARNESS-DOOR NO.4 HARNESS

REAR HARNESS

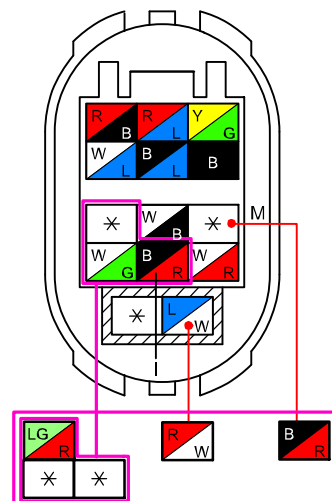

: European (L.H.D.) specs.

DOOR NO.4 HARNESS

Y G : WITH DOUBLE LOCKING SYSTEM

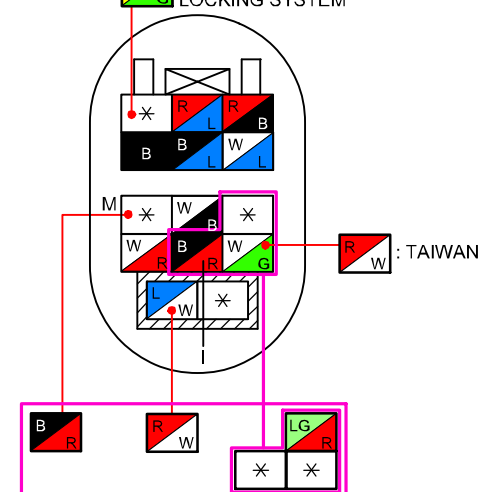

: European (L.H.D.) specs.

POWER DOOR LOCK SYSTEM (WITH DOUBLE LOCKING SYSTEM)

0914-1b

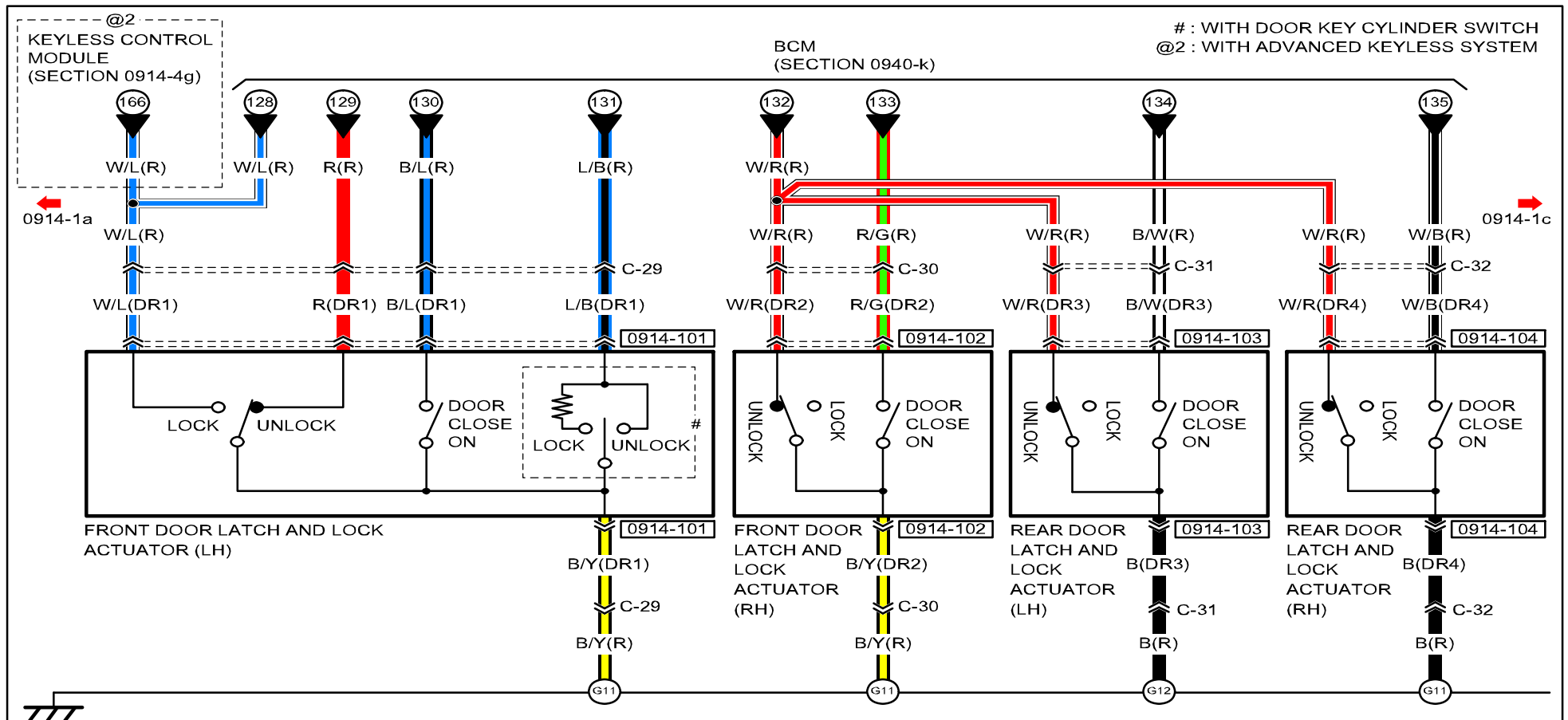

<p>0914-101 FRONT DOOR LATCH AND LOCK ACTUATOR (LH)</p>	<p>0914-102 FRONT DOOR LATCH AND LOCK ACTUATOR (RH)</p>	<p>0914-103 REAR DOOR LATCH AND LOCK ACTUATOR (LH)</p>	<p>0914-104 REAR DOOR LATCH AND LOCK ACTUATOR (RH)</p>

POWER DOOR LOCK SYSTEM (WITH DOUBLE LOCKING SYSTEM)

0914-1b

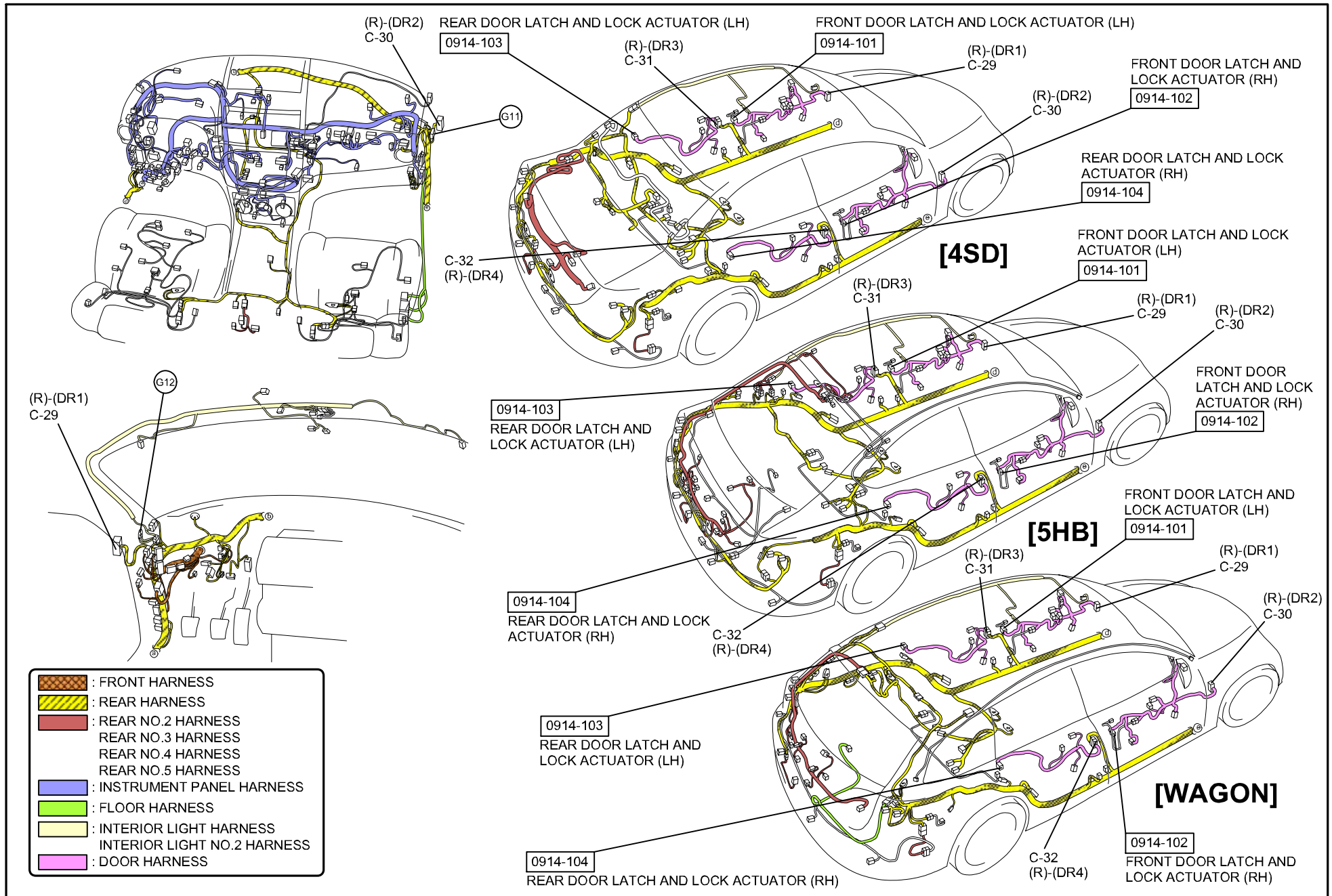

POWER DOOR LOCK SYSTEM (WITH DOUBLE LOCKING SYSTEM)

0914-1b

C-29

REAR HARNESS-DOOR NO.1 HARNESS

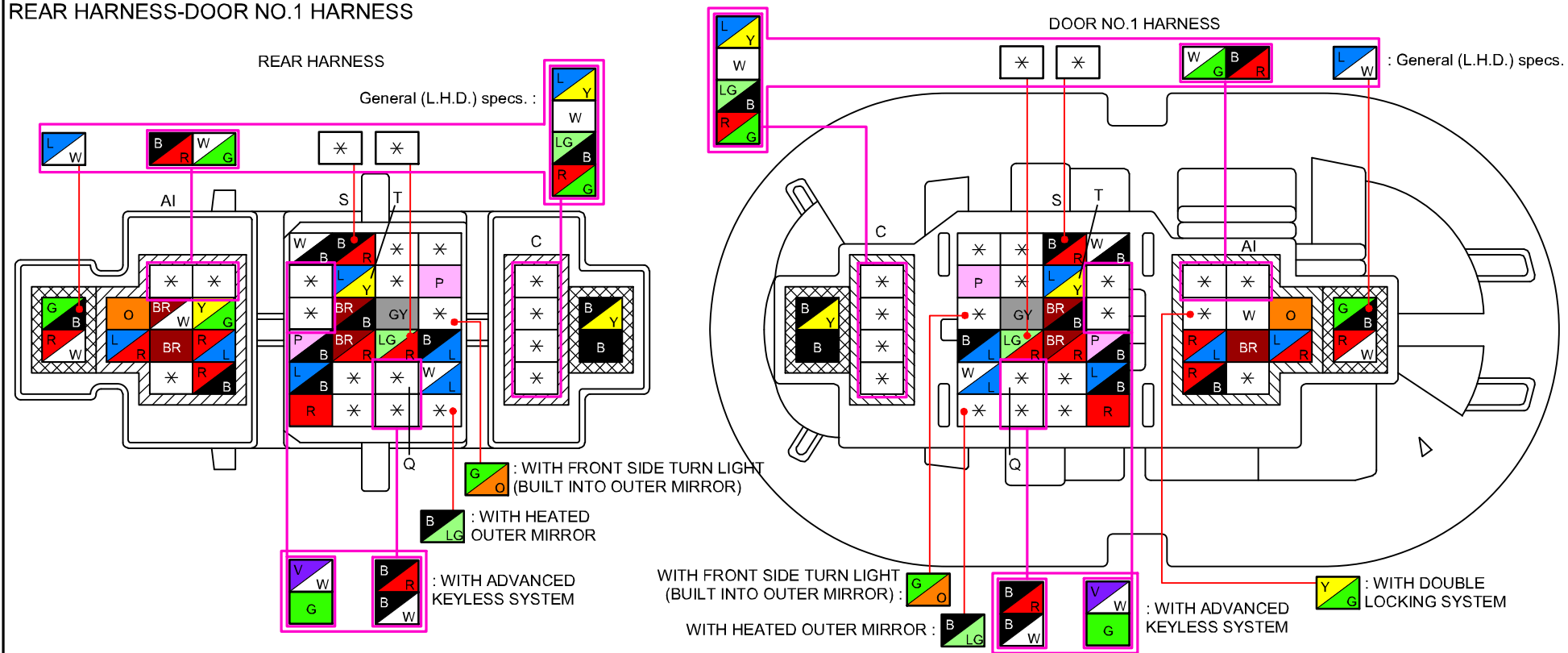

POWER DOOR LOCK SYSTEM (WITH DOUBLE LOCKING SYSTEM)

0914-1b

C-30

REAR HARNESS-DOOR NO.2 HARNESS

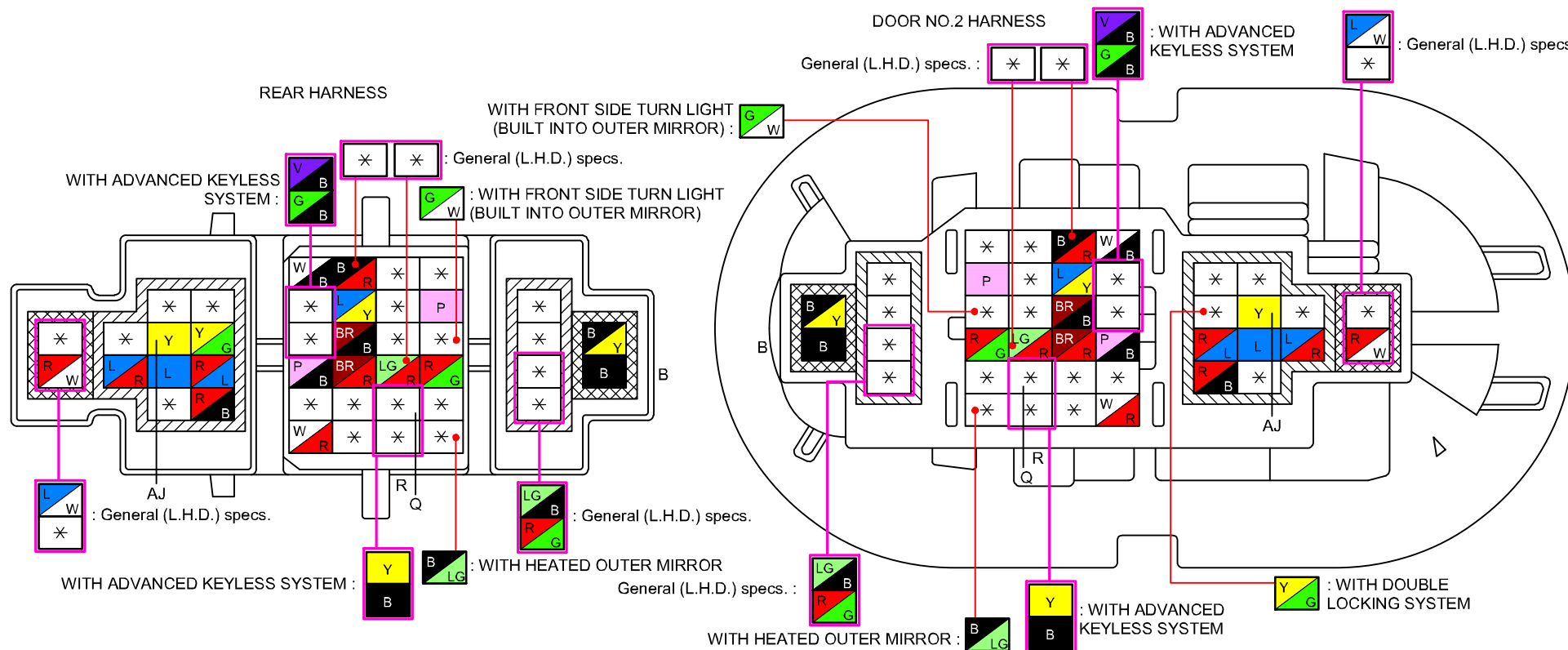

C-31

REAR HARNESS-DOOR NO.3 HARNESS

REAR HARNESS

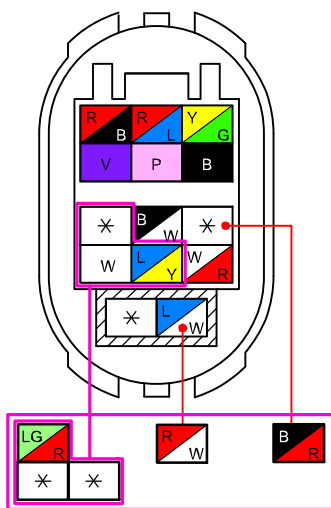

: European (L.H.D.) specs.

DOOR NO.3 HARNESS

Y G : WITH DOUBLE LOCKING SYSTEM

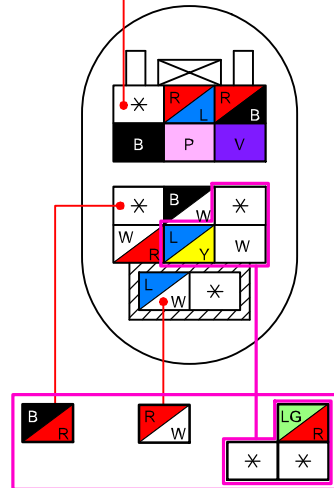

: European (L.H.D.) specs.

C-32

REAR HARNESS-DOOR NO.4 HARNESS

REAR HARNESS

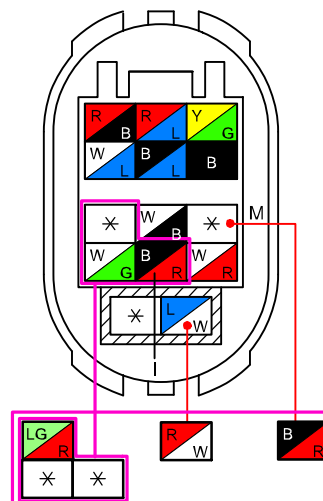

: European (L.H.D.) specs.

DOOR NO.4 HARNESS

Y G : WITH DOUBLE LOCKING SYSTEM

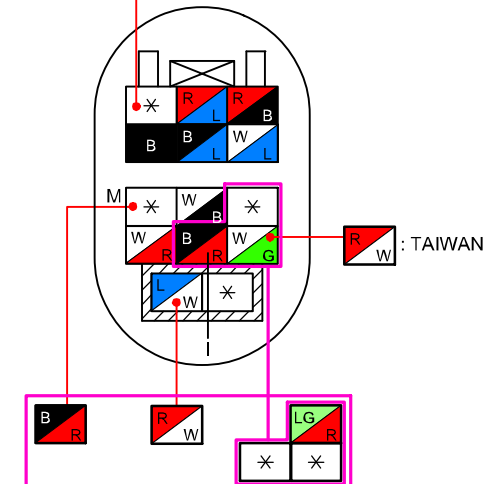



: European (L.H.D.) specs.

POWER DOOR LOCK SYSTEM (WITH DOUBLE LOCKING SYSTEM)

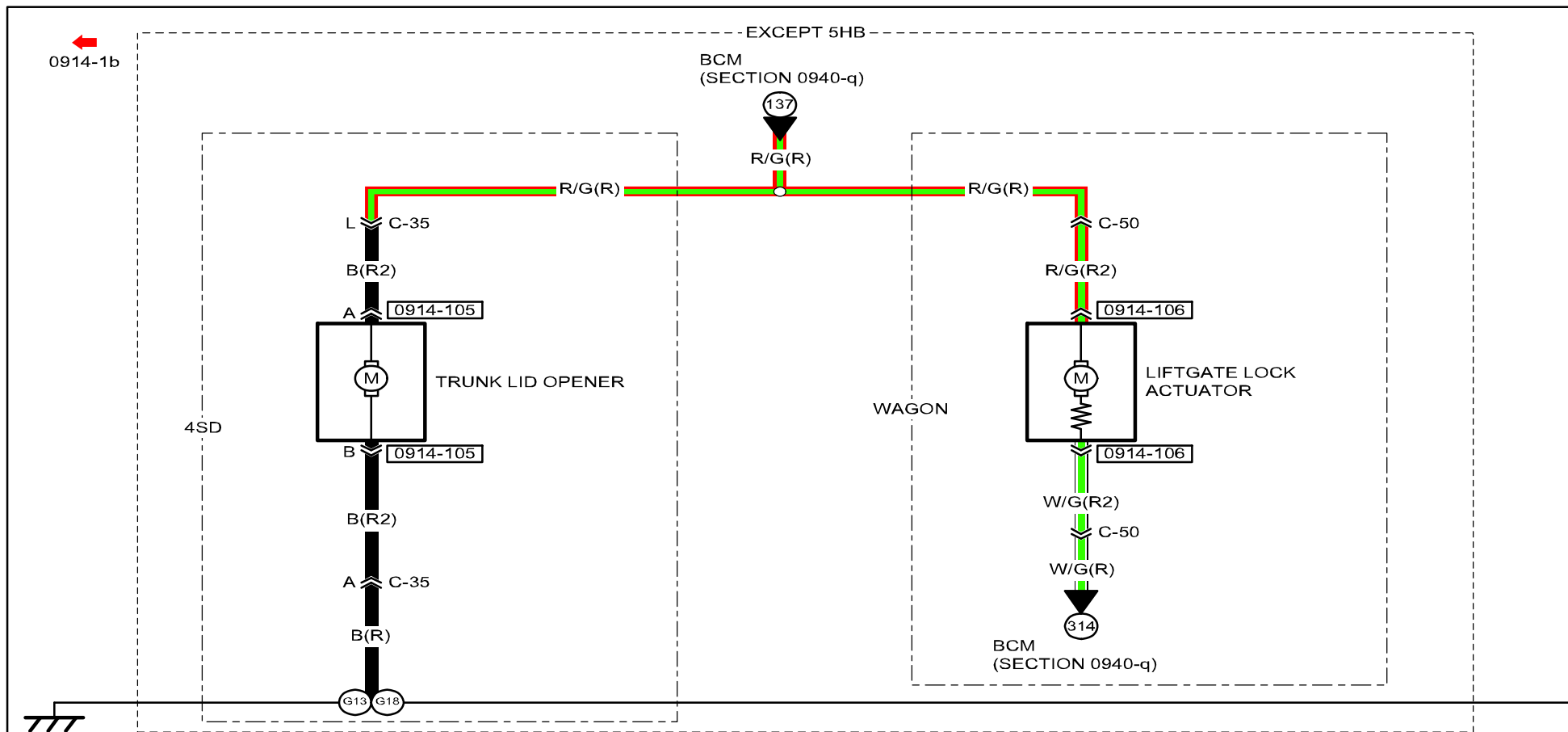
0914-1c

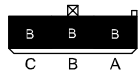

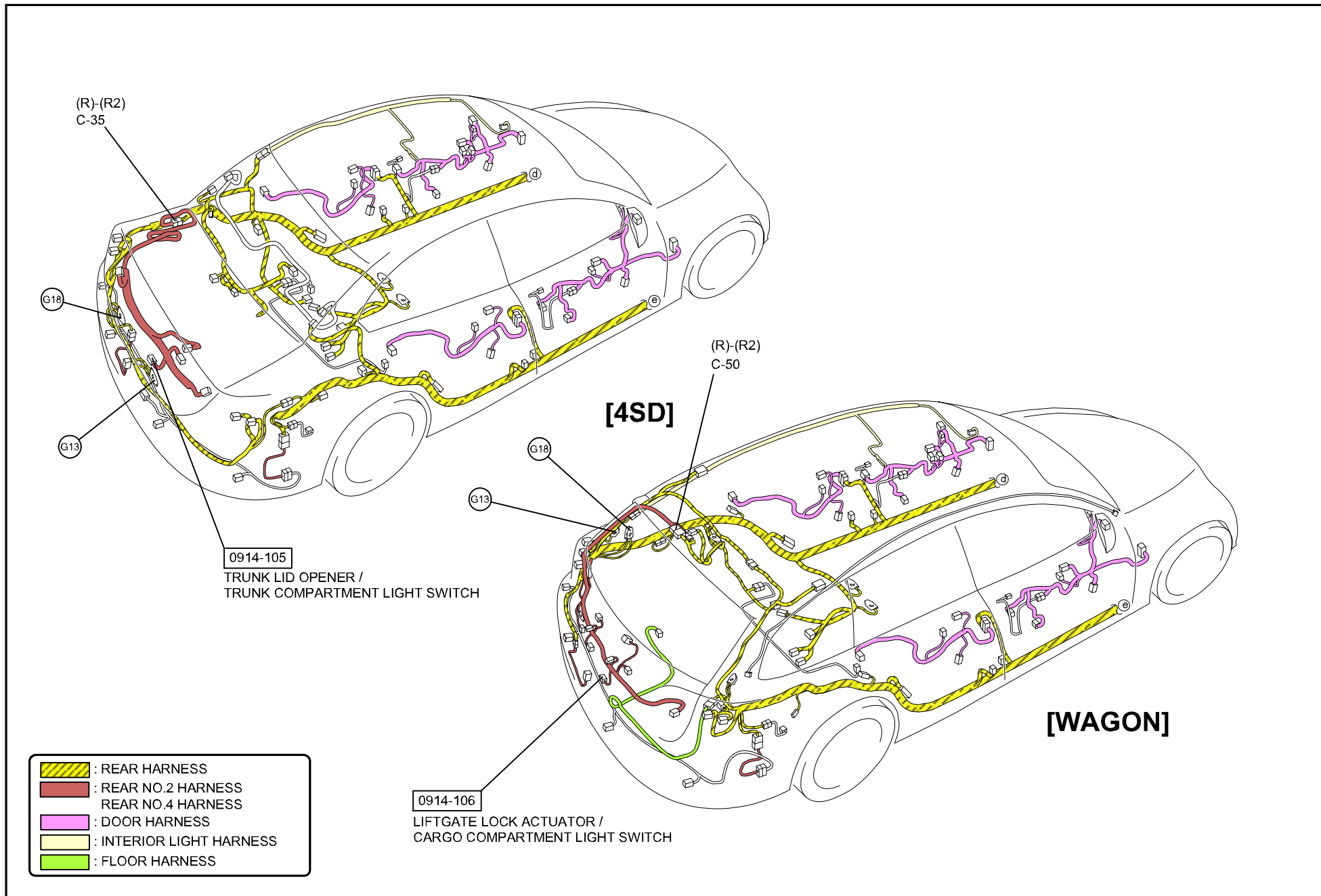

<p>0914-105 TRUNK LID OPENER / TRUNK COMPARTMENT LIGHT SWITCH</p> 	<p>0914-106 LIFTGATE LOCK ACTUATOR / CARGO COMPARTMENT LIGHT SWITCH</p> 			

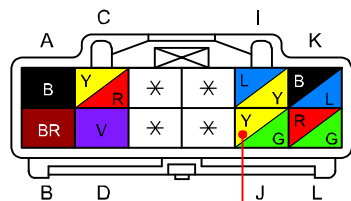

C-35
REAR HARNESS-REAR NO.2 HARNESS

REAR HARNESS



European (L.H.D.) specs. : 

(4SD)

REAR NO.2 HARNESS

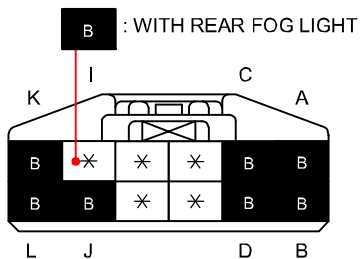

 : WITH REAR FOG LIGHT

C-50
REAR HARNESS-REAR NO.2 HARNESS

REAR HARNESS

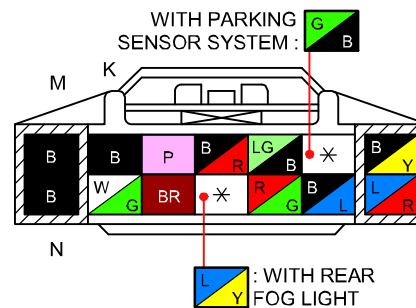

WITH PARKING SENSOR SYSTEM : 

 : WITH REAR FOG LIGHT

REAR NO.2 HARNESS

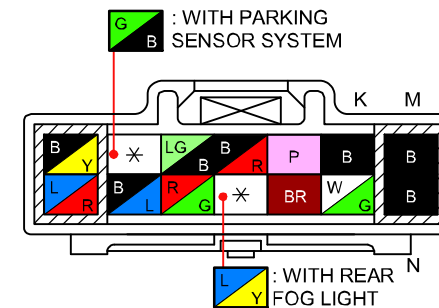

 : WITH PARKING SENSOR SYSTEM

 : WITH REAR FOG LIGHT

(WAGON)

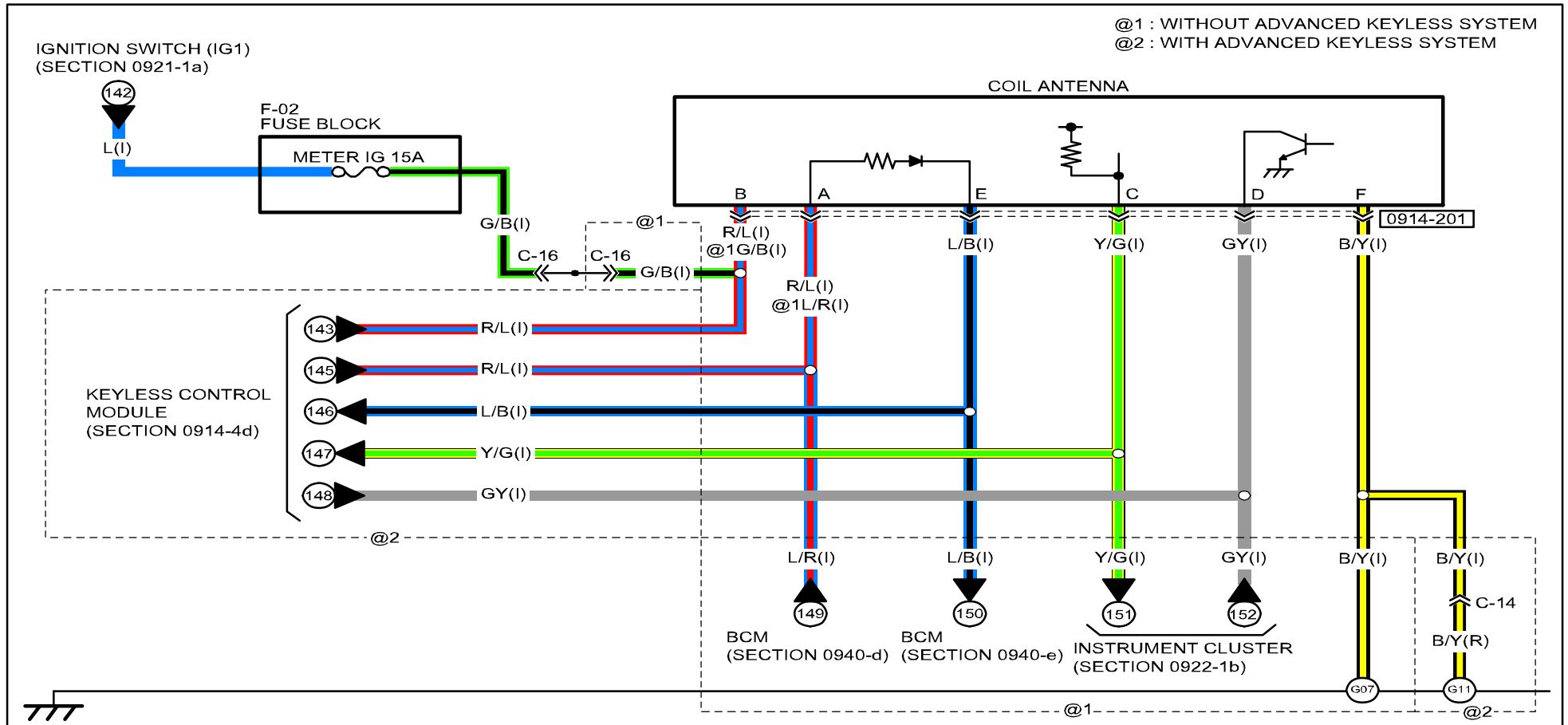

<p>0914-201 COIL ANTENNA</p> <p>Legend: : WITHOUT ADVANCED KEYLESS SYSTEM : WITH ADVANCED KEYLESS SYSTEM</p>					
--	--	--	--	--	--

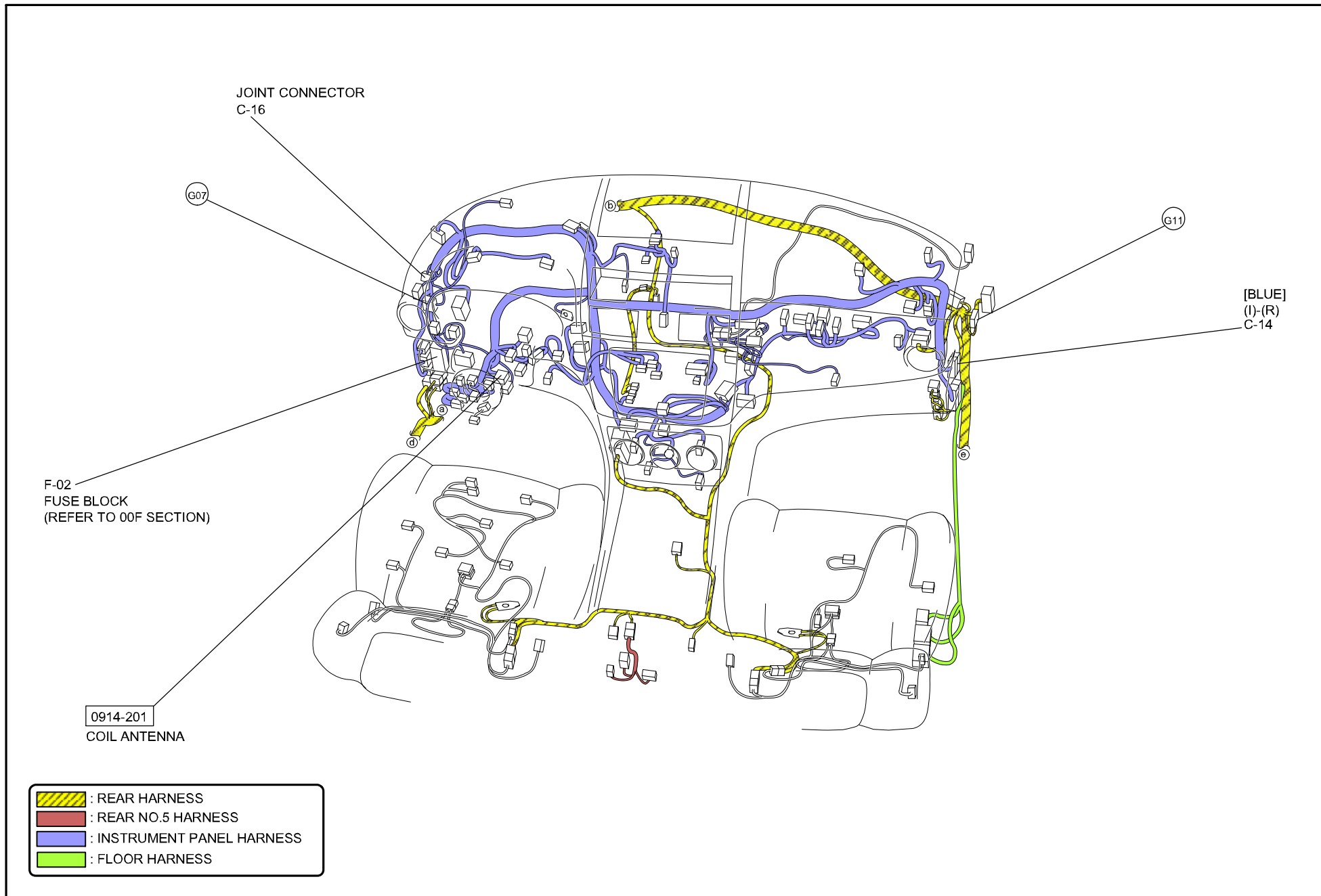

JOINT CONNECTOR
C-16





G07

G11

[BLUE]
(L)-(R)
C-14

F-02
FUSE BLOCK
(REFER TO 00F SECTION)

0914-201
COIL ANTENNA

-  : REAR HARNESS
-  : REAR NO.5 HARNESS
-  : INSTRUMENT PANEL HARNESS
-  : FLOOR HARNESS

C-14
INSTRUMENT PANEL HARNESS-REAR HARNESS

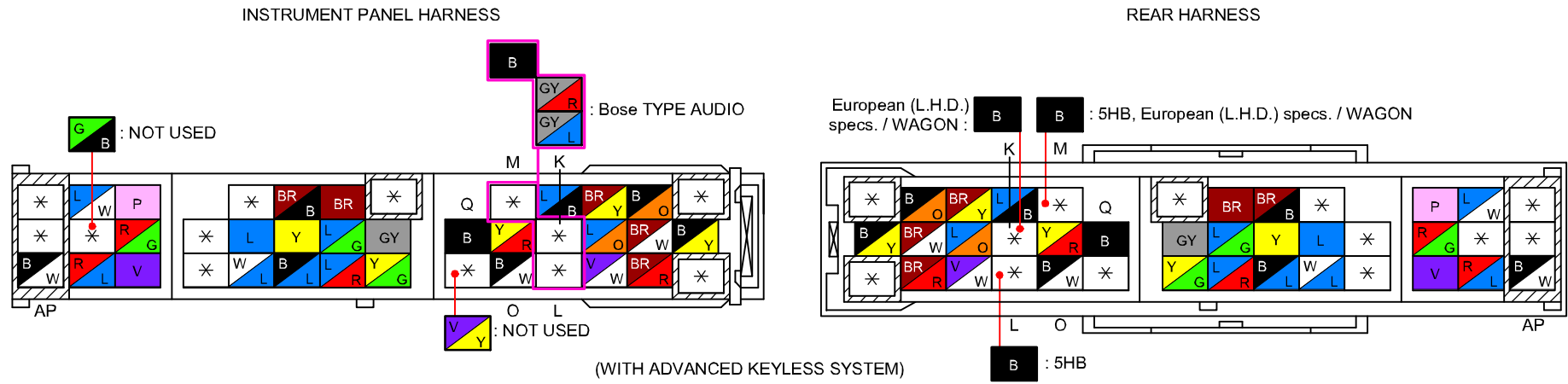

C-16
JOINT CONNECTOR

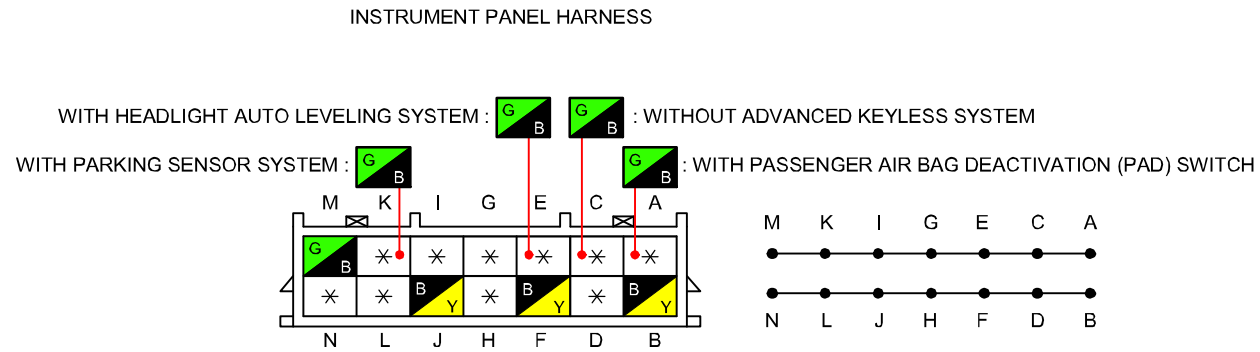

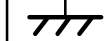
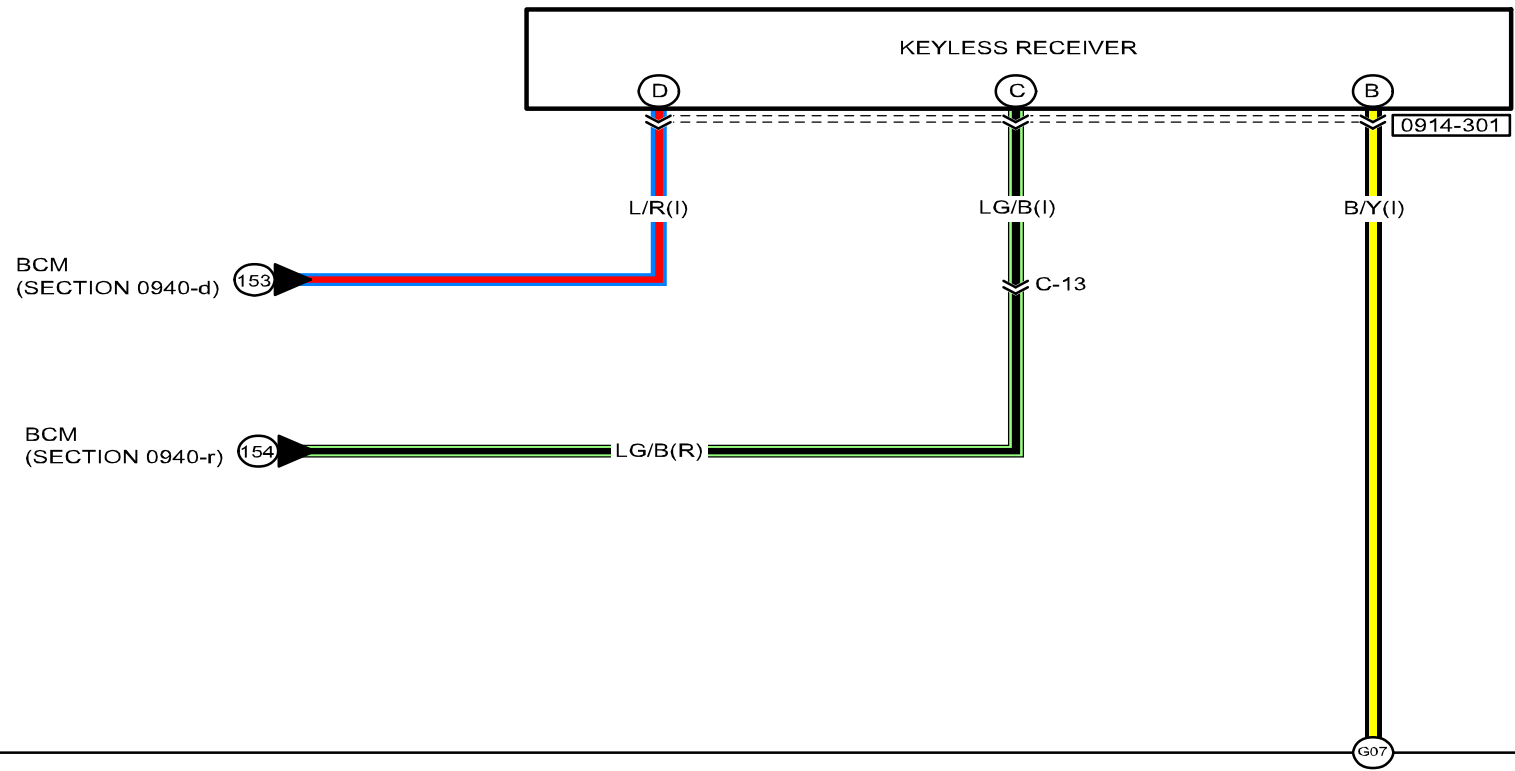

0914-301
KEYLESS RECEIVER

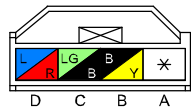

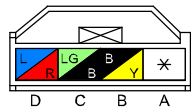

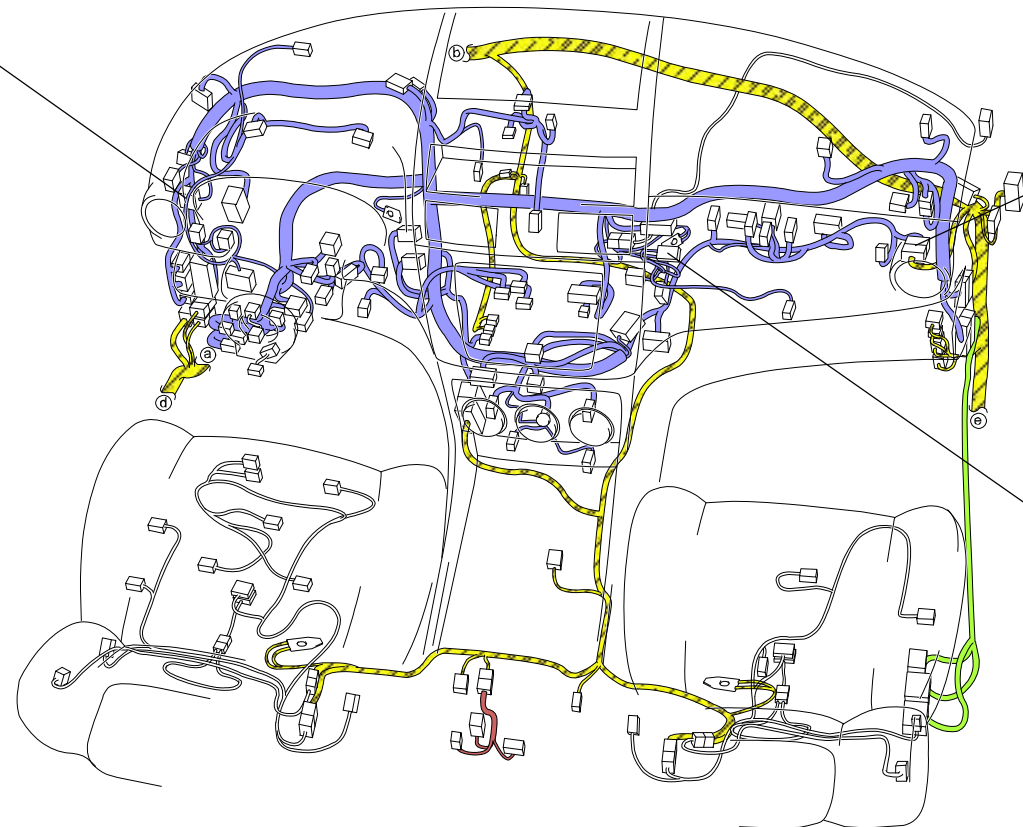

<p>0914-301 KEYLESS RECEIVER</p> 						

G07

(L)-(R)
C-13



0914-301
KEYLESS RECEIVER

-  : REAR HARNESS
-  : REAR NO.5 HARNESS
-  : INSTRUMENT PANEL HARNESS
-  : FLOOR HARNESS

C-13

INSTRUMENT PANEL HARNESS-REAR HARNESS

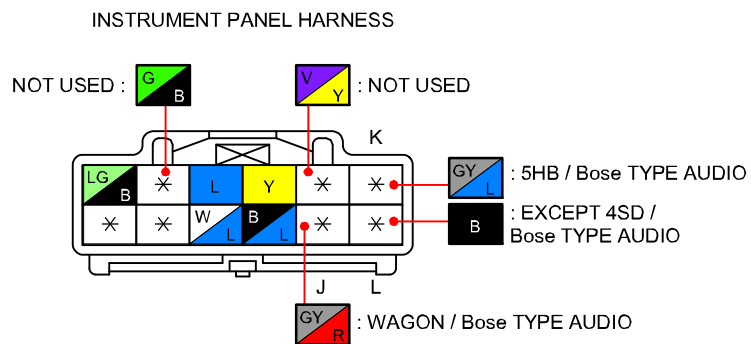

(WITHOUT ADVANCED KEYLESS SYSTEM)

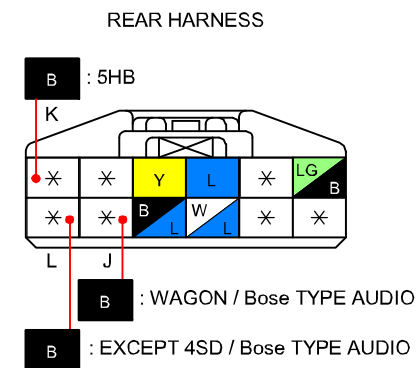

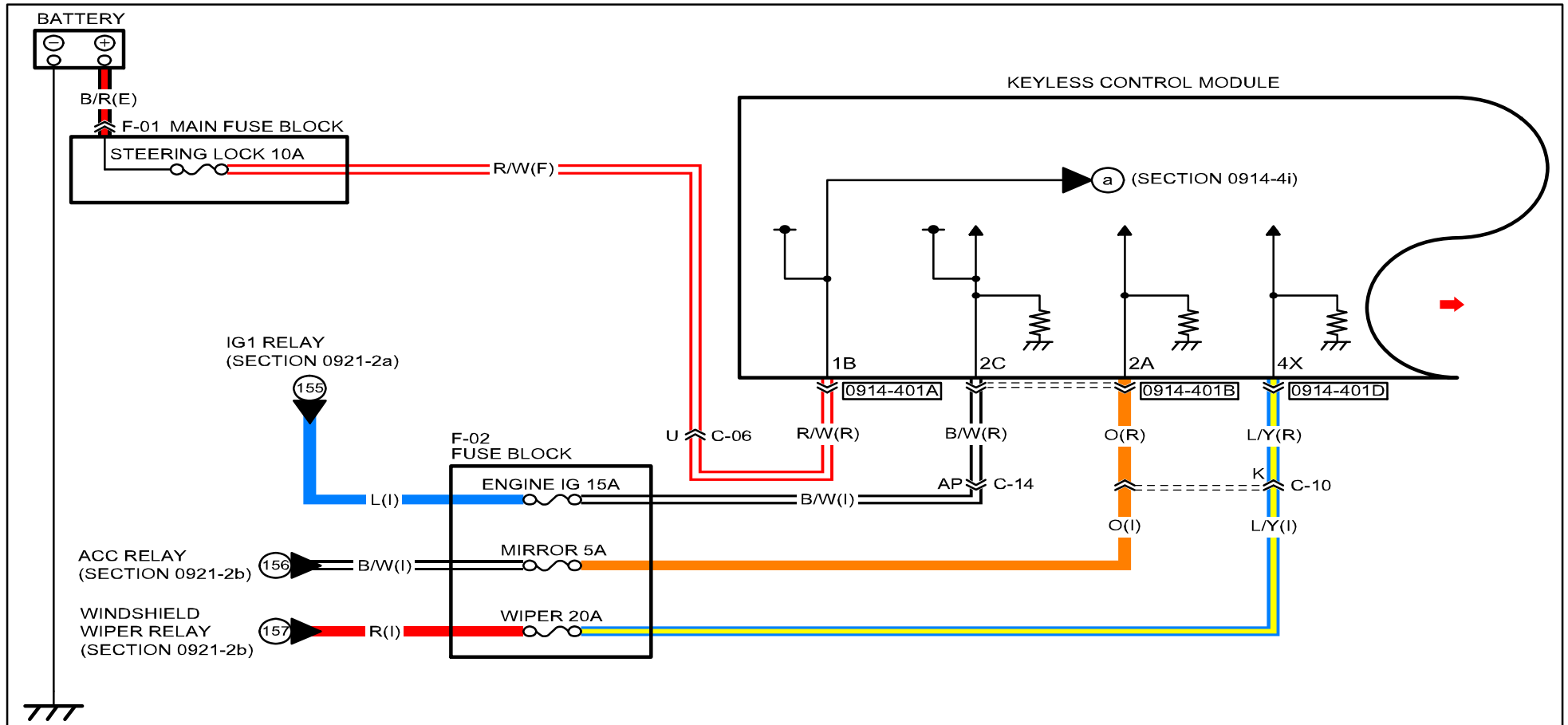

<p>0914-401A KEYLESS CONTROL MODULE</p>	<p>0914-401B KEYLESS CONTROL MODULE</p>	<p>0914-401D KEYLESS CONTROL MODULE</p>	

ADVANCED KEYLESS ENTRY AND PUSH BUTTON START SYSTEM

0914-4a

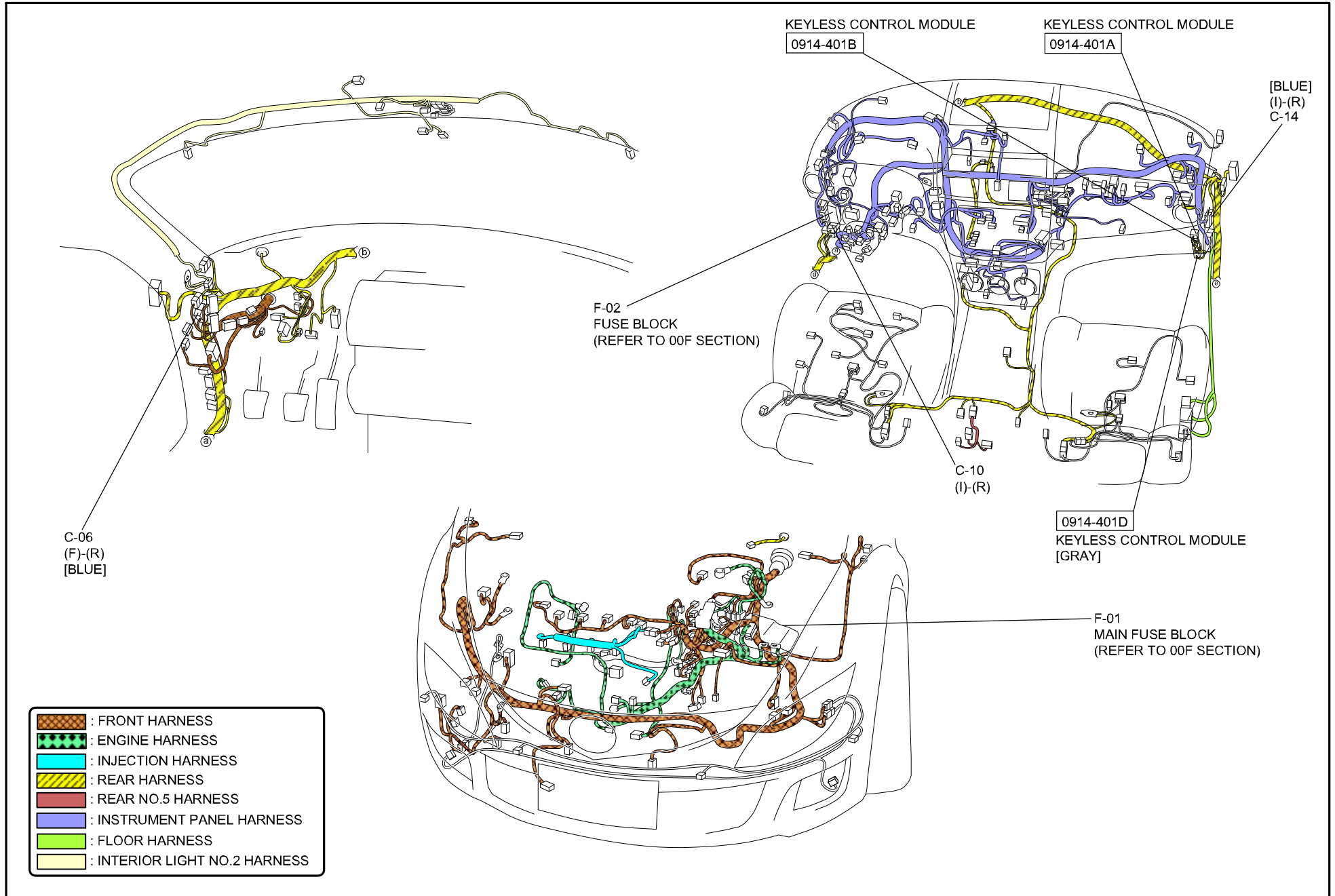

C-06

FRONT HARNESS-REAR HARNESS

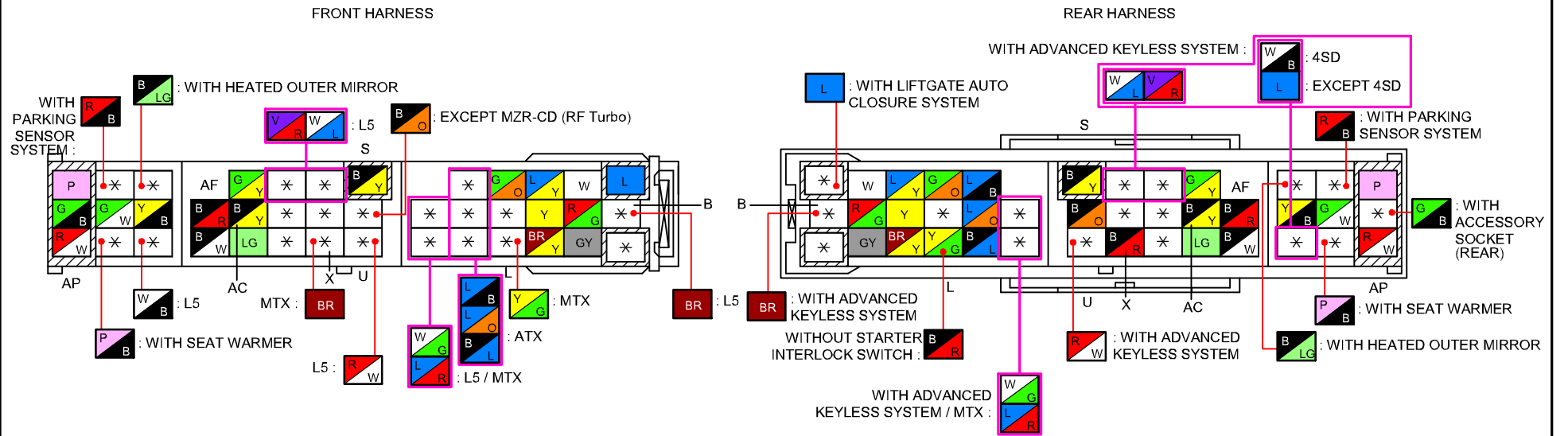

C-10

INSTRUMENT PANEL HARNESS-REAR HARNESS

INSTRUMENT PANEL HARNESS

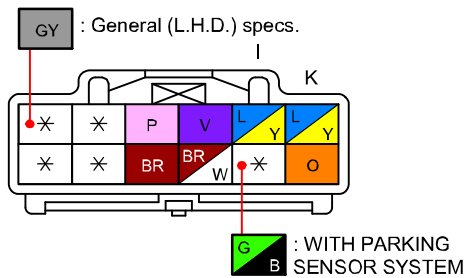

REAR HARNESS

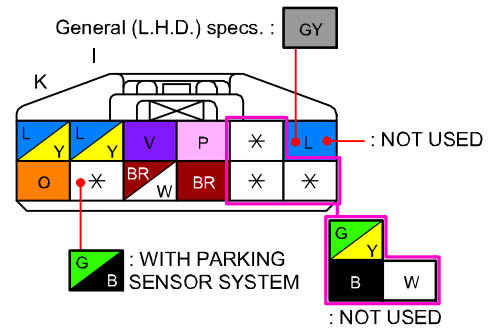

C-14

INSTRUMENT PANEL HARNESS-REAR HARNESS

INSTRUMENT PANEL HARNESS

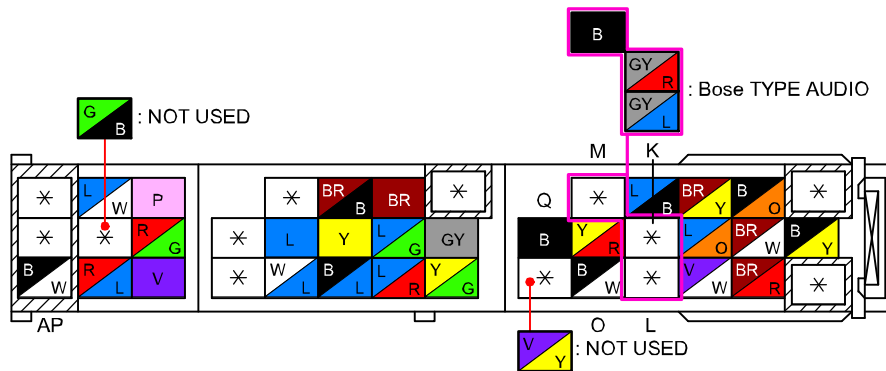

(WITH ADVANCED KEYLESS SYSTEM)

REAR HARNESS

European (L.H.D.) specs. / WAGON : B B : 5HB, European (L.H.D.) specs. / WAGON

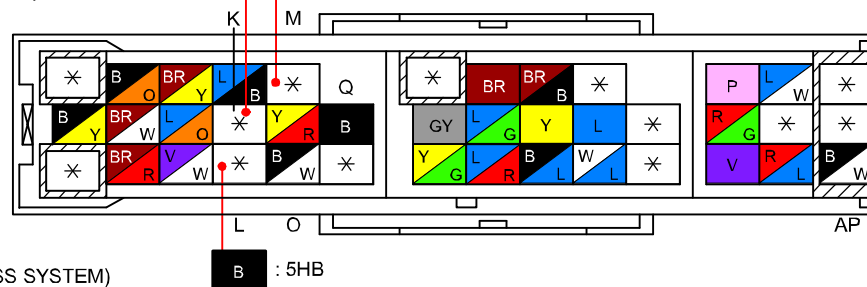

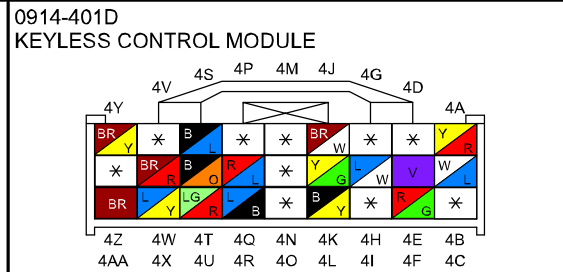
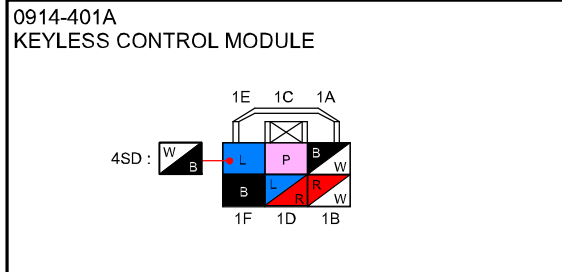
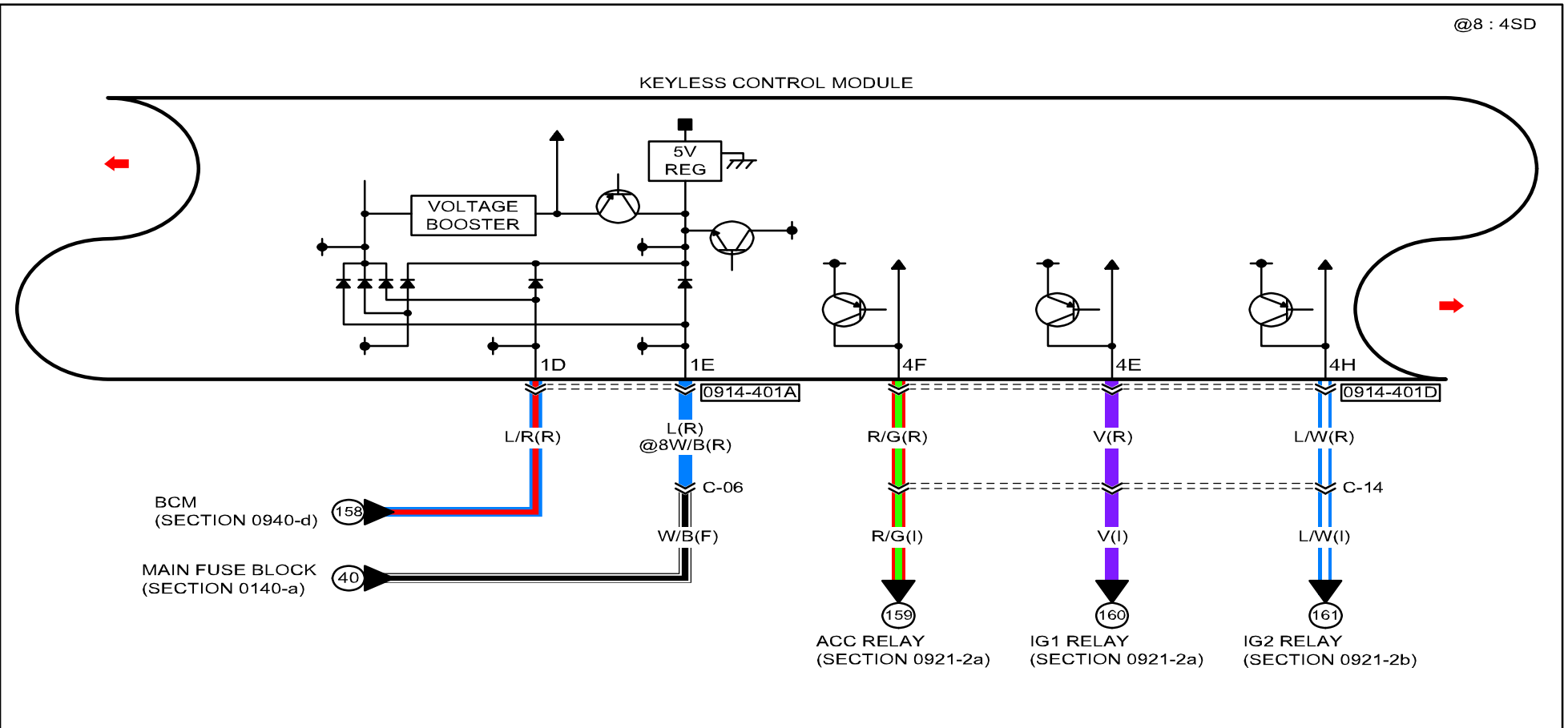

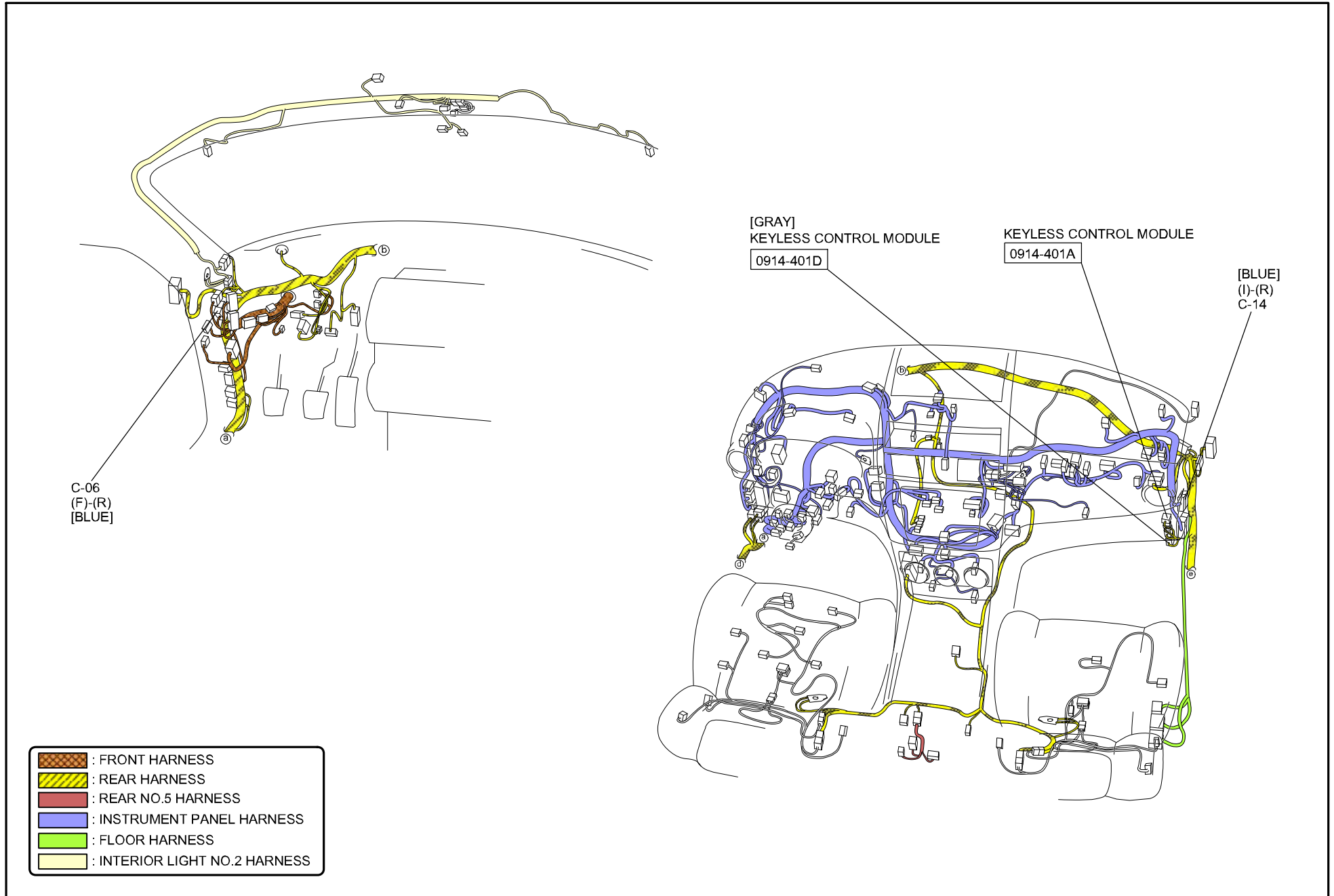

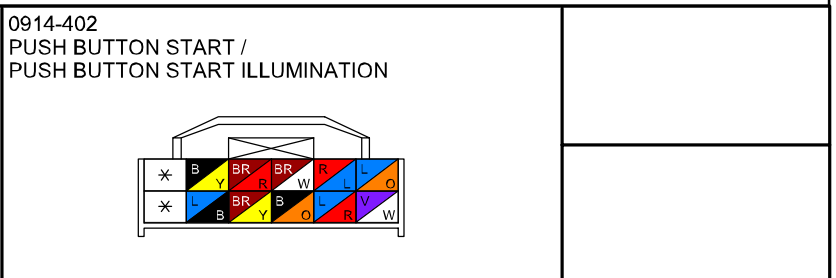
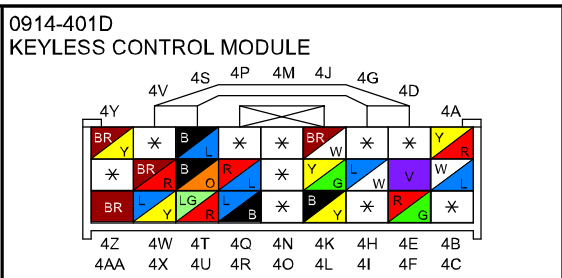
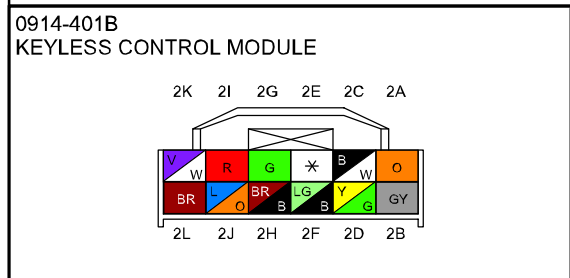
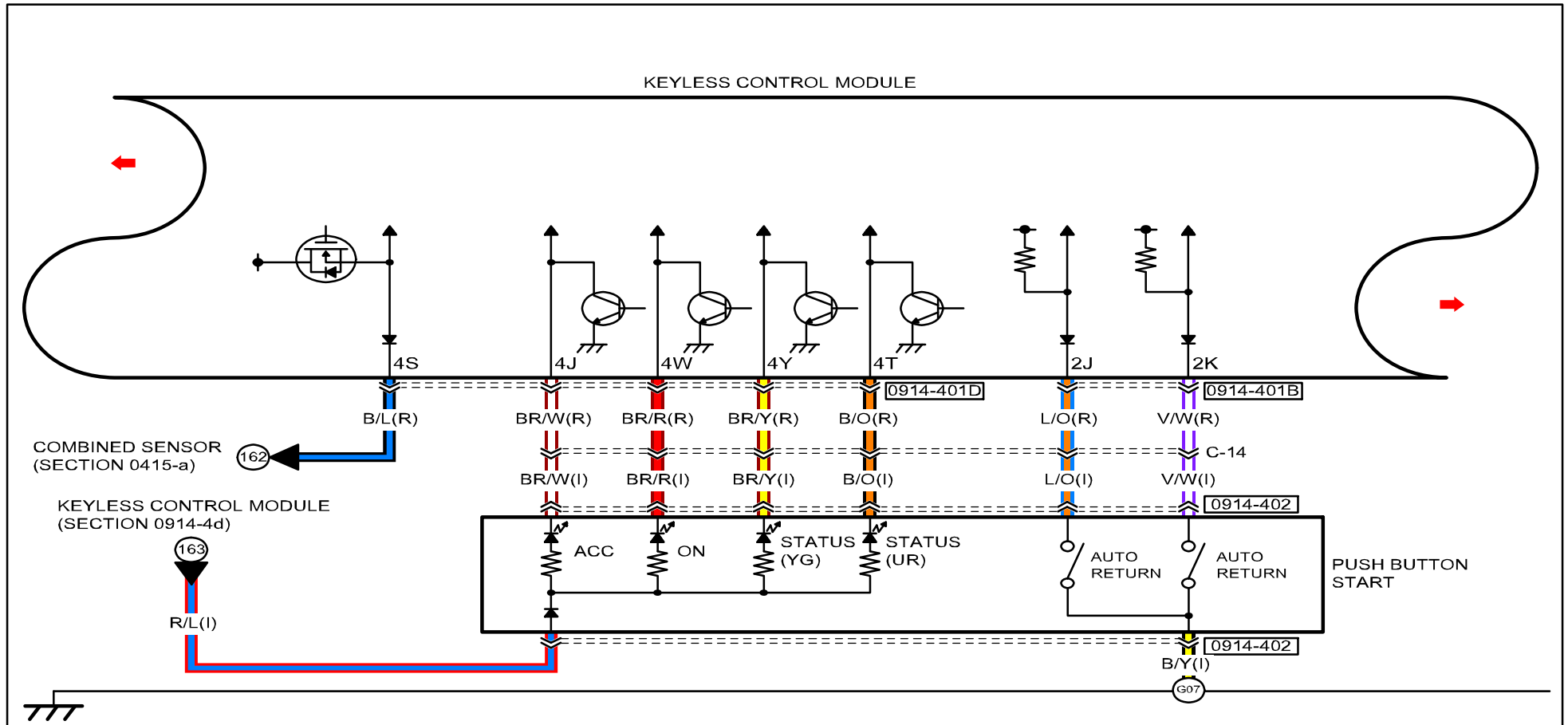

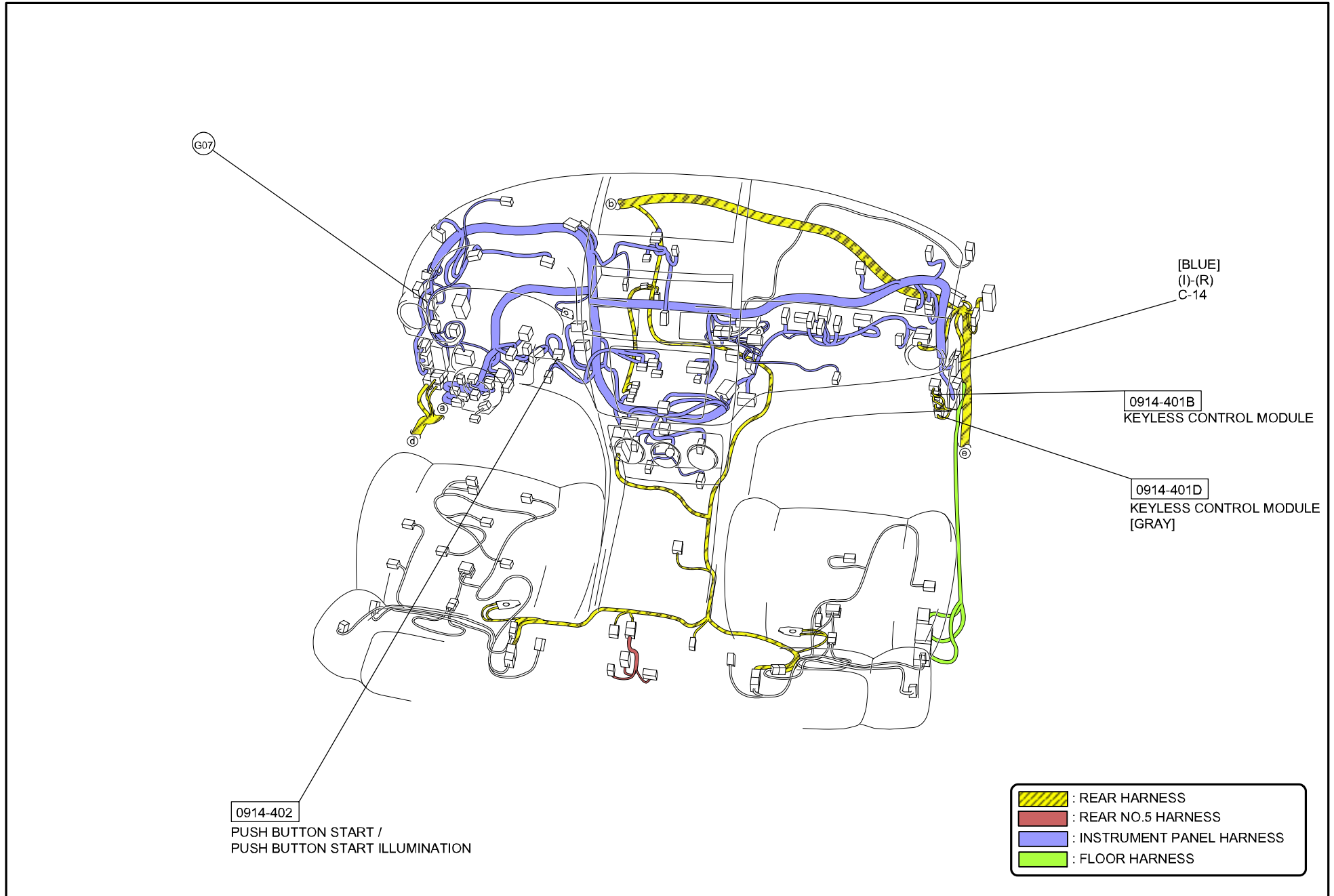

C-14

INSTRUMENT PANEL HARNESS-REAR HARNESS

INSTRUMENT PANEL HARNESS

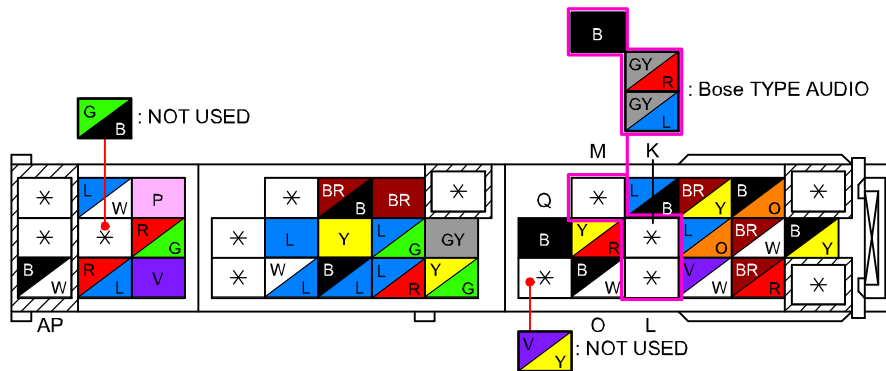

(WITH ADVANCED KEYLESS SYSTEM)

REAR HARNESS

European (L.H.D.) specs. / WAGON : B B : 5HB, European (L.H.D.) specs. / WAGON

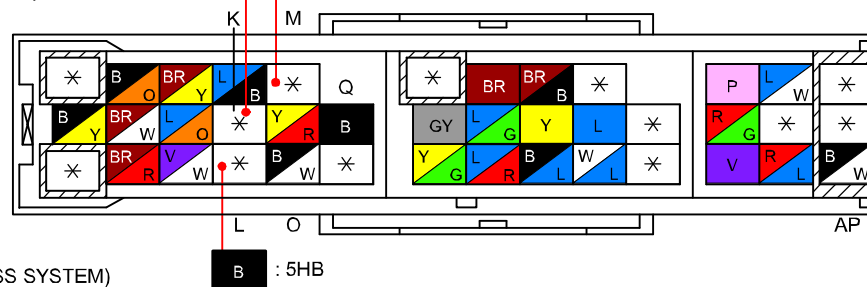

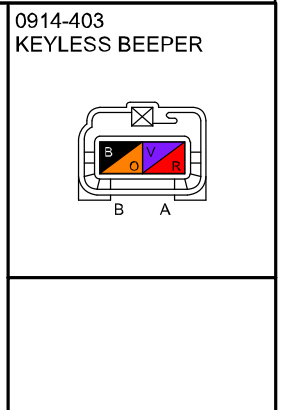
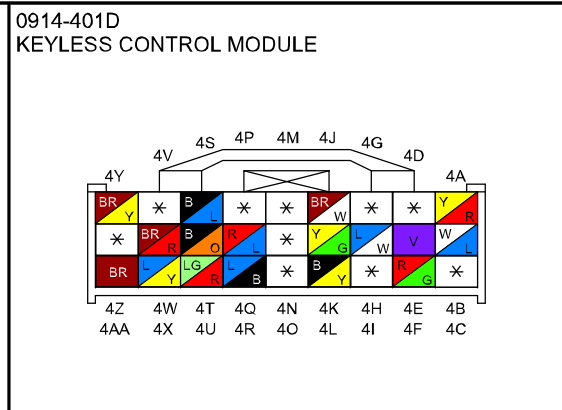
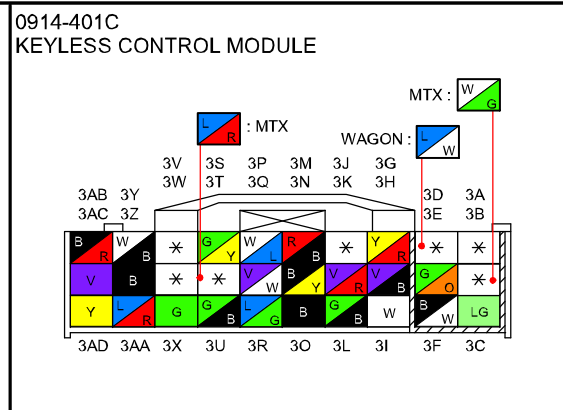
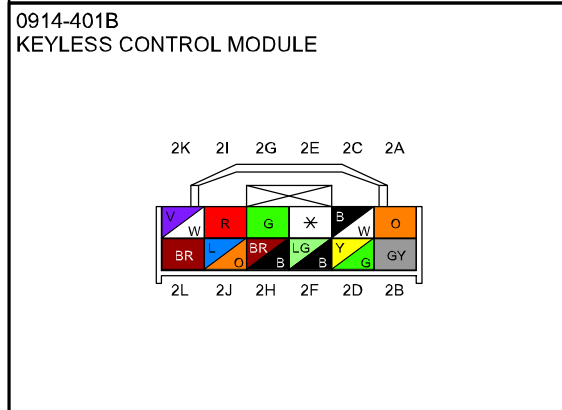
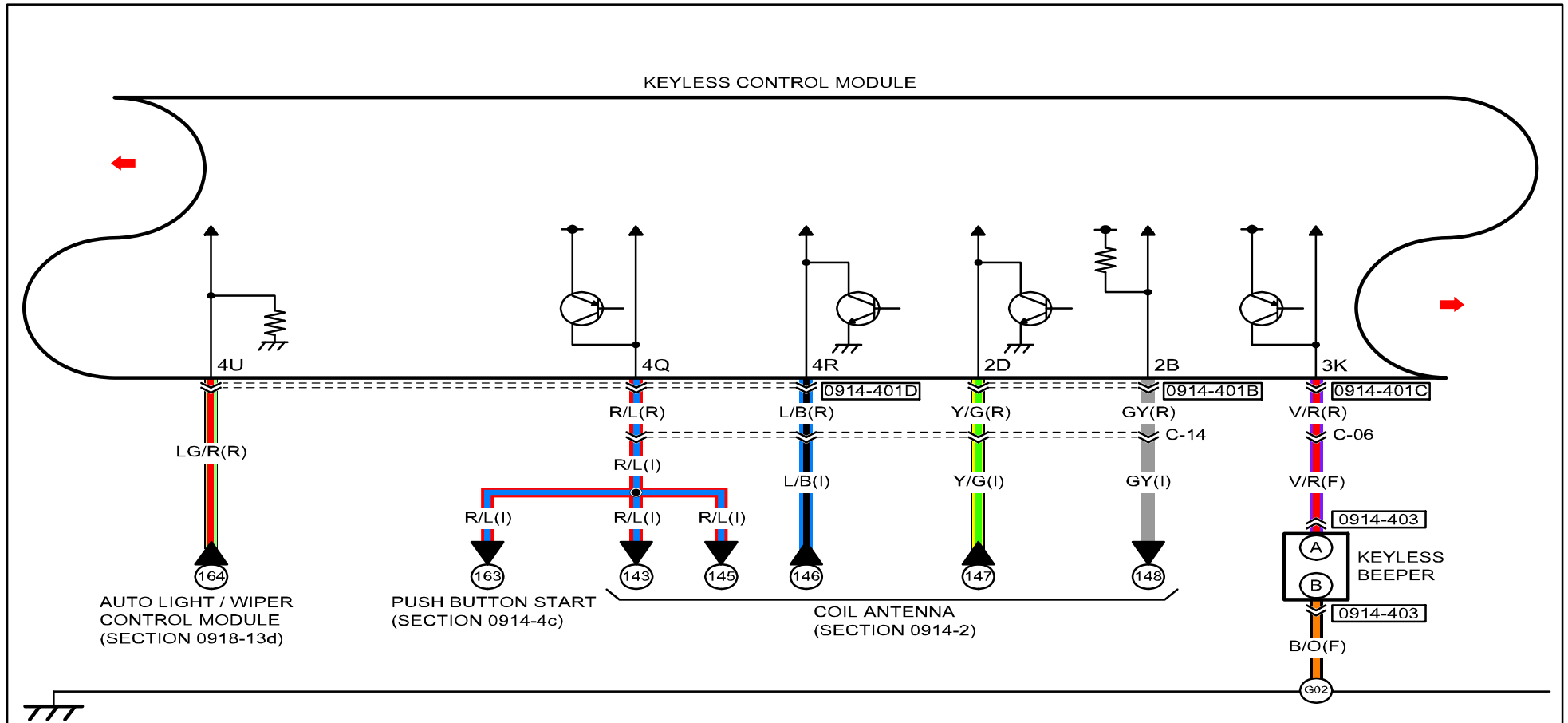

ADVANCED KEYLESS ENTRY AND PUSH BUTTON START SYSTEM

0914-4d

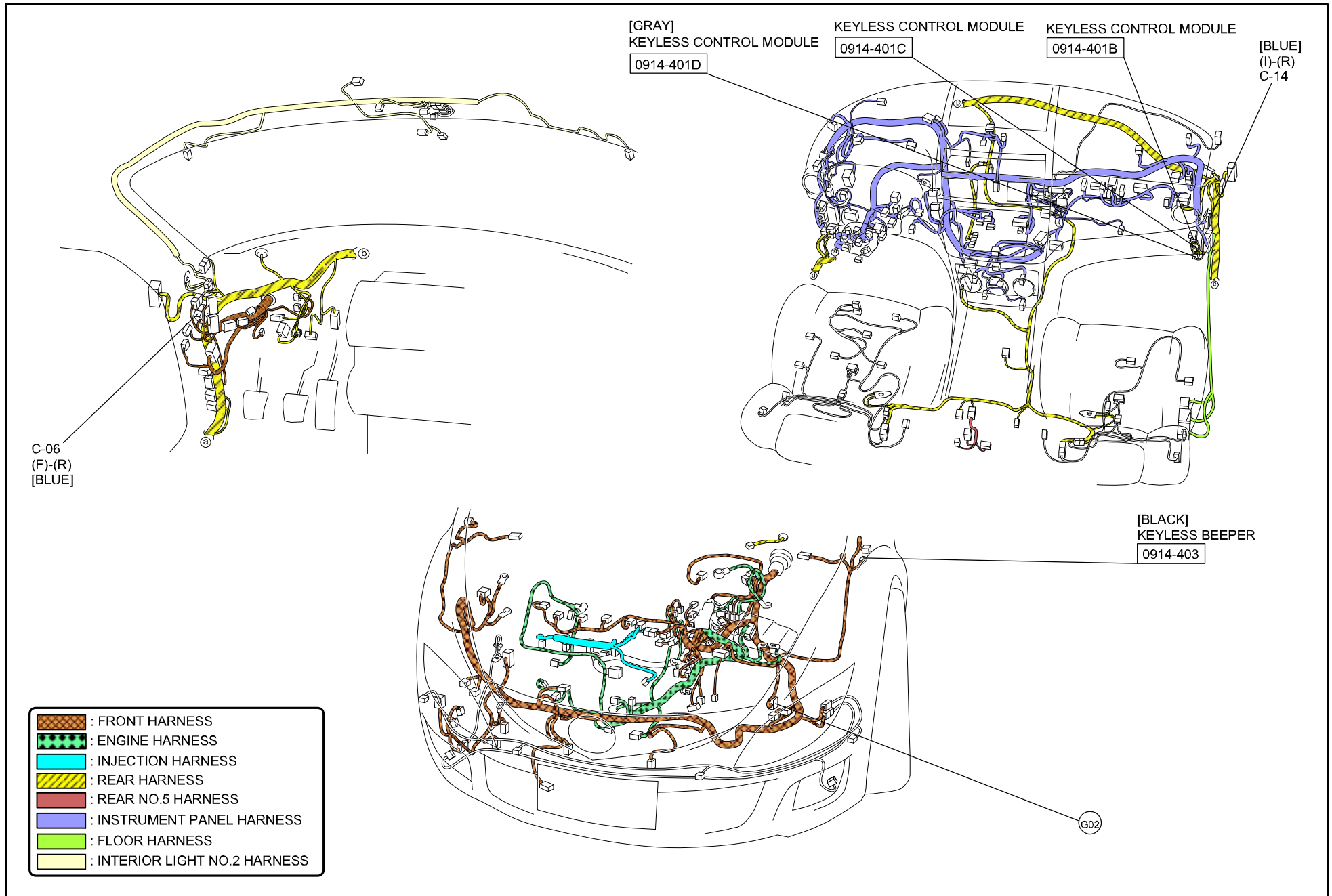

C-06

FRONT HARNESS-REAR HARNESS

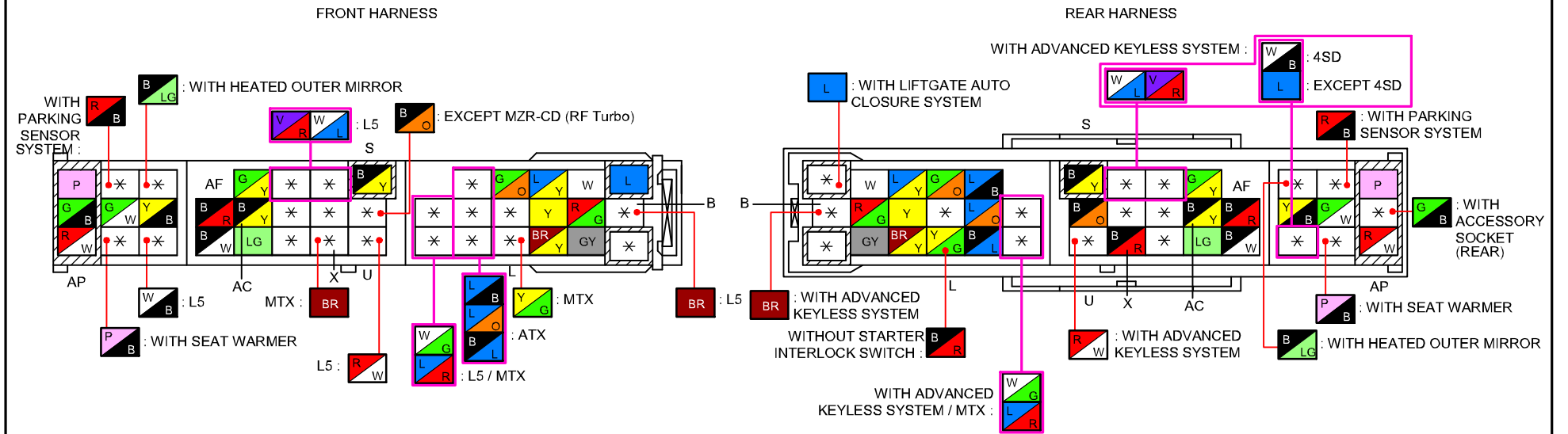

C-14

INSTRUMENT PANEL HARNESS-REAR HARNESS

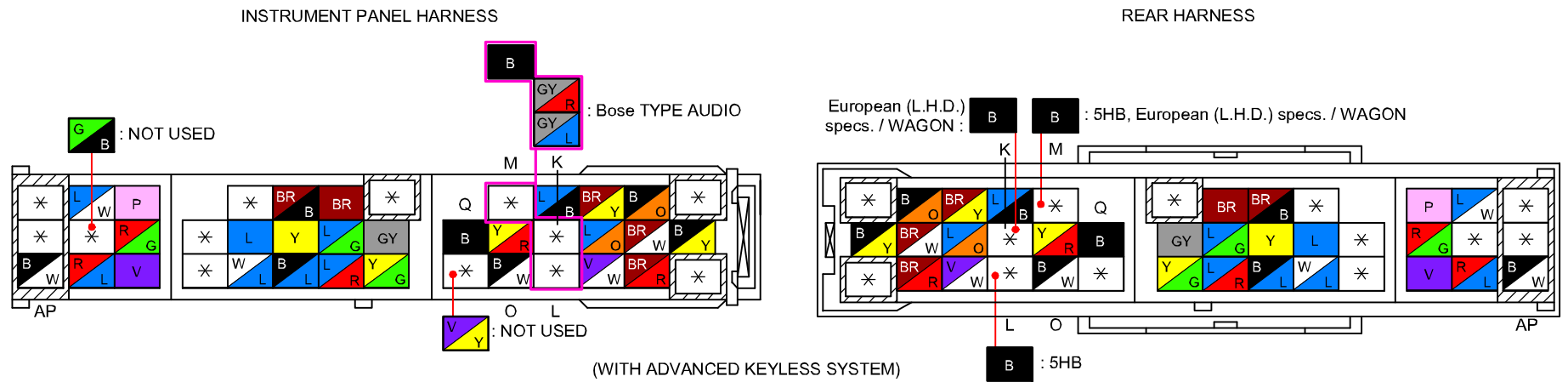

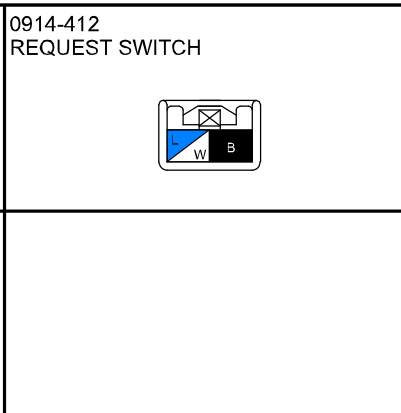
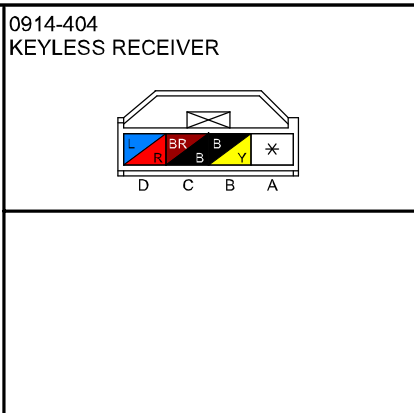
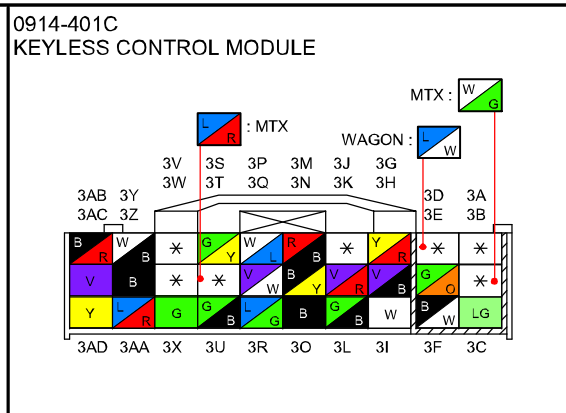
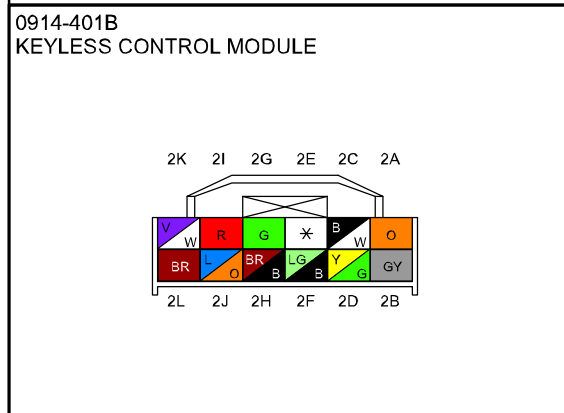
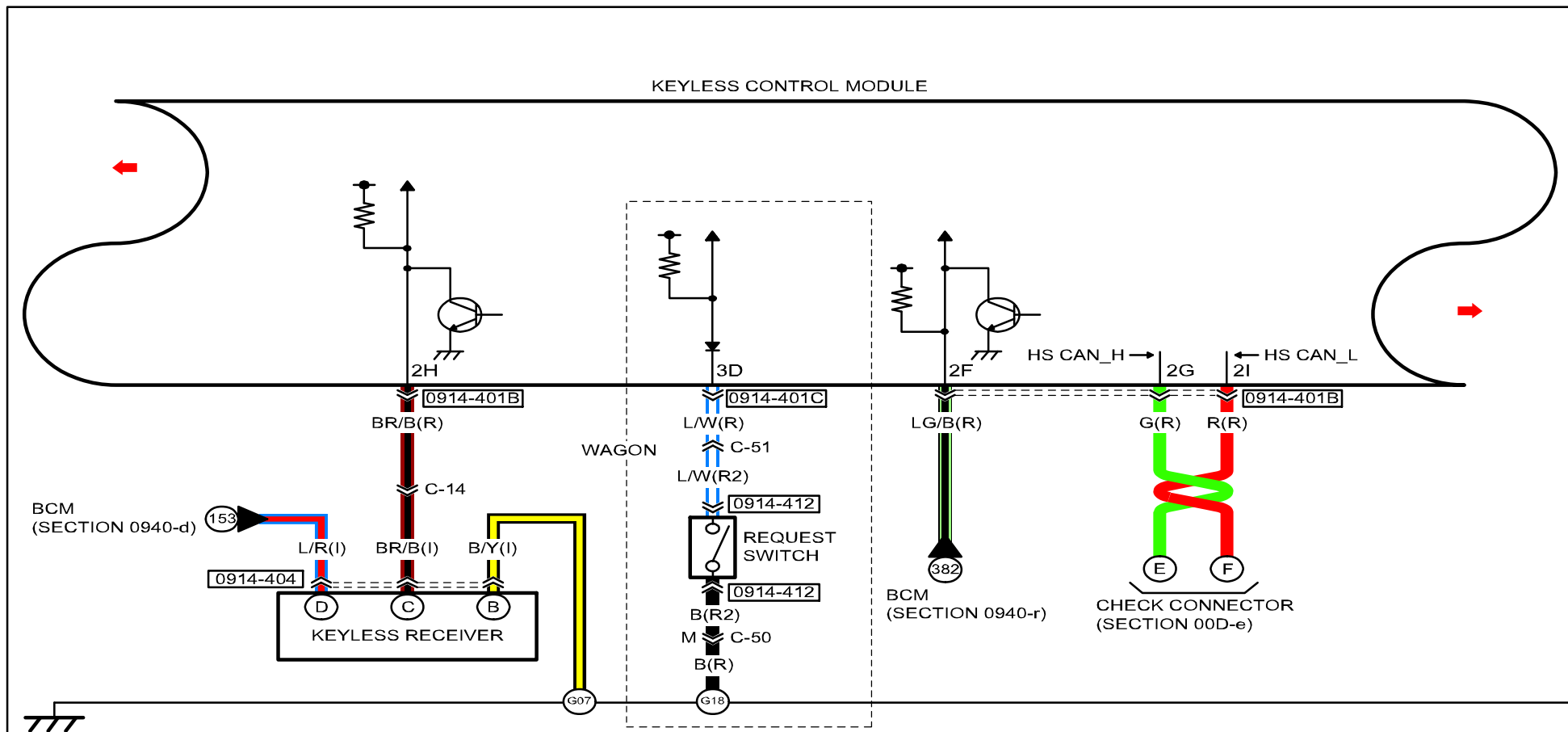

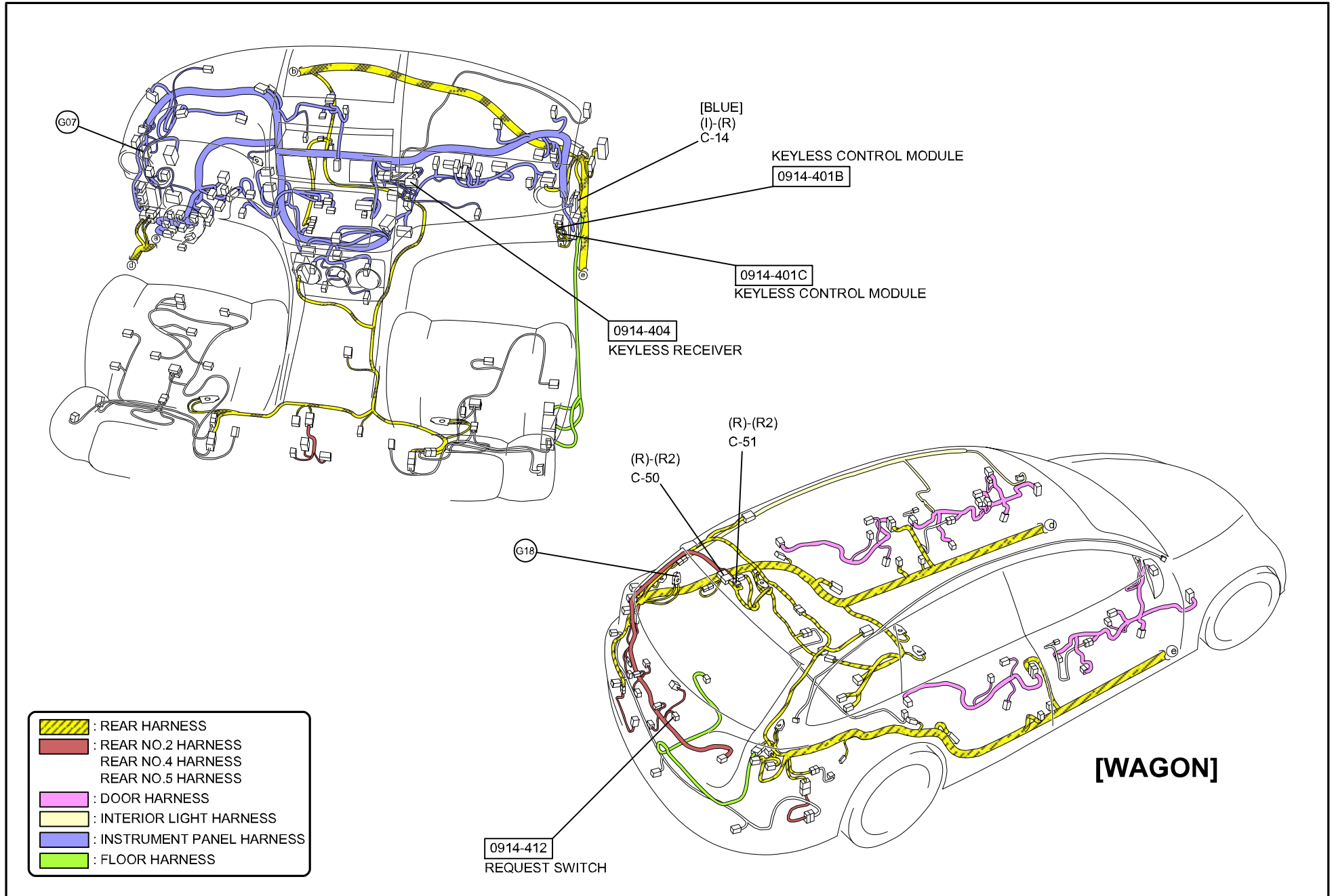

C-14
INSTRUMENT PANEL HARNESS-REAR HARNESS

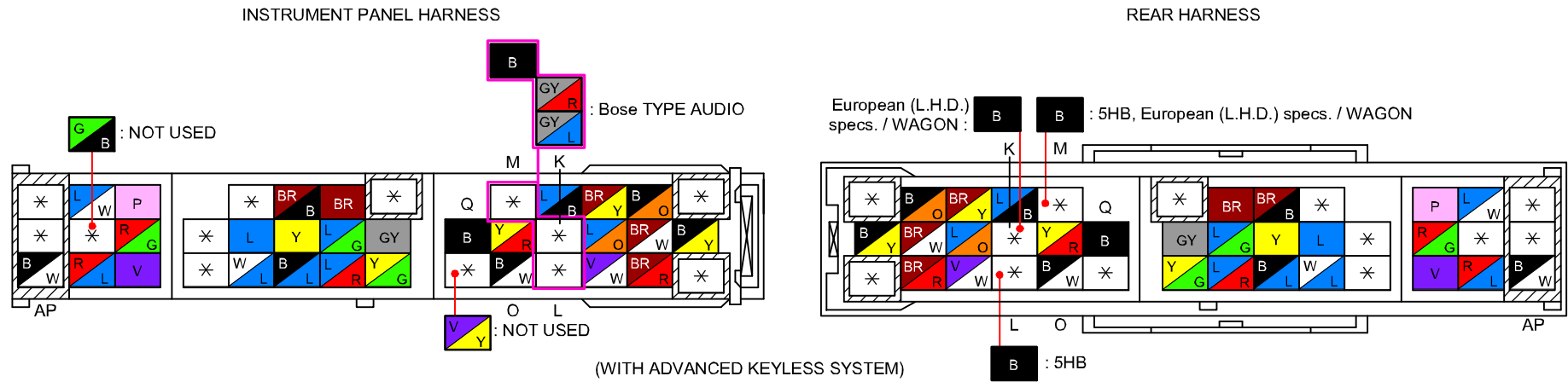

C-50
REAR HARNESS-REAR NO.2 HARNESS

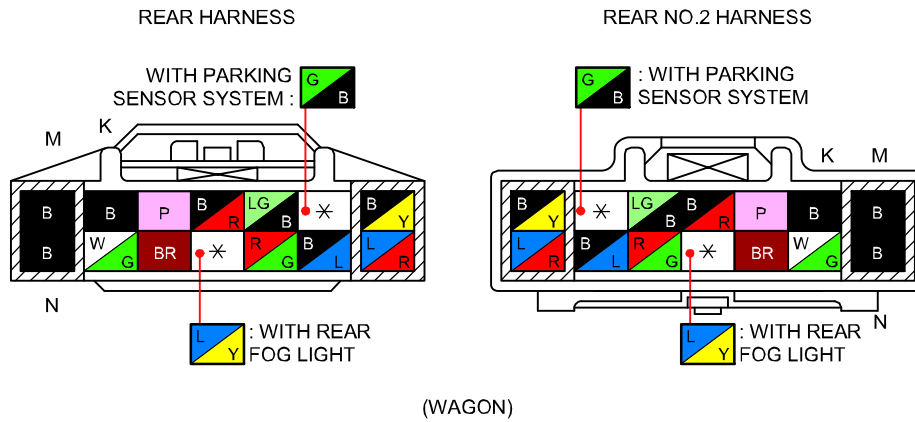

C-51
REAR HARNESS-REAR NO.2 HARNESS

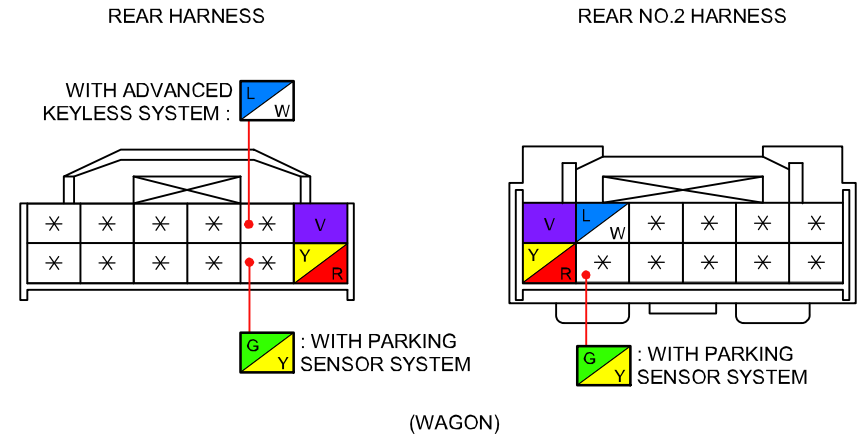

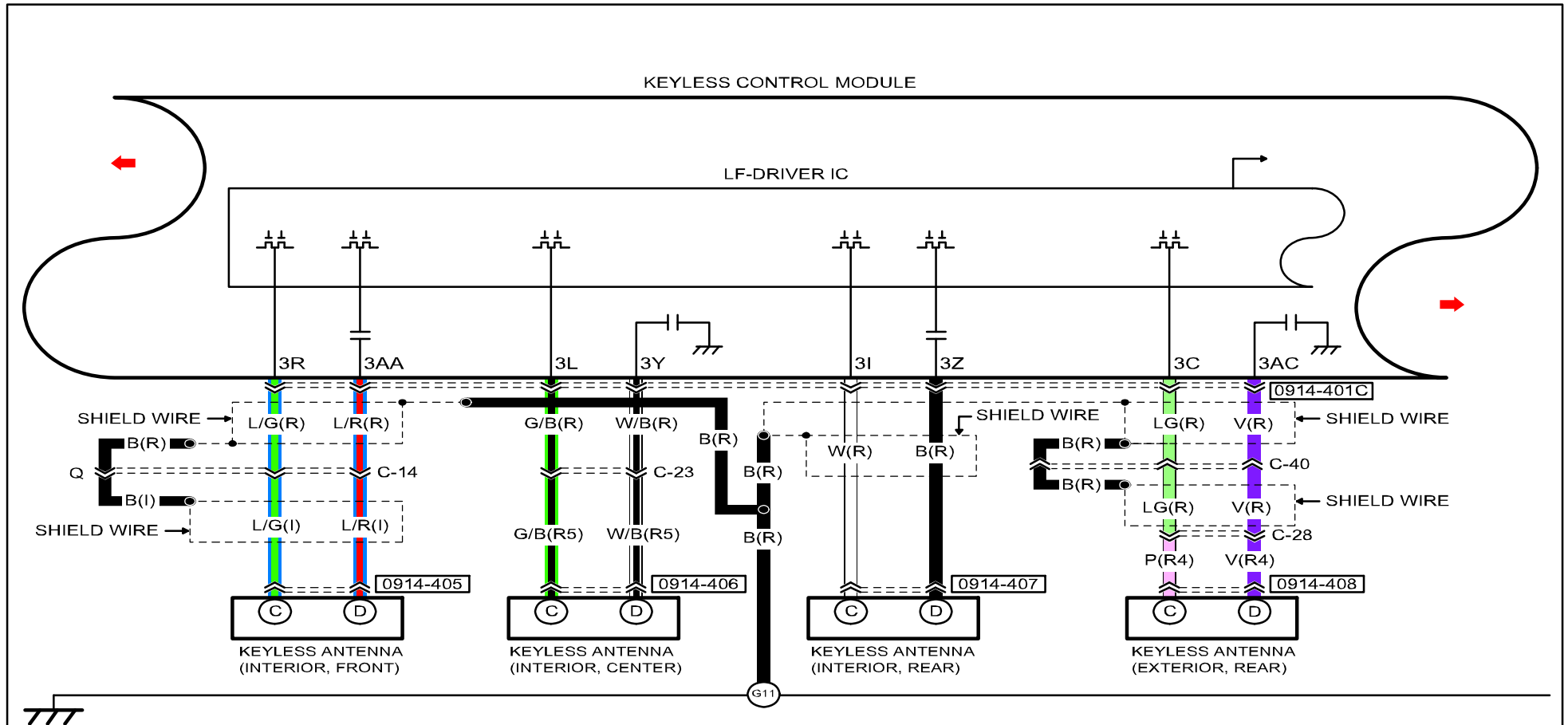

0914-401C KEYLESS CONTROL MODULE	0914-405 KEYLESS ANTENNA (INTERIOR, FRONT)	0914-406 KEYLESS ANTENNA (INTERIOR, CENTER)	0914-407 KEYLESS ANTENNA (INTERIOR, REAR)	0914-408 KEYLESS ANTENNA (EXTERIOR, REAR)
<p>Terminal block diagram for the Keyless Control Module. The diagram shows terminals 3AB, 3Y, 3W, 3S, 3P, 3M, 3J, 3G, 3T, 3Q, 3N, 3K, 3H, 3D, 3A, 3E, 3B, 3F, and 3C. Each terminal is connected to a specific wire color: 3AB (B), 3Y (R), 3W (W), 3S (L), 3P (G), 3M (Y), 3J (R), 3G (B), 3T (W), 3Q (V), 3N (P), 3K (V), 3H (R), 3D (G), 3A (O), 3E (W), 3B (LG), 3F (B), and 3C (W).</p>	<p>Terminal block diagram for Antenna 0914-405. The diagram shows terminals D, C, B, and A. The wire colors are: D (L), C (R), B (G), and A (B).</p>	<p>Terminal block diagram for Antenna 0914-406. The diagram shows terminals D, C, B, and A. The wire colors are: D (W), C (G), B (B), and A (B).</p>	<p>Terminal block diagram for Antenna 0914-407. The diagram shows terminals D, C, B, and A. The wire colors are: D (B), C (W), B (B), and A (B).</p>	<p>Terminal block diagram for Antenna 0914-408. The diagram shows terminals D, C, B, and A. The wire colors are: D (V), C (P), B (V), and A (B).</p>

ADVANCED KEYLESS ENTRY AND PUSH BUTTON START SYSTEM

0914-4f

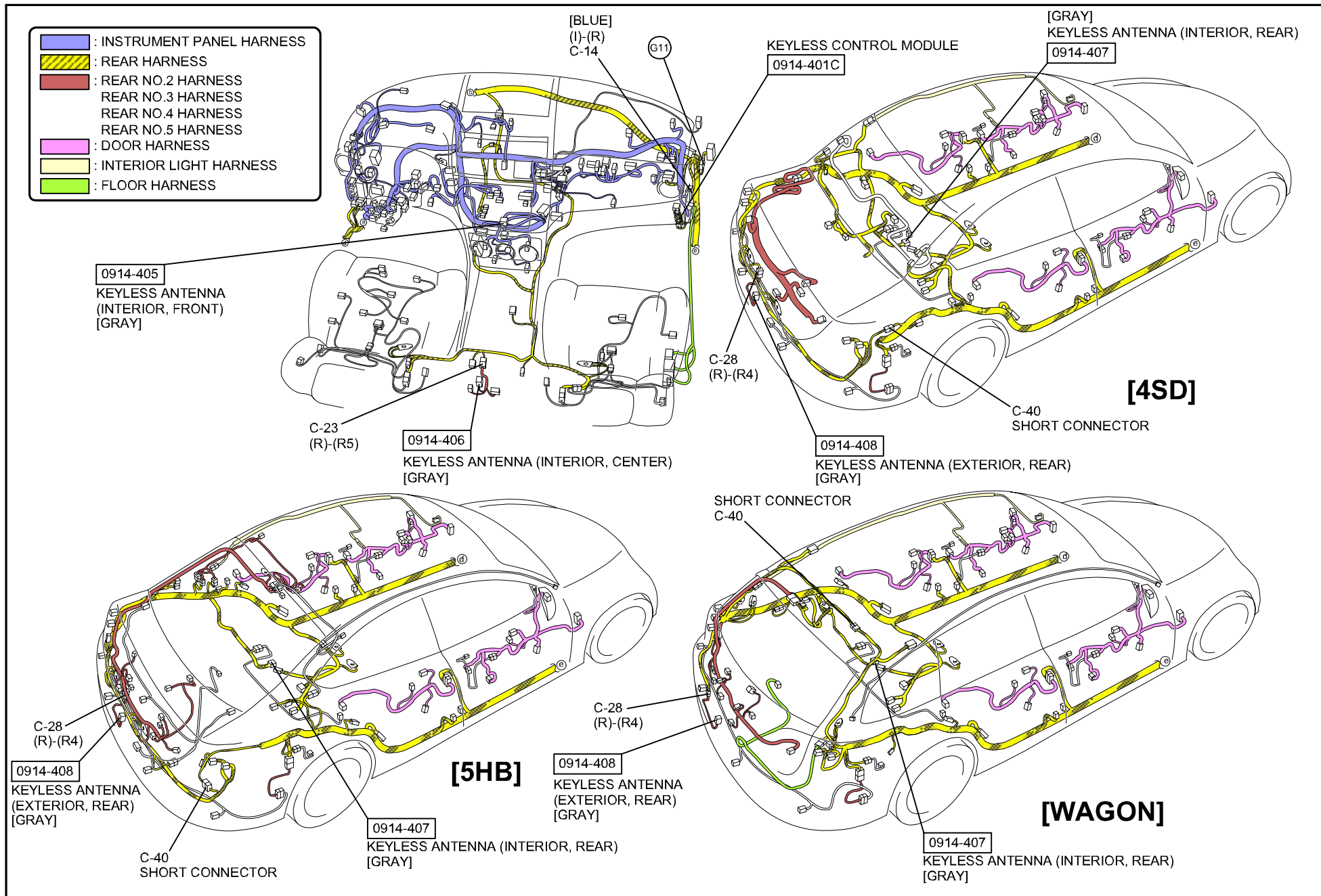

C-14
INSTRUMENT PANEL HARNESS-REAR HARNESS

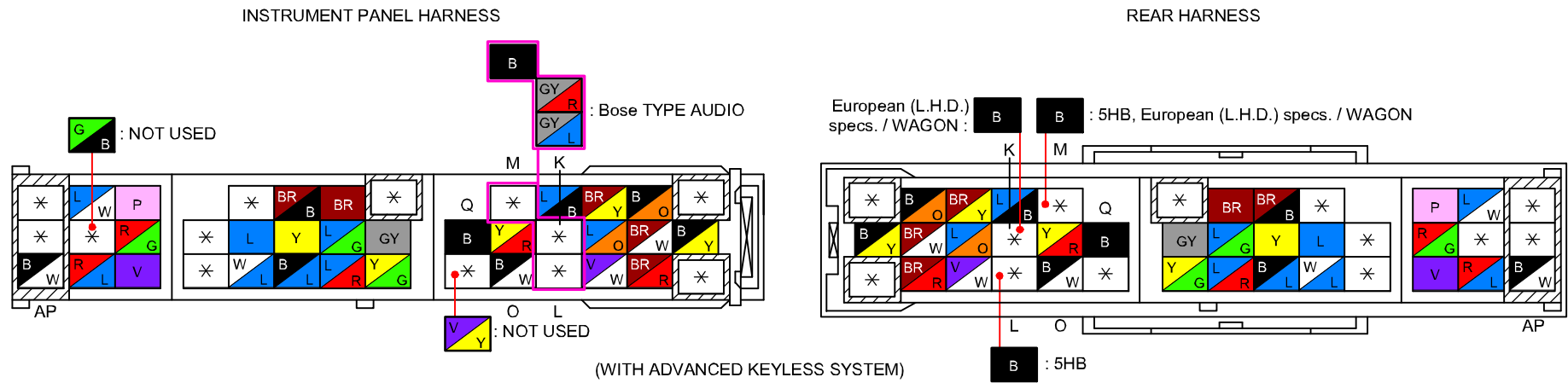

C-23
REAR HARNESS-REAR NO.5 HARNESS

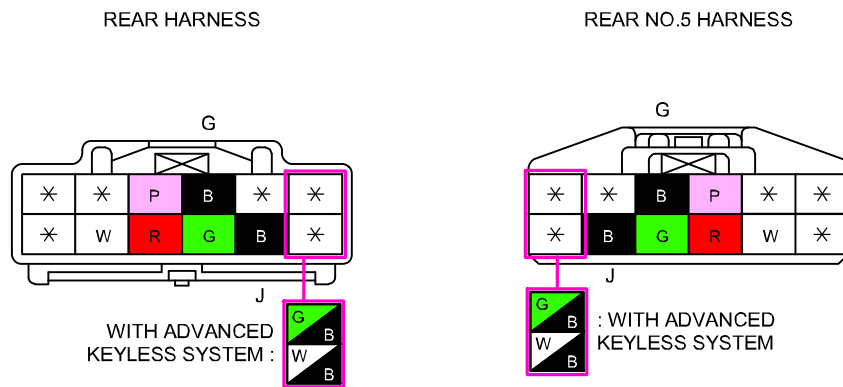

C-28
REAR HARNESS-REAR NO.4 HARNESS

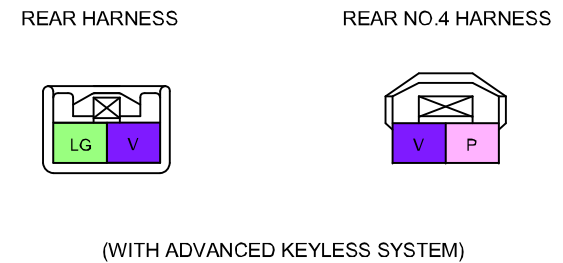

C-40
SHORT CONNECTOR

REAR HARNESS

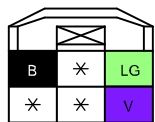

(4SD / WITH ADVANCED KEYLESS SYSTEM)

REAR HARNESS

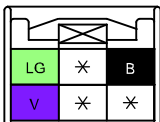

REAR HARNESS

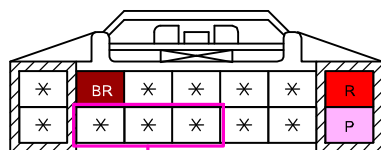

(5HB)

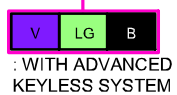

REAR HARNESS

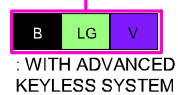
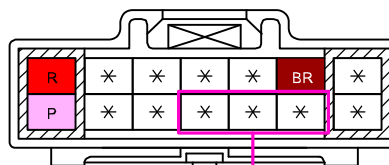

REAR HARNESS

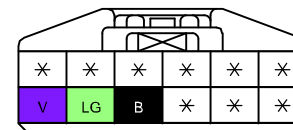

(WAGON / WITH ADVANCED KEYLESS SYSTEM)

REAR HARNESS

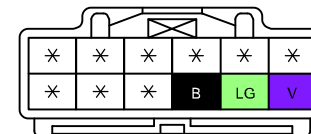

C-29

REAR HARNESS-DOOR NO.1 HARNESS

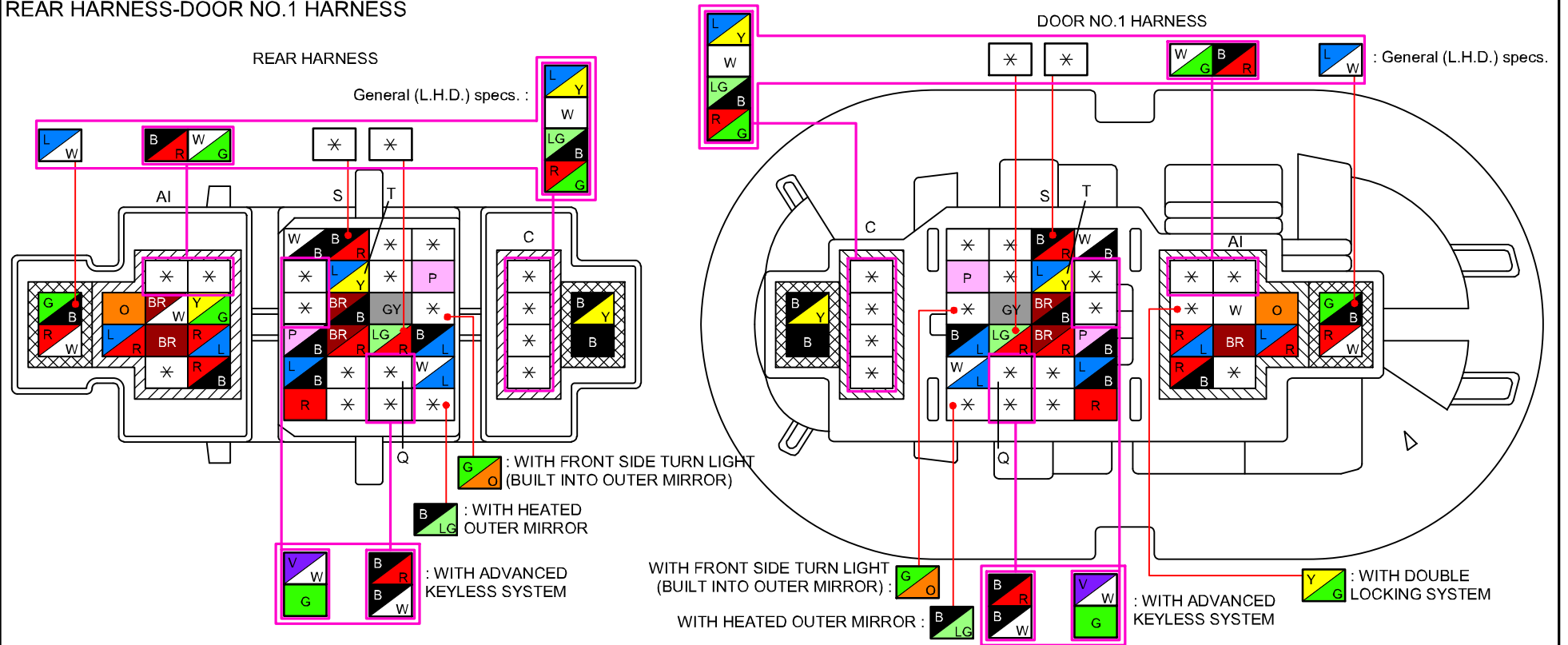

C-45

DOOR NO.1 HARNESS-SHORT CORD

DOOR NO.1 HARNESS

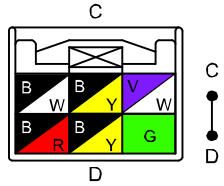

SHORT CORD

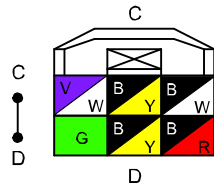

(WITH ADVANCED KEYLESS SYSTEM)

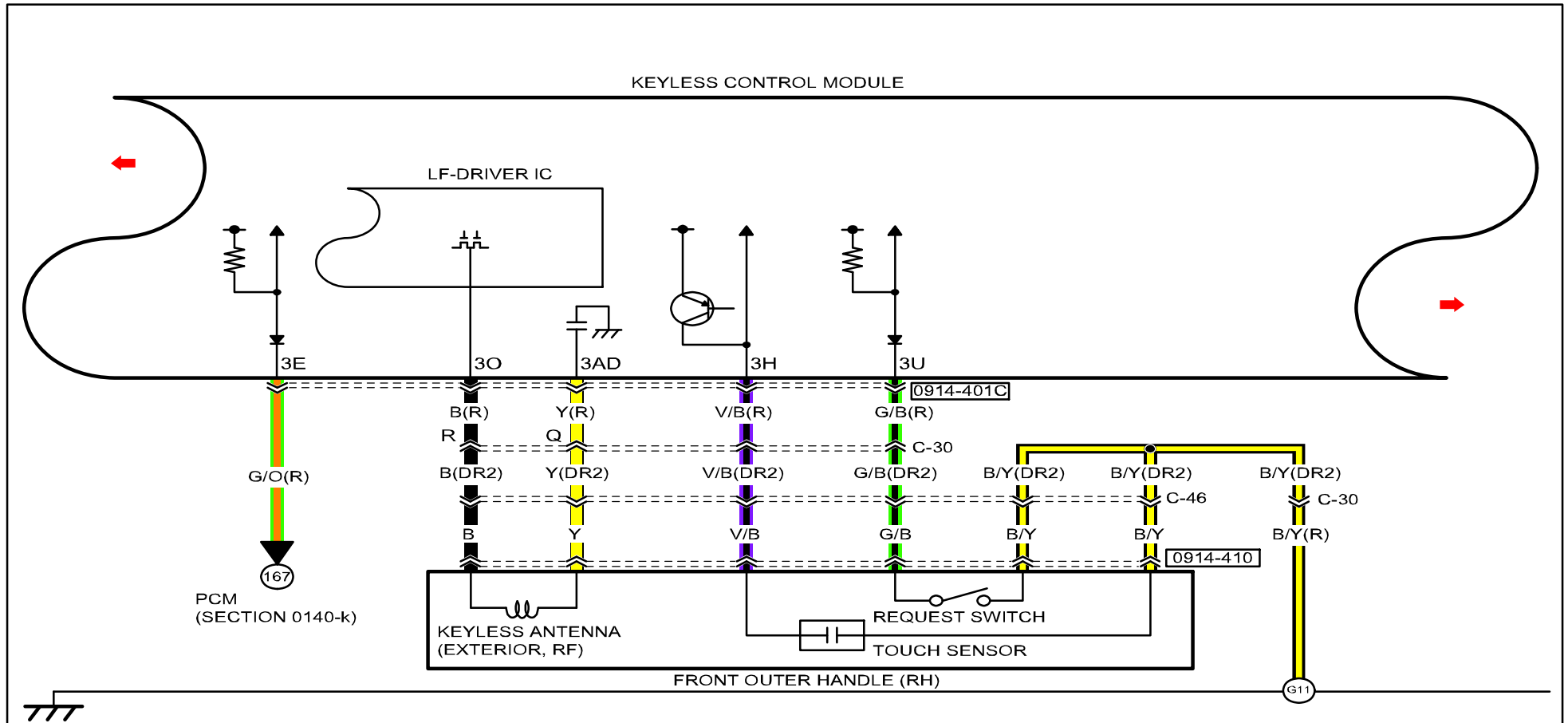

<p>0914-401C KEYLESS CONTROL MODULE</p>	<p>0914-410 FRONT OUTER HANDLE (RH)</p>			
---	---	--	--	--

ADVANCED KEYLESS ENTRY AND PUSH BUTTON START SYSTEM

0914-4h

- : INSTRUMENT PANEL HARNESS
- : REAR HARNESS
- : REAR NO.2 HARNESS
- : REAR NO.3 HARNESS
- : REAR NO.4 HARNESS
- : REAR NO.5 HARNESS
- : DOOR HARNESS
- : INTERIOR LIGHT HARNESS
- : FLOOR HARNESS

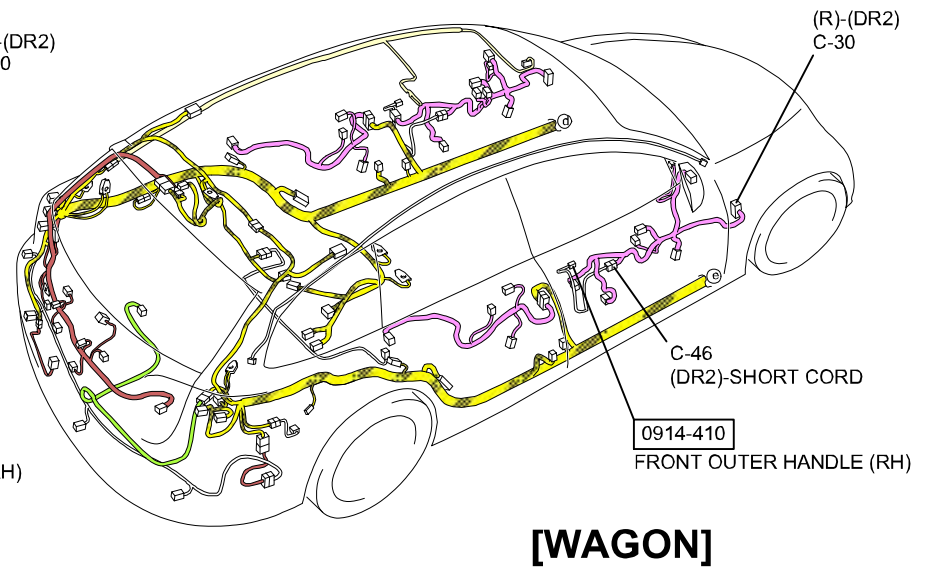
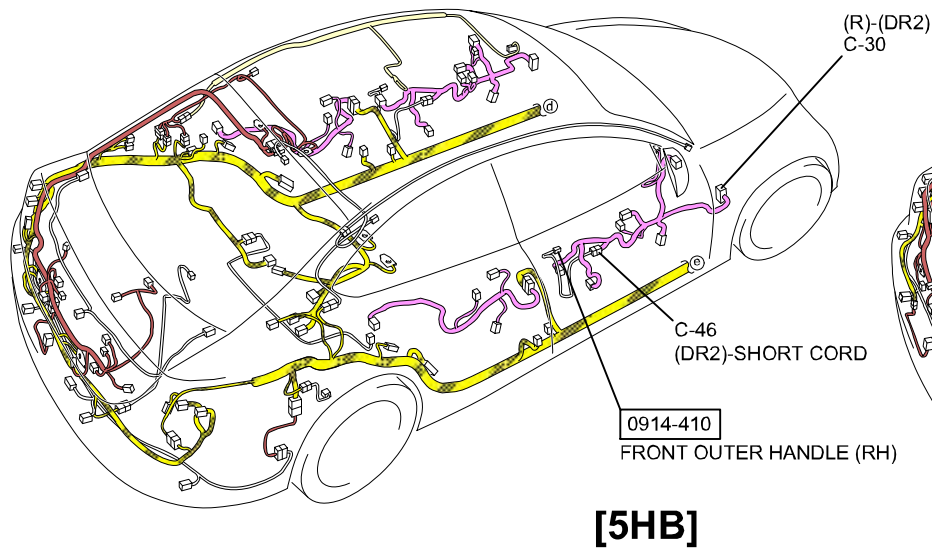
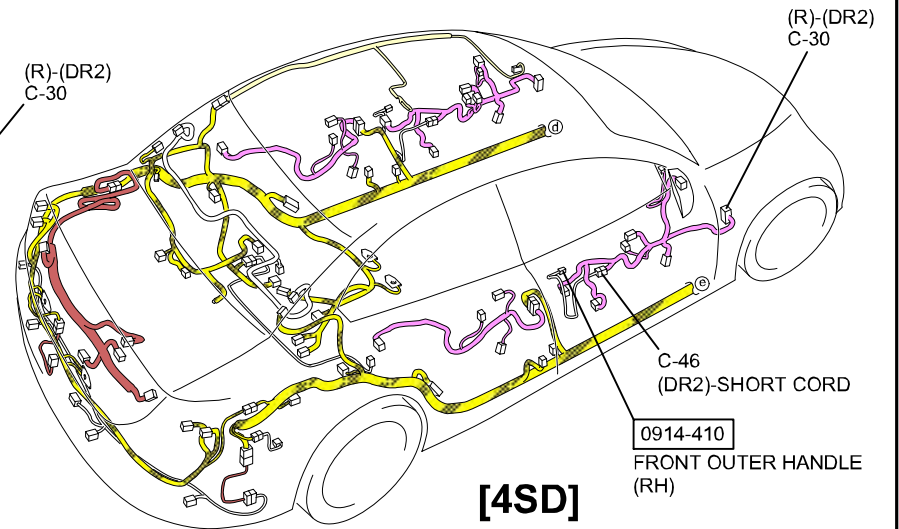
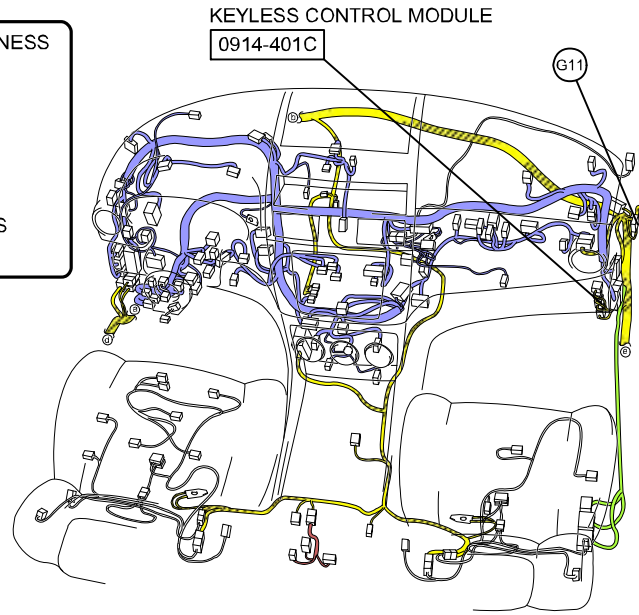

C-30
REAR HARNESS-DOOR NO.2 HARNESS

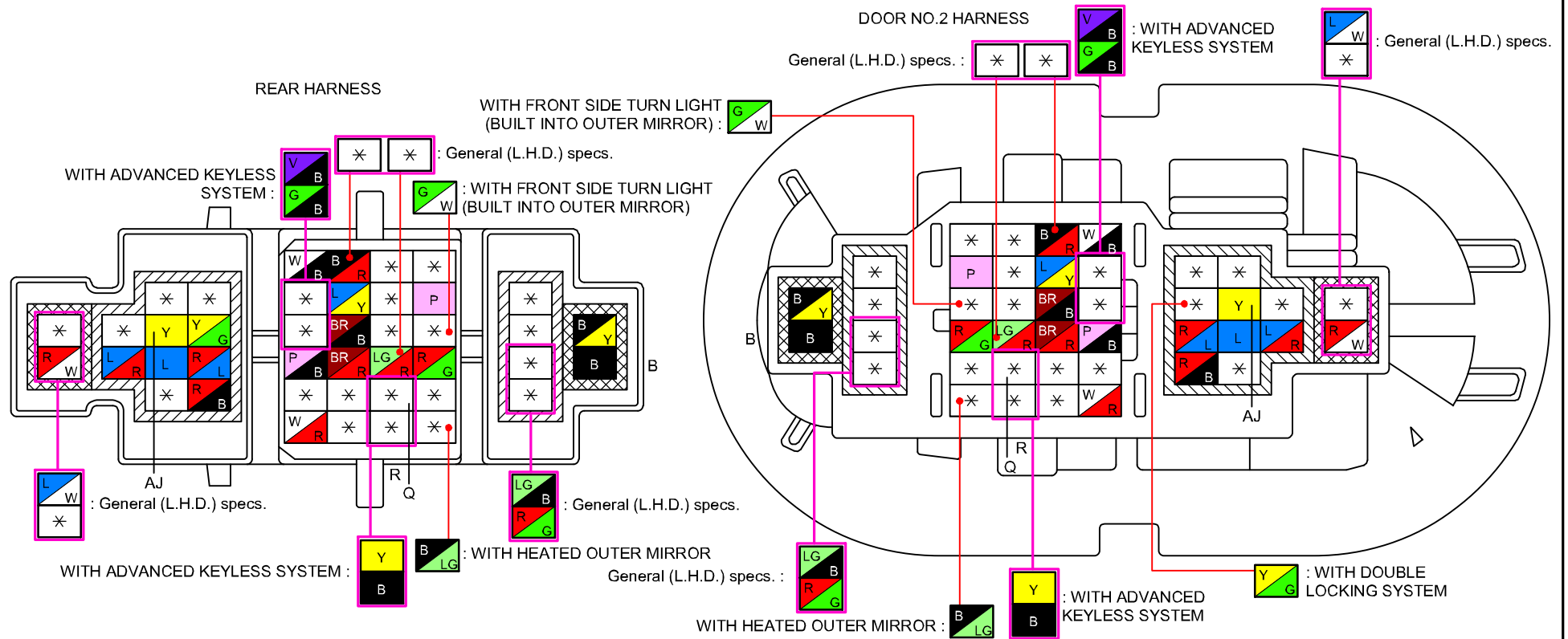

C-46

DOOR NO.2 HARNESS-SHORT CORD

DOOR NO.2 HARNESS

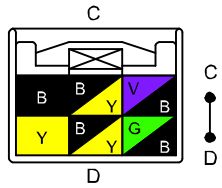



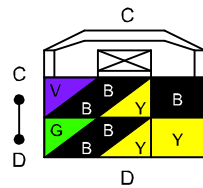

SHORT CORD

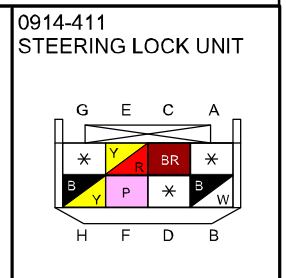
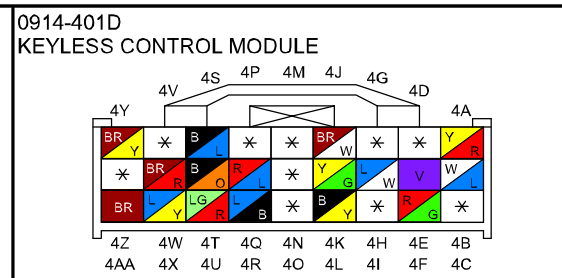
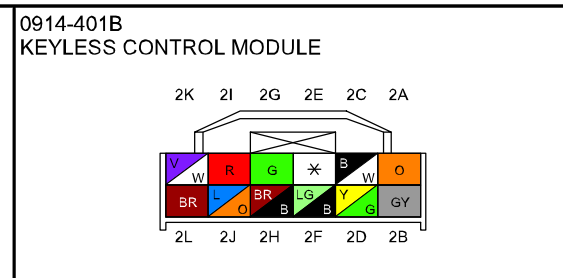
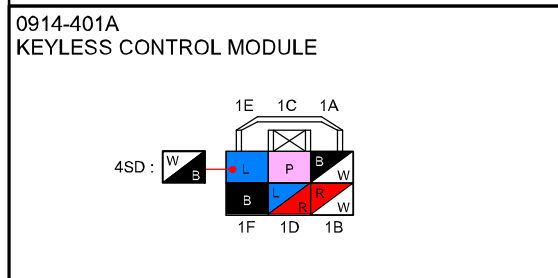
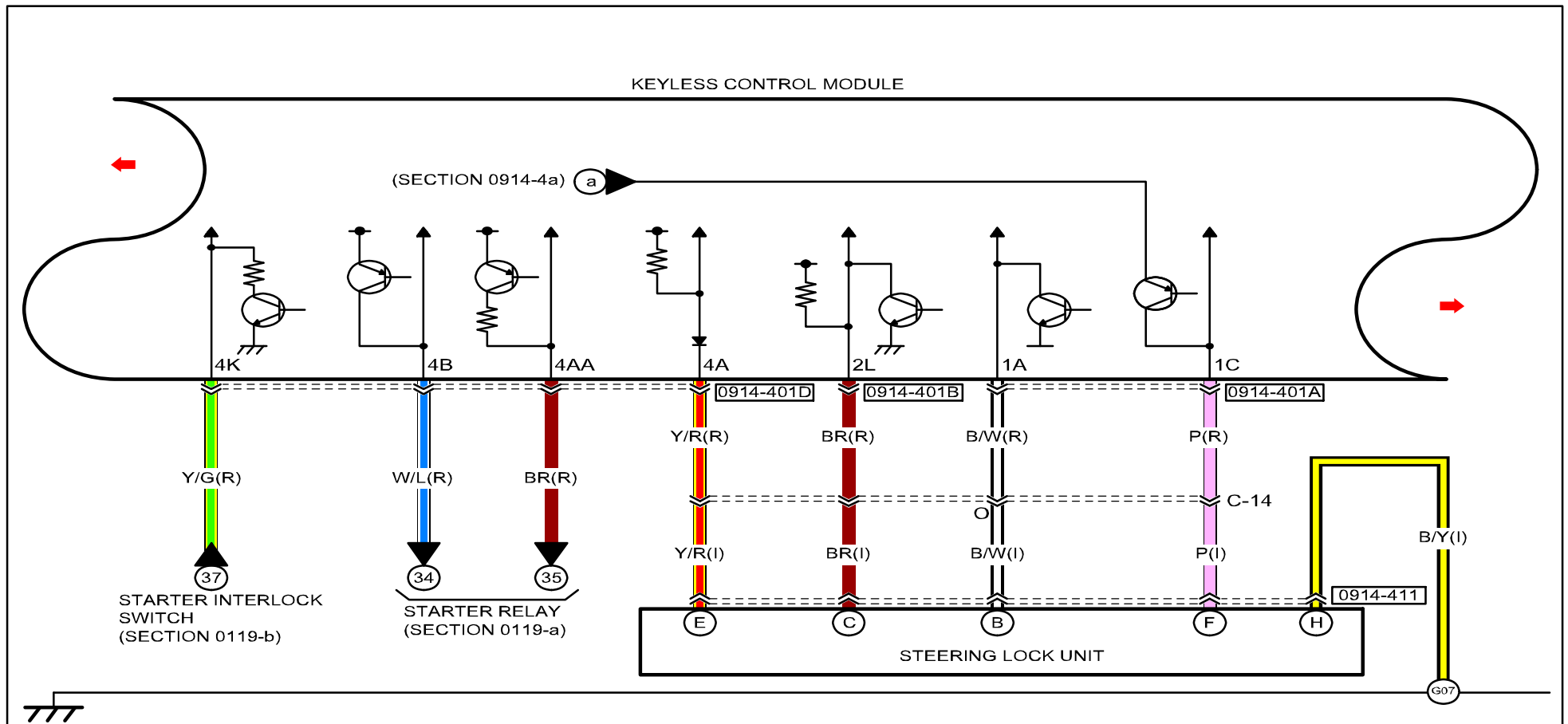

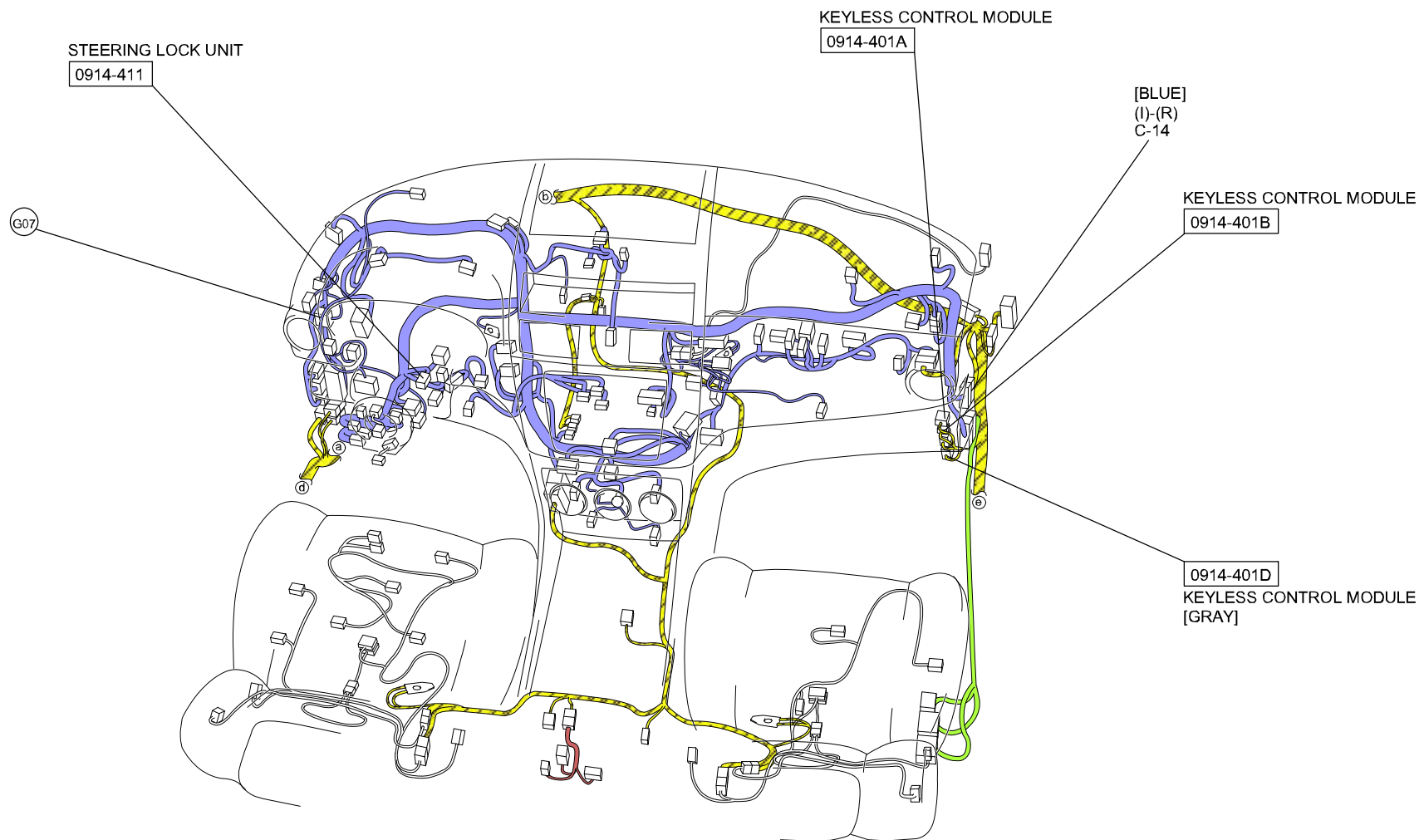
(WITH ADVANCED KEYLESS SYSTEM)





-  : REAR HARNESS
-  : REAR NO.5 HARNESS
-  : INSTRUMENT PANEL HARNESS
-  : FLOOR HARNESS

C-14

INSTRUMENT PANEL HARNESS-REAR HARNESS

INSTRUMENT PANEL HARNESS

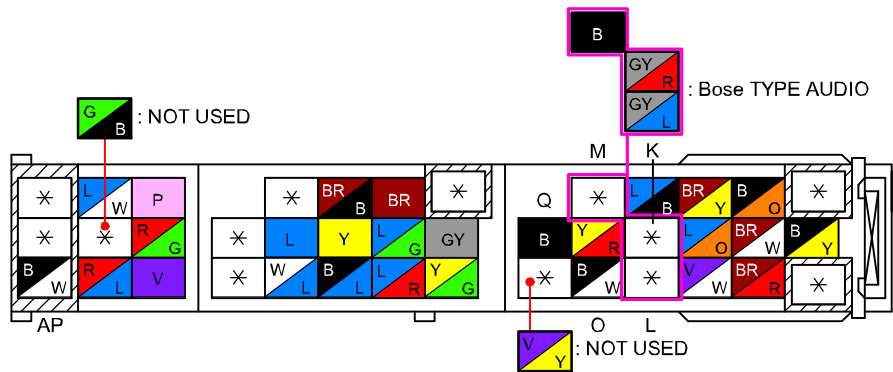

(WITH ADVANCED KEYLESS SYSTEM)

REAR HARNESS

European (L.H.D.) specs. / WAGON : B B : 5HB, European (L.H.D.) specs. / WAGON

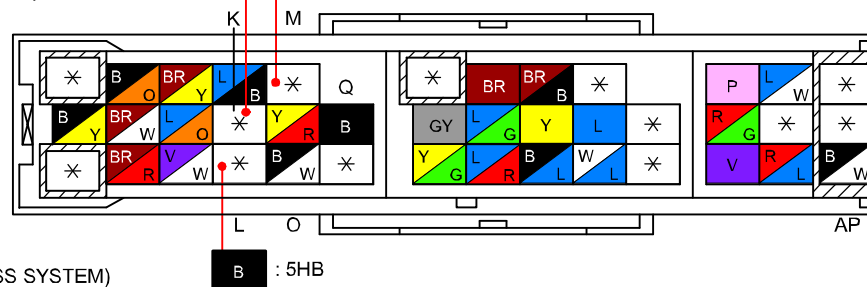

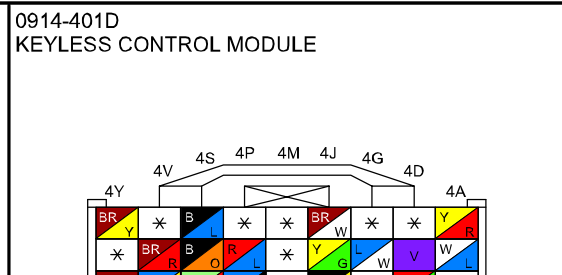
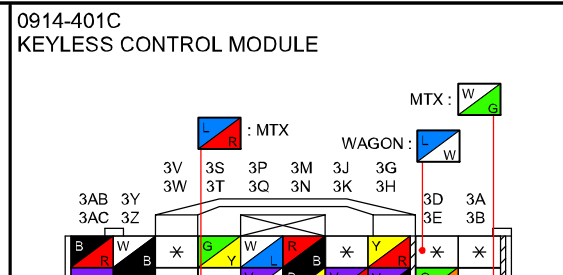
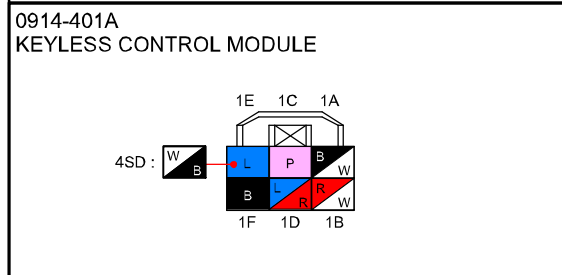
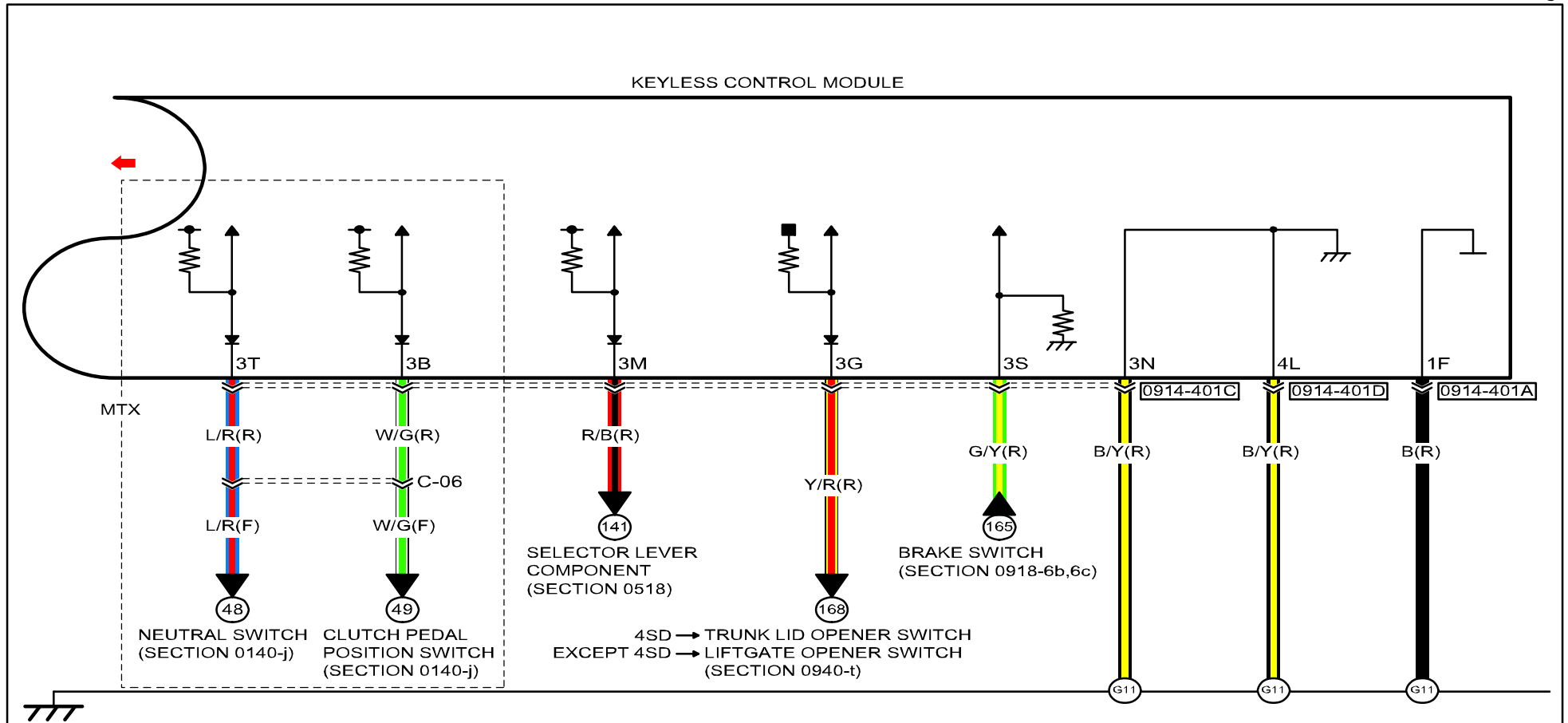

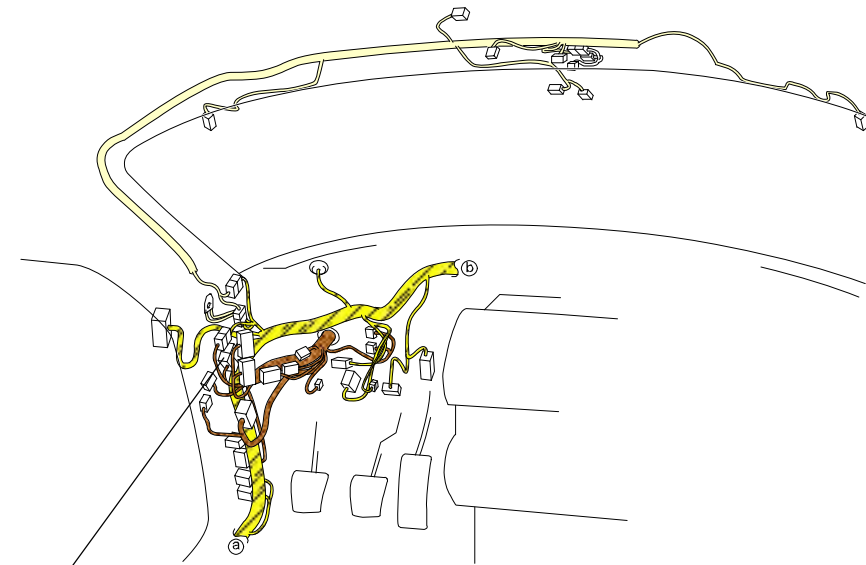

C-06
(F)-(R)
[BLUE]

[GRAY]
KEYLESS CONTROL MODULE
0914-401D

KEYLESS CONTROL MODULE
0914-401C

KEYLESS CONTROL MODULE
0914-401A

G11

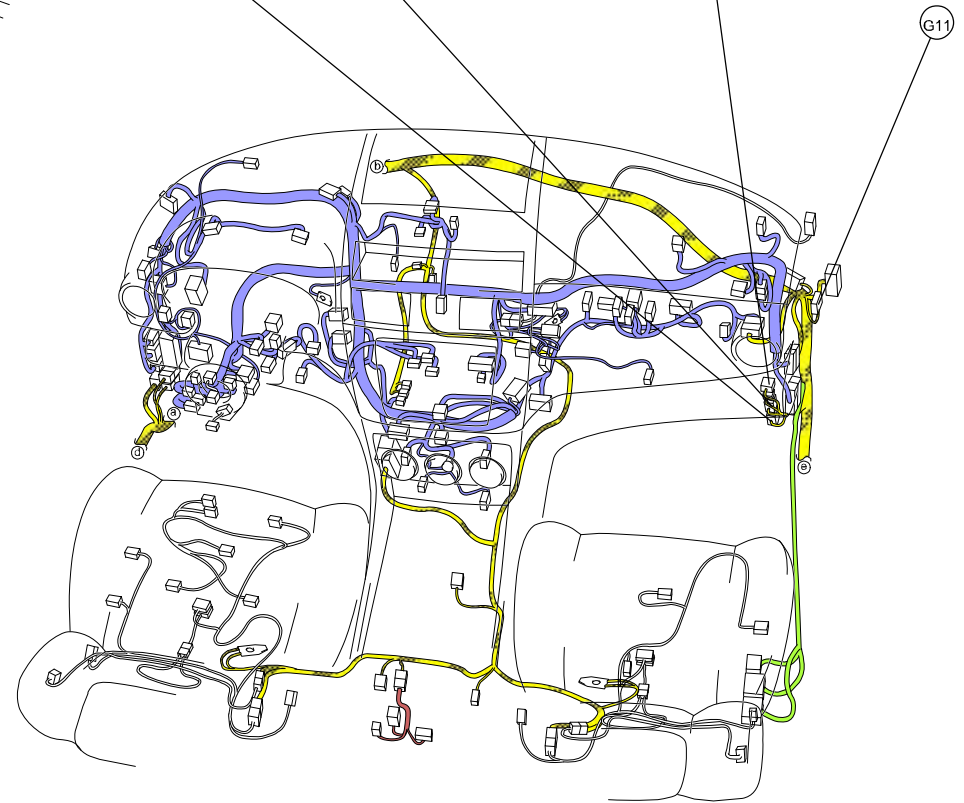

- : FRONT HARNESS
- : REAR HARNESS
- : REAR NO.5 HARNESS
- : INSTRUMENT PANEL HARNESS
- : FLOOR HARNESS
- : INTERIOR LIGHT NO.2 HARNESS

C-06

FRONT HARNESS-REAR HARNESS

FRONT HARNESS

REAR HARNESS

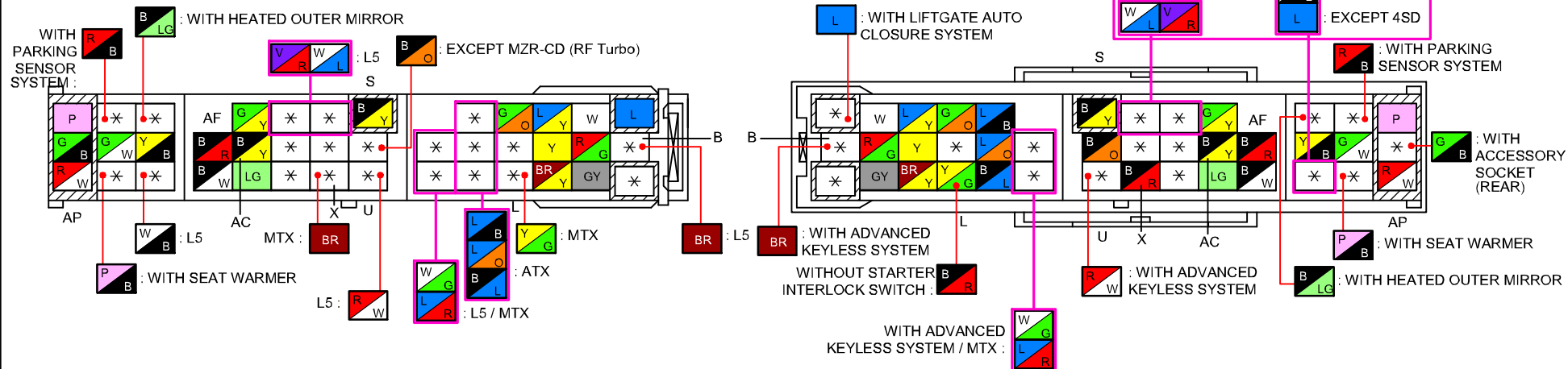

LIFTGATE AUTO CLOSURE SYSTEM

0914-5a

&5 : MZR-CD (RF Turbo)

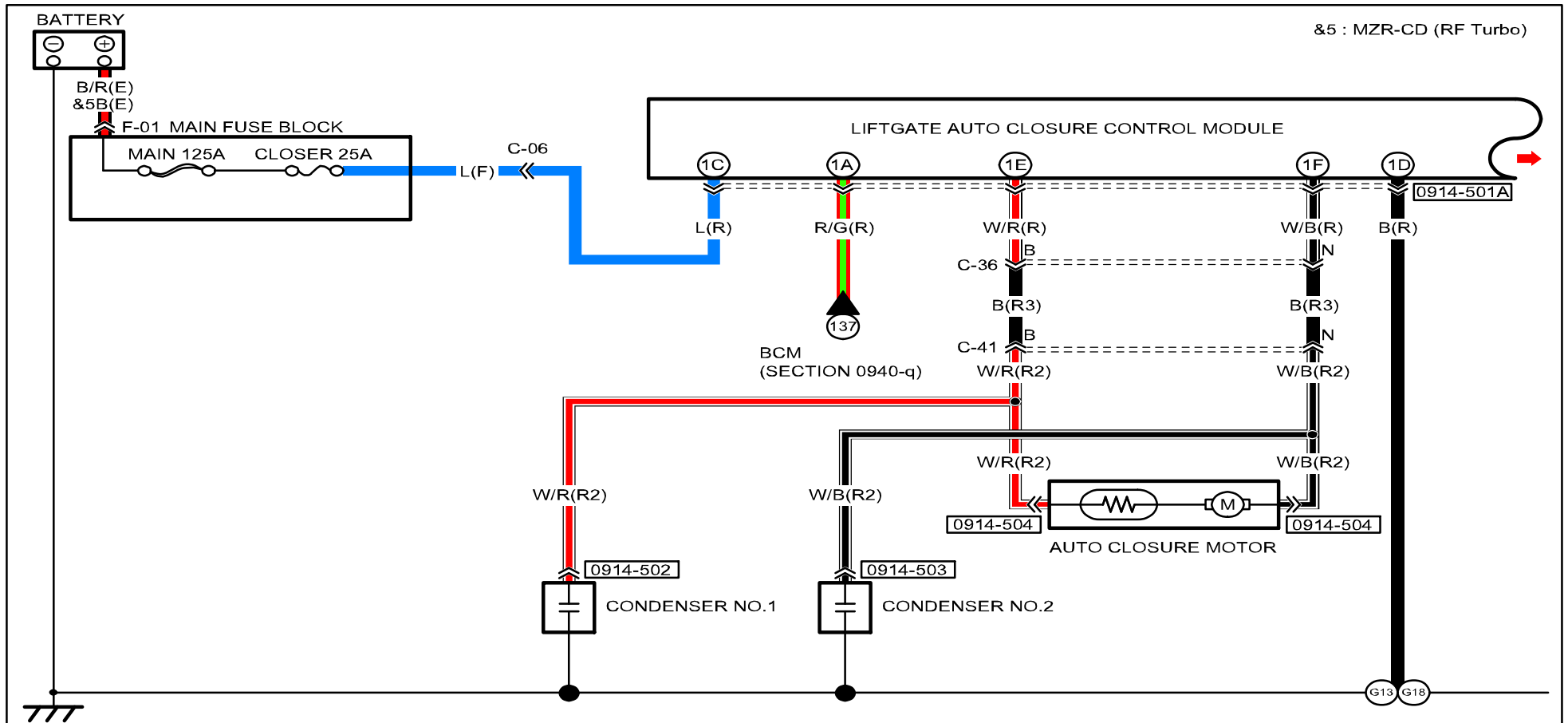

<p>0914-501A LIFTGATE AUTO CLOSURE CONTROL MODULE</p>	<p>0914-502 CONDENSER NO.1</p>	<p>0914-503 CONDENSER NO.2</p>	<p>0914-504 AUTO CLOSURE MOTOR</p>

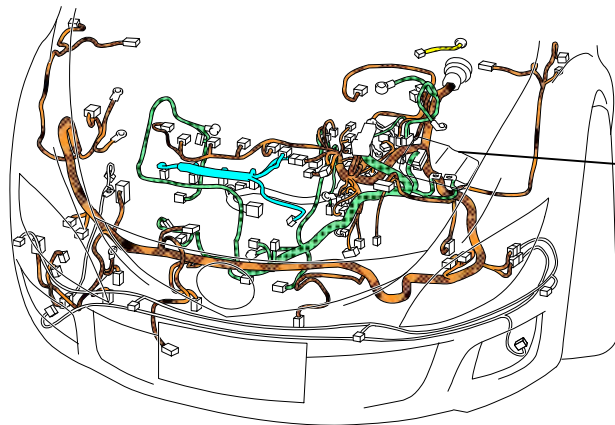

F-01
MAIN FUSE BLOCK
(REFER TO 00F SECTION)

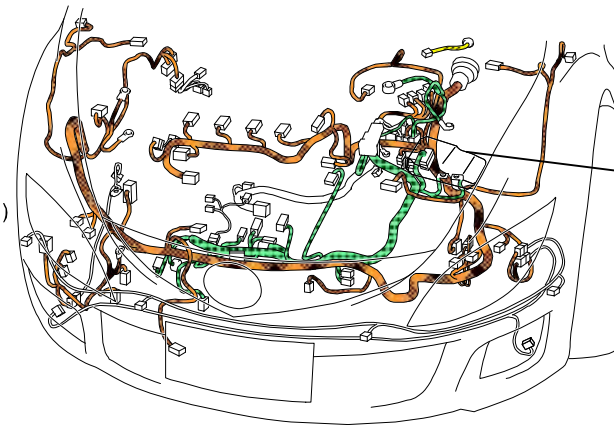

F-01
MAIN FUSE BLOCK
(REFER TO 00F SECTION)

[EXCEPT MZR-CD (RF Turbo)]

[MZR-CD (RF Turbo)]

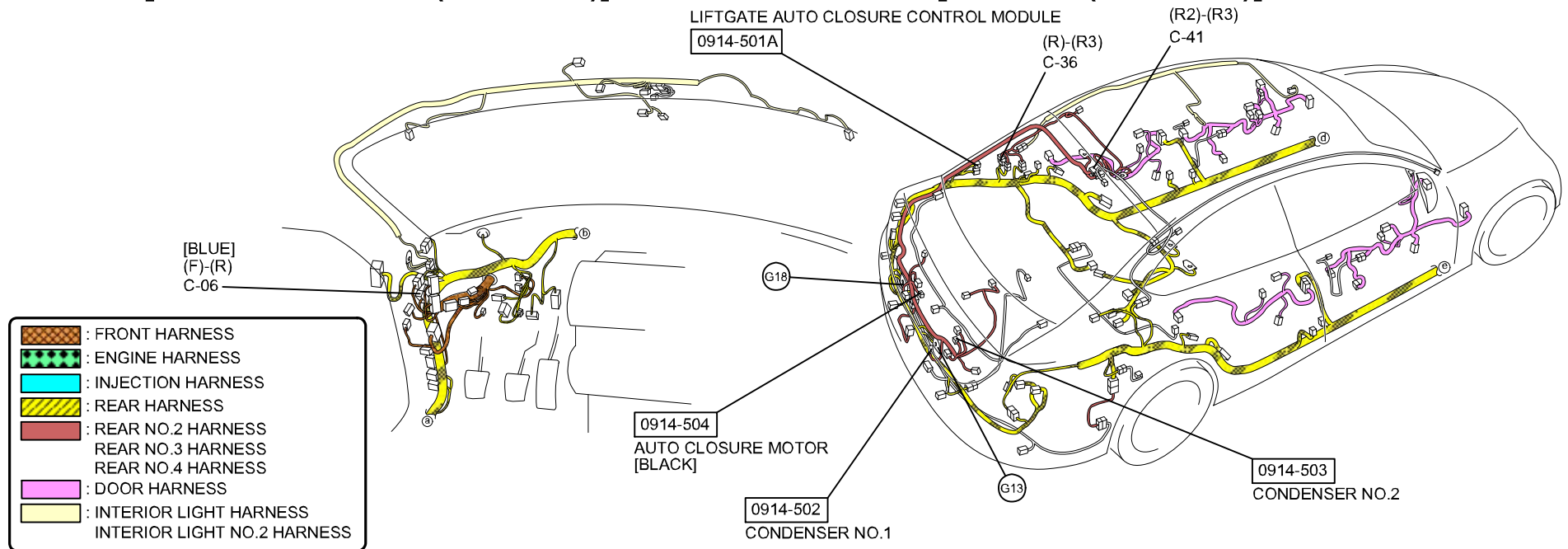

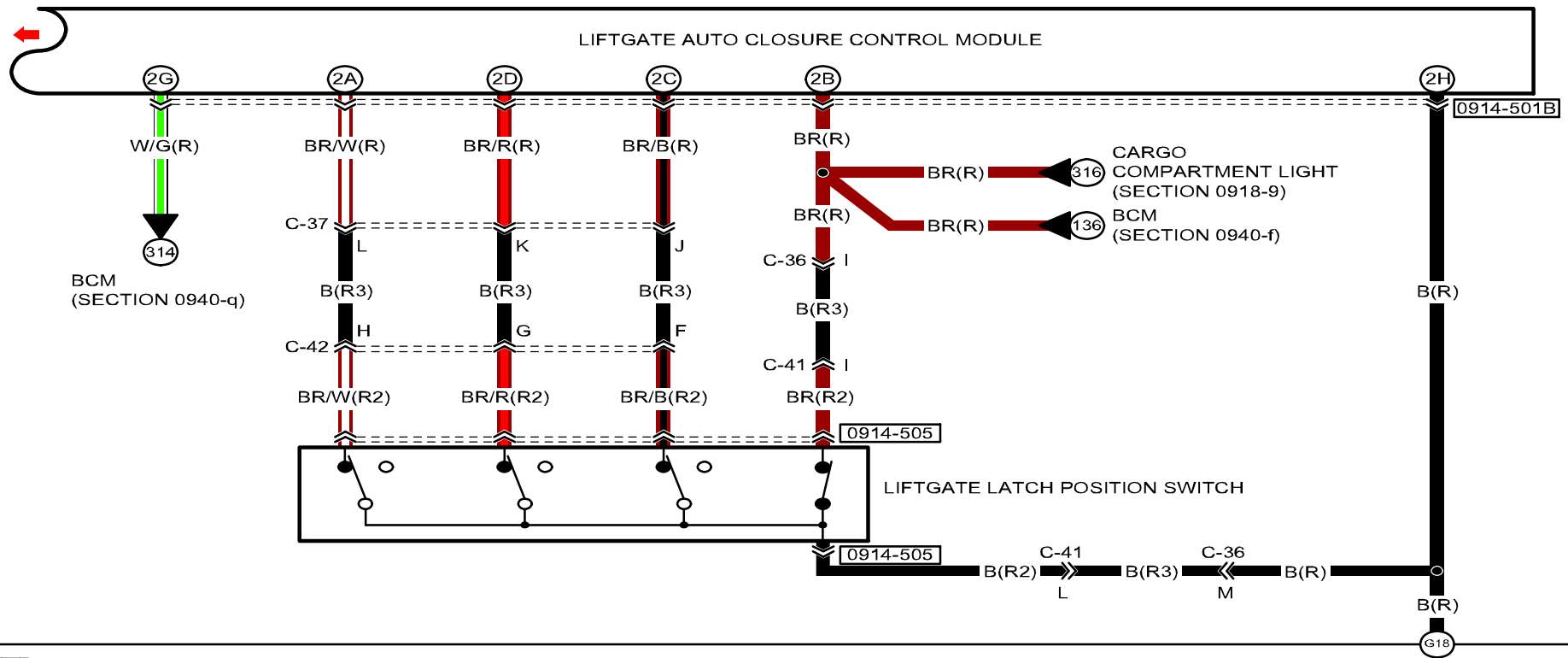

0914-501B
LIFTGATE AUTO CLOSURE CONTROL MODULE

0914-505
LIFTGATE LATCH POSITION SWITCH

LIFTGATE AUTO CLOSURE SYSTEM

0914-5b

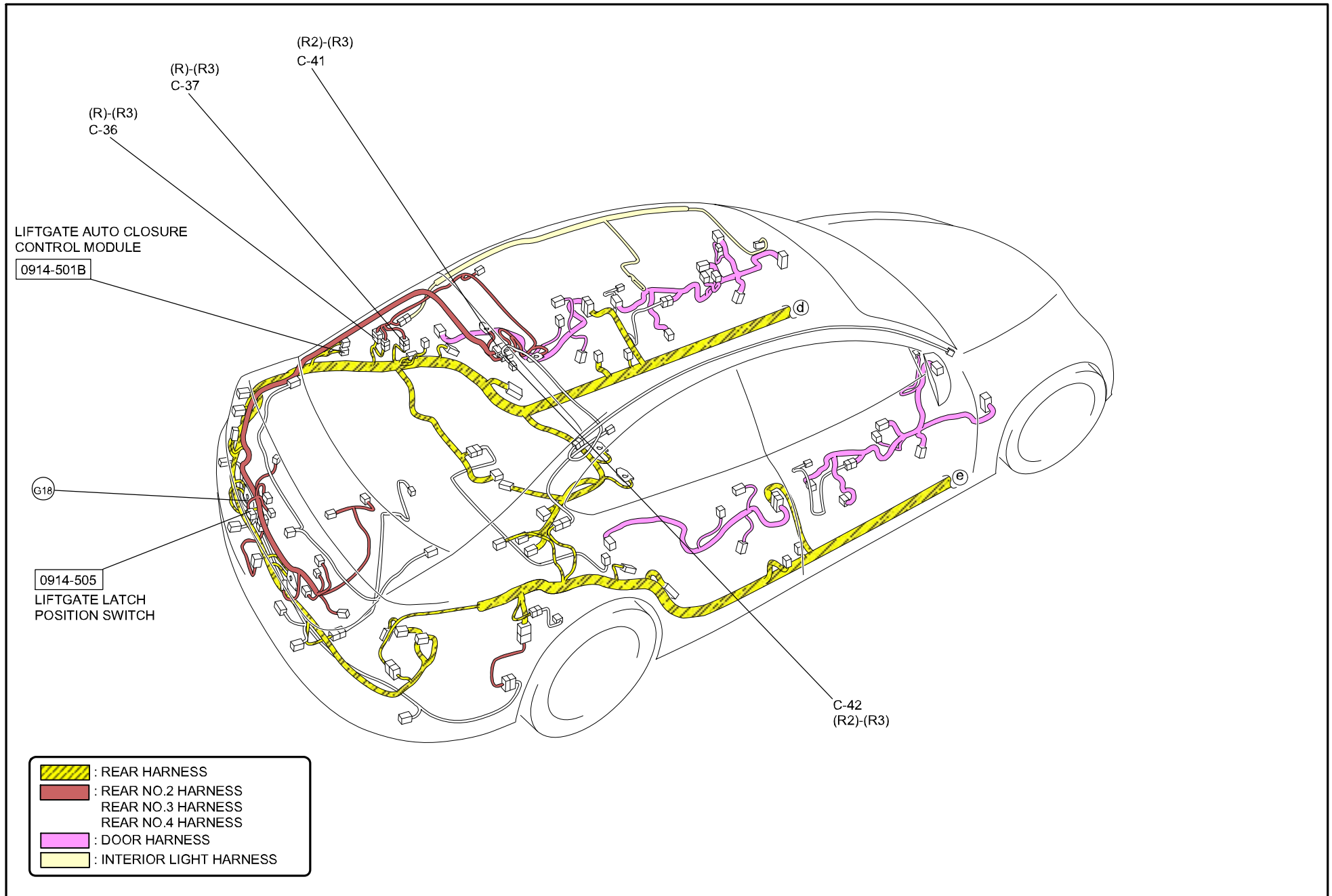

C-36
REAR HARNESS-REAR NO.3 HARNESS

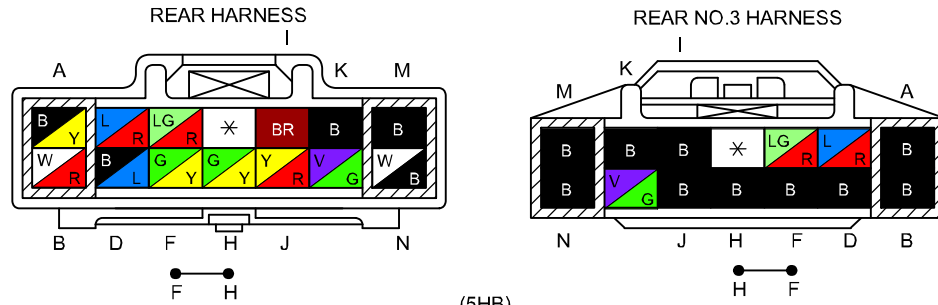

C-37
REAR HARNESS-REAR NO.3 HARNESS

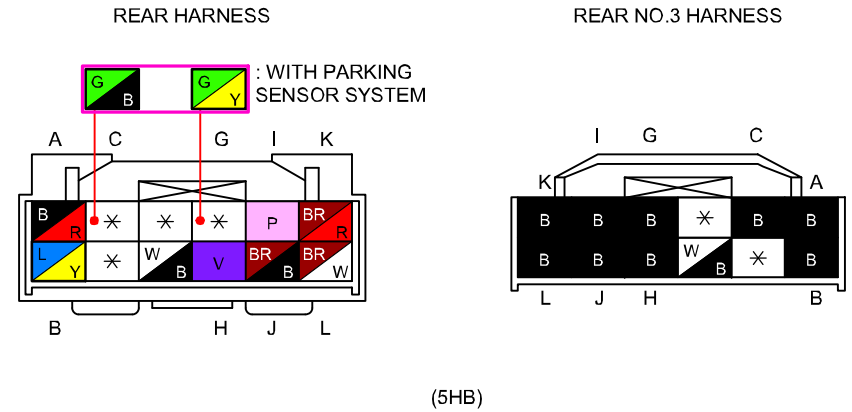

C-41
REAR NO.2 HARNESS-REAR NO.3 HARNESS

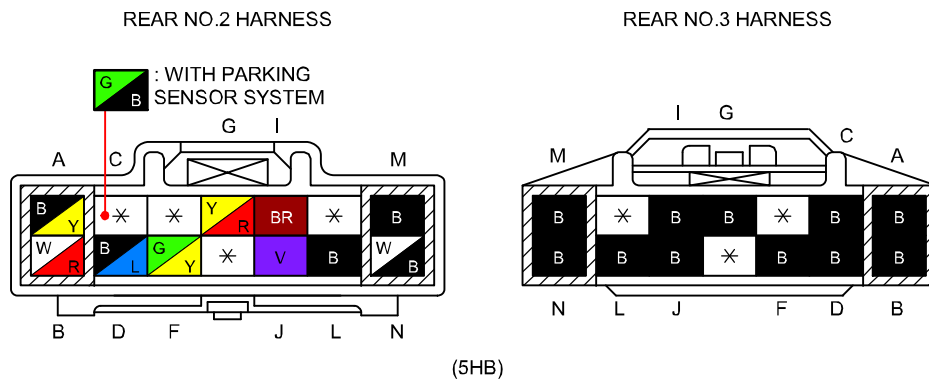

C-42
REAR NO.2 HARNESS-REAR NO.3 HARNESS

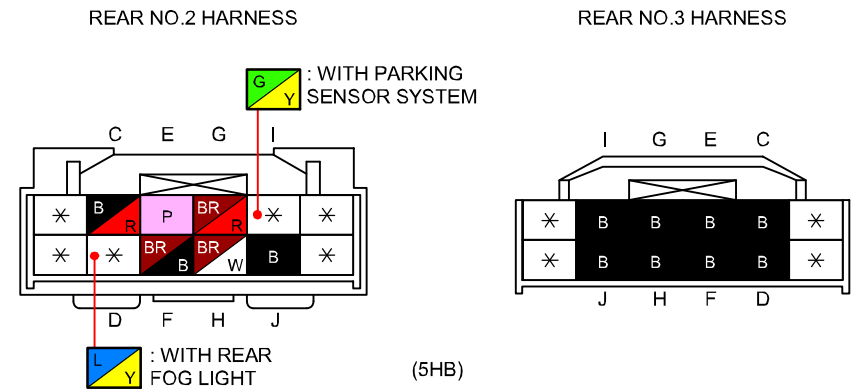

POWER DOOR LOCK SYSTEM (WITHOUT DOUBLE LOCKING SYSTEM)

0914-6a

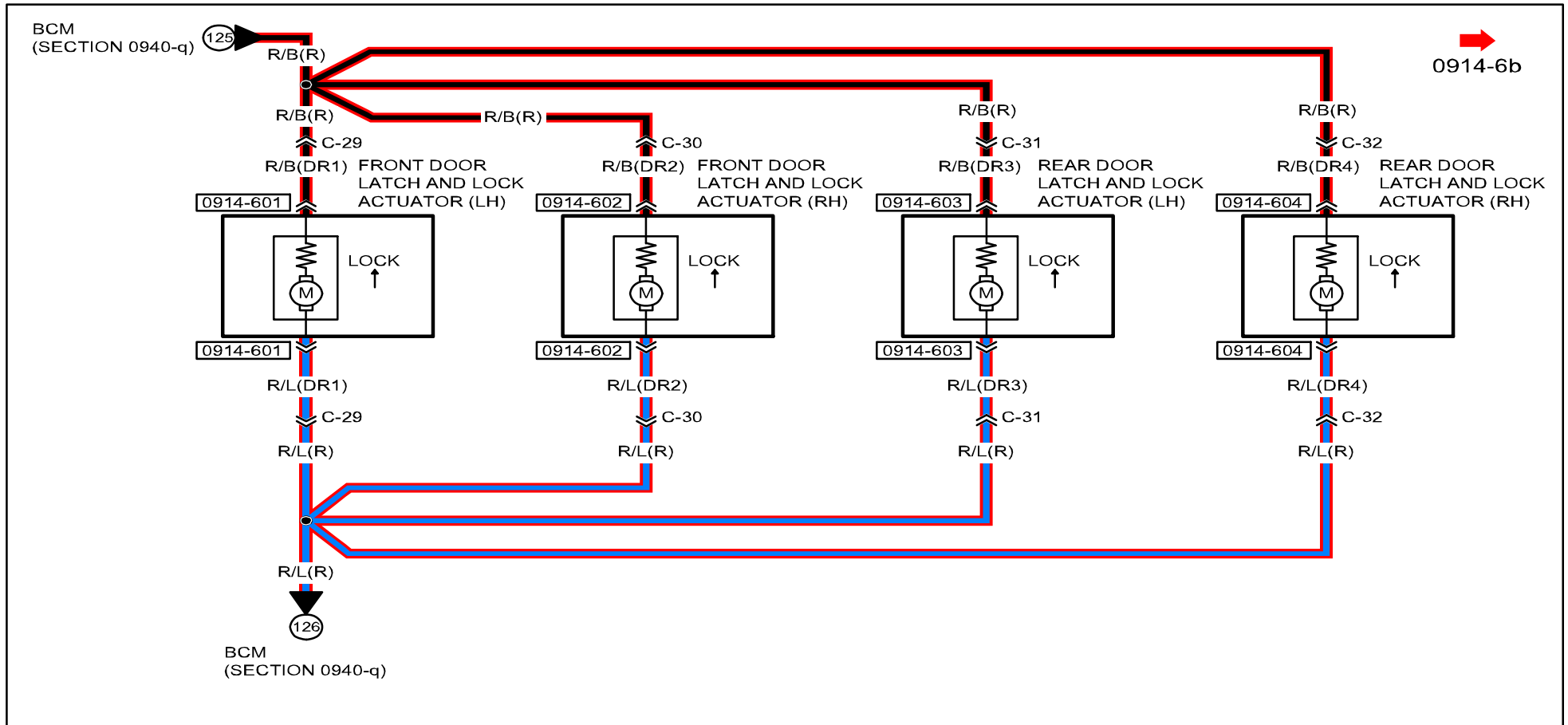







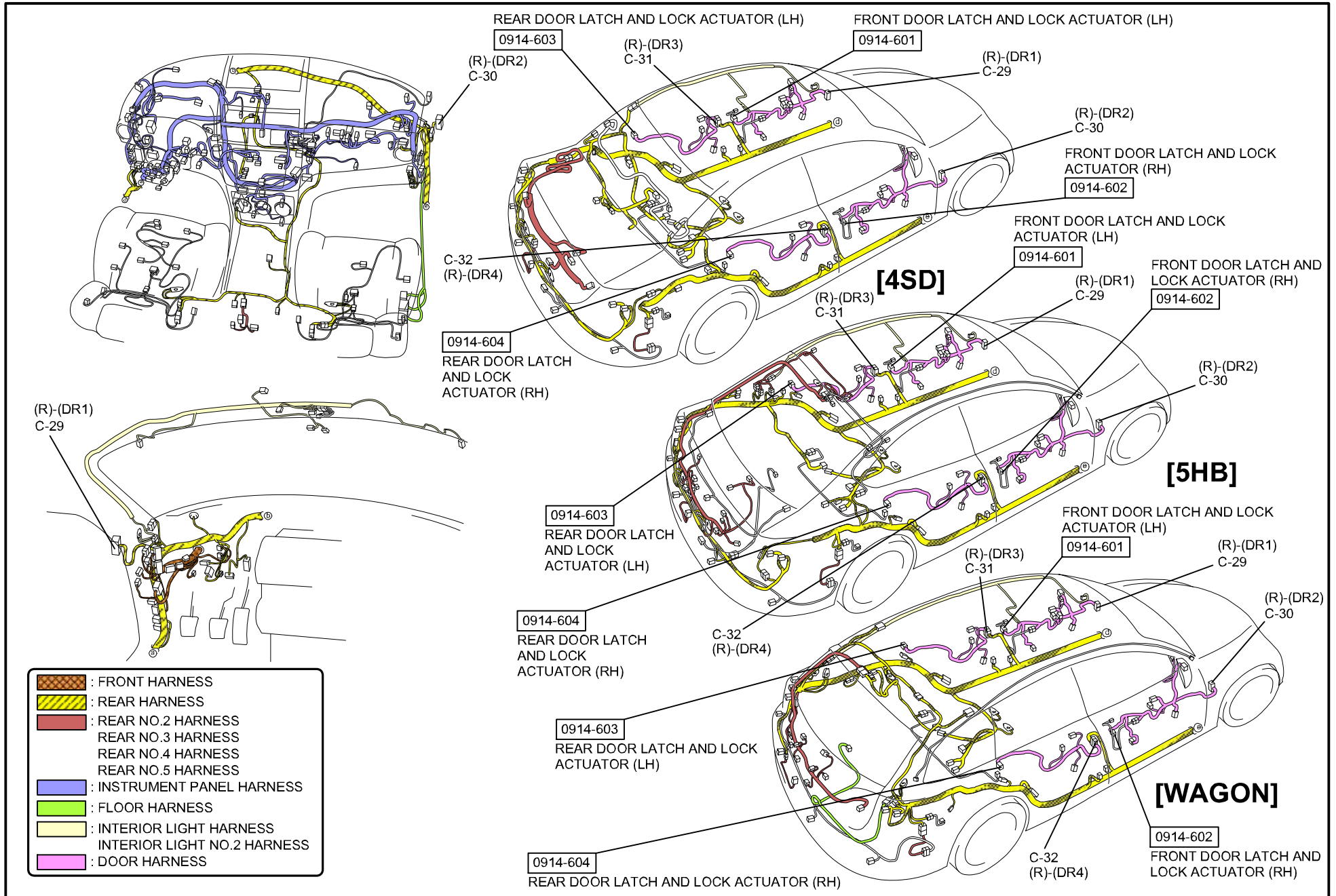



<p>0914-601 FRONT DOOR LATCH AND LOCK ACTUATOR (LH)</p>	<p>0914-602 FRONT DOOR LATCH AND LOCK ACTUATOR (RH)</p>	<p>0914-603 REAR DOOR LATCH AND LOCK ACTUATOR (LH)</p>
<p>0914-604 REAR DOOR LATCH AND LOCK ACTUATOR (RH)</p>		

POWER DOOR LOCK SYSTEM (WITHOUT DOUBLE LOCKING SYSTEM)

0914-6a



-  : FRONT HARNESS
-  : REAR HARNESS
-  : REAR NO.2 HARNESS
-  : REAR NO.3 HARNESS
-  : REAR NO.4 HARNESS
-  : REAR NO.5 HARNESS
-  : INSTRUMENT PANEL HARNESS
-  : FLOOR HARNESS
-  : INTERIOR LIGHT HARNESS
-  : INTERIOR LIGHT NO.2 HARNESS
-  : DOOR HARNESS

POWER DOOR LOCK SYSTEM (WITHOUT DOUBLE LOCKING SYSTEM)

0914-6a

C-29

REAR HARNESS-DOOR NO.1 HARNESS

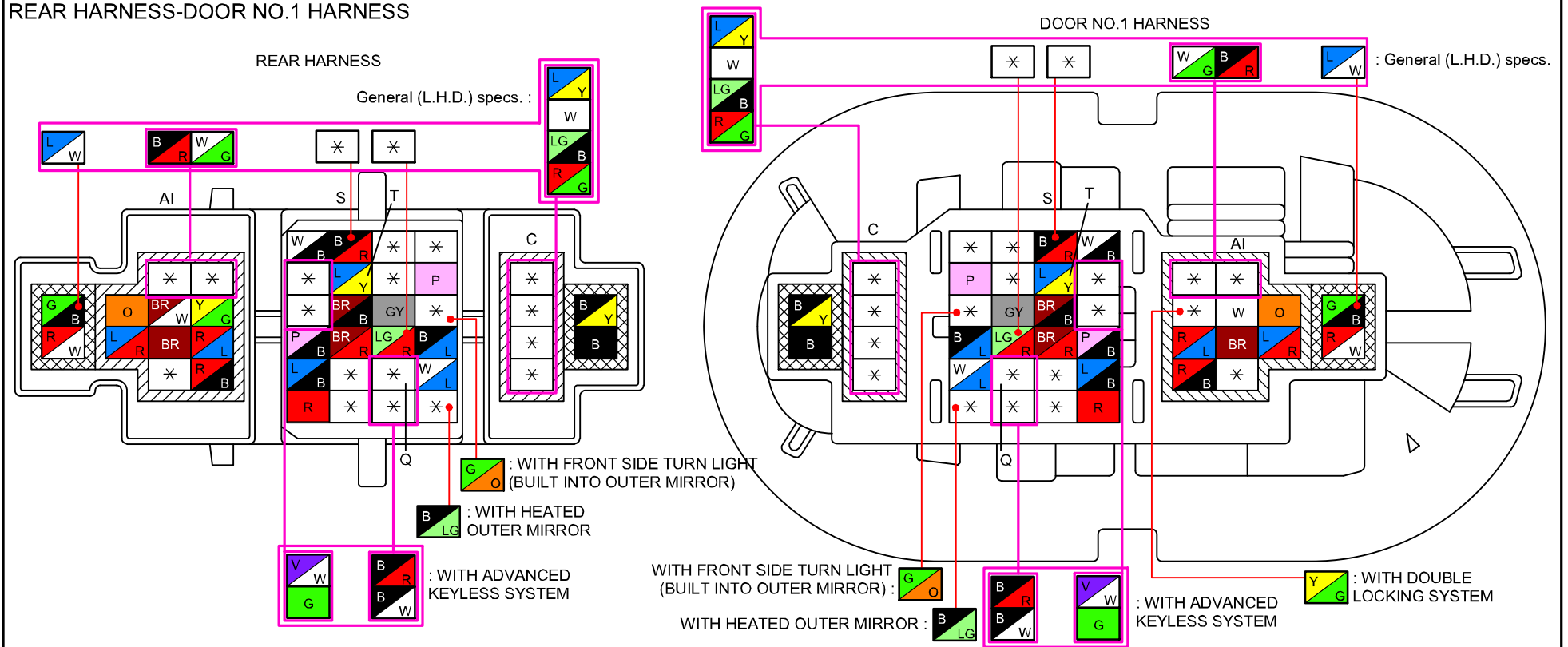

POWER DOOR LOCK SYSTEM (WITHOUT DOUBLE LOCKING SYSTEM)

0914-6a

C-30

REAR HARNESS-DOOR NO.2 HARNESS

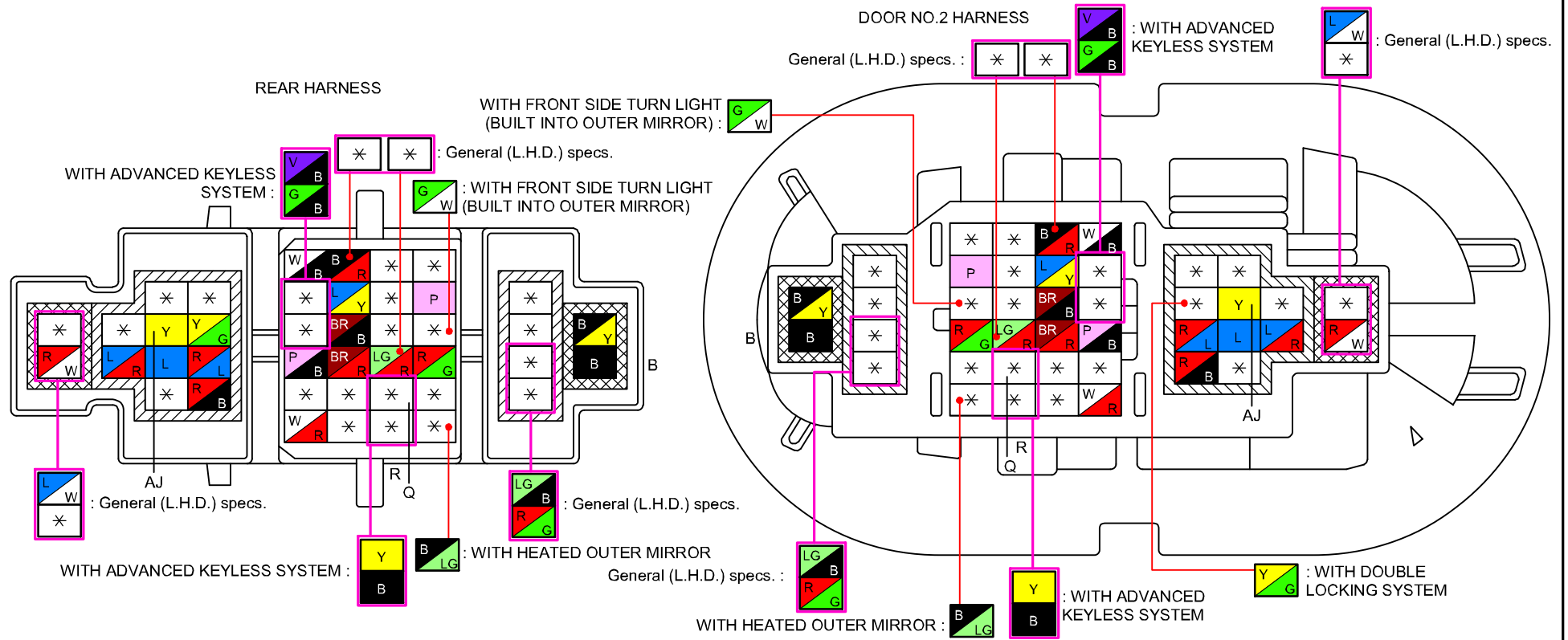

POWER DOOR LOCK SYSTEM (WITHOUT DOUBLE LOCKING SYSTEM)

0914-6a

C-31
REAR HARNESS-DOOR NO.3 HARNESS
REAR HARNESS

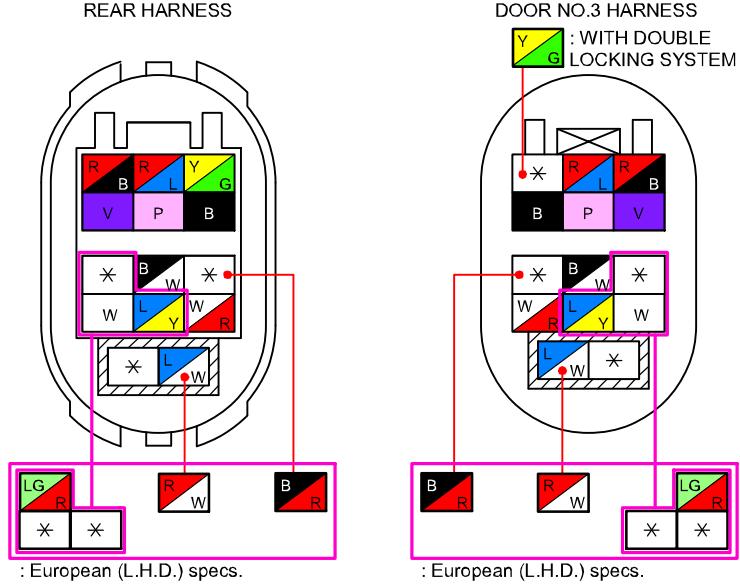

C-32
REAR HARNESS-DOOR NO.4 HARNESS
REAR HARNESS

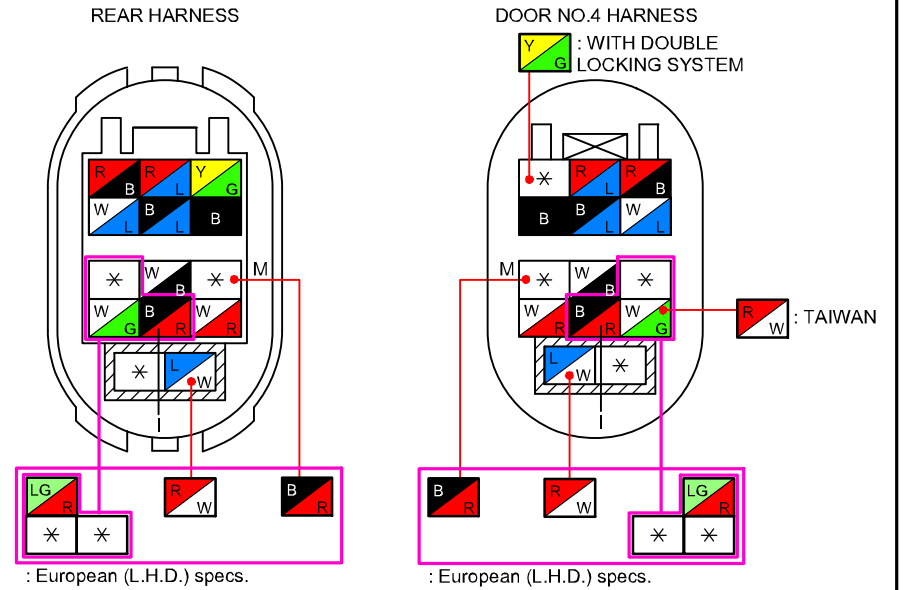

POWER DOOR LOCK SYSTEM (WITHOUT DOUBLE LOCKING SYSTEM)

0914-6b

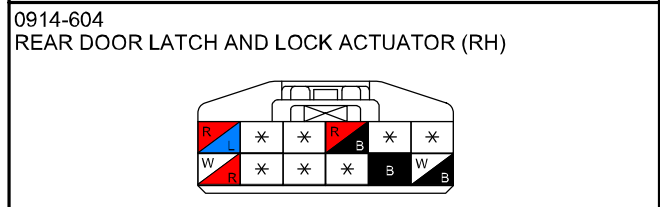
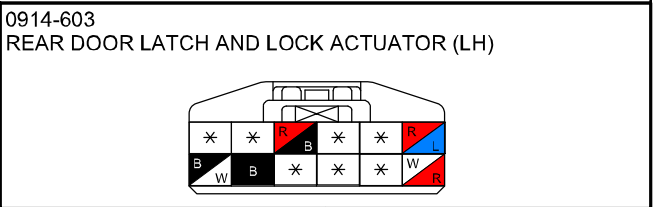
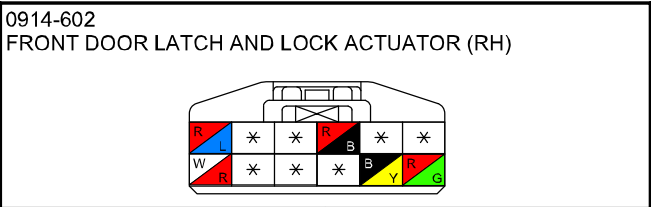
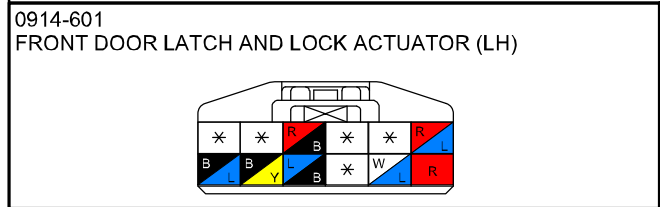
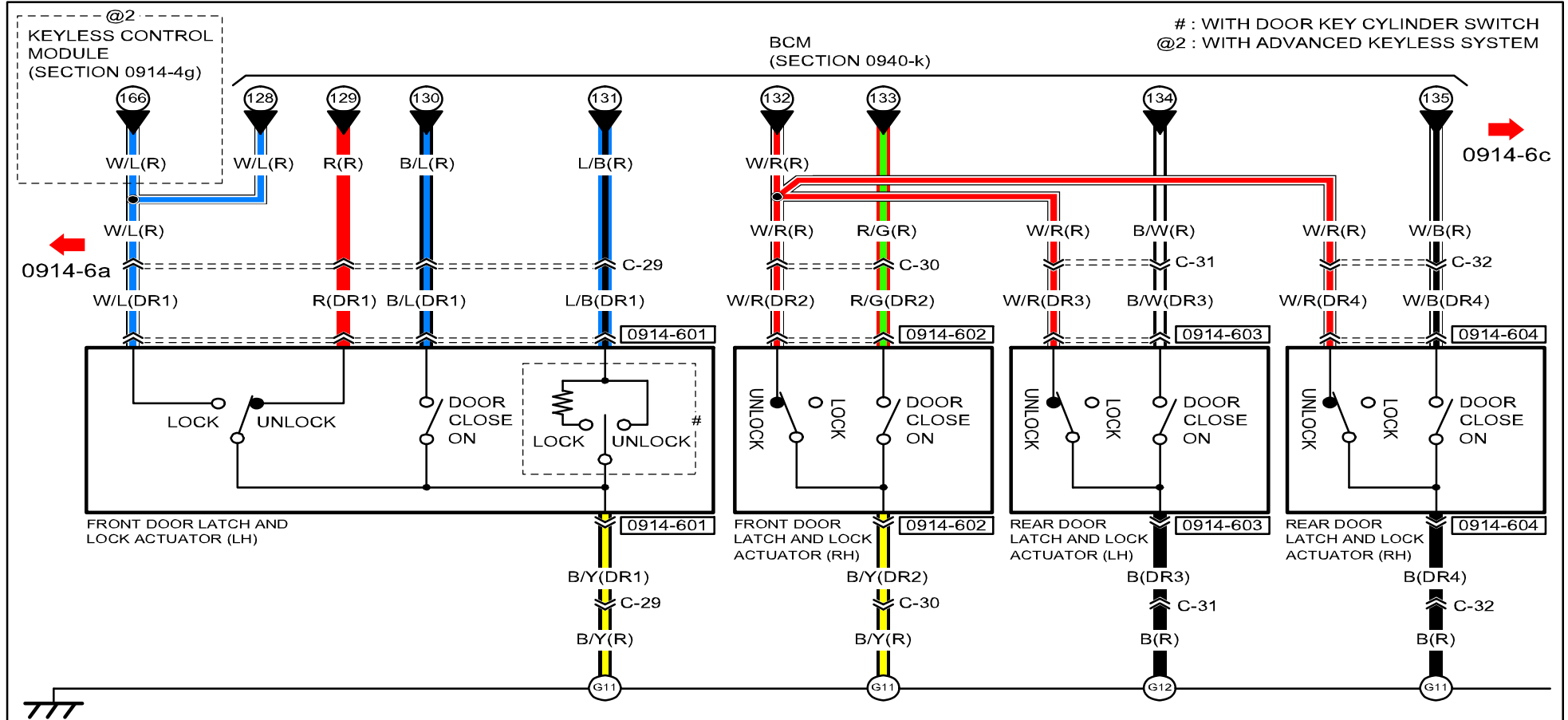

POWER DOOR LOCK SYSTEM (WITHOUT DOUBLE LOCKING SYSTEM)

0914-6b

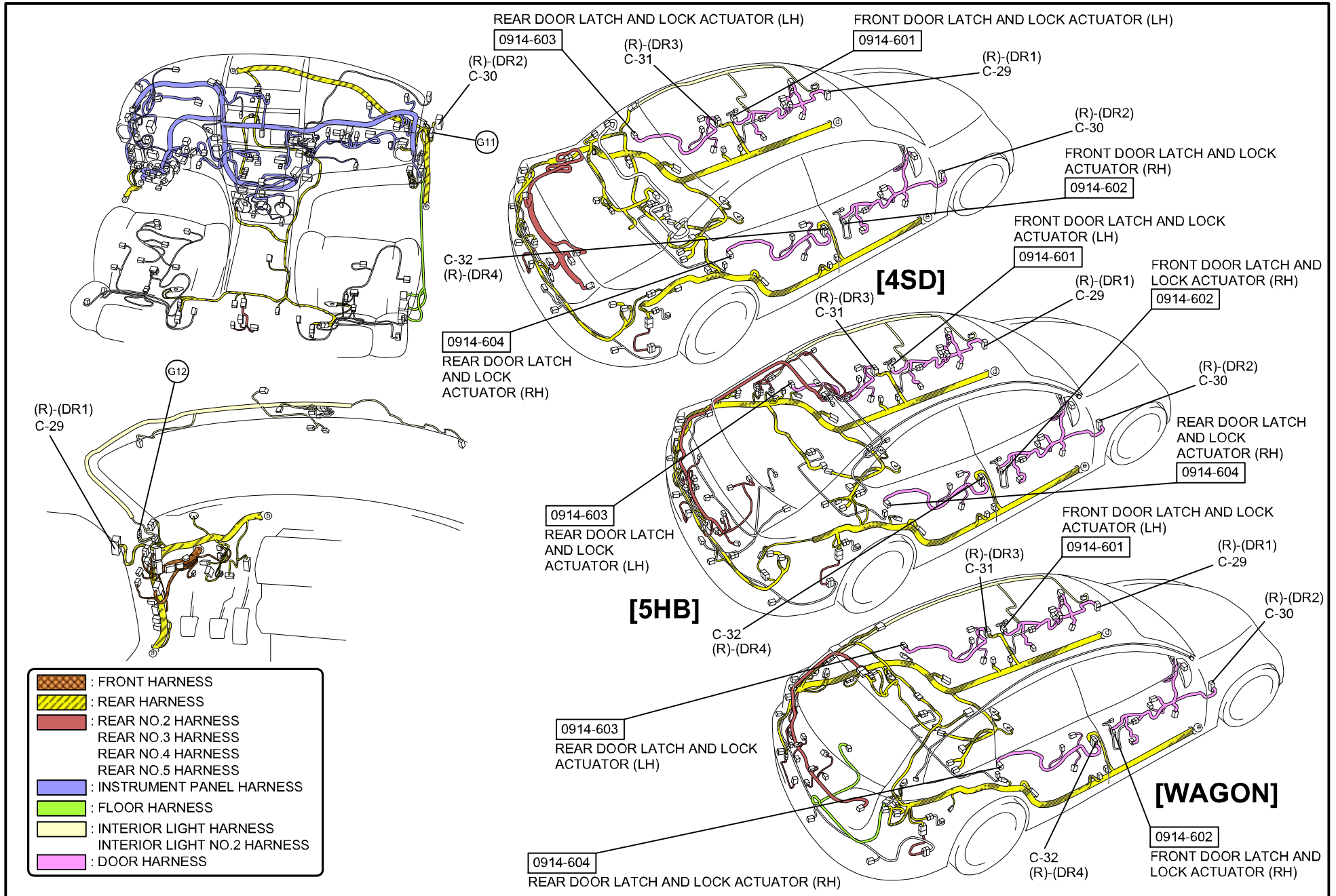

POWER DOOR LOCK SYSTEM (WITHOUT DOUBLE LOCKING SYSTEM)

0914-6b

C-29

REAR HARNESS-DOOR NO.1 HARNESS

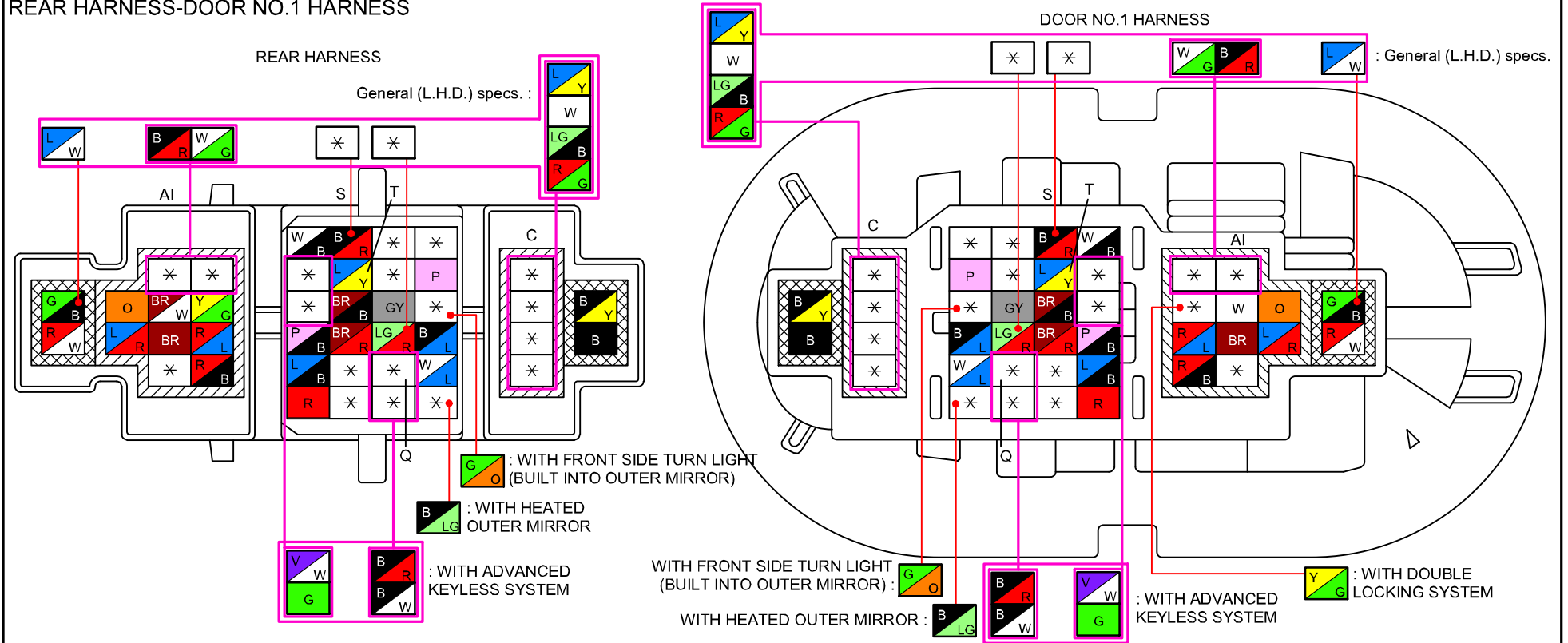

POWER DOOR LOCK SYSTEM (WITHOUT DOUBLE LOCKING SYSTEM)

0914-6b

C-30

REAR HARNESS-DOOR NO.2 HARNESS

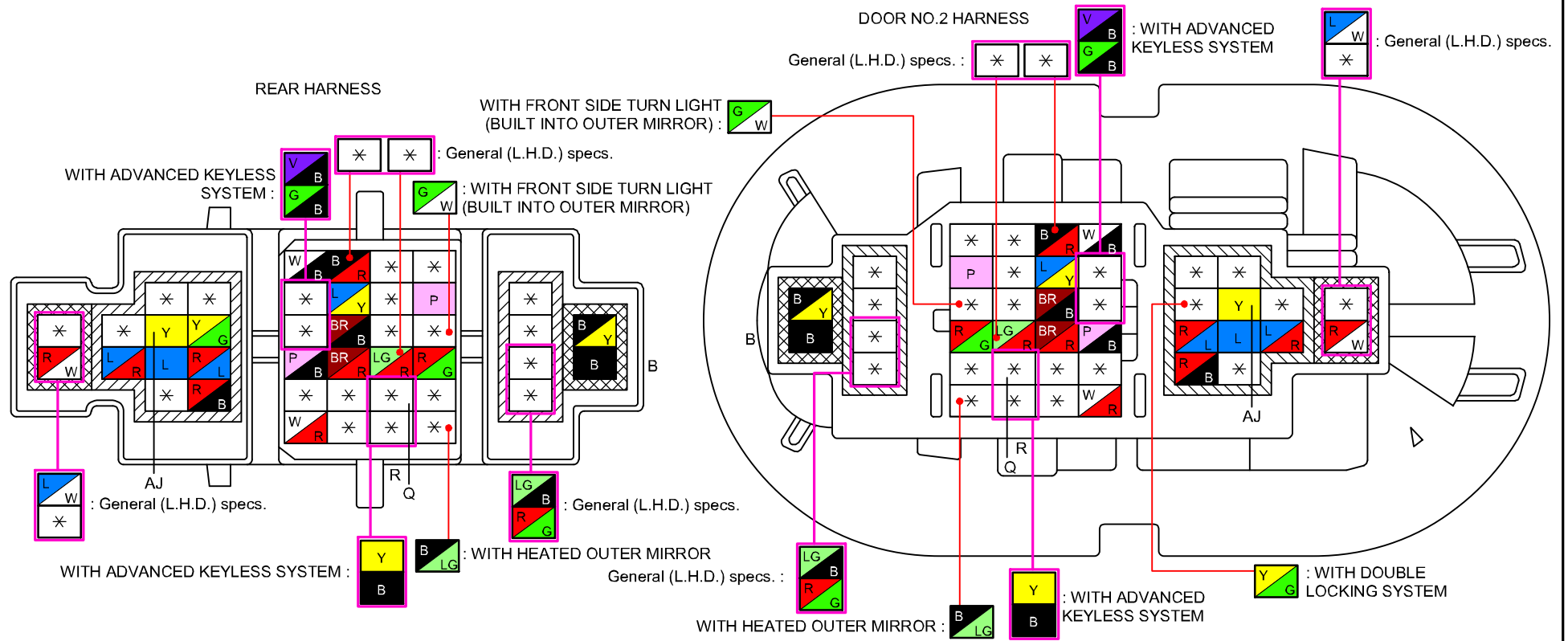

POWER DOOR LOCK SYSTEM (WITHOUT DOUBLE LOCKING SYSTEM)

0914-6b

C-31
REAR HARNESS-DOOR NO.3 HARNESS
REAR HARNESS

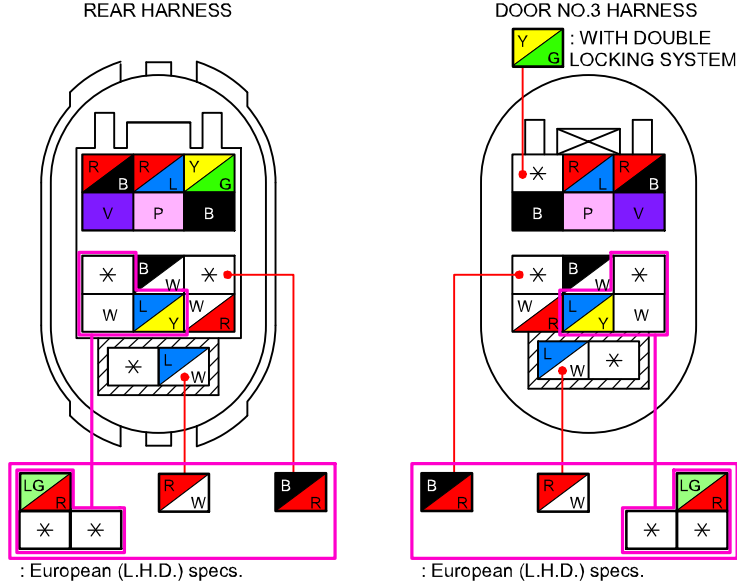

C-32
REAR HARNESS-DOOR NO.4 HARNESS
REAR HARNESS

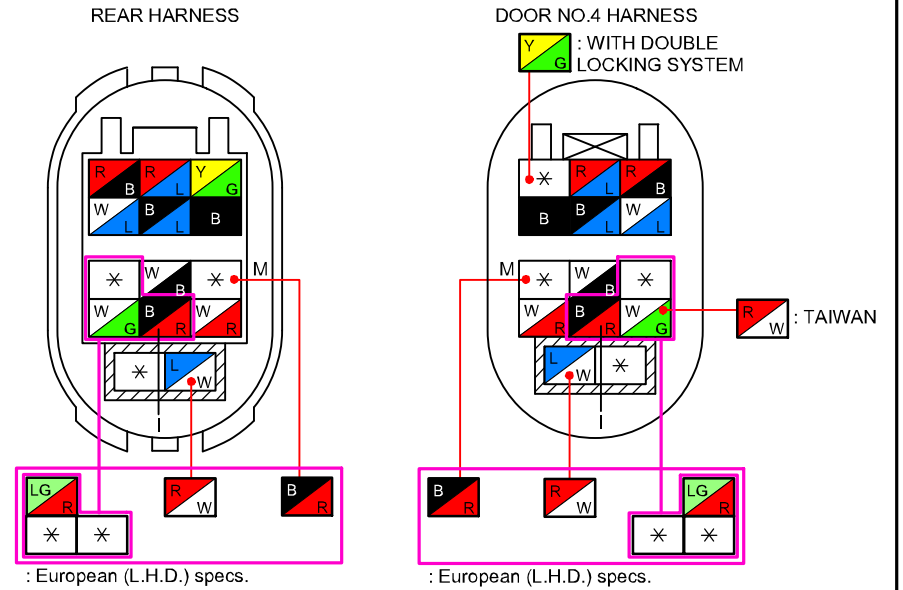

POWER DOOR LOCK SYSTEM (WITHOUT DOUBLE LOCKING SYSTEM)

0914-6c

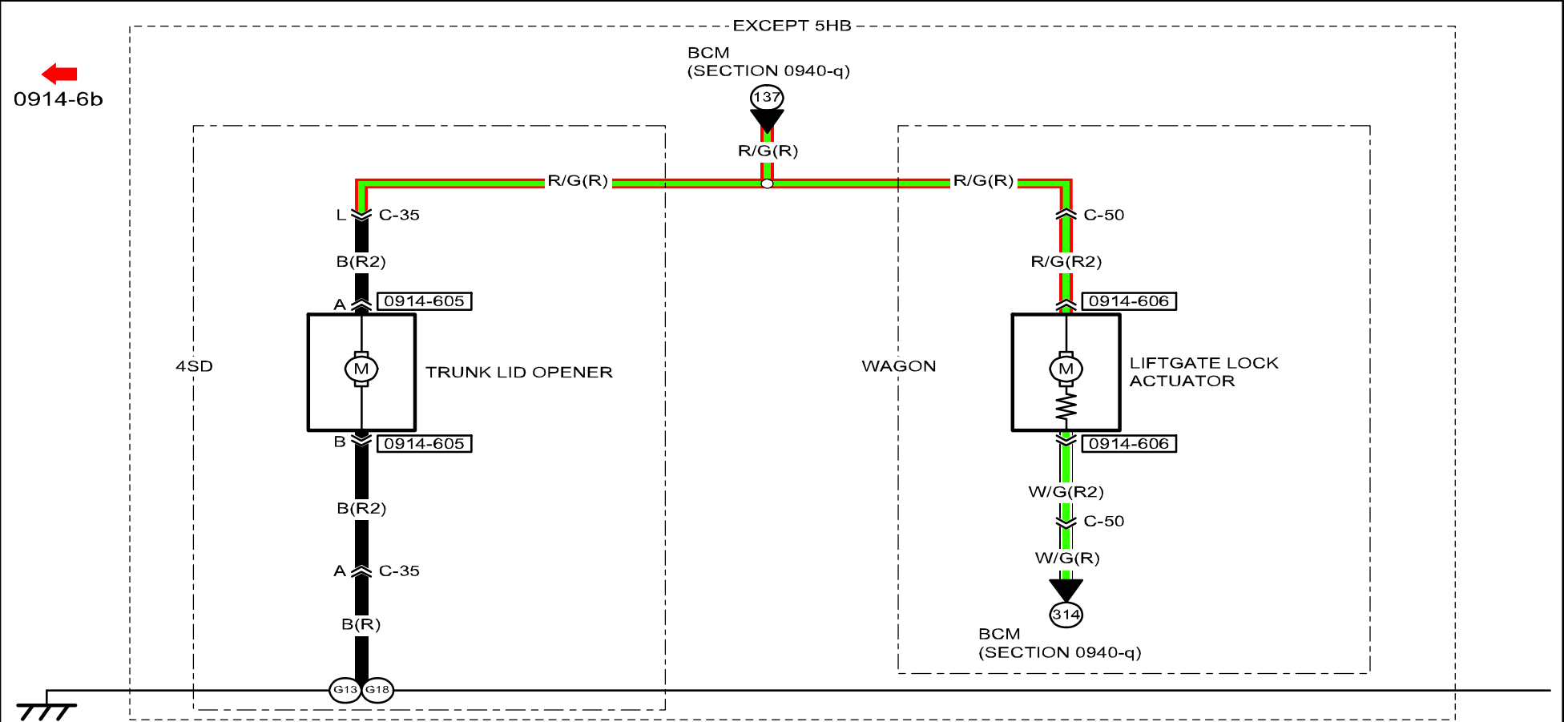

0914-605
TRUNK LID OPENER /
TRUNK COMPARTMENT LIGHT SWITCH

0914-606
LIFTGATE LOCK ACTUATOR /
CARGO COMPARTMENT LIGHT SWITCH

--	--	--	--	--	--

POWER DOOR LOCK SYSTEM (WITHOUT DOUBLE LOCKING SYSTEM)

0914-6c

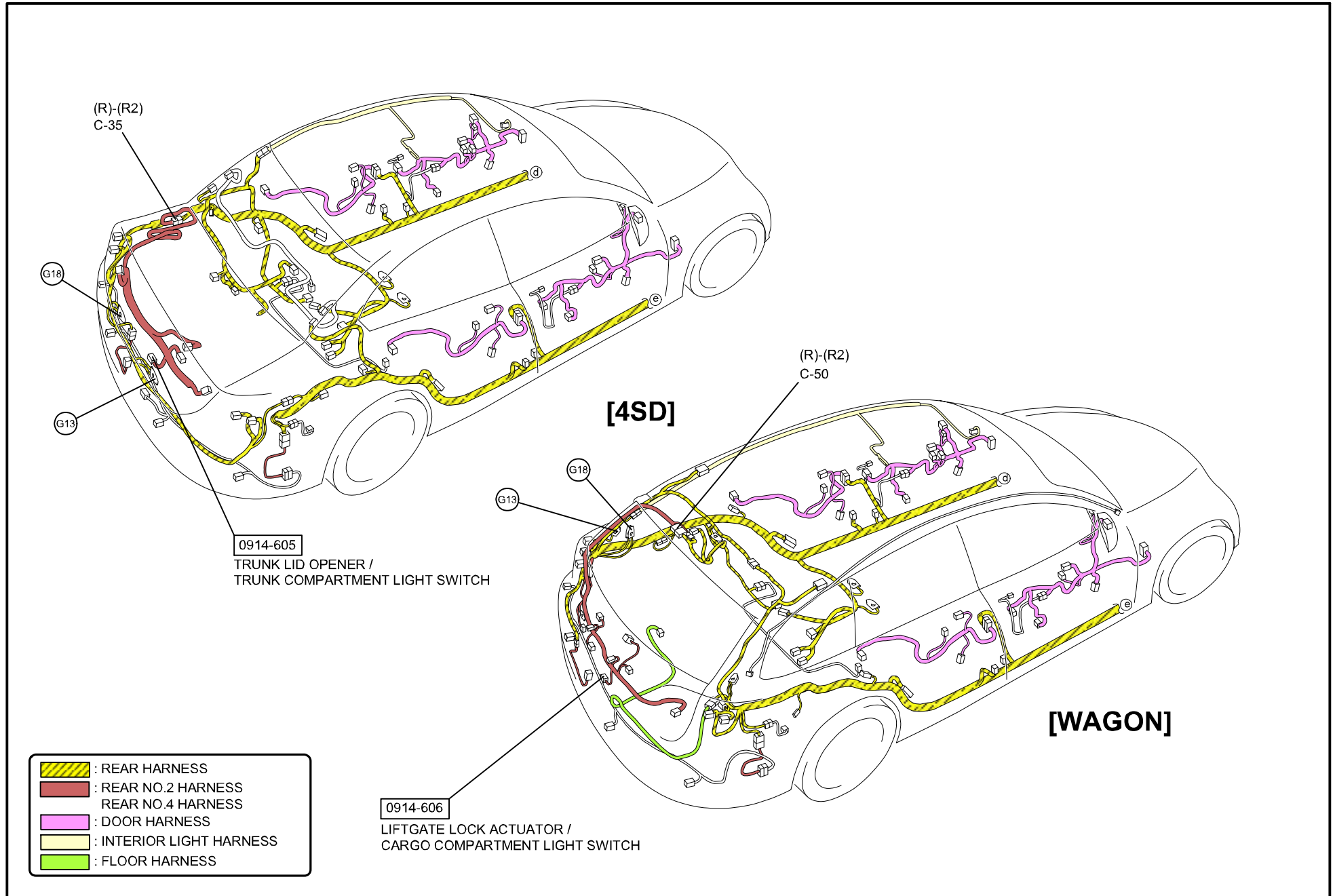



POWER DOOR LOCK SYSTEM (WITHOUT DOUBLE LOCKING SYSTEM)

0914-6c

C-35
REAR HARNESS-REAR NO.2 HARNESS

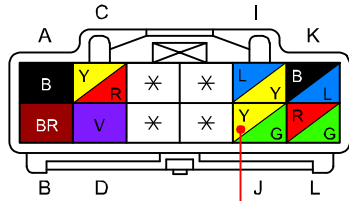
REAR HARNESS



European (L.H.D.) specs. : 

(4SD)

REAR NO.2 HARNESS

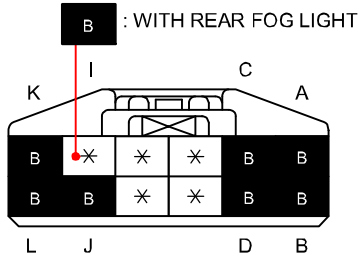

 : WITH REAR FOG LIGHT

C-50
REAR HARNESS-REAR NO.2 HARNESS

REAR HARNESS

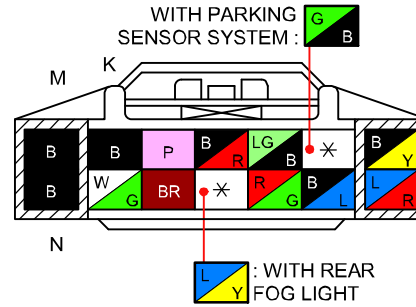

WITH PARKING SENSOR SYSTEM : 

 : WITH REAR FOG LIGHT

REAR NO.2 HARNESS

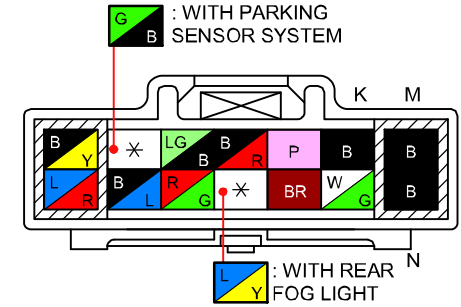

 : WITH PARKING SENSOR SYSTEM

 : WITH REAR FOG LIGHT

(WAGON)

&5 : MZR-CD (RF Turbo)

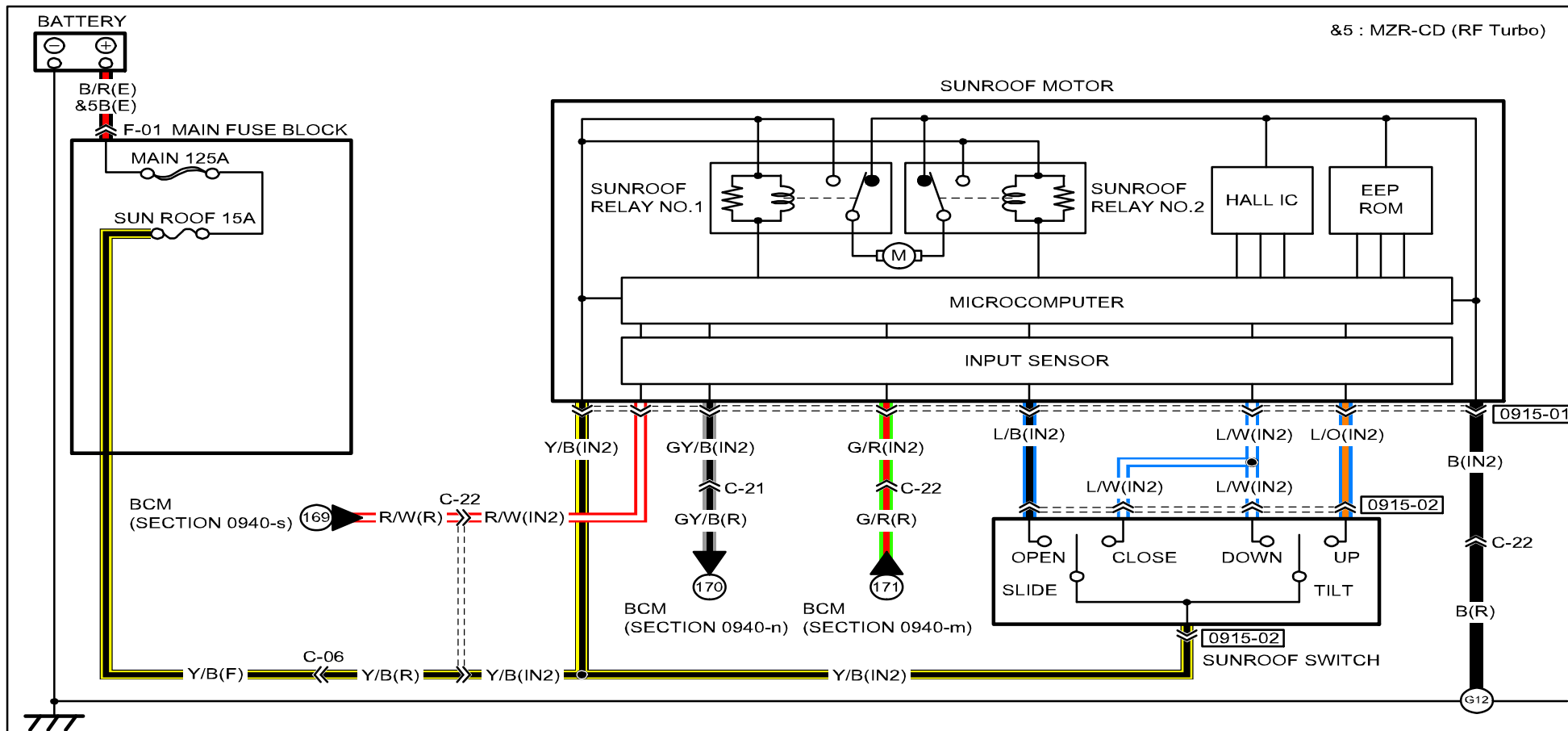

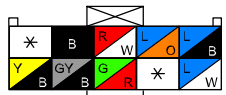
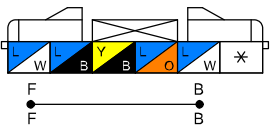
<p>0915-01 SUNROOF MOTOR</p> 	<p>0915-02 SUNROOF SWITCH</p> 			

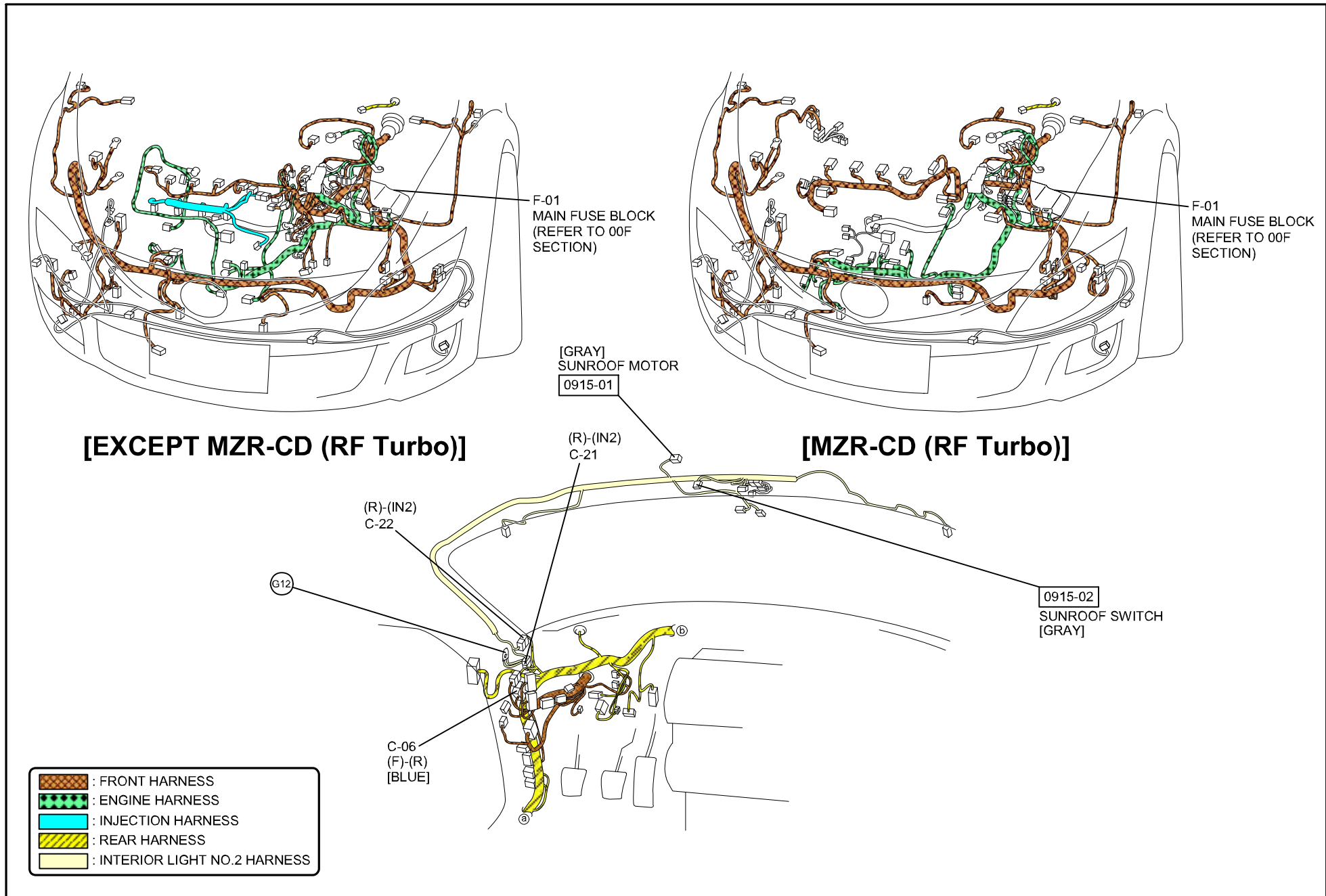

C-22

REAR HARNESS-INTERIOR LIGHT NO.2 HARNESS

REAR HARNESS

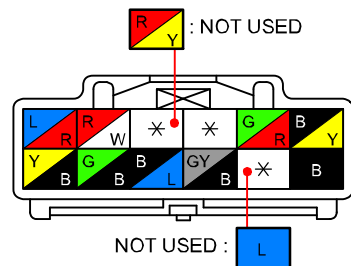

INTERIOR LIGHT NO.2 HARNESS

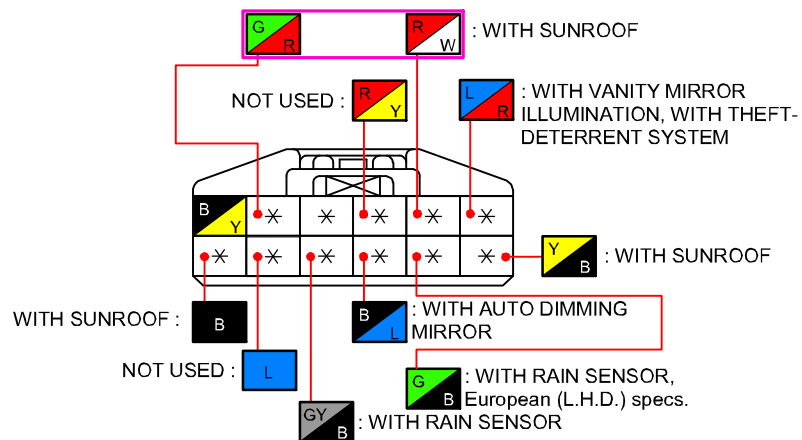

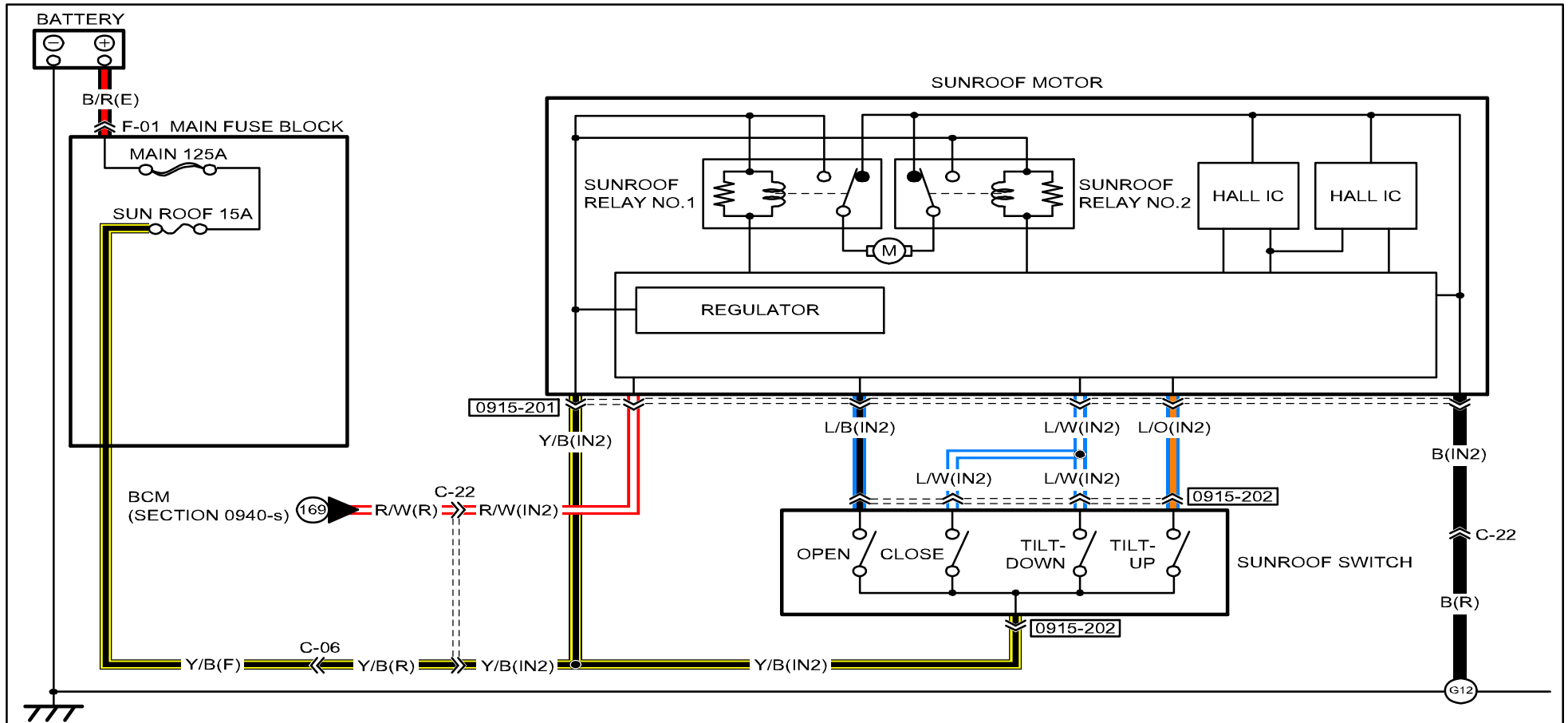

<p>0915-201 SUNROOF MOTOR</p> <p>: NOT USED</p>	<p>0915-202 SUNROOF SWITCH</p> <p>F B F B</p>					

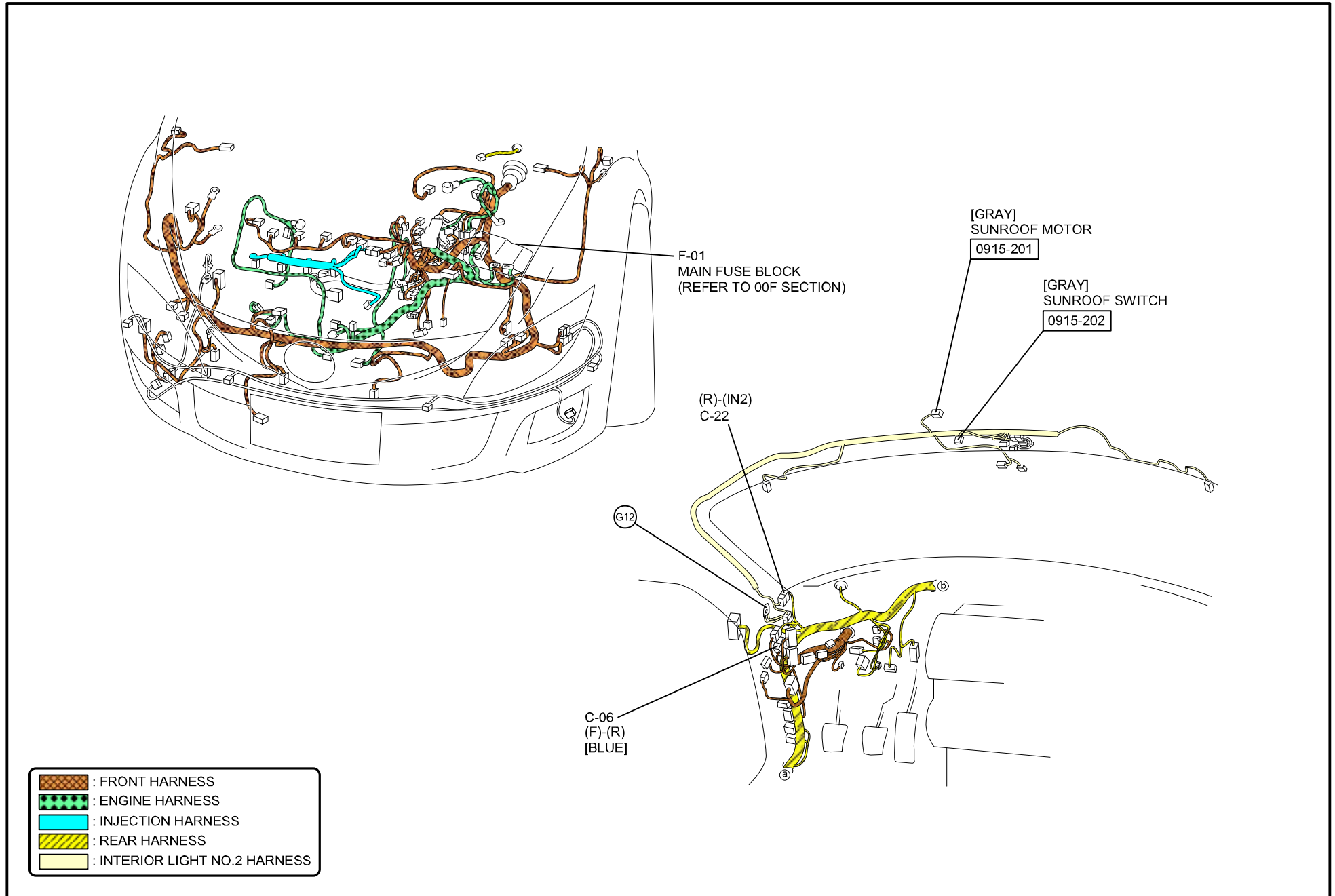

C-06

FRONT HARNESS-REAR HARNESS

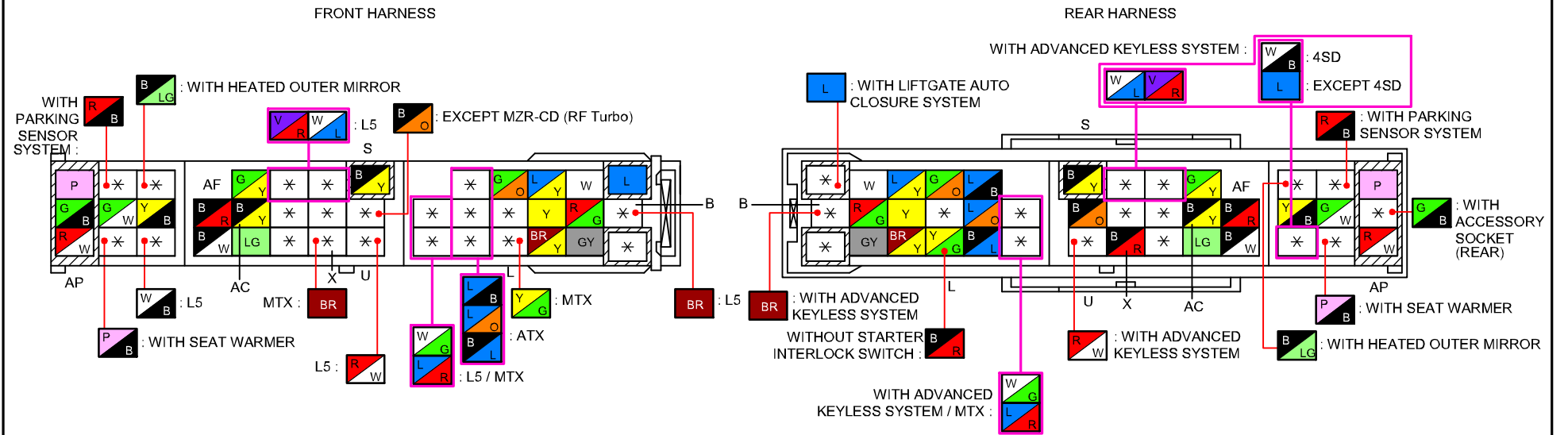

C-22

REAR HARNESS-INTERIOR LIGHT NO.2 HARNESS

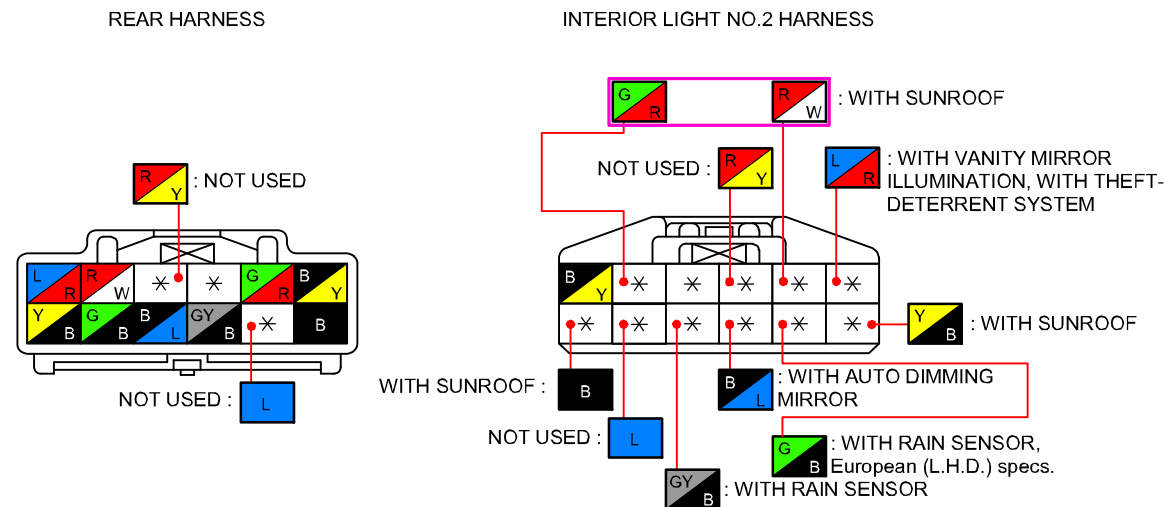

HEADLIGHT

0918-1a

{ } : NAME INDICATED ON FUSE BOX COVER
&5 : MZR-CD (RF Turbo)

0918-1b

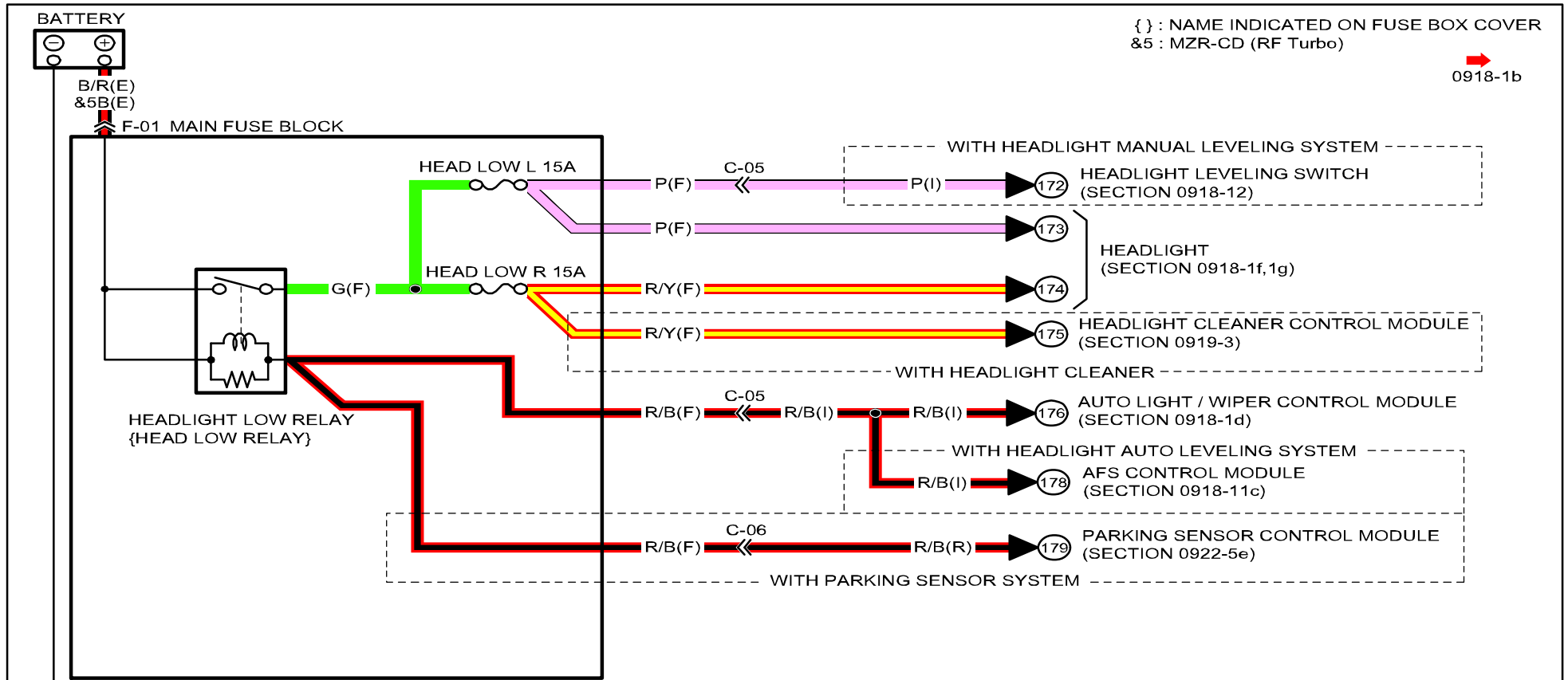

TTT

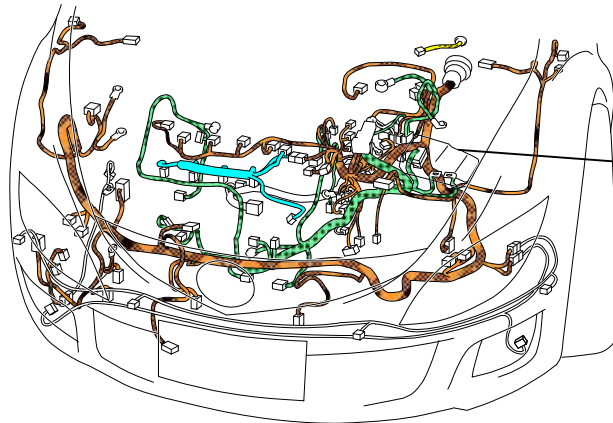

F-01
MAIN FUSE BLOCK
(REFER TO 00F SECTION)

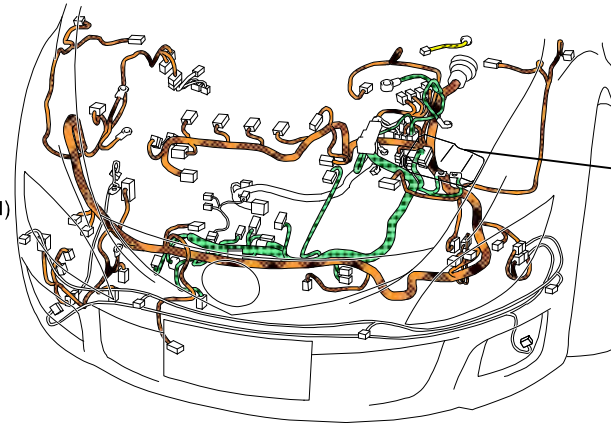

F-01
MAIN FUSE BLOCK
(REFER TO 00F SECTION)

[EXCEPT MZR-CD (RF Turbo)]

[MZR-CD (RF Turbo)]

[BLUE]
(F)-(R)
C-06

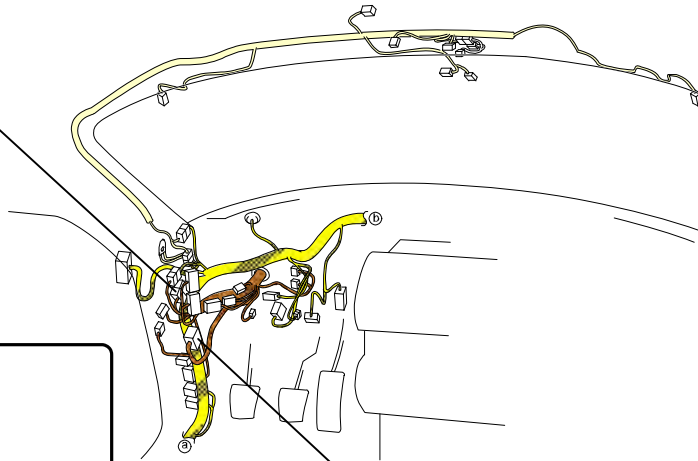

C-05
(F)-(I)
[BLUE]

[BLUE]
(F)-(I)
C-05

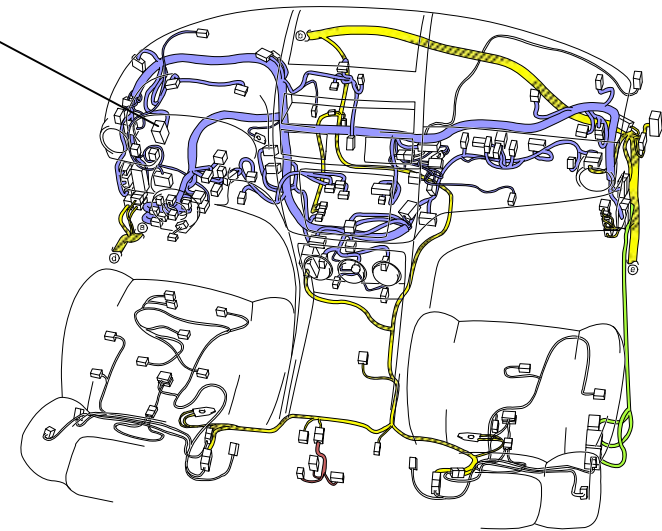

- : FRONT HARNESS
- : ENGINE HARNESS
- : INJECTION HARNESS
- : REAR HARNESS
- : REAR NO.5 HARNESS
- : INSTRUMENT PANEL HARNESS
- : FLOOR HARNESS
- : INTERIOR LIGHT NO.2 HARNESS

C-05
FRONT HARNESS-INSTRUMENT PANEL HARNESS

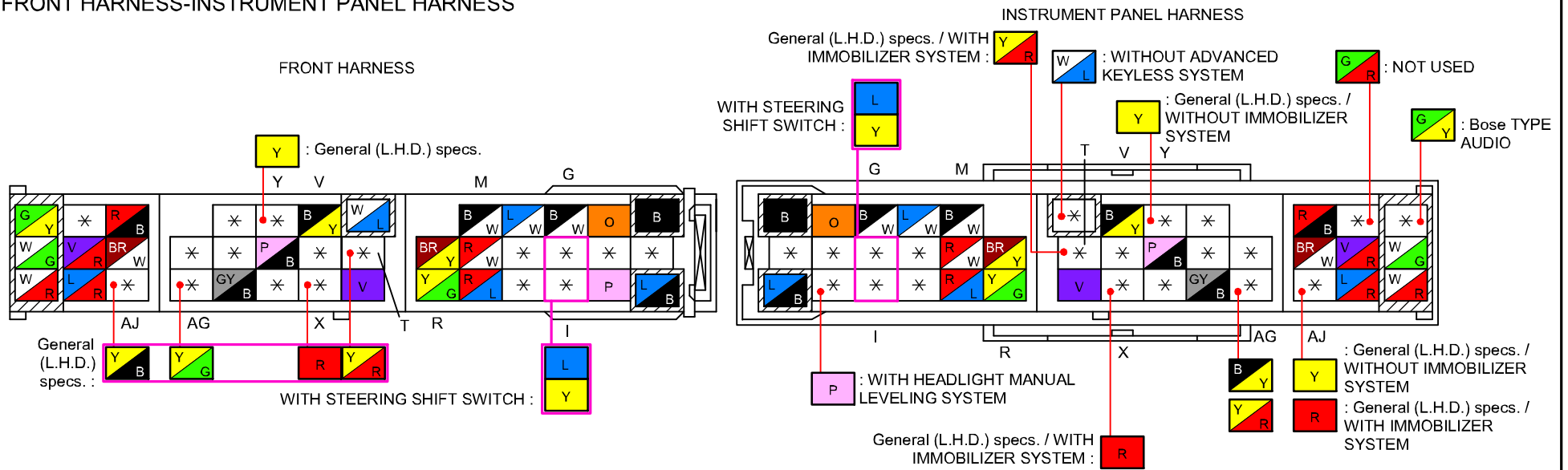

C-06
FRONT HARNESS-REAR HARNESS

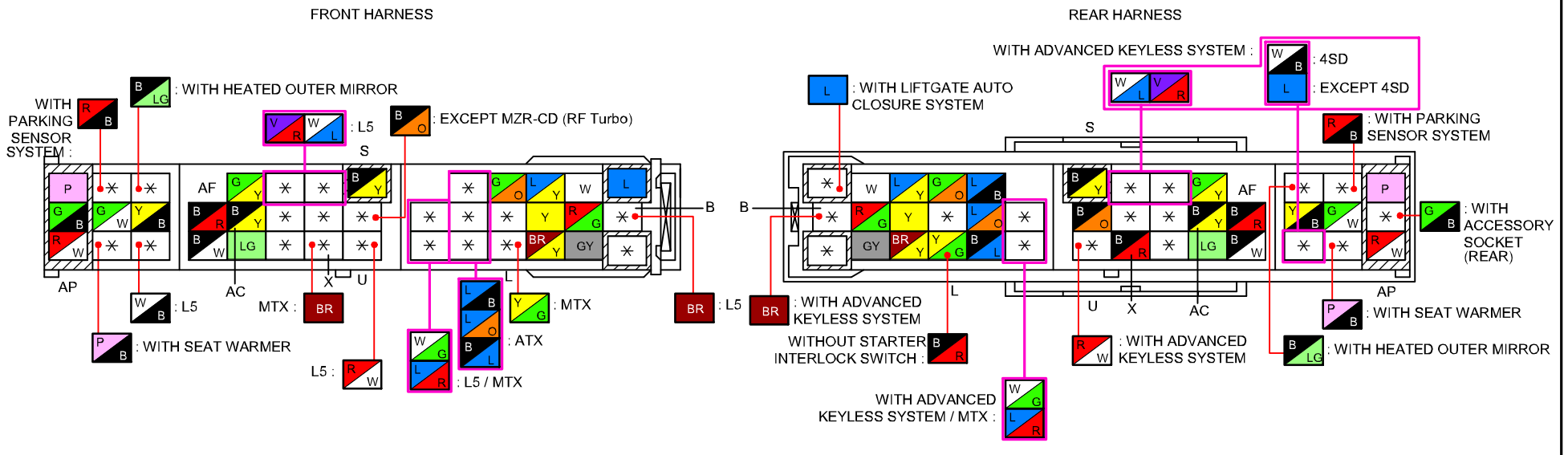

HEADLIGHT

0918-1b

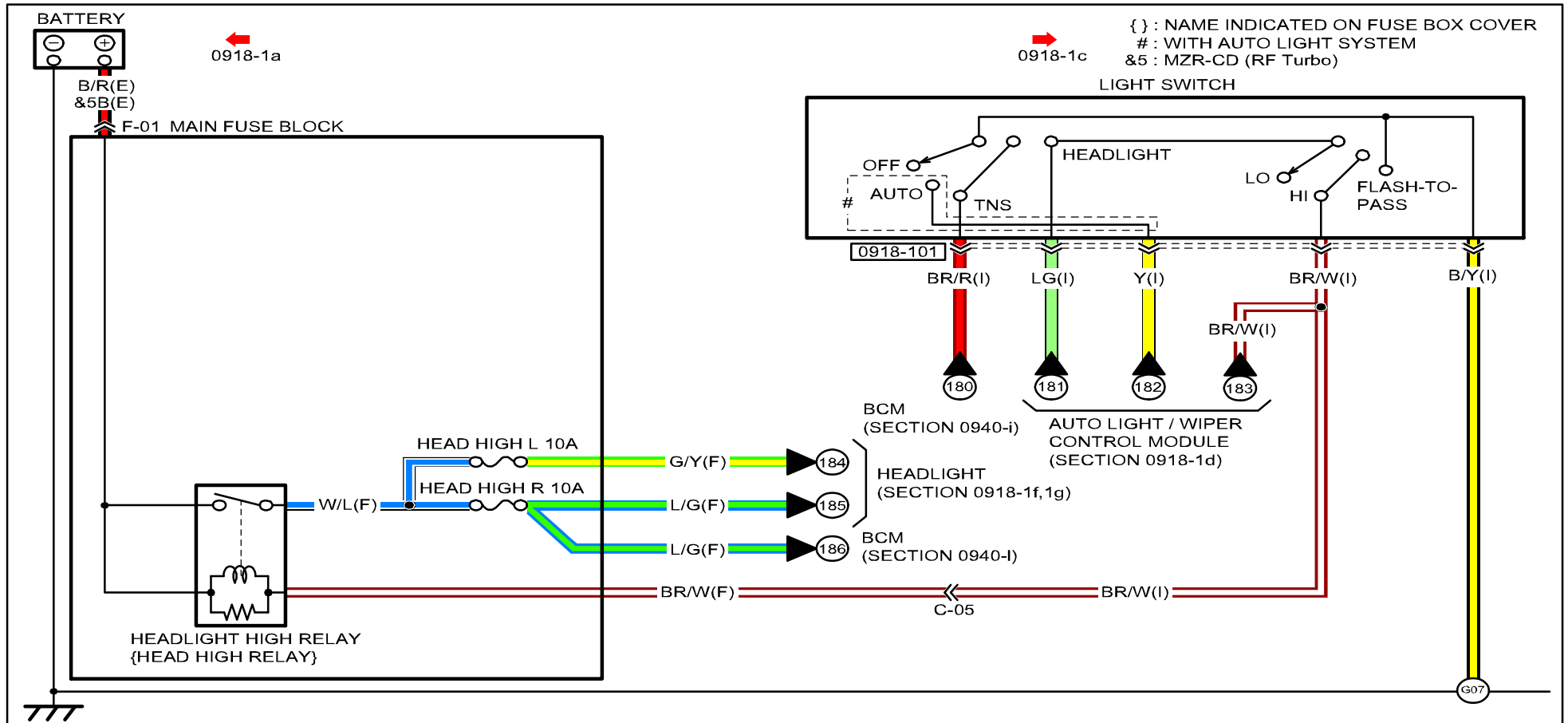

<p>0918-101 LIGHT SWITCH / FOG LIGHT SWITCH / TURN SWITCH</p>					

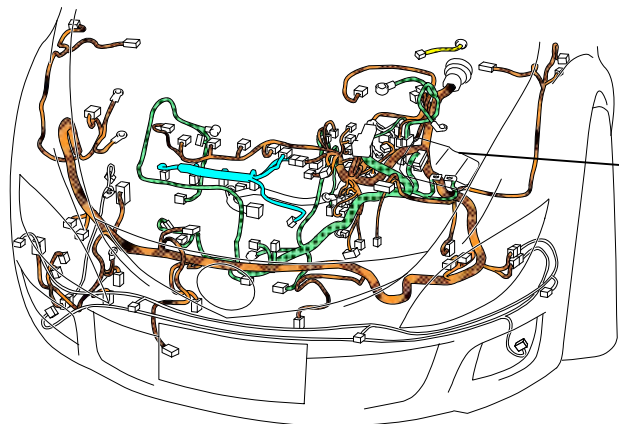

F-01
MAIN FUSE BLOCK
(REFER TO 00F SECTION)

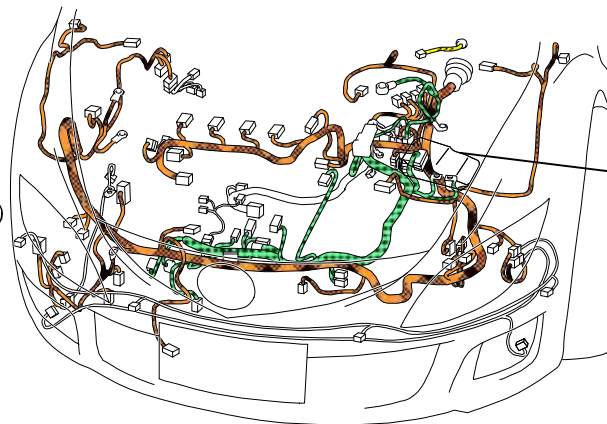

F-01
MAIN FUSE BLOCK
(REFER TO 00F SECTION)

[EXCEPT MZR-CD (RF Turbo)]



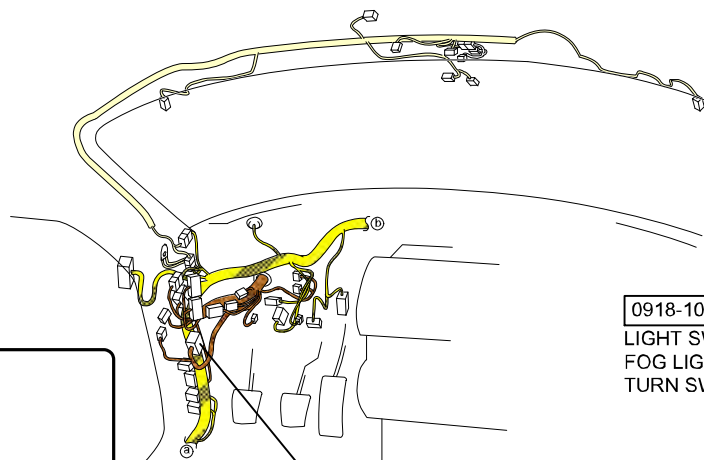



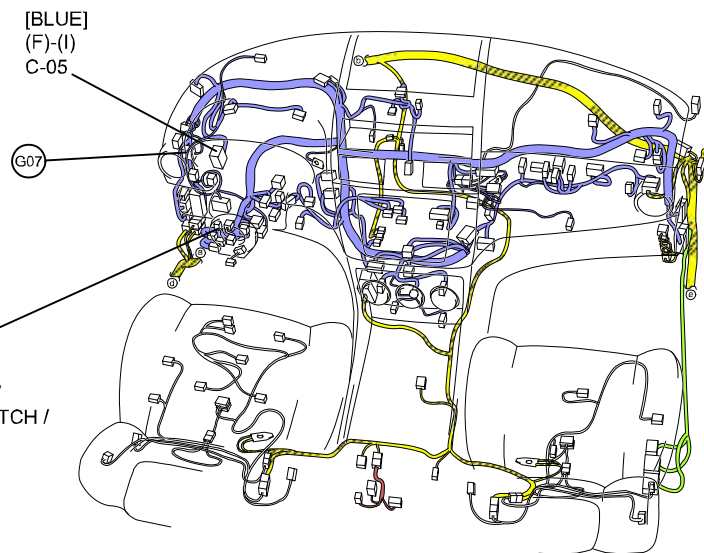

[MZR-CD (RF Turbo)]



C-05
(F)-(I)
[BLUE]



0918-101
LIGHT SWITCH /
FOG LIGHT SWITCH /
TURN SWITCH

-  : FRONT HARNESS
-  : ENGINE HARNESS
-  : INJECTION HARNESS
-  : REAR HARNESS
-  : REAR NO.5 HARNESS
-  : INSTRUMENT PANEL HARNESS
-  : FLOOR HARNESS
-  : INTERIOR LIGHT NO.2 HARNESS

C-05

FRONT HARNESS-INSTRUMENT PANEL HARNESS

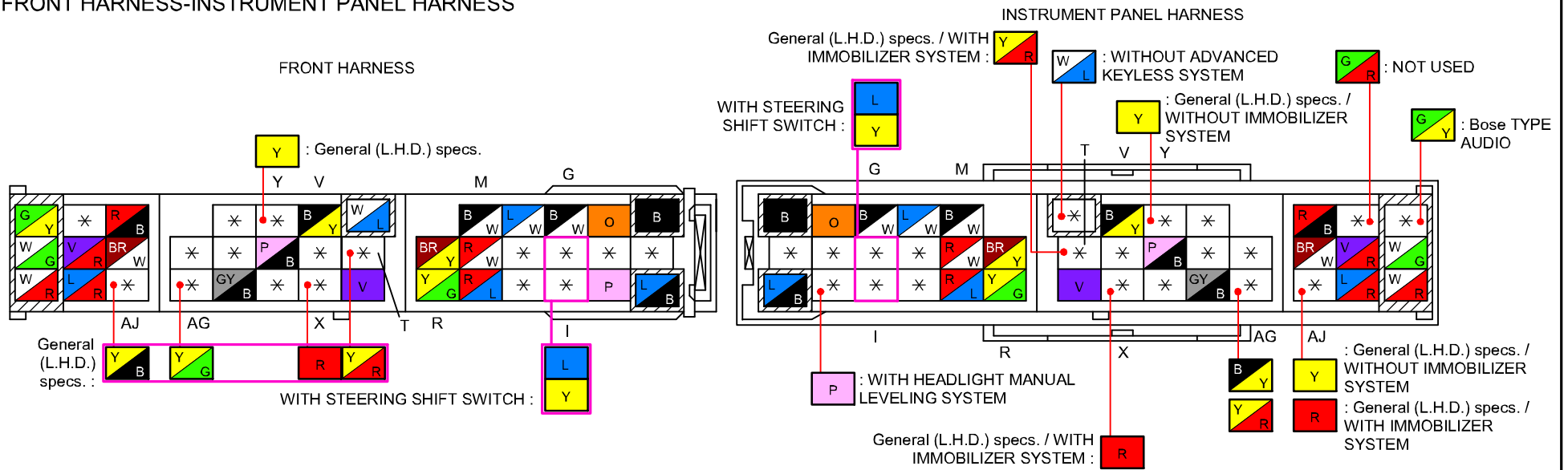

HEADLIGHT



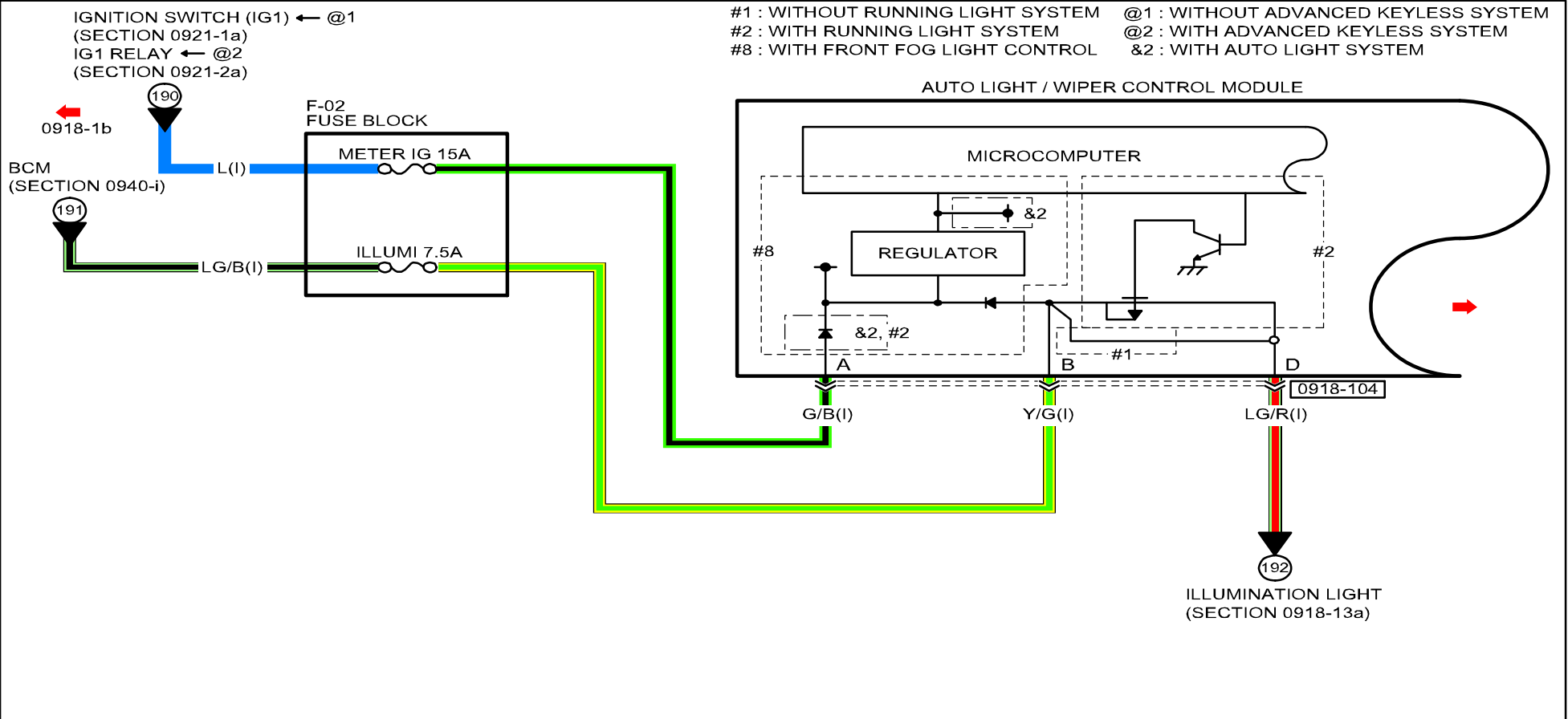

0918-1c



<p>0918-104 AUTO LIGHT / WIPER CONTROL MODULE</p>				

F-02
FUSE BLOCK
(REFER TO 00F SECTION)

0918-104
AUTO LIGHT / WIPER CONTROL MODULE

-  : REAR HARNESS
-  : REAR NO.5 HARNESS
-  : INSTRUMENT PANEL HARNESS
-  : FLOOR HARNESS

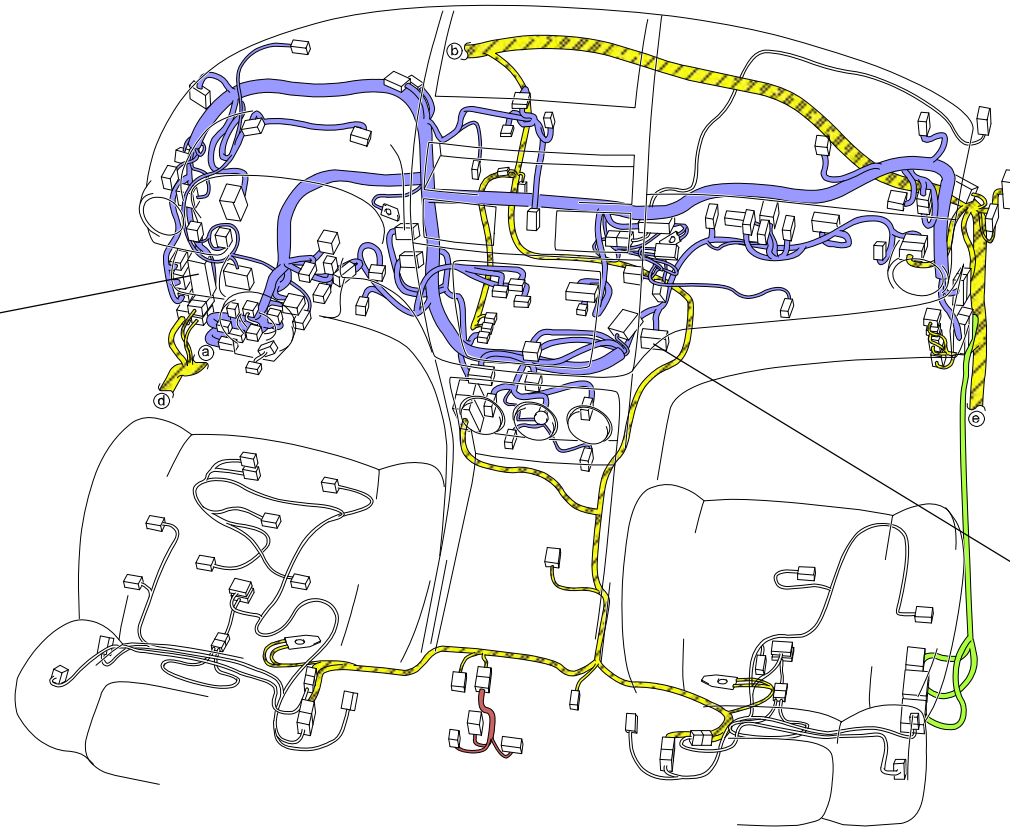

&1 : WITHOUT AUTO LIGHT SYSTEM
 &2 : WITH AUTO LIGHT SYSTEM

#1 : WITHOUT RUNNING LIGHT SYSTEM
 #2 : WITH RUNNING LIGHT SYSTEM

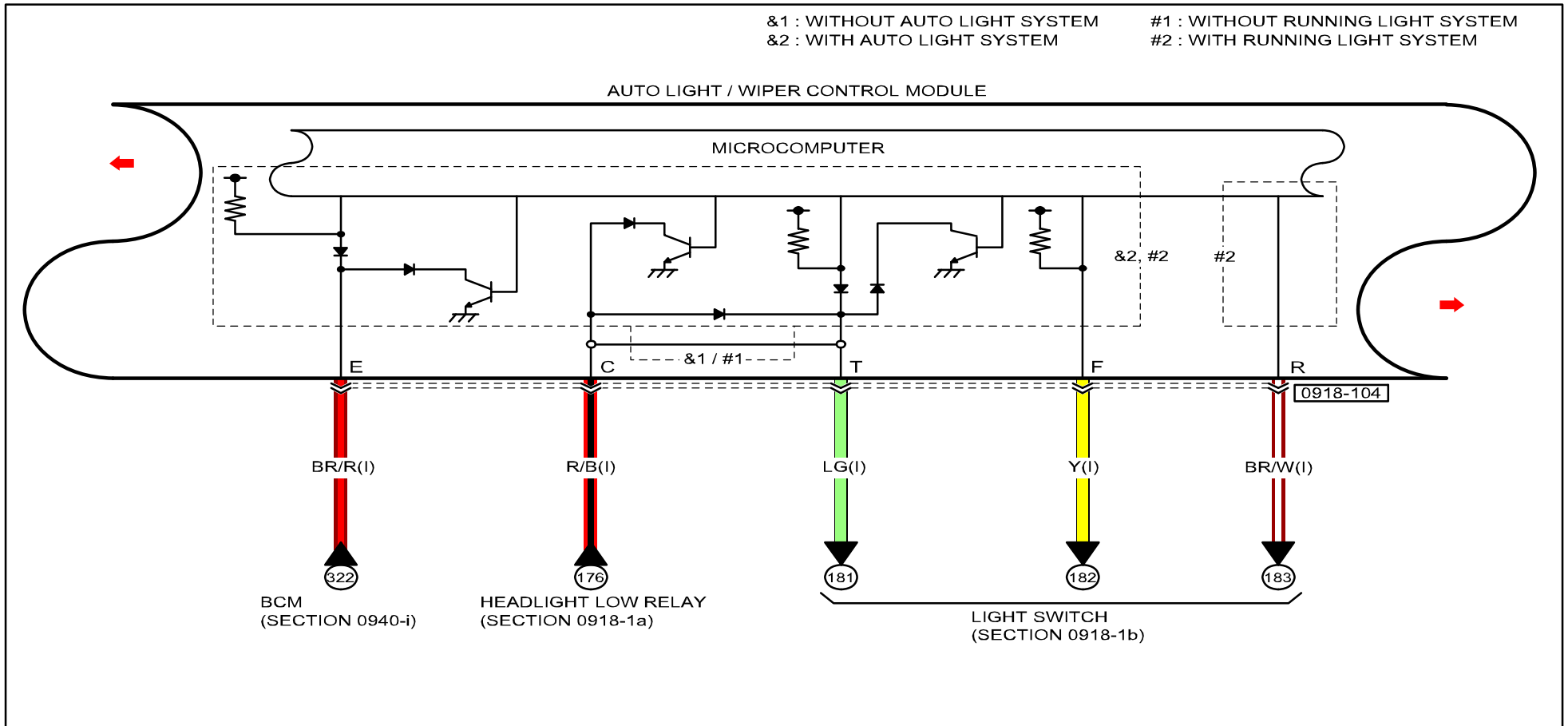



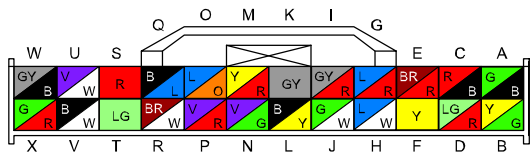

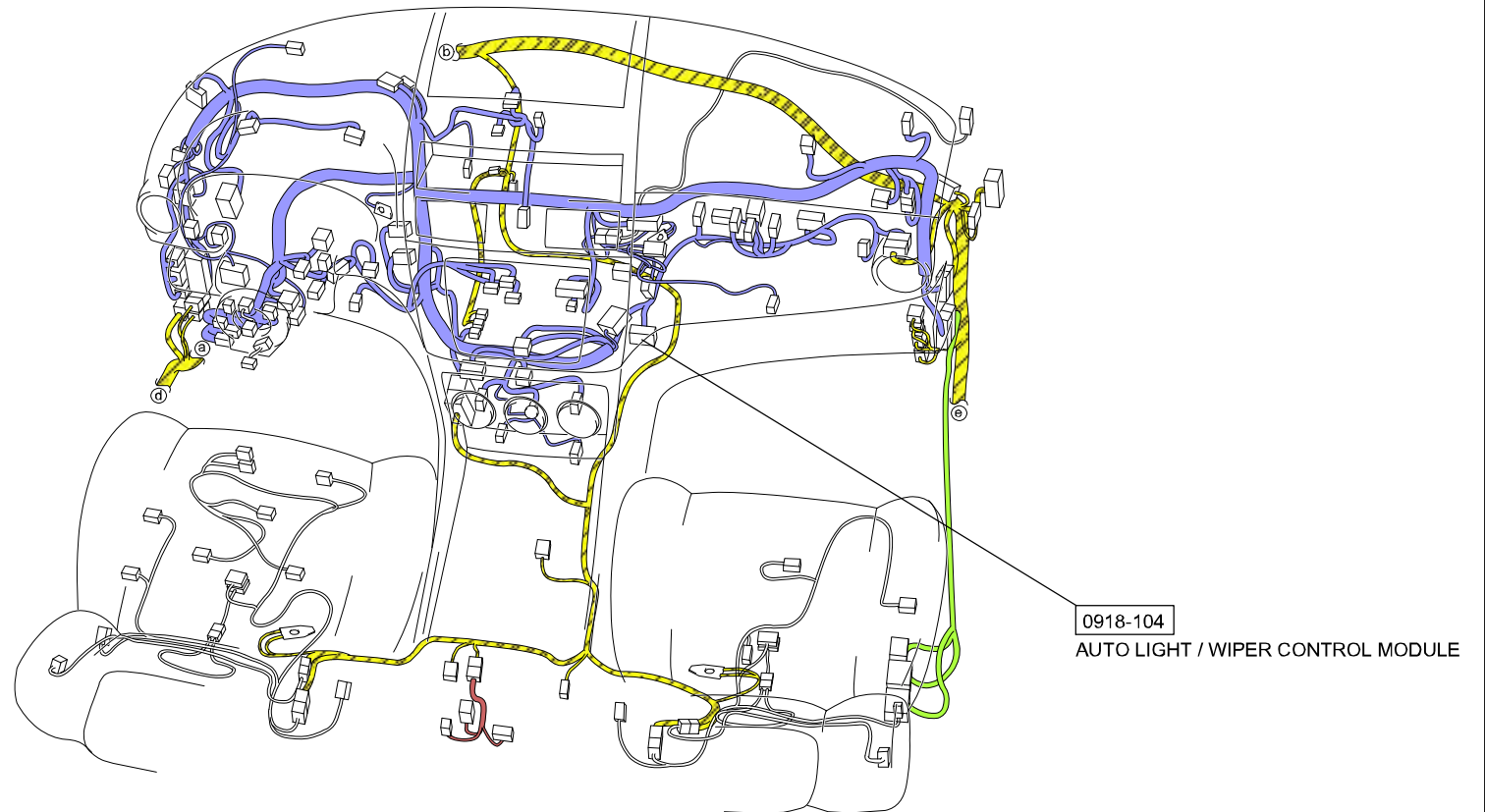
0918-104
 AUTO LIGHT / WIPER CONTROL MODULE





0918-104
AUTO LIGHT / WIPER CONTROL MODULE

-  : REAR HARNESS
-  : REAR NO.5 HARNESS
-  : INSTRUMENT PANEL HARNESS
-  : FLOOR HARNESS

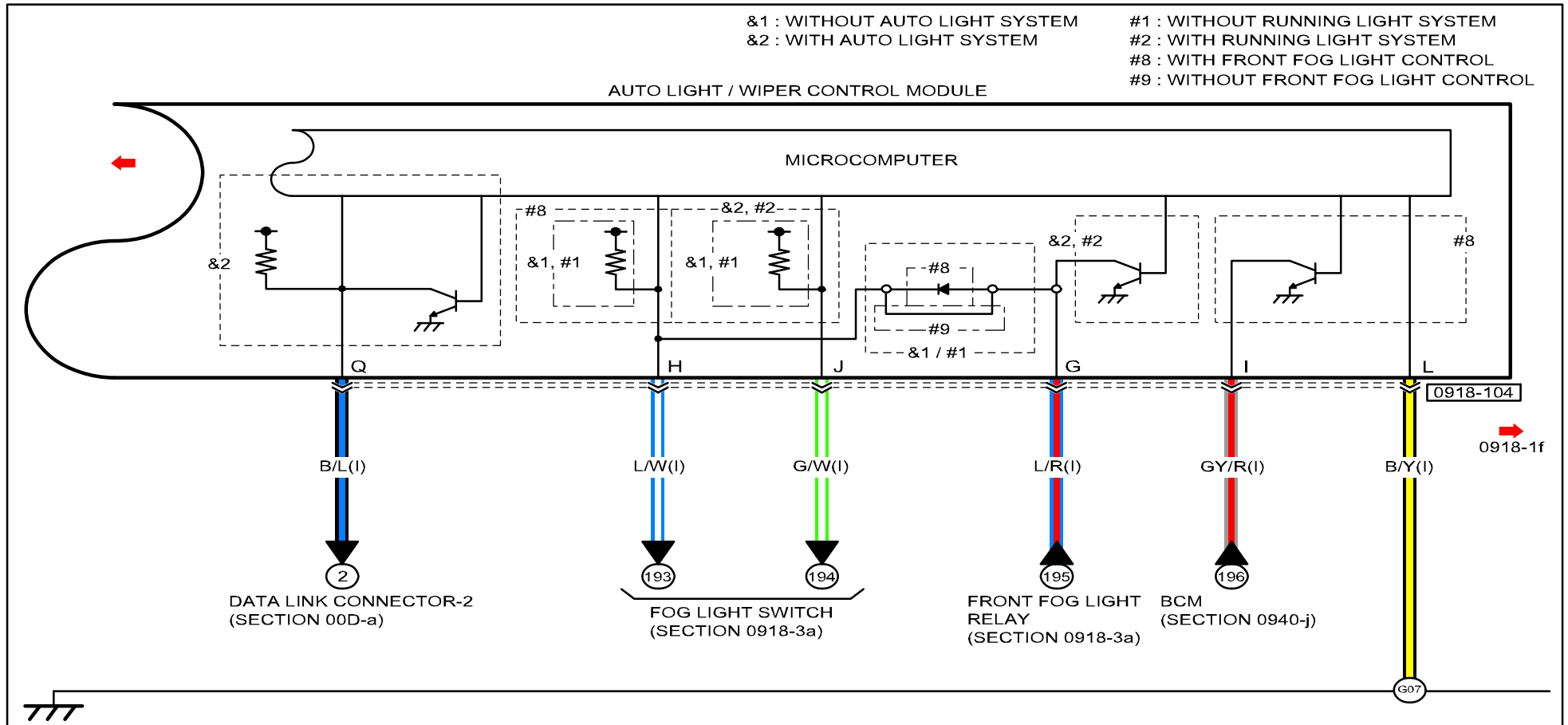



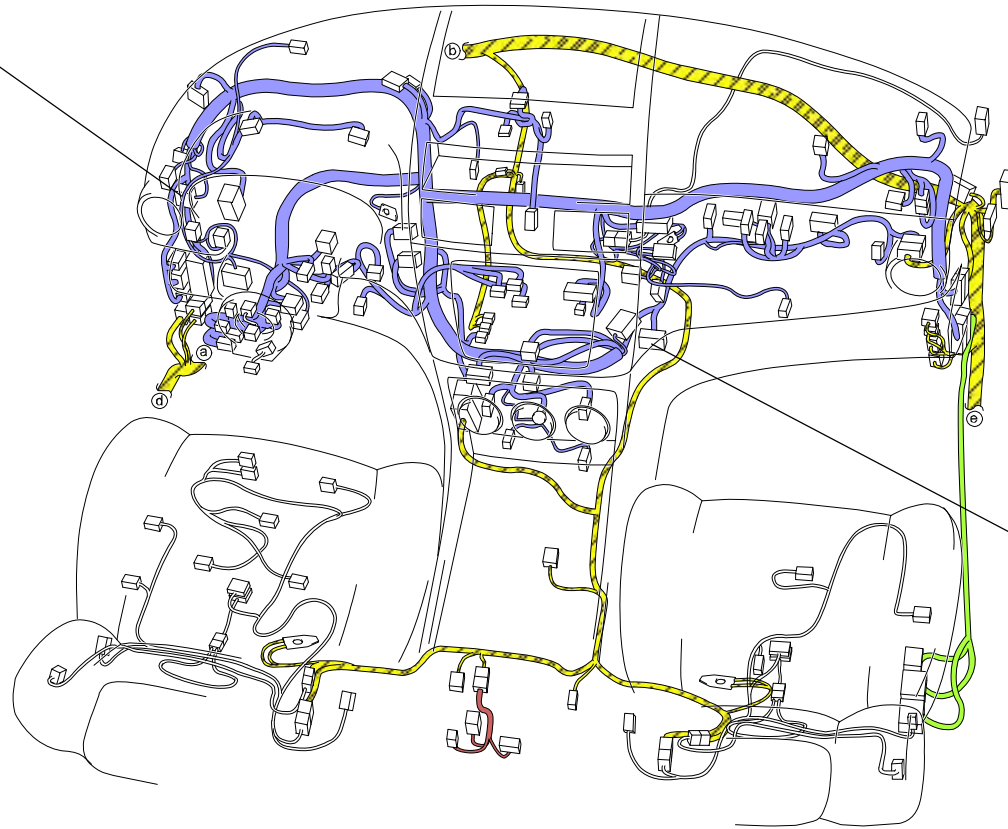

<p>0918-104 AUTO LIGHT / WIPER CONTROL MODULE</p>				

G07



0918-104
AUTO LIGHT / WIPER CONTROL MODULE

-  : REAR HARNESS
-  : REAR NO.5 HARNESS
-  : INSTRUMENT PANEL HARNESS
-  : FLOOR HARNESS

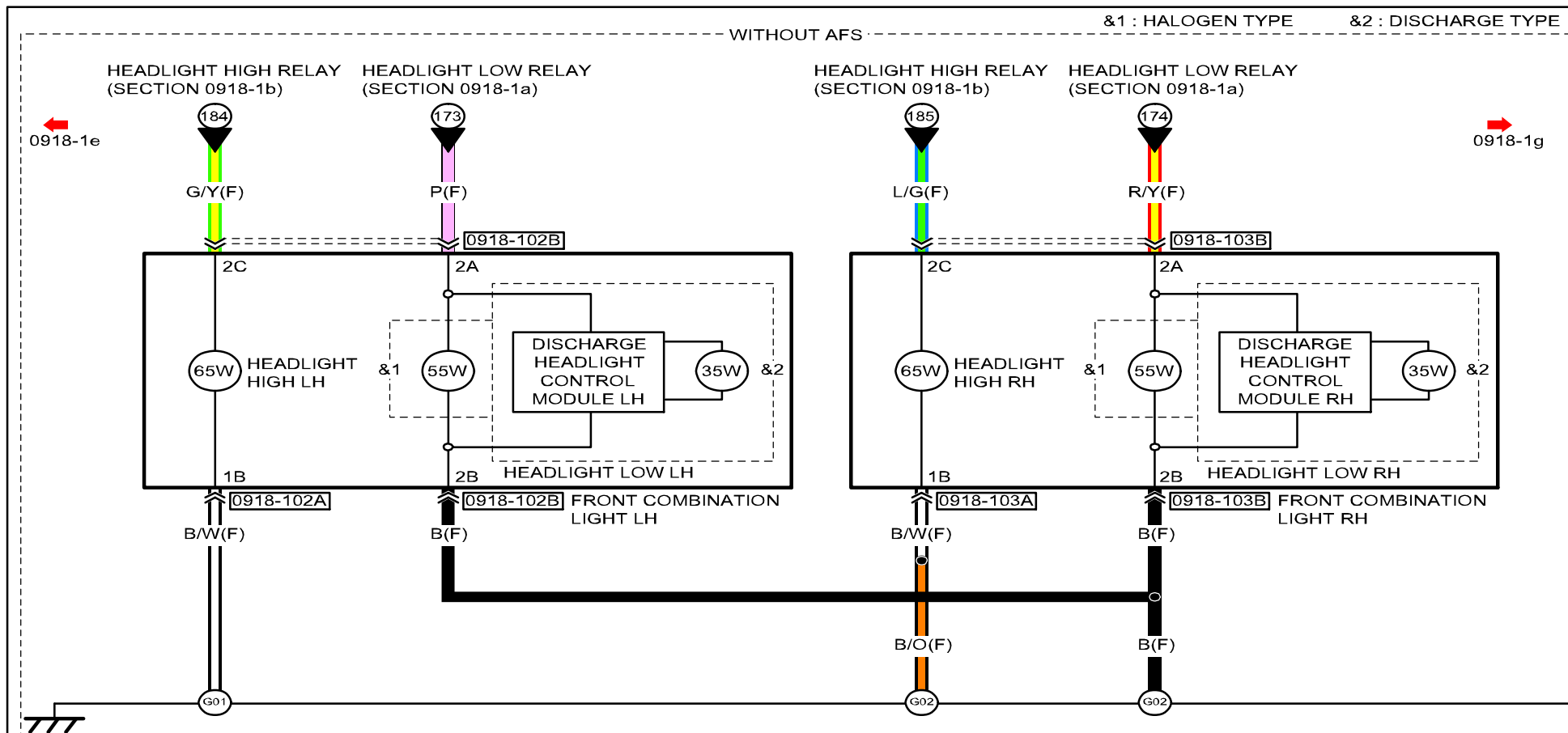

0918-102A
FRONT COMBINATION LIGHT LH /
HEADLIGHT LEVELING ACTUATOR LH

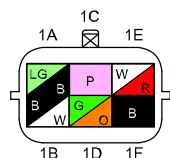

0918-102B
FRONT COMBINATION LIGHT LH

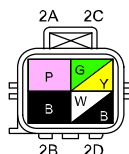

0918-103A
FRONT COMBINATION LIGHT RH /
HEADLIGHT LEVELING ACTUATOR RH

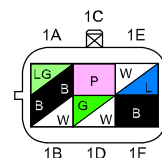

0918-103B
FRONT COMBINATION LIGHT RH

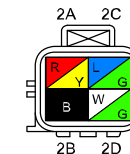

HEADLIGHT

0918-1f

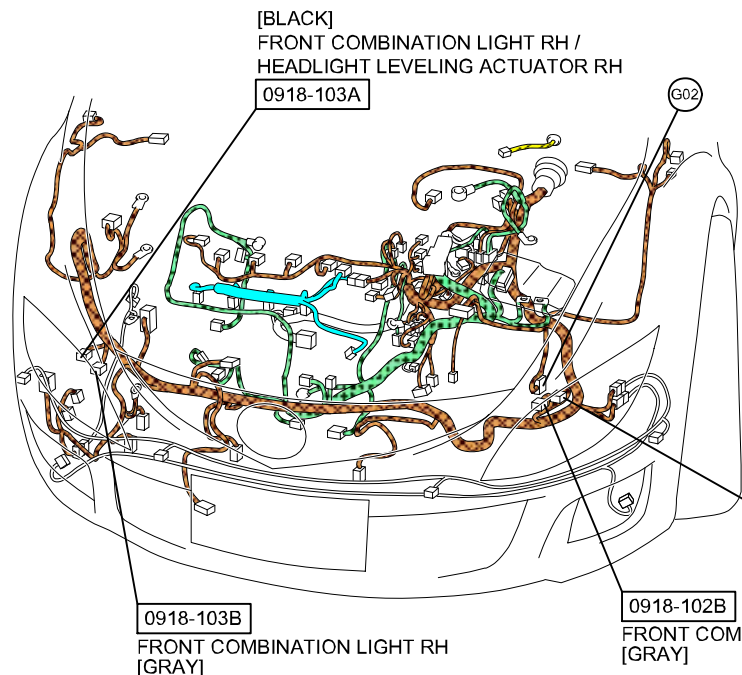



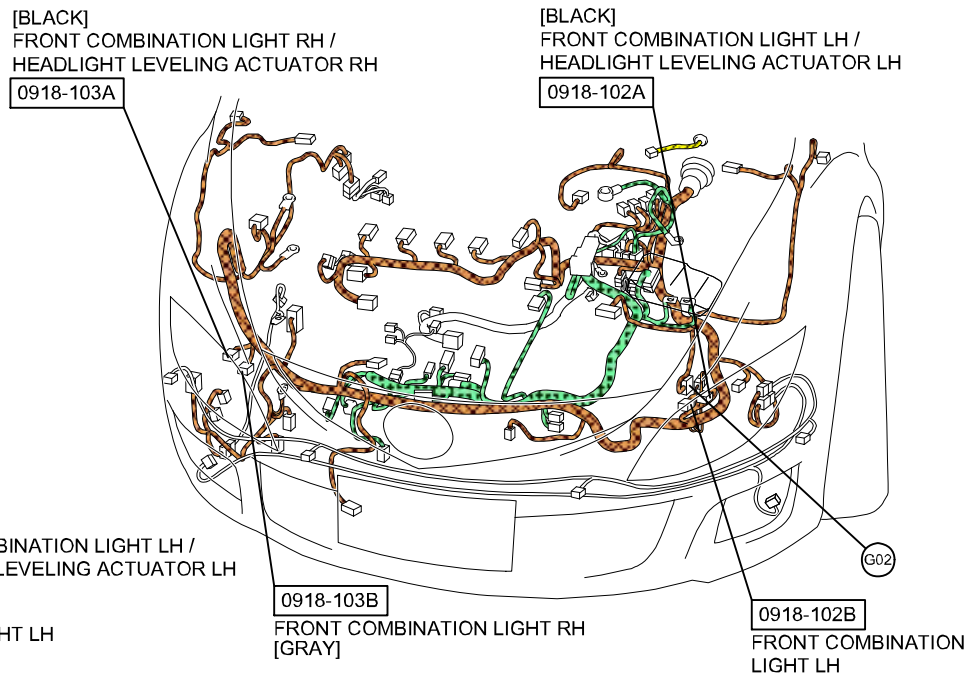

[EXCEPT MZR-CD (RF Turbo)]

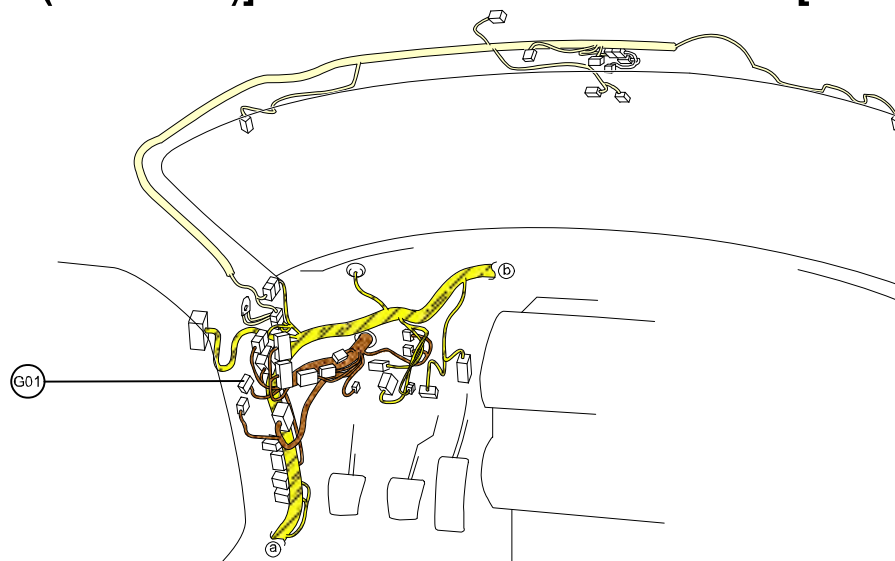

[MZR-CD (RF Turbo)]



-  : FRONT HARNESS
-  : ENGINE HARNESS
-  : INJECTION HARNESS
-  : REAR HARNESS
-  : INTERIOR LIGHT NO.2 HARNESS

HEADLIGHT

0918-1g

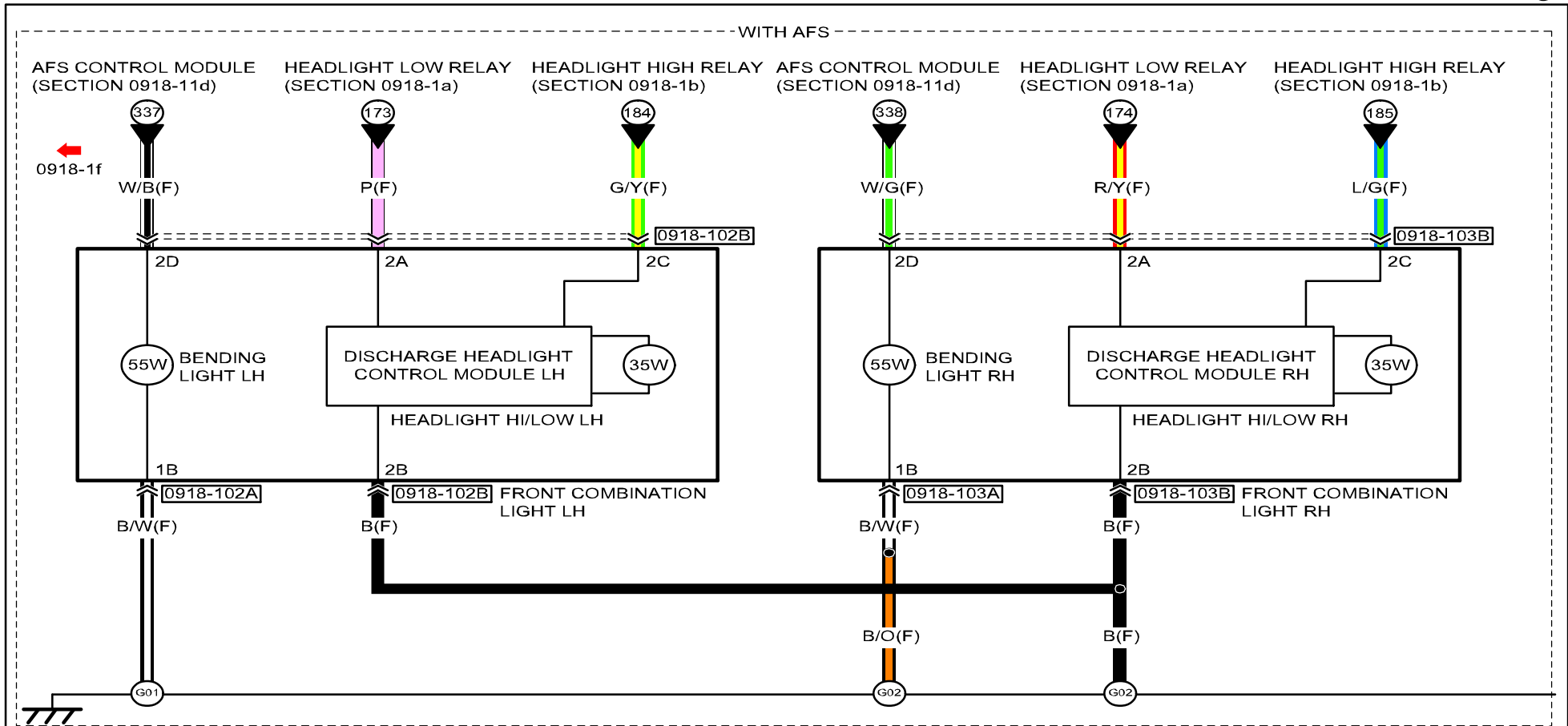

0918-102A
FRONT COMBINATION LIGHT LH /
HEADLIGHT LEVELING ACTUATOR LH

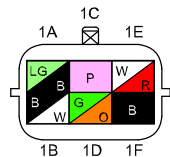

0918-102B
FRONT COMBINATION LIGHT LH

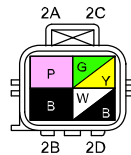

0918-103A
FRONT COMBINATION LIGHT RH /
HEADLIGHT LEVELING ACTUATOR RH

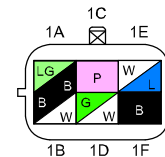

0918-103B
FRONT COMBINATION LIGHT RH

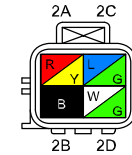

HEADLIGHT

0918-1g

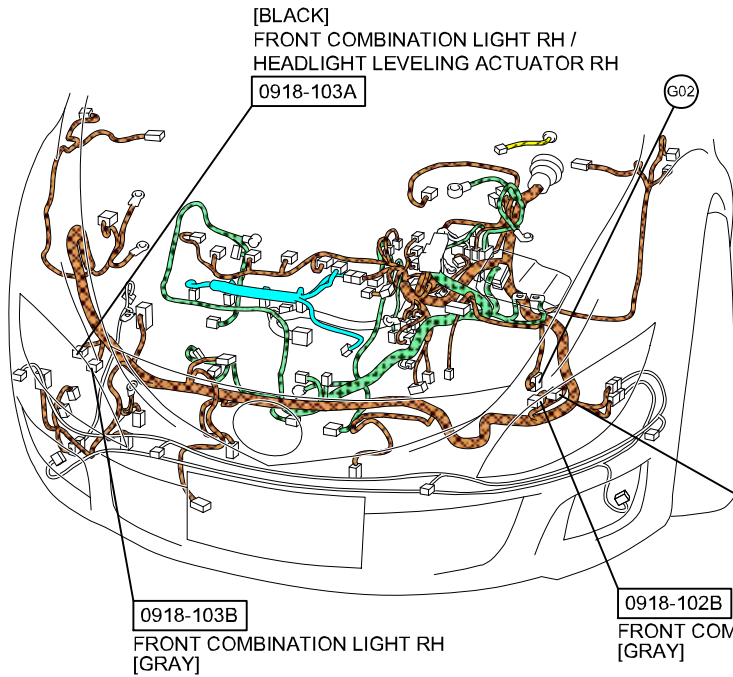

[EXCEPT MZR-CD (RF Turbo)]

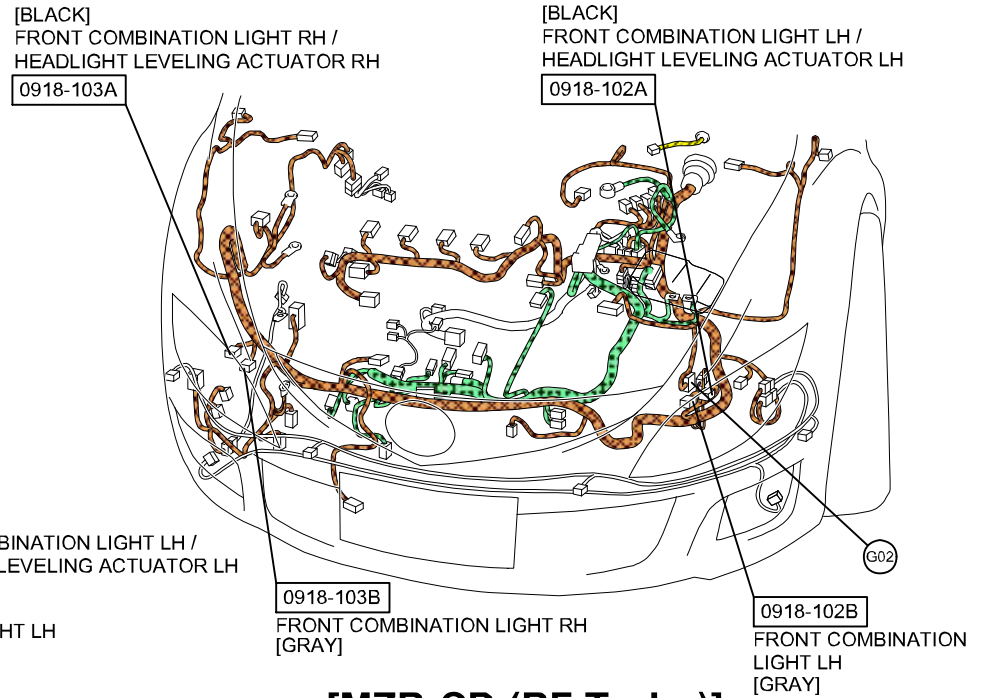

[MZR-CD (RF Turbo)]



- : FRONT HARNESS
- : ENGINE HARNESS
- : INJECTION HARNESS
- : REAR HARNESS
- : INTERIOR LIGHT NO.2 HARNESS

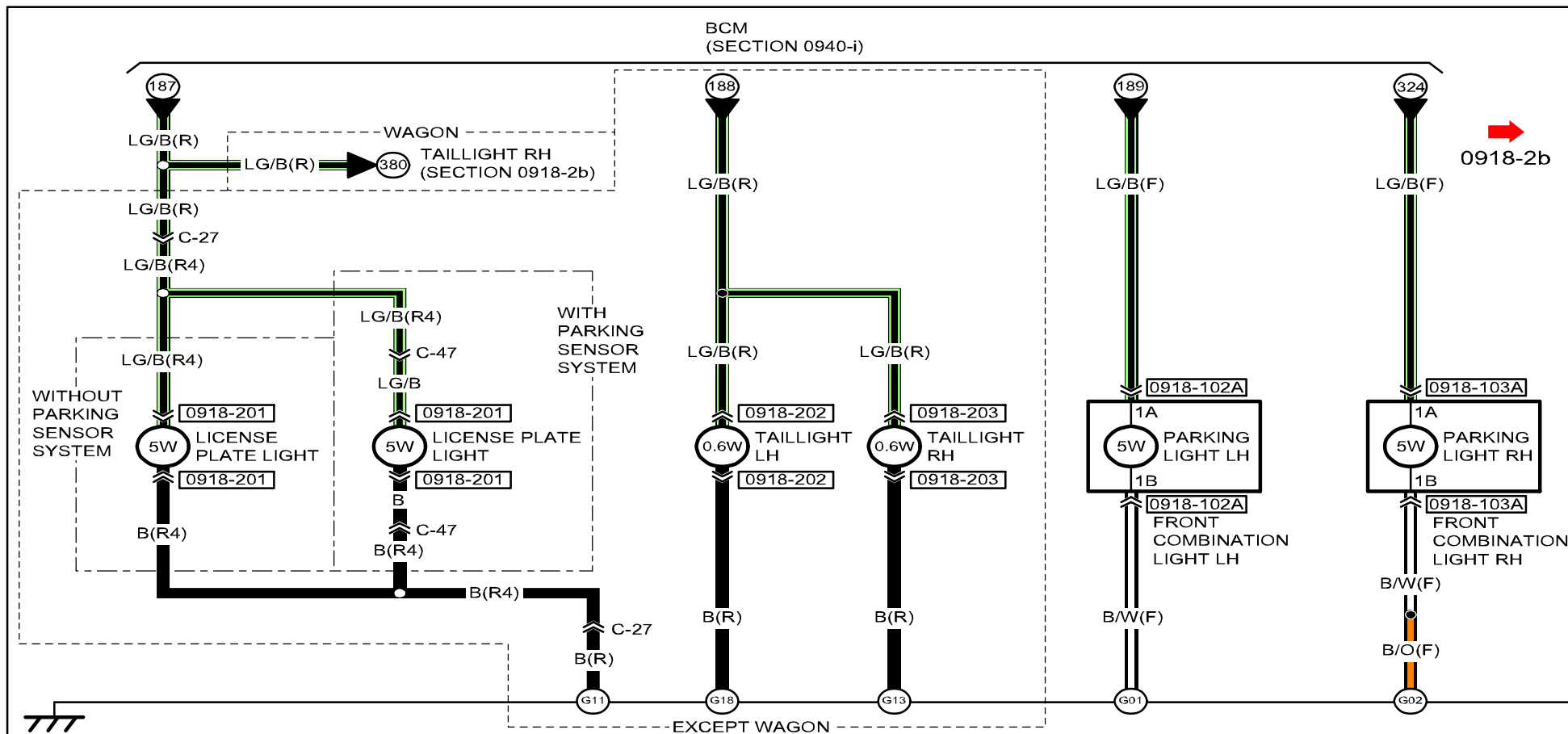

0918-201 LICENSE PLATE LIGHT

(WITHOUT PARKING SENSOR SYSTEM)

(WITH PARKING SENSOR SYSTEM)

0918-102A FRONT COMBINATION LIGHT LH / HEADLIGHT LEVELING ACTUATOR LH

0918-103A FRONT COMBINATION LIGHT RH / HEADLIGHT LEVELING ACTUATOR RH

0918-202 TAILLIGHT LH / BRAKE LIGHT LH

4SD / General (L.H.D.) specs. :

0918-203 TAILLIGHT RH / BRAKE LIGHT RH

[EXCEPT MZR-CD (RF Turbo)]

[BLACK]
FRONT COMBINATION LIGHT LH /
HEADLIGHT LEVELING ACTUATOR LH
0918-102A

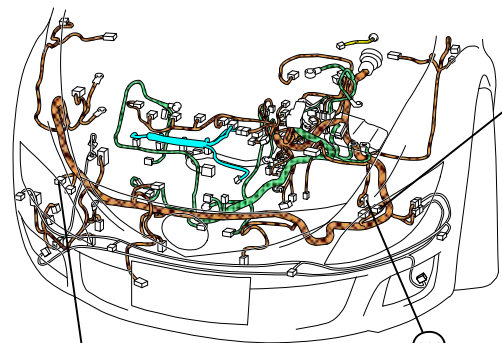

0918-103A
FRONT COMBINATION LIGHT RH /
HEADLIGHT LEVELING ACTUATOR RH
[BLACK]

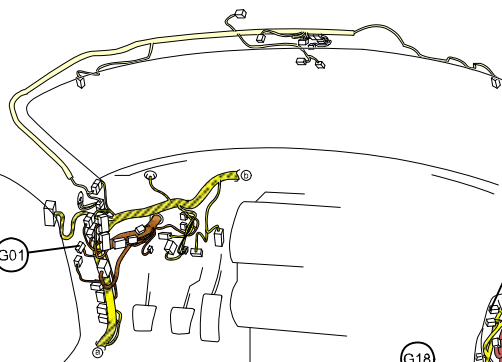

TAILLIGHT LH /
BRAKE LIGHT LH
0918-202

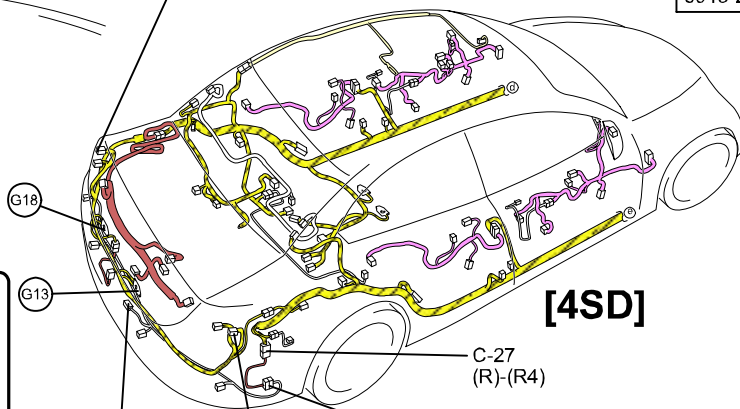

TAILLIGHT LH /
BRAKE LIGHT LH
0918-202

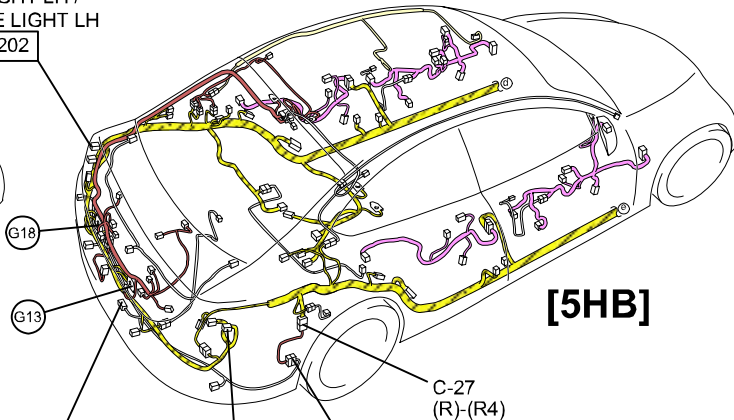

[MZR-CD (RF Turbo)]

0918-103A
FRONT COMBINATION LIGHT RH /
HEADLIGHT LEVELING ACTUATOR RH
[BLACK]

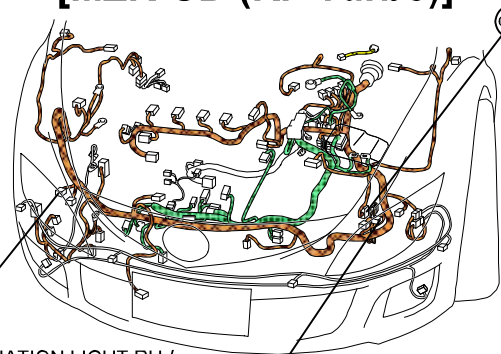

0918-102A
FRONT COMBINATION LIGHT LH /
HEADLIGHT LEVELING ACTUATOR LH
[BLACK]

[4SD]

[5HB]

- : FRONT HARNESS
- : ENGINE HARNESS
- : INJECTION HARNESS
- : REAR HARNESS
- : REAR NO.2 HARNESS
- : REAR NO.3 HARNESS
- : REAR NO.4 HARNESS
- : REAR NO.5 HARNESS
- : DOOR HARNESS
- : INSTRUMENT PANEL HARNESS
- : FLOOR HARNESS
- : INTERIOR LIGHT HARNESS
- : INTERIOR LIGHT NO.2 HARNESS

0918-201 ← WITH PARKING SENSOR SYSTEM LICENSE PLATE LIGHT [GRAY]

0918-203
TAILLIGHT RH /
BRAKE LIGHT RH

0918-201 ← WITHOUT PARKING SENSOR SYSTEM LICENSE PLATE LIGHT [BLACK] WITH PARKING C-47 ← SENSOR SYSTEM (R4)-SHORT CORD [GRAY]

0918-201 ← WITH PARKING SENSOR SYSTEM LICENSE PLATE LIGHT [GRAY]

0918-201 ← WITHOUT PARKING SENSOR SYSTEM LICENSE PLATE LIGHT [BLACK] WITH PARKING C-47 ← SENSOR SYSTEM (R4)-SHORT CORD [GRAY]

0918-203
TAILLIGHT RH /
BRAKE LIGHT RH

C-27 (R)-(R4)

C-27 (R)-(R4)

G18

G18

G13

G13

G11

G02

G02

G01

C-27
REAR HARNESS-REAR NO.4 HARNESS

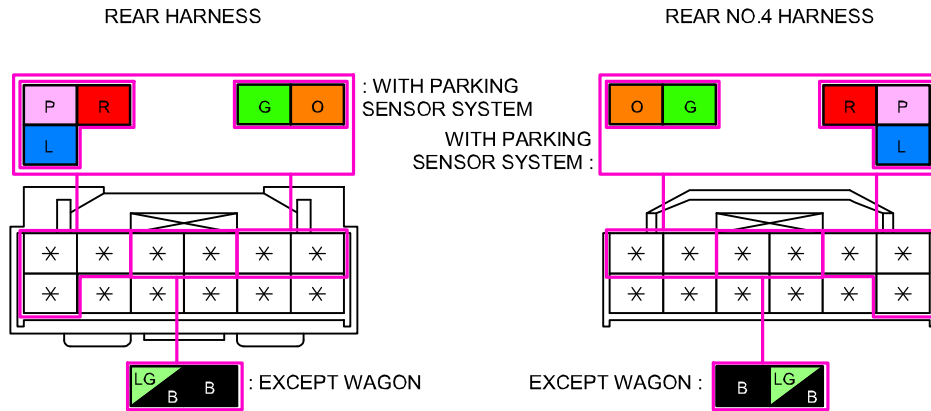

C-47
REAR NO.4 HARNESS-SHORT CORD

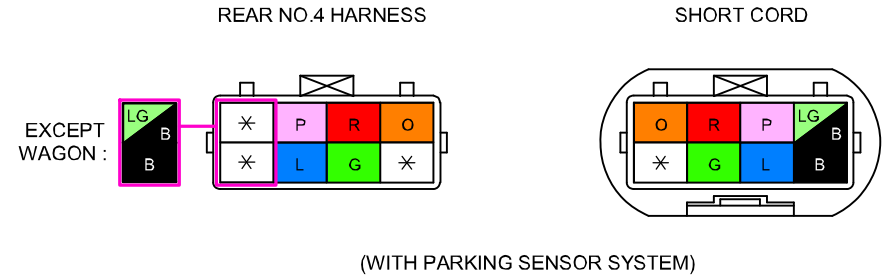

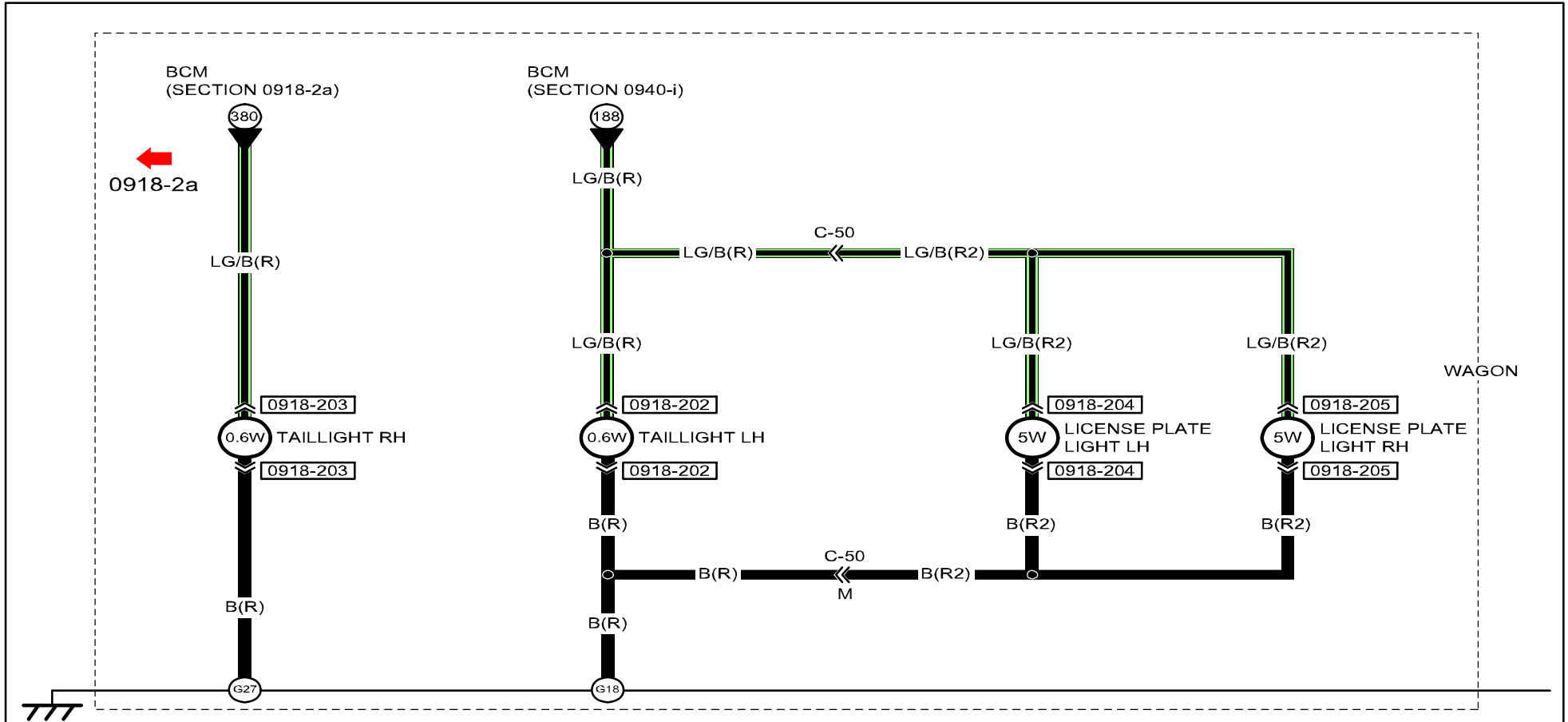

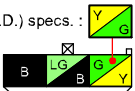
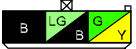
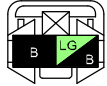
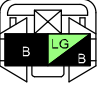
<p>0918-202 TAILLIGHT LH / BRAKE LIGHT LH</p> <p>4SD / General (L.H.D.) specs. :</p> 	<p>0918-203 TAILLIGHT RH / BRAKE LIGHT RH</p> 	<p>0918-204 LICENSE PLATE LIGHT LH</p> 	
<p>0918-205 LICENSE PLATE LIGHT RH</p> 			

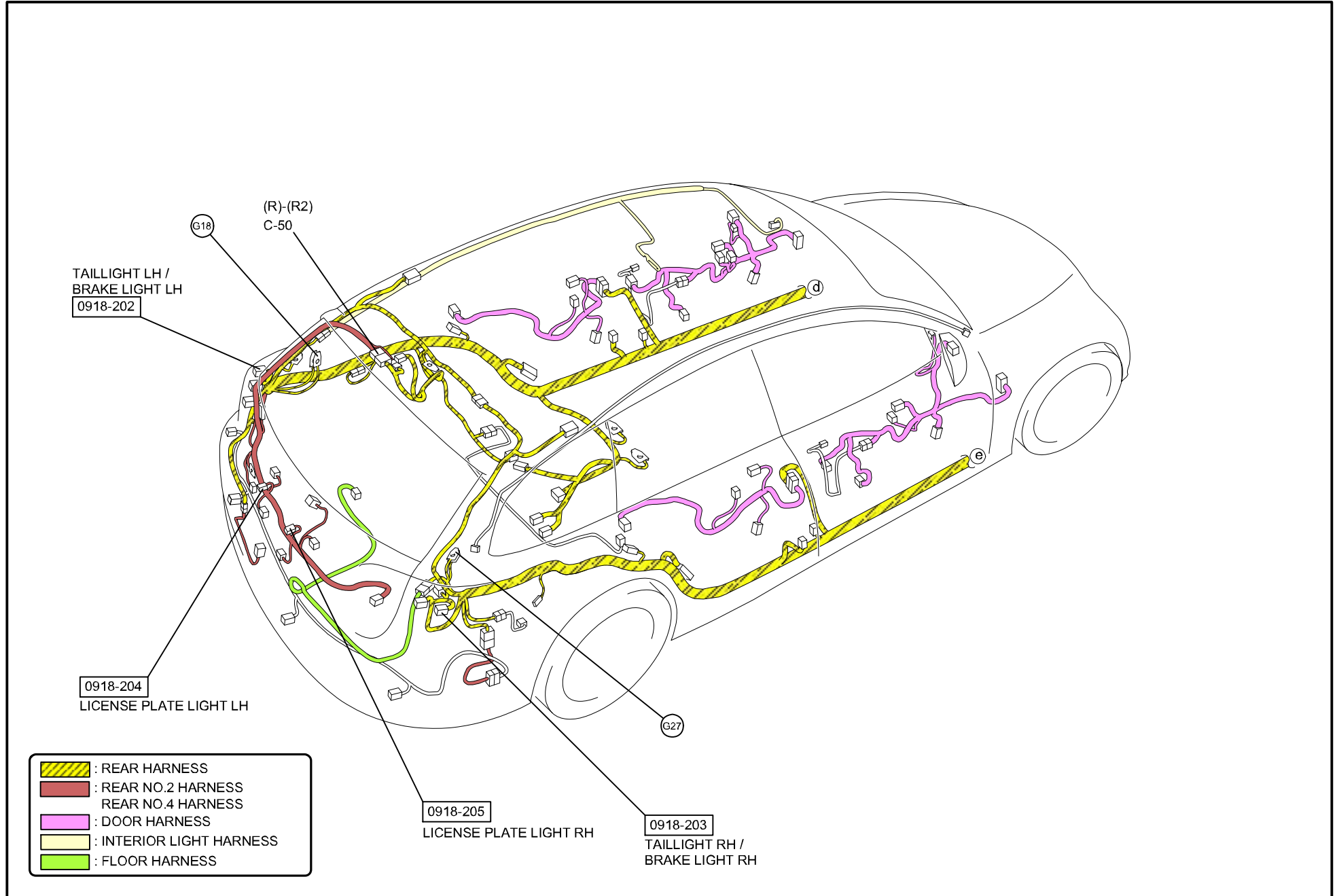

C-50
 REAR HARNESS-REAR NO.2 HARNESS

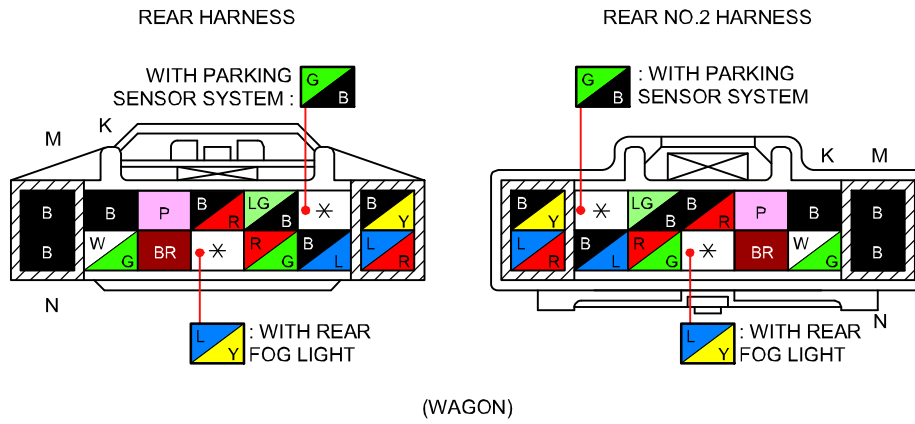

FOG LIGHT

0918-3a

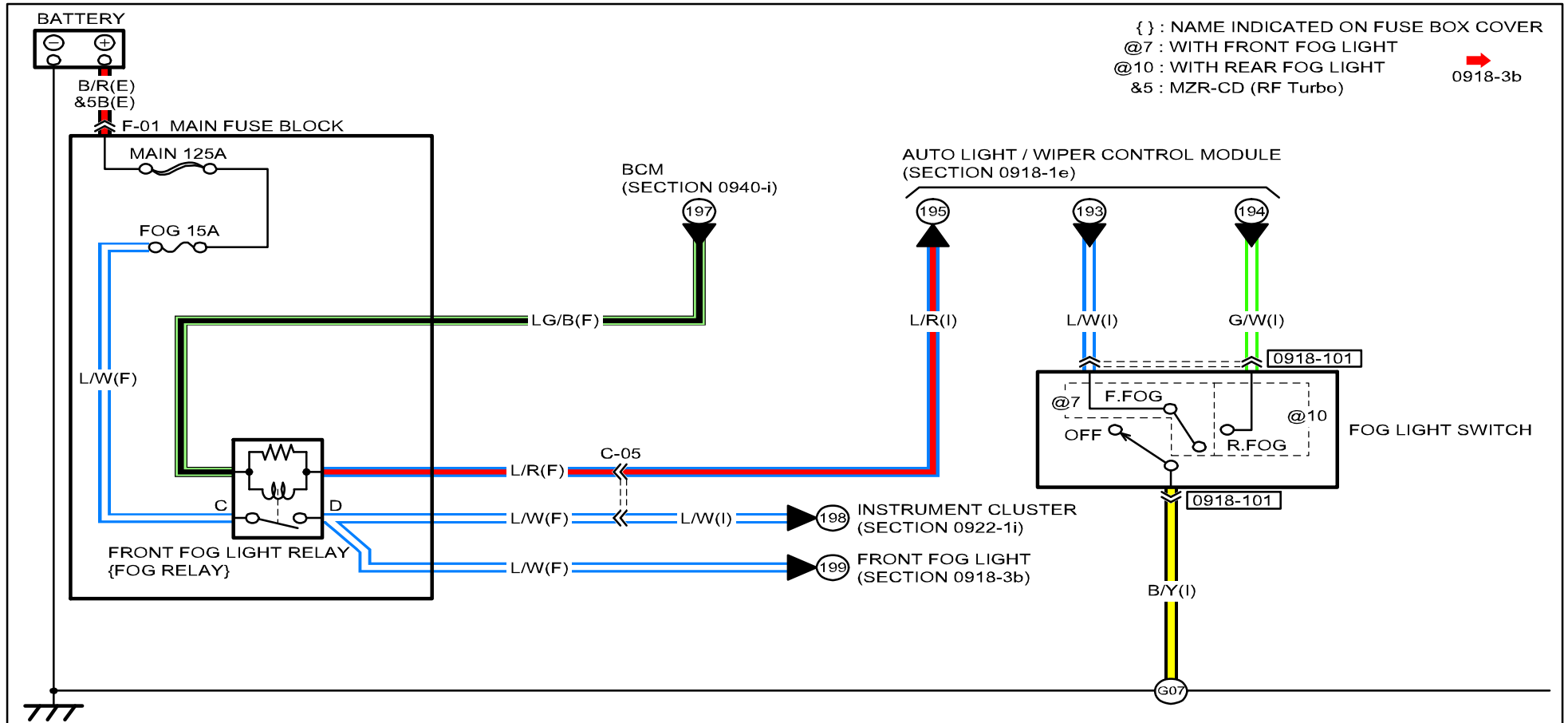

<p>0918-101 LIGHT SWITCH / FOG LIGHT SWITCH / TURN SWITCH</p>					

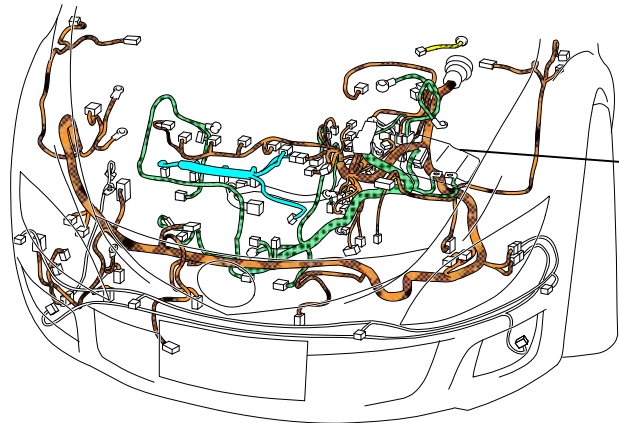

F-01
MAIN FUSE BLOCK
(REFER TO 00F SECTION)

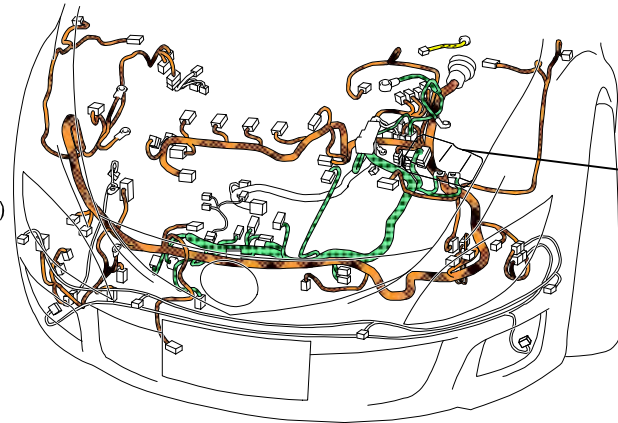

F-01
MAIN FUSE BLOCK
(REFER TO 00F SECTION)

[EXCEPT MZR-CD (RF Turbo)]

[MZR-CD (RF Turbo)]

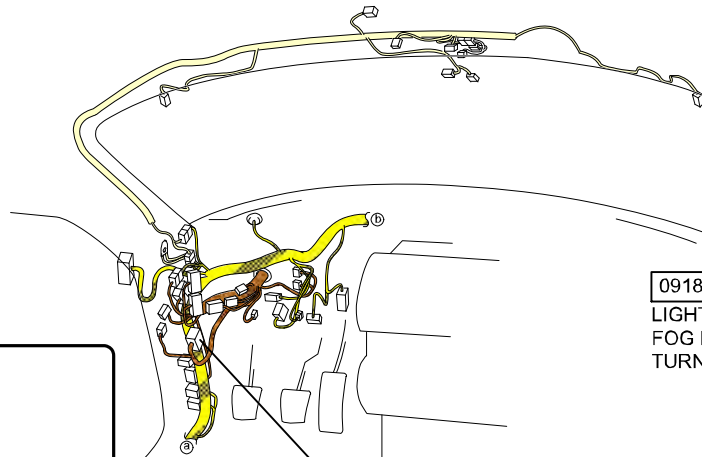







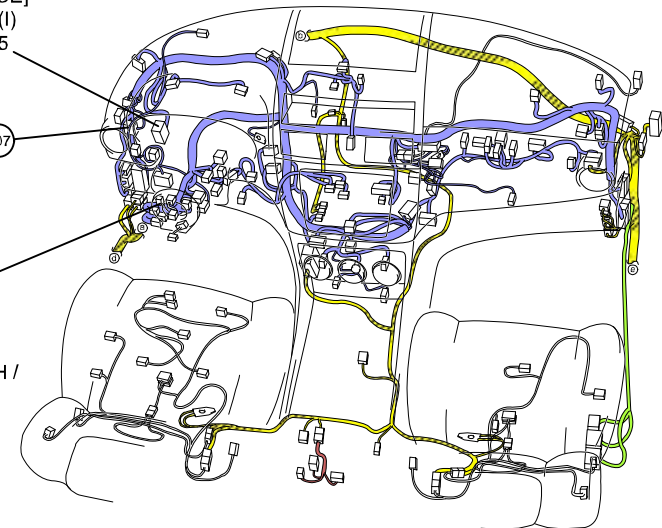

C-05
(F)-(I)
[BLUE]

[BLUE]
(F)-(I)
C-05

0918-101
LIGHT SWITCH /
FOG LIGHT SWITCH /
TURN SWITCH

G07



-  : FRONT HARNESS
-  : ENGINE HARNESS
-  : INJECTION HARNESS
-  : REAR HARNESS
-  : REAR NO.5 HARNESS
-  : INSTRUMENT PANEL HARNESS
-  : FLOOR HARNESS
-  : INTERIOR LIGHT NO.2 HARNESS

C-05

FRONT HARNESS-INSTRUMENT PANEL HARNESS

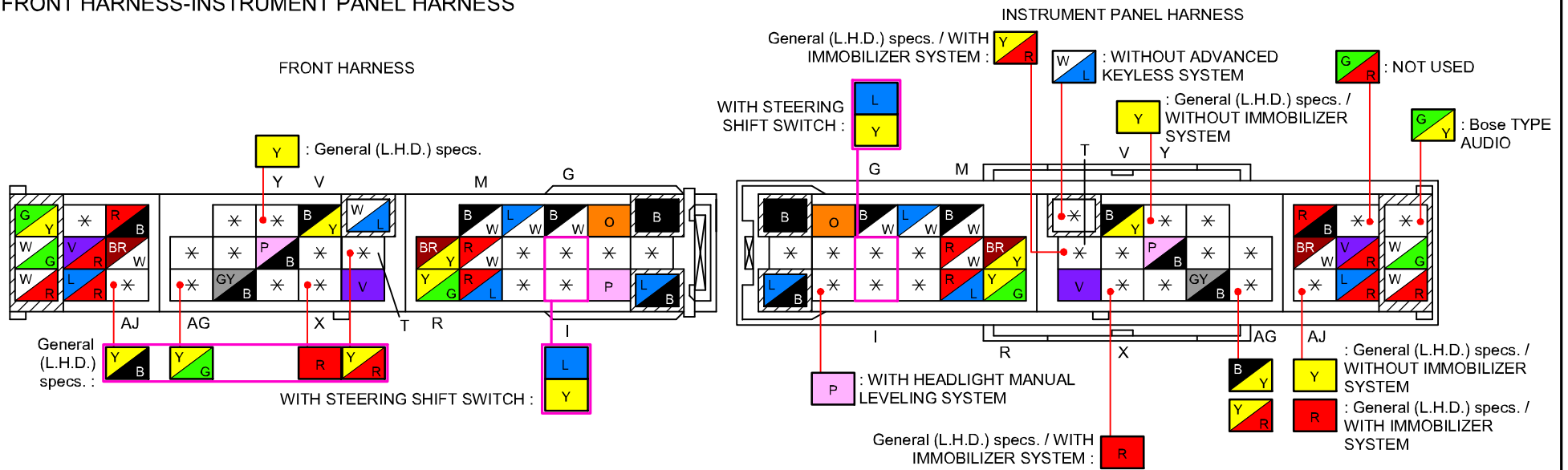

[EXCEPT MZR-CD (RF Turbo)]

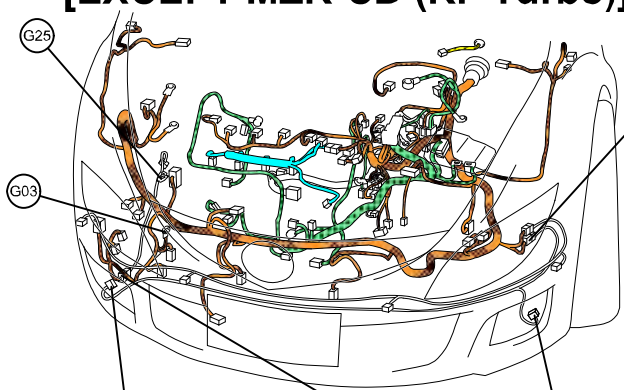

[GRAY]
(F)-SHORT CORD
0918-304

(R)-(R2)
C-35

0918-301
FRONT FOG LIGHT LH
[BLACK]

0918-302
FRONT FOG LIGHT RH
[BLACK]

C-44
(F)-SHORT CORD
[GRAY]

REAR FOG LIGHT
0918-303

[4SD]

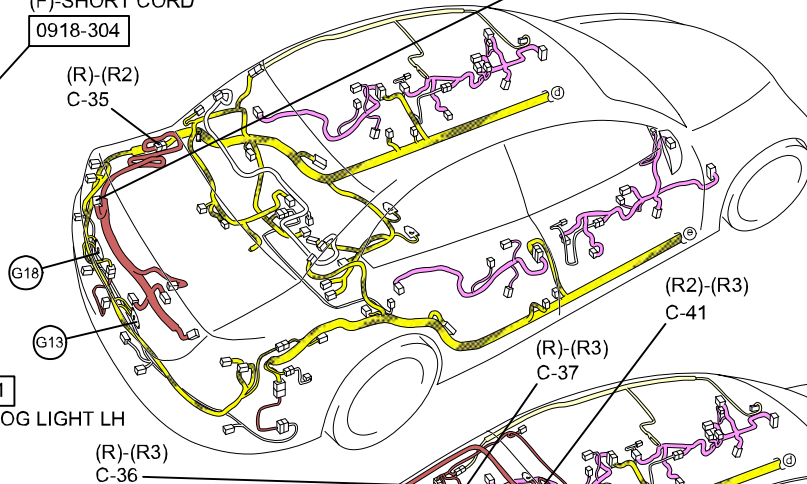

(R2)-(R3)
C-41

(R)-(R3)
C-37

(R)-(R3)
C-36

REAR FOG LIGHT
0918-303

[5HB]

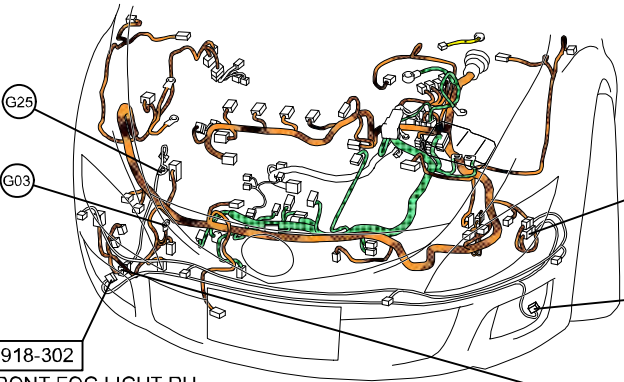

[GRAY]
(F)-SHORT CORD
0918-304

[BLACK]
FRONT FOG LIGHT LH
0918-301

0918-302
FRONT FOG LIGHT RH
[BLACK]

[MZR-CD (RF Turbo)]

C-44
(F)-SHORT CORD
[GRAY]

REAR FOG LIGHT
0918-303

C-42
(R2)-(R3)

G18

G13

(R)-(R2)
C-50









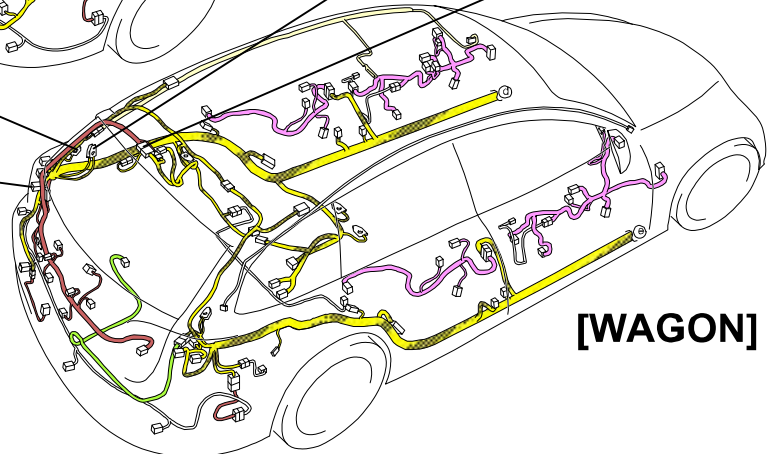

G18

REAR FOG LIGHT
0918-303

[WAGON]

G13



-  : FRONT HARNESS
-  : ENGINE HARNESS
-  : INJECTION HARNESS
-  : REAR HARNESS
-  : REAR NO.2 HARNESS
-  : REAR NO.3 HARNESS
-  : REAR NO.4 HARNESS
-  : DOOR HARNESS
-  : INTERIOR LIGHT HARNESS
-  : FLOOR HARNESS

C-35
REAR HARNESS-REAR NO.2 HARNESS

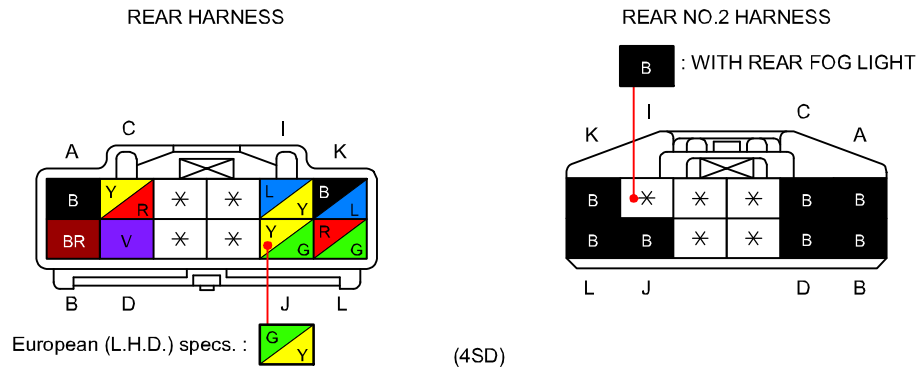

C-36
REAR HARNESS-REAR NO.3 HARNESS

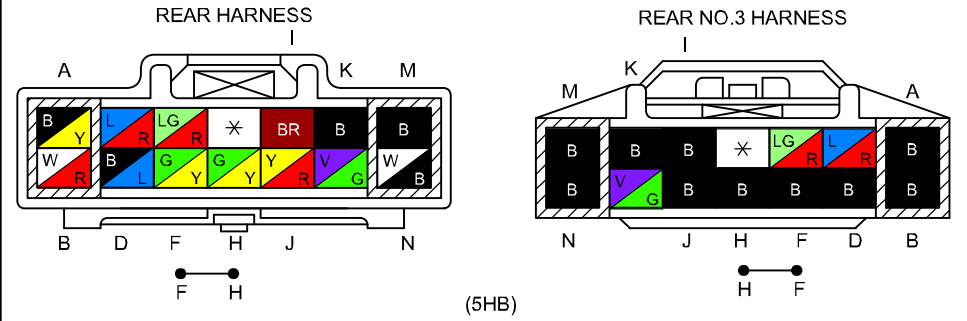

C-37
REAR HARNESS-REAR NO.3 HARNESS

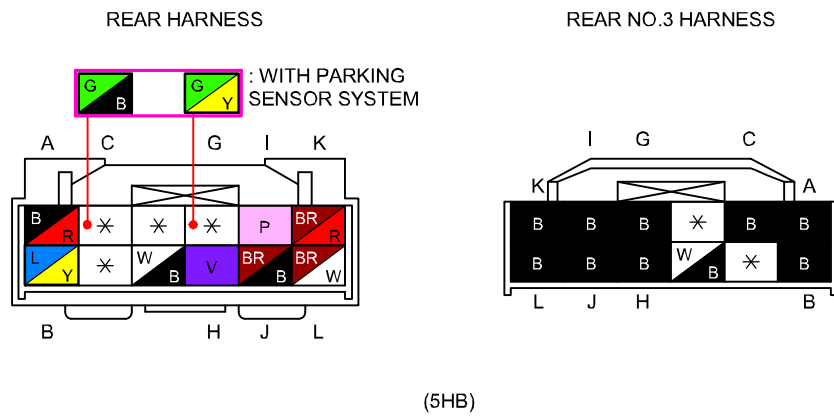

C-41
REAR NO.2 HARNESS-REAR NO.3 HARNESS

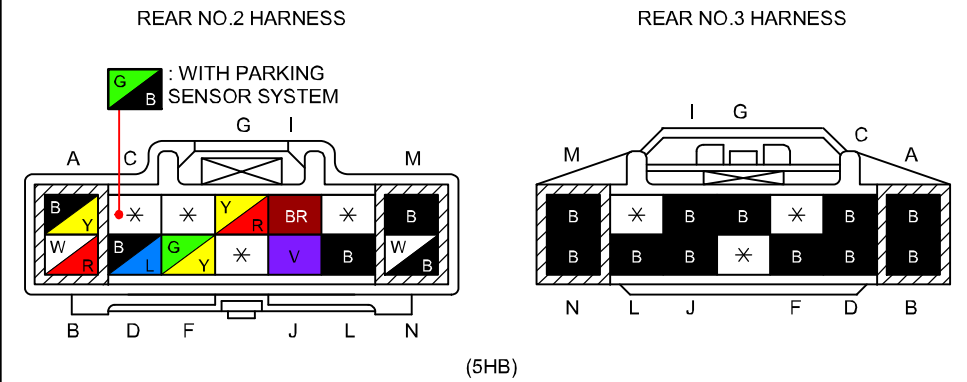

C-42
REAR NO.2 HARNESS-REAR NO.3 HARNESS

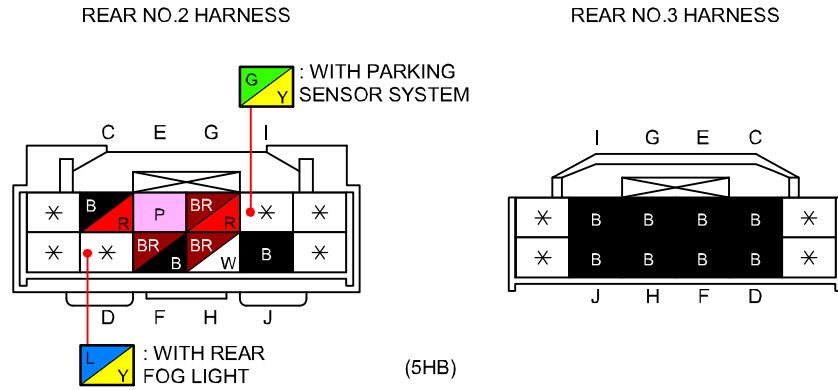

C-44
FRONT HARNESS-SHORT CORD

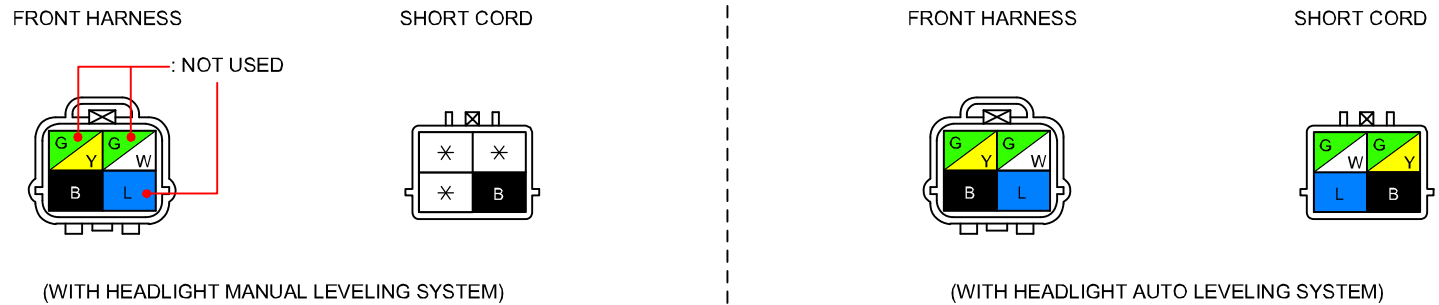

TURN AND HAZARD WARNING LIGHT

0918-4a

&4 : General (L.H.D.) specs.

0918-4b

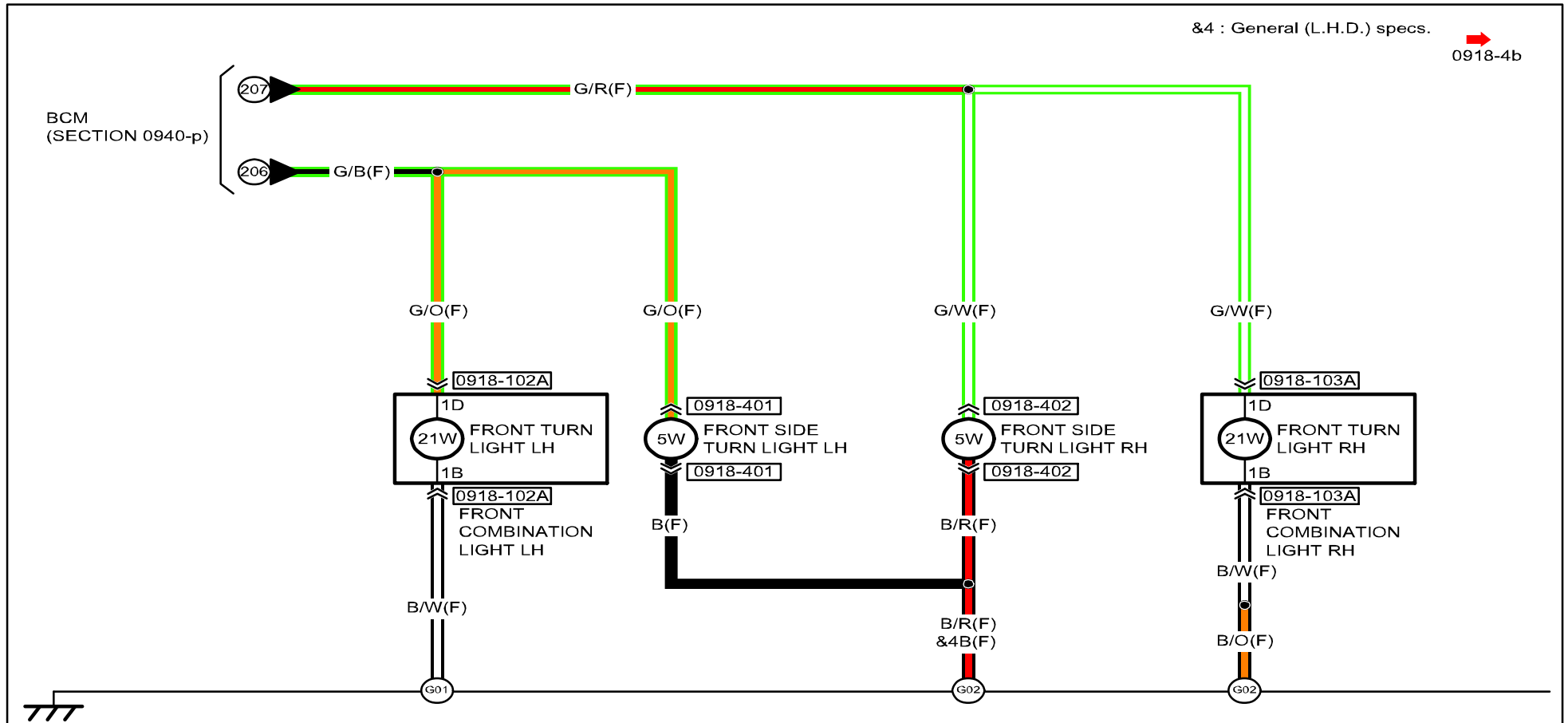

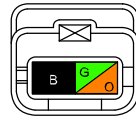
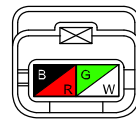
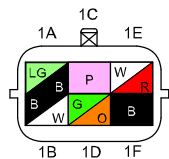
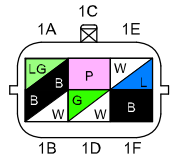
<p>0918-401 FRONT SIDE TURN LIGHT LH</p> 	<p>0918-402 FRONT SIDE TURN LIGHT RH</p> 	<p>0918-102A FRONT COMBINATION LIGHT LH / HEADLIGHT LEVELING ACTUATOR LH</p> 	<p>0918-103A FRONT COMBINATION LIGHT RH / HEADLIGHT LEVELING ACTUATOR RH</p> 	

TURN AND HAZARD WARNING LIGHT

0918-4a

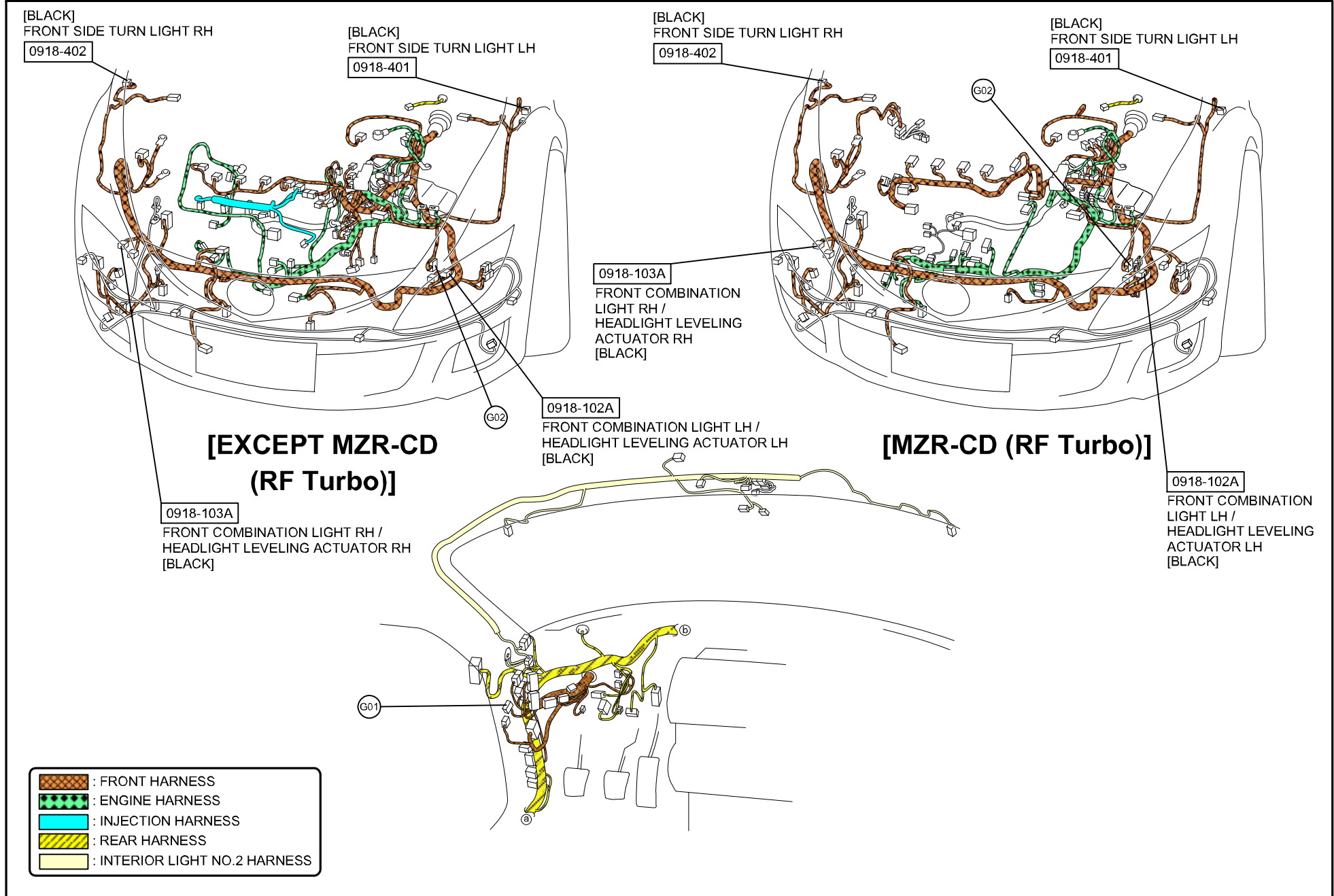

TURN AND HAZARD WARNING LIGHT

0918-4b

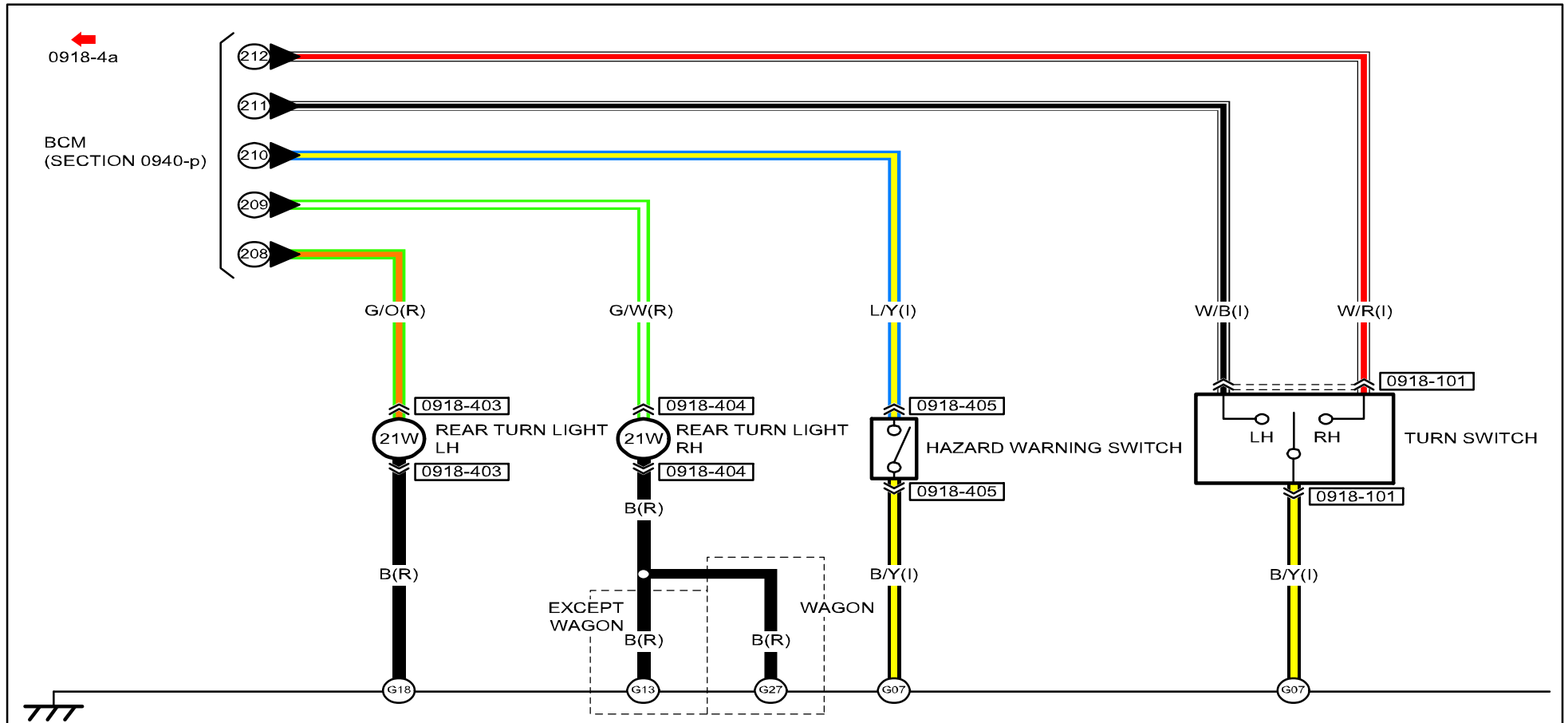

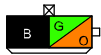
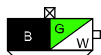
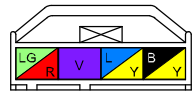
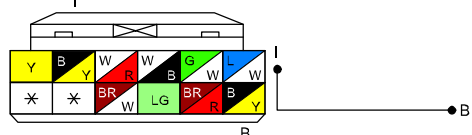
<p>0918-403 REAR TURN LIGHT LH</p> 	<p>0918-404 REAR TURN LIGHT RH</p> 	<p>0918-405 HAZARD WARNING SWITCH / HAZARD WARNING SWITCH ILLUMINATION</p> 	<p>0918-101 LIGHT SWITCH / FOG LIGHT SWITCH / TURN SWITCH</p> 	

TURN AND HAZARD WARNING LIGHT

0918-4b

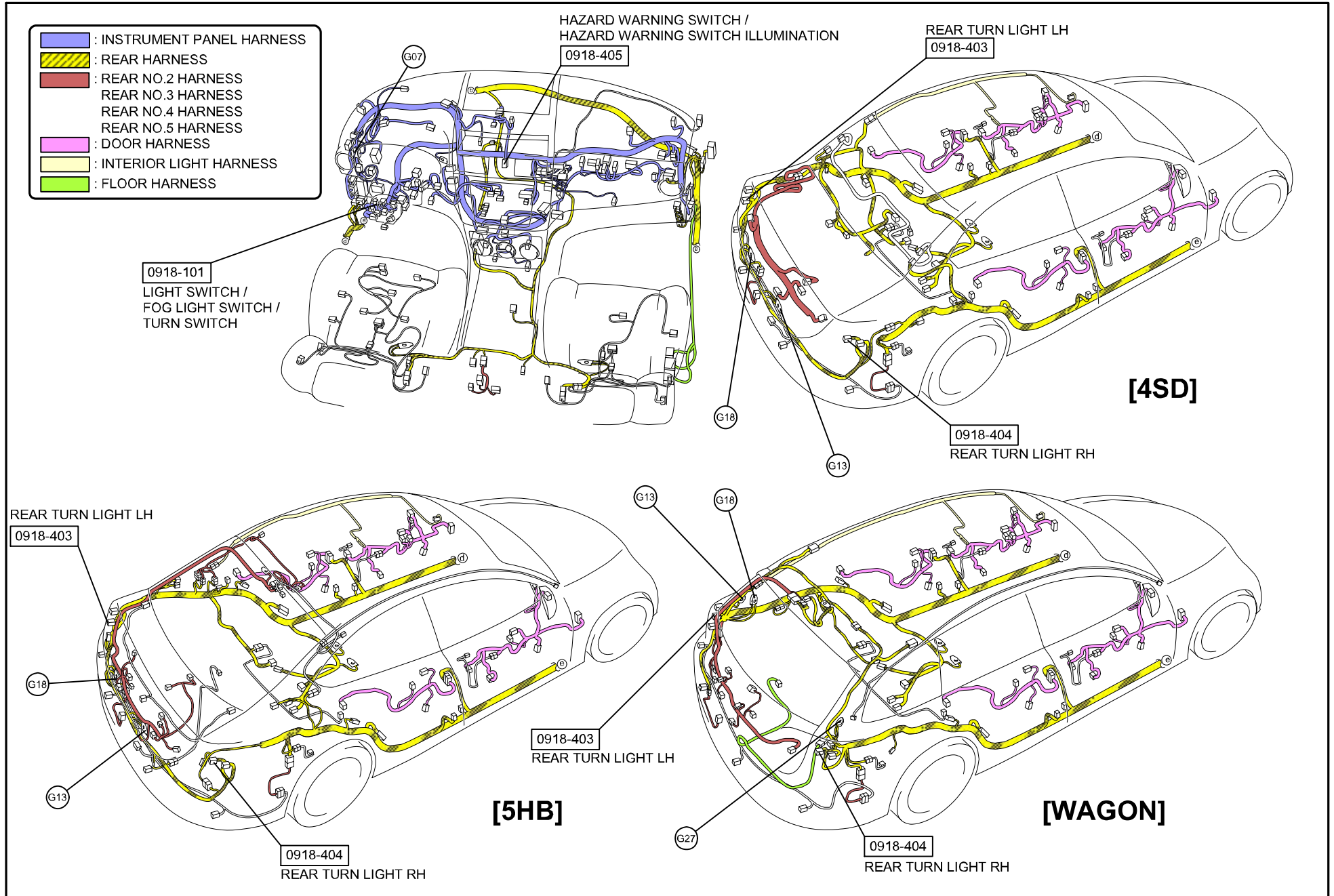

BACK-UP LIGHT

0918-5

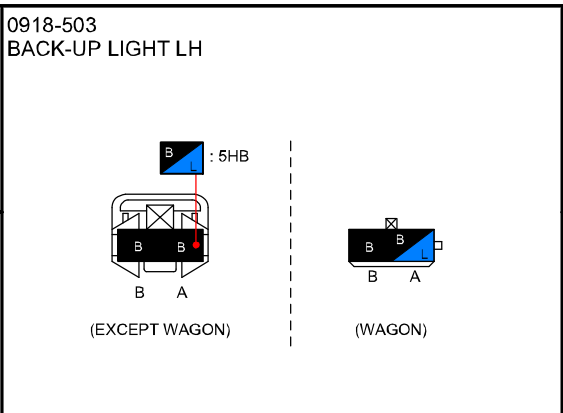
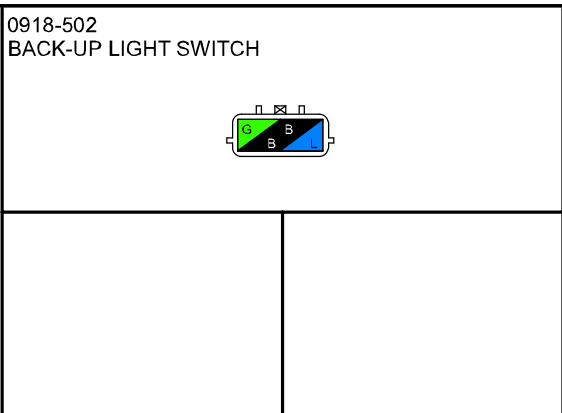
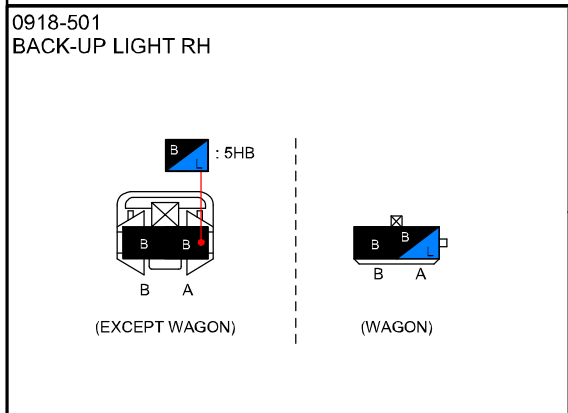
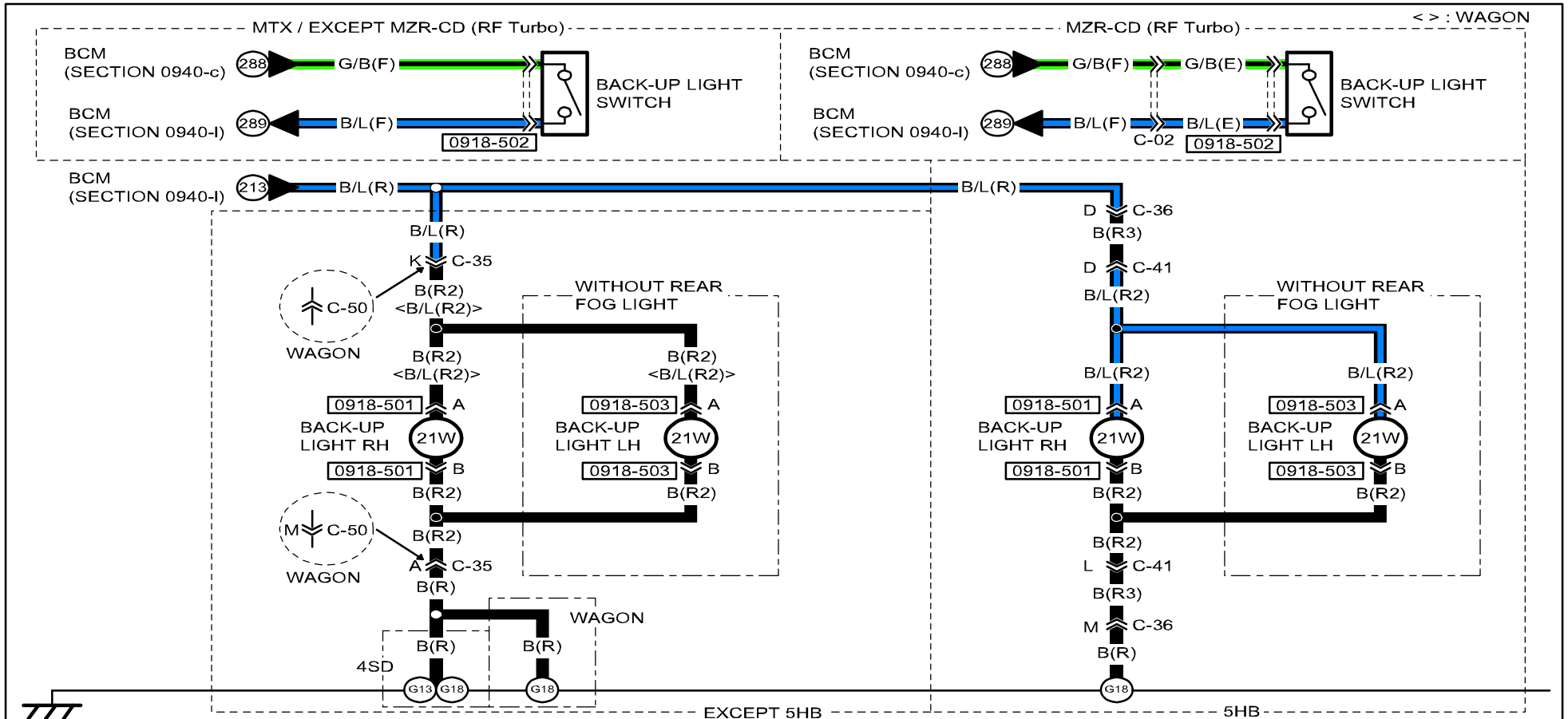

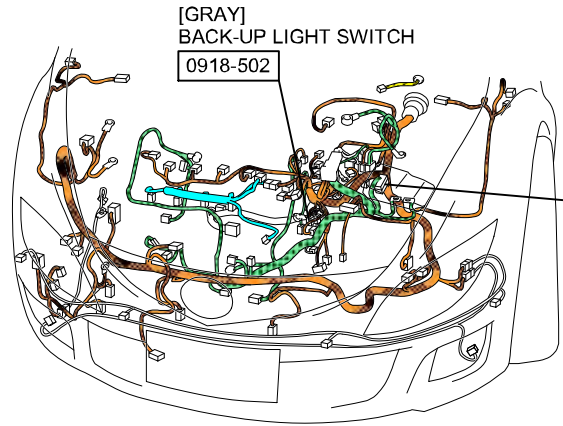



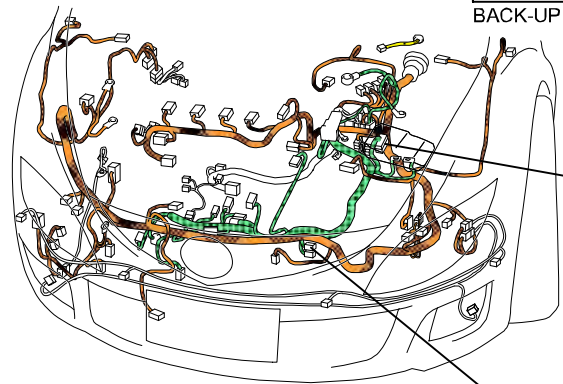







[EXCEPT MZR-CD (RF Turbo)]



[MZR-CD (RF Turbo)]

-  : FRONT HARNESS
-  : ENGINE HARNESS
-  : INJECTION HARNESS
-  : REAR HARNESS
-  : REAR NO.2 HARNESS
-  : REAR NO.3 HARNESS
-  : REAR NO.4 HARNESS
-  : DOOR HARNESS
-  : INTERIOR LIGHT HARNESS
-  : FLOOR HARNESS

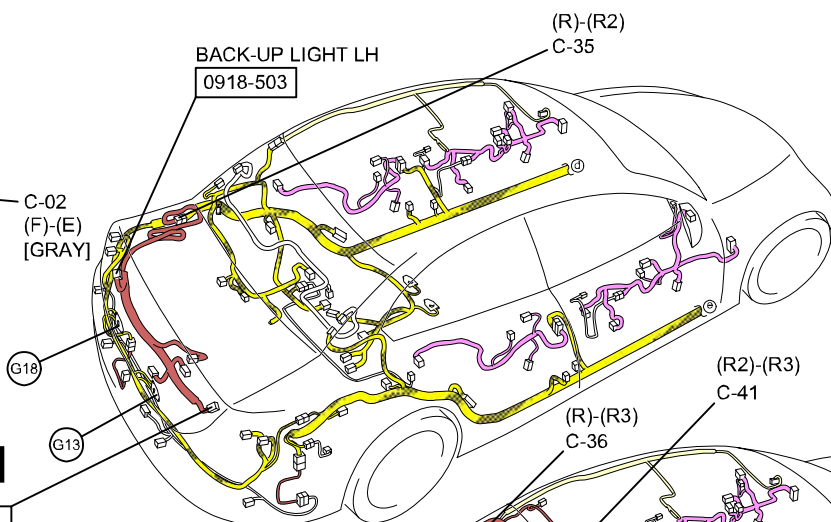

[4SD]

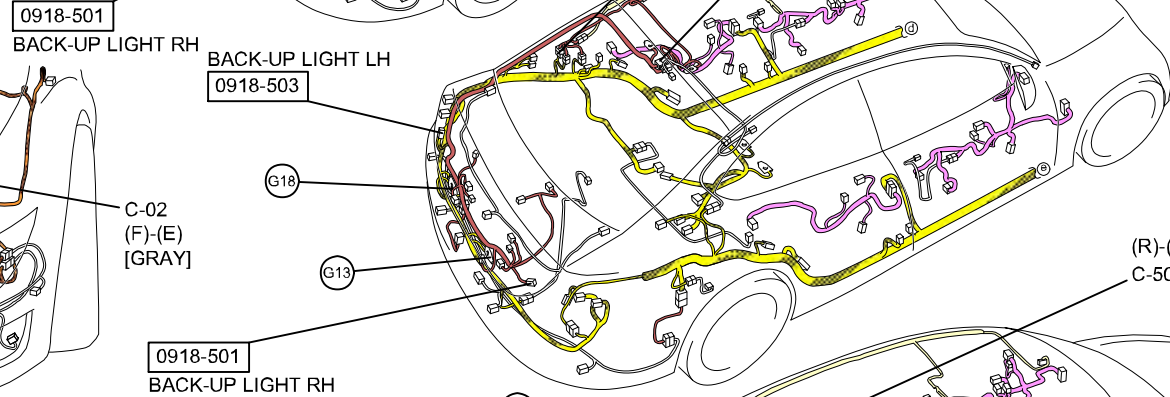

[5HB]

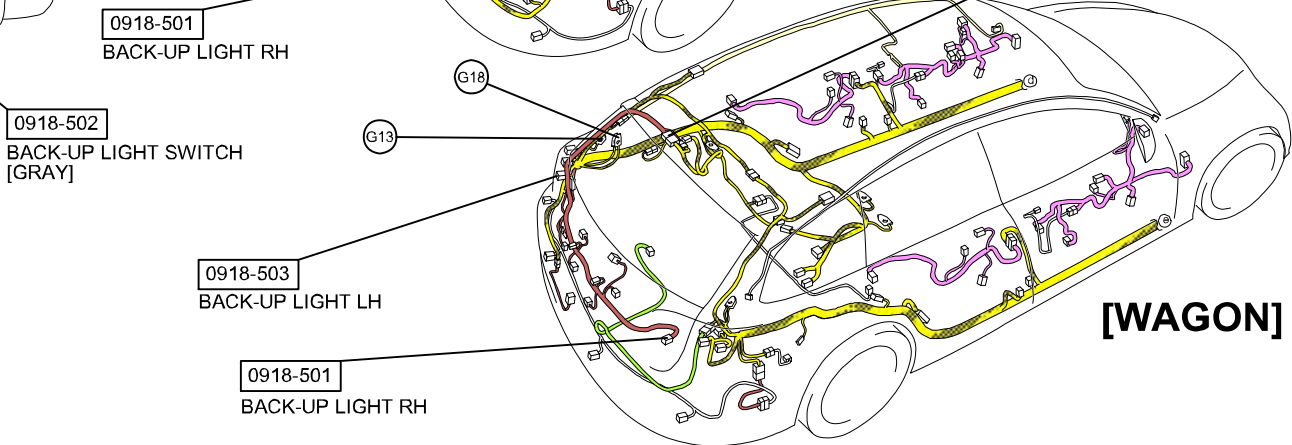

[WAGON]

C-02
FRONT HARNESS-ENGINE HARNESS

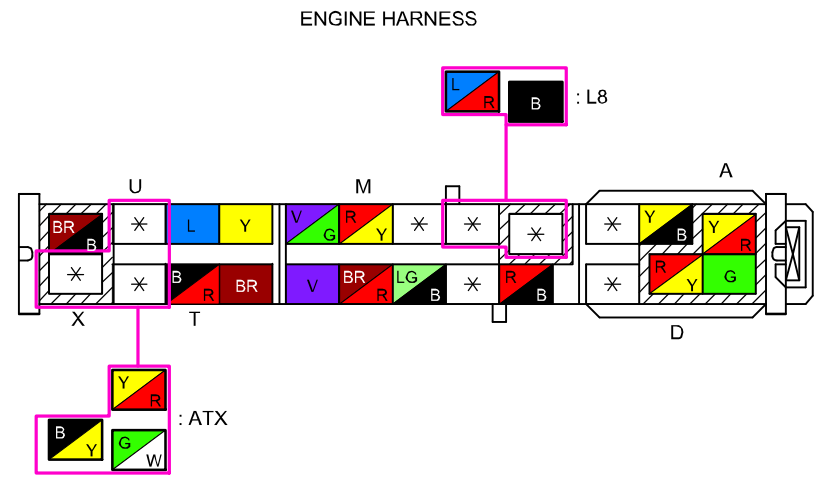
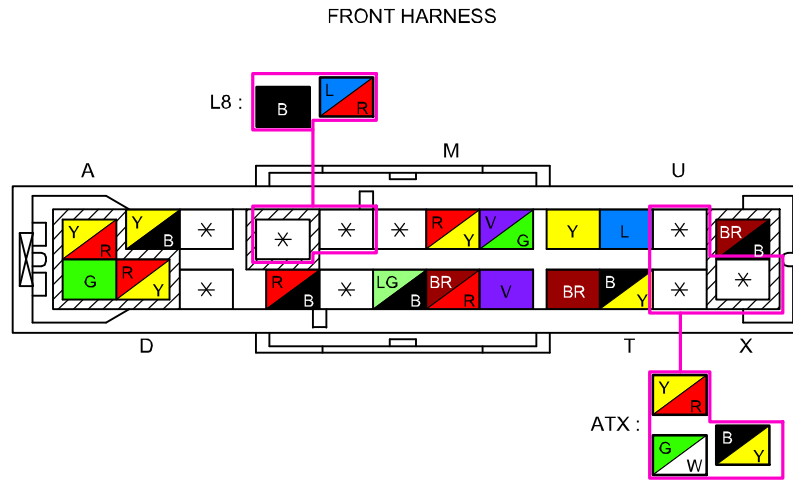

(EXCEPT MZR-CD (RF Turbo))

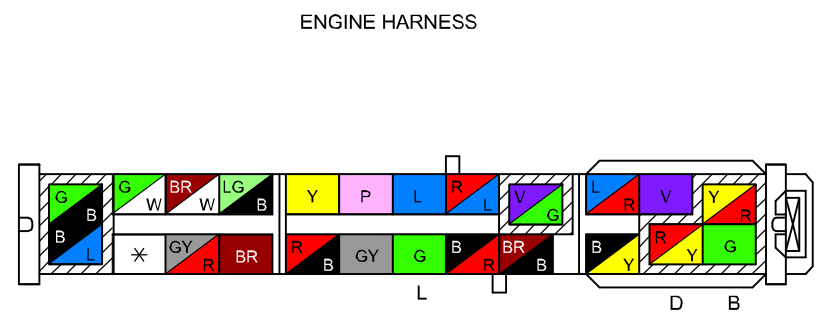
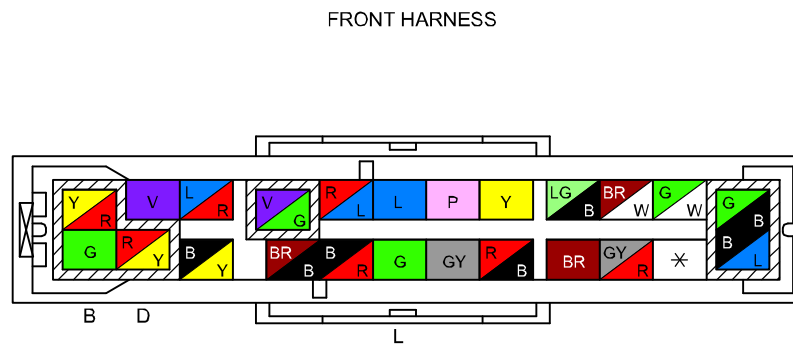

(MZR-CD (RF Turbo))

BACK-UP LIGHT

C-35
REAR HARNESS-REAR NO.2 HARNESS

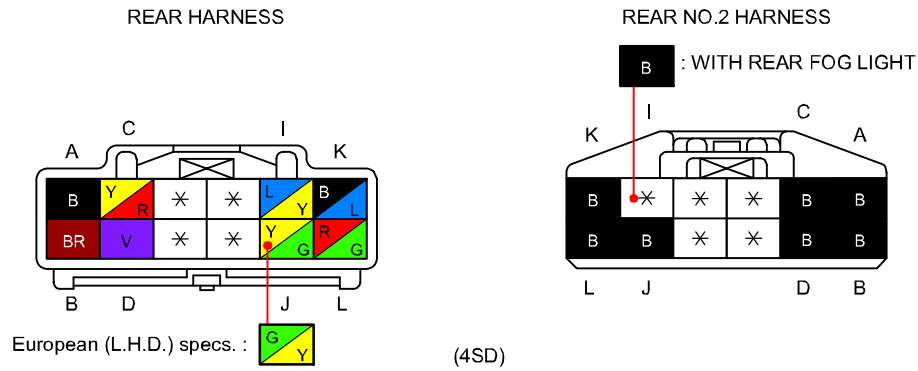

C-36
REAR HARNESS-REAR NO.3 HARNESS

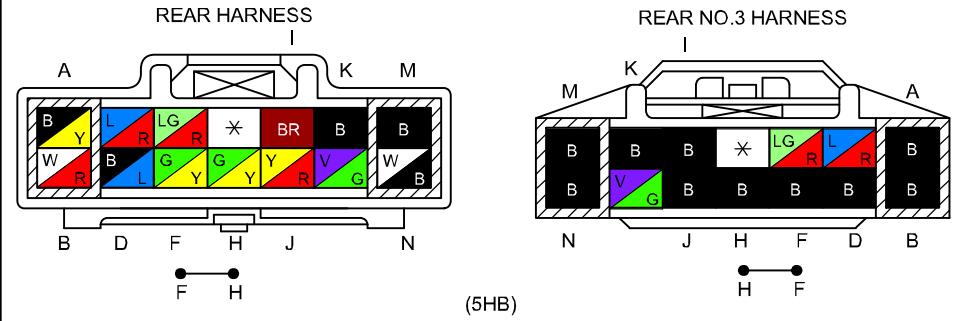

C-41
REAR NO.2 HARNESS-REAR NO.3 HARNESS

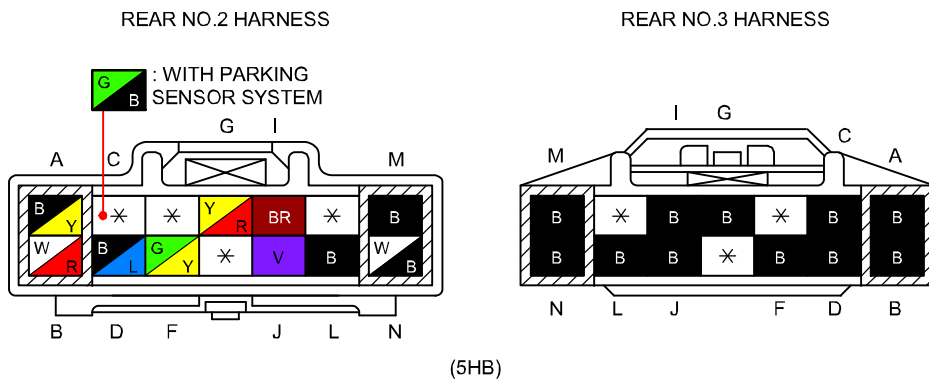

C-50
REAR HARNESS-REAR NO.2 HARNESS

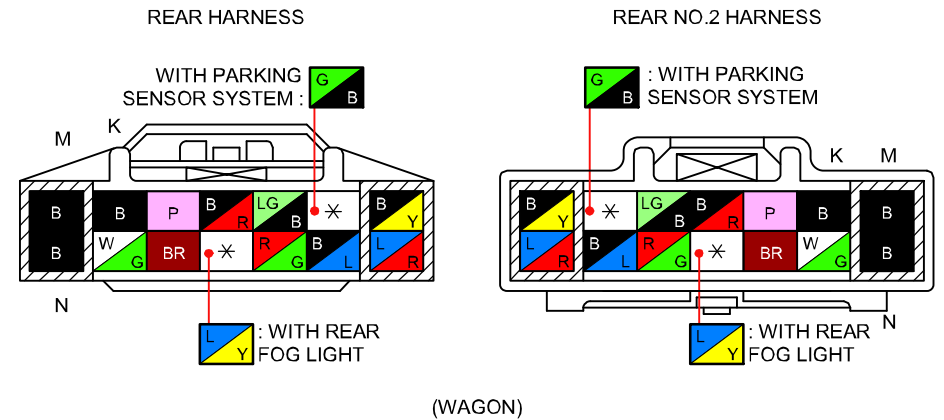



BRAKE LIGHT / HIGH-MOUNT BRAKE LIGHT

0918-6a

&5 : MZR-CD (RF Turbo)

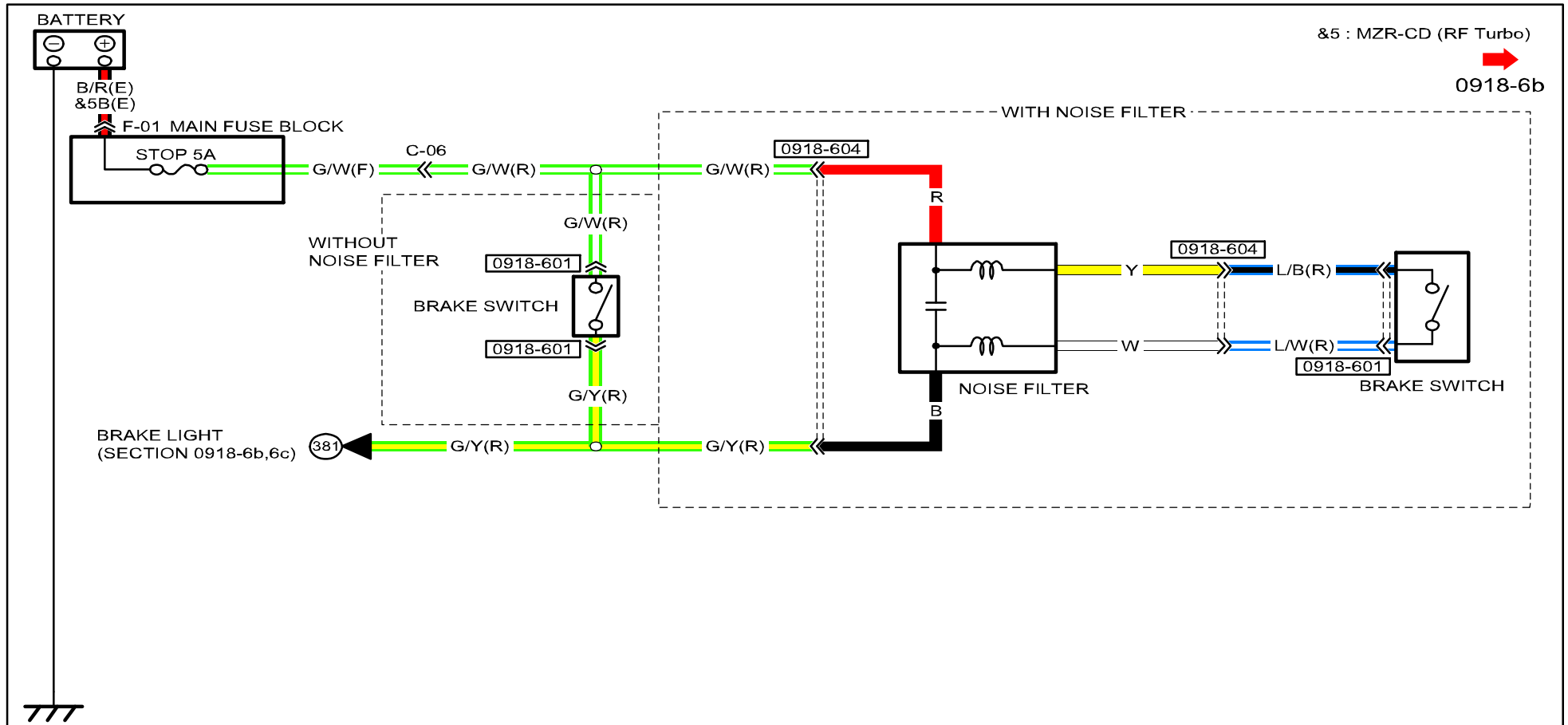
0918-6b

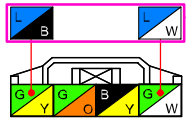

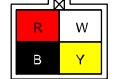
<p>0918-601 BRAKE SWITCH / BRAKE SWITCH2</p>  <p>: WITH NOISE FILTER</p>	<p>0918-604 REAR HARNESS-SHORT CORD</p> <p>REAR HARNESS</p>  <p>SHORT CORD</p> 			

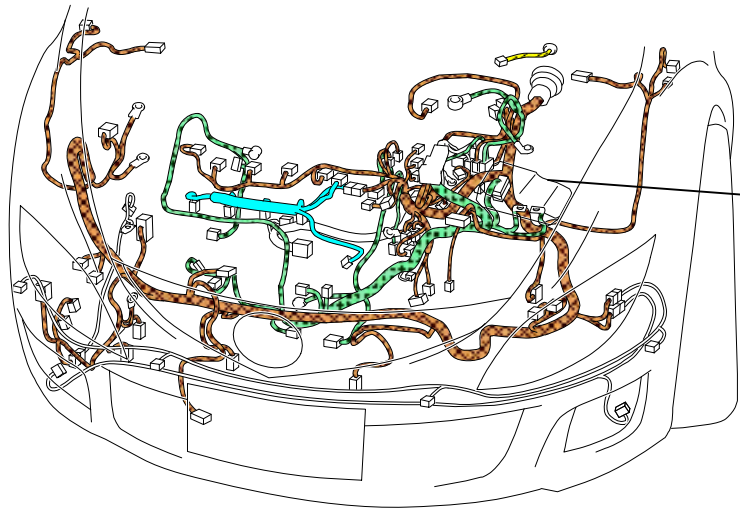

F-01
MAIN FUSE BLOCK
(REFER TO 00F
SECTION)

[EXCEPT MZR-CD (RF Turbo)]

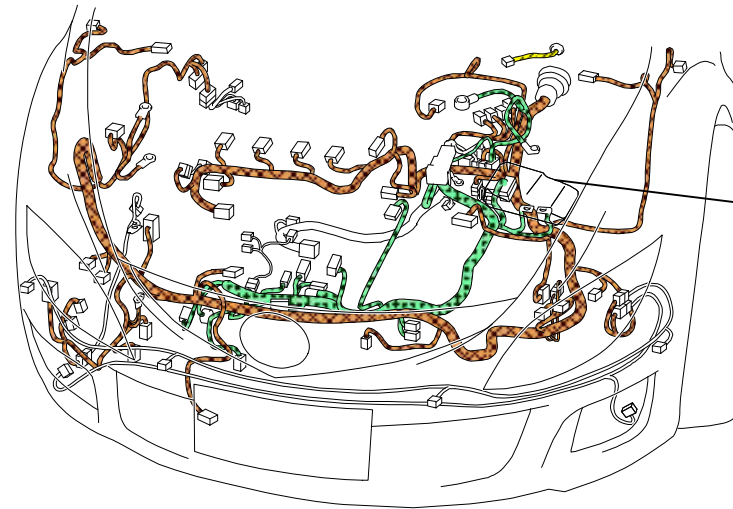

F-01
MAIN FUSE BLOCK
(REFER TO 00F
SECTION)



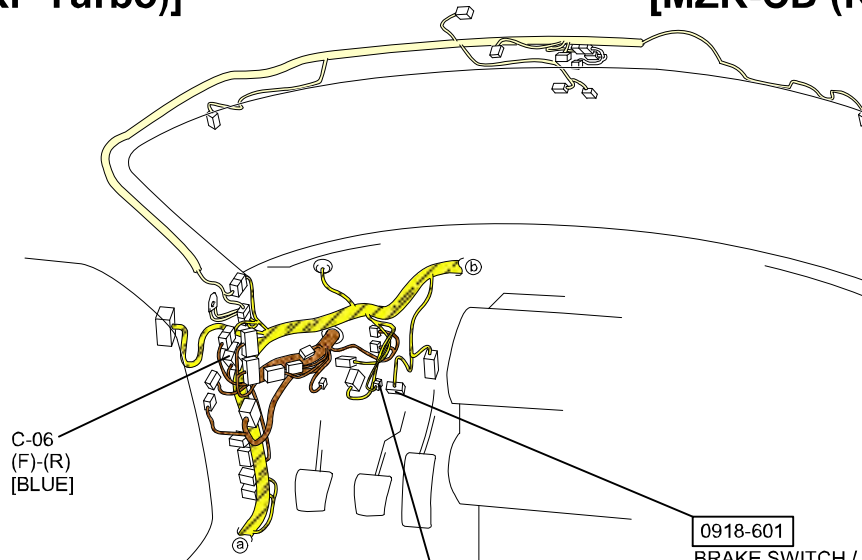

[MZR-CD (RF Turbo)]



C-06
(F)-(R)
[BLUE]

0918-604
(R)-SHORT CORD

0918-601
BRAKE SWITCH /
BRAKE SWITCH2

-  : FRONT HARNESS
-  : ENGINE HARNESS
-  : INJECTION HARNESS
-  : REAR HARNESS
-  : INTERIOR LIGHT NO.2 HARNESS

BRAKE LIGHT / HIGH-MOUNT BRAKE LIGHT

0918-6a

C-06

FRONT HARNESS-REAR HARNESS





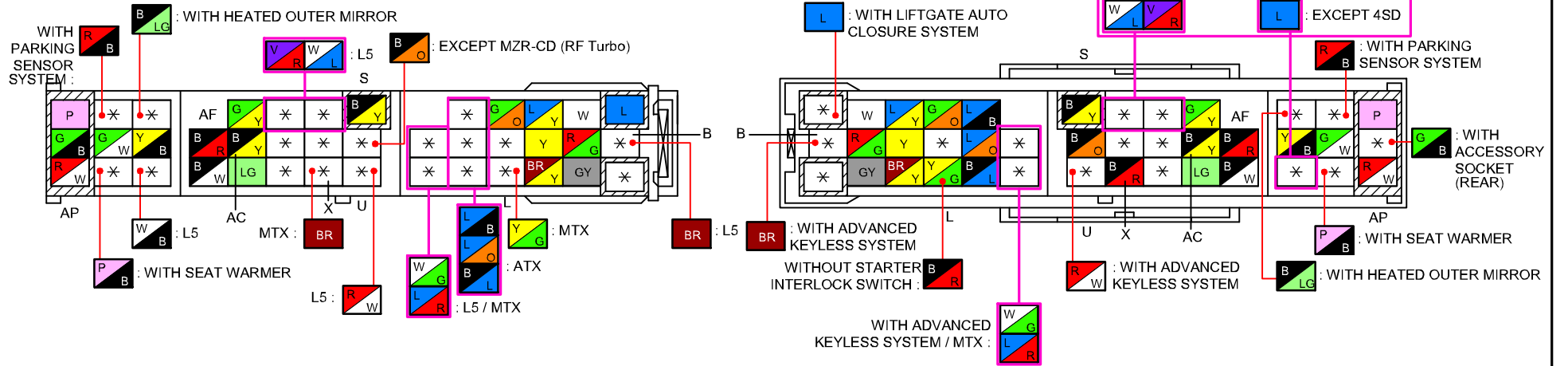



FRONT HARNESS

REAR HARNESS



BRAKE LIGHT / HIGH-MOUNT BRAKE LIGHT

0918-6b

-  : FRONT HARNESS
-  : REAR HARNESS
-  : REAR NO.2 HARNESS
-  : REAR NO.3 HARNESS
-  : REAR NO.4 HARNESS
-  : DOOR HARNESS
-  : INTERIOR LIGHT HARNESS
-  : INTERIOR LIGHT NO.2 HARNESS

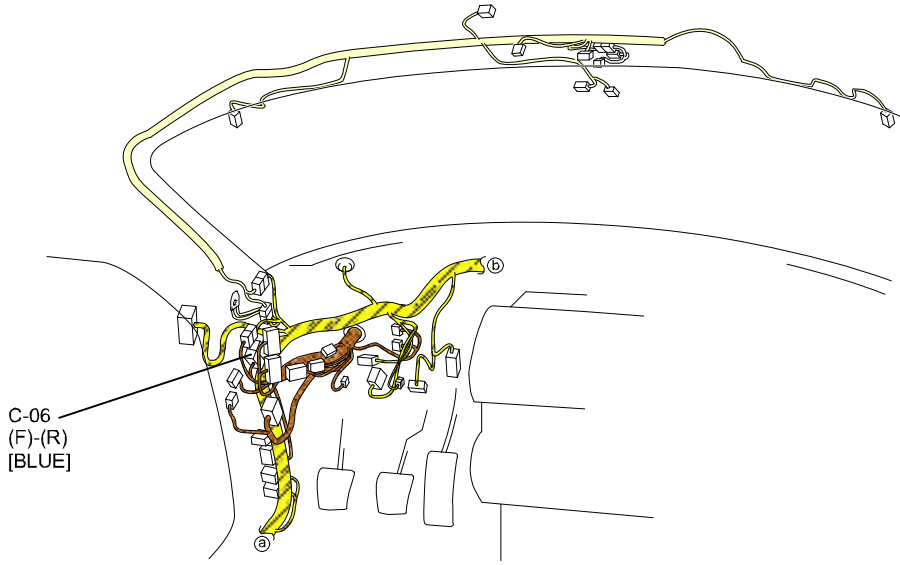

TAILLIGHT LH /
BRAKE LIGHT LH
0918-202

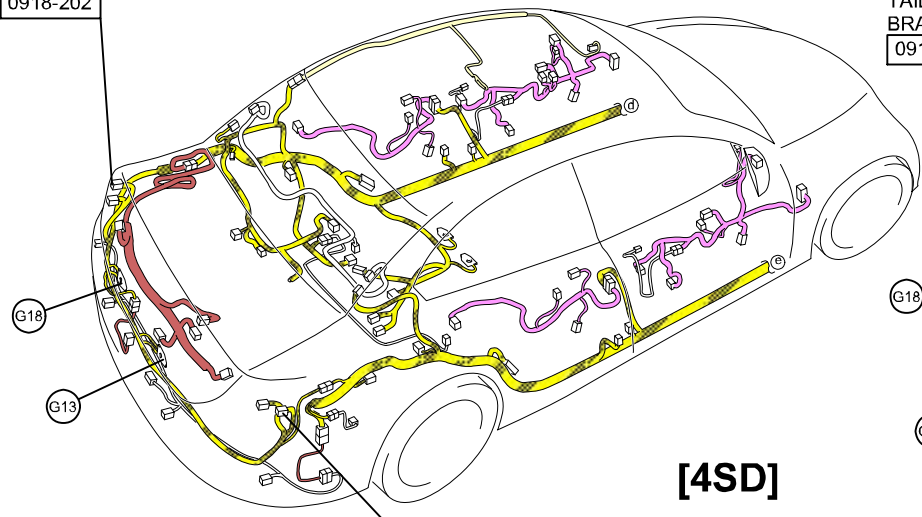

[4SD]

0918-203
TAILLIGHT RH /
BRAKE LIGHT RH

TAILLIGHT LH /
BRAKE LIGHT LH
0918-202

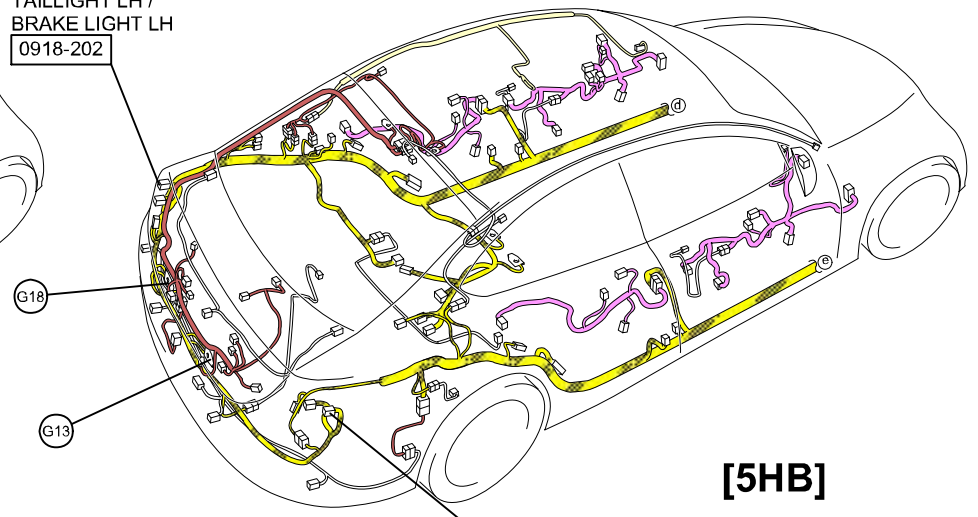

[5HB]

0918-203
TAILLIGHT RH /
BRAKE LIGHT RH

BRAKE LIGHT / HIGH-MOUNT BRAKE LIGHT

0918-6c

0918-6b

@2 : WITH ADVANCED KEYLESS SYSTEM
 @3 : WITHOUT DSC
 @4 : WITH DSC

0918-6d

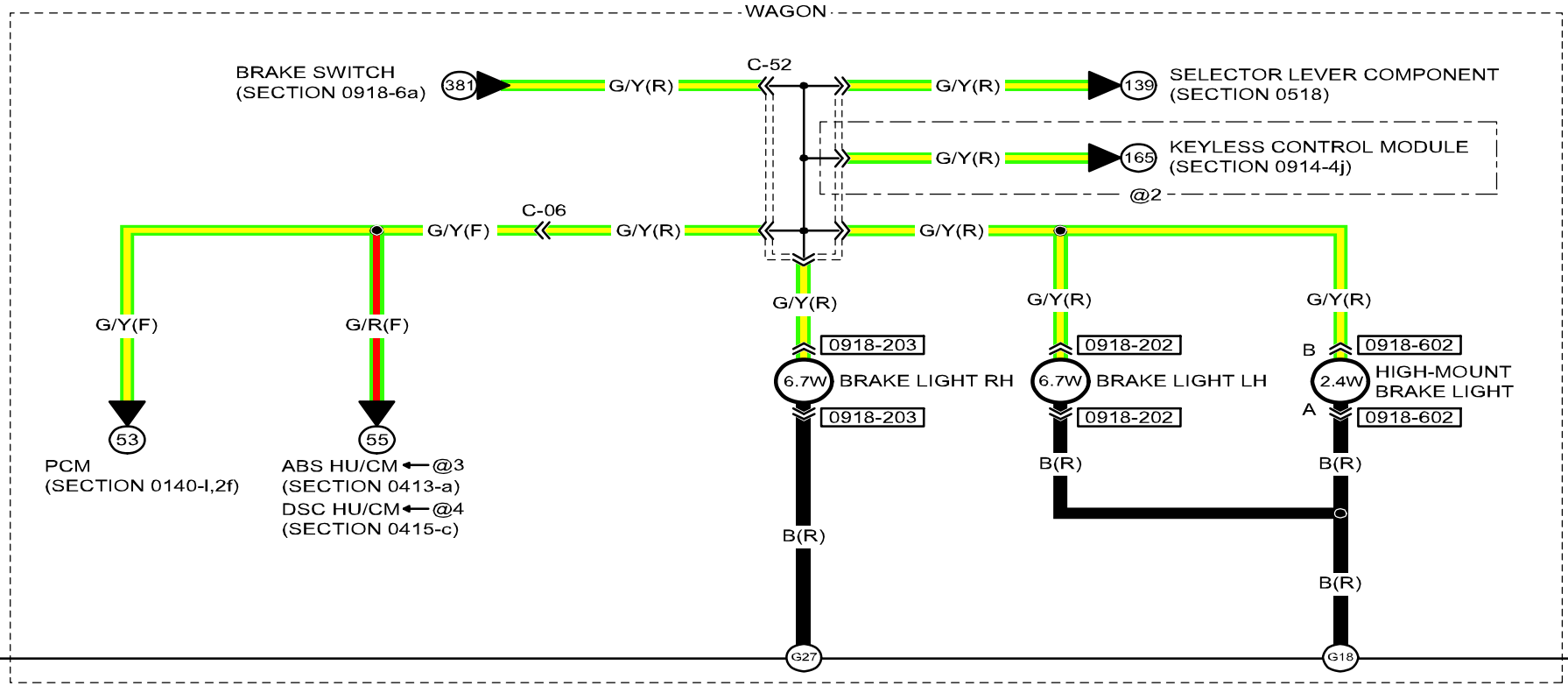

<p>0918-602 HIGH-MOUNT BRAKE LIGHT</p>	<p>0918-202 TAILLIGHT LH / BRAKE LIGHT LH</p> <p>4SD / General (L.H.D.) specs. :</p>	<p>0918-203 TAILLIGHT RH / BRAKE LIGHT RH</p>	

BRAKE LIGHT / HIGH-MOUNT BRAKE LIGHT

0918-6c

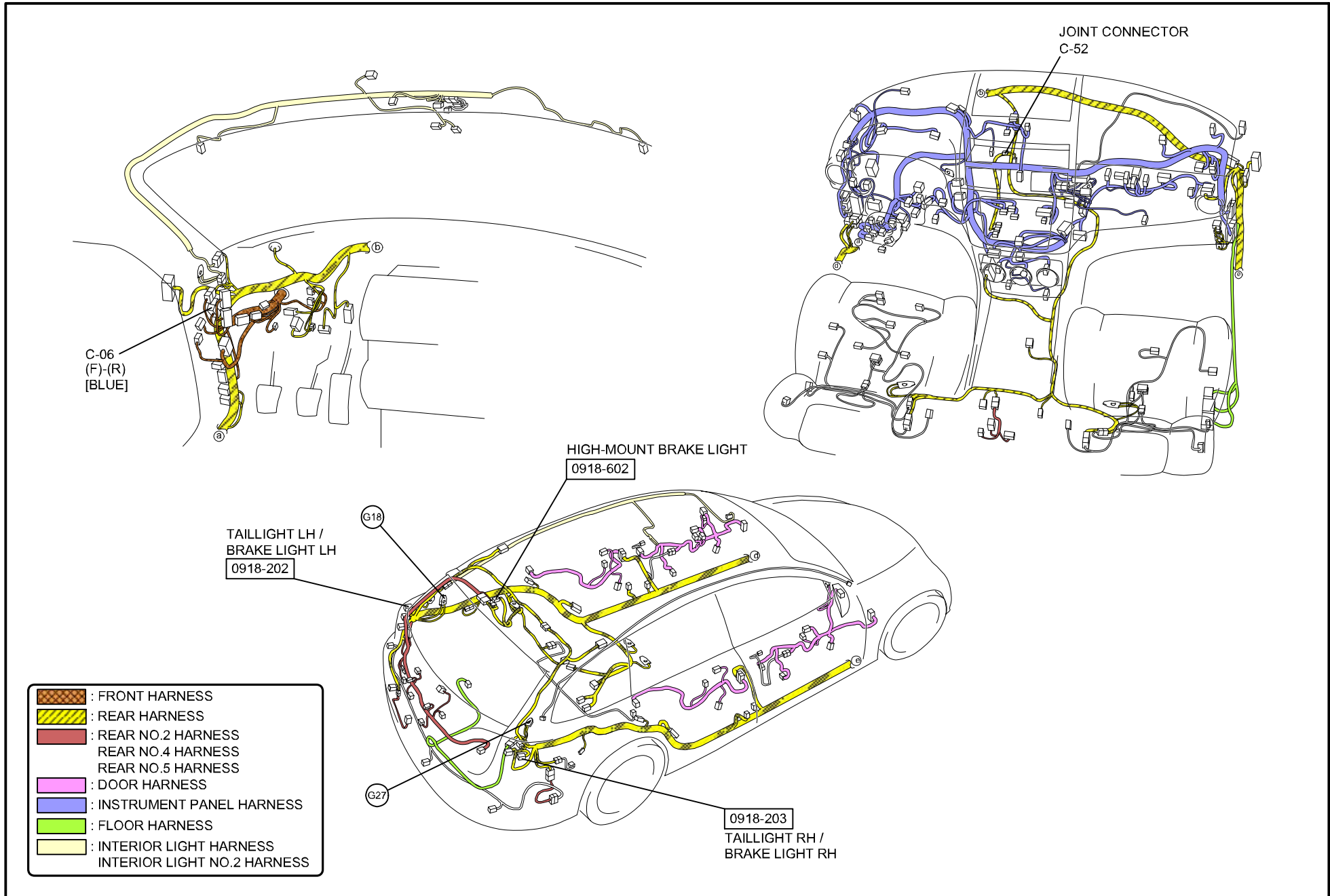

BRAKE LIGHT / HIGH-MOUNT BRAKE LIGHT

0918-6c

C-06

FRONT HARNESS-REAR HARNESS

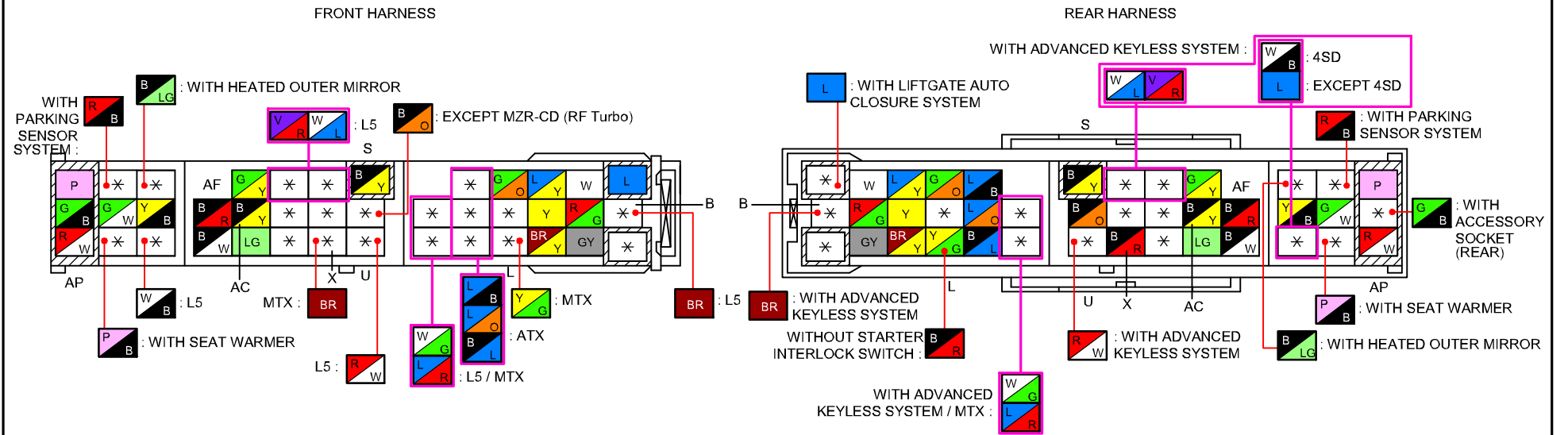

C-52

JOINT CONNECTOR

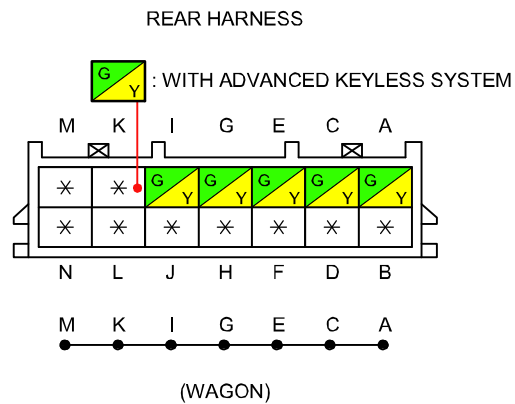



BRAKE LIGHT / HIGH-MOUNT BRAKE LIGHT

0918-6d

0918-6c

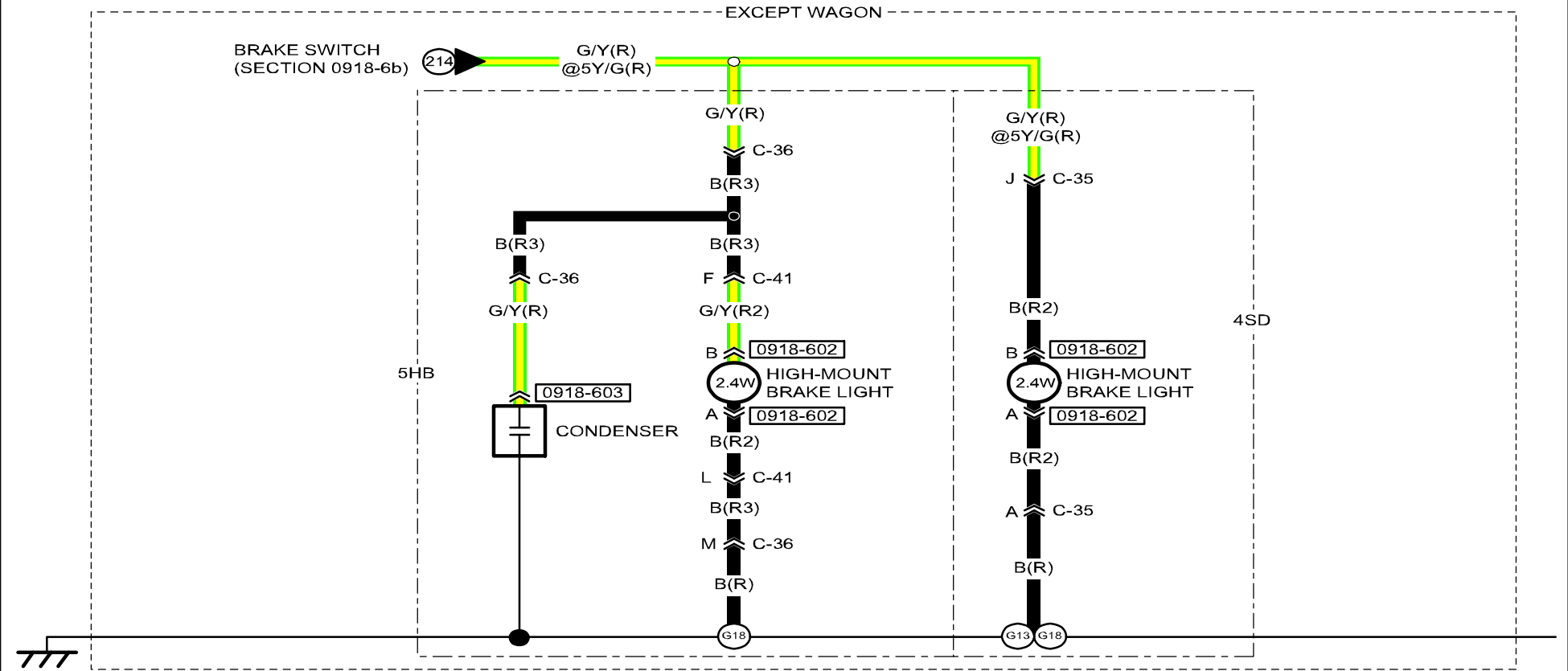
@5 : 4SD / General (L.H.D.) specs.

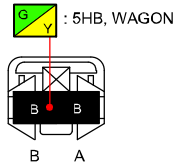

<p>0918-602 HIGH-MOUNT BRAKE LIGHT</p>  <p>G/Y : 5HB, WAGON</p>	<p>0918-603 CONDENSER</p> 				

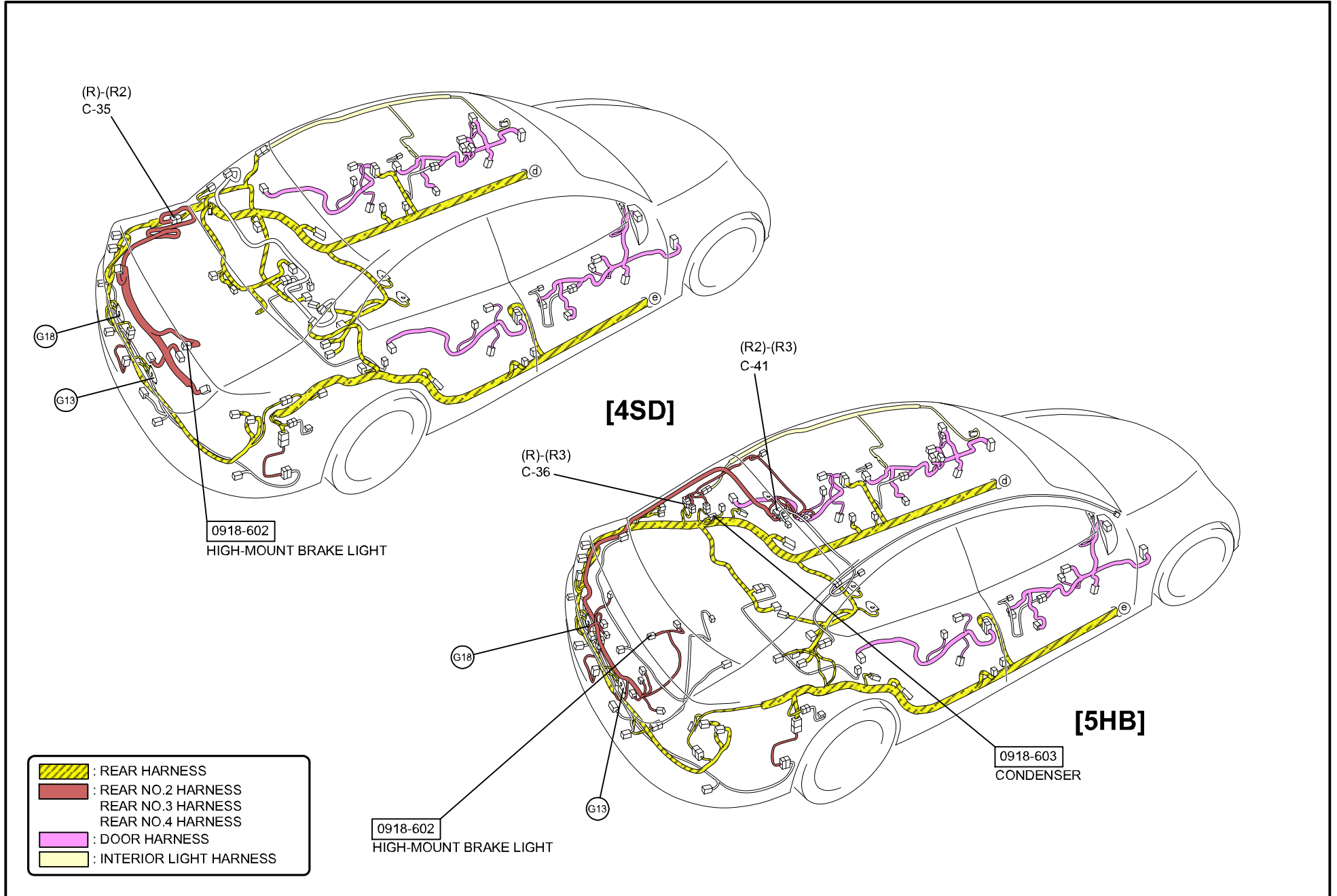

BRAKE LIGHT / HIGH-MOUNT BRAKE LIGHT

C-35
REAR HARNESS-REAR NO.2 HARNESS

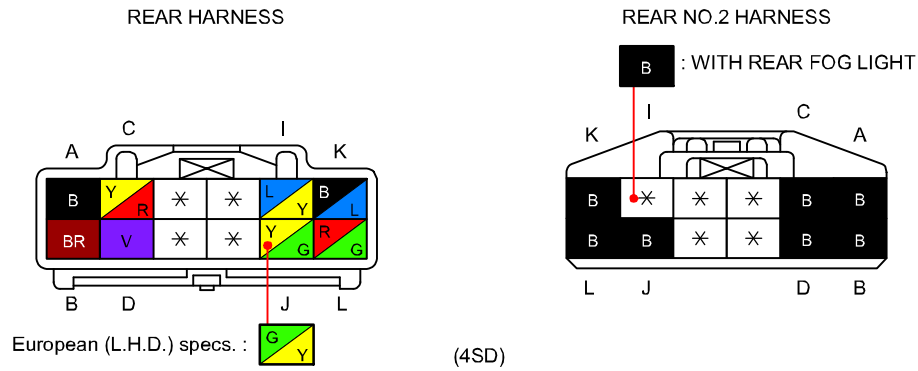

C-36
REAR HARNESS-REAR NO.3 HARNESS

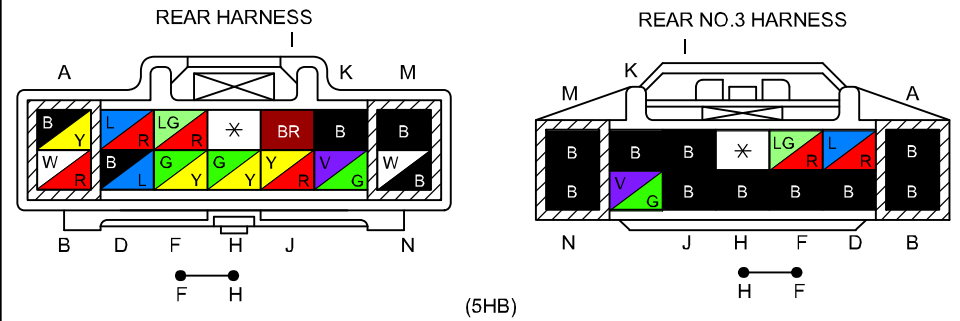

C-41
REAR NO.2 HARNESS-REAR NO.3 HARNESS

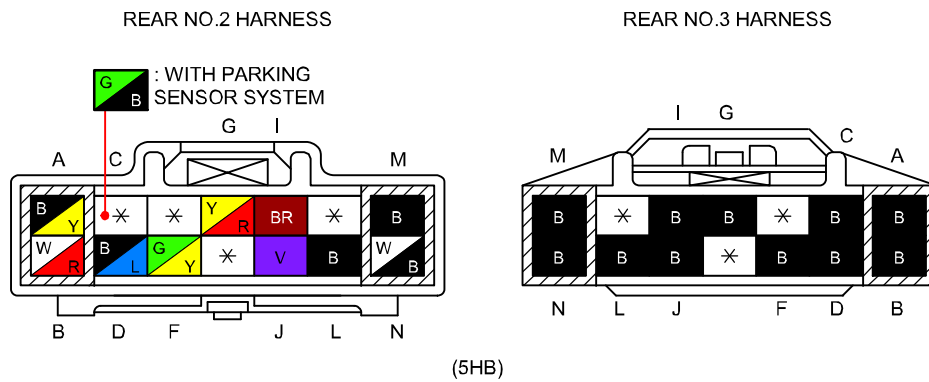

[] : 5HB

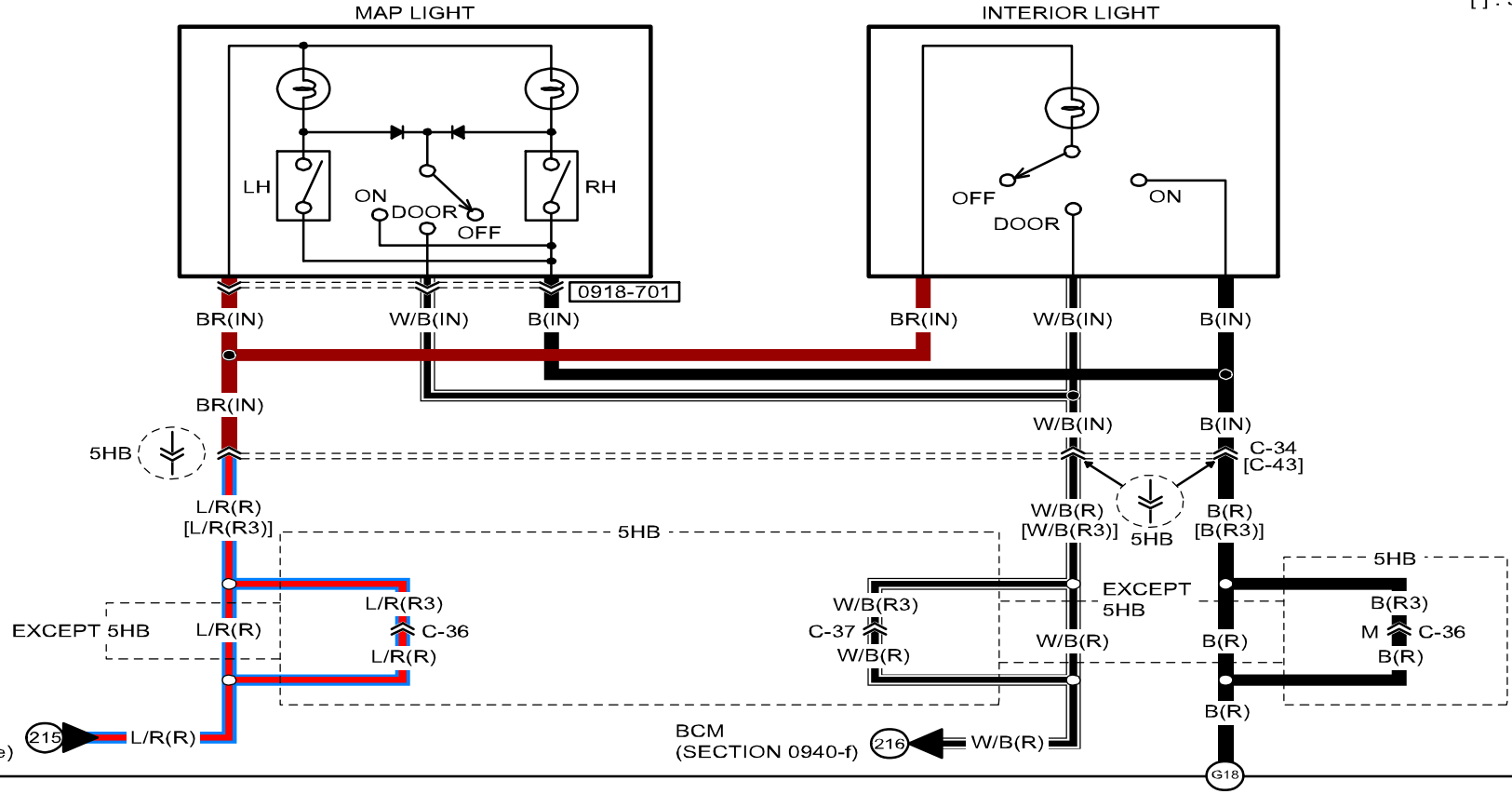

0918-701
MAP LIGHT /
DOWN LIGHT

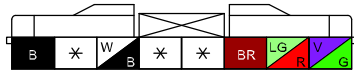

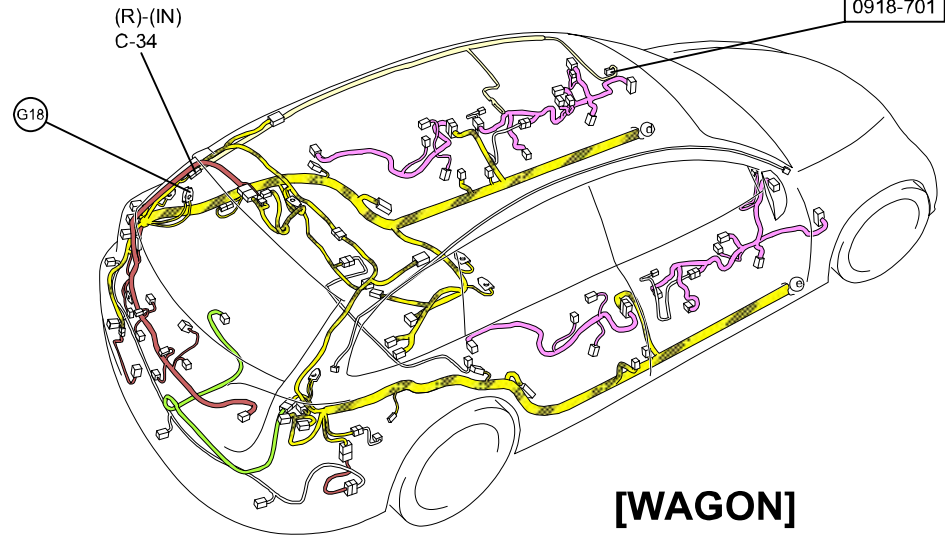
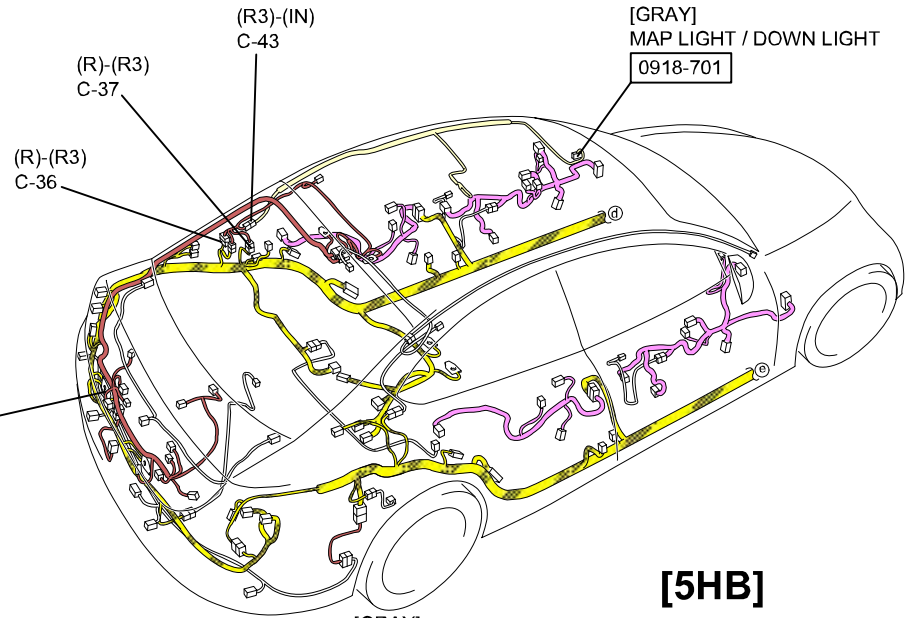
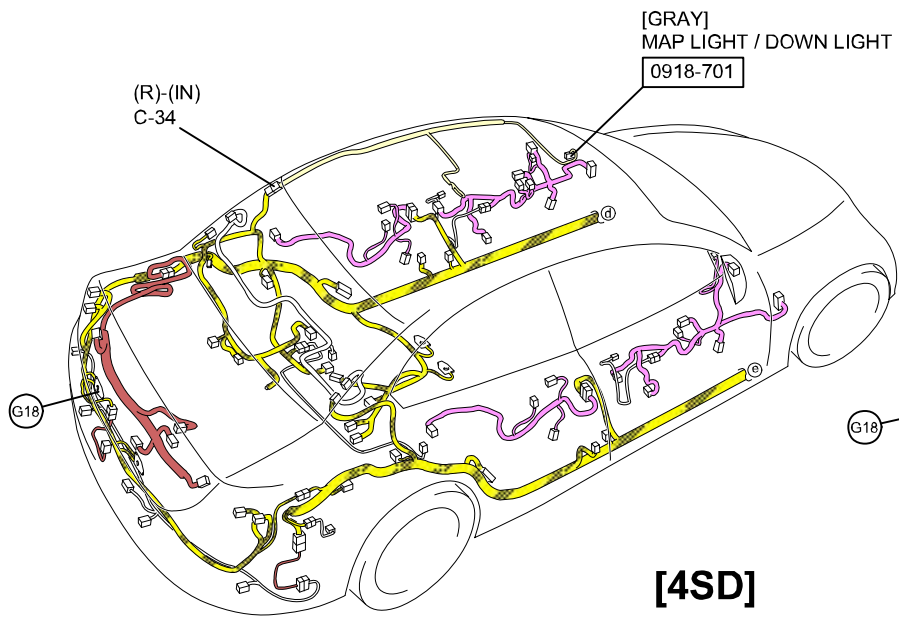

- : REAR HARNESS
- : REAR NO.2 HARNESS
REAR NO.3 HARNESS
REAR NO.4 HARNESS
- : DOOR HARNESS
- : INTERIOR LIGHT HARNESS
- : FLOOR HARNESS

C-34
REAR HARNESS-INTERIOR LIGHT HARNESS

REAR HARNESS

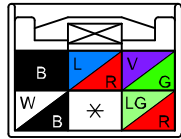

INTERIOR LIGHT HARNESS

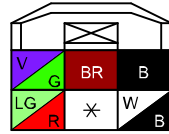

(EXCEPT 5HB)

C-36
REAR HARNESS-REAR NO.3 HARNESS

REAR HARNESS

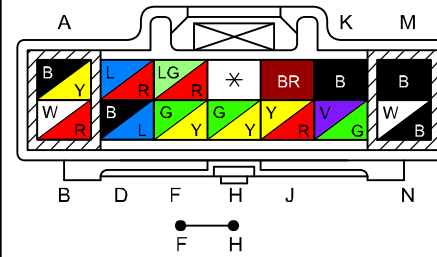

REAR NO.3 HARNESS

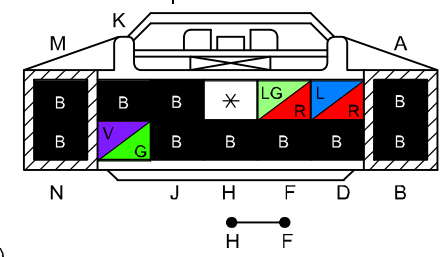

(5HB)

C-37
REAR HARNESS-REAR NO.3 HARNESS

REAR HARNESS

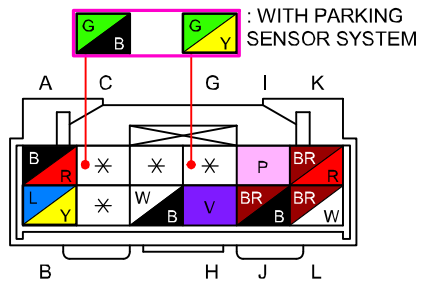

: WITH PARKING SENSOR SYSTEM

REAR NO.3 HARNESS

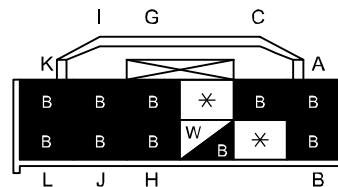

(5HB)

C-43
REAR NO.3 HARNESS-INTERIOR LIGHT HARNESS

REAR NO.3 HARNESS

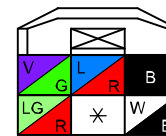

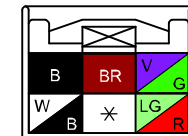

INTERIOR LIGHT HARNESS

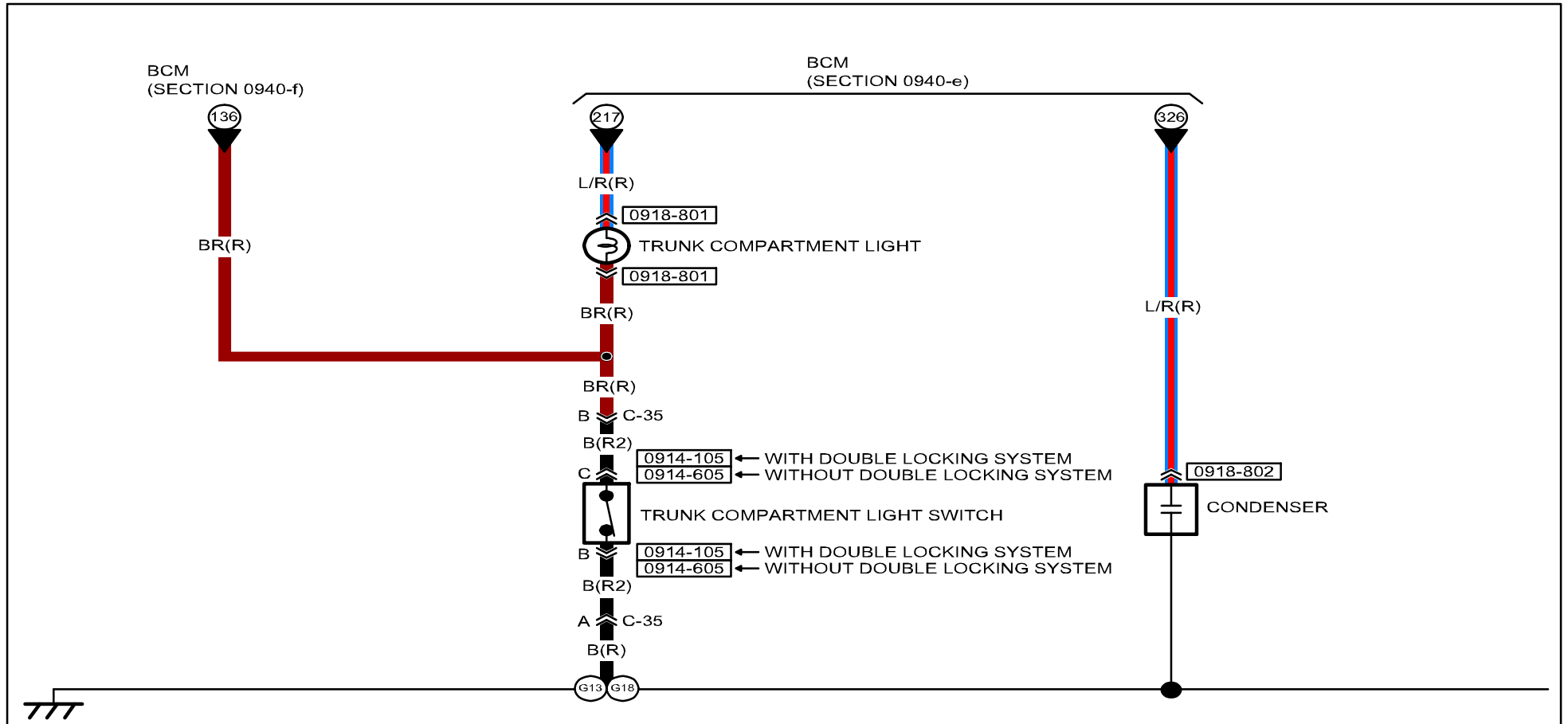

(5HB)

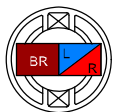

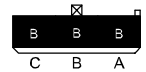
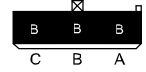
<p>0918-801 TRUNK COMPARTMENT LIGHT</p> 	<p>0918-802 CONDENSER</p> 	<p>0914-105 TRUNK LID OPENER / TRUNK COMPARTMENT LIGHT SWITCH</p> 	<p>0914-605 TRUNK LID OPENER / TRUNK COMPARTMENT LIGHT SWITCH</p> 		

TRUNK COMPARTMENT LIGHT

0918-8

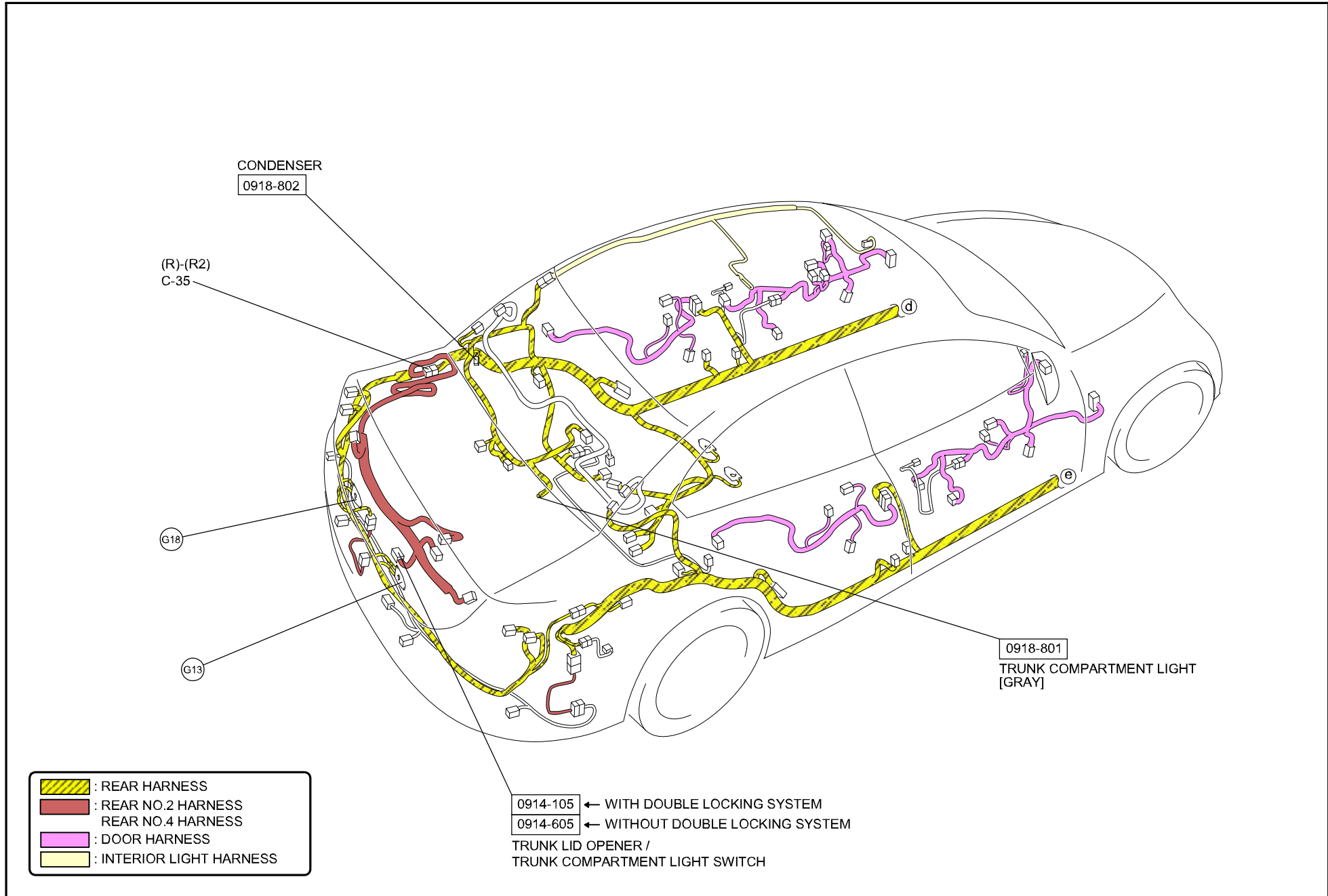

C-35
 REAR HARNESS-REAR NO.2 HARNESS

REAR HARNESS

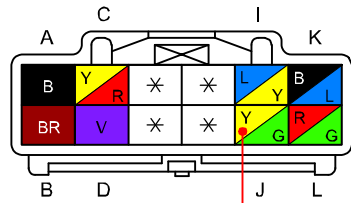

European (L.H.D.) specs. :



(4SD)

REAR NO.2 HARNESS

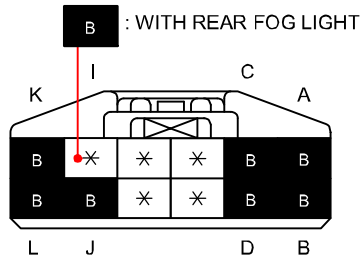

B : WITH REAR FOG LIGHT

CARGO COMPARTMENT LIGHT

0918-9

#9 : WITH DOUBLE LOCKING SYSTEM
#8 : WITHOUT DOUBLE LOCKING SYSTEM

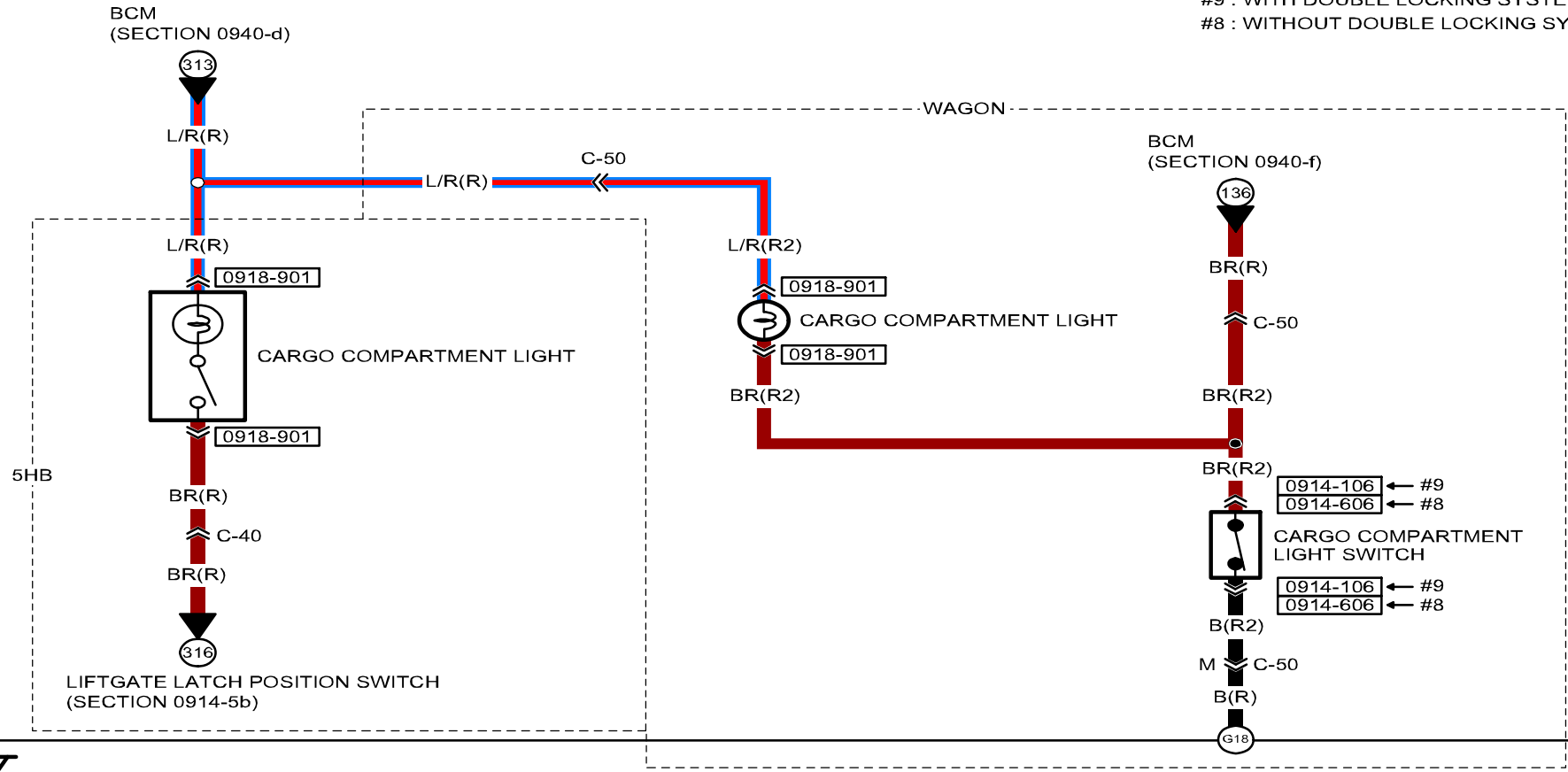

0918-901
CARGO COMPARTMENT LIGHT

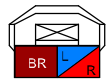

(5HB)

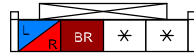

(WAGON)

0914-106
LIFTGATE LOCK ACTUATOR /
CARGO COMPARTMENT LIGHT SWITCH



0914-606
LIFTGATE LOCK ACTUATOR /
CARGO COMPARTMENT LIGHT SWITCH



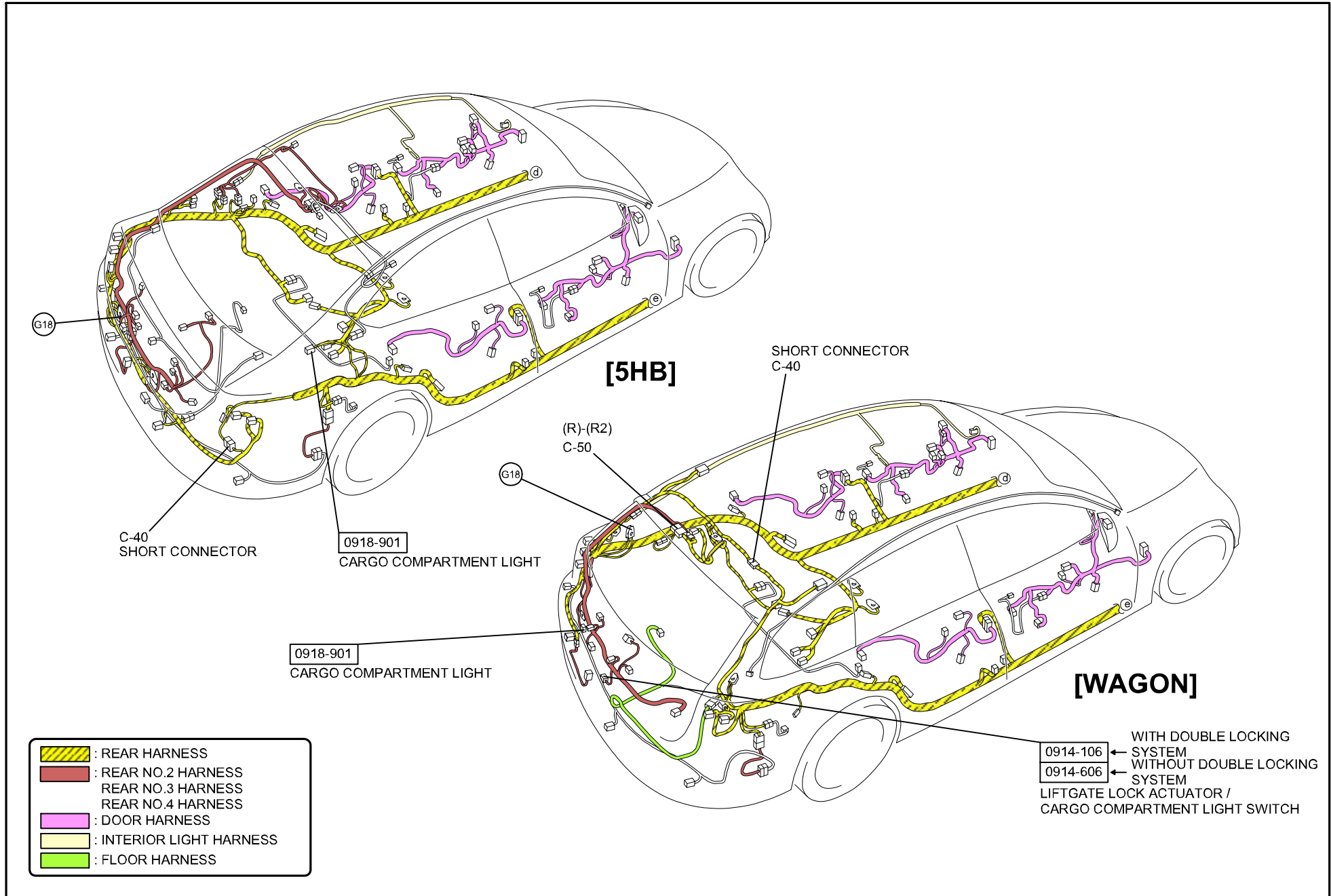

- : REAR HARNESS
- : REAR NO.2 HARNESS
REAR NO.3 HARNESS
REAR NO.4 HARNESS
- : DOOR HARNESS
- : INTERIOR LIGHT HARNESS
- : FLOOR HARNESS

- ← WITH DOUBLE LOCKING
- ← 0914-106 SYSTEM
- ← 0914-606 SYSTEM
- ← LIFTGATE LOCK ACTUATOR / CARGO COMPARTMENT LIGHT SWITCH

CARGO COMPARTMENT LIGHT

0918-9

C-40 SHORT CONNECTOR

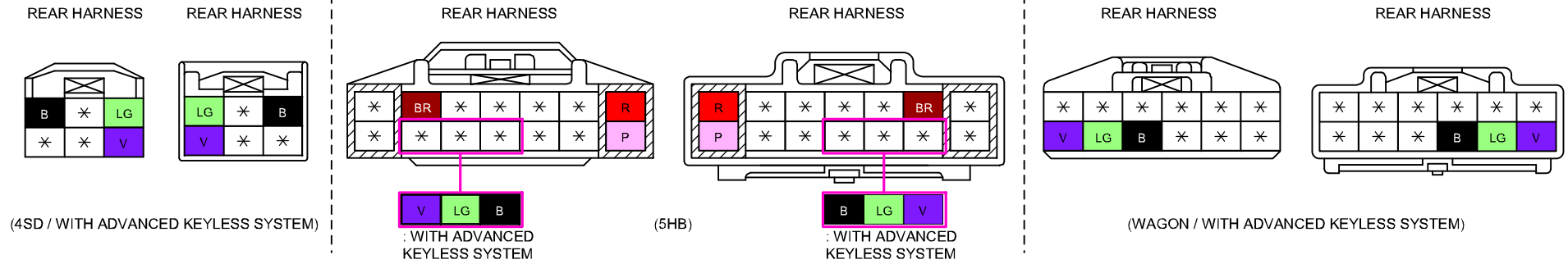

C-50 REAR HARNESS-REAR NO.2 HARNESS

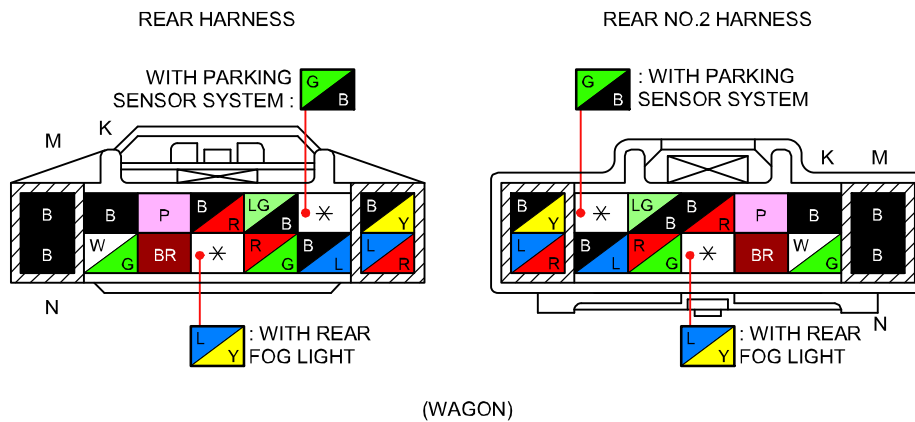

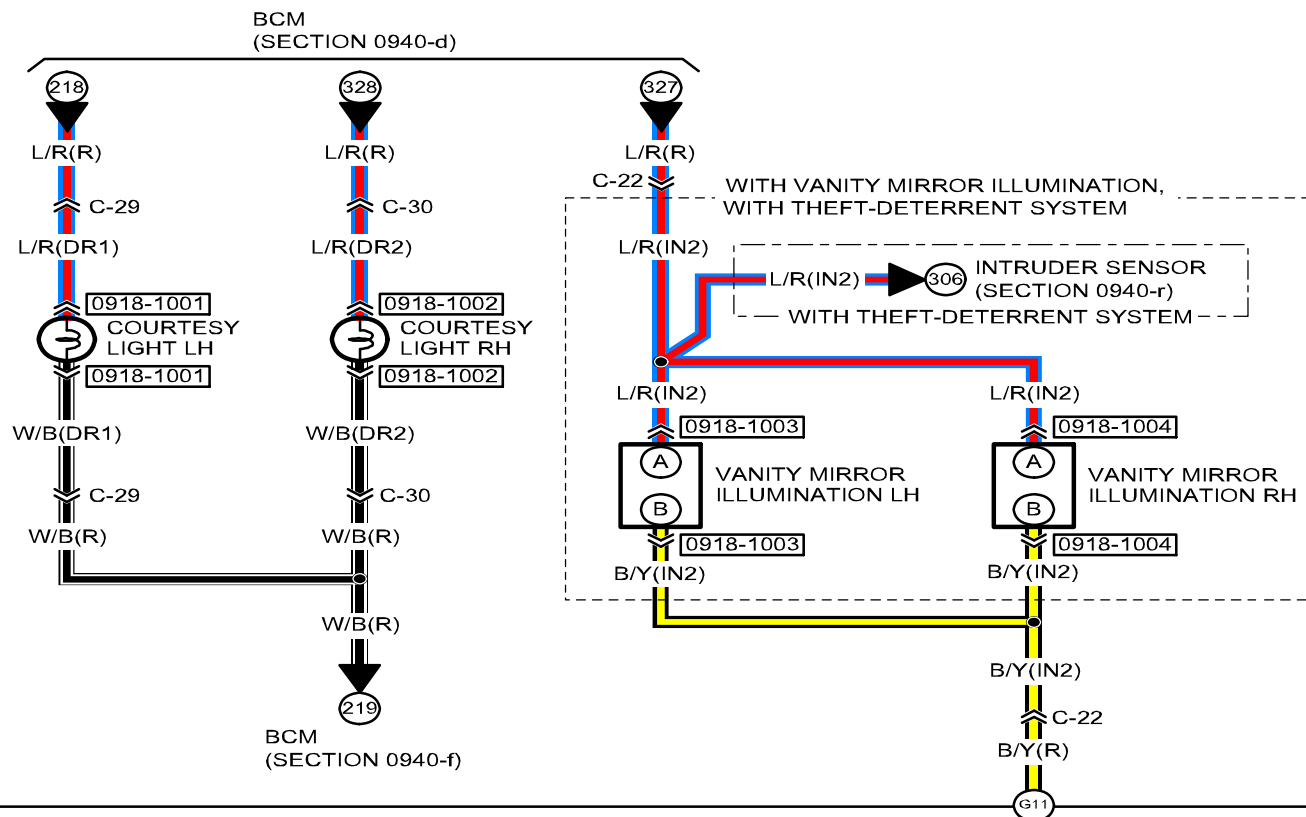

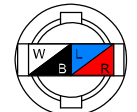
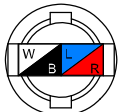
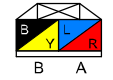
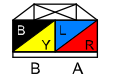
<p>0918-1001 COURTESY LIGHT LH</p> 	<p>0918-1002 COURTESY LIGHT RH</p> 	<p>0918-1003 VANITY MIRROR ILLUMINATION LH</p> 	<p>0918-1004 VANITY MIRROR ILLUMINATION RH</p> 	

COURTESY LIGHT / VANITY MIRROR ILLUMINATION

0918-10

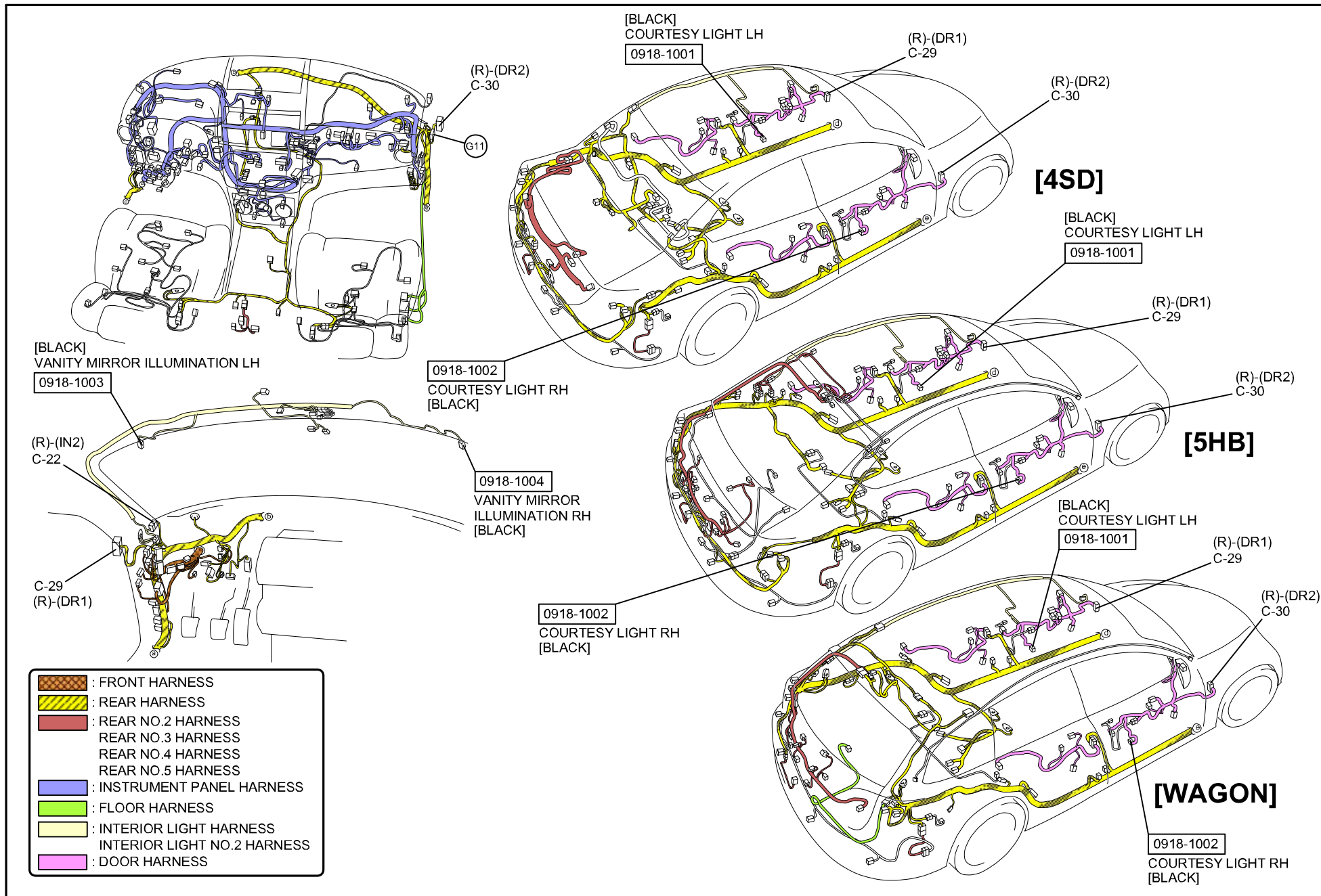

C-22

REAR HARNESS-INTERIOR LIGHT NO.2 HARNESS

REAR HARNESS

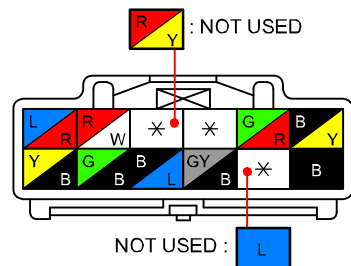

INTERIOR LIGHT NO.2 HARNESS

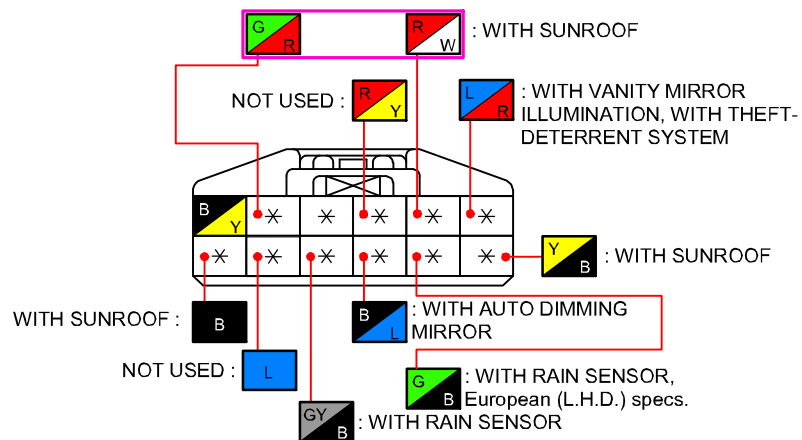

C-29

REAR HARNESS-DOOR NO.1 HARNESS

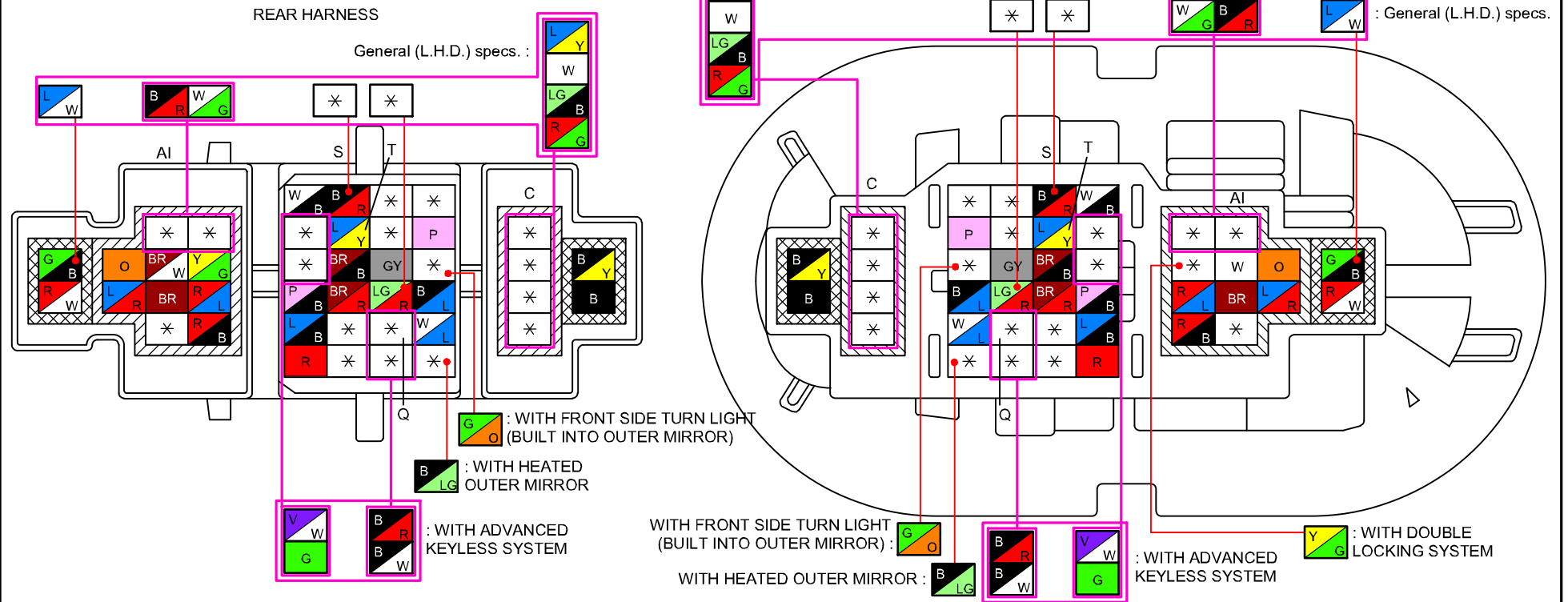

C-30

REAR HARNESS-DOOR NO.2 HARNESS

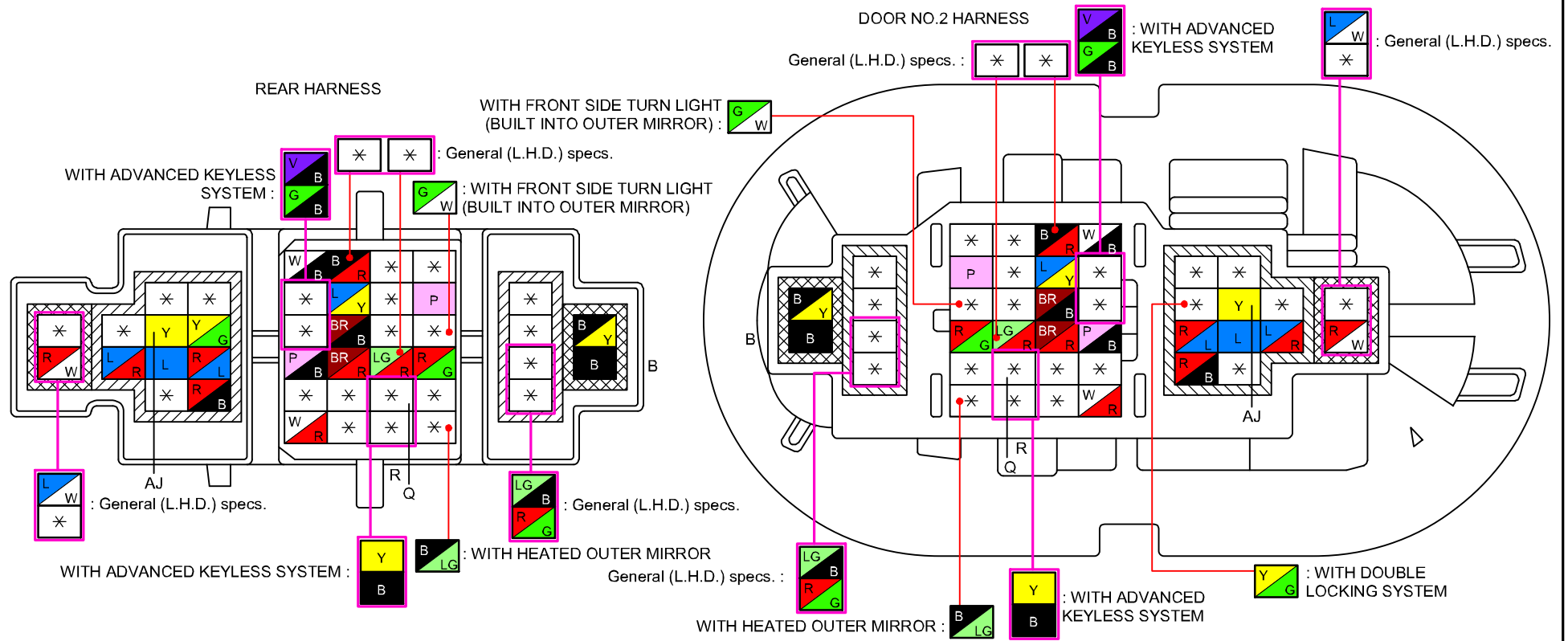

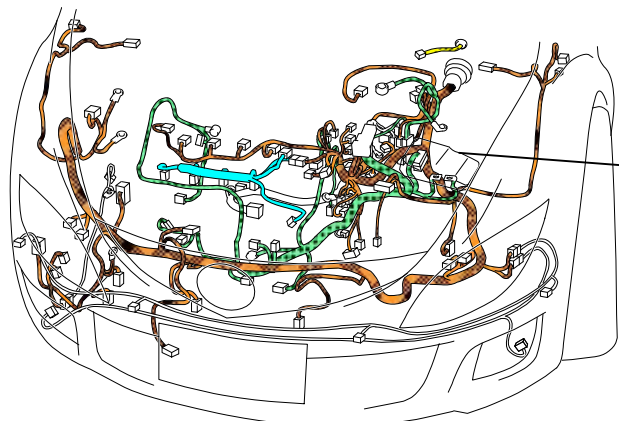

F-01
MAIN FUSE BLOCK
(REFER TO 00F SECTION)

[EXCEPT MZR-CD (RF Turbo)]

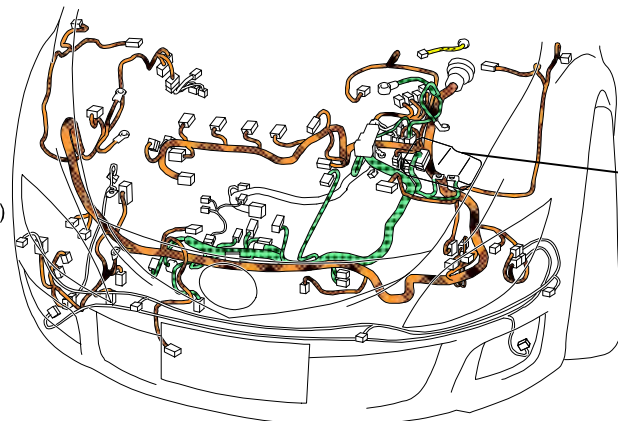

F-01
MAIN FUSE BLOCK
(REFER TO 00F SECTION)

[MZR-CD (RF Turbo)]

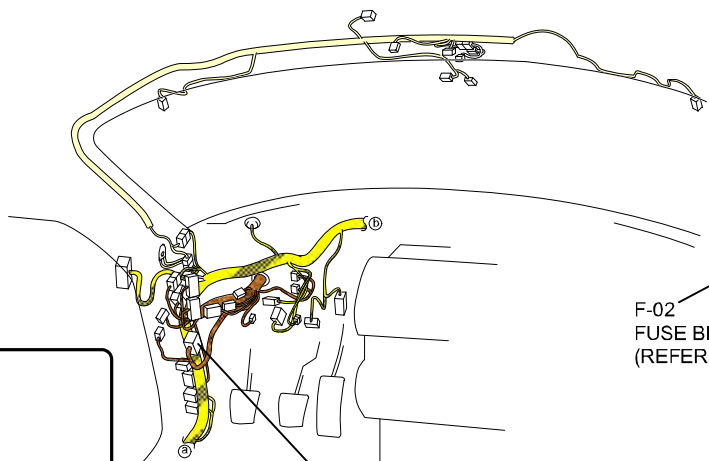



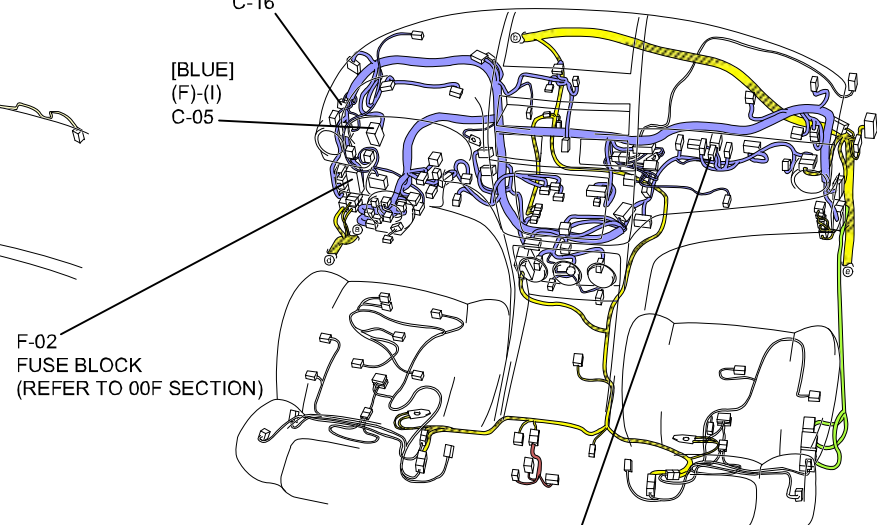





C-05
(F)-(I)
[BLUE]



F-02
FUSE BLOCK
(REFER TO 00F SECTION)

0918-1101
AFS CONTROL MODULE

-  : FRONT HARNESS
-  : ENGINE HARNESS
-  : INJECTION HARNESS
-  : REAR HARNESS
-  : REAR NO.5 HARNESS
-  : INSTRUMENT PANEL HARNESS
-  : FLOOR HARNESS
-  : INTERIOR LIGHT NO.2 HARNESS

C-05

FRONT HARNESS-INSTRUMENT PANEL HARNESS

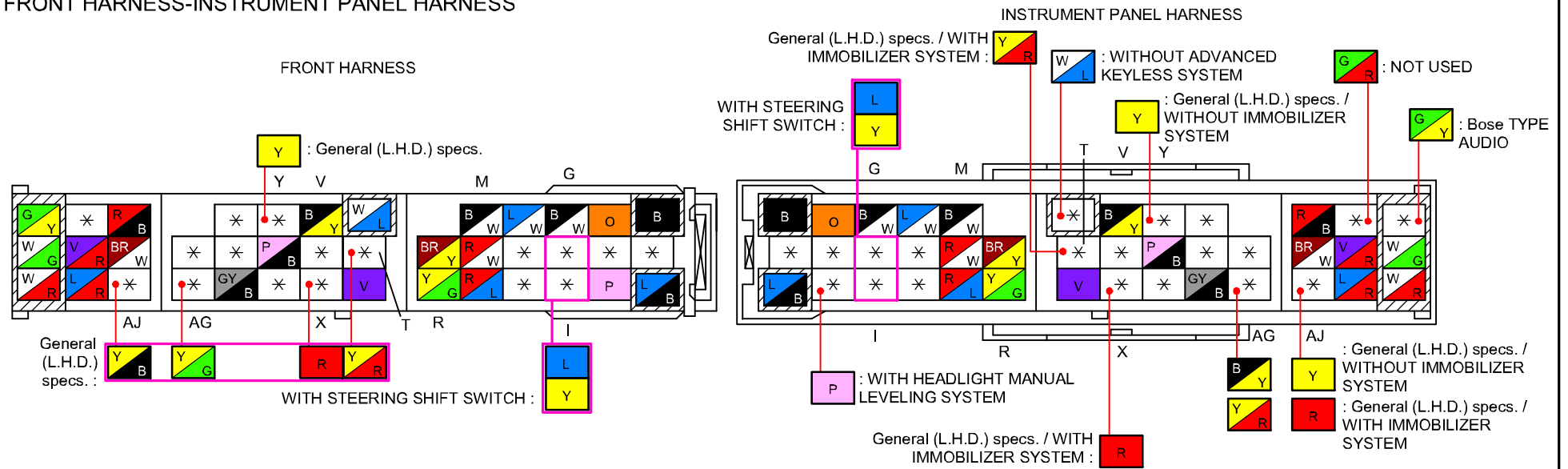

C-16

JOINT CONNECTOR

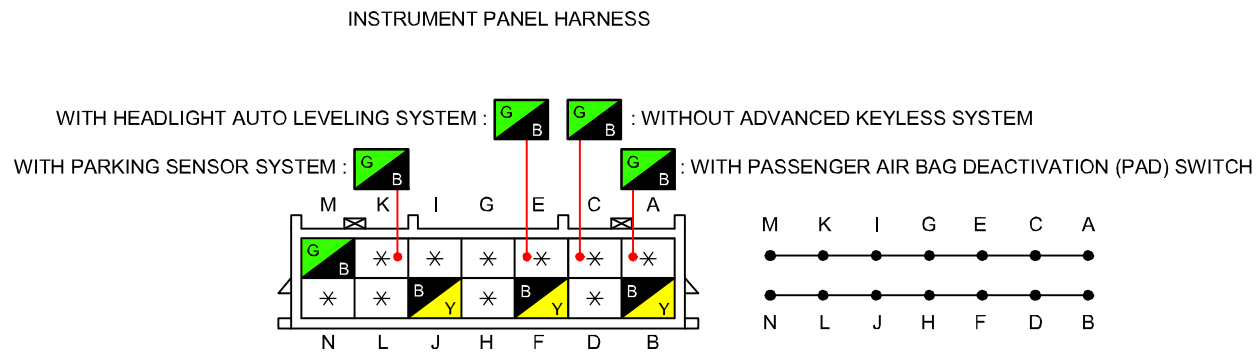

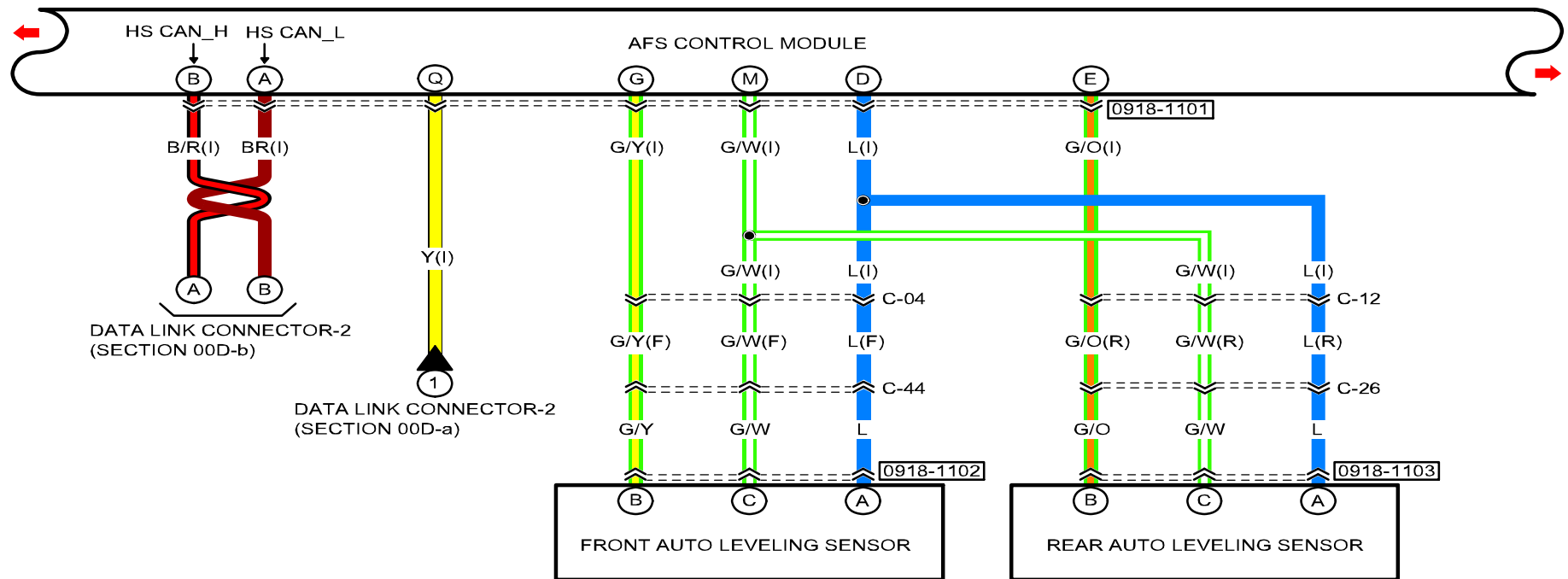

0918-1101
AFS CONTROL MODULE

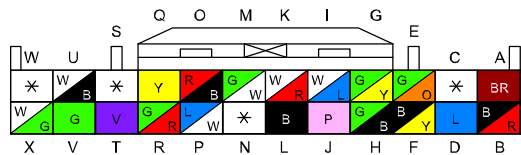

0918-1102
FRONT AUTO LEVELING SENSOR

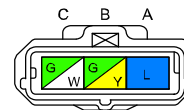

0918-1103
REAR AUTO LEVELING SENSOR

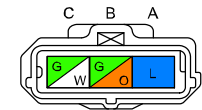

HEADLIGHT AUTO LEVELING SYSTEM / AFS (ADAPTIVE FRONT LIGHTING SYSTEM)

0918-111b

[BLACK]
FRONT AUTO LEVELING SENSOR
0918-1102

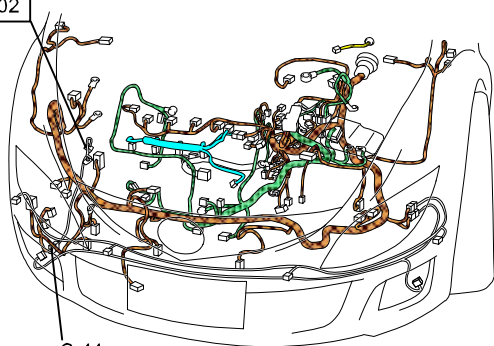

**[EXCEPT MZR-CD
(RF Turbo)]**

(R)-SHORT CORD
C-26

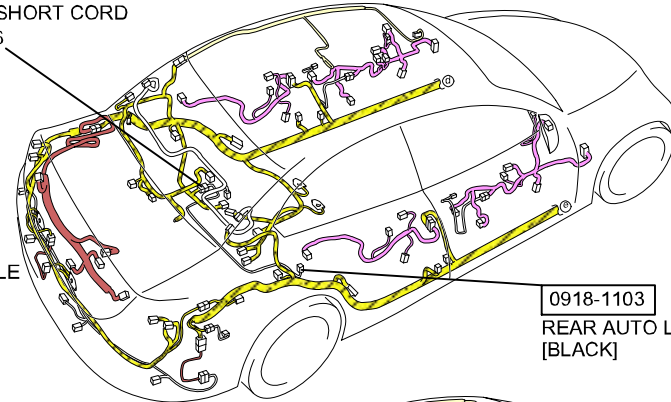

[4SD]

0918-1103
REAR AUTO LEVELING SENSOR
[BLACK]

C-44
(F)-SHORT CORD
[GRAY]

[BLACK]
FRONT AUTO LEVELING SENSOR
0918-1102

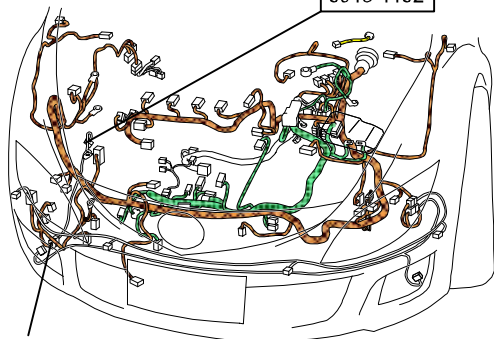

[MZR-CD (RF Turbo)]

AFS CONTROL MODULE
0918-1101

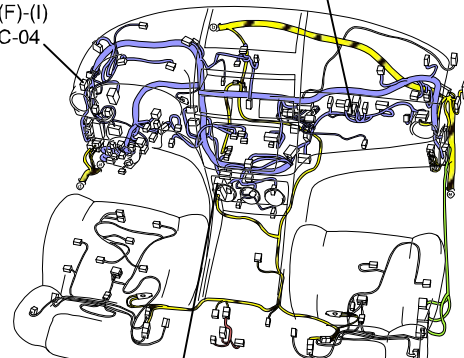

(F)-(L)
C-04

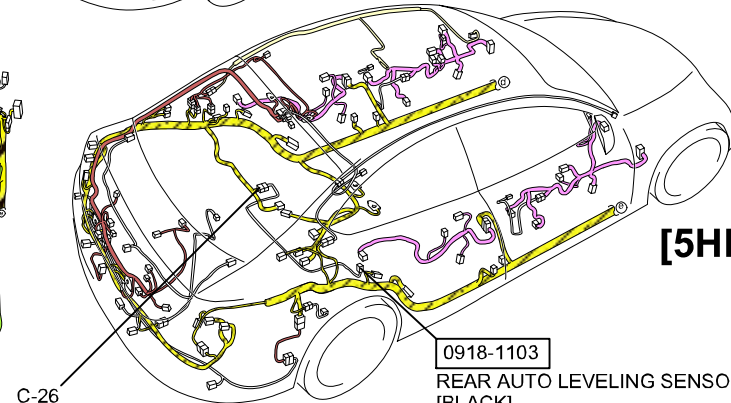

[5HB]

0918-1103
REAR AUTO LEVELING SENSOR
[BLACK]

C-44
(F)-SHORT CORD
[GRAY]

C-12
(L)-(R)
[GRAY]

C-26
(R)-SHORT CORD

- : FRONT HARNESS
- : ENGINE HARNESS
- : INJECTION HARNESS
- : REAR HARNESS
- : REAR NO.2 HARNESS
- : REAR NO.3 HARNESS
- : REAR NO.4 HARNESS
- : REAR NO.5 HARNESS
- : DOOR HARNESS
- : INTERIOR LIGHT HARNESS
- : INTERIOR LIGHT NO.2 HARNESS
- : FLOOR HARNESS
- : INSTRUMENT PANEL HARNESS

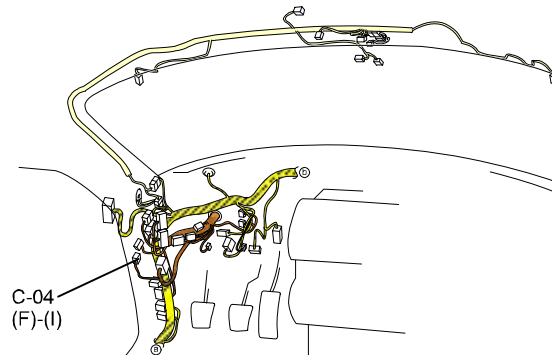

C-04
(F)-(L)

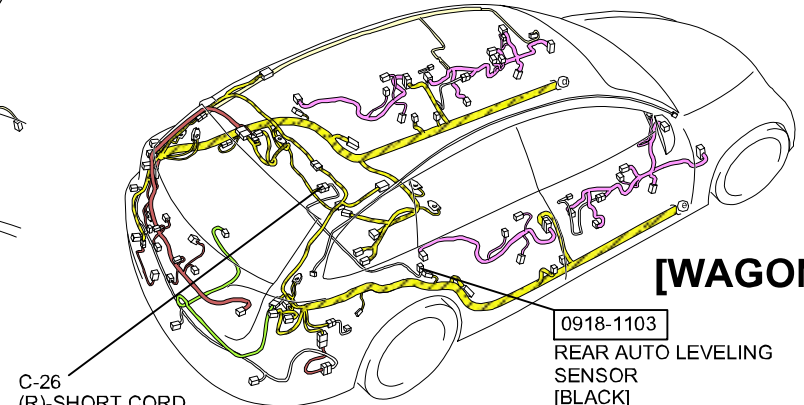

[WAGON]

C-26
(R)-SHORT CORD

0918-1103
REAR AUTO LEVELING SENSOR
[BLACK]

C-04

FRONT HARNESS-INSTRUMENT PANEL HARNESS

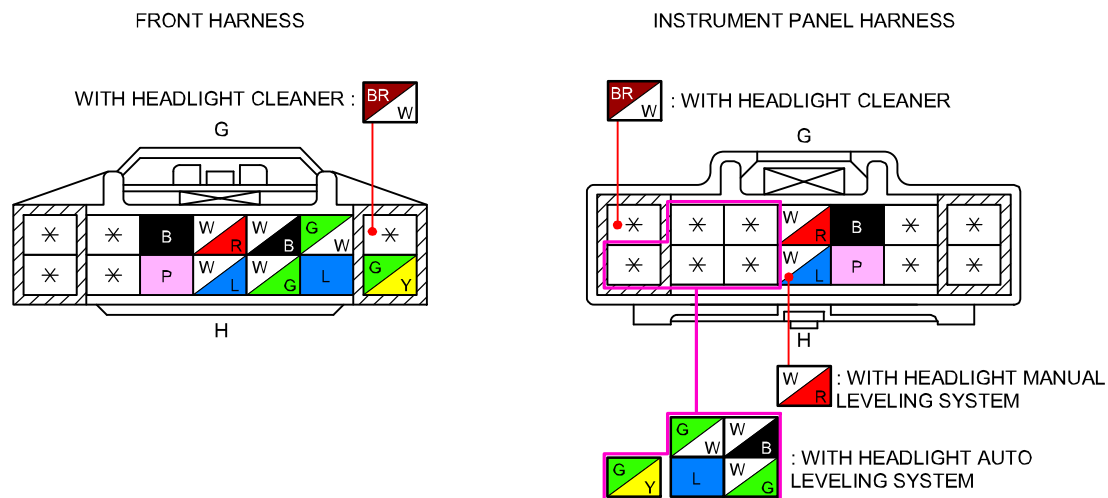

C-12

INSTRUMENT PANEL HARNESS-REAR HARNESS

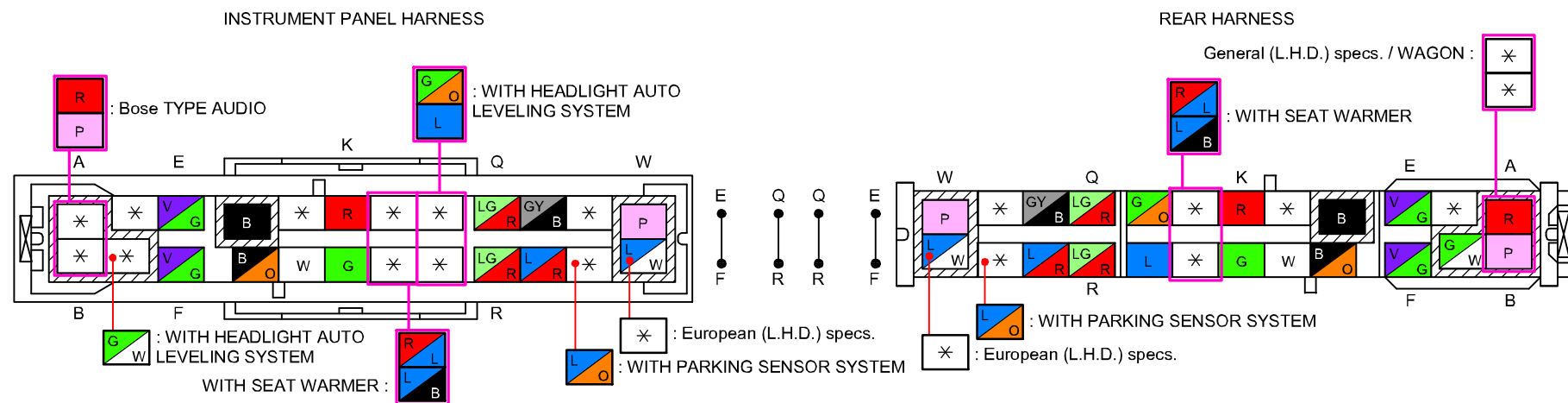

C-26
REAR HARNESS-SHORT CORD

REAR HARNESS

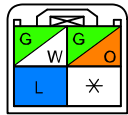

SHORT CORD

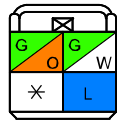

C-44
FRONT HARNESS-SHORT CORD

FRONT HARNESS

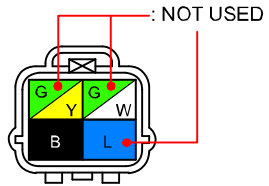

(WITH HEADLIGHT MANUAL LEVELING SYSTEM)

SHORT CORD

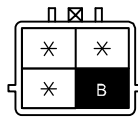

FRONT HARNESS

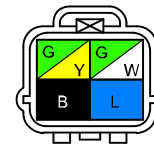

(WITH HEADLIGHT AUTO LEVELING SYSTEM)

SHORT CORD

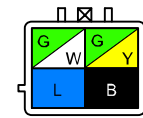

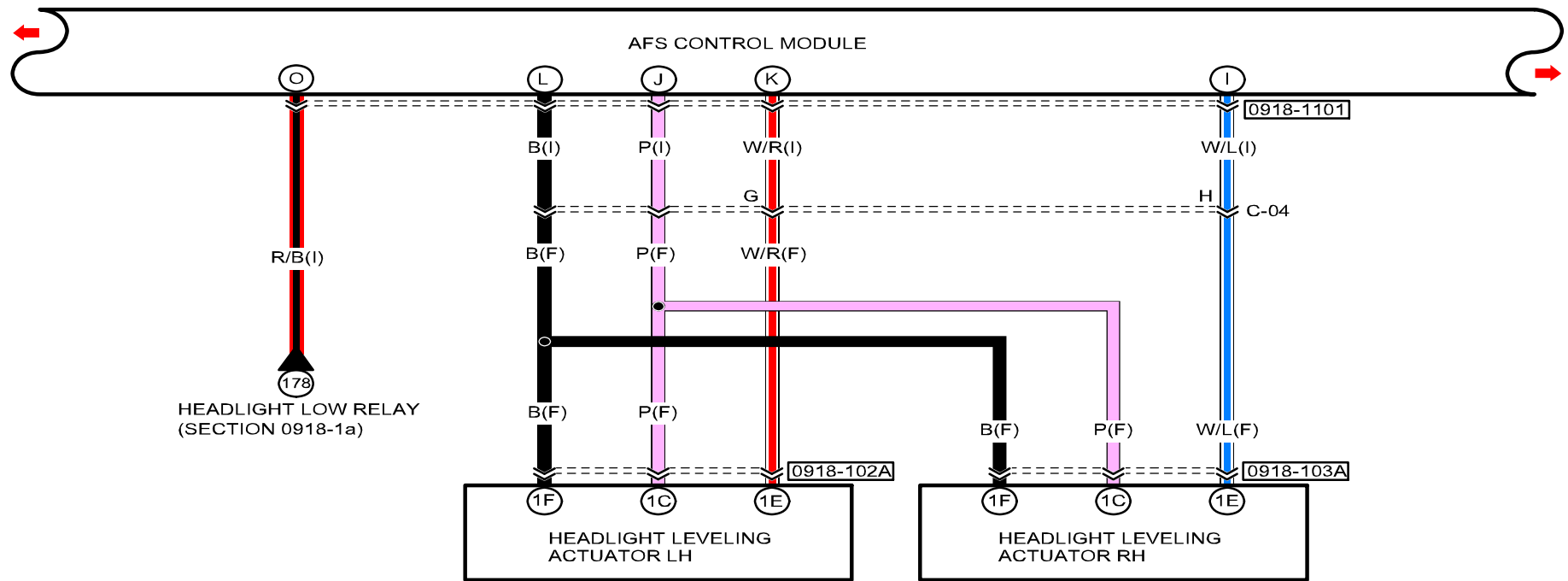

0918-1101
AFS CONTROL MODULE

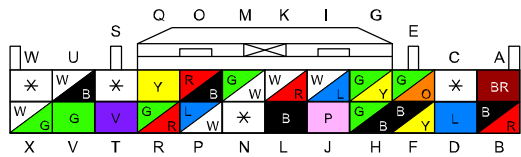

0918-102A
FRONT COMBINATION LIGHT LH /
HEADLIGHT LEVELING ACTUATOR LH

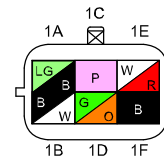

0918-103A
FRONT COMBINATION LIGHT RH /
HEADLIGHT LEVELING ACTUATOR RH

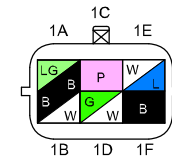

[BLACK]
FRONT COMBINATION LIGHT RH /
HEADLIGHT LEVELING ACTUATOR RH
0918-103A

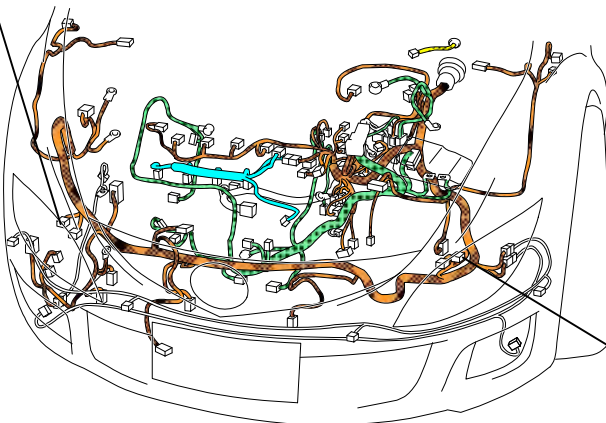

[EXCEPT MZR-CD (RF Turbo)]

[BLACK]
FRONT COMBINATION LIGHT RH /
HEADLIGHT LEVELING ACTUATOR RH
0918-103A

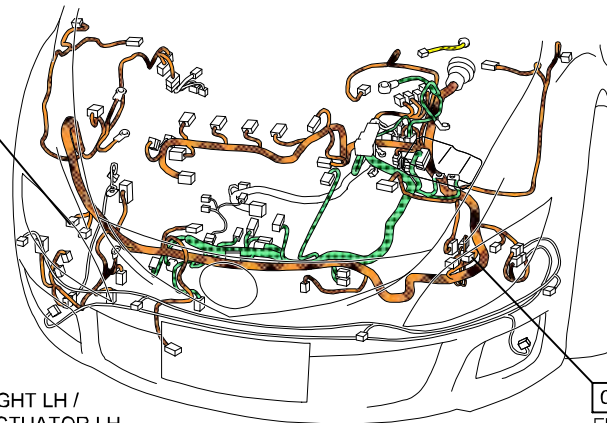

[MZR-CD (RF Turbo)]

0918-102A
FRONT COMBINATION LIGHT LH /
HEADLIGHT LEVELING ACTUATOR LH
[BLACK]

0918-102A
FRONT COMBINATION
LIGHT LH /
HEADLIGHT LEVELING
ACTUATOR LH
[BLACK]

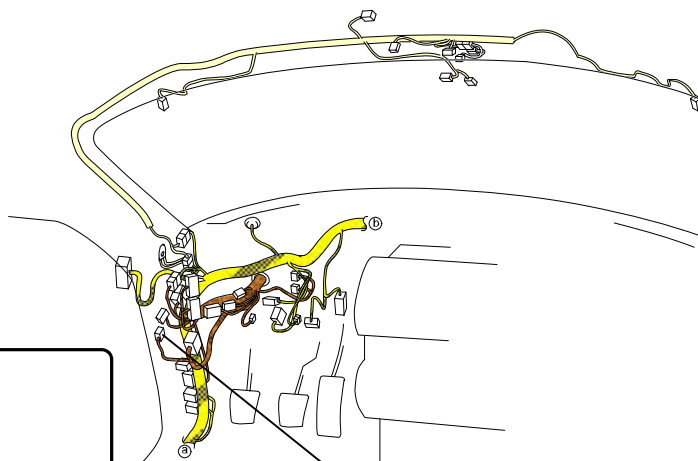

C-04
(F)-(I)

- : FRONT HARNESS
- : ENGINE HARNESS
- : INJECTION HARNESS
- : REAR HARNESS
- : REAR NO.5 HARNESS
- : INSTRUMENT PANEL HARNESS
- : FLOOR HARNESS
- : INTERIOR LIGHT NO.2 HARNESS

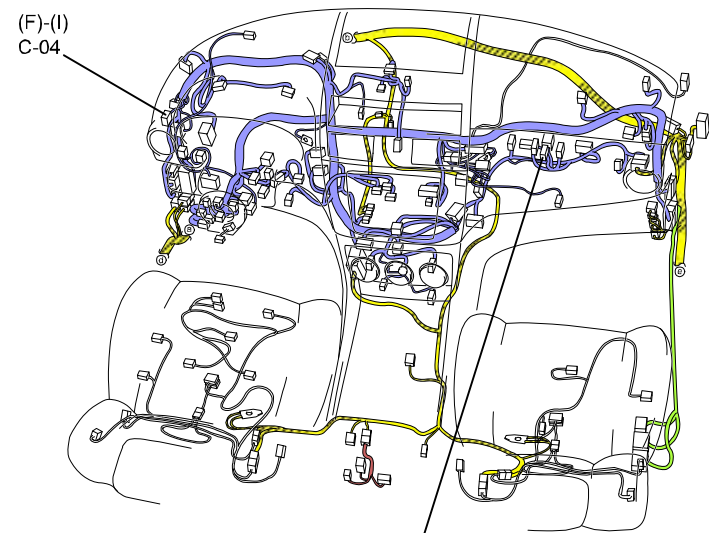

0918-1101
AFS CONTROL MODULE

C-04

FRONT HARNESS-INSTRUMENT PANEL HARNESS

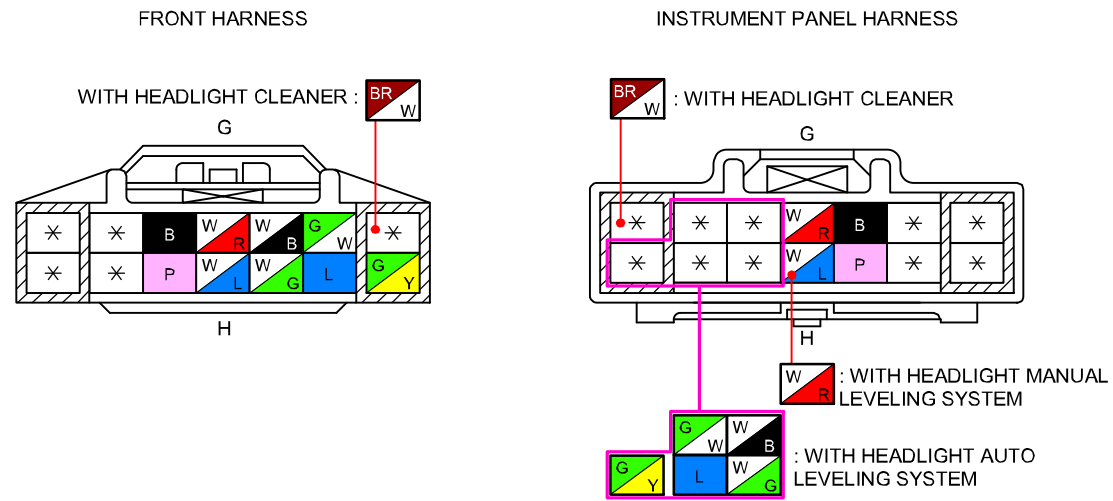

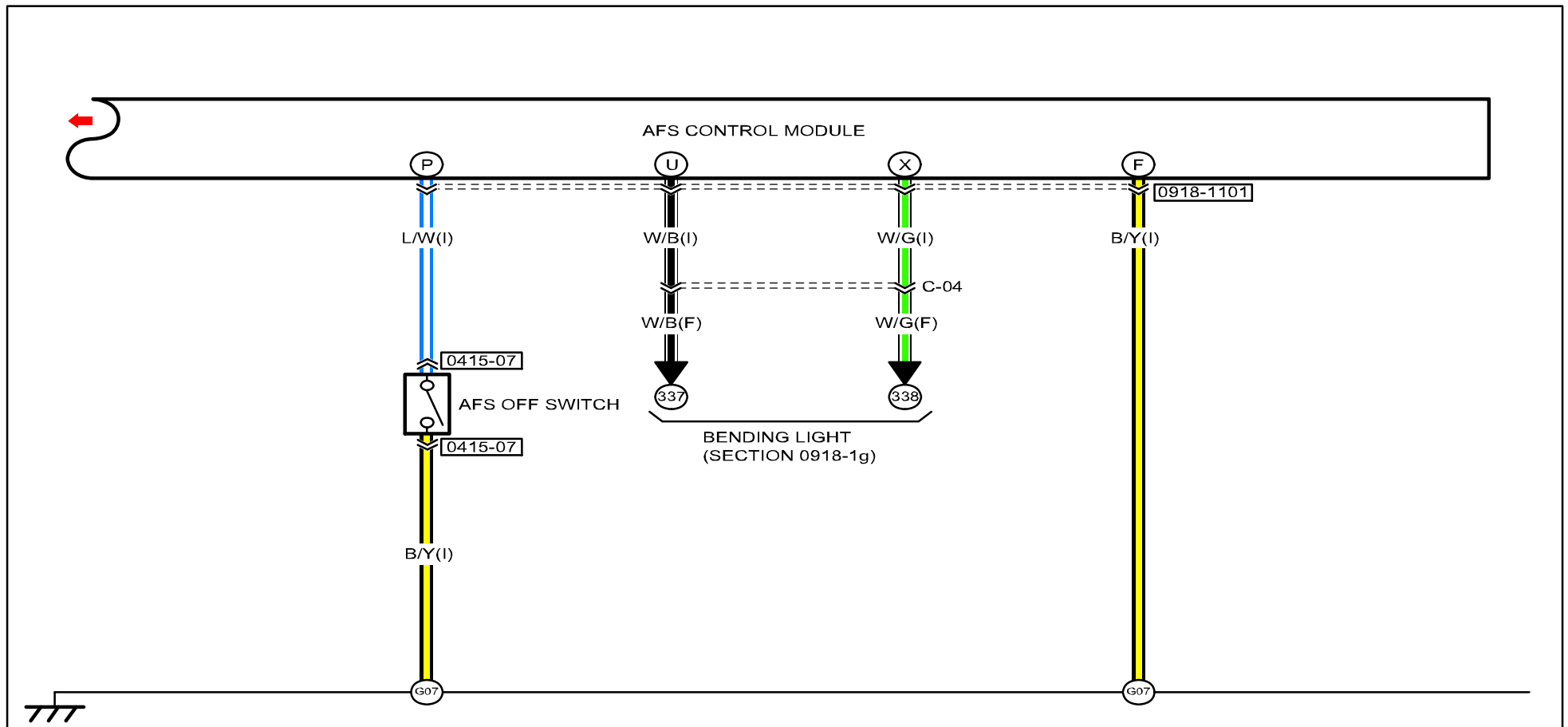

0918-1101
AFS CONTROL MODULE

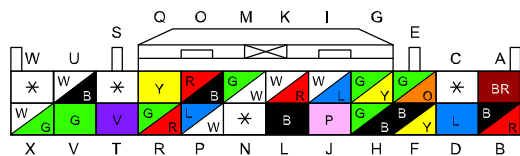

0415-07
DSC OFF SWITCH / AFS OFF SWITCH /
HEADLIGHT LEVELING SWITCH /
DSC OFF SWITCH ILLUMINATION /
AFS OFF SWITCH ILLUMINATION /
HEADLIGHT LEVELING SWITCH ILLUMINATION

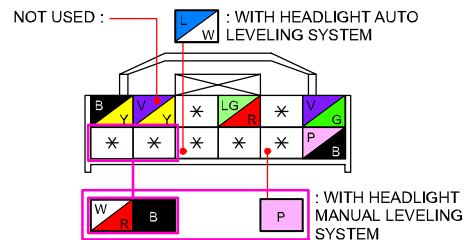

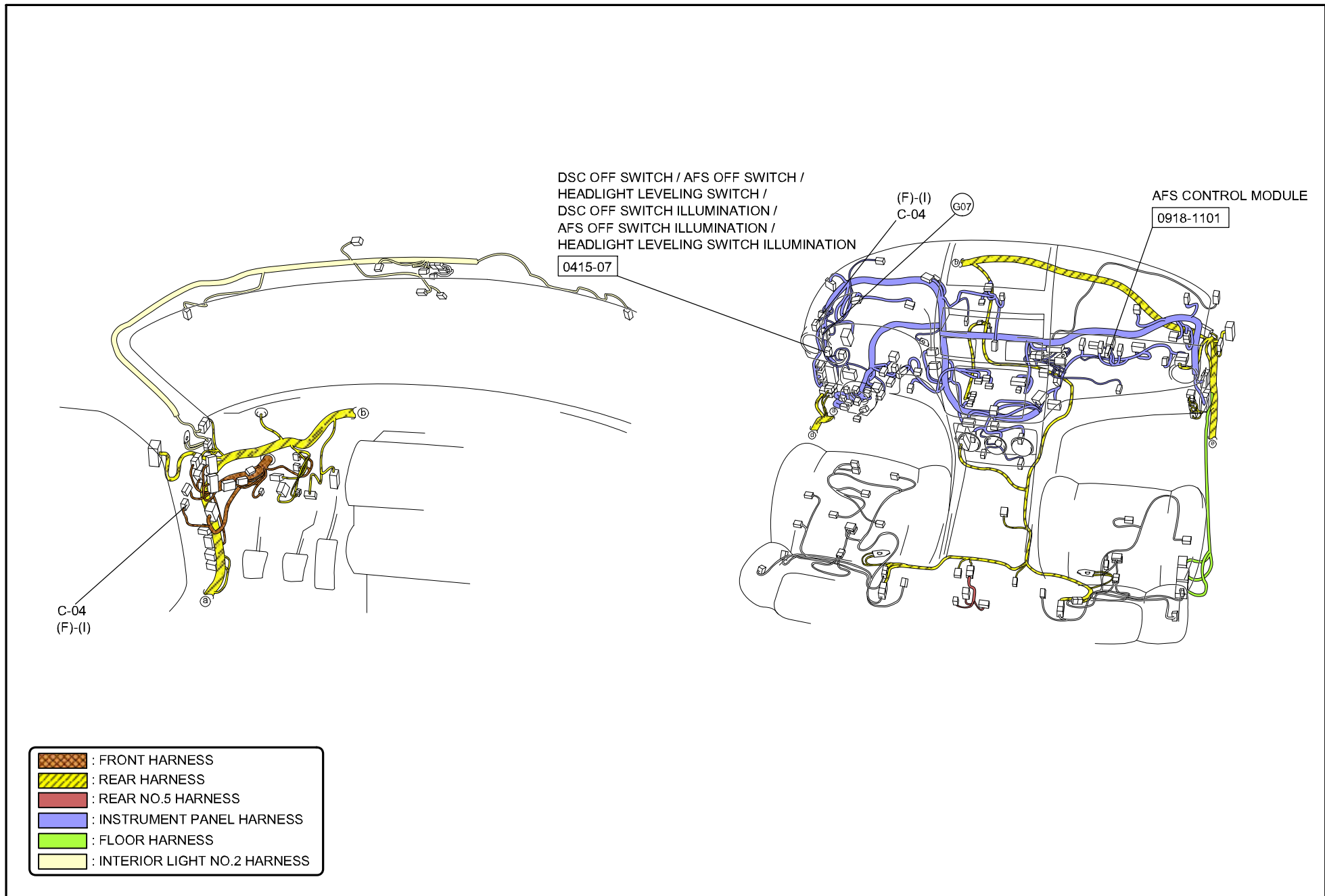

C-04

FRONT HARNESS-INSTRUMENT PANEL HARNESS

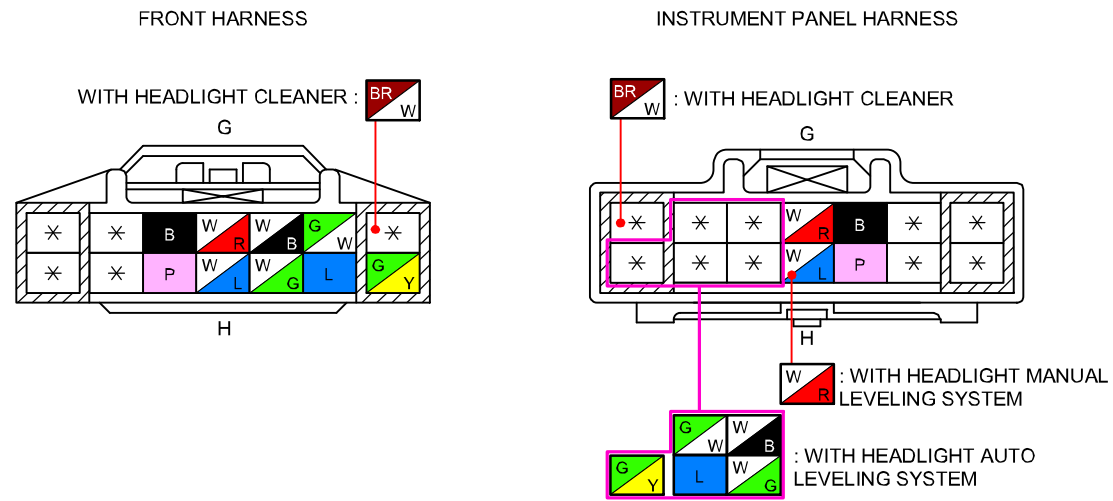

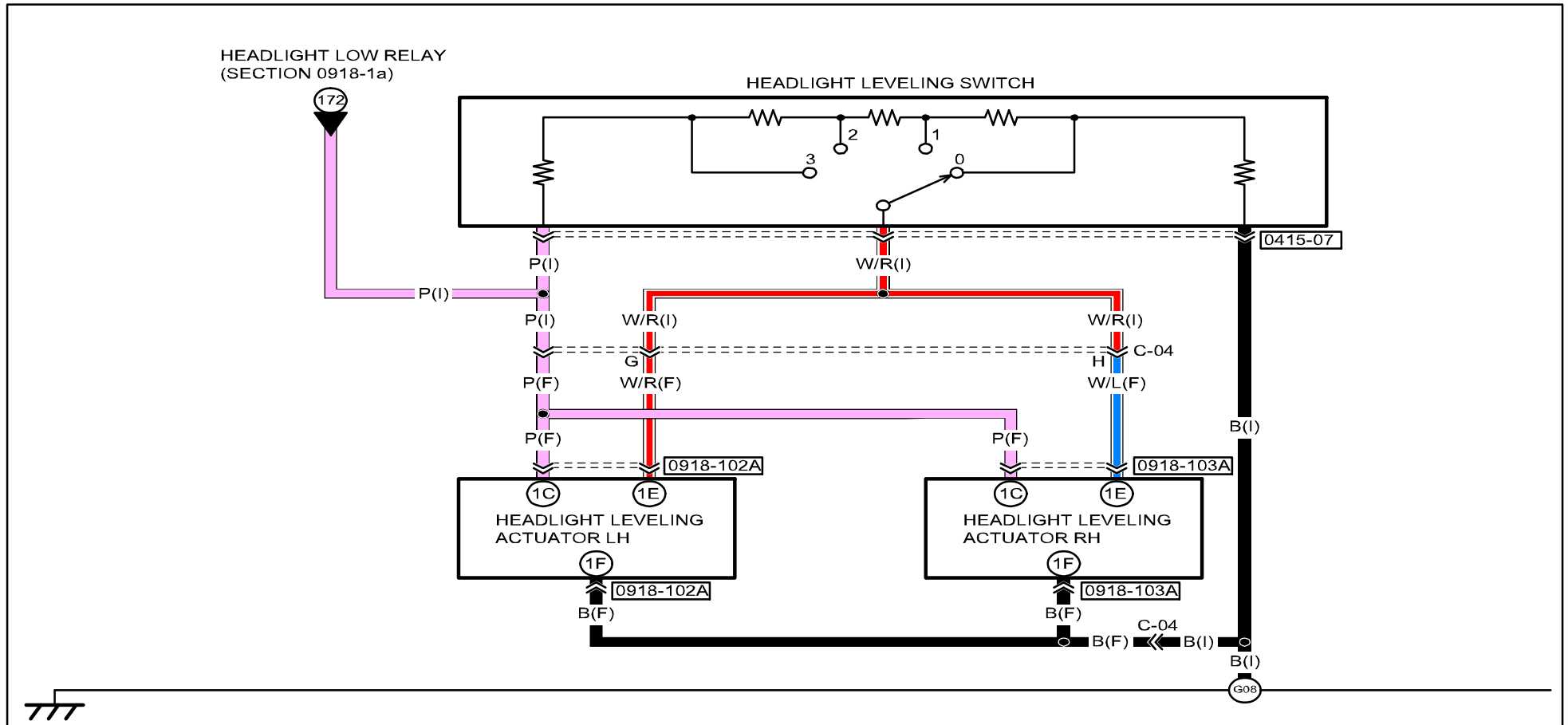

0415-07
 DSC OFF SWITCH / AFS OFF SWITCH /
 HEADLIGHT LEVELING SWITCH / DSC OFF SWITCH ILLUMINATION /
 AFS OFF SWITCH ILLUMINATION / HEADLIGHT LEVELING SWITCH ILLUMINATION

NOT USED : : WITH HEADLIGHT AUTO LEVELING SYSTEM

: WITH HEADLIGHT MANUAL LEVELING SYSTEM

0918-102A
 FRONT COMBINATION LIGHT LH /
 HEADLIGHT LEVELING ACTUATOR LH

0918-103A
 FRONT COMBINATION LIGHT RH /
 HEADLIGHT LEVELING ACTUATOR RH

[BLACK]
FRONT COMBINATION LIGHT RH /
HEADLIGHT LEVELING ACTUATOR RH
0918-103A

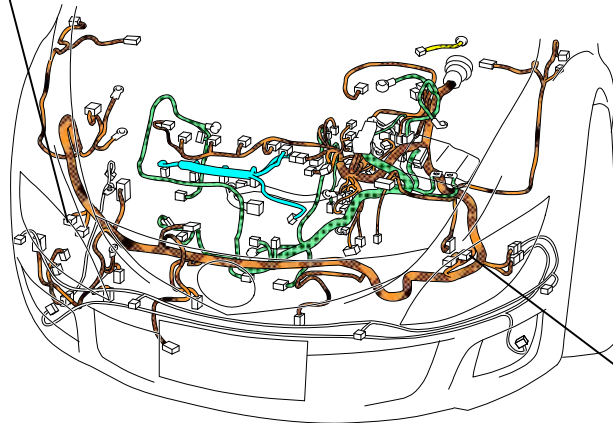

[EXCEPT MZR-CD (RF Turbo)]



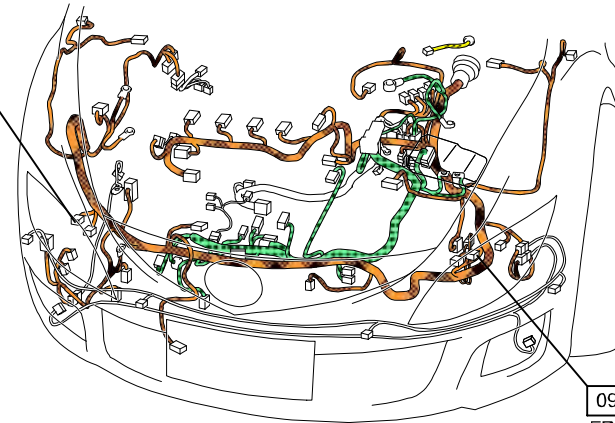





[BLACK]
FRONT COMBINATION LIGHT RH /
HEADLIGHT LEVELING ACTUATOR RH
0918-103A



[MZR-CD (RF Turbo)]

0918-102A
FRONT COMBINATION LIGHT LH /
HEADLIGHT LEVELING ACTUATOR
LH
[BLACK]

0918-102A
FRONT COMBINATION
LIGHT LH /
HEADLIGHT LEVELING
ACTUATOR LH
[BLACK]

-  : FRONT HARNESS
-  : ENGINE HARNESS
-  : INJECTION HARNESS
-  : REAR HARNESS
-  : REAR NO.5 HARNESS
-  : INSTRUMENT PANEL HARNESS
-  : FLOOR HARNESS
-  : INTERIOR LIGHT NO.2 HARNESS

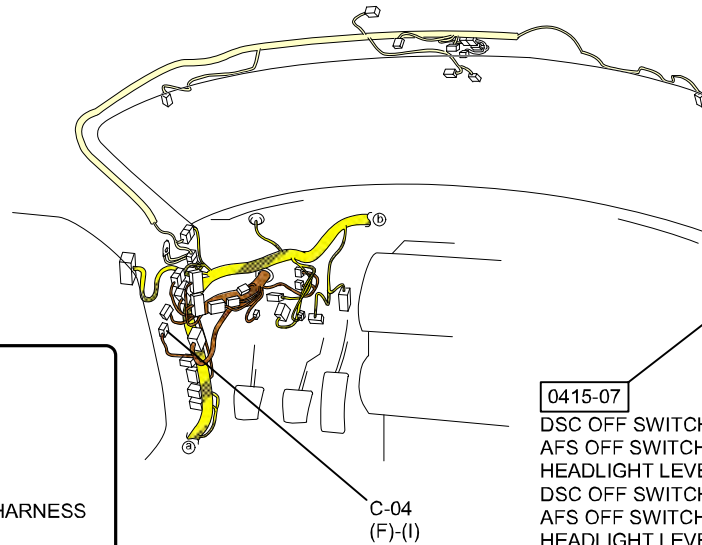

0415-07
DSC OFF SWITCH /
AFS OFF SWITCH /
HEADLIGHT LEVELING SWITCH /
DSC OFF SWITCH ILLUMINATION /
AFS OFF SWITCH ILLUMINATION /
HEADLIGHT LEVELING SWITCH ILLUMINATION

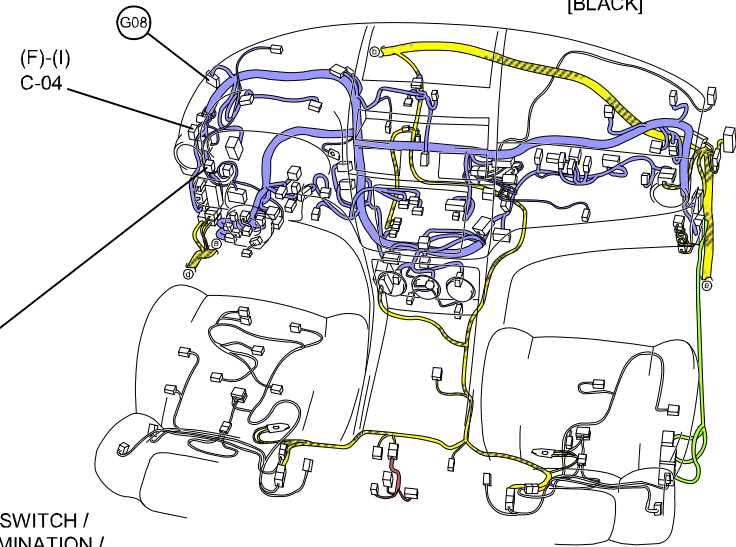

C-04

FRONT HARNESS-INSTRUMENT PANEL HARNESS

FRONT HARNESS

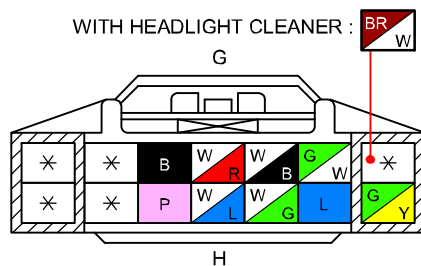

INSTRUMENT PANEL HARNESS

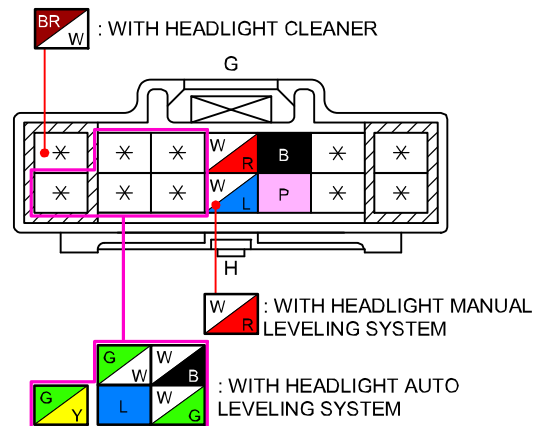

ILLUMINATION LIGHT

0918-13a

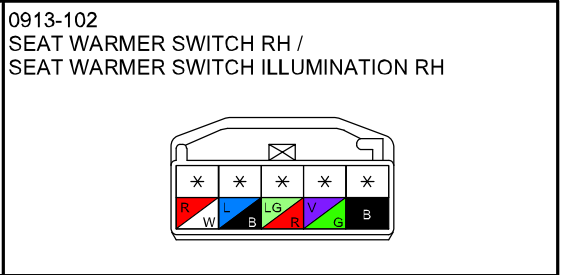
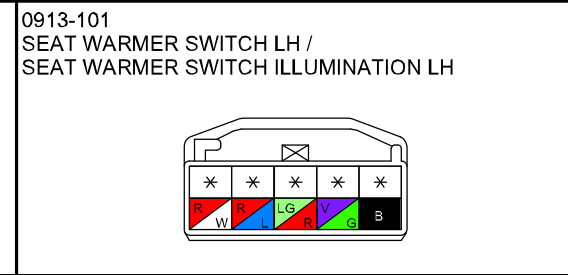
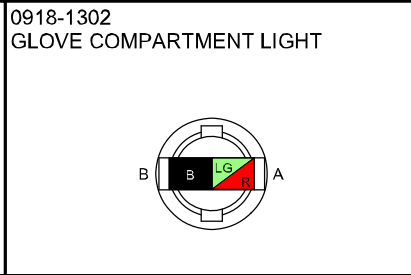
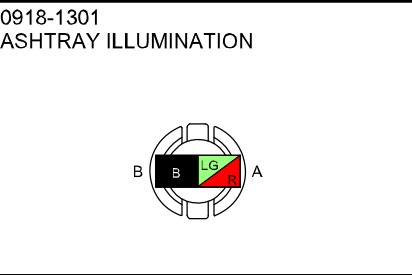
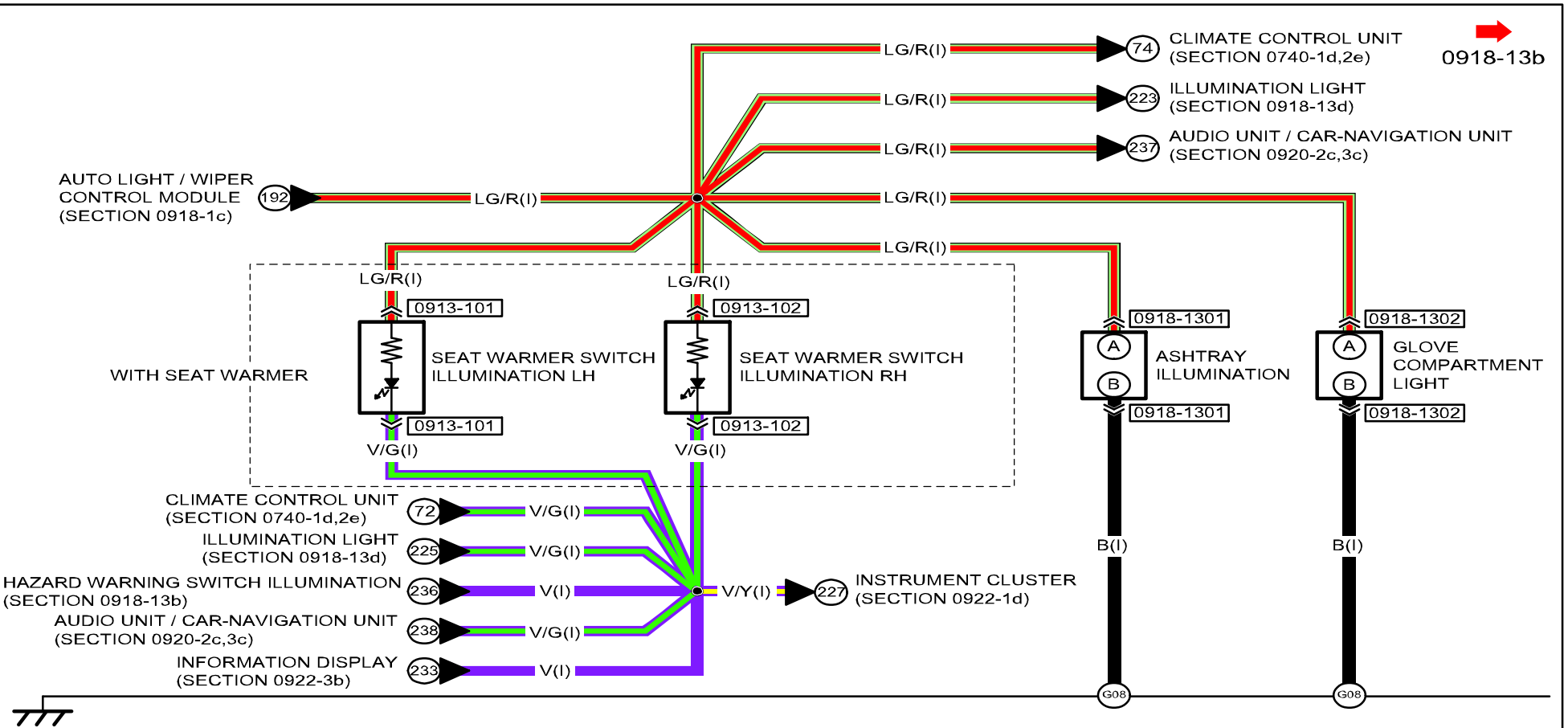

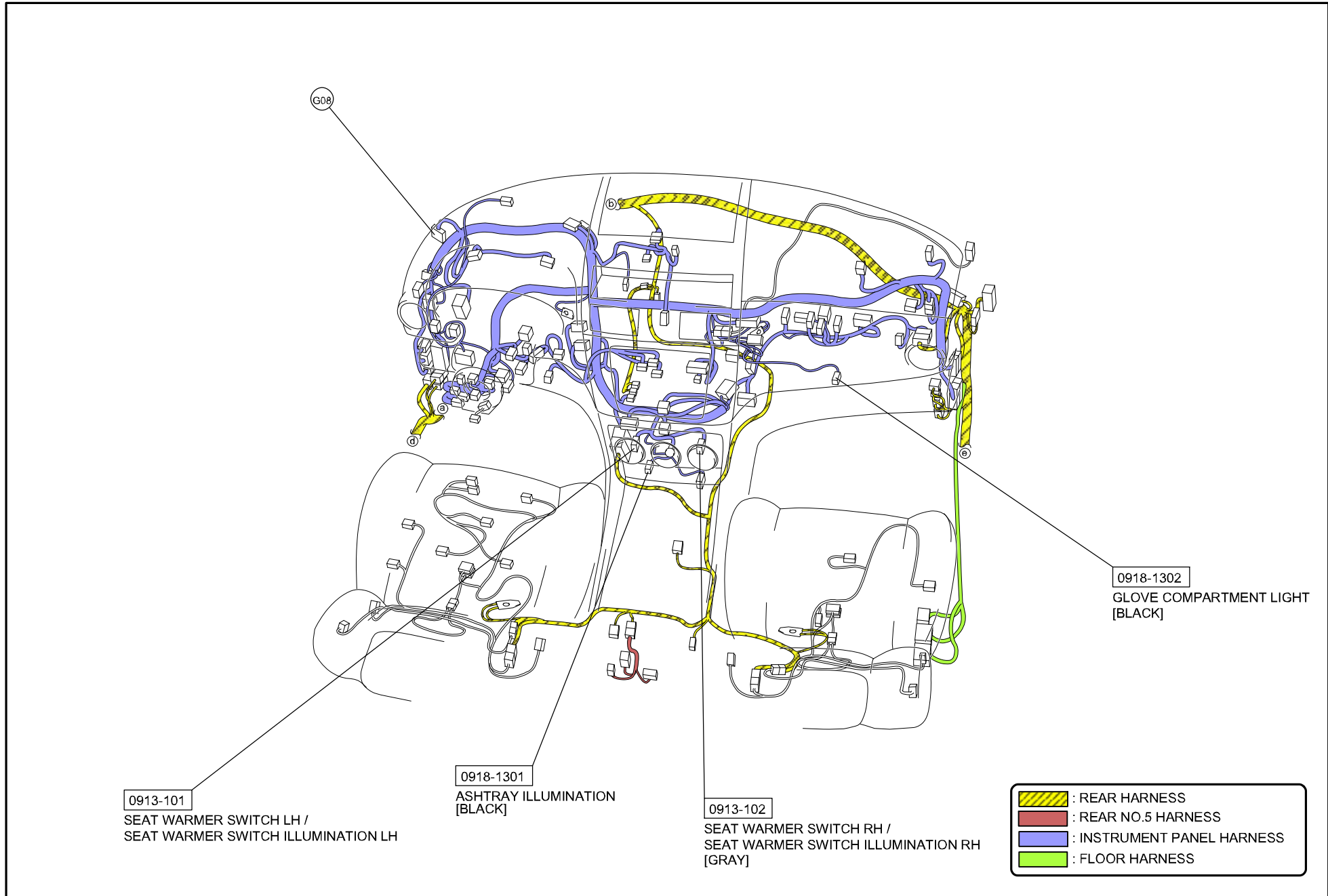

ILLUMINATION LIGHT

0918-13b

0918-13a

#1 : WITH DSC
 #2 : WITH AFS
 #3 : WITH HEADLIGHT MANUAL LEVELING SYSTEM

0918-13c

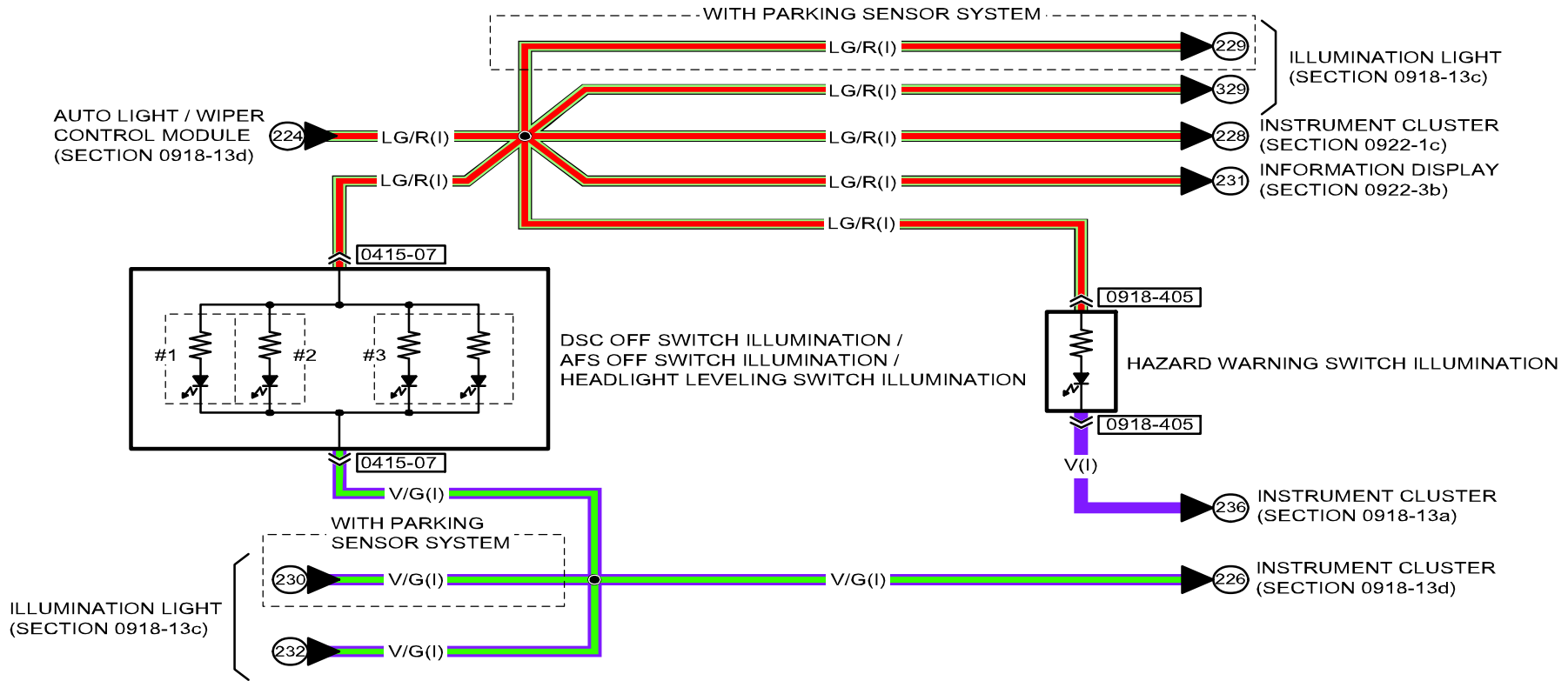

0415-07
 DSC OFF SWITCH / AFS OFF SWITCH /
 HEADLIGHT LEVELING SWITCH / DSC OFF SWITCH ILLUMINATION /
 AFS OFF SWITCH ILLUMINATION / HEADLIGHT LEVELING SWITCH ILLUMINATION

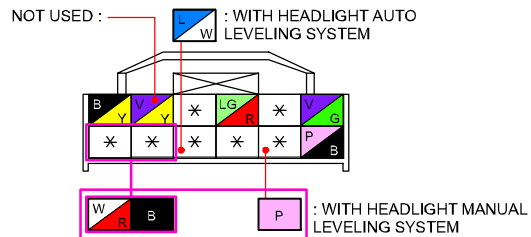

0918-405
 HAZARD WARNING SWITCH /
 HAZARD WARNING SWITCH ILLUMINATION

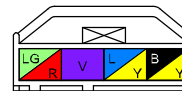





DSC OFF SWITCH /
AFS OFF SWITCH /
HEADLIGHT LEVELING SWITCH /
DSC OFF SWITCH ILLUMINATION /
AFS OFF SWITCH ILLUMINATION /
HEADLIGHT LEVELING SWITCH ILLUMINATION

0415-07

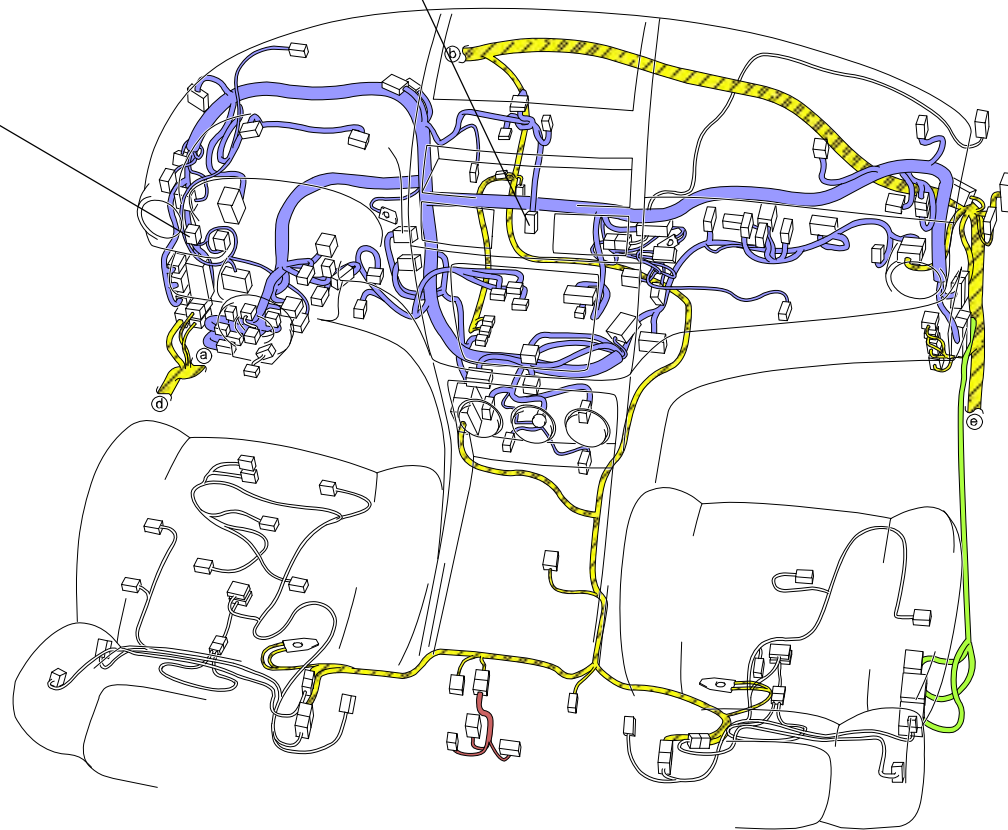
HAZARD WARNING SWITCH /
HAZARD WARNING SWITCH ILLUMINATION

0918-405



-  : REAR HARNESS
-  : REAR NO.5 HARNESS
-  : INSTRUMENT PANEL HARNESS
-  : FLOOR HARNESS

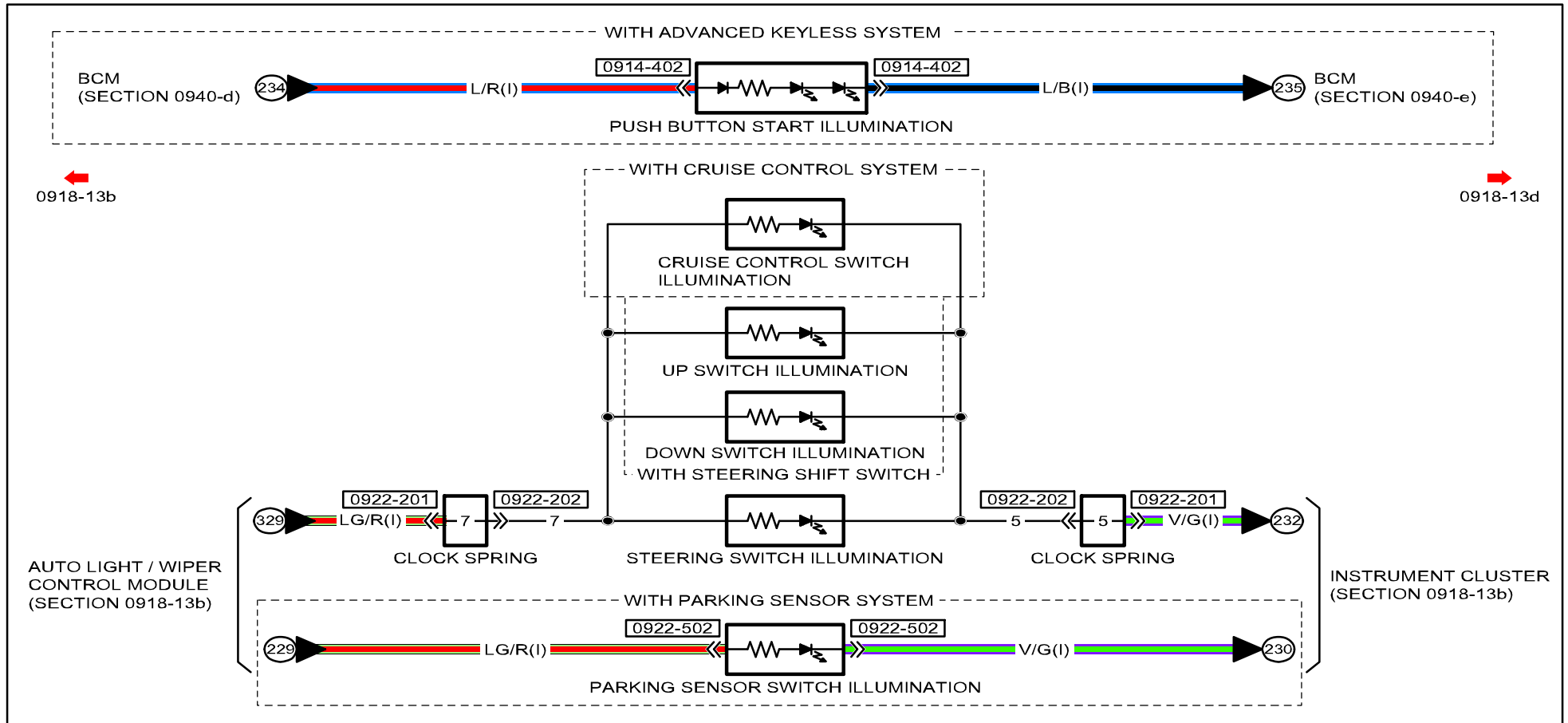

0914-402
PUSH BUTTON START /
PUSH BUTTON START ILLUMINATION

0922-502
PARKING SENSOR SWITCH ILLUMINATION /
PARKING SENSOR SWITCH

0922-201
CLOCK SPRING

Y L : WITH STEERING SHIFT SWITCH

P : WITH HANDS-FREE TELEPHONE (HF/TEL) SYSTEM

0922-202
CRUISE CONTROL SWITCH /
UP SWITCH / DOWN SWITCH /
STEERING SWITCH ILLUMINATION /
UP SWITCH ILLUMINATION /
DOWN SWITCH ILLUMINATION /
CRUISE CONTROL SWITCH ILLUMINATION /
STEERING SWITCH /
CLOCK SPRING

TERMINALS OF THIS CONNECTOR
ARE INDICATED BY NUMBERS.

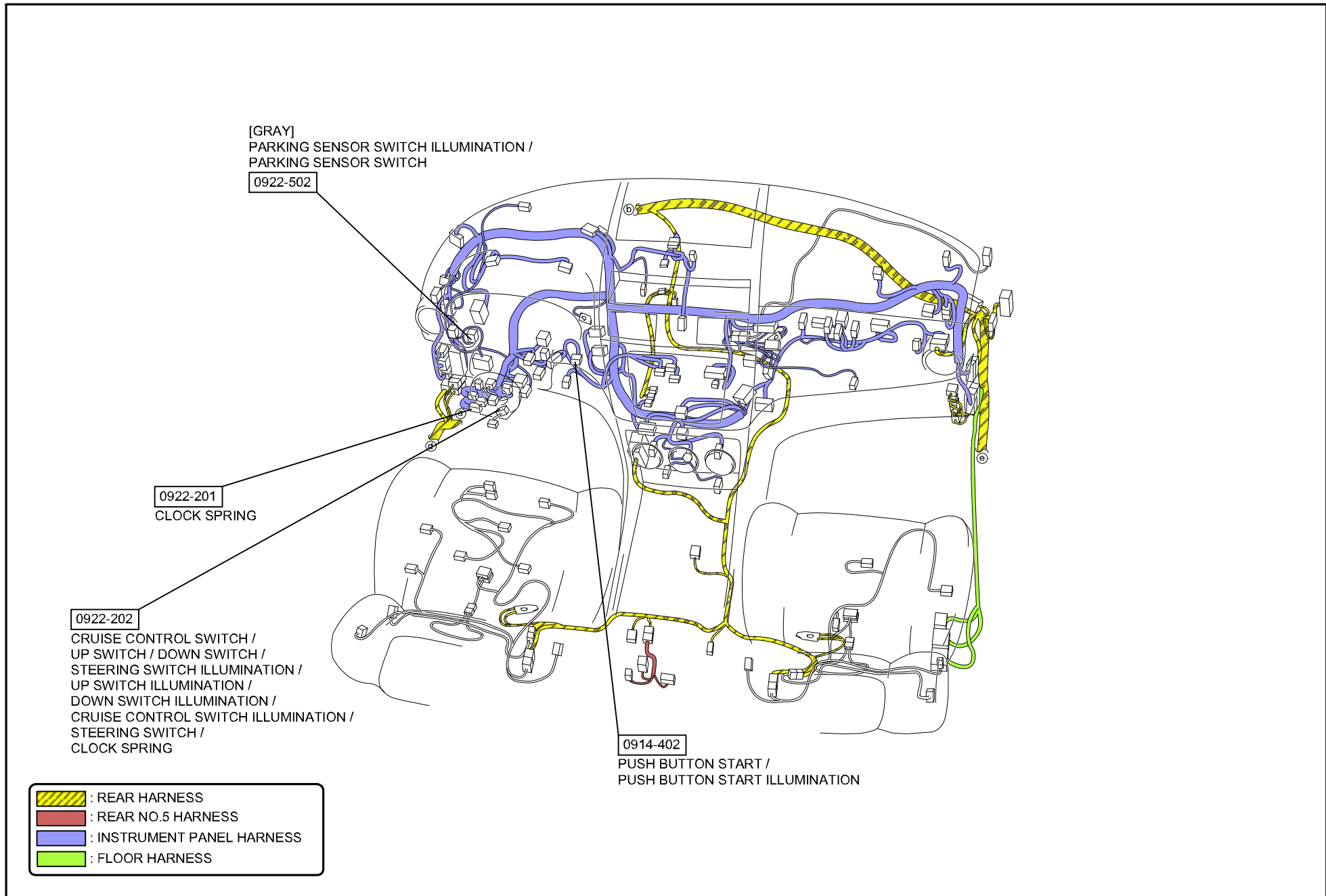

ILLUMINATION LIGHT

0918-13d

0918-13c

[] : 5HB
@2 : WITH ADVANCED KEYLESS SYSTEM

AUTO LIGHT / WIPER CONTROL MODULE (SECTION 0918-13a)

223

C-12



ILLUMINATION LIGHT (SECTION 0918-13b)

224



EXCEPT 5HB

C-34 [C-43] 5HB

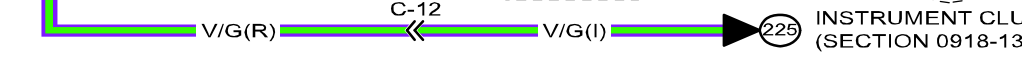
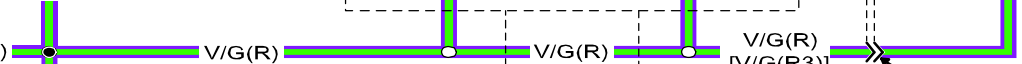
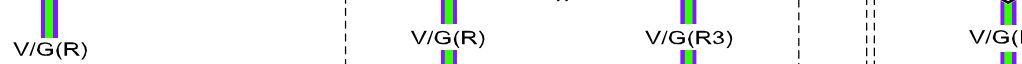
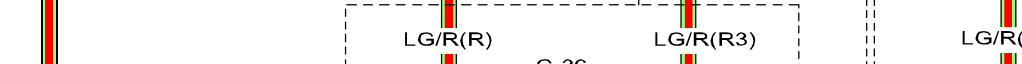

ILLUMINATION LIGHT (SECTION 0918-13b)

226

C-12



INSTRUMENT CLUSTER (SECTION 0918-13a)

225

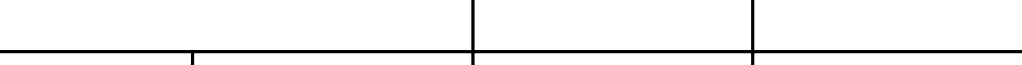
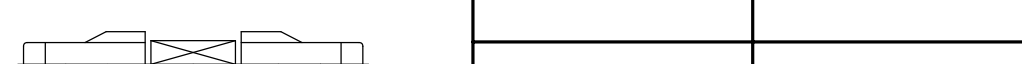
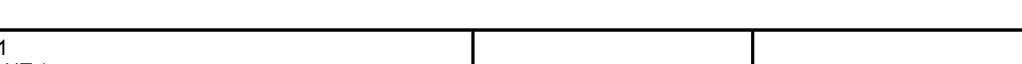
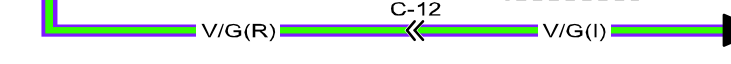

0517-04
SELECTOR LEVER COMPONENT /
SELECTOR ILLUMINATION

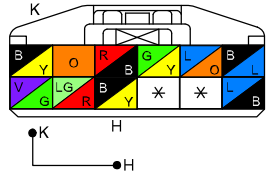

0918-701
MAP LIGHT /
DOWN LIGHT

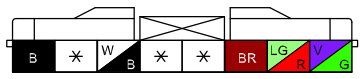

ILLUMINATION LIGHT

0918-13d

- : INSTRUMENT PANEL HARNESS
- : REAR HARNESS
- : REAR NO.2 HARNESS
- : REAR NO.3 HARNESS
- : REAR NO.4 HARNESS
- : REAR NO.5 HARNESS
- : DOOR HARNESS
- : INTERIOR LIGHT HARNESS
- : FLOOR HARNESS

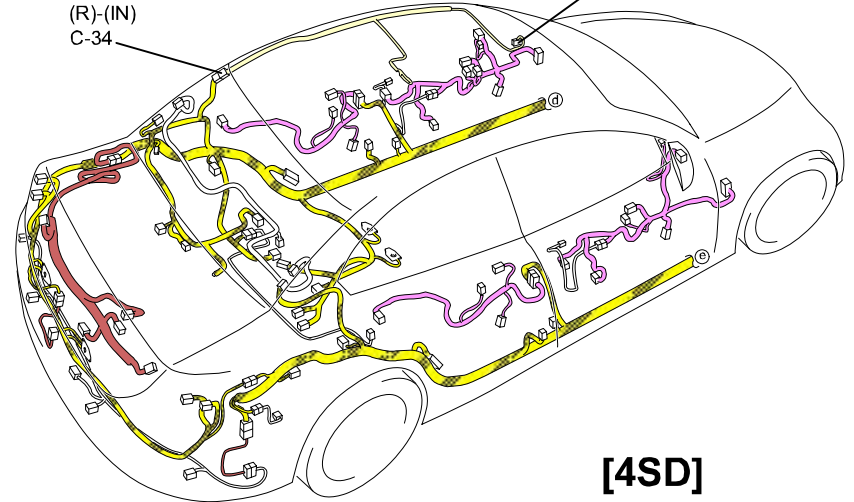
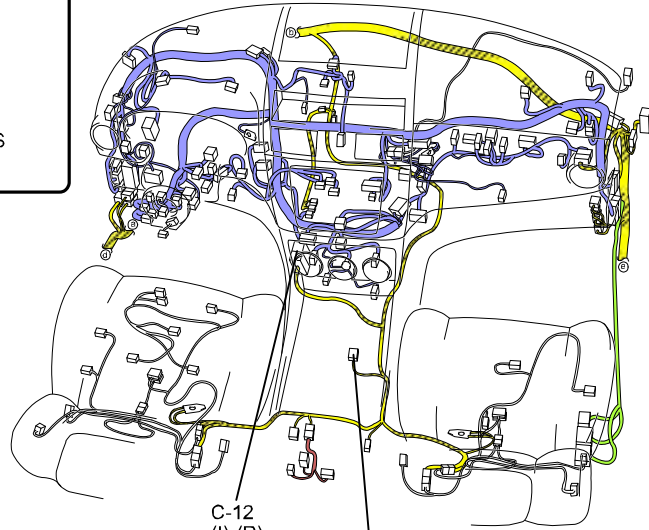

(R3)-(IN)
C-43

(R)-(R3)
C-36

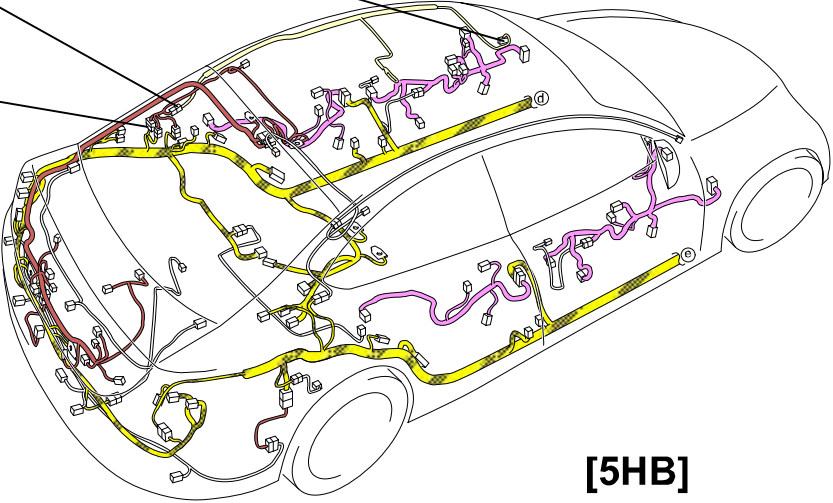

(R)-(IN)
C-34

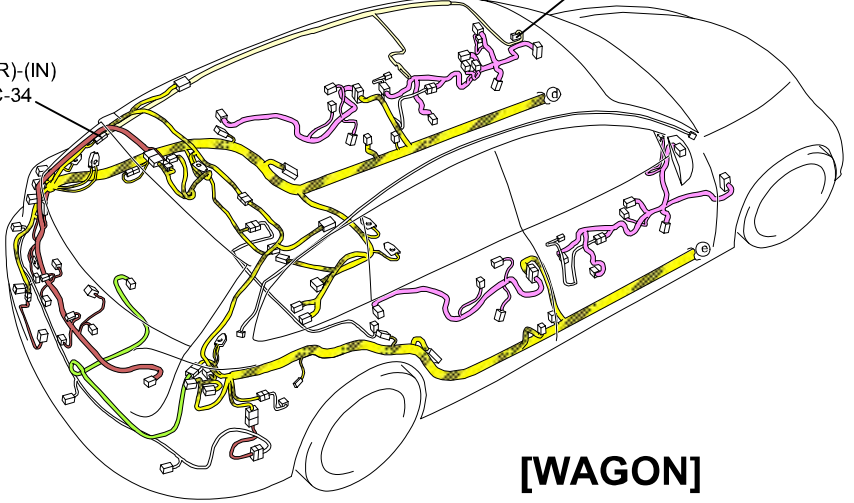

[GRAY]
MAP LIGHT / DOWN LIGHT
0918-701

C-12
(I)-(R)
[GRAY]

0517-04
SELECTOR LEVER COMPONENT /
SELECTOR ILLUMINATION

[GRAY]
MAP LIGHT / DOWN LIGHT
0918-701

[4SD]

[GRAY]
MAP LIGHT / DOWN LIGHT
0918-701

[5HB]

[WAGON]

C-12
INSTRUMENT PANEL HARNESS-REAR HARNESS

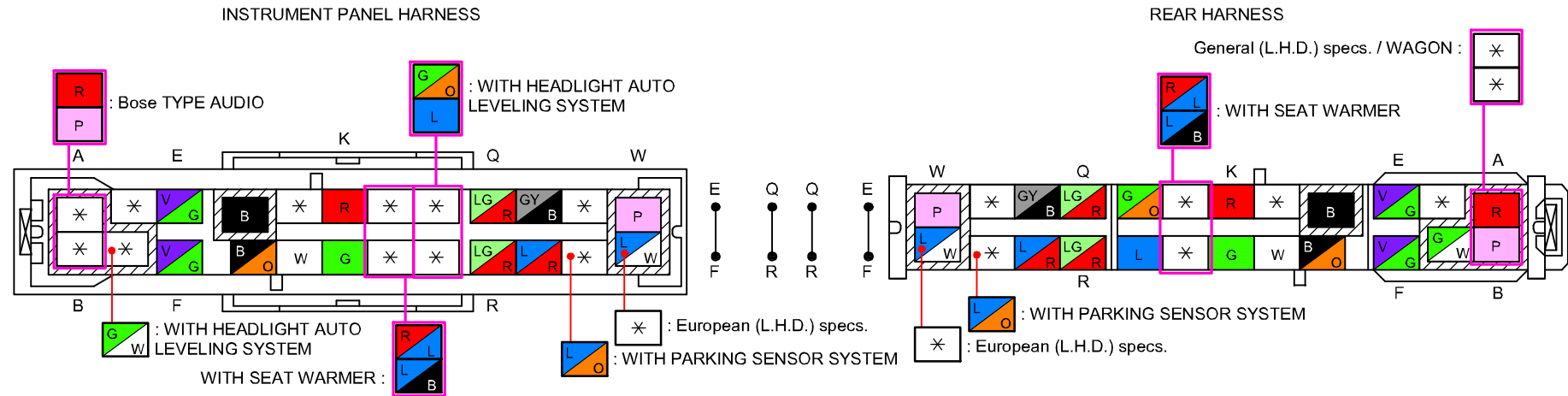

C-34
REAR HARNESS-INTERIOR LIGHT HARNESS

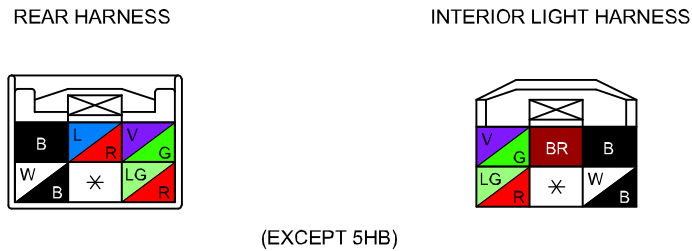

C-36
REAR HARNESS-REAR NO.3 HARNESS

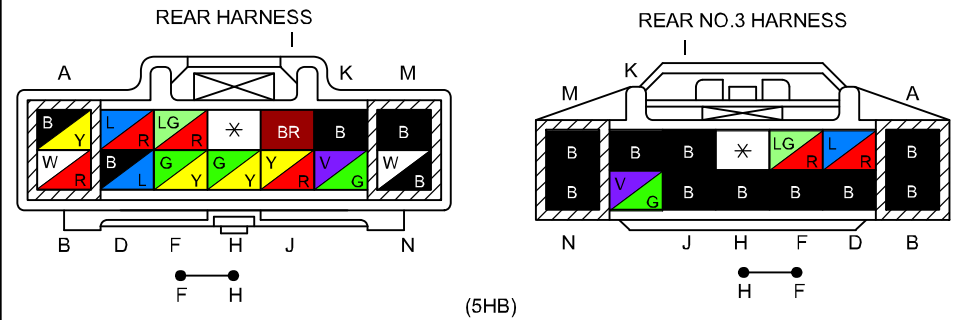

C-43

REAR NO.3 HARNESS-INTERIOR LIGHT HARNESS

REAR NO.3 HARNESS

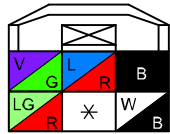

INTERIOR LIGHT HARNESS

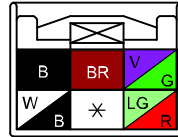

(5HB)

WINDSHIELD WIPER AND WASHER

0919-1a

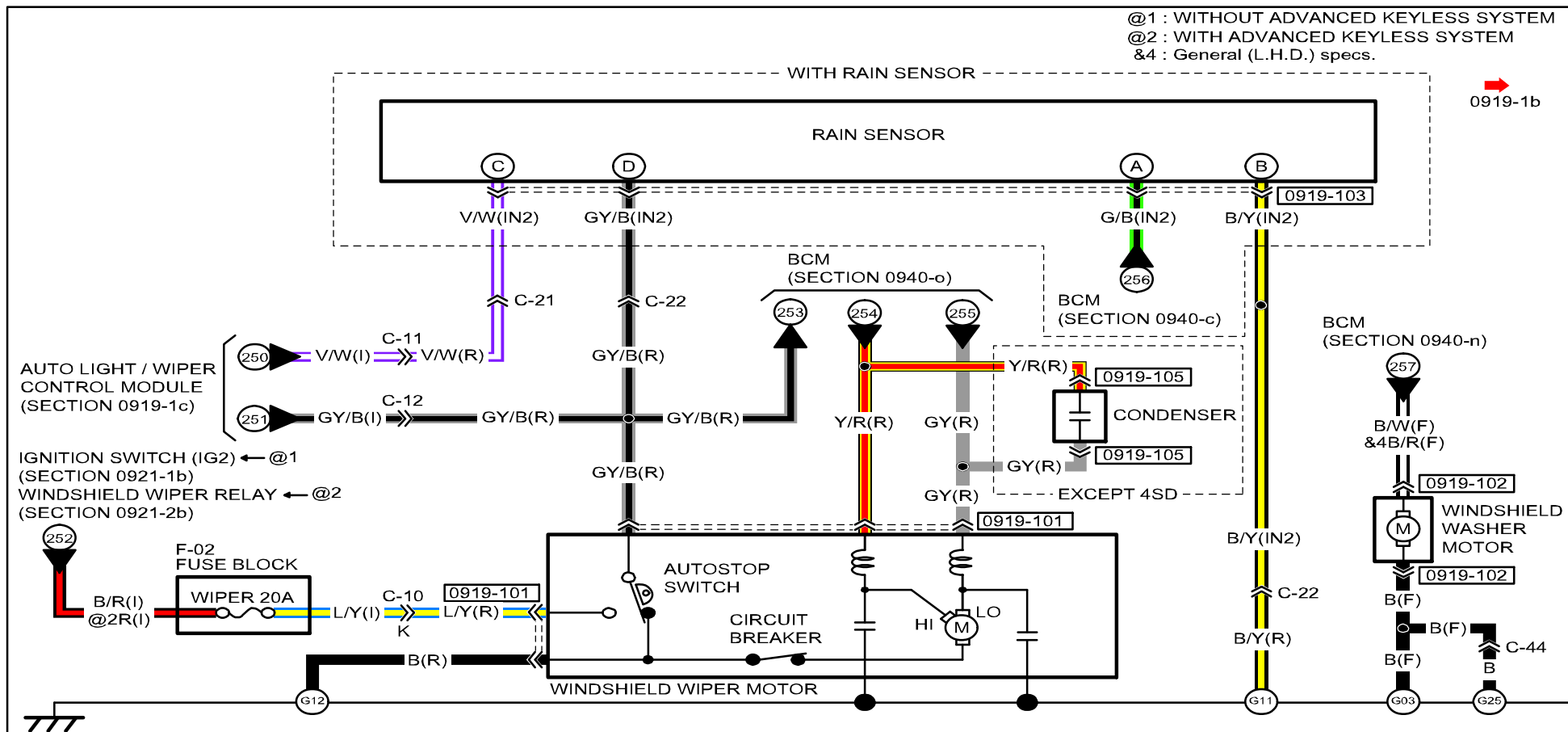

0919-1b

<p>0919-101 WINDSHIELD WIPER MOTOR</p>	<p>0919-102 WINDSHIELD WASHER MOTOR</p> <p>B : General (L.H.D.) specs.</p>	<p>0919-103 RAIN SENSOR</p>	<p>0919-105 CONDENSER</p>	Empty space for additional components
--	---	---------------------------------	-------------------------------	---------------------------------------

WINDSHIELD WIPER AND WASHER

0919-1a

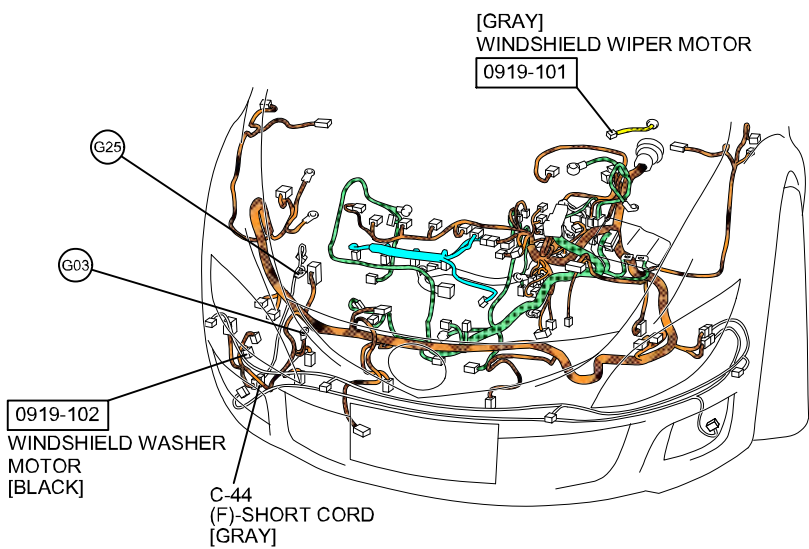

[EXCEPT MZR-CD (RF Turbo)]

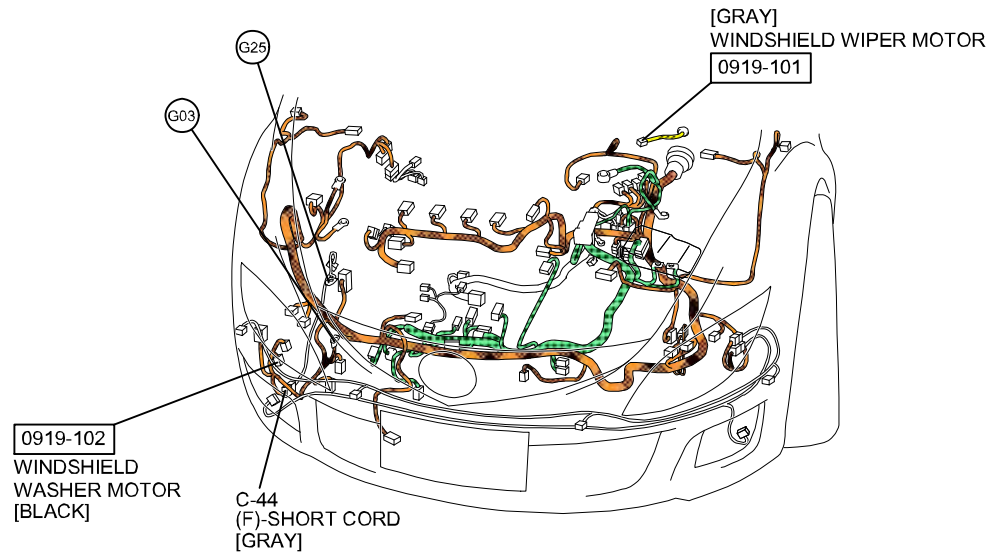

[MZR-CD (RF Turbo)]

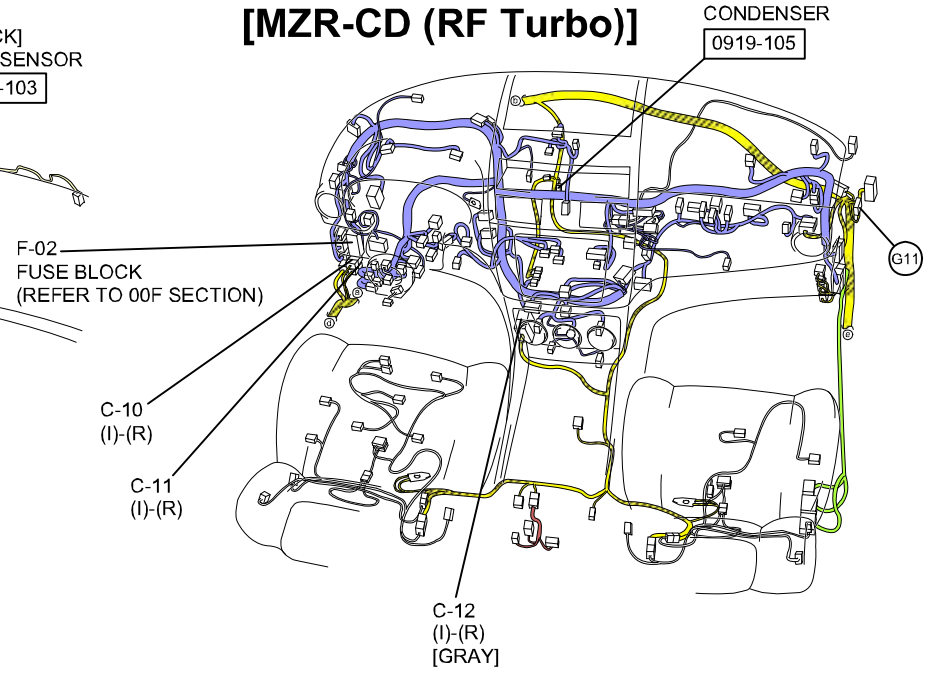
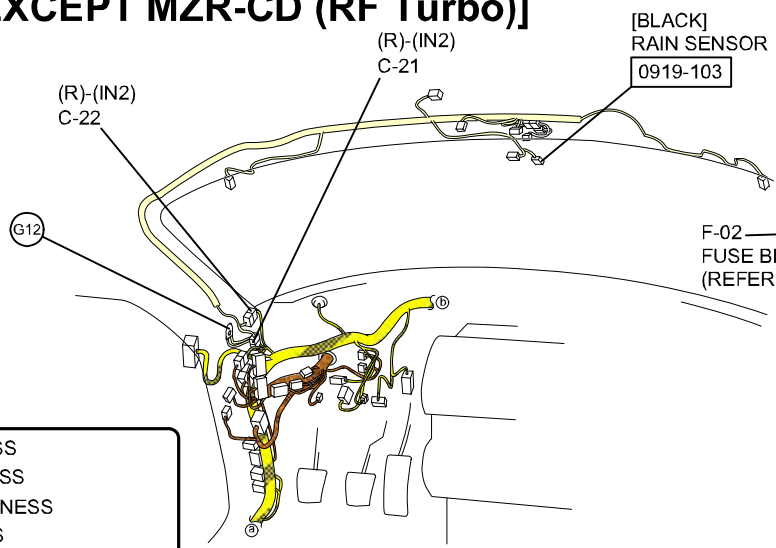

- : FRONT HARNESS
- : ENGINE HARNESS
- : INJECTION HARNESS
- : REAR HARNESS
- : REAR NO.5 HARNESS
- : INSTRUMENT PANEL HARNESS
- : FLOOR HARNESS
- : INTERIOR LIGHT NO.2 HARNESS

C-22

REAR HARNESS-INTERIOR LIGHT NO.2 HARNESS

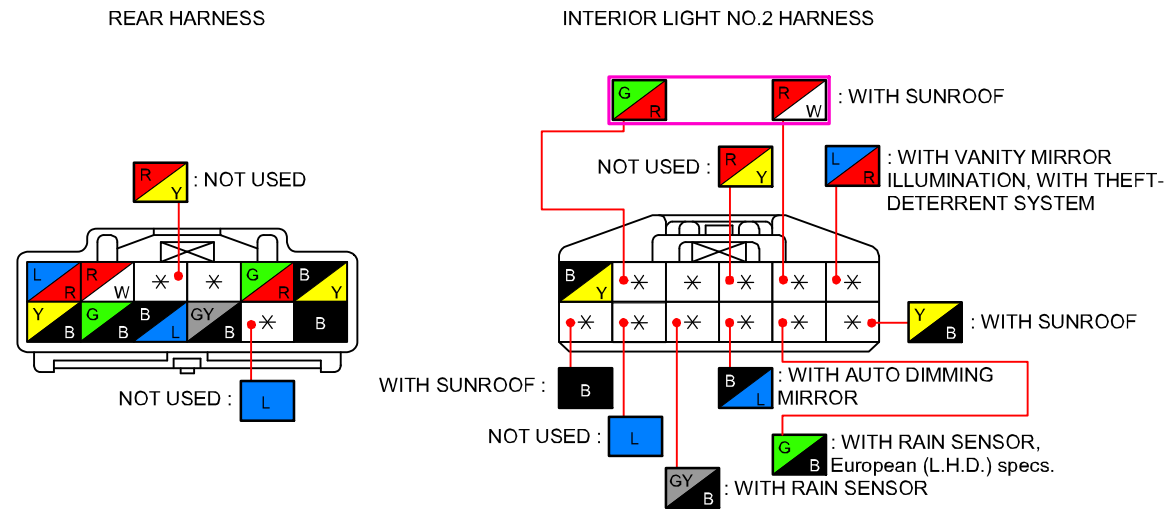

C-44

FRONT HARNESS-SHORT CORD

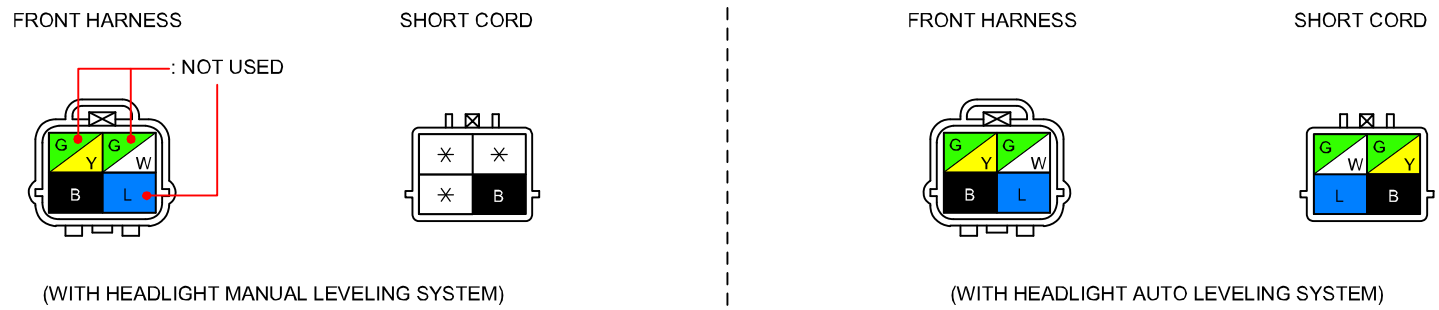

[] : WITH AUTO WIPER SYSTEM

0919-1a

0919-1c

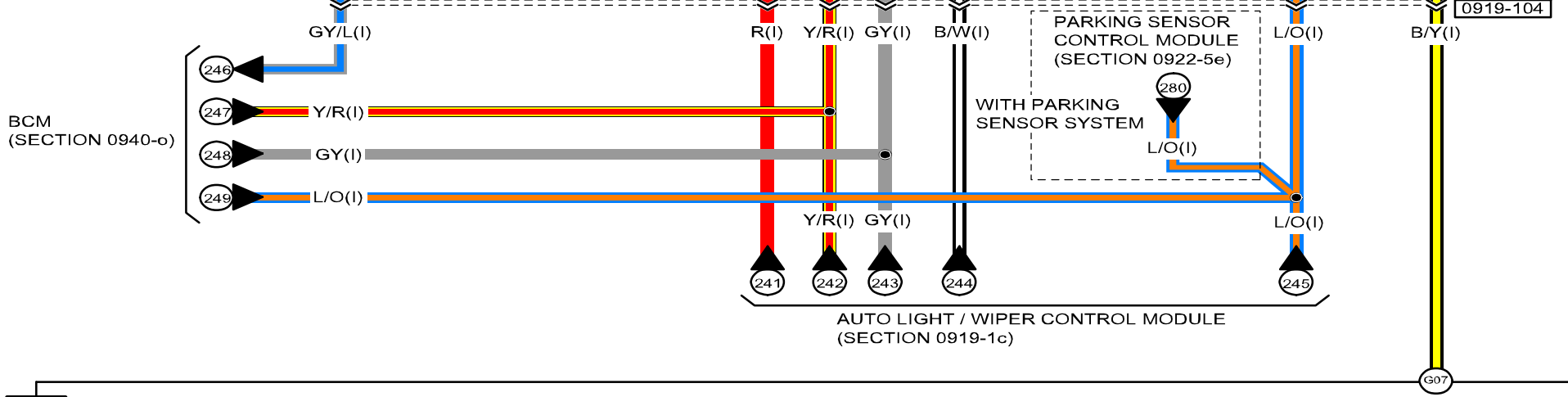
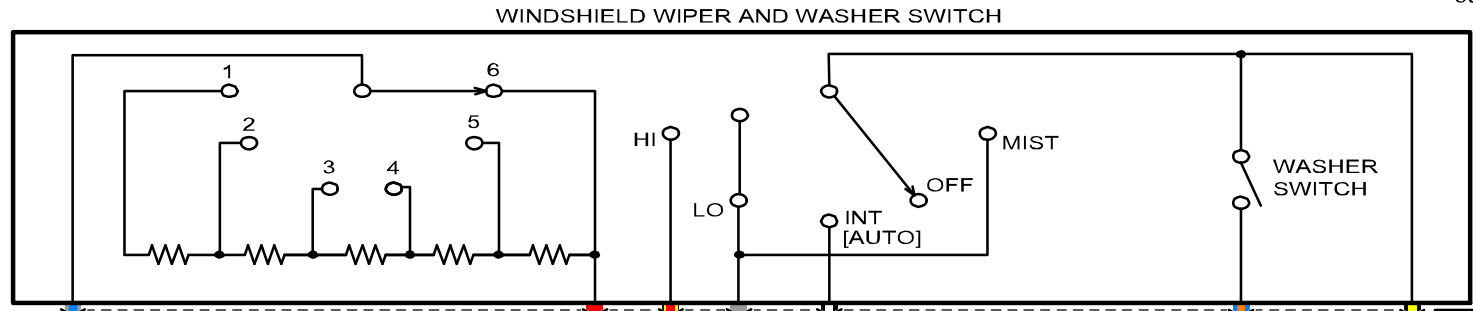



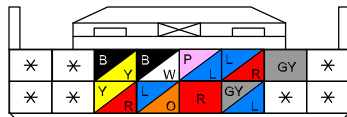

0919-104
WINDSHIELD WIPER AND WASHER SWITCH /
REAR WIPER AND WASHER SWITCH

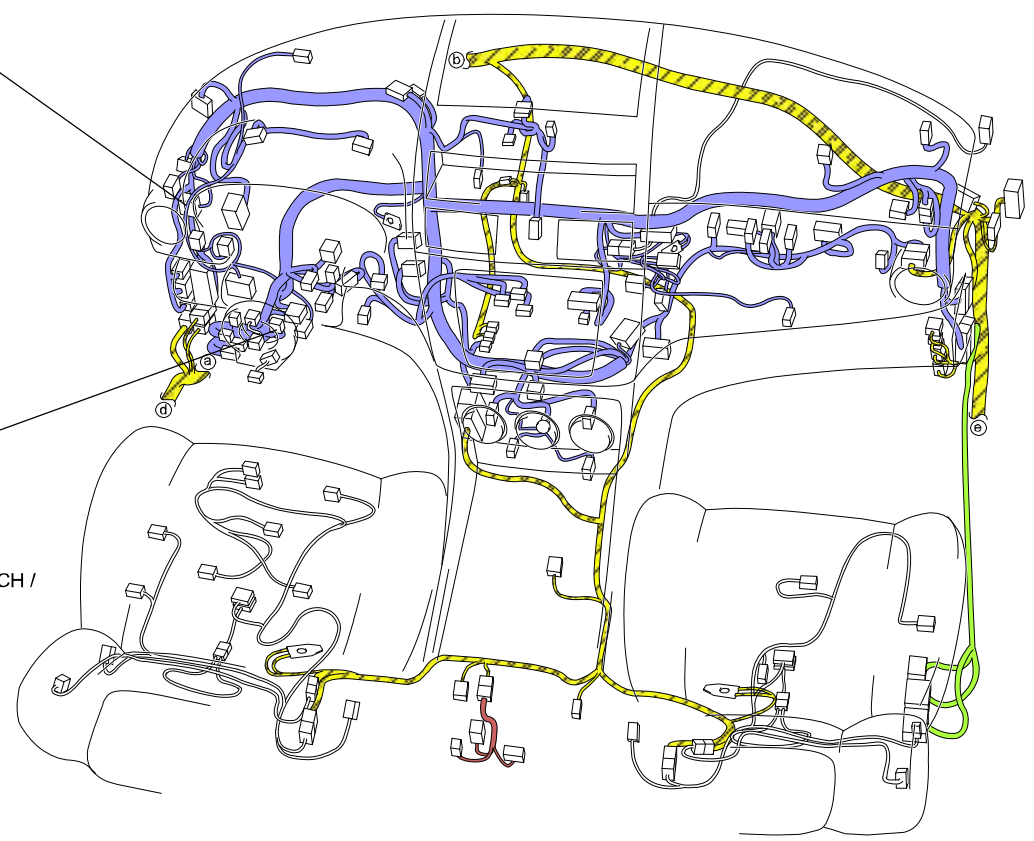

G07

0919-104
WINDSHIELD WIPER AND WASHER SWITCH /
REAR WIPER AND WASHER SWITCH



-  : REAR HARNESS
-  : REAR NO.5 HARNESS
-  : INSTRUMENT PANEL HARNESS
-  : FLOOR HARNESS

&1 : WITHOUT AUTO WIPER SYSTEM
 &2 : WITH AUTO WIPER SYSTEM

0919-1b

AUTO LIGHT / WIPER CONTROL MODULE

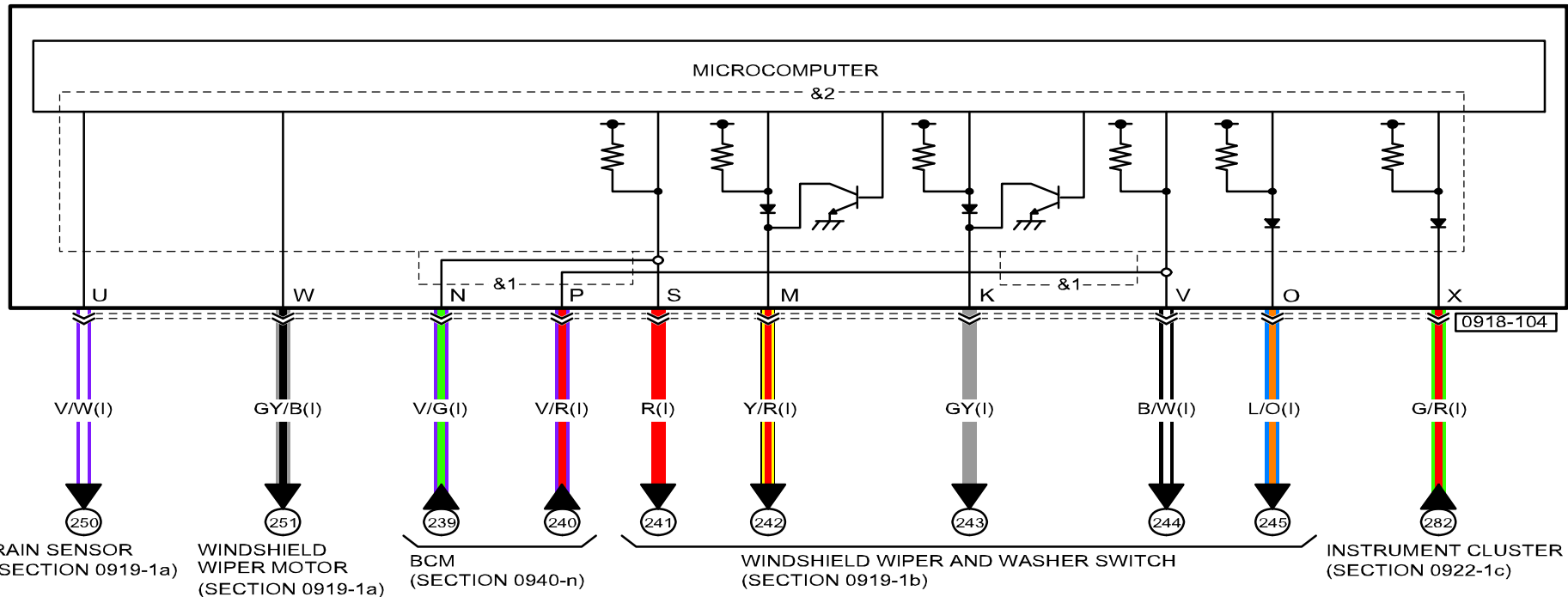



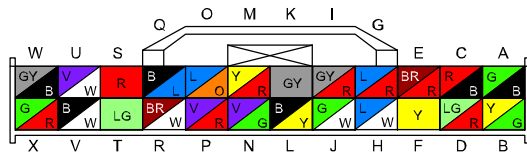

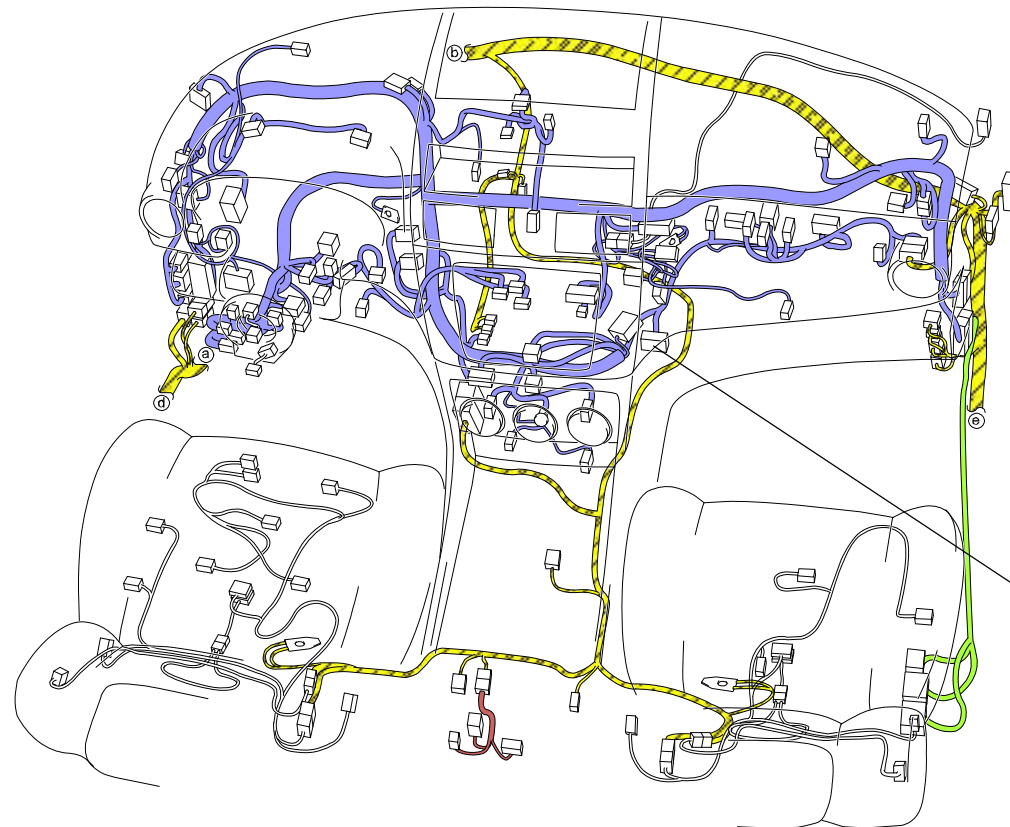
0918-104
 AUTO LIGHT / WIPER CONTROL MODULE







0918-104
AUTO LIGHT / WIPER CONTROL MODULE

-  : REAR HARNESS
-  : REAR NO.5 HARNESS
-  : INSTRUMENT PANEL HARNESS
-  : FLOOR HARNESS

REAR WIPER AND WASHER

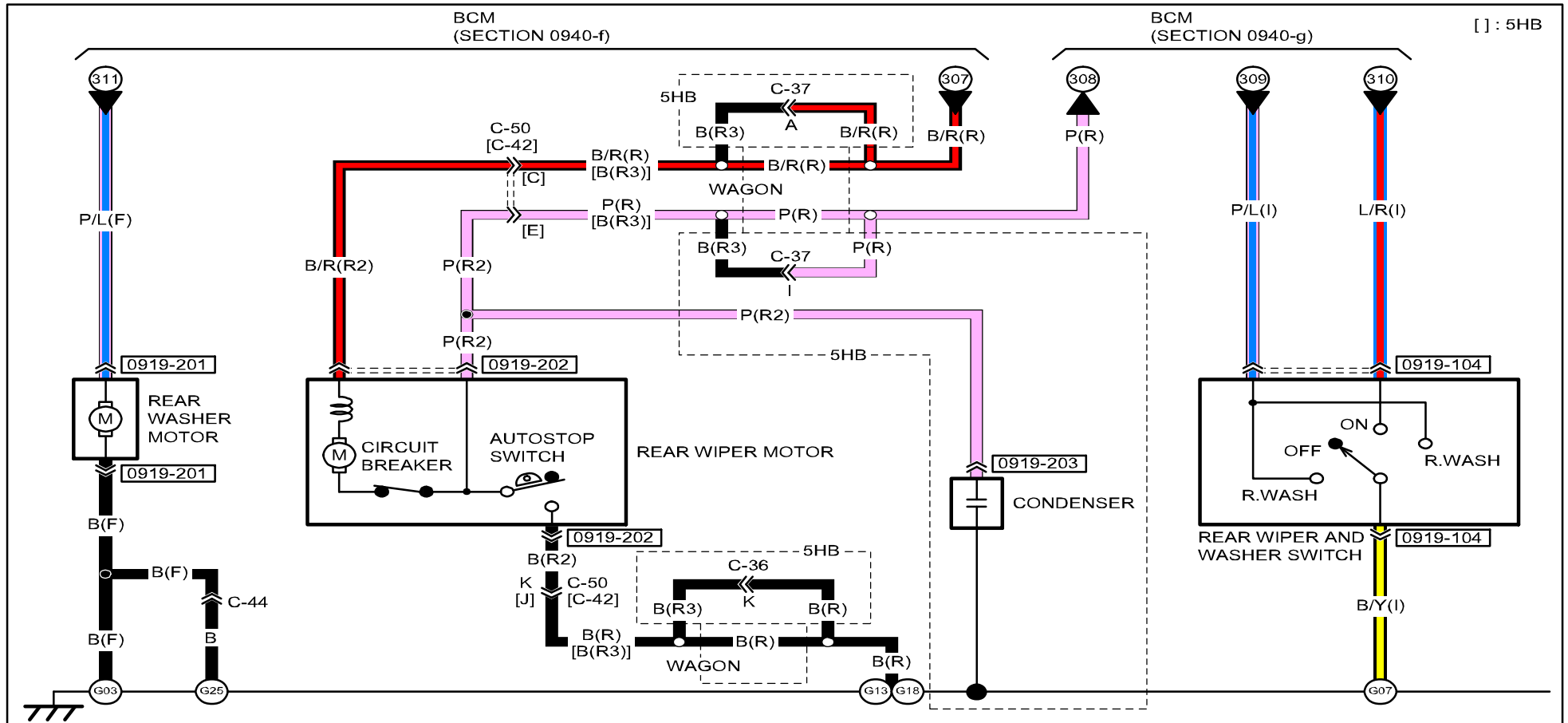
0919-2

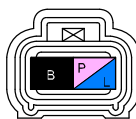
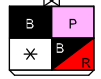

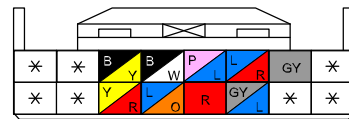
<p>0919-201 REAR WASHER MOTOR</p> 	<p>0919-202 REAR WIPER MOTOR</p> 	<p>0919-203 CONDENSER</p> 	<p>0919-104 WINDSHIELD WIPER AND WASHER SWITCH / REAR WIPER AND WASHER SWITCH</p> 		

[EXCEPT MZR-CD (RF Turbo)]

[MZR-CD (RF Turbo)]

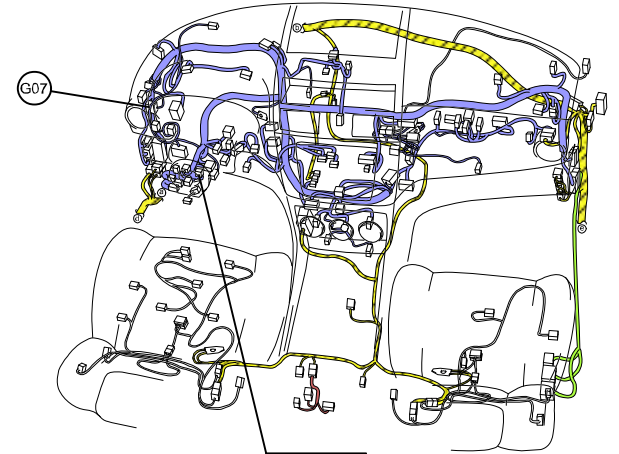
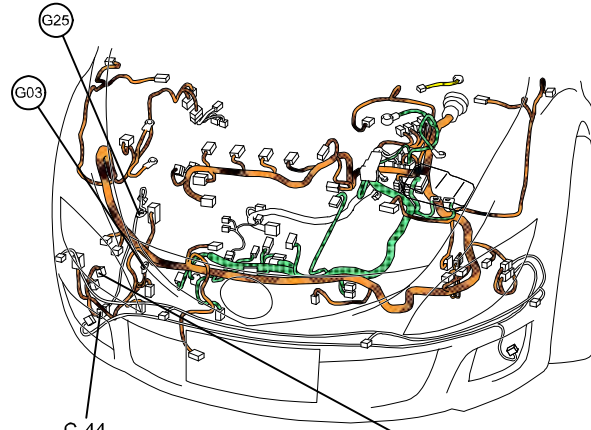
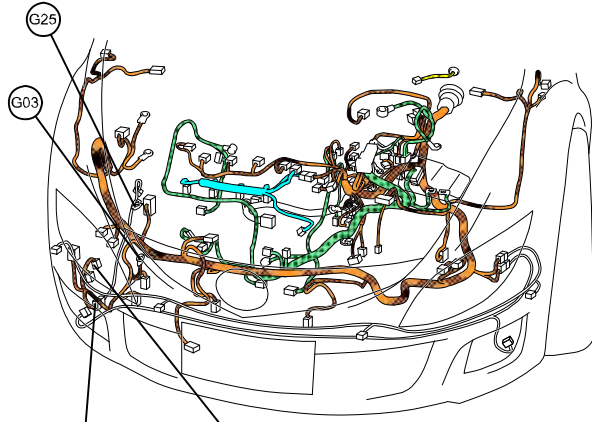

G25
G03
C-44 (F)-SHORT CORD [GRAY]
0919-201 REAR WASHER MOTOR [GRAY]

G25
G03
C-44 (F)-SHORT CORD [GRAY]
0919-201 REAR WASHER MOTOR [GRAY]

G07
0919-104 WINDSHIELD WIPER AND WASHER SWITCH / REAR WIPER AND WASHER SWITCH

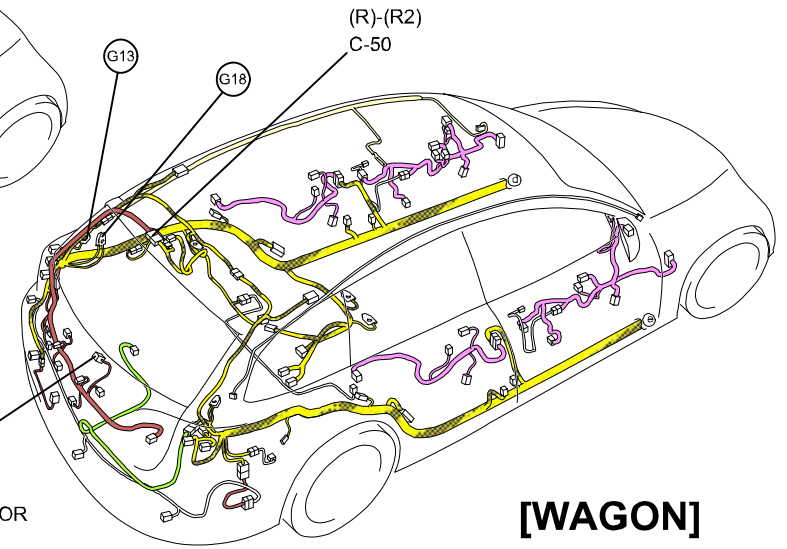
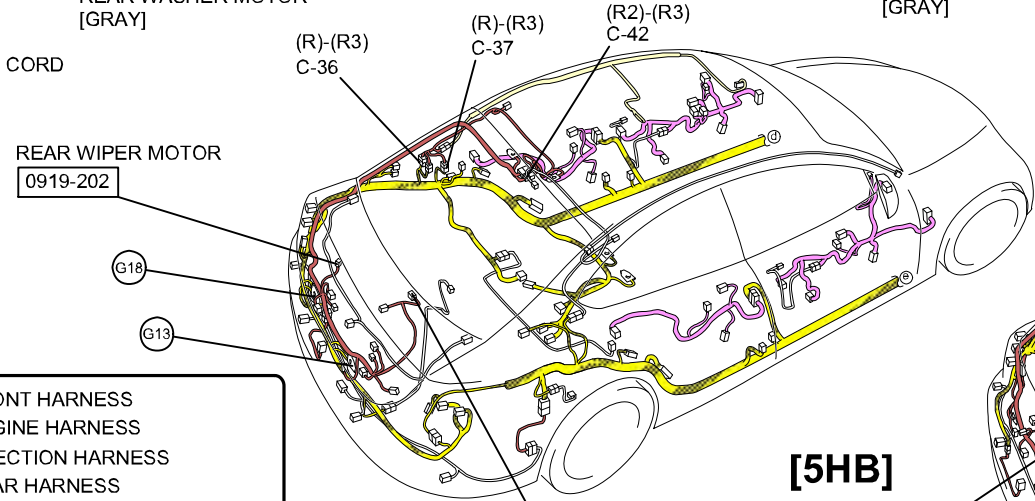













REAR WIPER MOTOR
0919-202

[5HB]

0919-202 REAR WIPER MOTOR

[WAGON]

-  : FRONT HARNESS
-  : ENGINE HARNESS
-  : INJECTION HARNESS
-  : REAR HARNESS
-  : REAR NO.2 HARNESS
-  : REAR NO.3 HARNESS
-  : REAR NO.4 HARNESS
-  : REAR NO.5 HARNESS
-  : DOOR HARNESS
-  : INTERIOR LIGHT HARNESS
-  : FLOOR HARNESS
-  : INSTRUMENT PANEL HARNESS

(R)-(R3) C-36
(R)-(R3) C-37
(R2)-(R3) C-42
G18
G13
0919-203 CONDENSER

G13
G18
(R)-(R2) C-50

REAR WIPER AND WASHER

C-36
REAR HARNESS-REAR NO.3 HARNESS

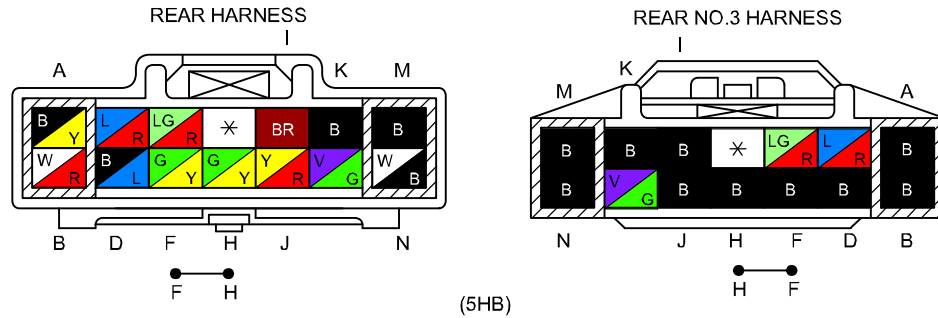

C-37
REAR HARNESS-REAR NO.3 HARNESS

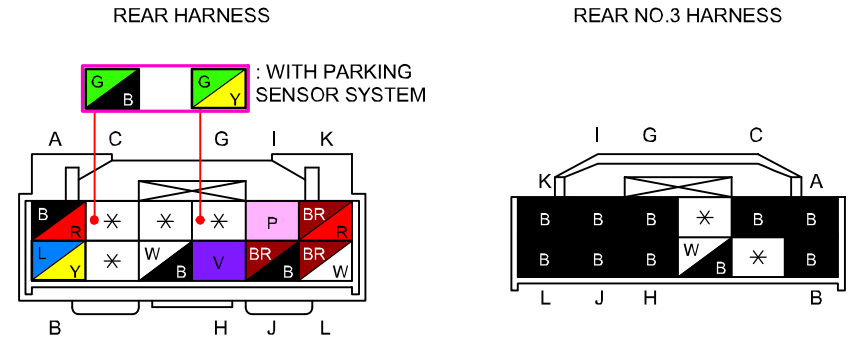

C-42
REAR NO.2 HARNESS-REAR NO.3 HARNESS

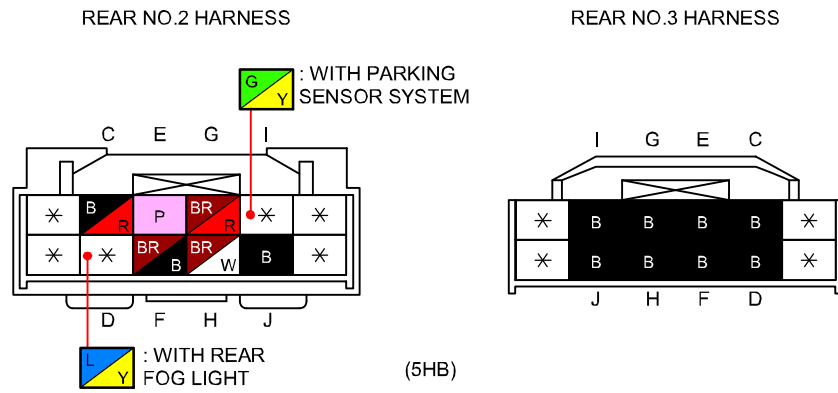

C-44
FRONT HARNESS-SHORT CORD

FRONT HARNESS

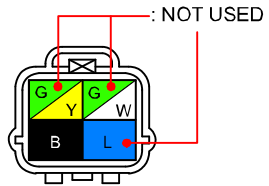

(WITH HEADLIGHT MANUAL LEVELING SYSTEM)

SHORT CORD

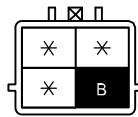

FRONT HARNESS

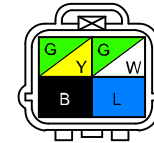

(WITH HEADLIGHT AUTO LEVELING SYSTEM)

SHORT CORD

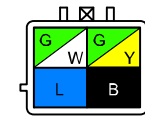

C-50
REAR HARNESS-REAR NO.2 HARNESS

REAR HARNESS

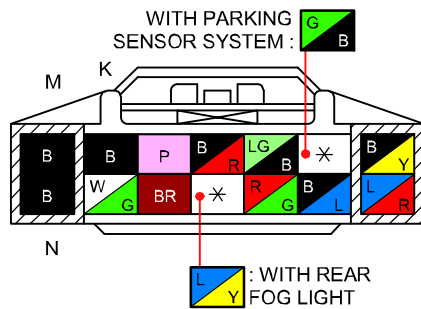

(WAGON)

REAR NO.2 HARNESS

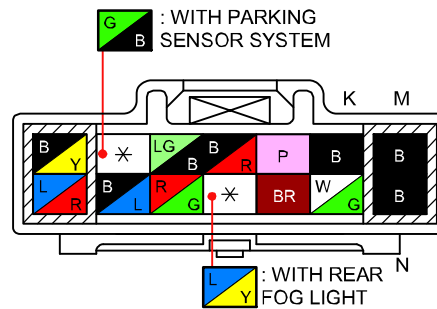

HEADLIGHT CLEANER

0919-3

&5 : MZR-CD (RF Turbo)

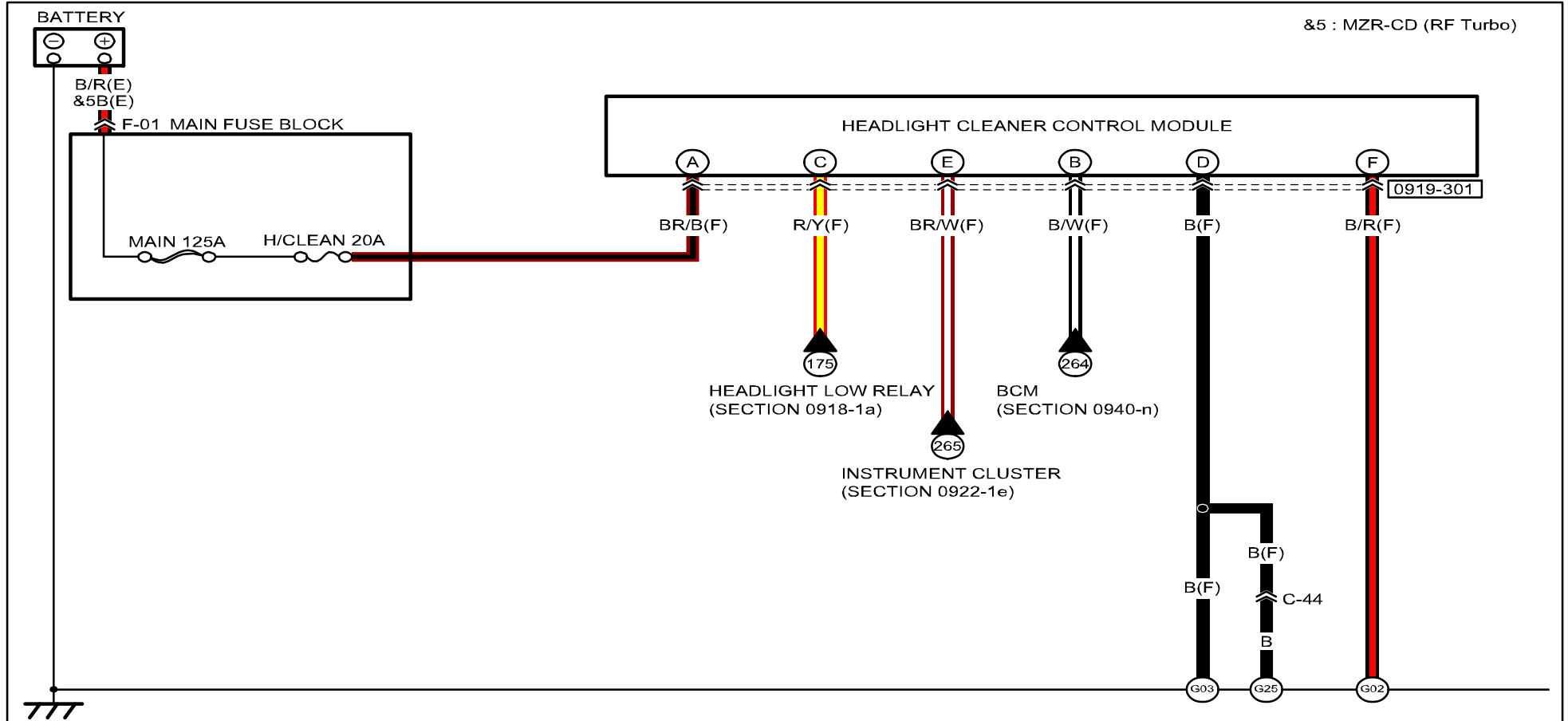

<p>0919-301 HEADLIGHT CLEANER CONTROL MODULE</p>					

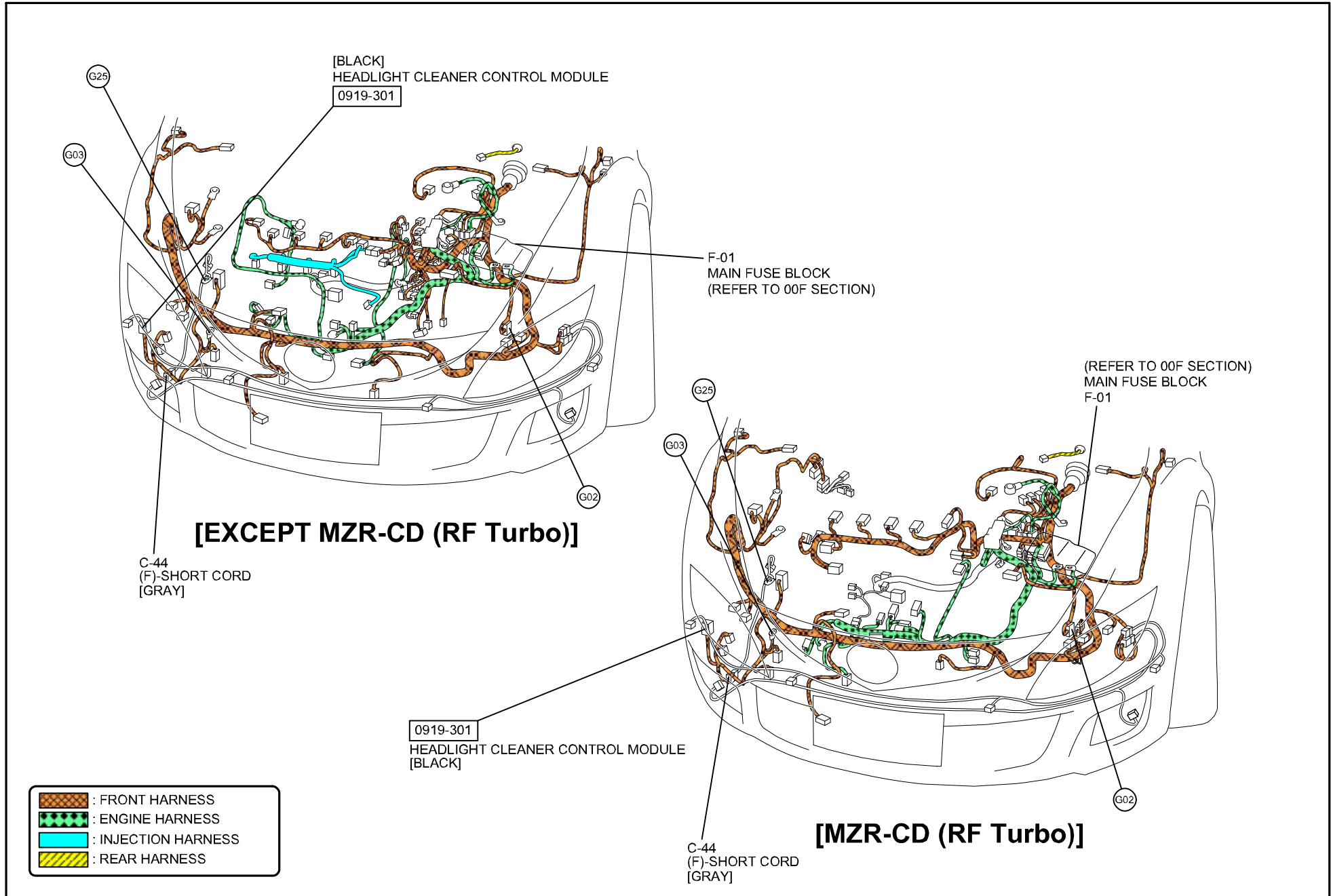

C-44
FRONT HARNESS-SHORT CORD

FRONT HARNESS

SHORT CORD

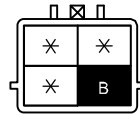
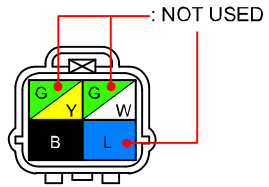

(WITH HEADLIGHT MANUAL LEVELING SYSTEM)

FRONT HARNESS

SHORT CORD

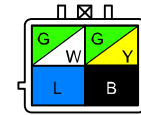
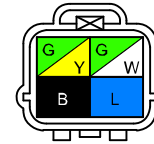



(WITH HEADLIGHT AUTO LEVELING SYSTEM)

ACCESSORY SOCKET / CIGARETTE LIGHTER

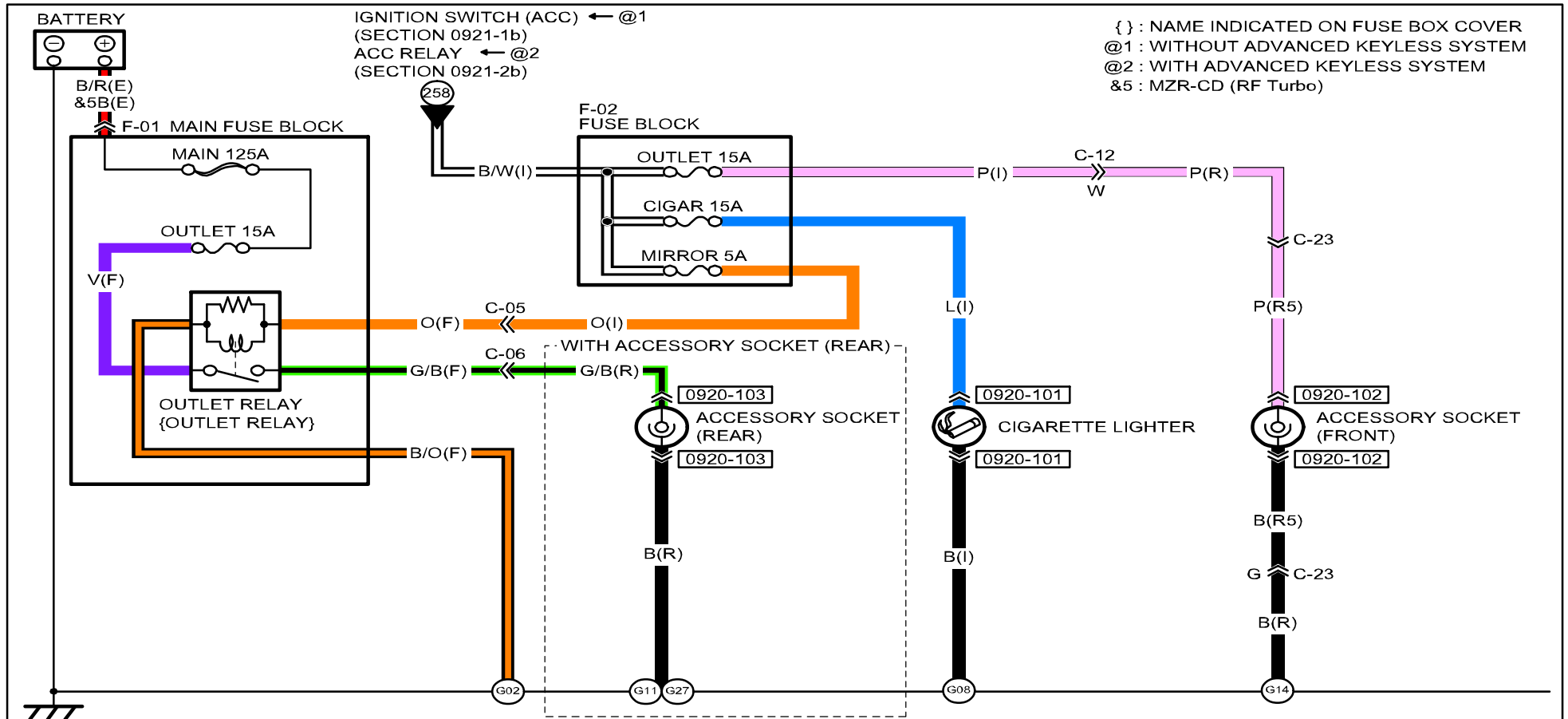
0920-1



<p>0920-101 CIGARETTE LIGHTER</p> 	<p>0920-102 ACCESSORY SOCKET (FRONT)</p> 	<p>0920-103 ACCESSORY SOCKET (REAR)</p> 	

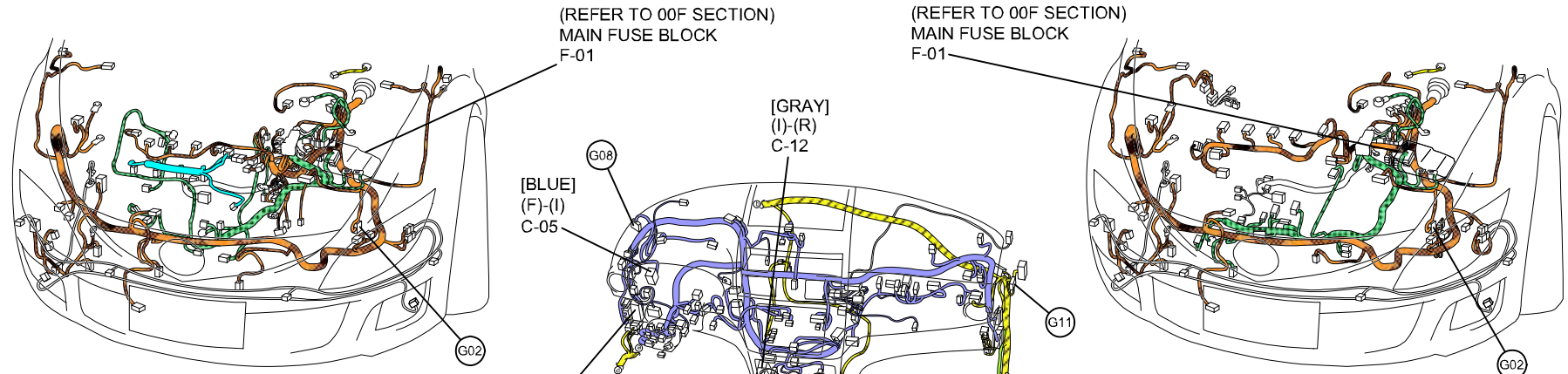

[EXCEPT MZR-CD (RF Turbo)]

[MZR-CD (RF Turbo)]

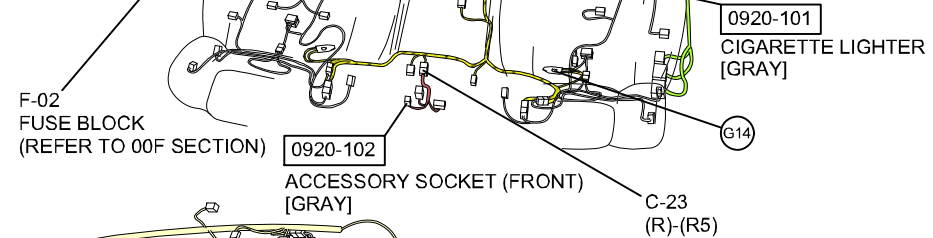

- : FRONT HARNESS
- : ENGINE HARNESS
- : INJECTION HARNESS
- : REAR HARNESS
- : REAR NO.2 HARNESS
- : REAR NO.4 HARNESS
- : REAR NO.5 HARNESS
- : DOOR HARNESS
- : INTERIOR LIGHT HARNESS
- : INTERIOR LIGHT NO.2 HARNESS
- : FLOOR HARNESS
- : INSTRUMENT PANEL HARNESS

C-05
FRONT HARNESS-INSTRUMENT PANEL HARNESS

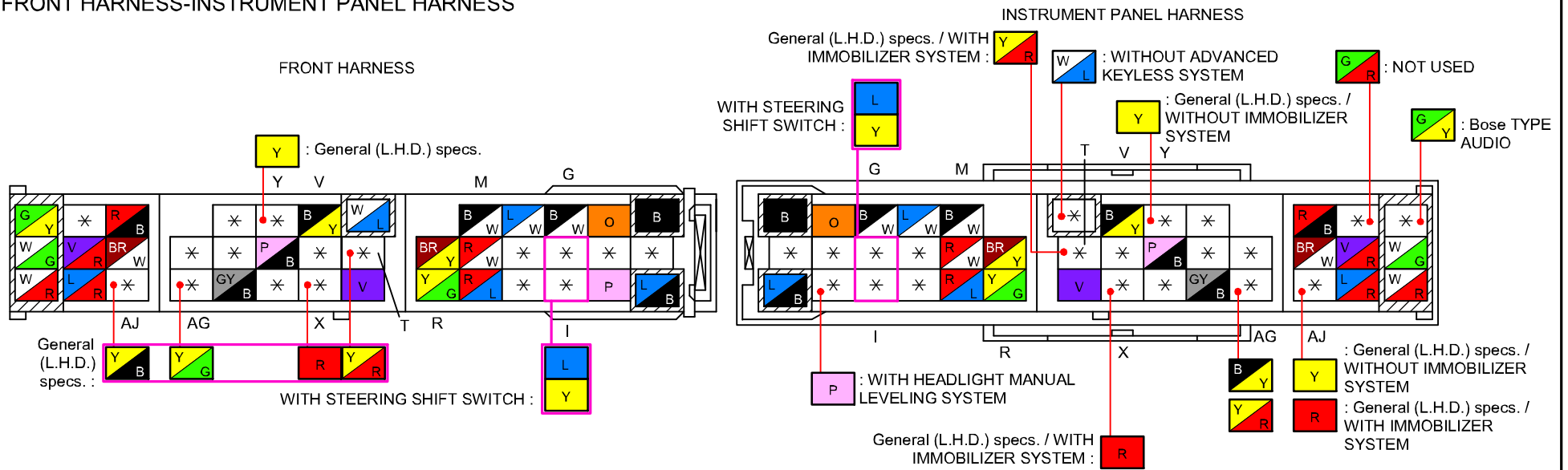

C-06
FRONT HARNESS-REAR HARNESS

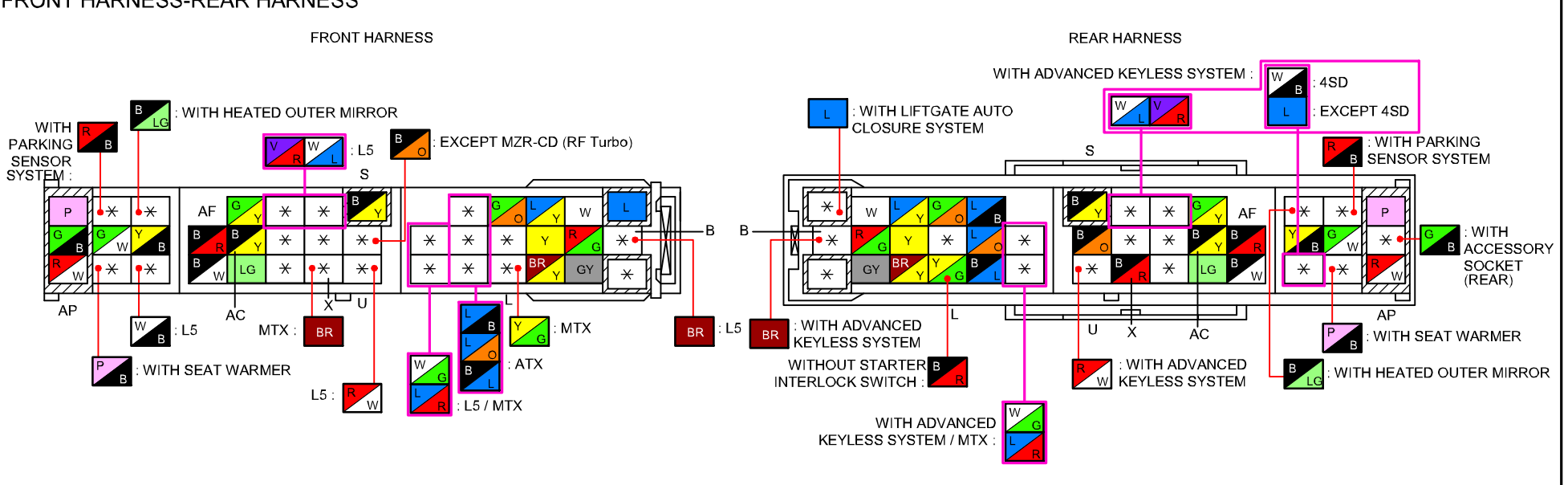

C-12
INSTRUMENT PANEL HARNESS-REAR HARNESS

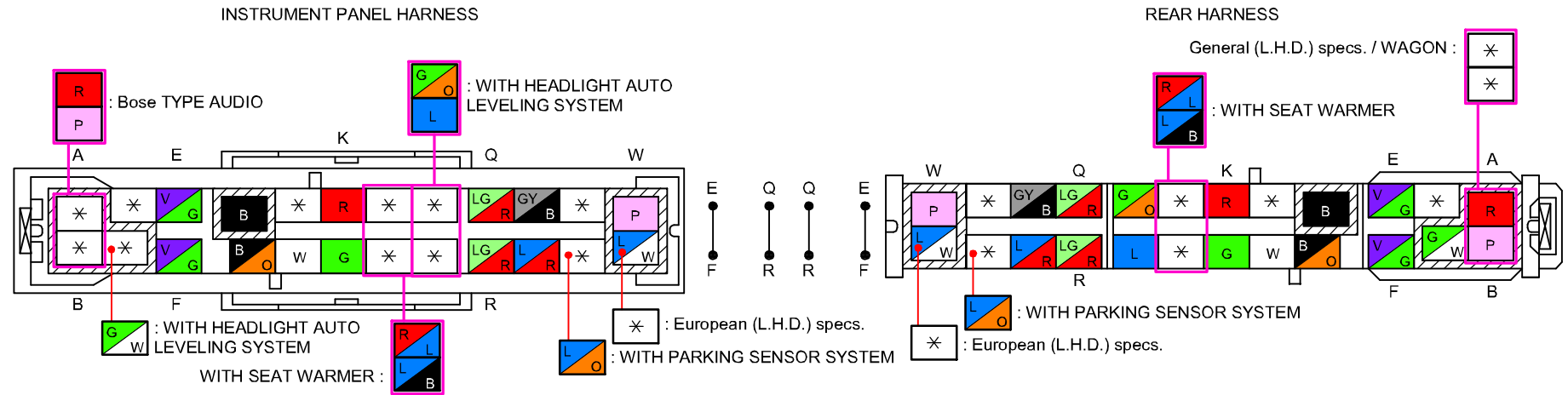

C-23
REAR HARNESS-REAR NO.5 HARNESS

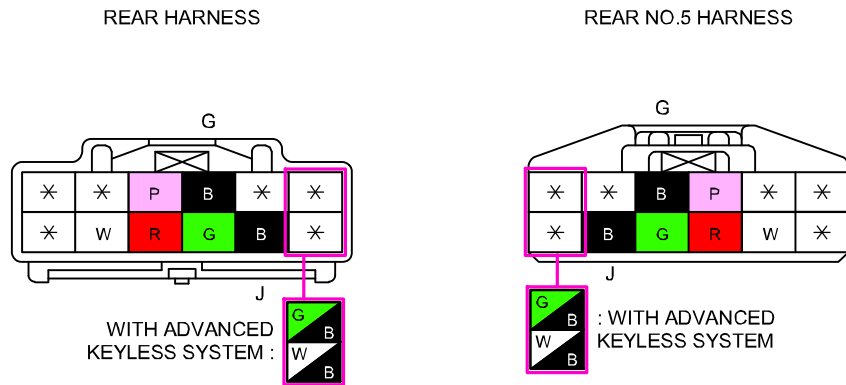

AUDIO SYSTEM (EXCEPT Bose® TYPE AUDIO)

0920-2a

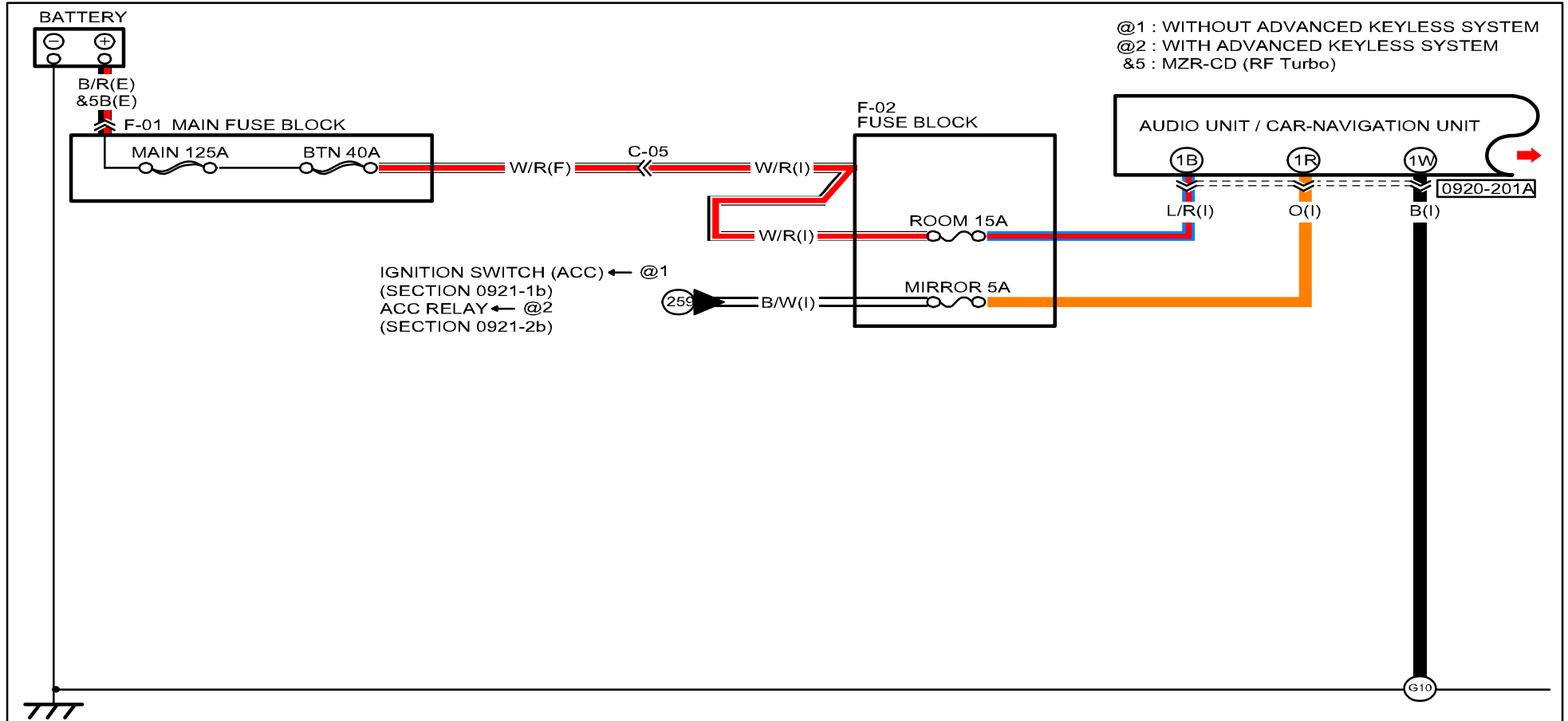

0920-201A
AUDIO UNIT / CAR-NAVIGATION UNIT

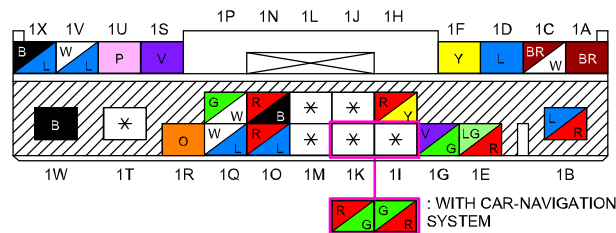

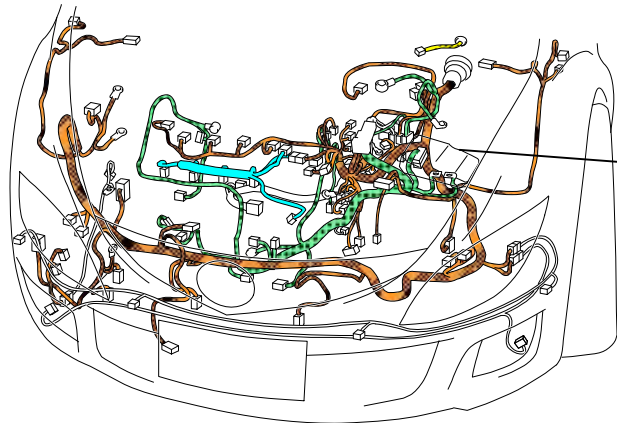

F-01
MAIN FUSE BLOCK
(REFER TO 00F SECTION)

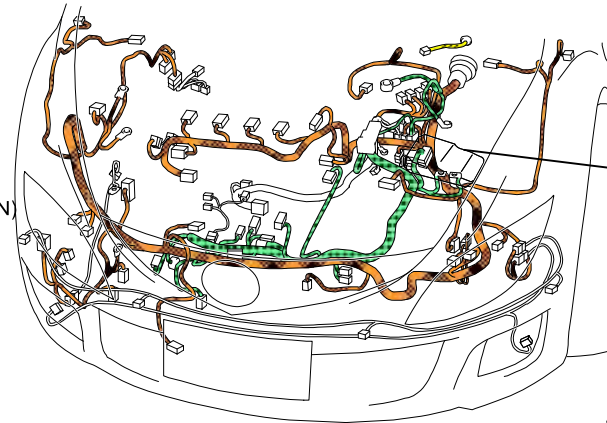

F-01
MAIN FUSE BLOCK
(REFER TO 00F SECTION)

[EXCEPT MZR-CD (RF Turbo)]

[MZR-CD (RF Turbo)]

AUDIO UNIT /
CAR-NAVIGATION UNIT
0920-201A

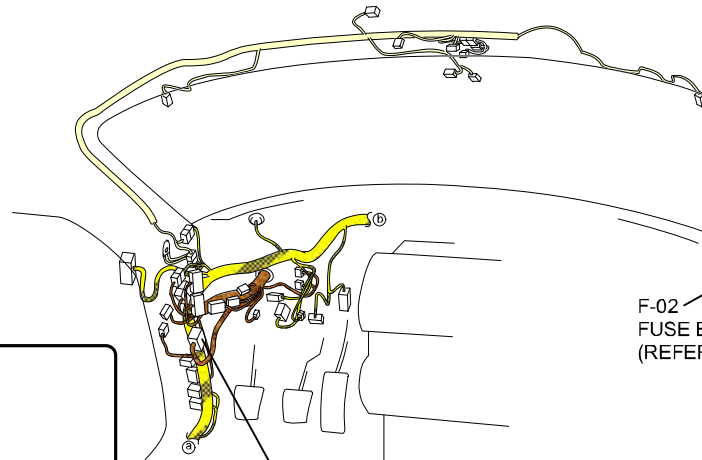







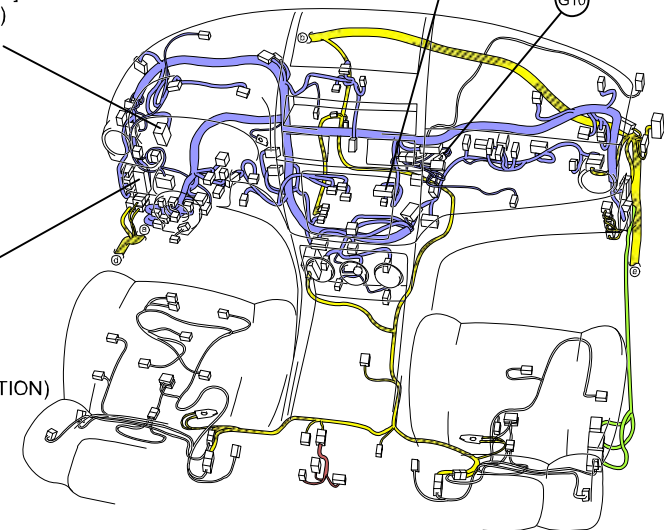

C-05
(F)-(I)
[BLUE]

[BLUE]
(F)-(I)
C-05

F-02
FUSE BLOCK
(REFER TO 00F SECTION)



G10

-  : FRONT HARNESS
-  : ENGINE HARNESS
-  : INJECTION HARNESS
-  : REAR HARNESS
-  : REAR NO.5 HARNESS
-  : INSTRUMENT PANEL HARNESS
-  : FLOOR HARNESS
-  : INTERIOR LIGHT NO.2 HARNESS

C-05

FRONT HARNESS-INSTRUMENT PANEL HARNESS

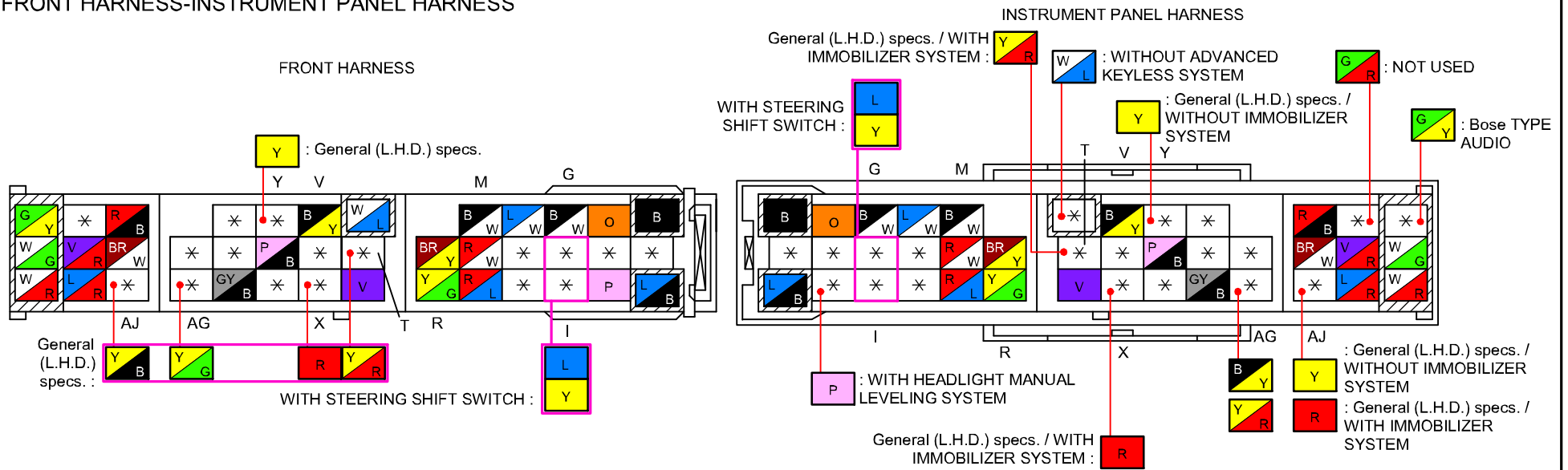

: WITH HANDS-FREE TELEPHONE (HF/TEL) SYSTEM,
WITH CAR-NAVIGATION SYSTEM
&3 : VOICE RECOGNITION/HANDS FREE, MUTE

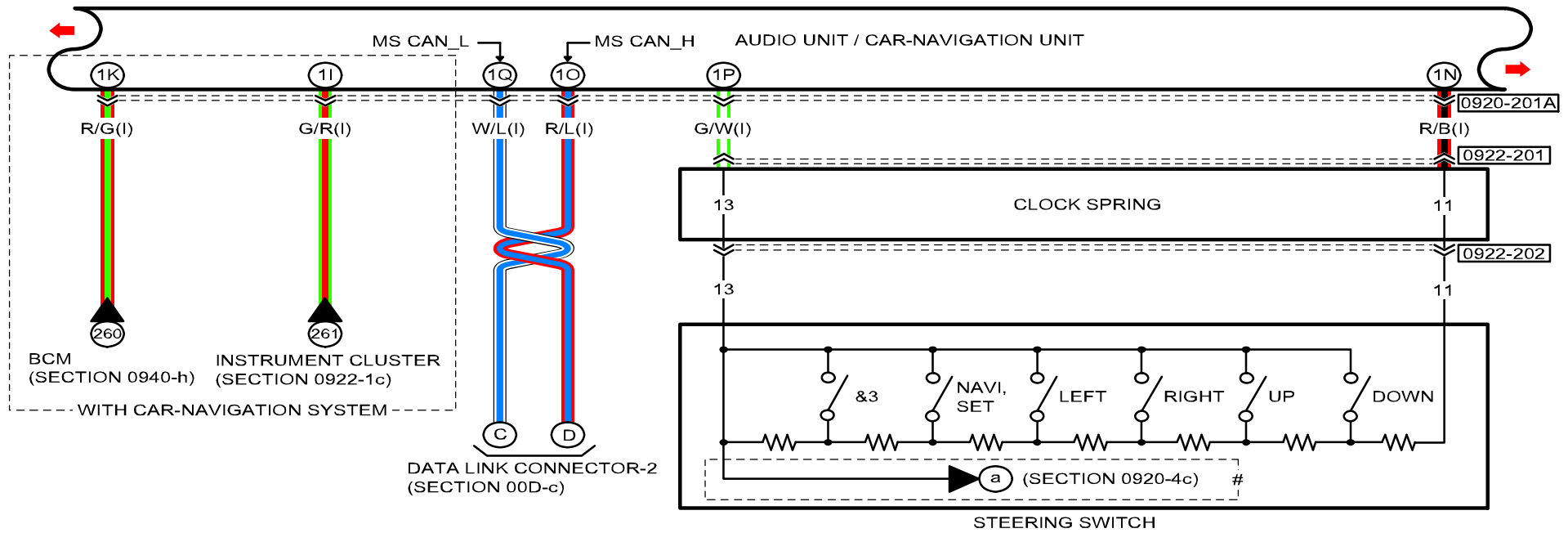

0920-201A
AUDIO UNIT / CAR-NAVIGATION UNIT

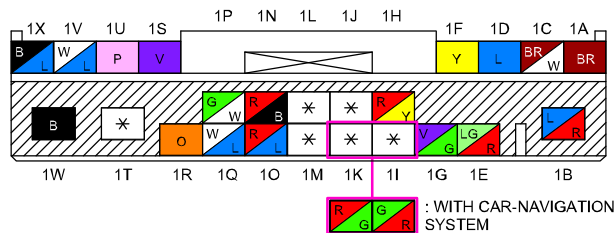

0922-201
CLOCK SPRING

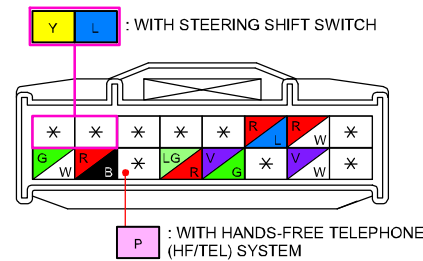

0922-202
CRUISE CONTROL SWITCH /
UP SWITCH / DOWN SWITCH /
STEERING SWITCH ILLUMINATION /
UP SWITCH ILLUMINATION /
DOWN SWITCH ILLUMINATION /
CRUISE CONTROL SWITCH ILLUMINATION /
STEERING SWITCH /
CLOCK SPRING

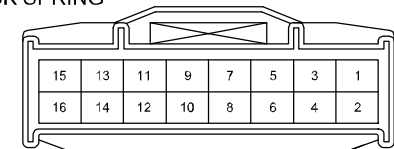

TERMINALS OF THIS CONNECTOR
ARE INDICATED BY NUMBERS.

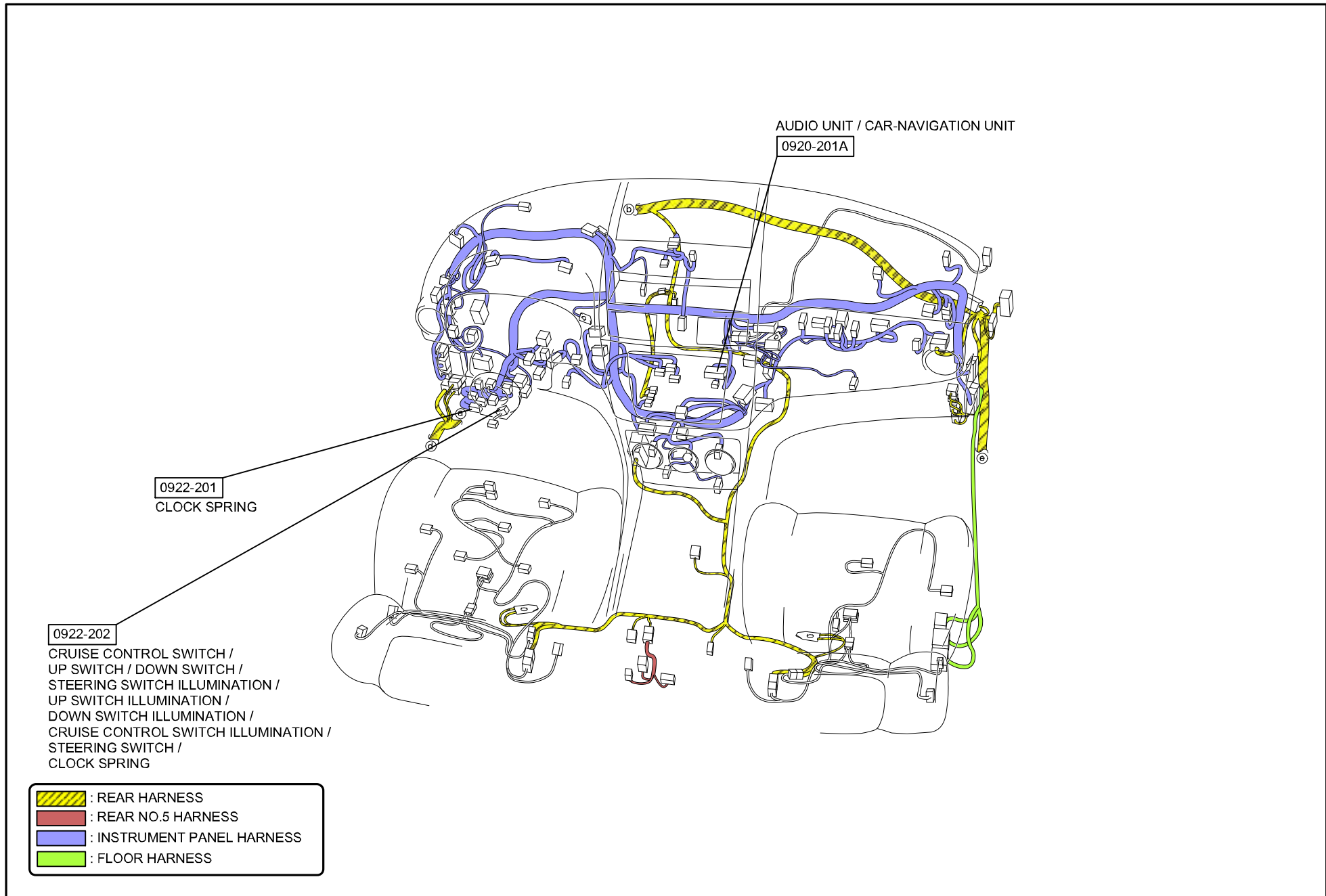

@1 : WITHOUT ADVANCED KEYLESS SYSTEM
 @2 : WITH ADVANCED KEYLESS SYSTEM

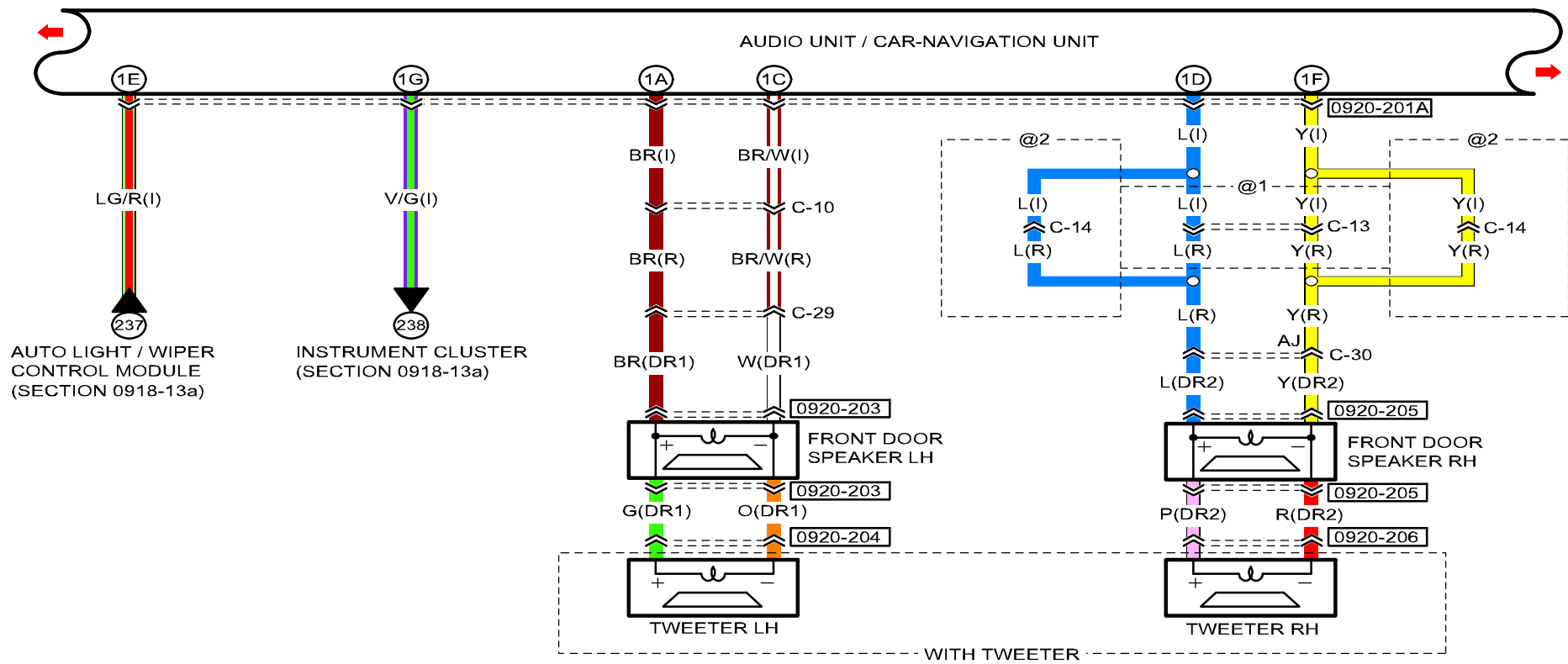

0920-201A
 AUDIO UNIT / CAR-NAVIGATION UNIT

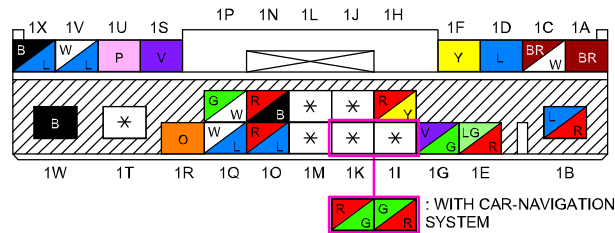

0920-203
 FRONT DOOR SPEAKER LH

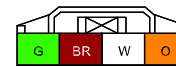

0920-205
 FRONT DOOR SPEAKER RH

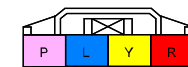

0920-204
 TWEETER LH



0920-206
 TWEETER RH



AUDIO SYSTEM (EXCEPT Bose® TYPE AUDIO)

0920-2c

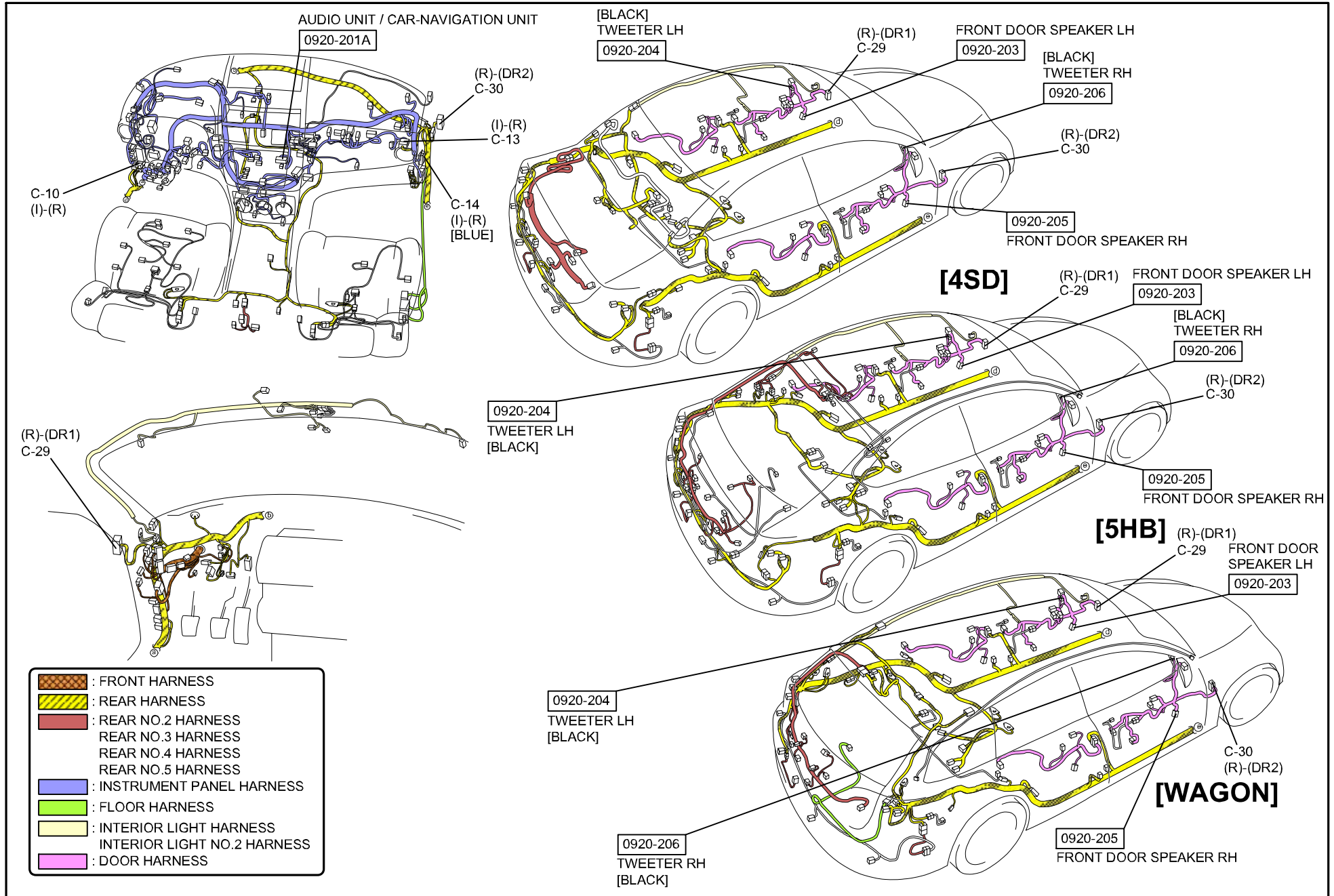

C-10
INSTRUMENT PANEL HARNESS-REAR HARNESS

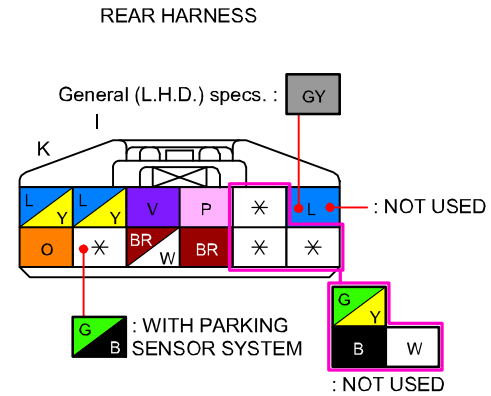
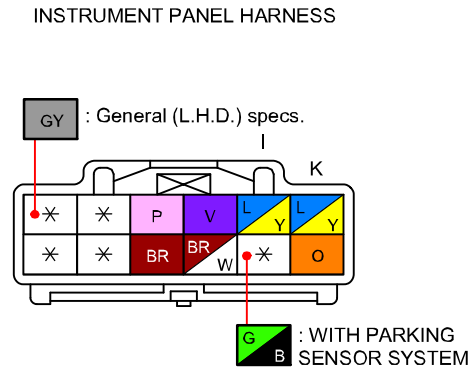

C-13
INSTRUMENT PANEL HARNESS-REAR HARNESS

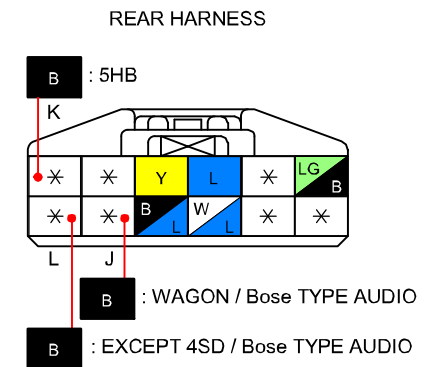
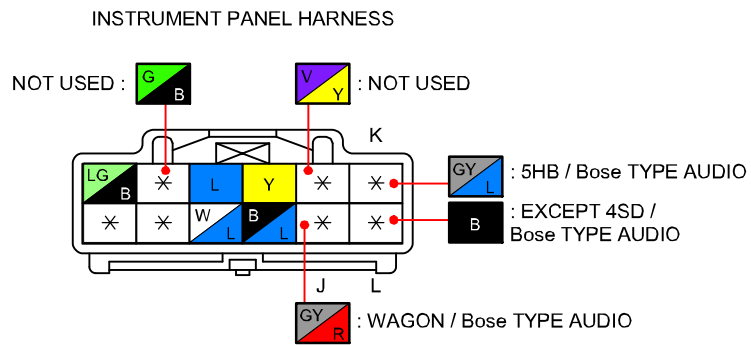

(WITHOUT ADVANCED KEYLESS SYSTEM)

C-14

INSTRUMENT PANEL HARNESS-REAR HARNESS

INSTRUMENT PANEL HARNESS

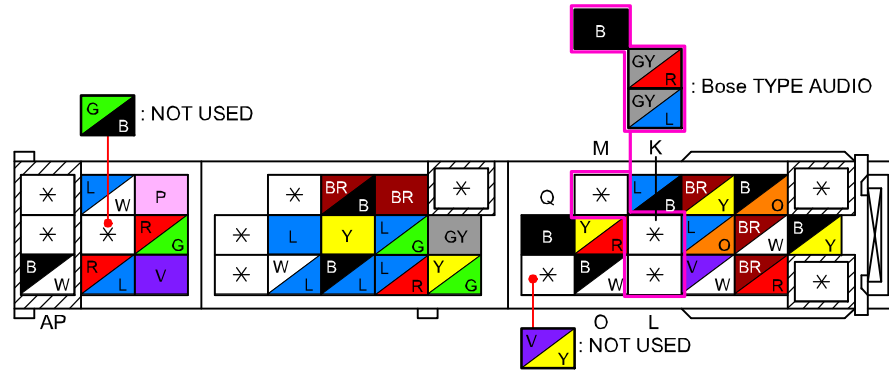

(WITH ADVANCED KEYLESS SYSTEM)

REAR HARNESS

European (L.H.D.) specs. / WAGON : B B : 5HB, European (L.H.D.) specs. / WAGON

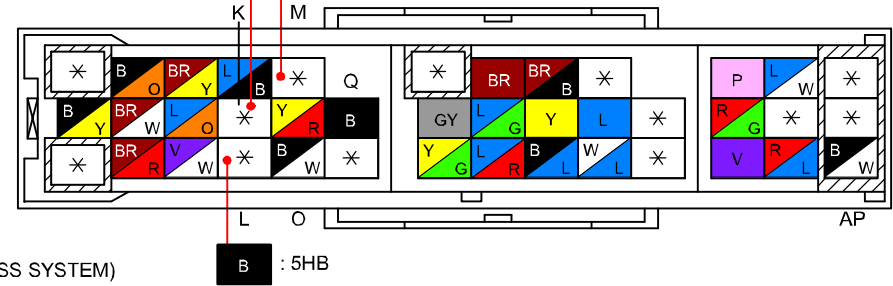

@1 : WITHOUT ADVANCED KEYLESS SYSTEM
 @2 : WITH ADVANCED KEYLESS SYSTEM

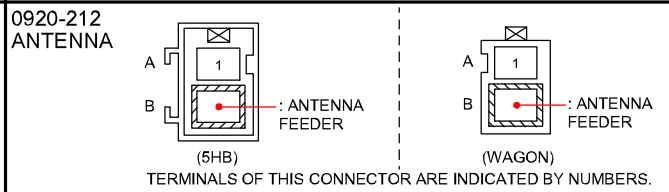
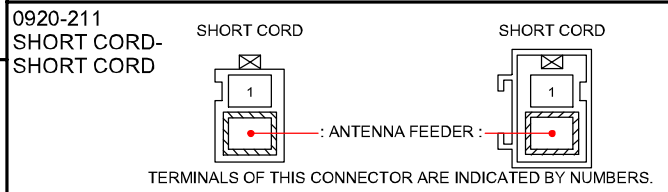
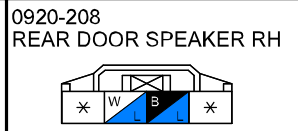
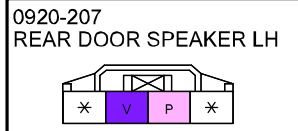
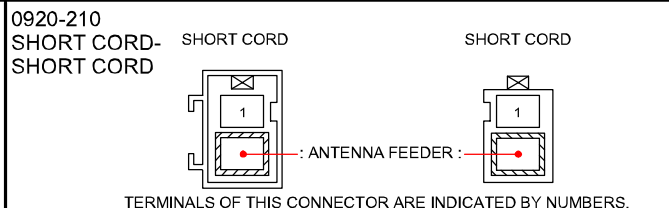
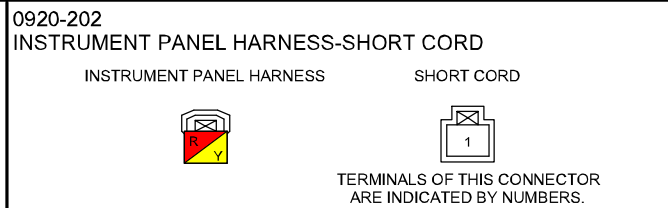
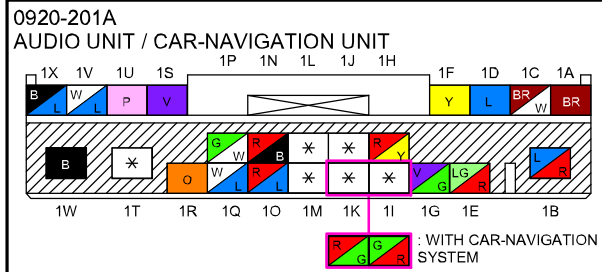
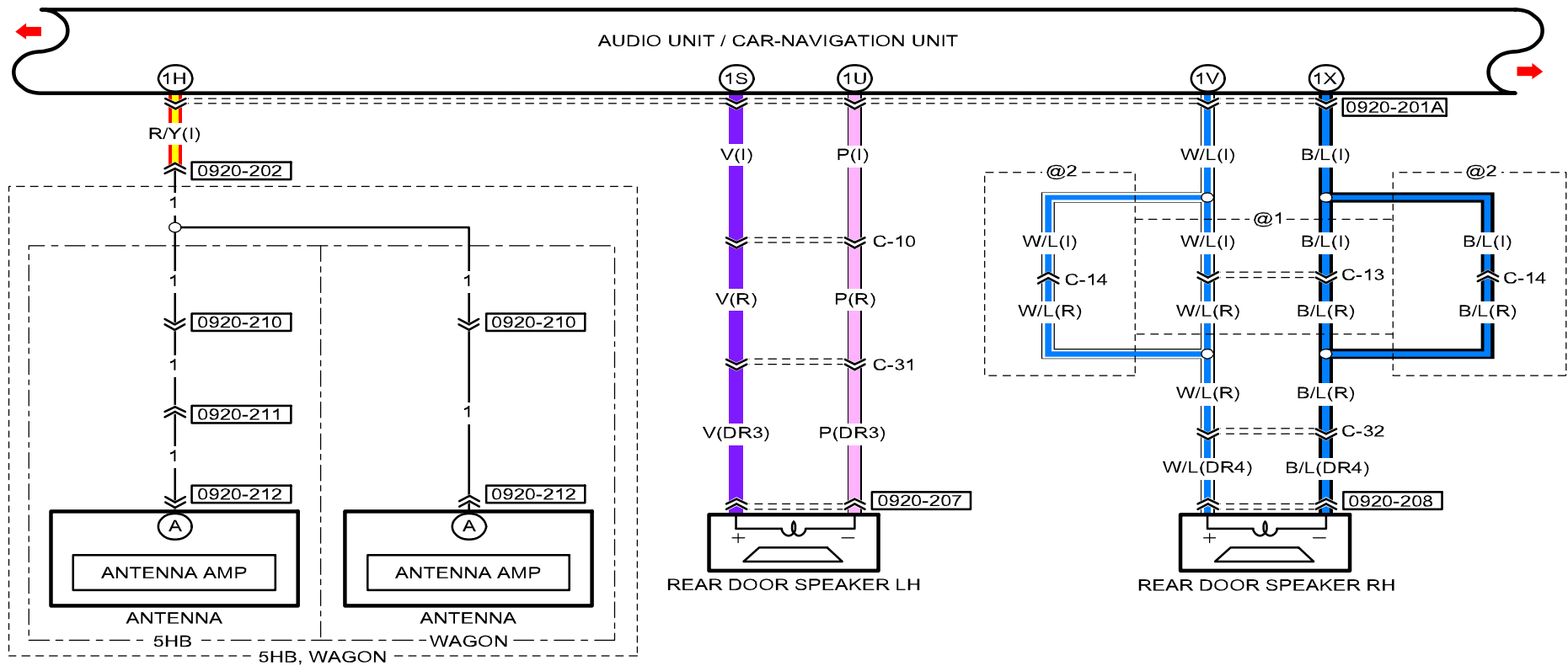

AUDIO SYSTEM (EXCEPT Bose® TYPE AUDIO)

0920-2d

- : INSTRUMENT PANEL HARNESS
- : REAR HARNESS
- : REAR NO.2 HARNESS
- : REAR NO.3 HARNESS
- : REAR NO.4 HARNESS
- : REAR NO.5 HARNESS
- : DOOR HARNESS
- : INTERIOR LIGHT HARNESS
- : FLOOR HARNESS

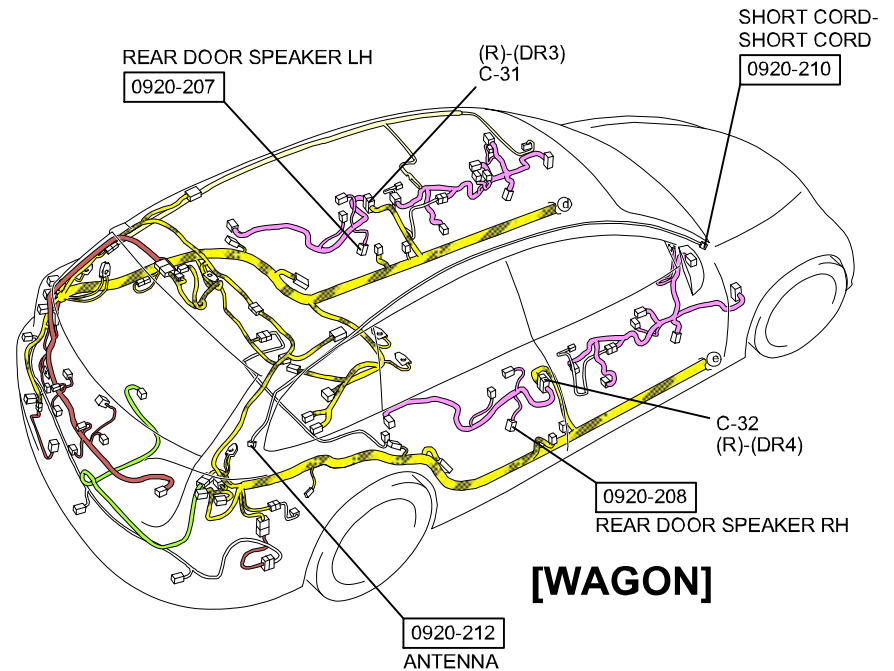
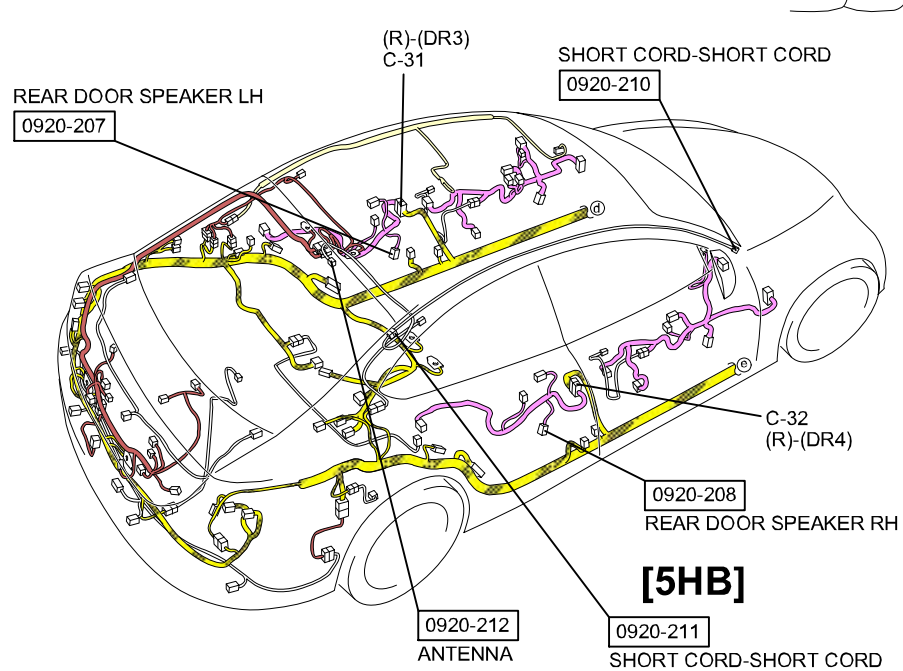
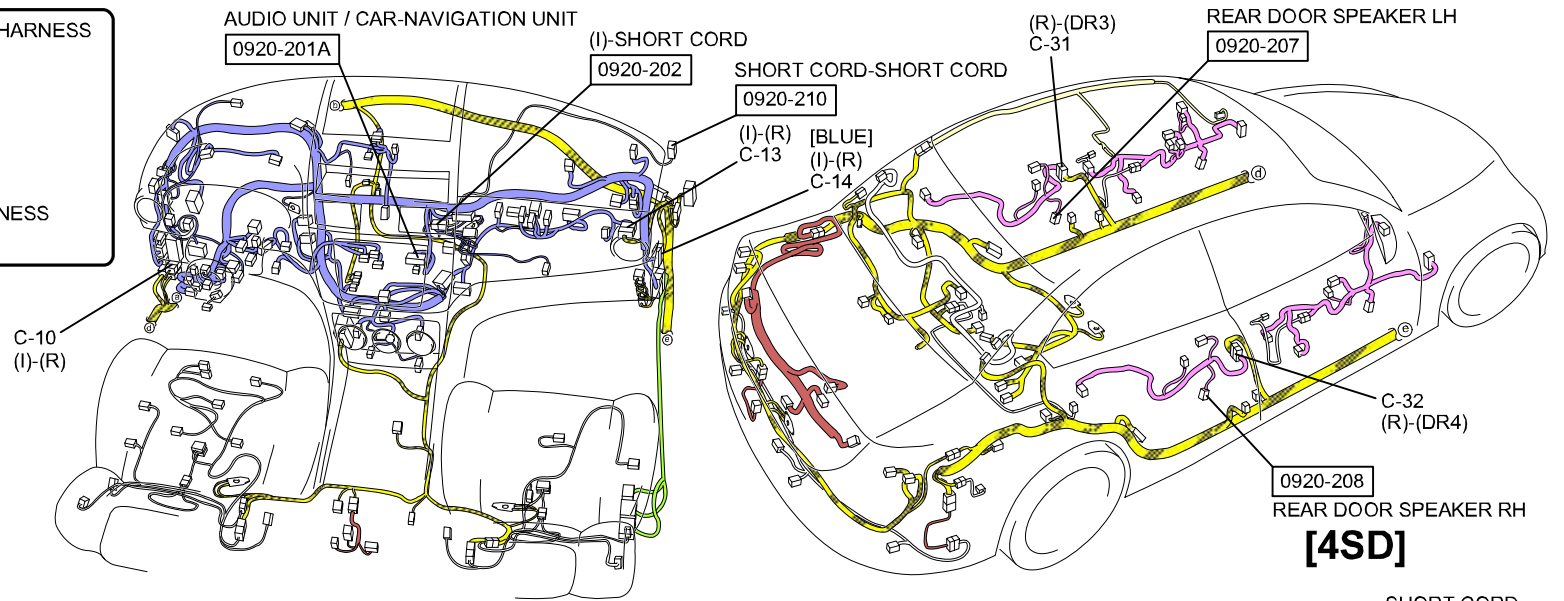

C-10
INSTRUMENT PANEL HARNESS-REAR HARNESS

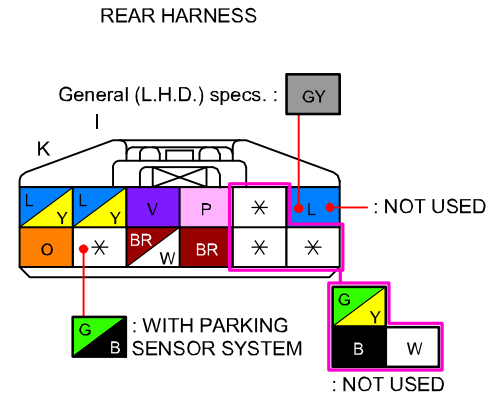
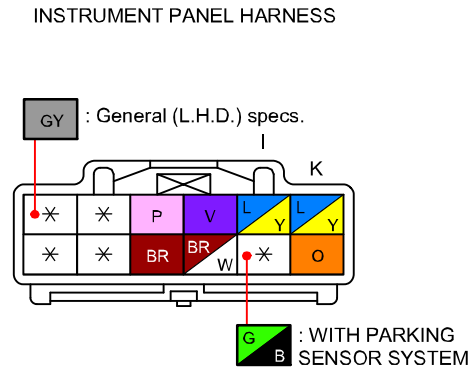

C-13
INSTRUMENT PANEL HARNESS-REAR HARNESS

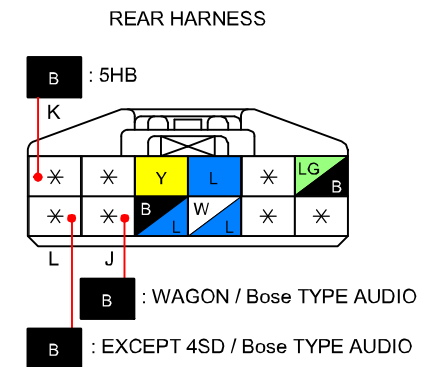
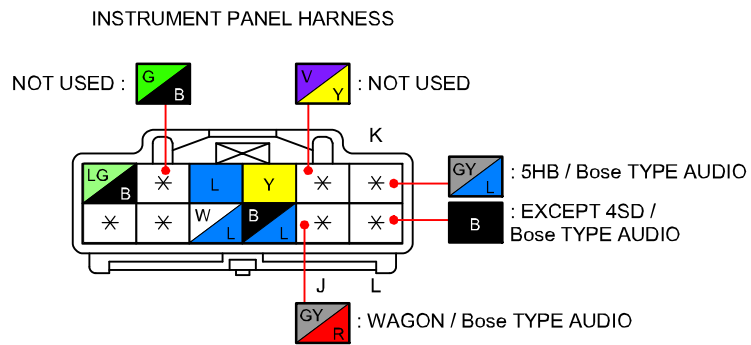

(WITHOUT ADVANCED KEYLESS SYSTEM)

C-14
INSTRUMENT PANEL HARNESS-REAR HARNESS

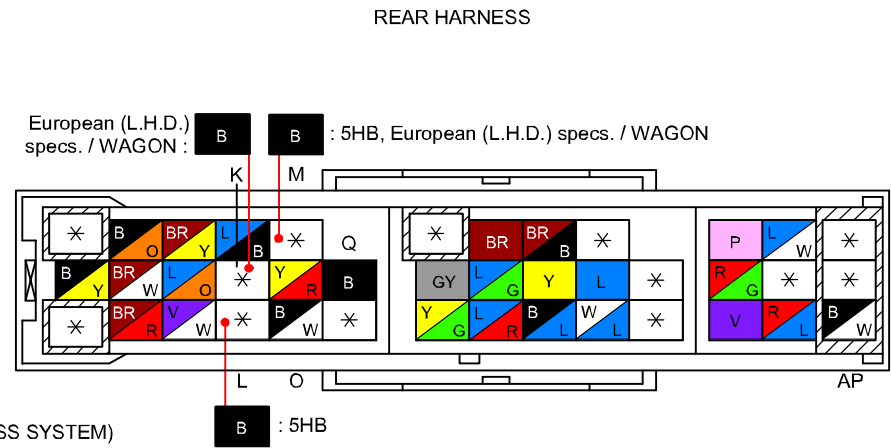
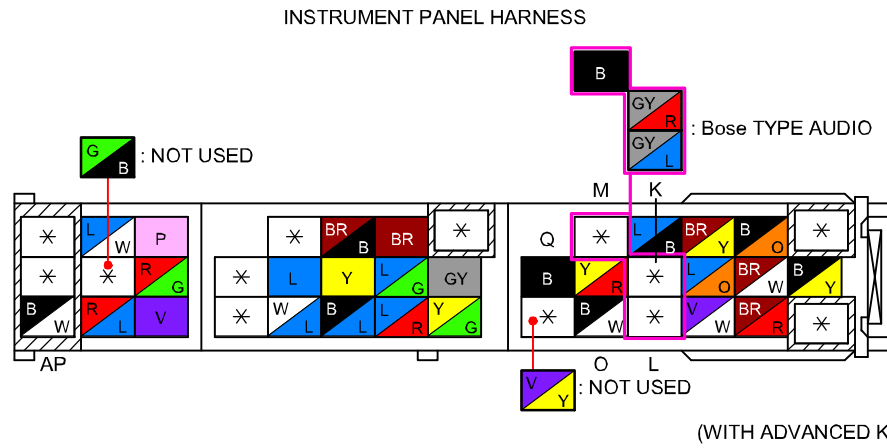

C-31
REAR HARNESS-DOOR NO.3 HARNESS

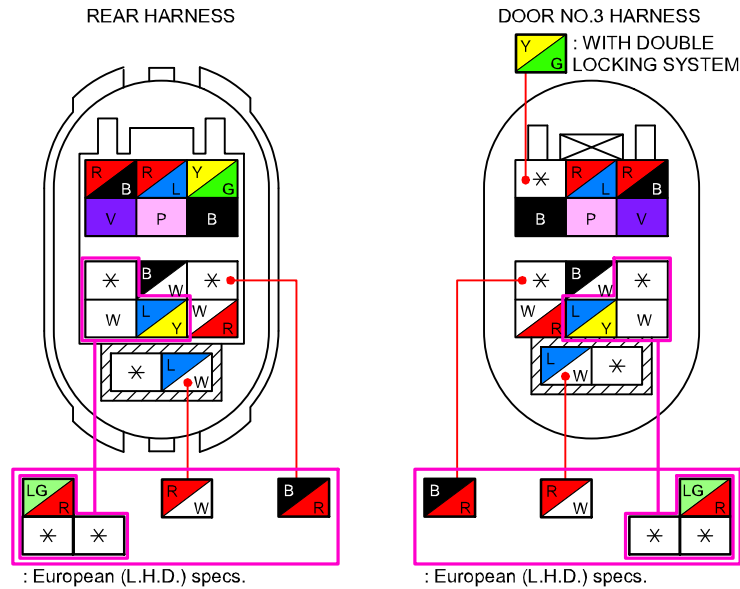

C-32
REAR HARNESS-DOOR NO.4 HARNESS

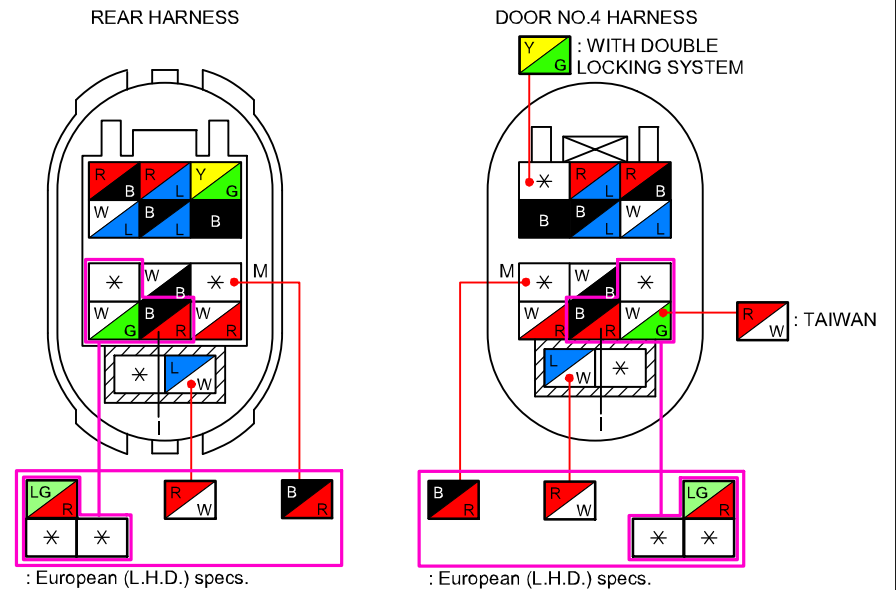

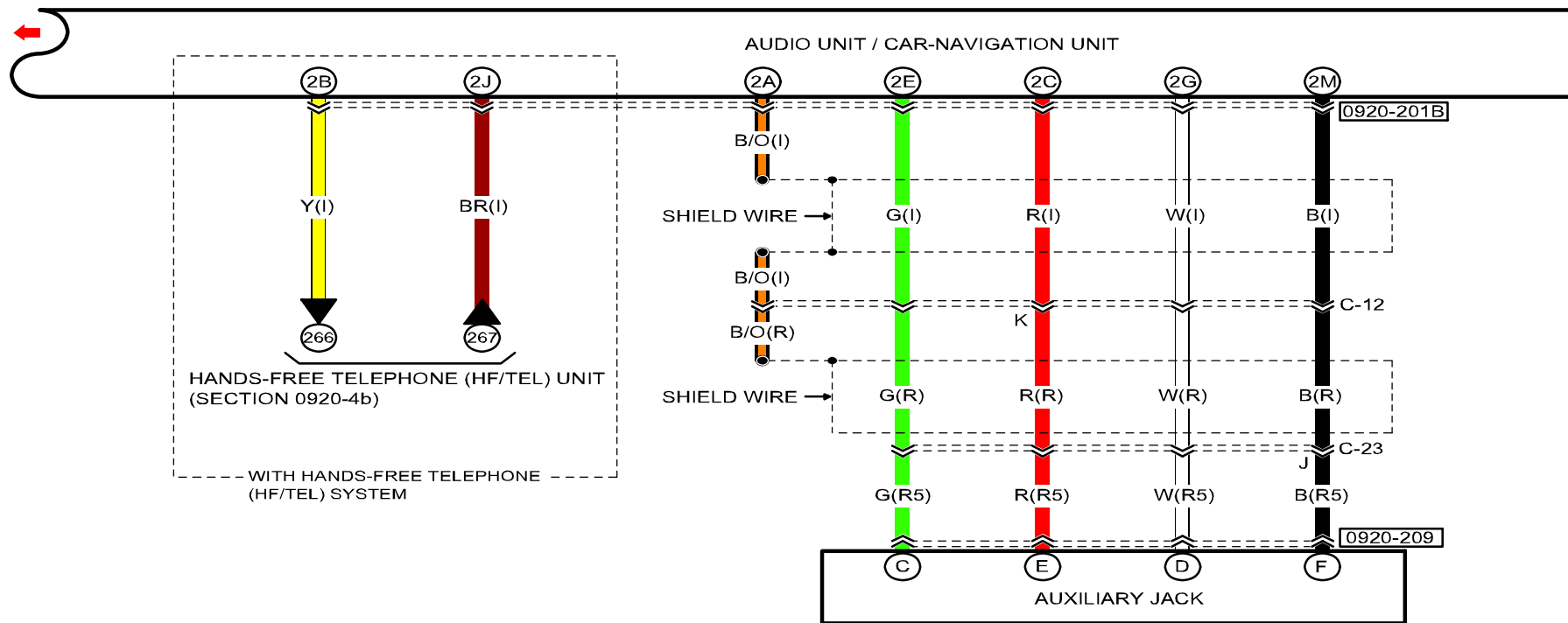



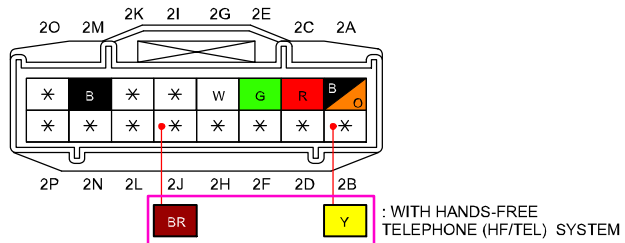

0920-201B
AUDIO UNIT / CAR-NAVIGATION UNIT

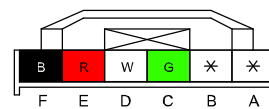

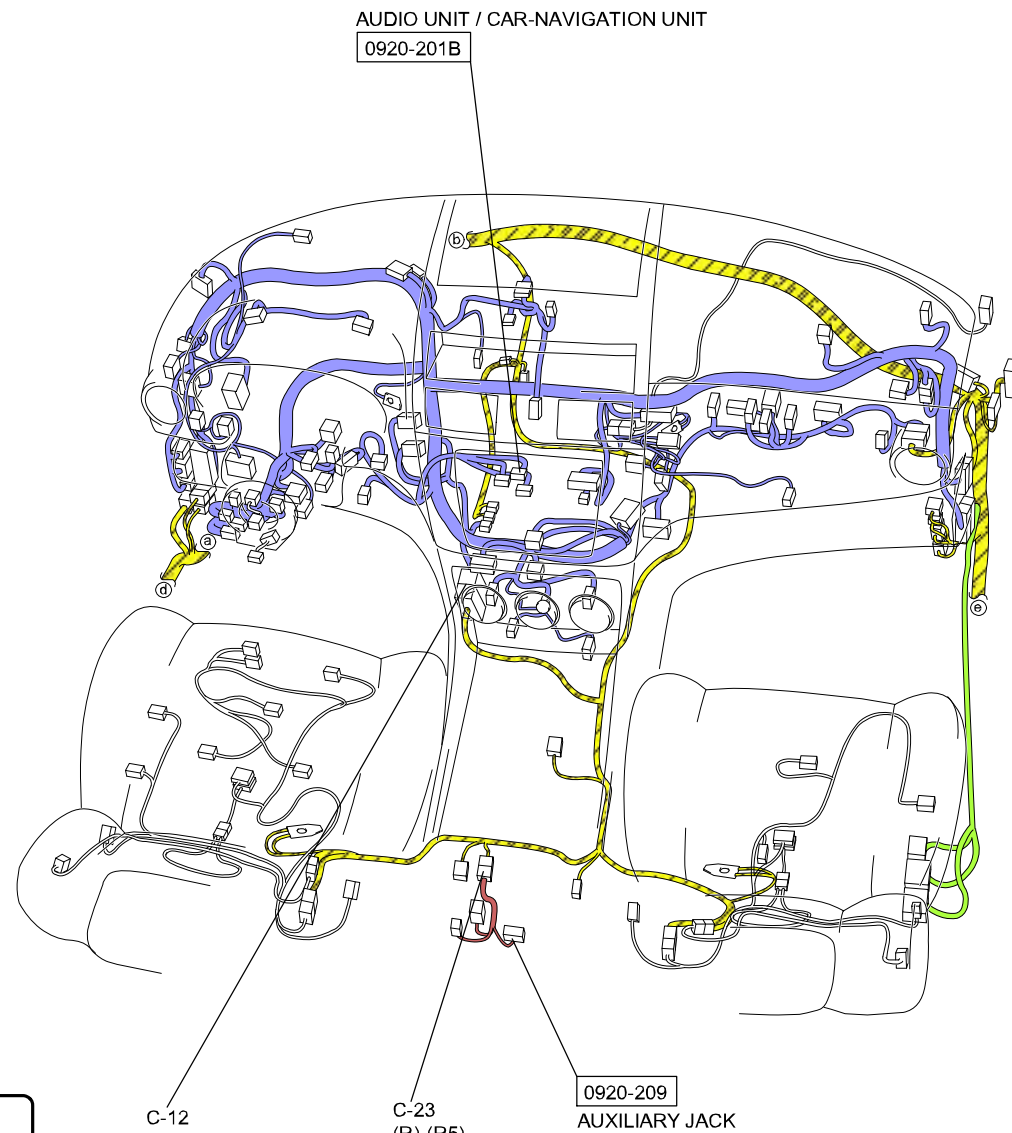
0920-209
AUXILIARY JACK





-  : REAR HARNESS
-  : REAR NO.5 HARNESS
-  : INSTRUMENT PANEL HARNESS
-  : FLOOR HARNESS

C-12
(L)-(R)
[GRAY]

C-23
(R)-(R5)

0920-209
AUXILIARY JACK

C-12
INSTRUMENT PANEL HARNESS-REAR HARNESS

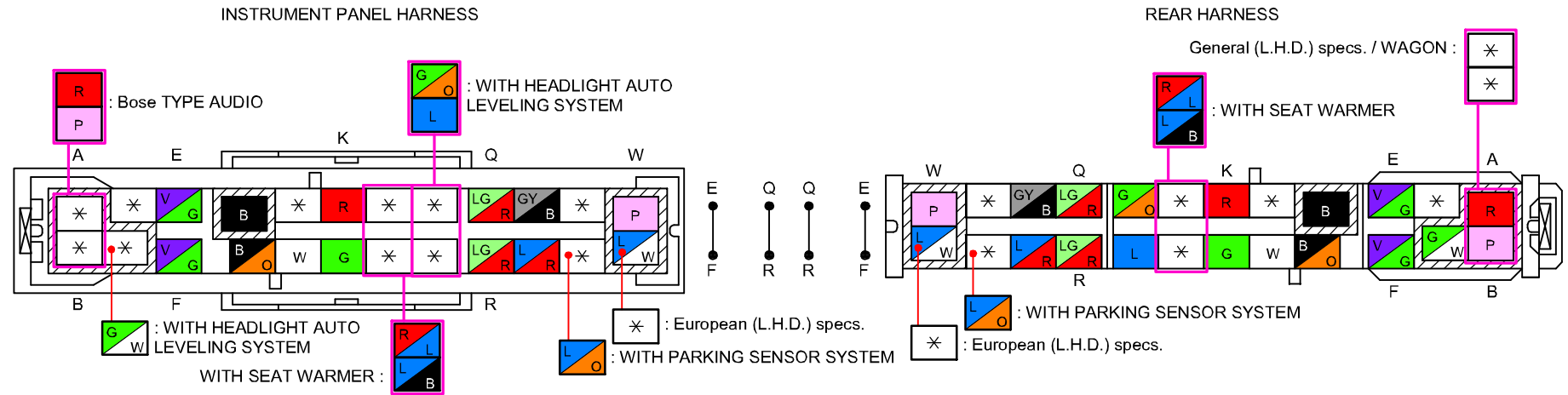

C-23
REAR HARNESS-REAR NO.5 HARNESS

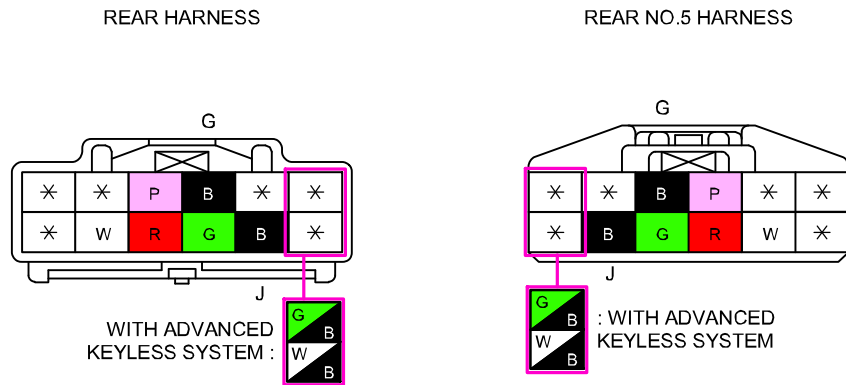

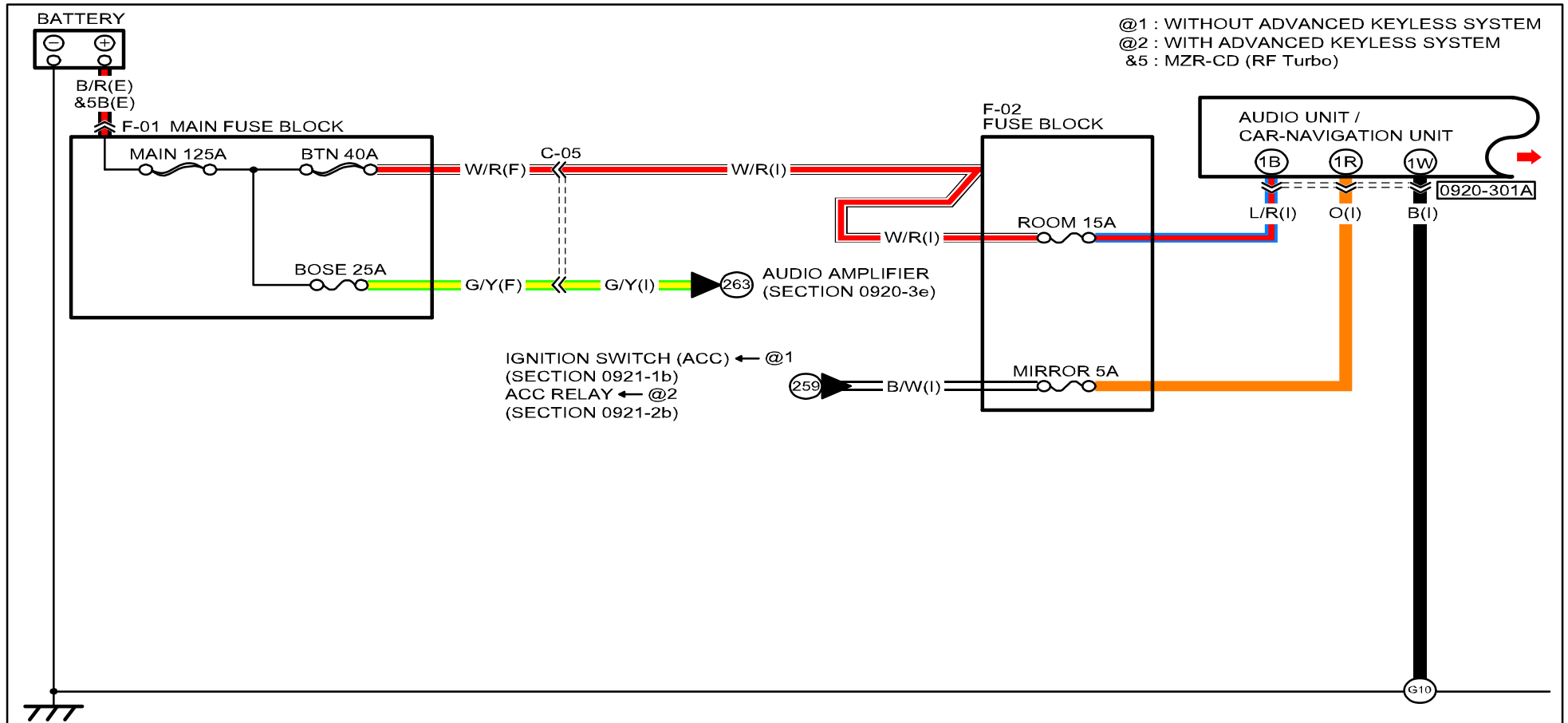

@1 : WITHOUT ADVANCED KEYLESS SYSTEM
 @2 : WITH ADVANCED KEYLESS SYSTEM
 &5 : MZR-CD (RF Turbo)

0920-301A
 AUDIO UNIT / CAR-NAVIGATION UNIT

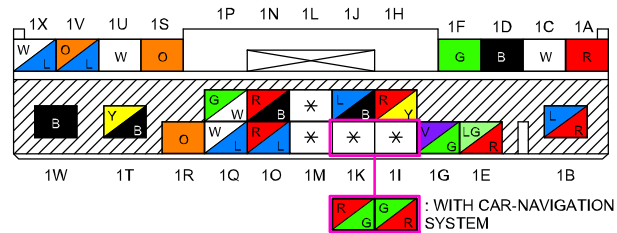

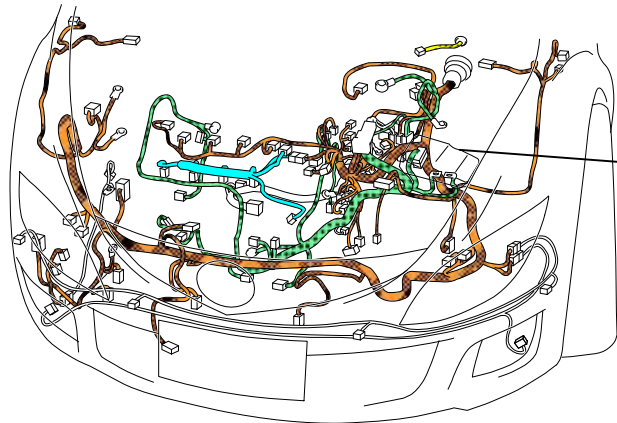

F-01
MAIN FUSE BLOCK
(REFER TO 00F SECTION)

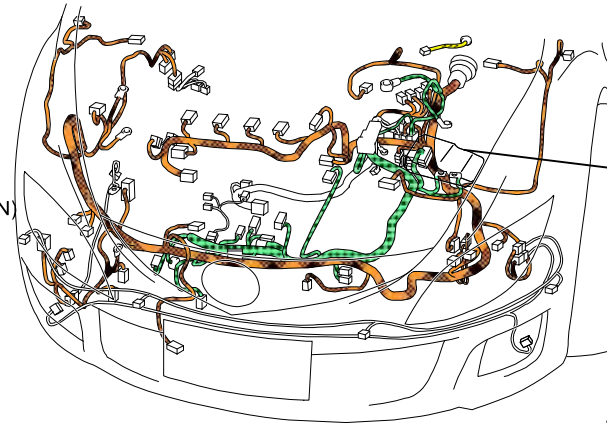

F-01
MAIN FUSE BLOCK
(REFER TO 00F SECTION)

[EXCEPT MZR-CD (RF Turbo)]

[MZR-CD (RF Turbo)]

AUDIO UNIT /
CAR-NAVIGATION UNIT
0920-301A

[BLUE]
(F)-(I)
C-05

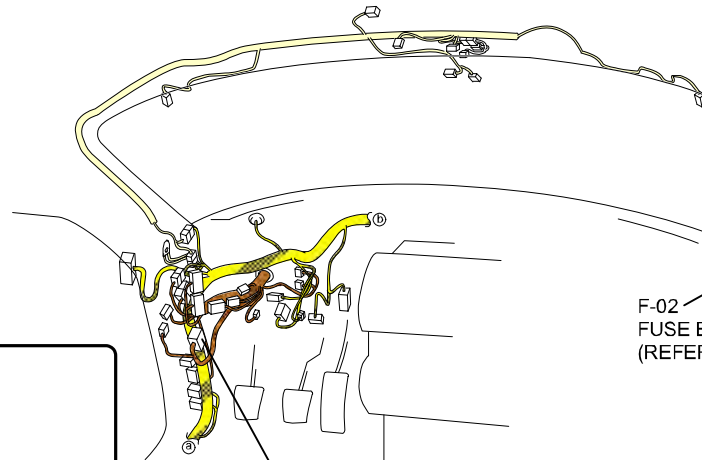

C-05
(F)-(I)
[BLUE]

F-02
FUSE BLOCK
(REFER TO 00F SECTION)

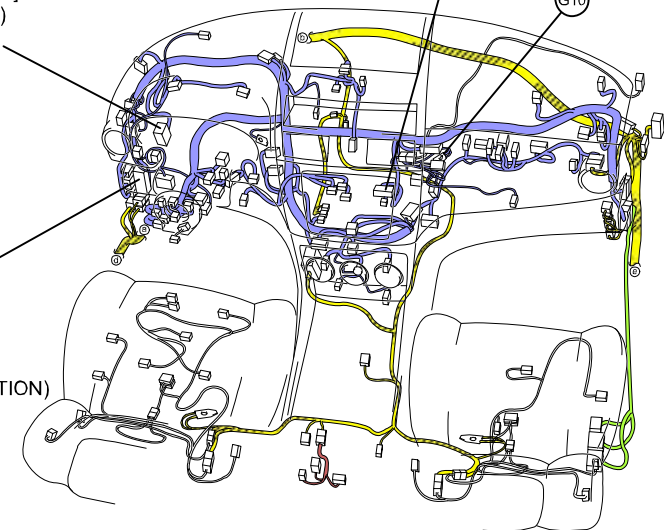

- : FRONT HARNESS
- : ENGINE HARNESS
- : INJECTION HARNESS
- : REAR HARNESS
- : REAR NO.5 HARNESS
- : INSTRUMENT PANEL HARNESS
- : FLOOR HARNESS
- : INTERIOR LIGHT NO.2 HARNESS

C-05

FRONT HARNESS-INSTRUMENT PANEL HARNESS

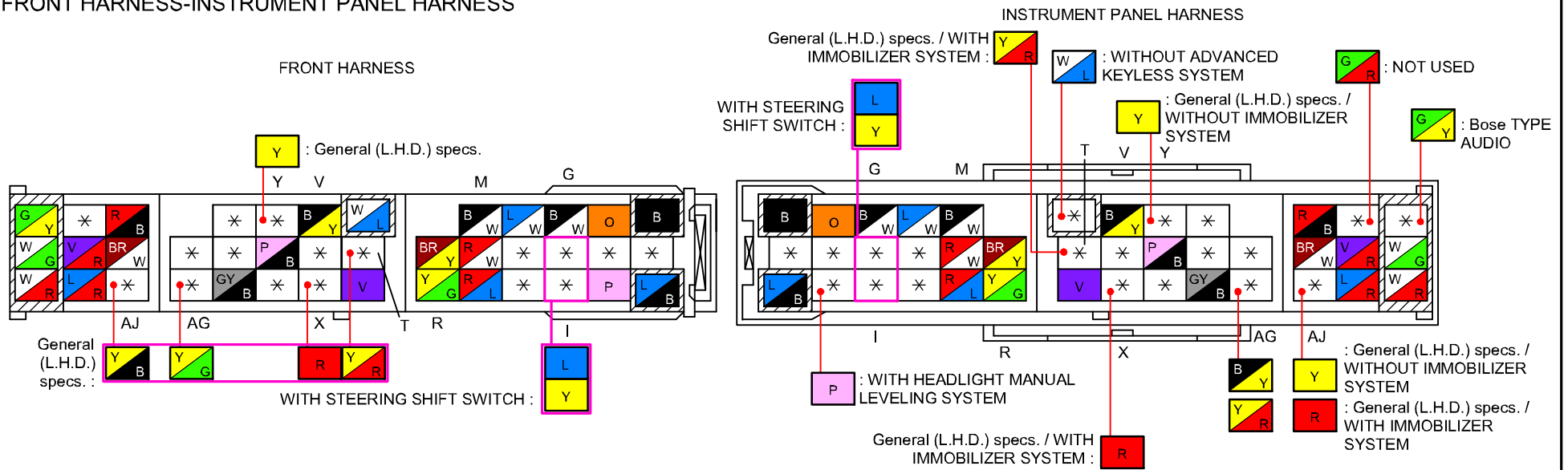

: WITH HANDS-FREE TELEPHONE (HF/TEL) SYSTEM,
WITH CAR-NAVIGATION SYSTEM
&3 : VOICE RECOGNITION/HANDS FREE, MUTE

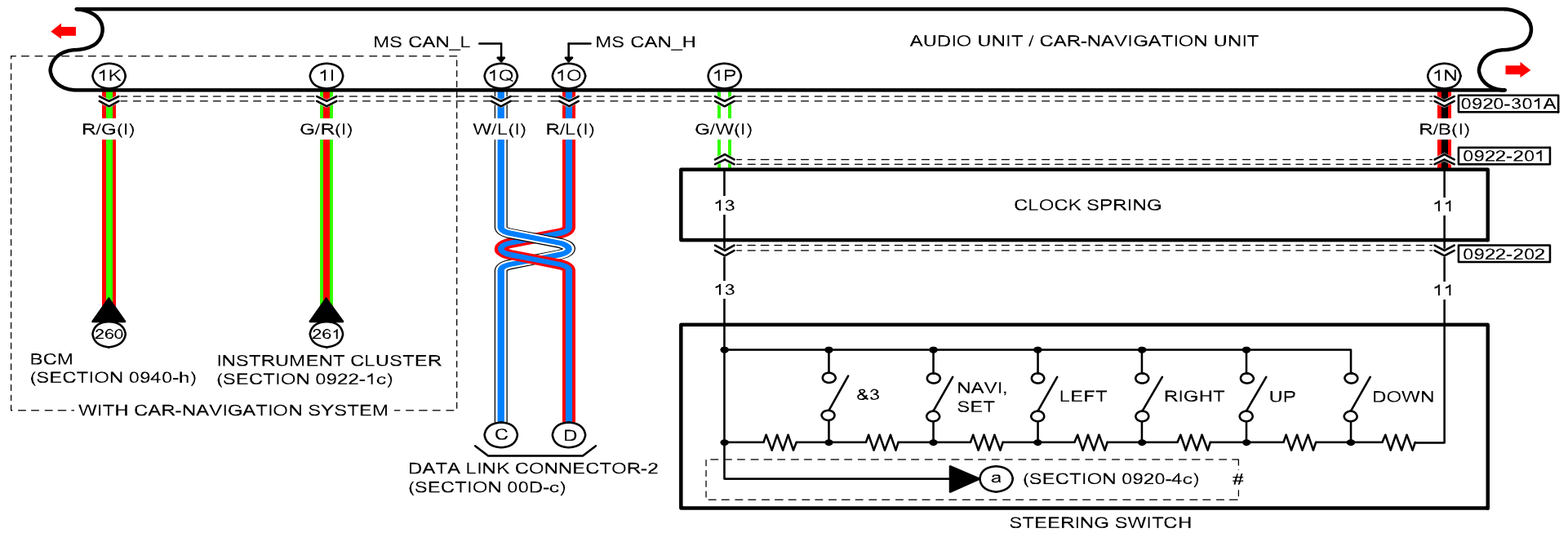

0920-301A
AUDIO UNIT / CAR-NAVIGATION UNIT

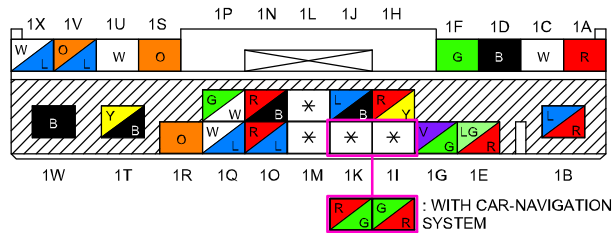

0922-201
CLOCK SPRING

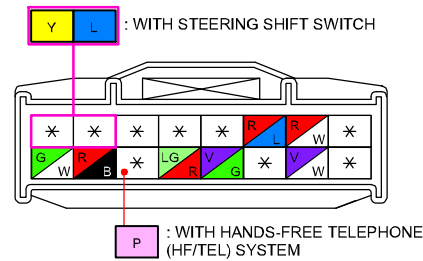

0922-202
CRUISE CONTROL SWITCH /
UP SWITCH / DOWN SWITCH /
STEERING SWITCH ILLUMINATION /
UP SWITCH ILLUMINATION /
DOWN SWITCH ILLUMINATION /
CRUISE CONTROL SWITCH ILLUMINATION /
STEERING SWITCH /
CLOCK SPRING

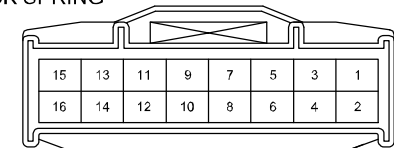

TERMINALS OF THIS CONNECTOR
ARE INDICATED BY NUMBERS.

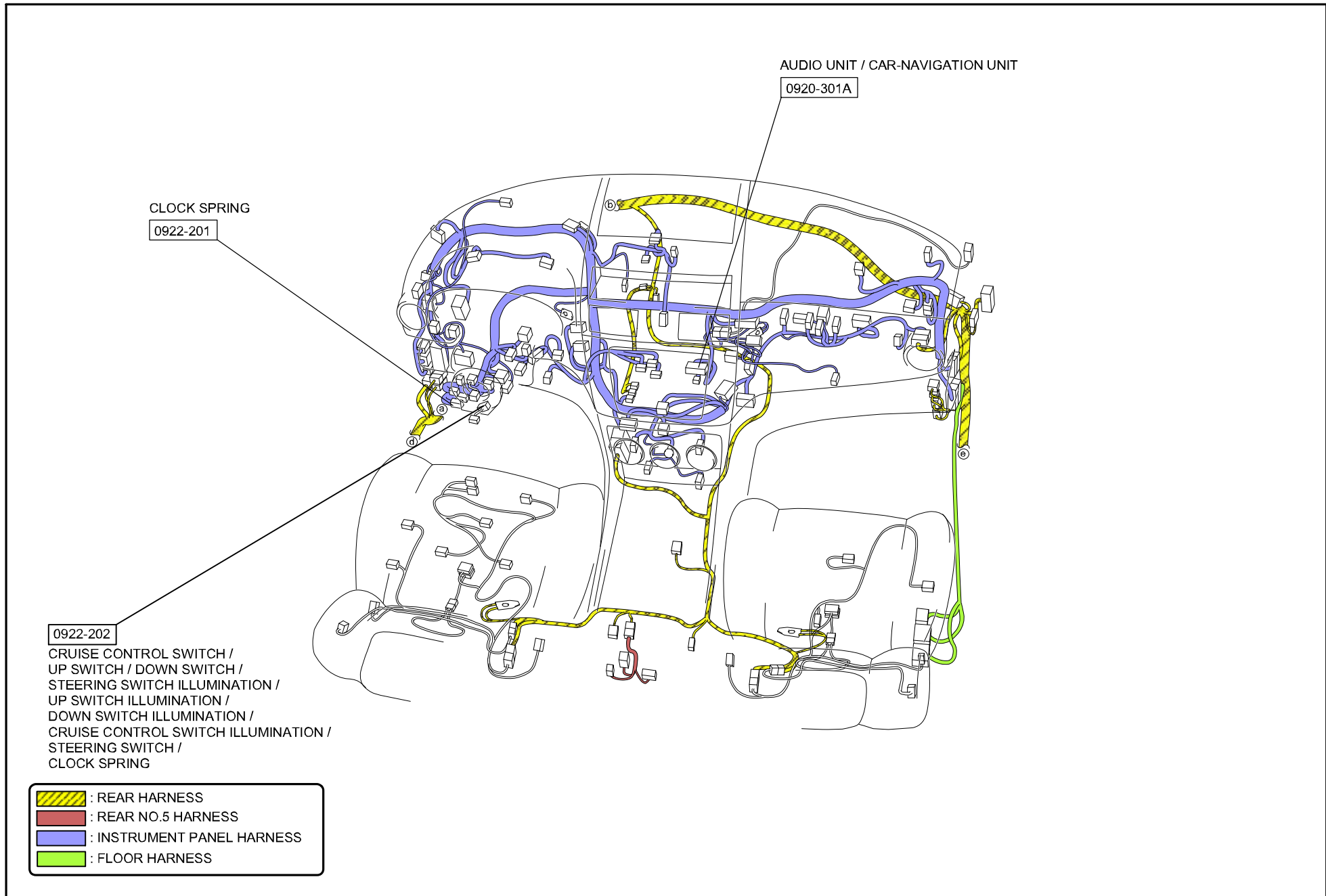

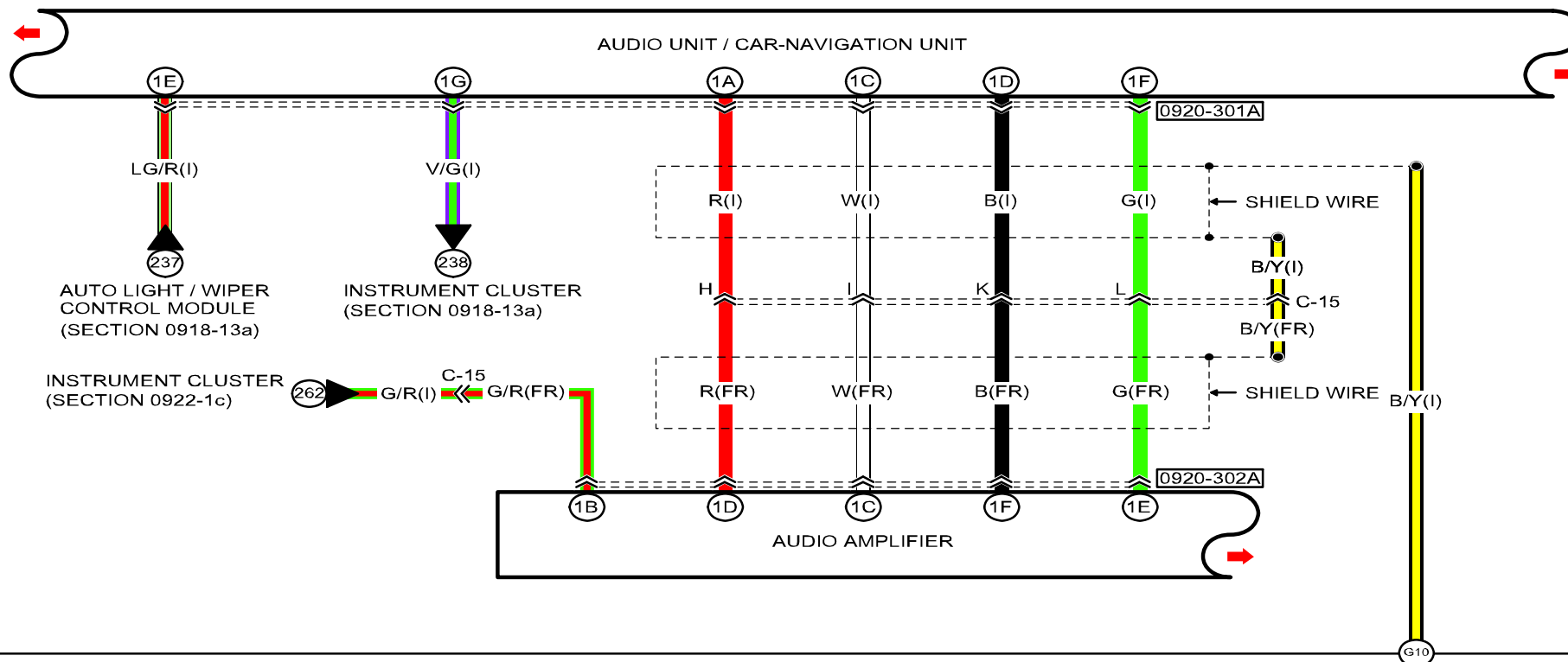



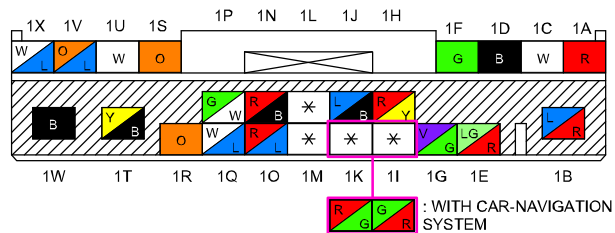

0920-301A
AUDIO UNIT / CAR-NAVIGATION UNIT

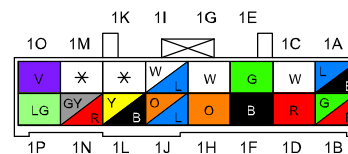

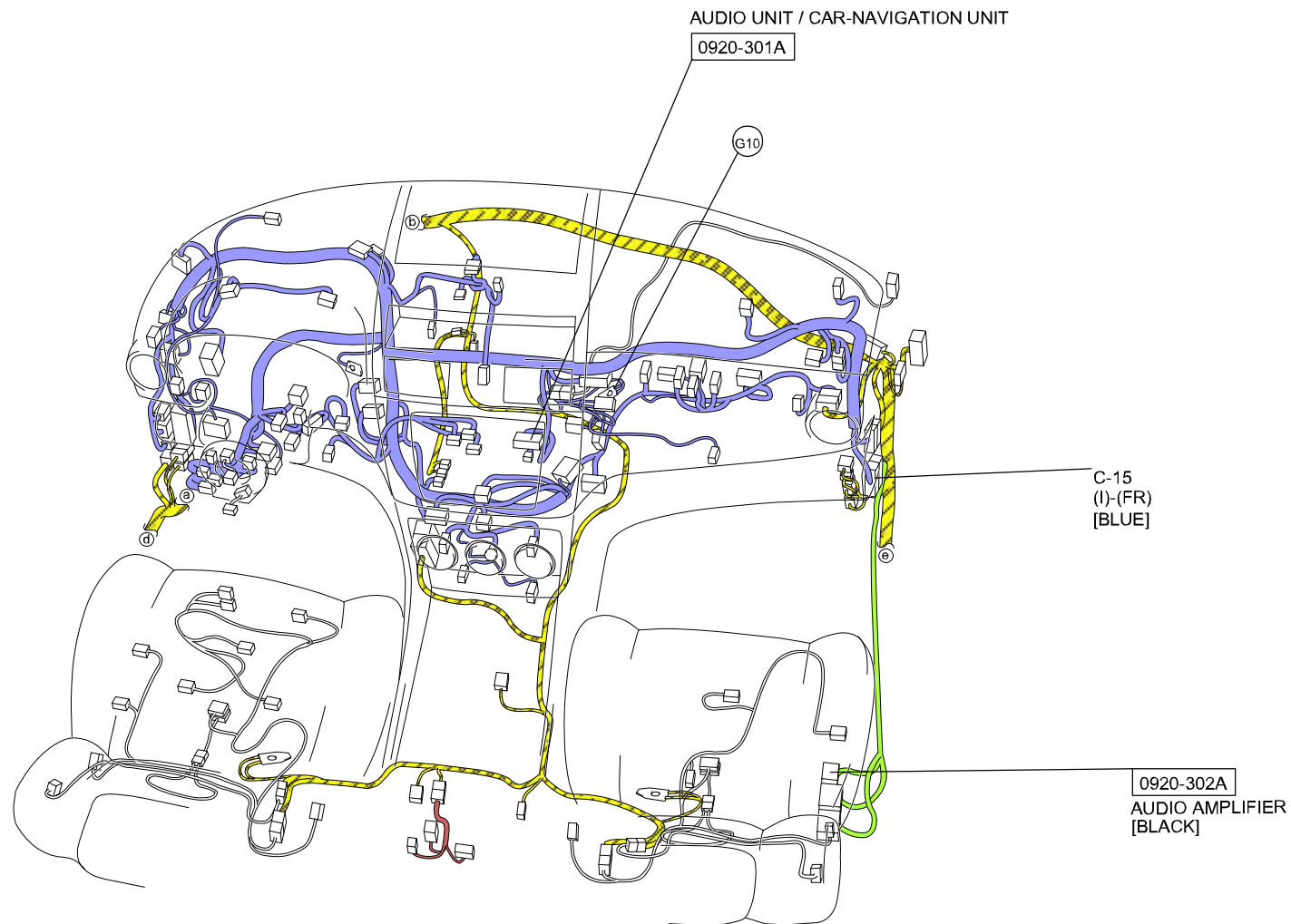
0920-302A
AUDIO AMPLIFIER





-  : REAR HARNESS
-  : REAR NO.5 HARNESS
-  : INSTRUMENT PANEL HARNESS
-  : FLOOR HARNESS

C-15
INSTRUMENT PANEL HARNESS-FLOOR HARNESS

INSTRUMENT PANEL HARNESS

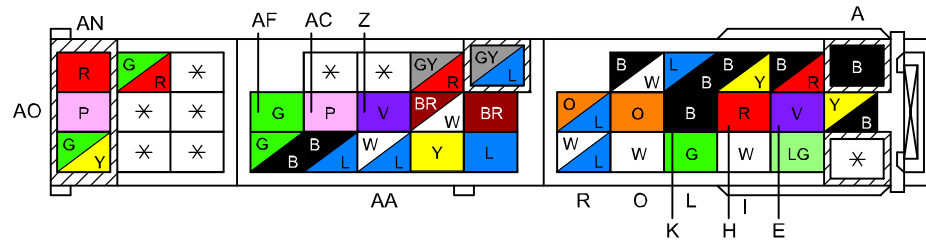



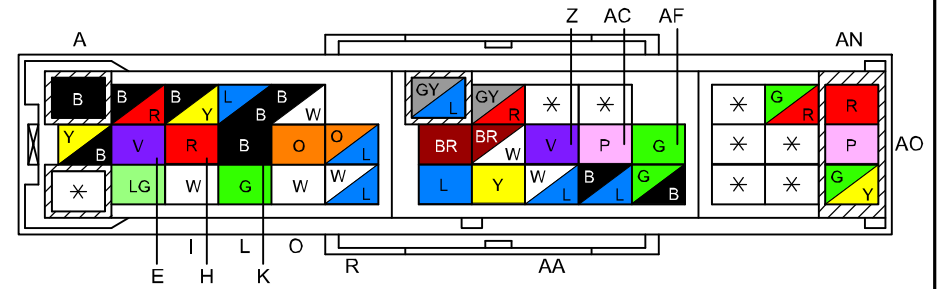



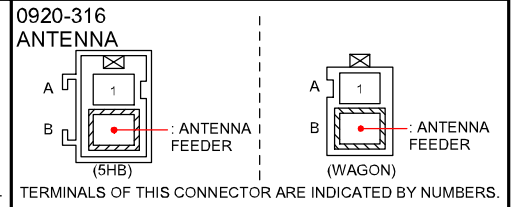
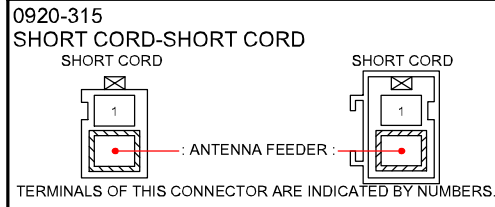
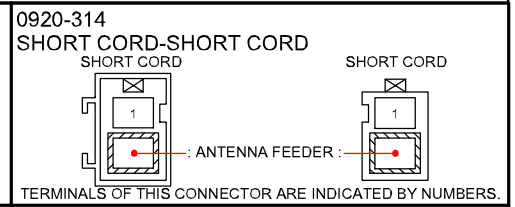
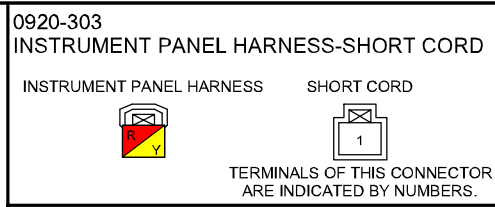
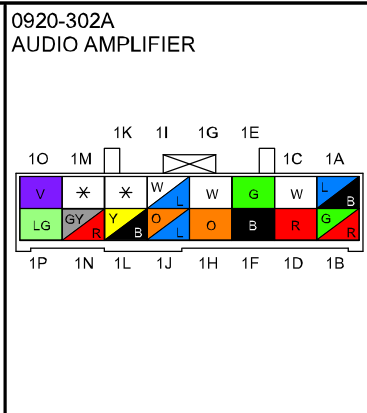
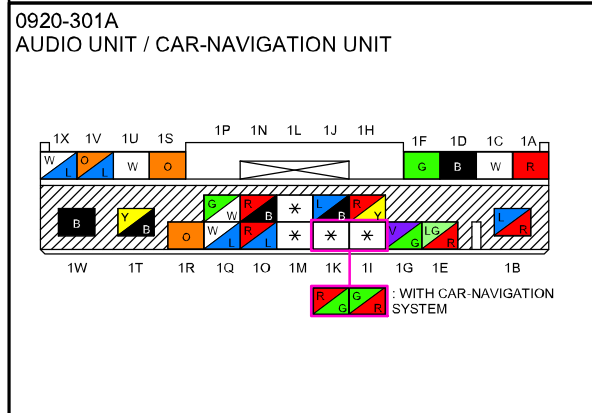
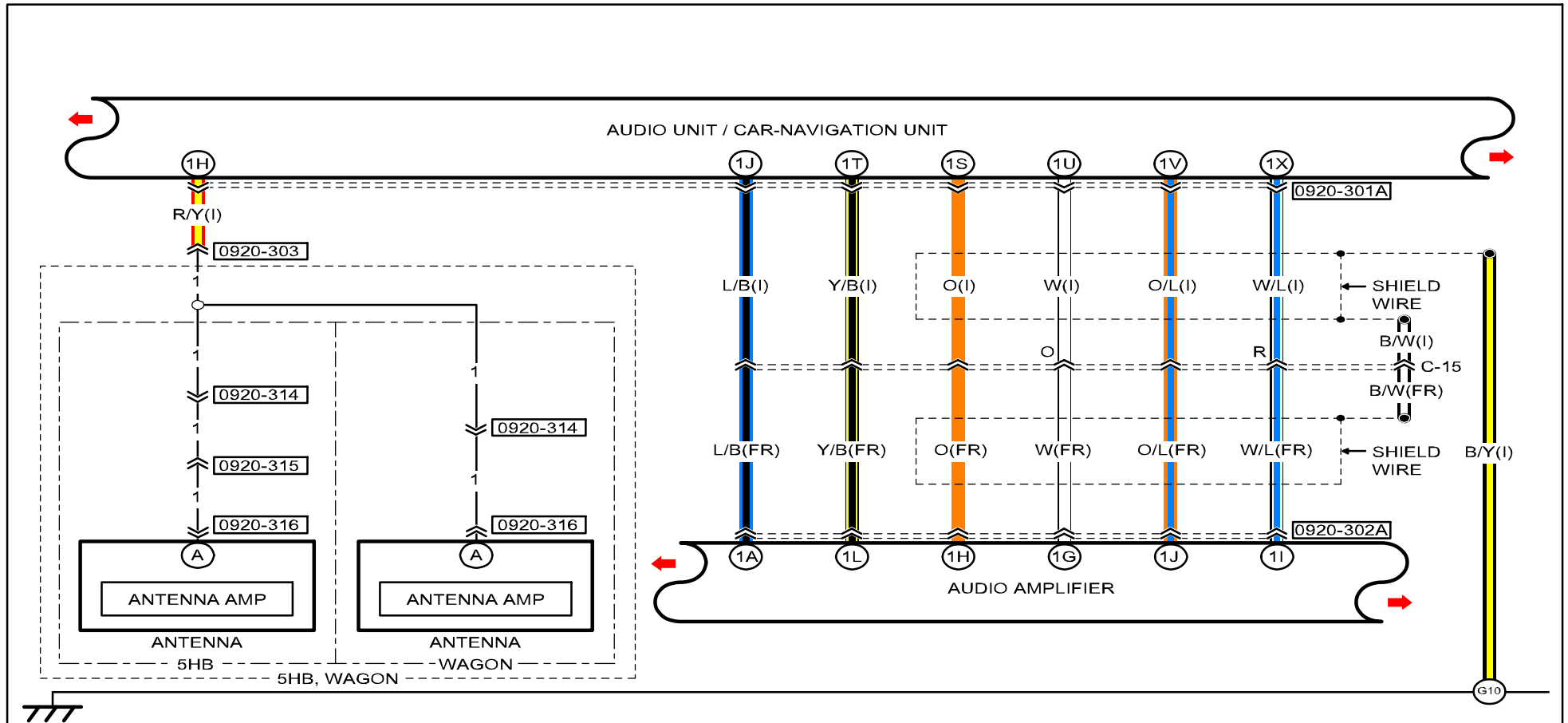

FLOOR HARNESS



(Bose TYPE AUDIO)



-  : REAR HARNESS
-  : REAR NO.2 HARNESS
-  : REAR NO.3 HARNESS
-  : REAR NO.4 HARNESS
-  : REAR NO.5 HARNESS
-  : DOOR HARNESS
-  : INTERIOR LIGHT HARNESS
-  : FLOOR HARNESS
-  : INSTRUMENT PANEL HARNESS

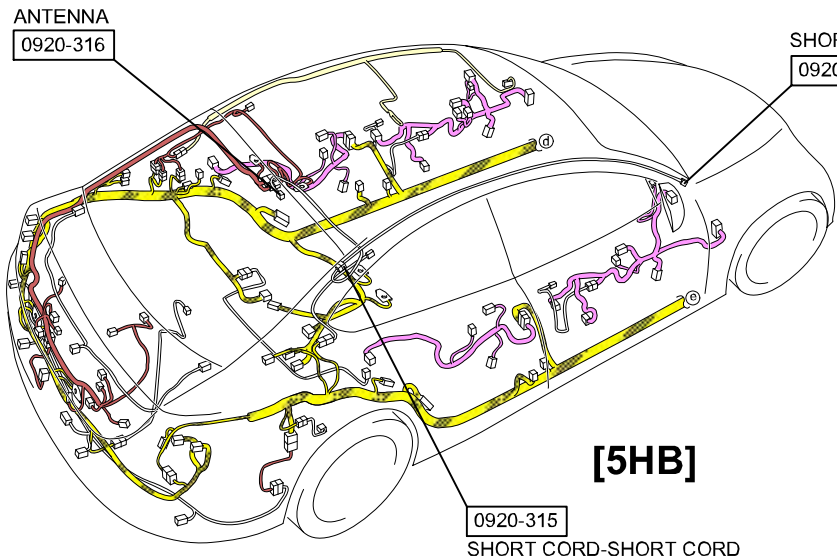
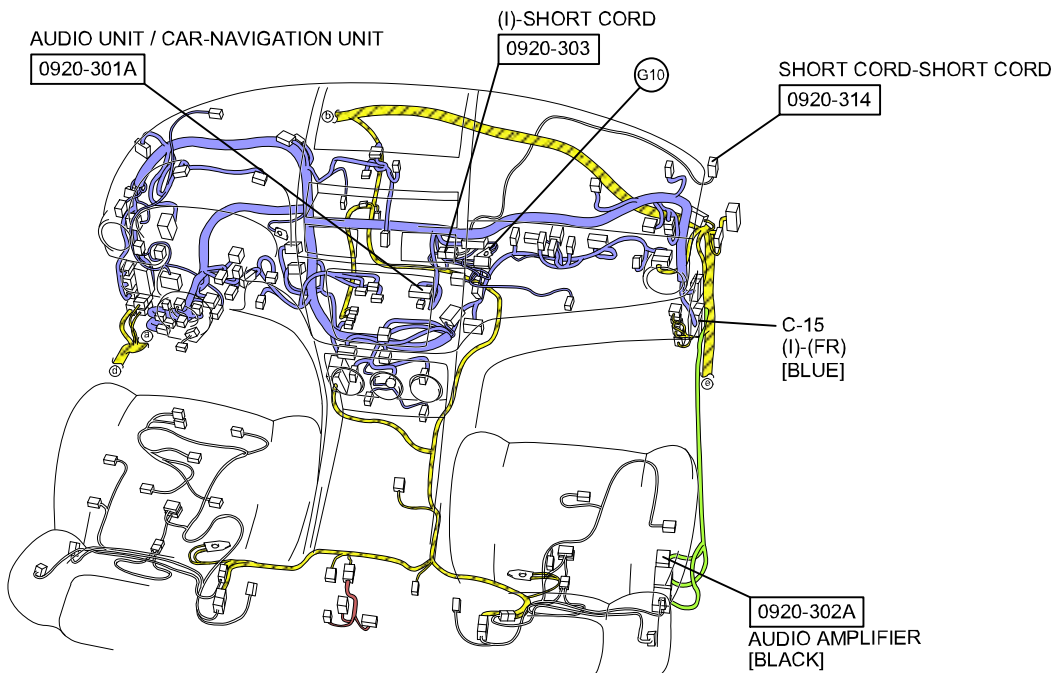

[5HB]

0920-315
SHORT CORD-SHORT CORD

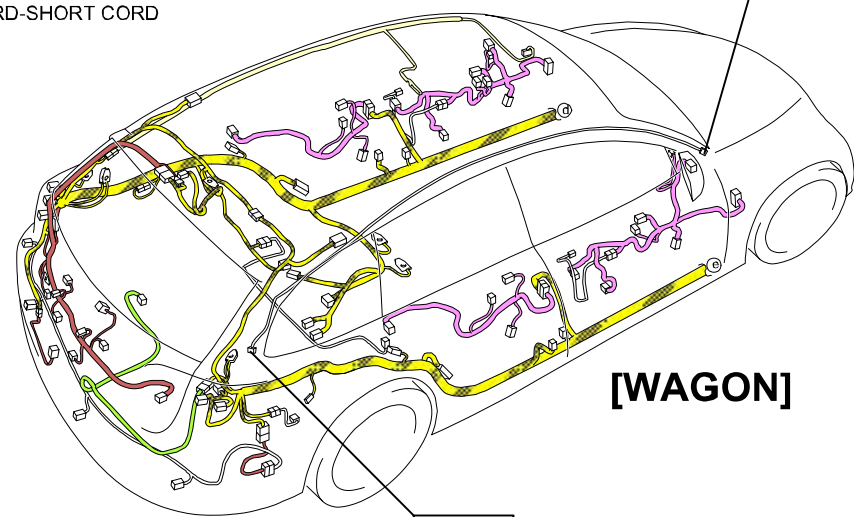

[WAGON]

C-15

INSTRUMENT PANEL HARNESS-FLOOR HARNESS

INSTRUMENT PANEL HARNESS

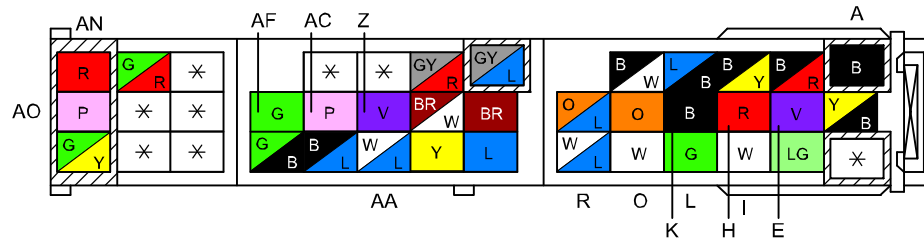

FLOOR HARNESS

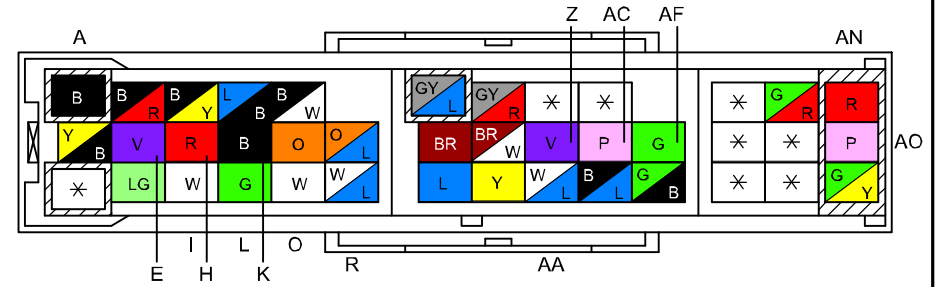

(Bose TYPE AUDIO)

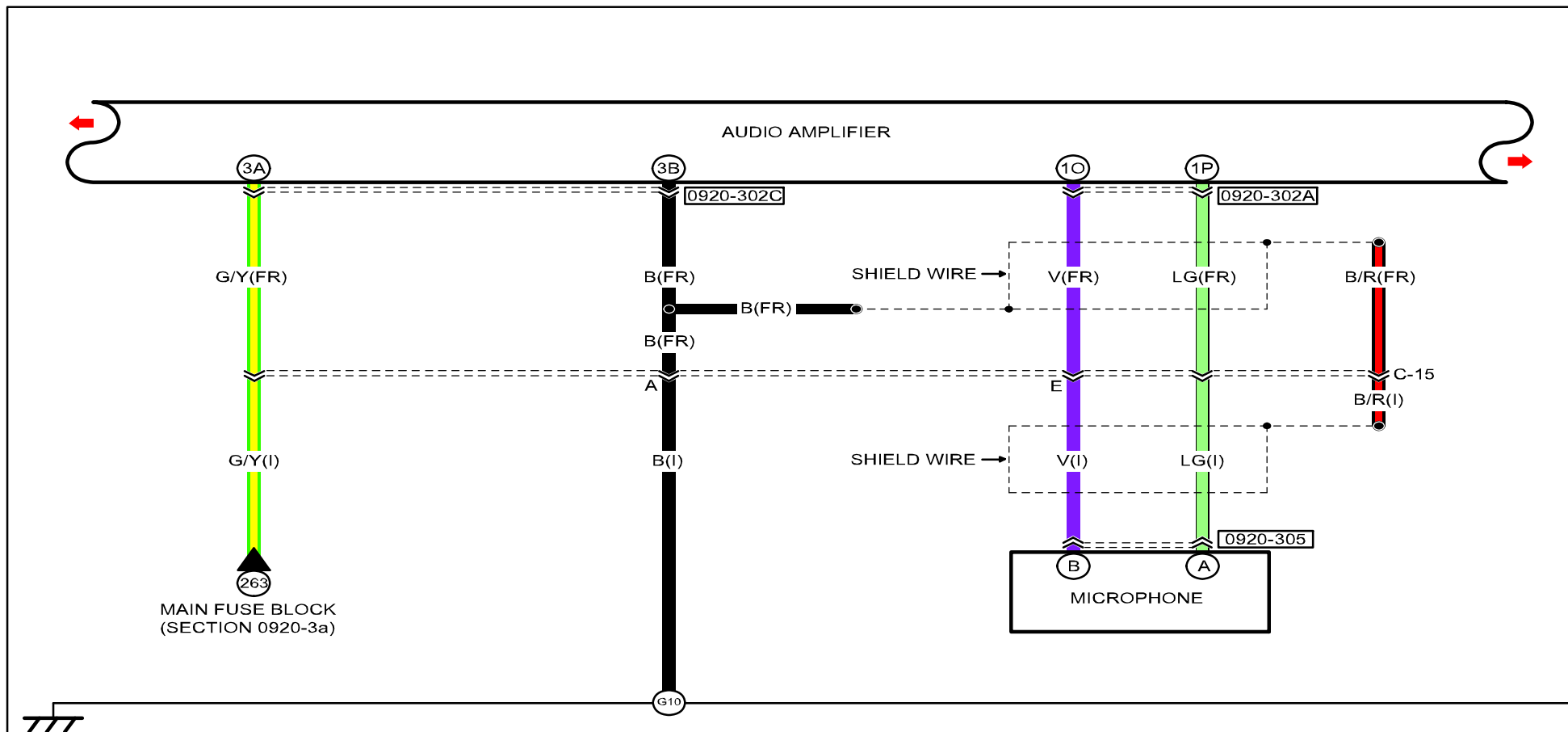

<p>0920-302A AUDIO AMPLIFIER</p>	<p>0920-302C AUDIO AMPLIFIER</p>	<p>0920-305 MICROPHONE</p>		

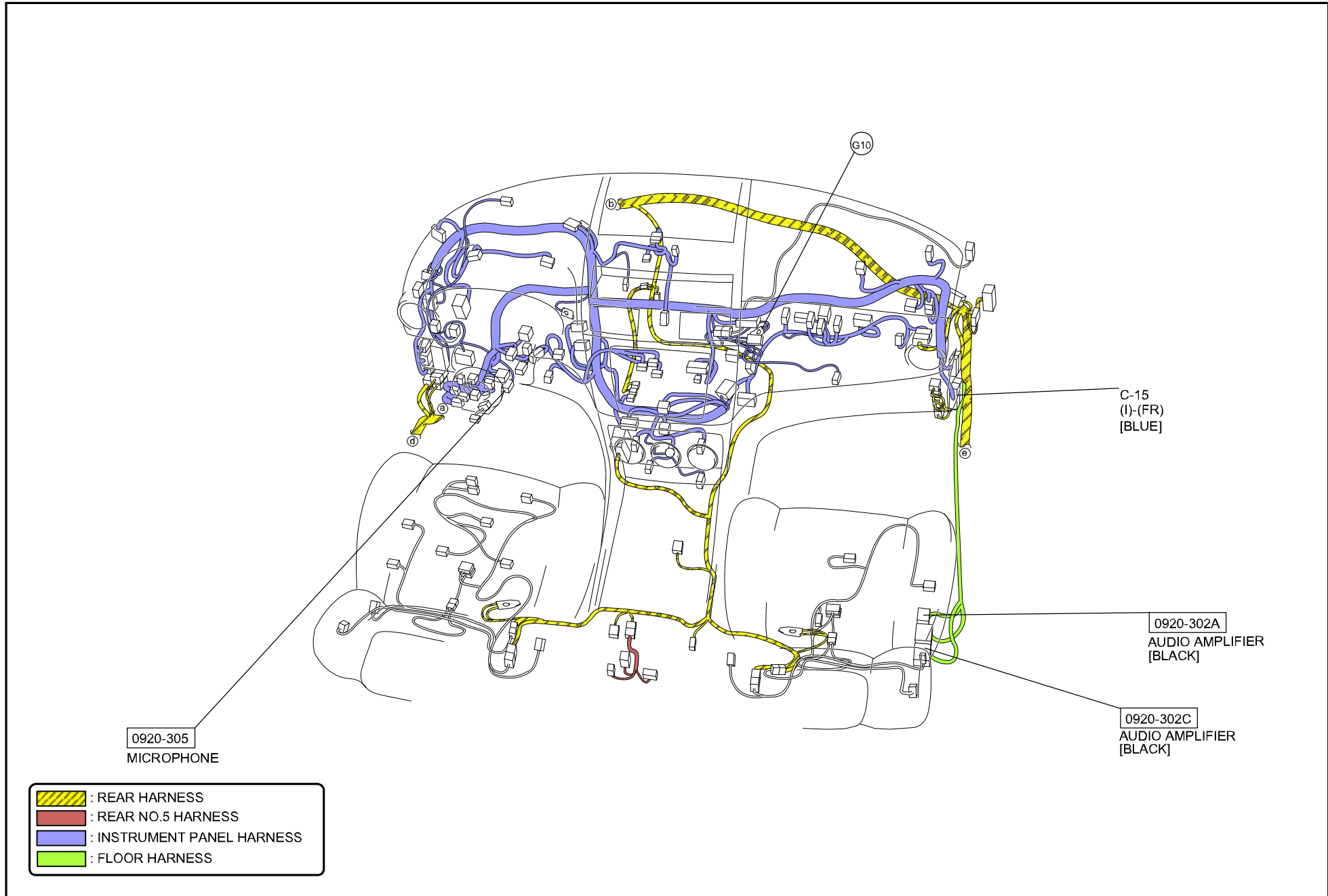

C-15

INSTRUMENT PANEL HARNESS-FLOOR HARNESS

INSTRUMENT PANEL HARNESS

FLOOR HARNESS

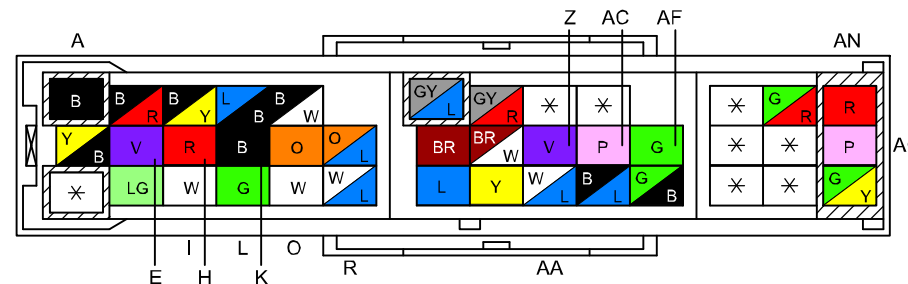
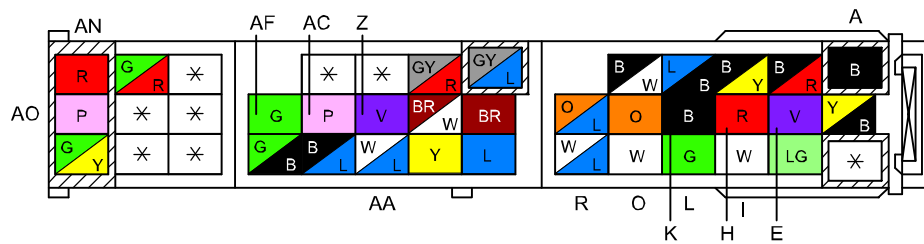

(Bose TYPE AUDIO)

@1 : WITHOUT ADVANCED KEYLESS SYSTEM
 @2 : WITH ADVANCED KEYLESS SYSTEM

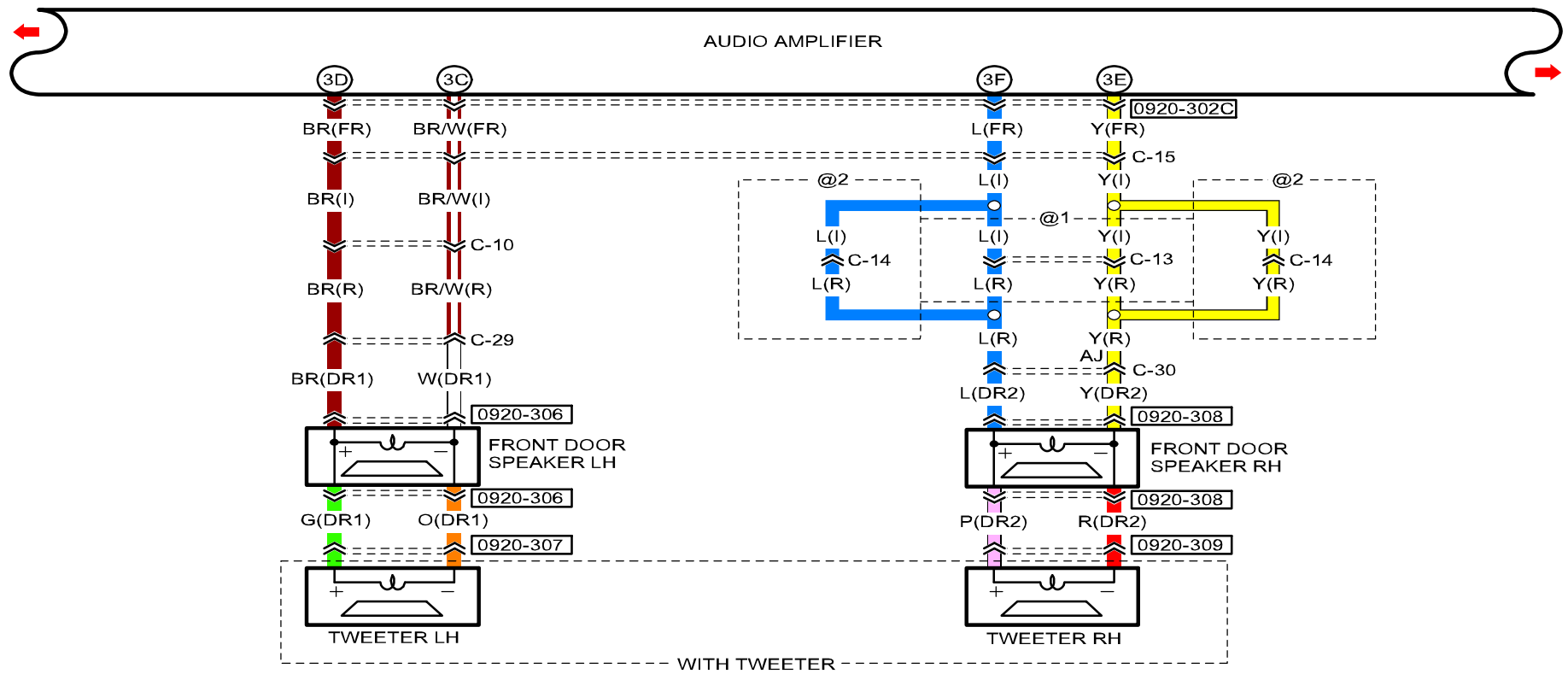

<p>0920-302C AUDIO AMPLIFIER</p>	<p>0920-306 FRONT DOOR SPEAKER LH</p>	<p>0920-307 TWEETER LH</p>	<p>0920-308 FRONT DOOR SPEAKER RH</p>	<p>0920-309 TWEETER RH</p>

AUDIO SYSTEM (Bose® TYPE AUDIO)

0920-3f

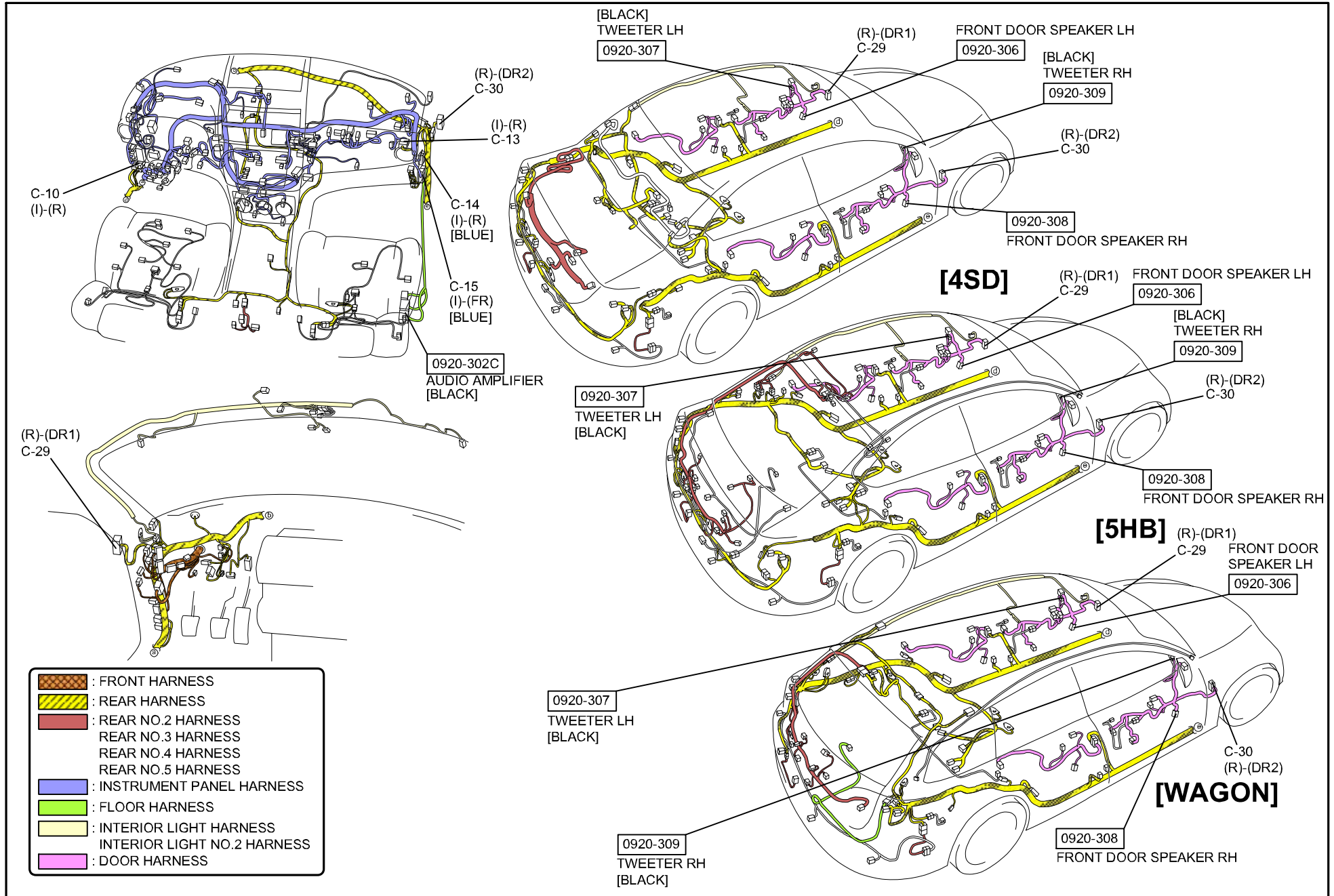

C-10
INSTRUMENT PANEL HARNESS-REAR HARNESS

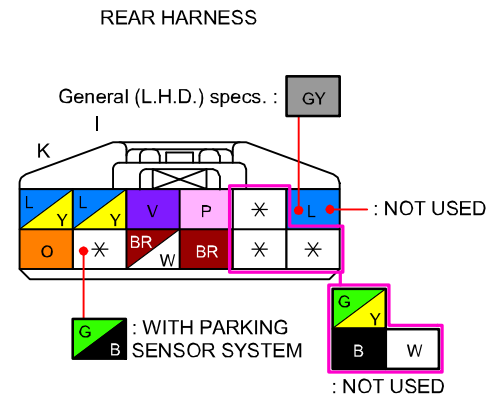
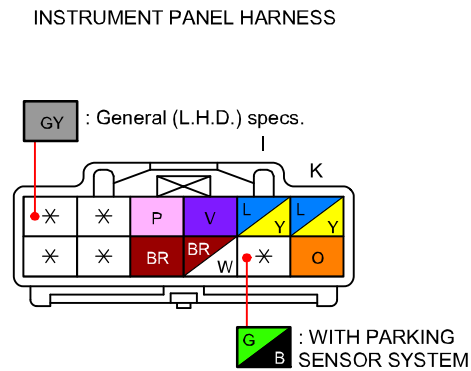

C-13
INSTRUMENT PANEL HARNESS-REAR HARNESS

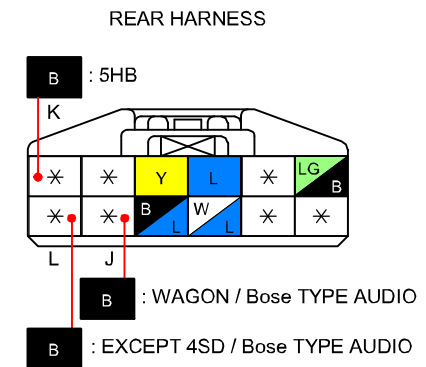
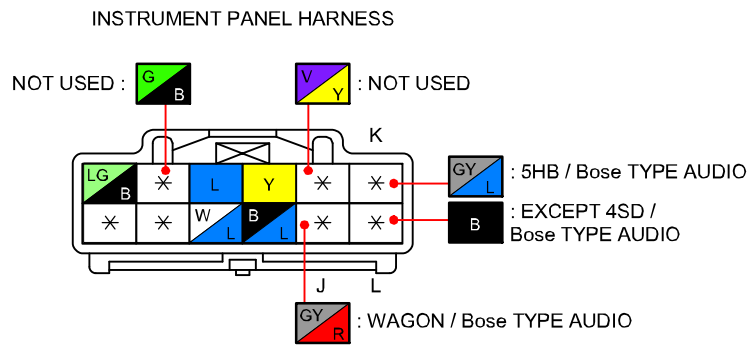

(WITHOUT ADVANCED KEYLESS SYSTEM)

C-14
INSTRUMENT PANEL HARNESS-REAR HARNESS

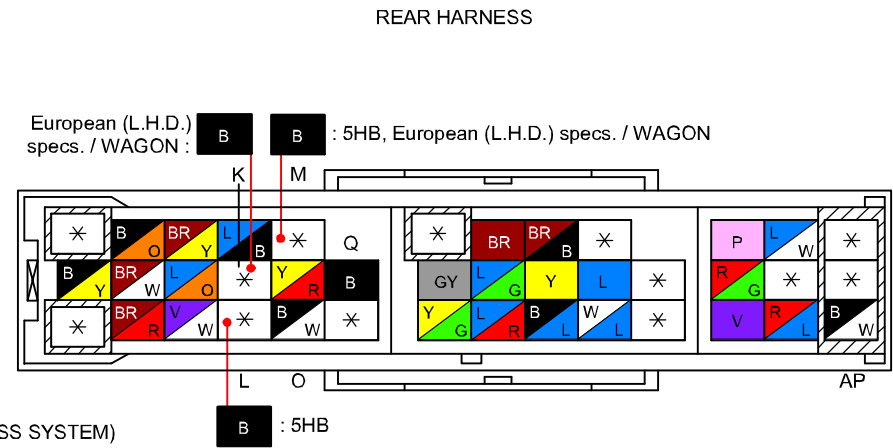
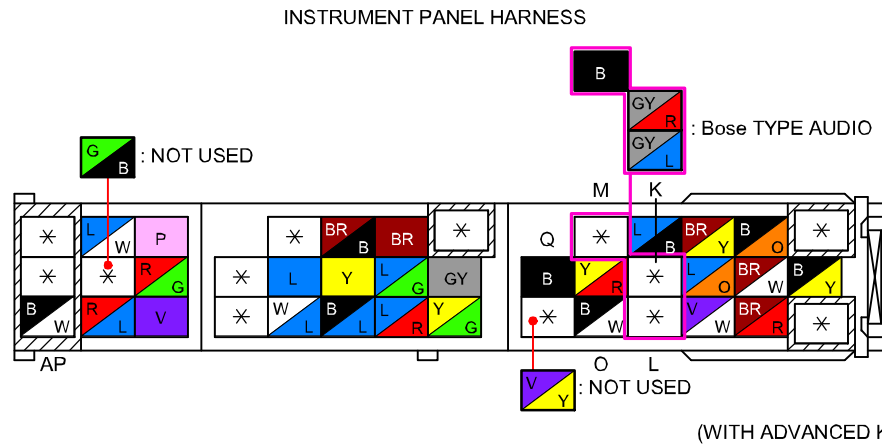

C-15
INSTRUMENT PANEL HARNESS-FLOOR HARNESS

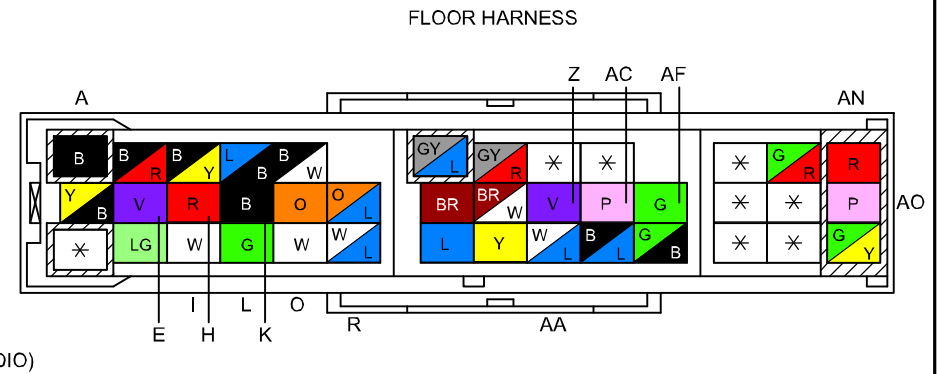
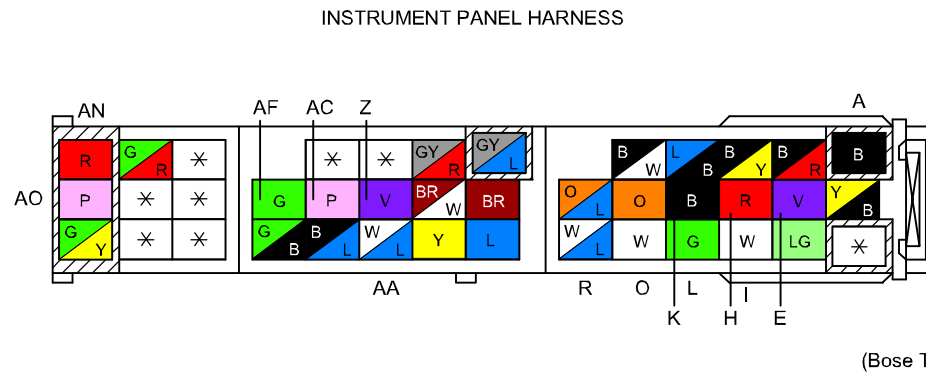

C-29

REAR HARNESS-DOOR NO.1 HARNESS

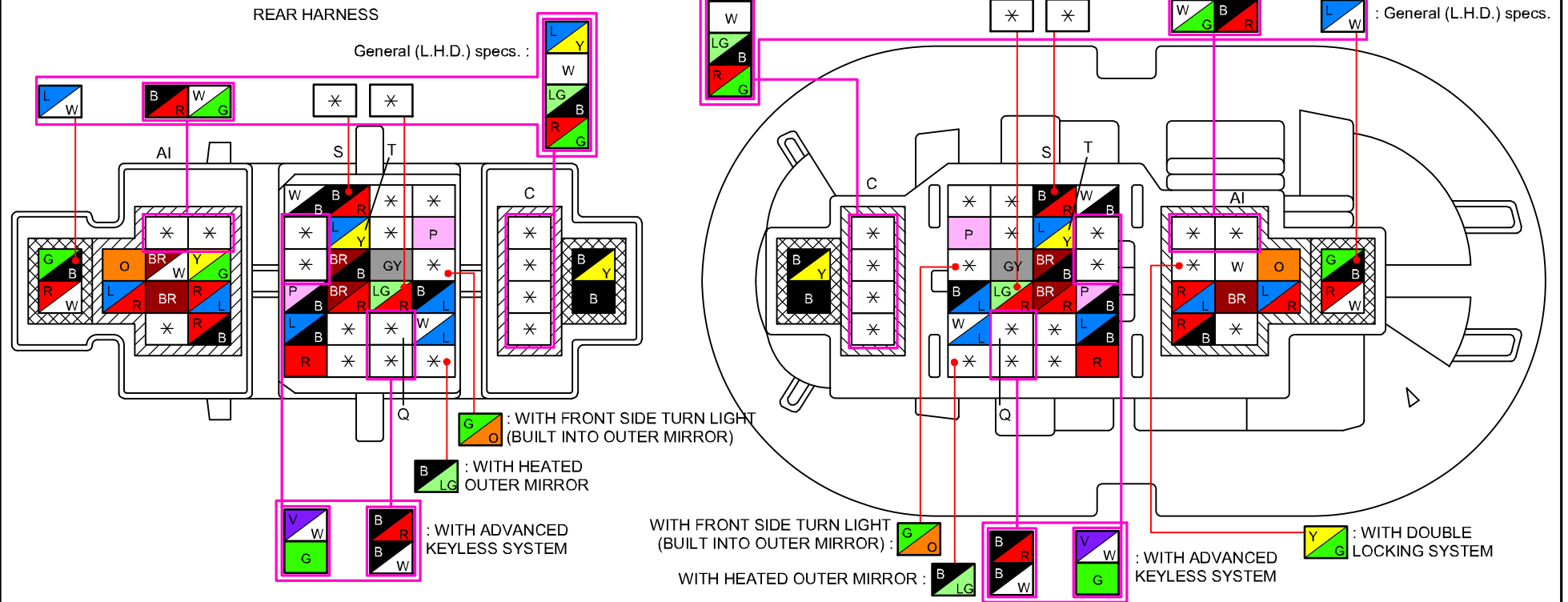

C-30

REAR HARNESS-DOOR NO.2 HARNESS

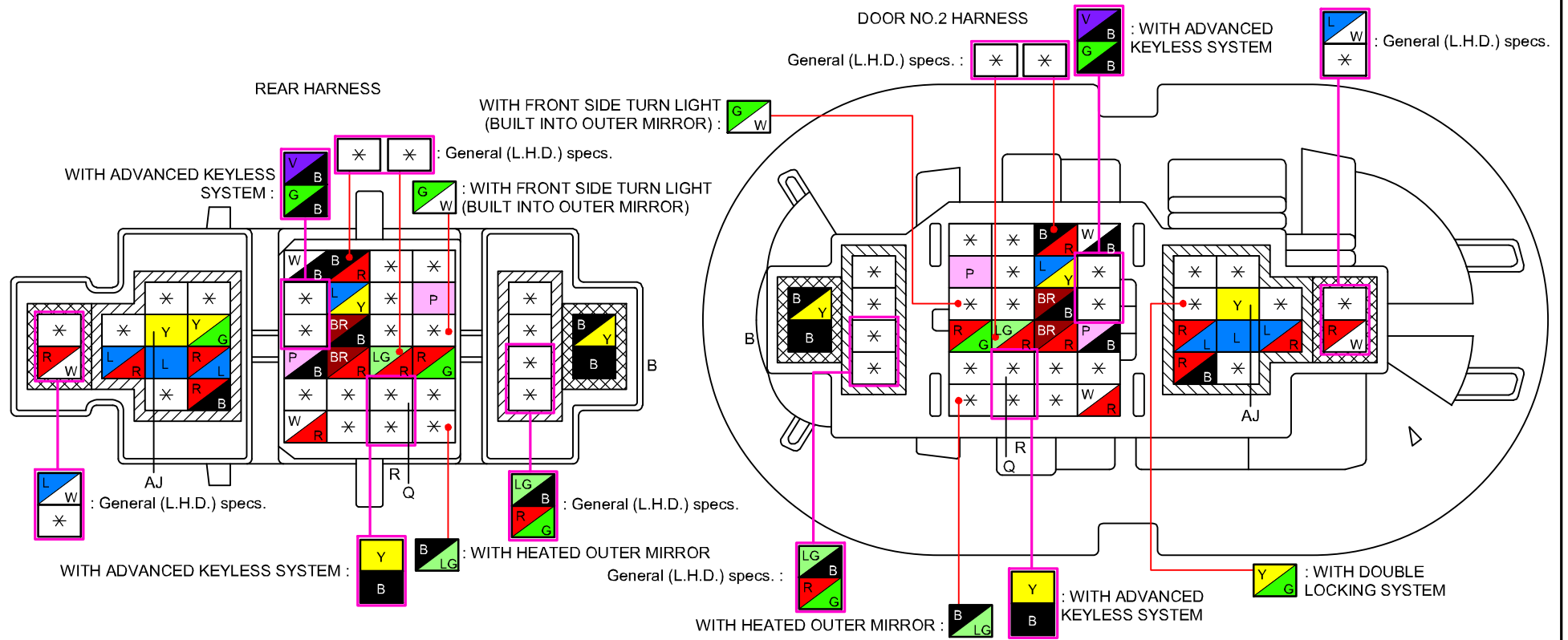

AUDIO SYSTEM (Bose® TYPE AUDIO)

0920-3g

- : INSTRUMENT PANEL HARNESS
- : REAR HARNESS
- : REAR NO.2 HARNESS
- : REAR NO.3 HARNESS
- : REAR NO.4 HARNESS
- : REAR NO.5 HARNESS
- : DOOR HARNESS
- : INTERIOR LIGHT HARNESS
- : FLOOR HARNESS

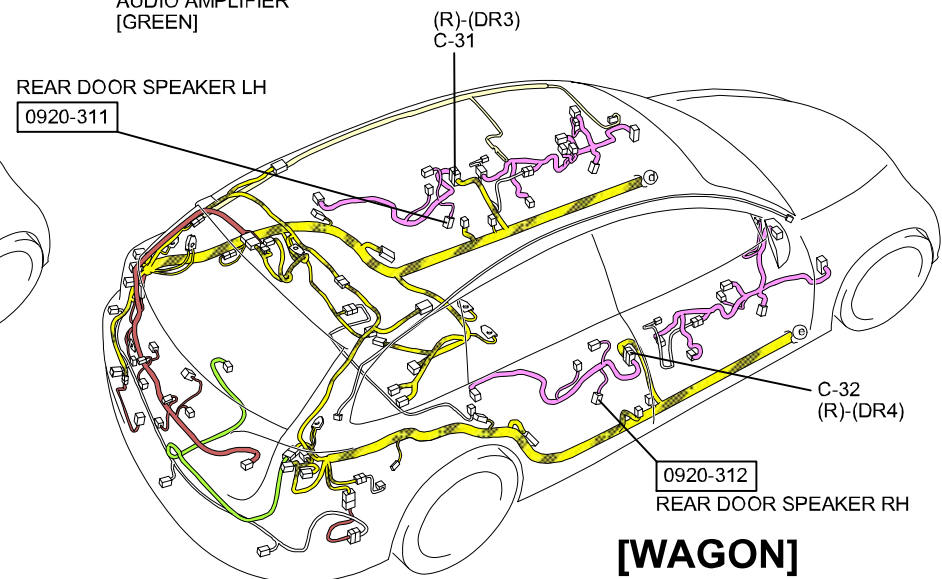
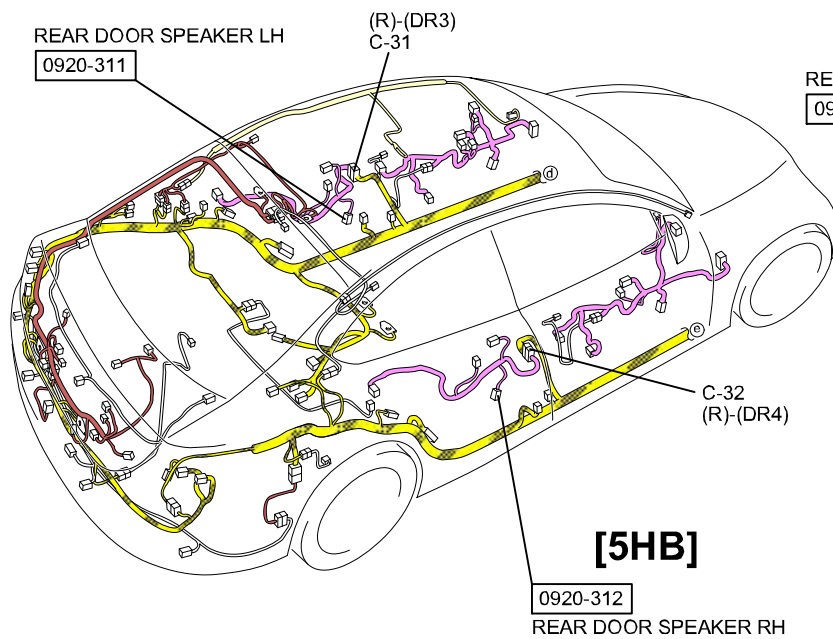
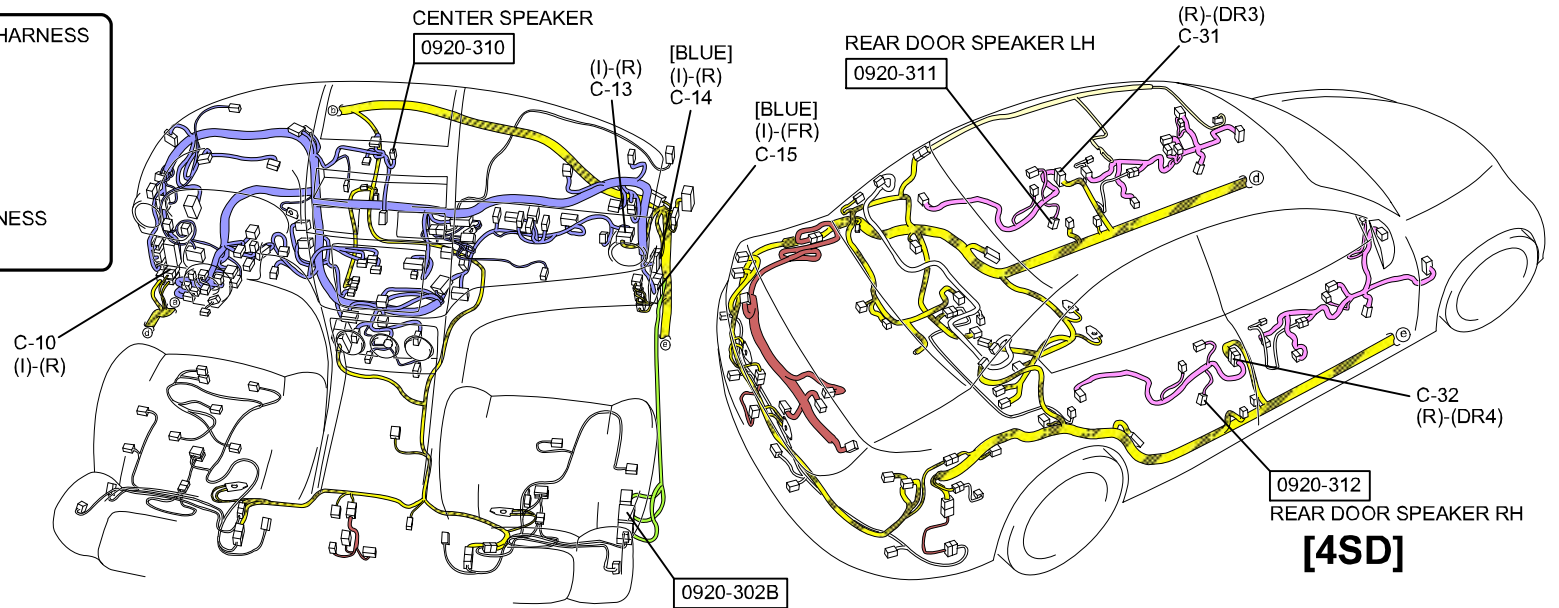

C-10
INSTRUMENT PANEL HARNESS-REAR HARNESS

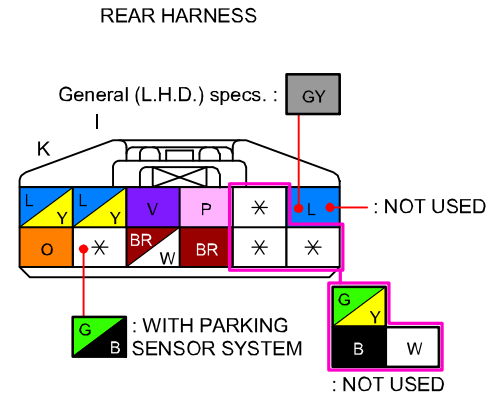
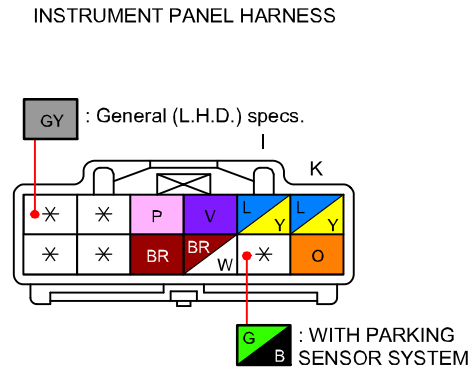

C-13
INSTRUMENT PANEL HARNESS-REAR HARNESS

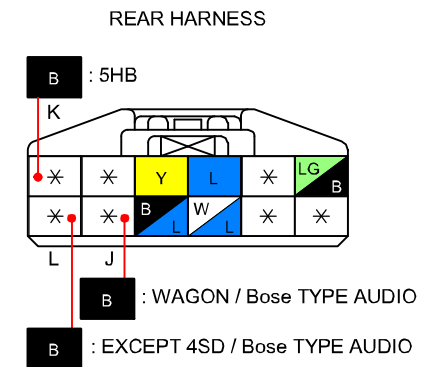
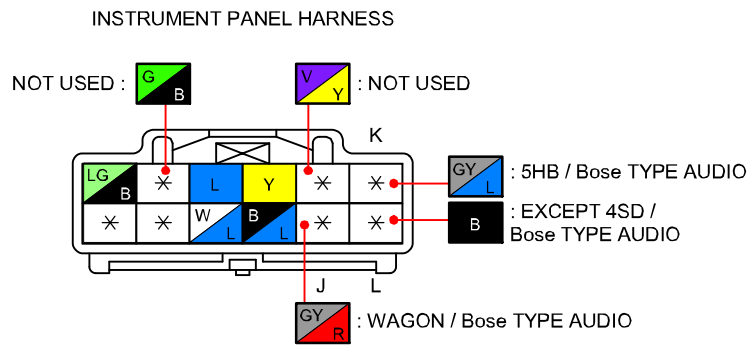

(WITHOUT ADVANCED KEYLESS SYSTEM)

C-14
INSTRUMENT PANEL HARNESS-REAR HARNESS

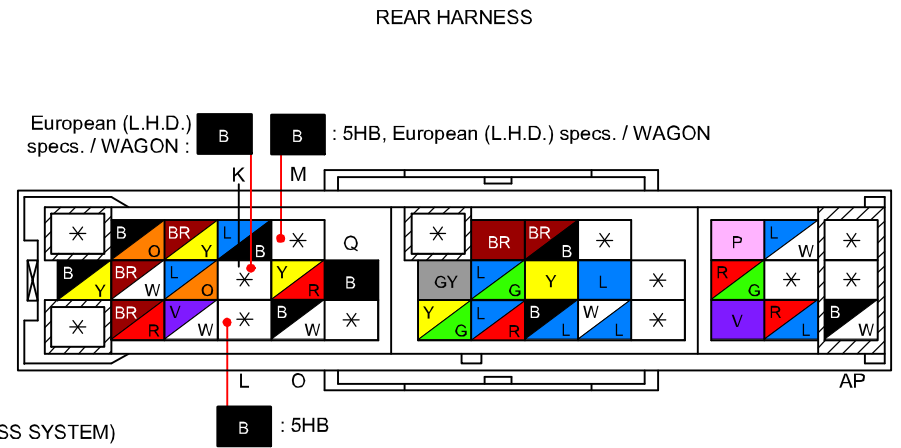
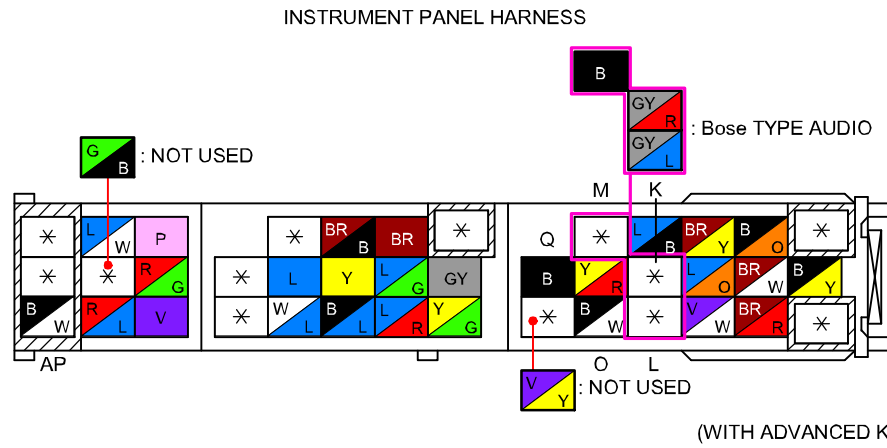

C-15
INSTRUMENT PANEL HARNESS-FLOOR HARNESS

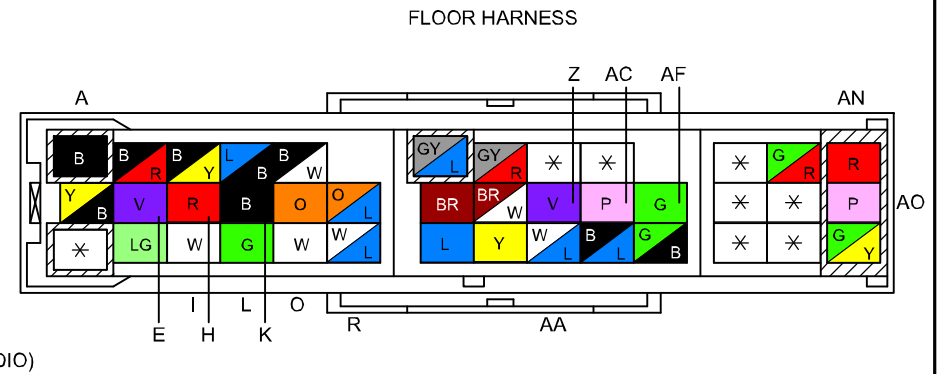
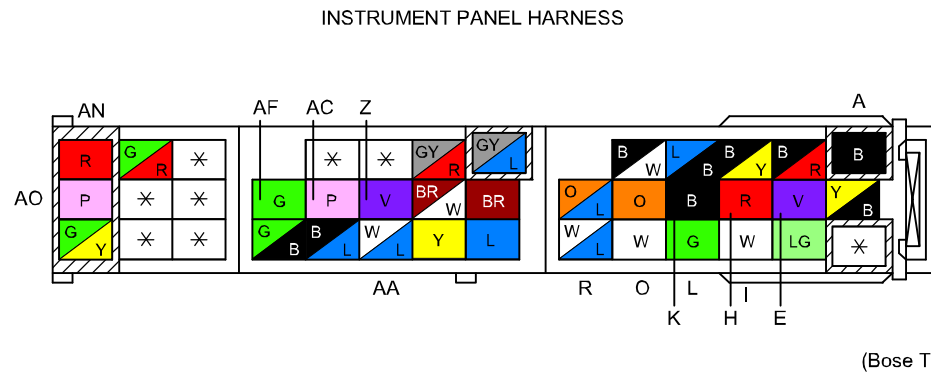

C-31
REAR HARNESS-DOOR NO.3 HARNESS

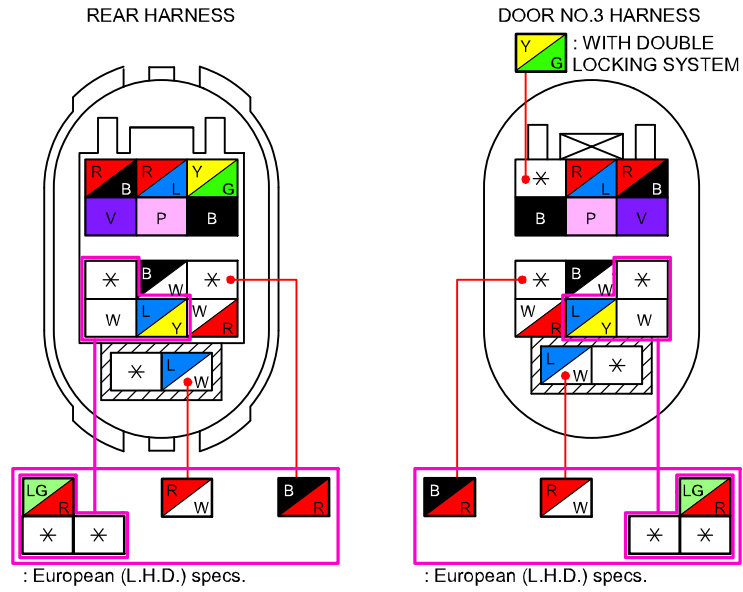

C-32
REAR HARNESS-DOOR NO.4 HARNESS

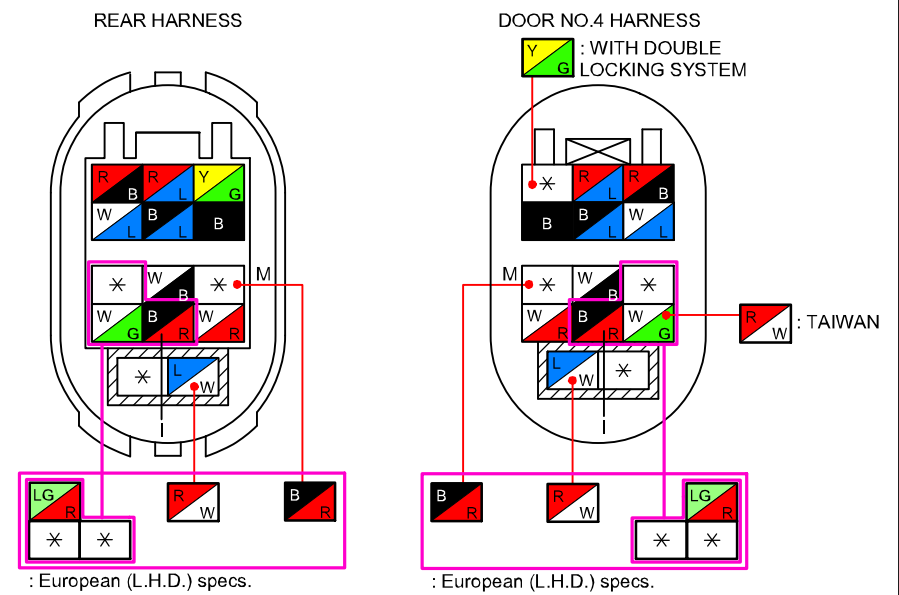

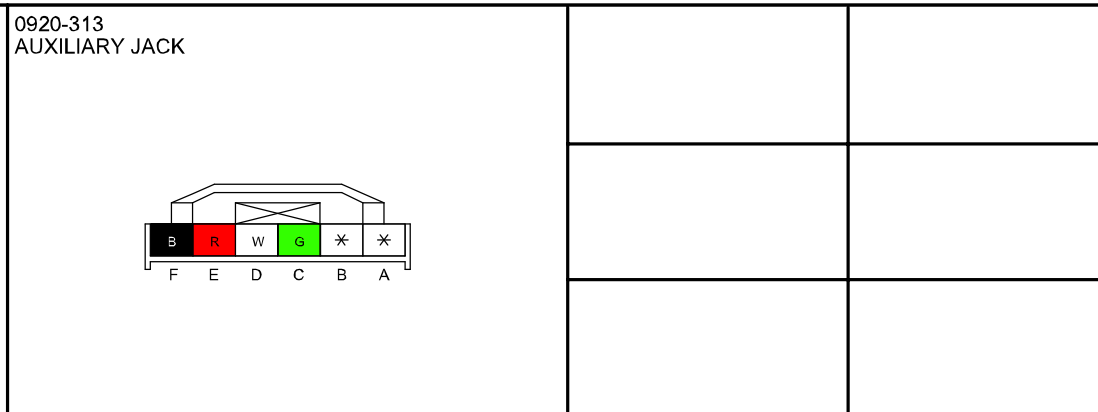
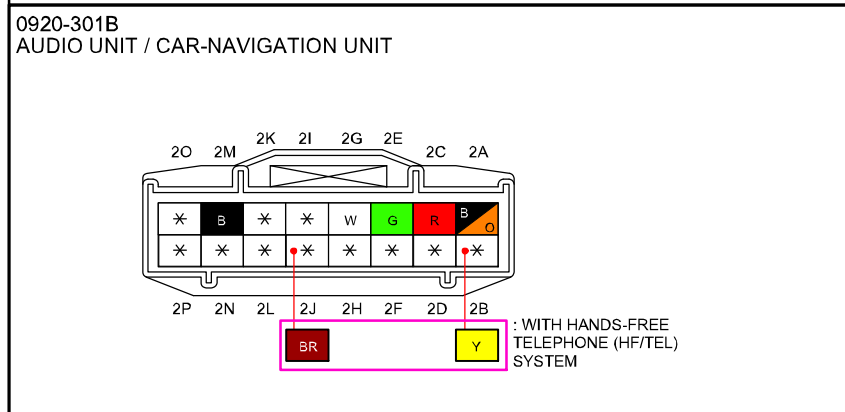
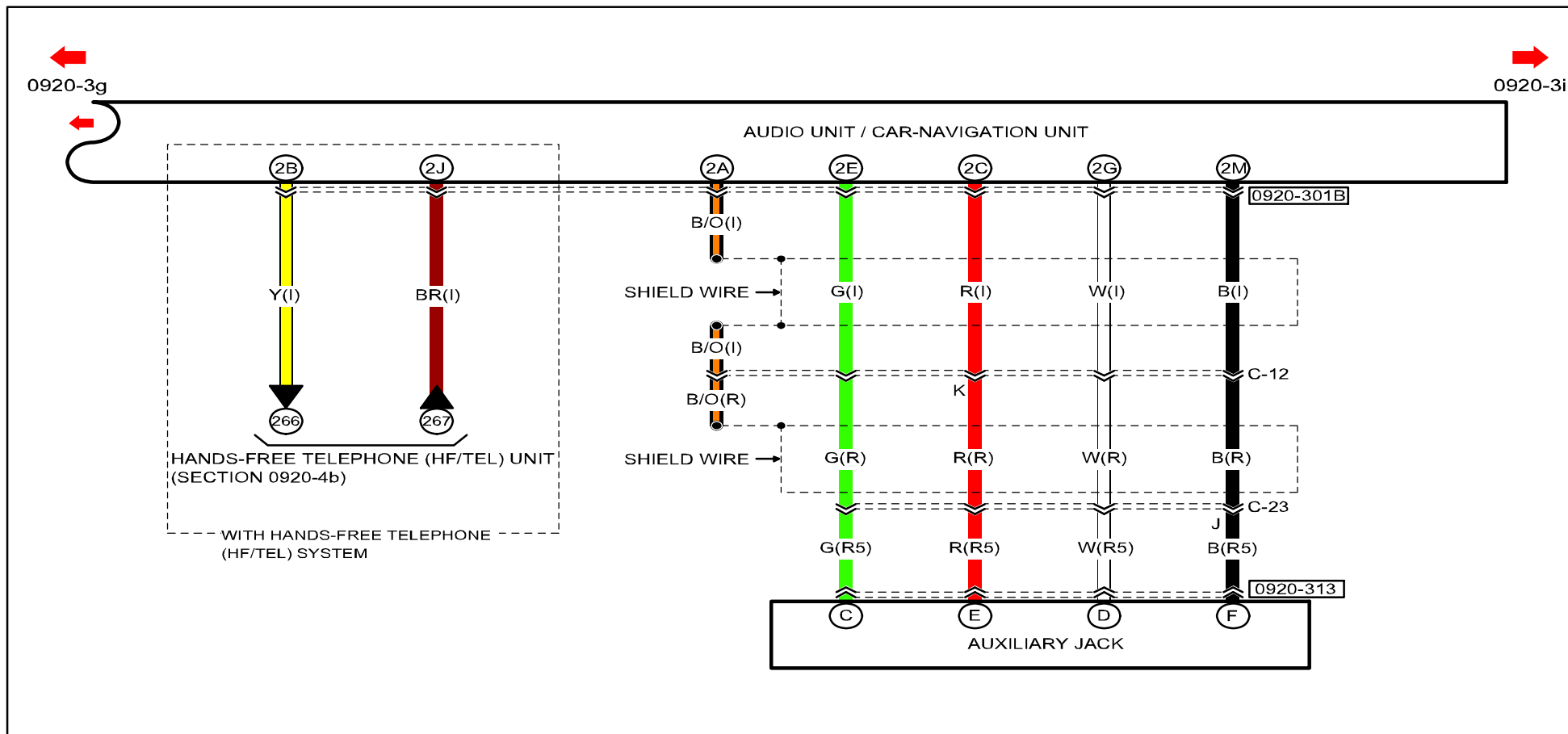

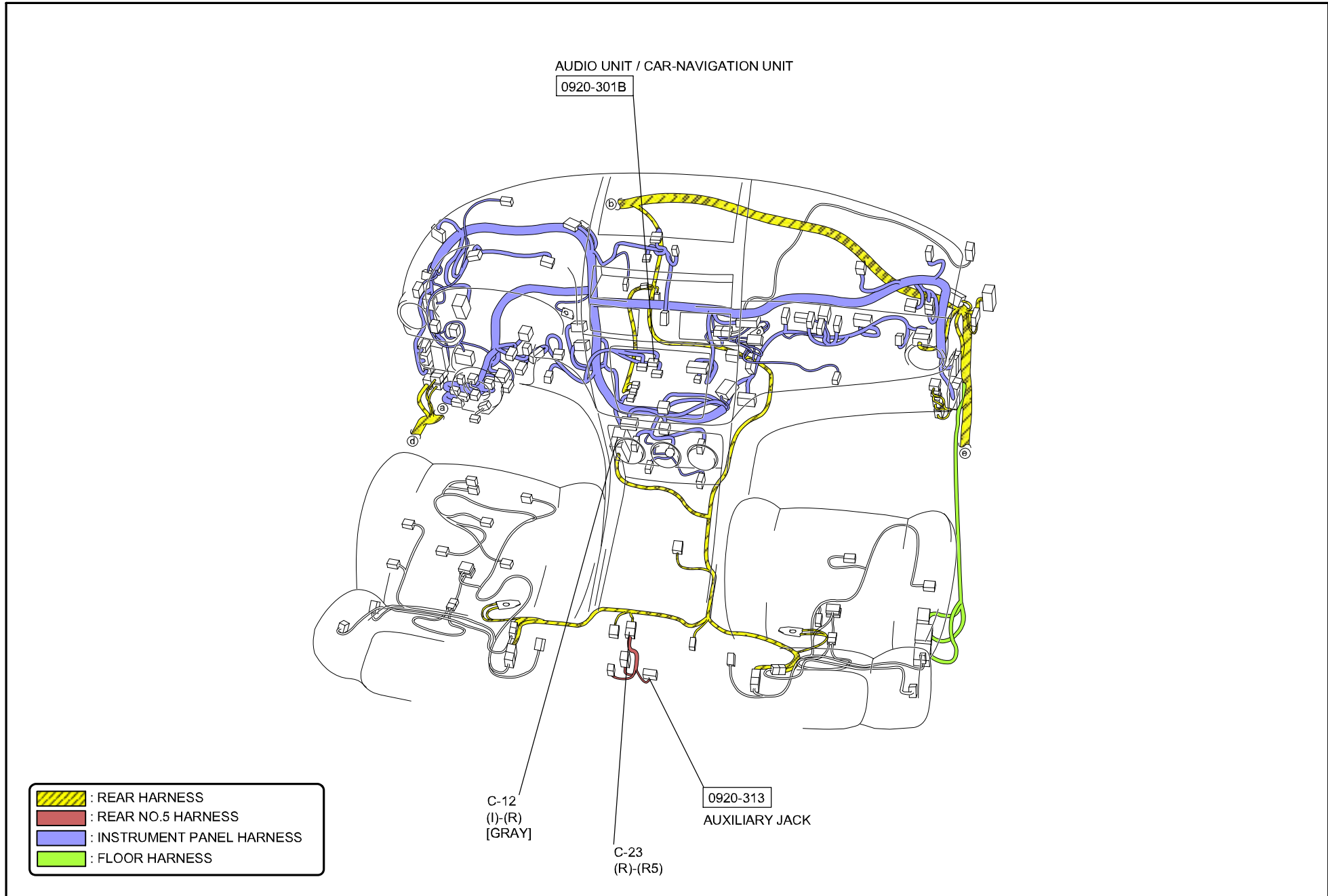

C-12
INSTRUMENT PANEL HARNESS-REAR HARNESS

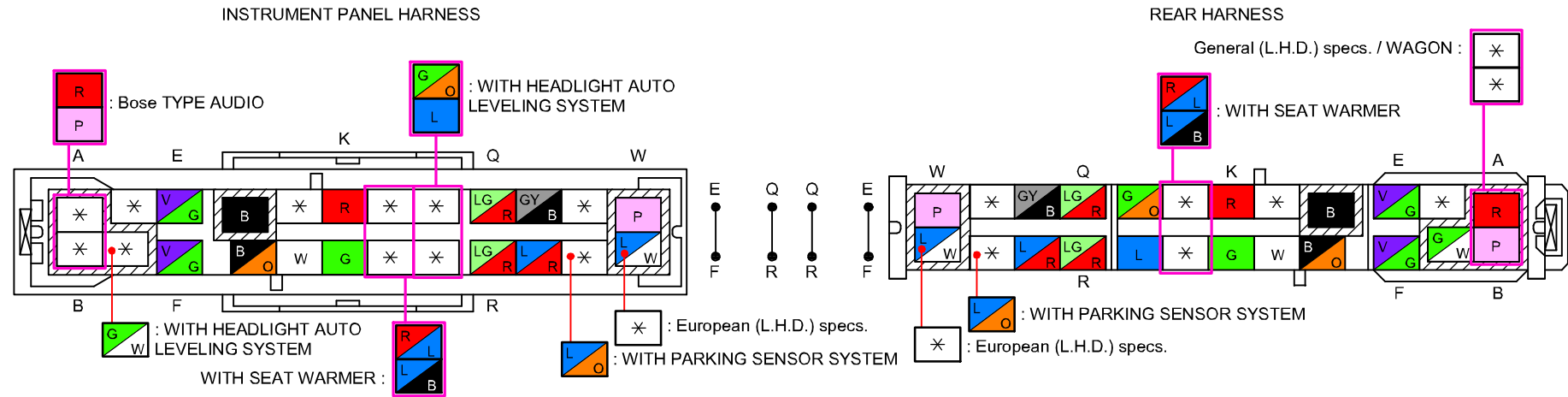

C-23
REAR HARNESS-REAR NO.5 HARNESS

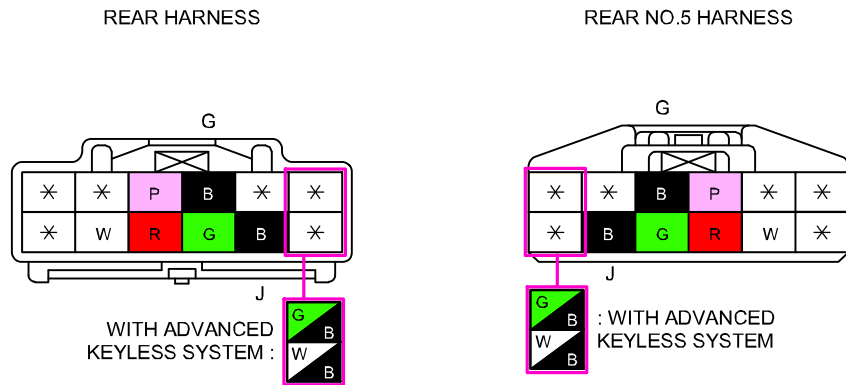

<> : WAGON

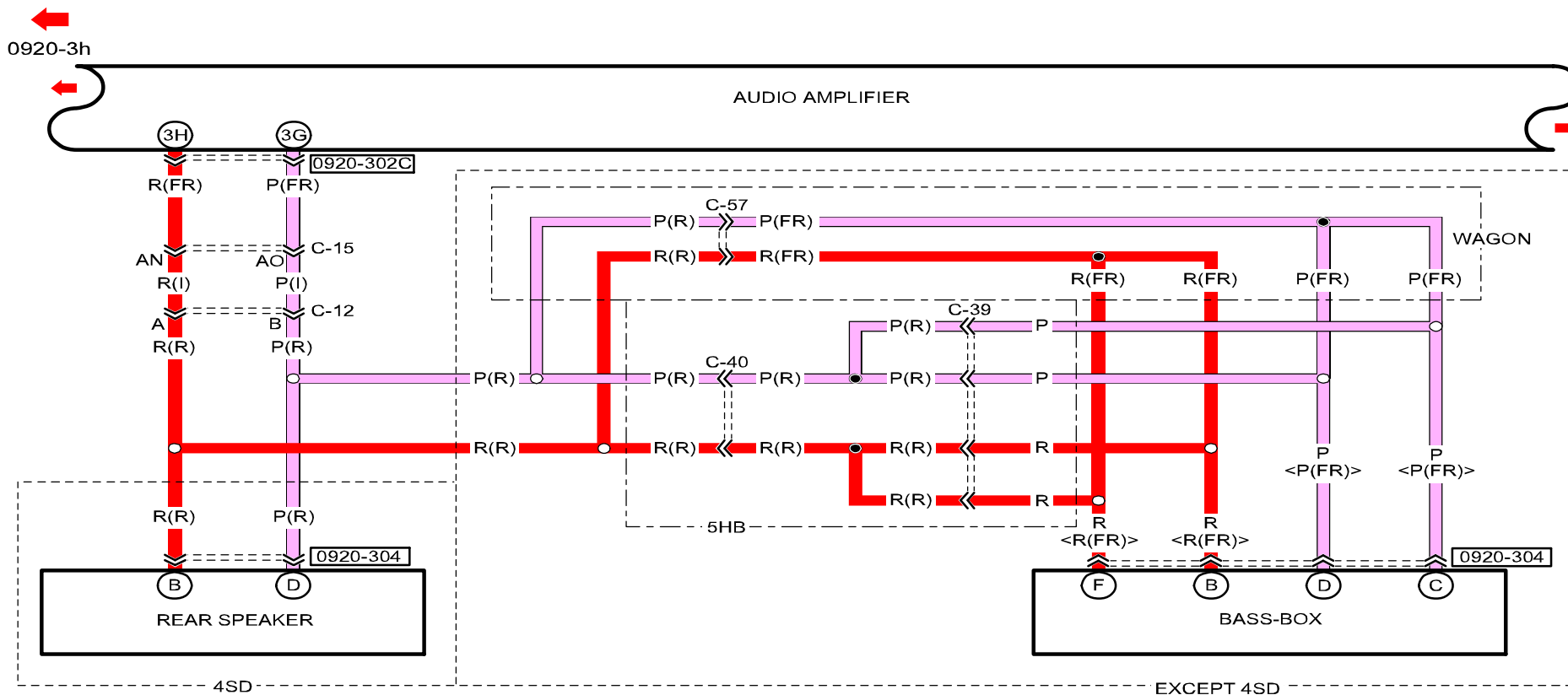

0920-302C
AUDIO AMPLIFIER

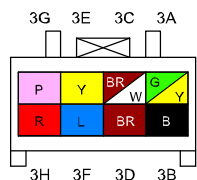

0920-304
REAR SPEAKER ← 4SD
BASS-BOX ← 5HB, WAGON

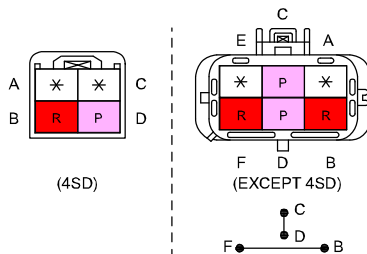

- : INSTRUMENT PANEL HARNESS
- : REAR HARNESS
- : REAR NO.2 HARNESS
- : REAR NO.3 HARNESS
- : REAR NO.4 HARNESS
- : REAR NO.5 HARNESS
- : DOOR HARNESS
- : INTERIOR LIGHT HARNESS
- : FLOOR HARNESS

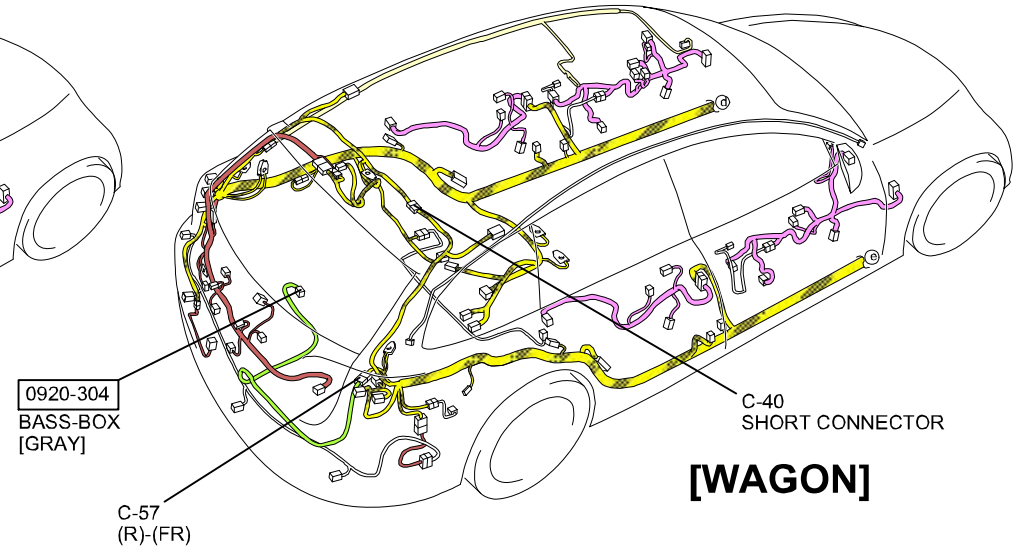
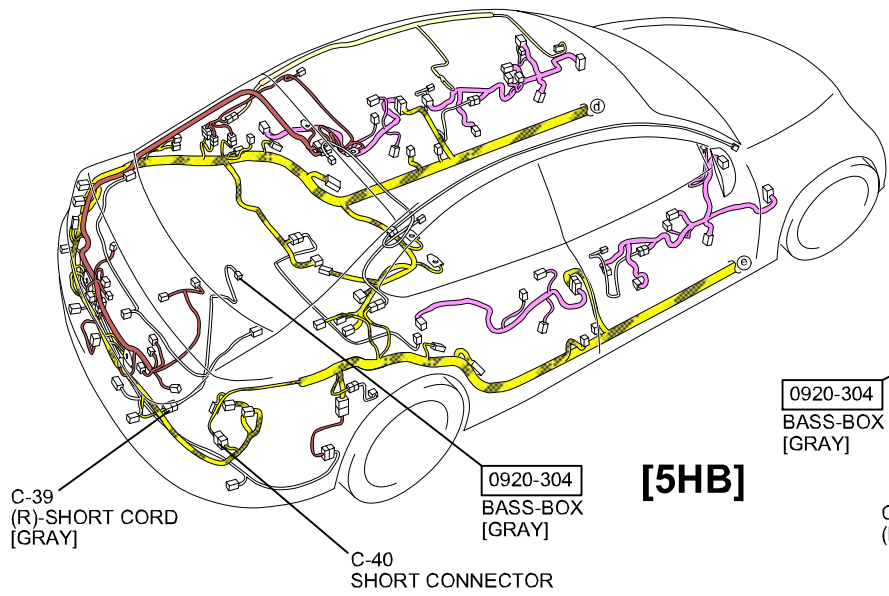
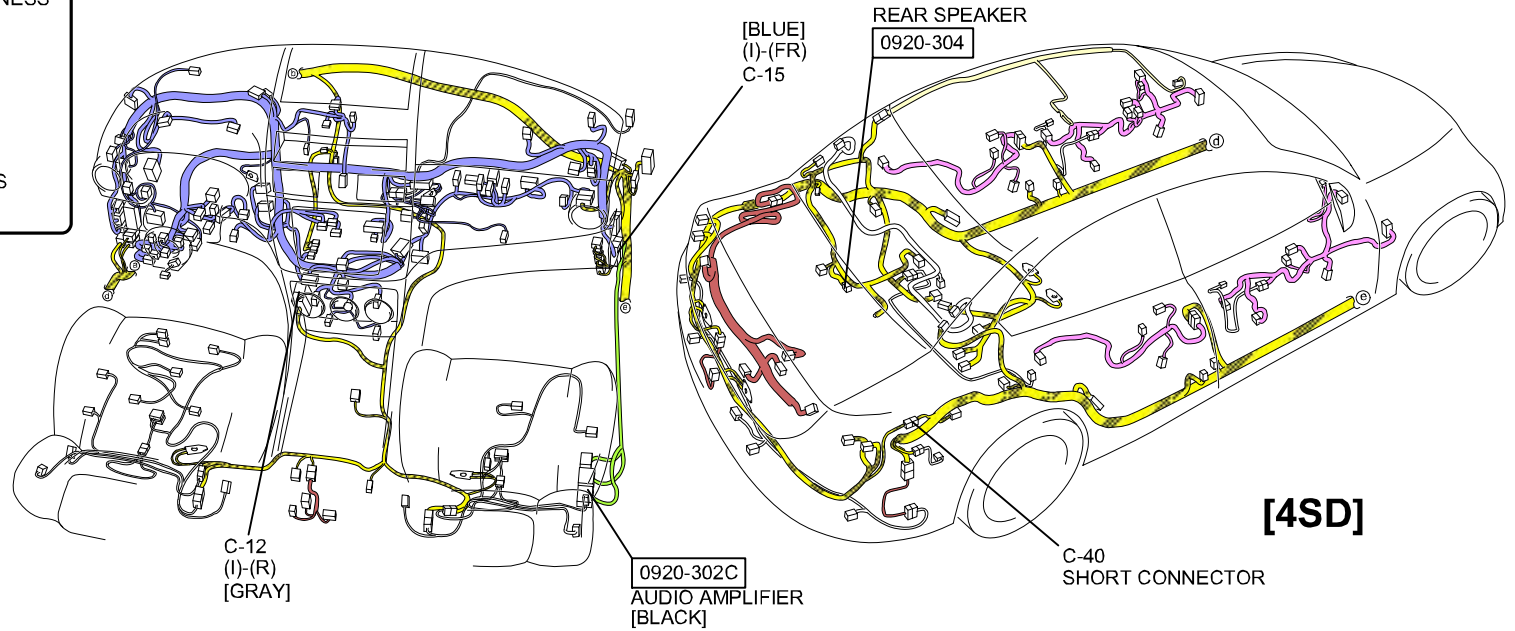

C-12
INSTRUMENT PANEL HARNESS-REAR HARNESS

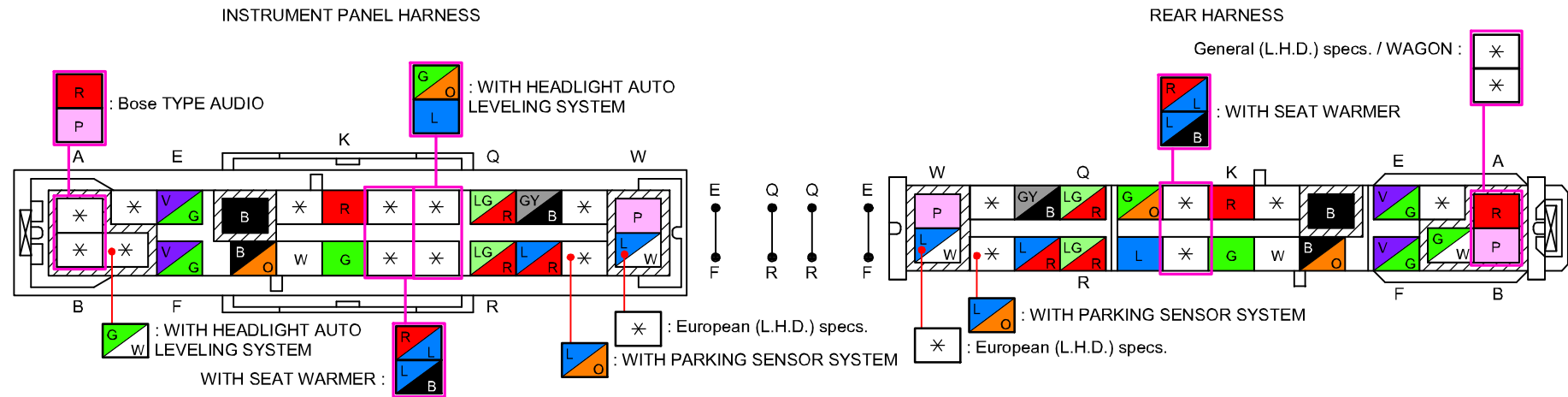

C-15
INSTRUMENT PANEL HARNESS-FLOOR HARNESS

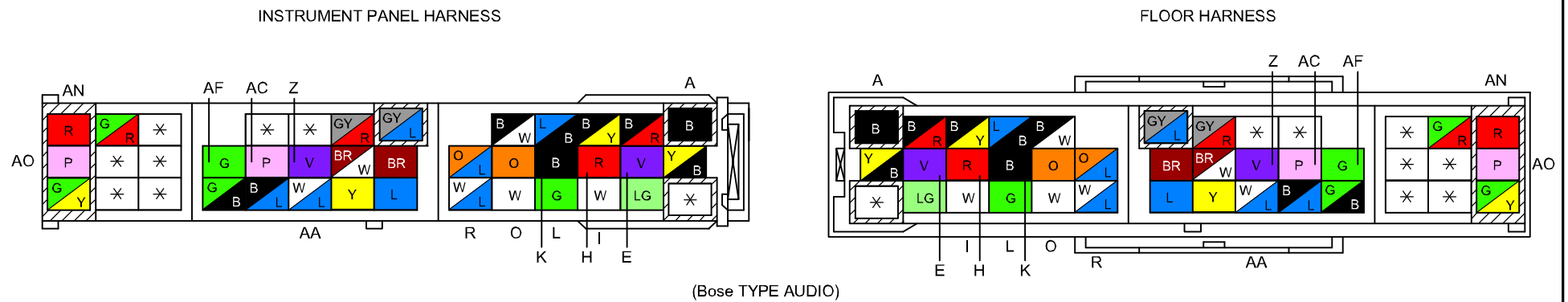

C-39
REAR HARNESS-SHORT CORD

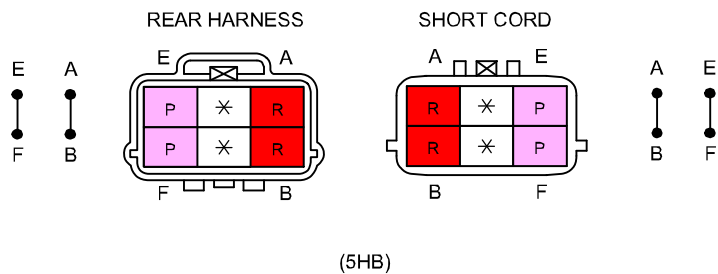

C-57
REAR HARNESS-FLOOR HARNESS

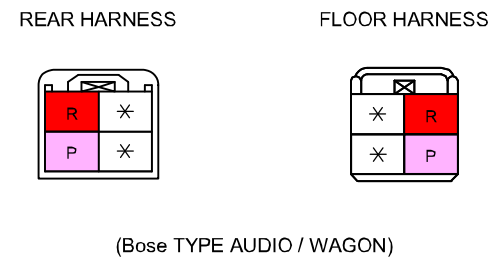

C-40
SHORT CONNECTOR

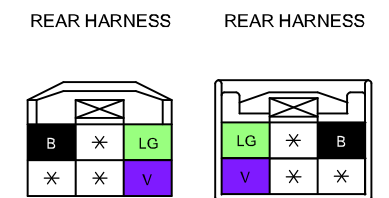

(4SD / WITH ADVANCED KEYLESS SYSTEM)

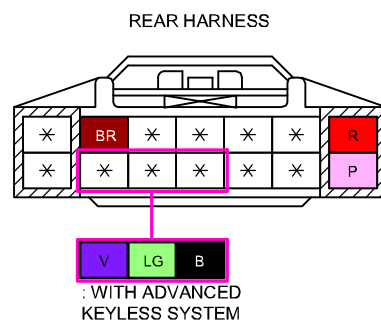

(5HB)

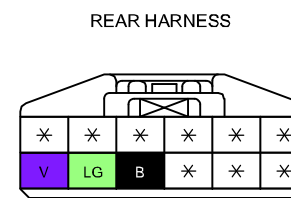
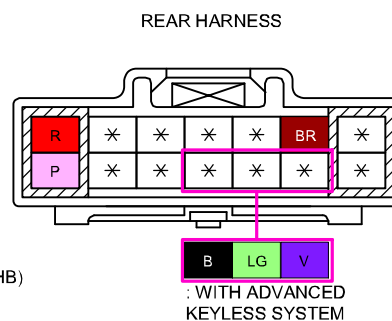

(WAGON / WITH ADVANCED KEYLESS SYSTEM)

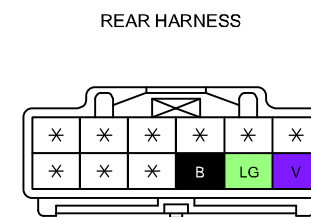

@1 : WITHOUT ADVANCED KEYLESS SYSTEM
 @2 : WITH ADVANCED KEYLESS SYSTEM

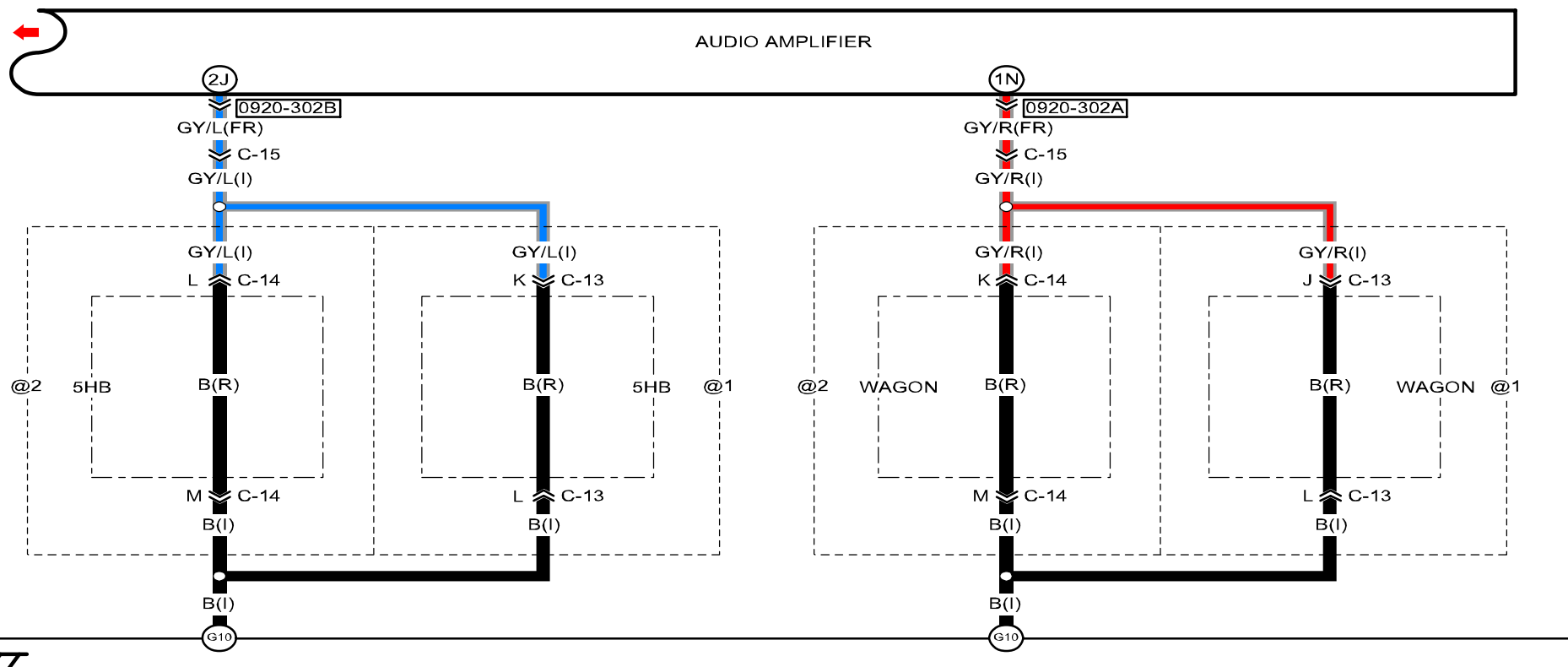

0920-302A
 AUDIO AMPLIFIER

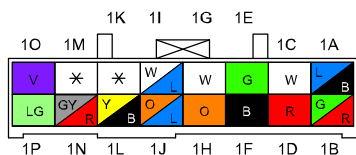

0920-302B
 AUDIO AMPLIFIER

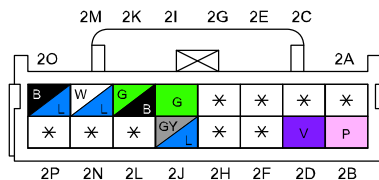

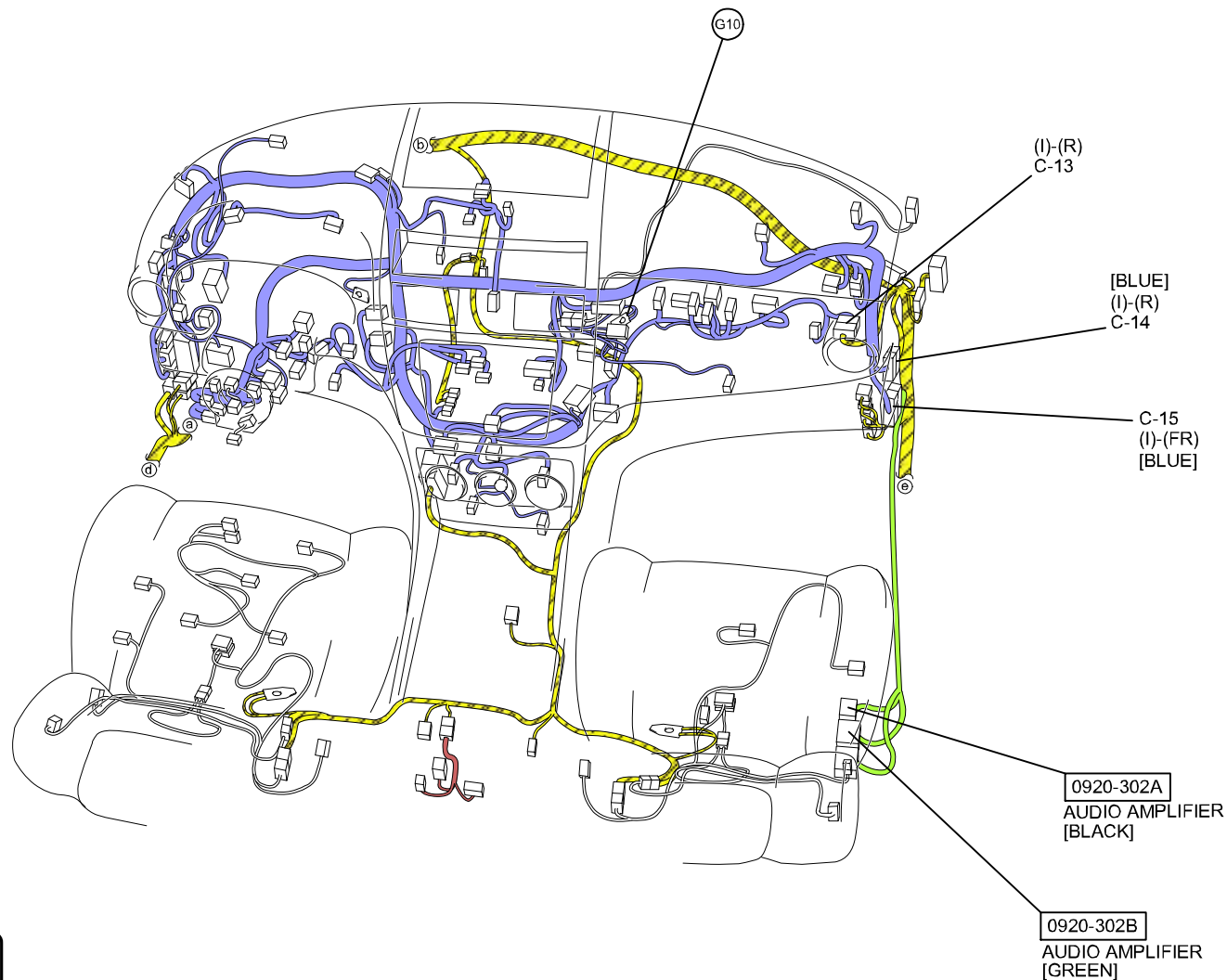

- [Yellow with diagonal stripes] : REAR HARNESS
- [Red] : REAR NO.5 HARNESS
- [Blue] : INSTRUMENT PANEL HARNESS
- [Green] : FLOOR HARNESS

C-13

INSTRUMENT PANEL HARNESS-REAR HARNESS

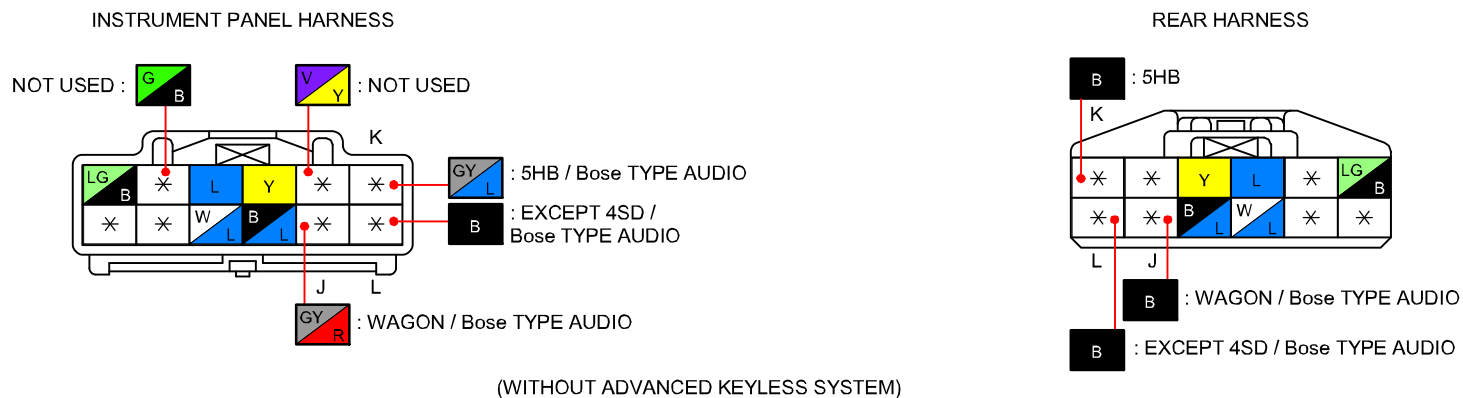

C-14

INSTRUMENT PANEL HARNESS-REAR HARNESS

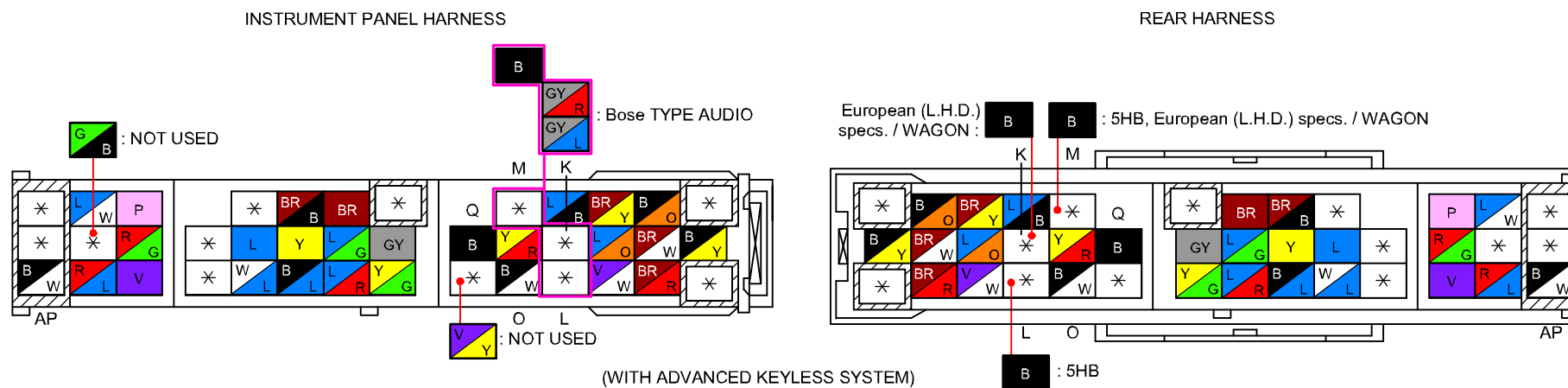

C-15

INSTRUMENT PANEL HARNESS-FLOOR HARNESS

INSTRUMENT PANEL HARNESS

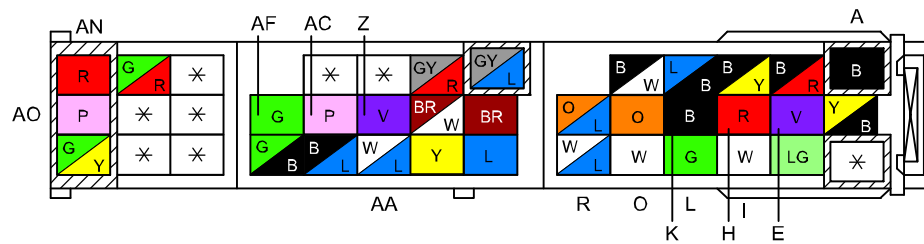

FLOOR HARNESS

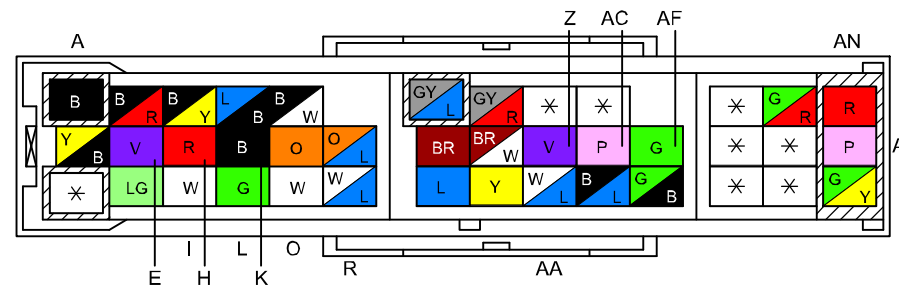

(Bose TYPE AUDIO)

HANDS-FREE TELEPHONE (HF/TEL) SYSTEM

0920-4a

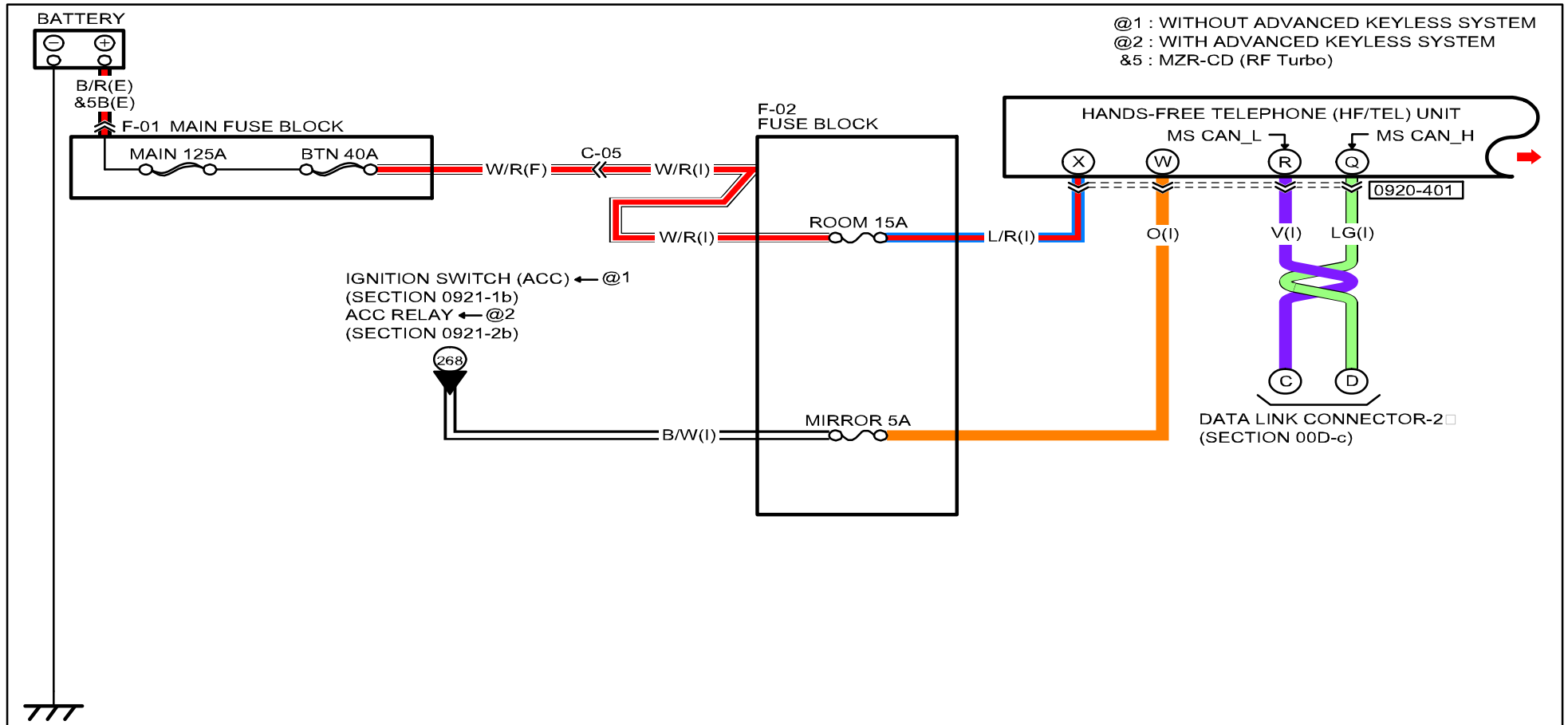

0920-401
HANDS-FREE TELEPHONE (HF/TEL) UNIT

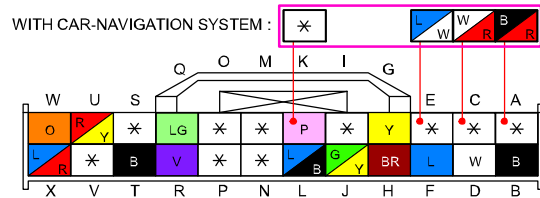

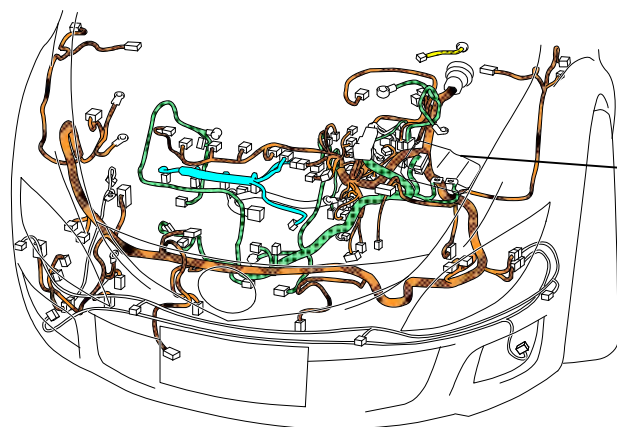

F-01
MAIN FUSE BLOCK
(REFER TO 00F SECTION)

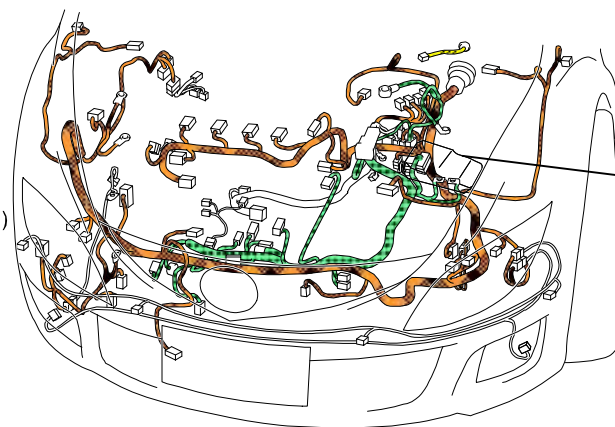

F-01
MAIN FUSE BLOCK
(REFER TO 00F SECTION)

[EXCEPT MZR-CD (RF Turbo)]

[MZR-CD (RF Turbo)]

HANDS-FREE TELEPHONE (HF/TEL)
UNIT
0920-401

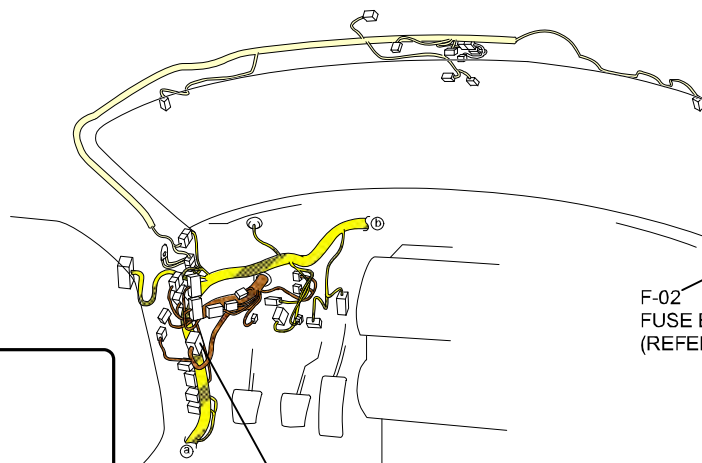





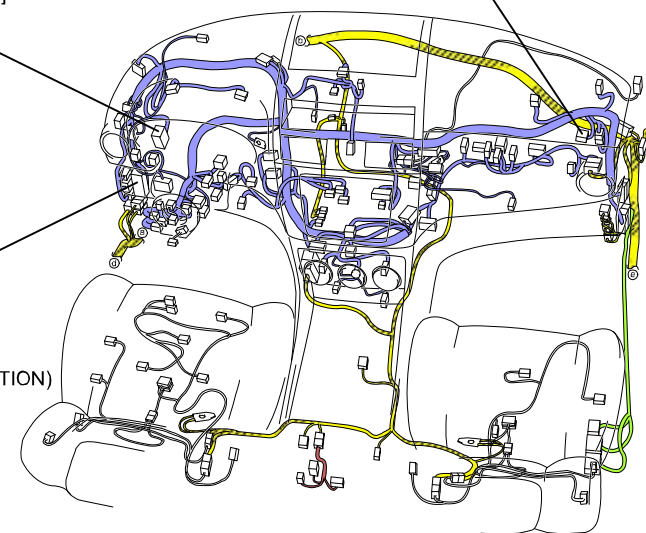



C-05
(F)-(I)
[BLUE]

F-02
FUSE BLOCK
(REFER TO 00F SECTION)



[BLUE]
(F)-(I)
C-05

-  : FRONT HARNESS
-  : ENGINE HARNESS
-  : INJECTION HARNESS
-  : REAR HARNESS
-  : REAR NO.5 HARNESS
-  : INSTRUMENT PANEL HARNESS
-  : FLOOR HARNESS
-  : INTERIOR LIGHT NO.2 HARNESS

C-05

FRONT HARNESS-INSTRUMENT PANEL HARNESS

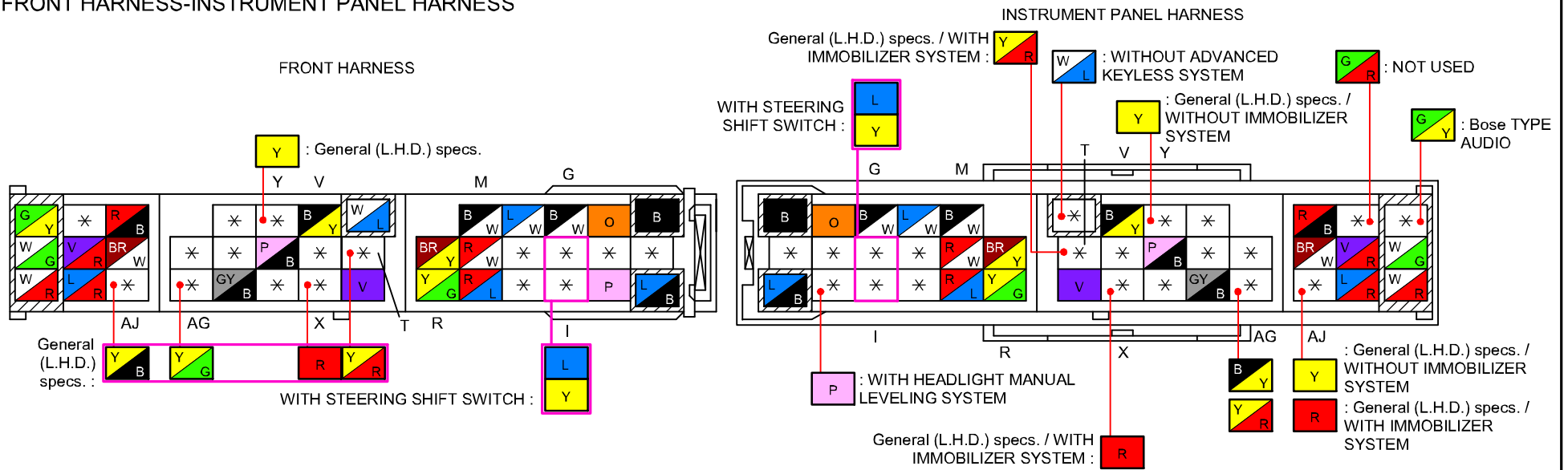

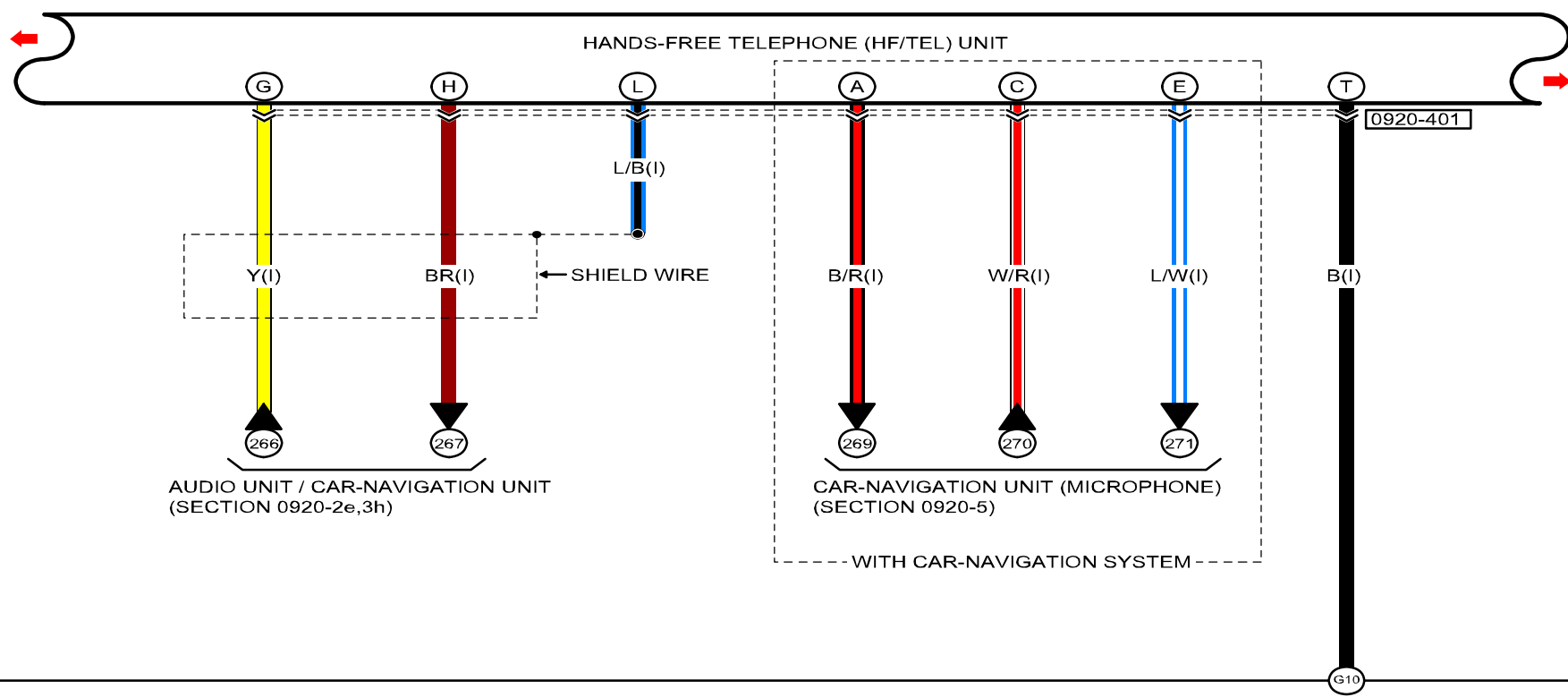

AUDIO UNIT / CAR-NAVIGATION UNIT
(SECTION 0920-2e,3h)

CAR-NAVIGATION UNIT (MICROPHONE)
(SECTION 0920-5)



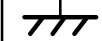

--- WITH CAR-NAVIGATION SYSTEM ---

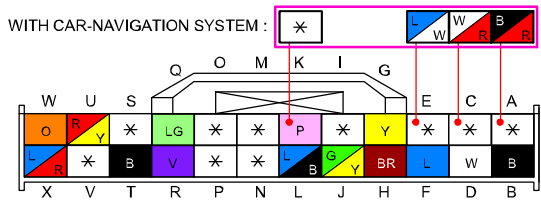

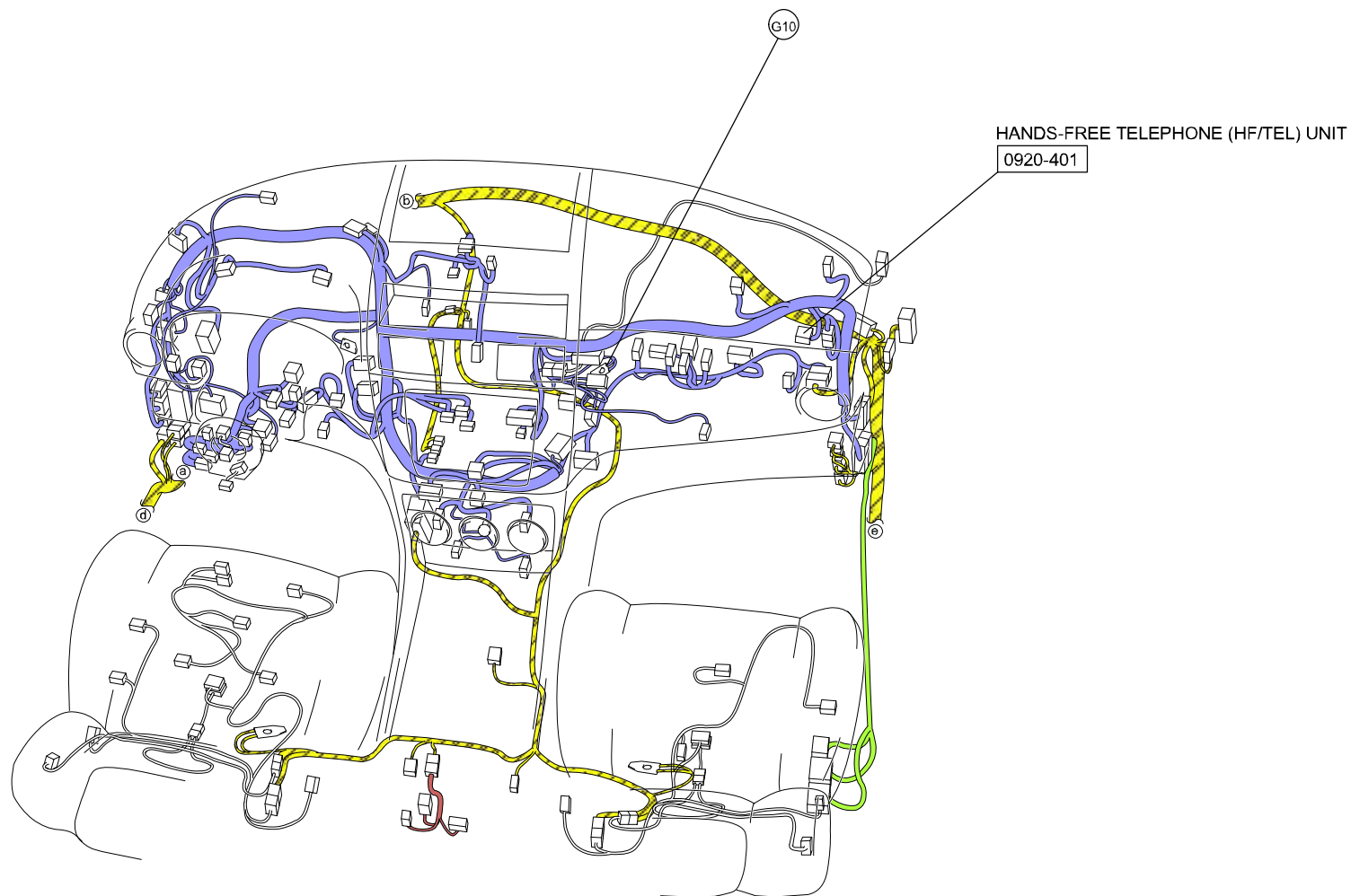
0920-401
HANDS-FREE TELEPHONE (HF/TEL) UNIT





-  : REAR HARNESS
-  : REAR NO.5 HARNESS
-  : INSTRUMENT PANEL HARNESS
-  : FLOOR HARNESS

&1 : WITHOUT CAR-NAVIGATION SYSTEM
&2 : WITH CAR-NAVIGATION SYSTEM

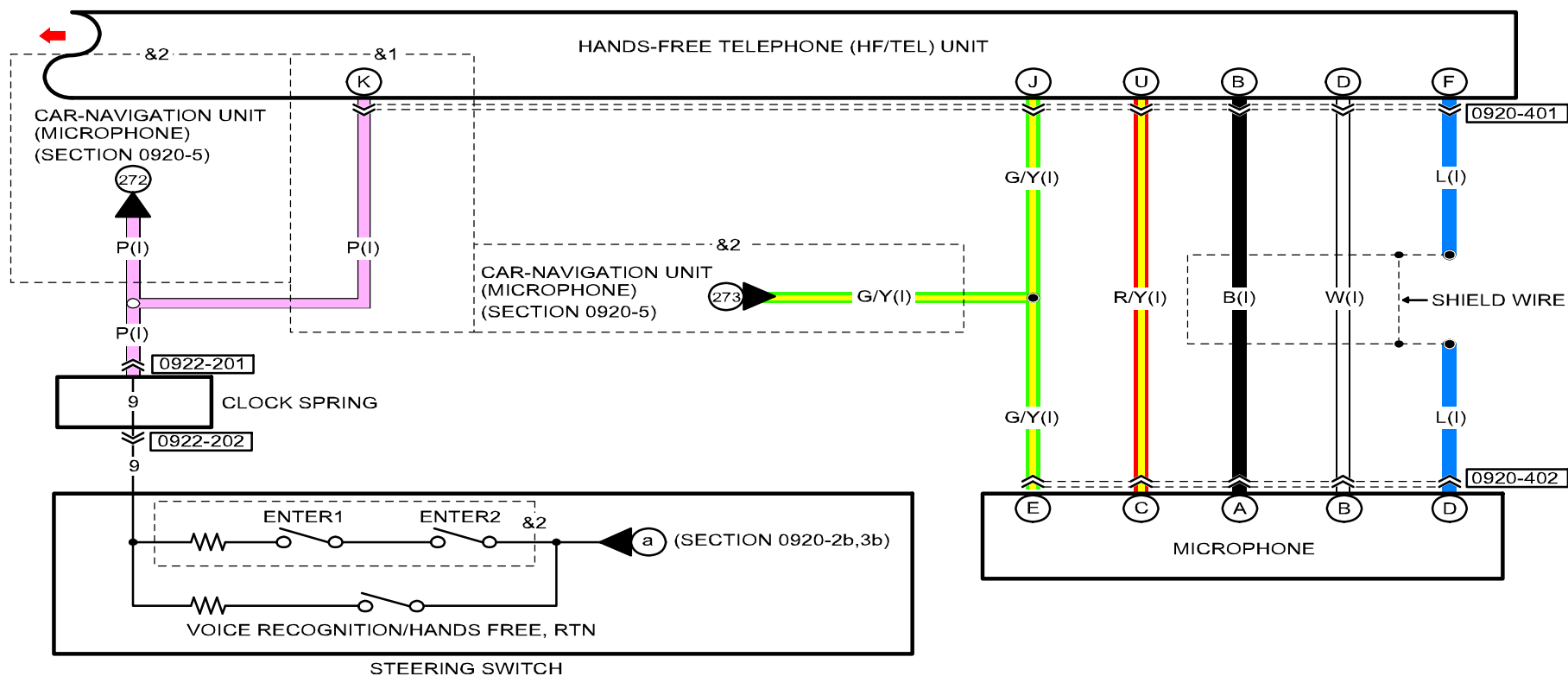

0920-401
HANDS-FREE TELEPHONE (HF/TEL) UNIT

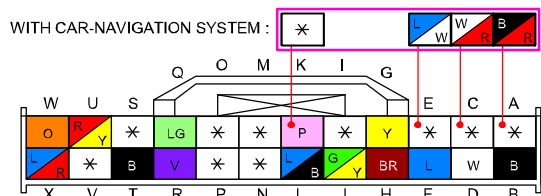

0920-402
MICROPHONE

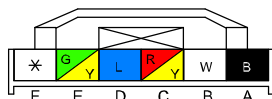

0922-202
CRUISE CONTROL SWITCH /
UP SWITCH / DOWN SWITCH /
STEERING SWITCH ILLUMINATION /
UP SWITCH ILLUMINATION /
DOWN SWITCH ILLUMINATION /
CRUISE CONTROL SWITCH ILLUMINATION /
STEERING SWITCH /
CLOCK SPRING

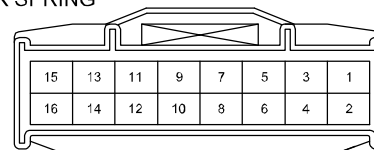

TERMINALS OF THIS CONNECTOR
ARE INDICATED BY NUMBERS.

0922-201
CLOCK SPRING

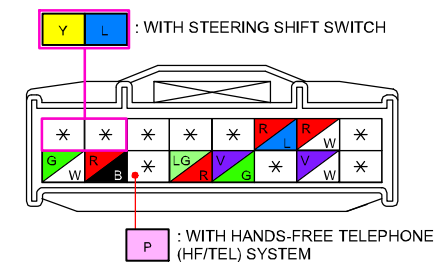

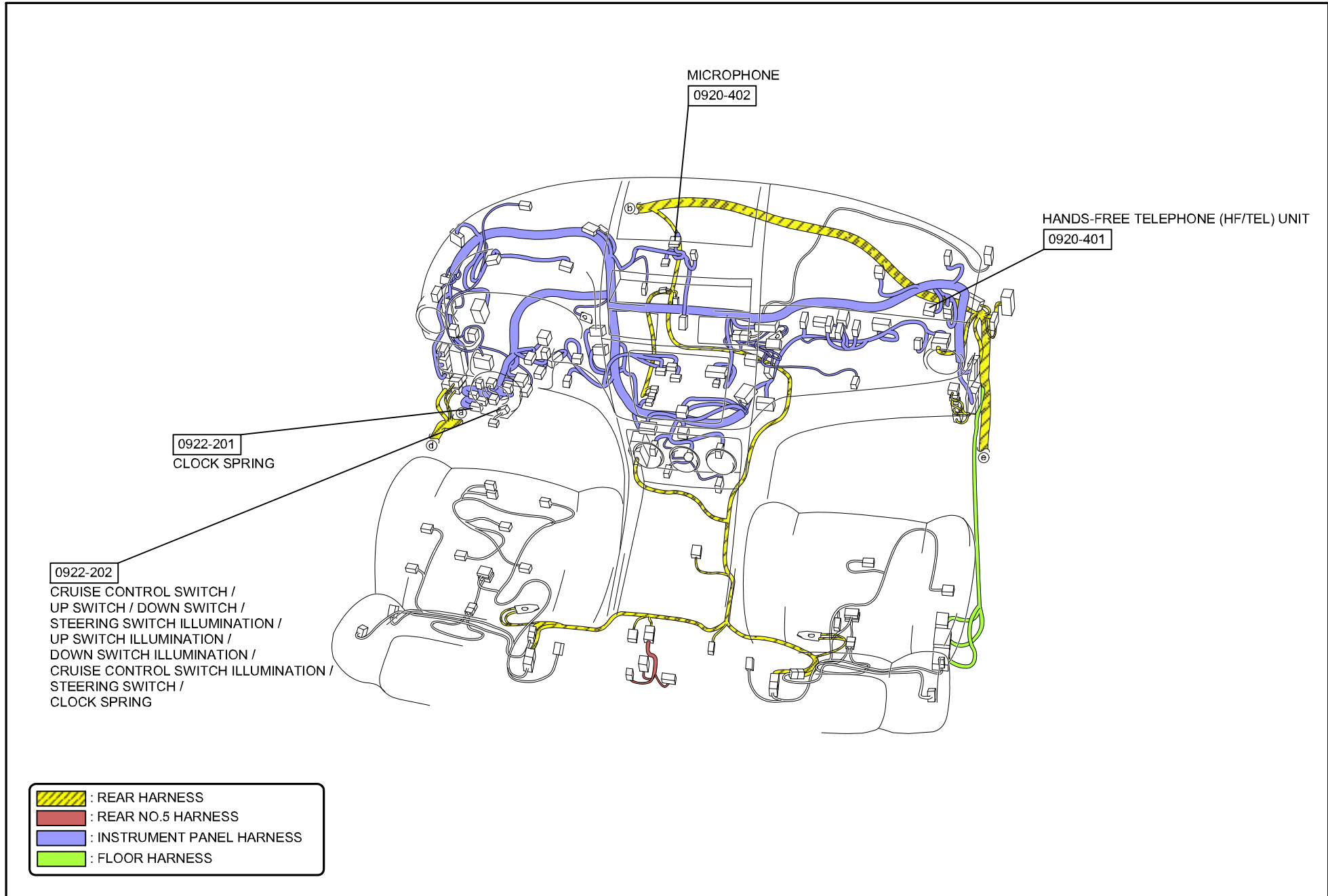

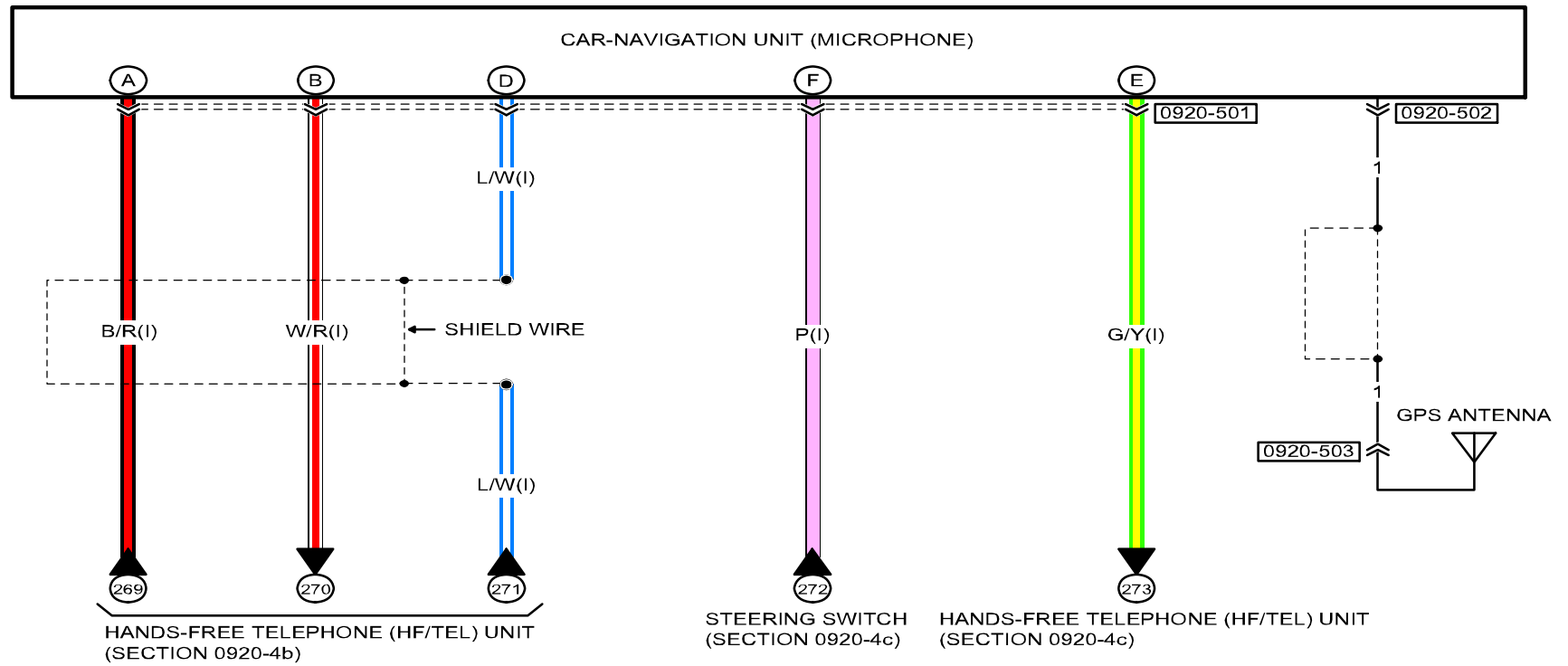

0920-501
CAR-NAVIGATION UNIT (MICROPHONE)

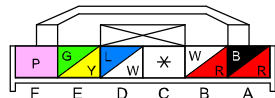

0920-502
CAR-NAVIGATION UNIT (MICROPHONE)

1





TERMINALS OF THIS CONNECTOR
ARE INDICATED BY NUMBERS.

0920-503
GPS ANTENNA

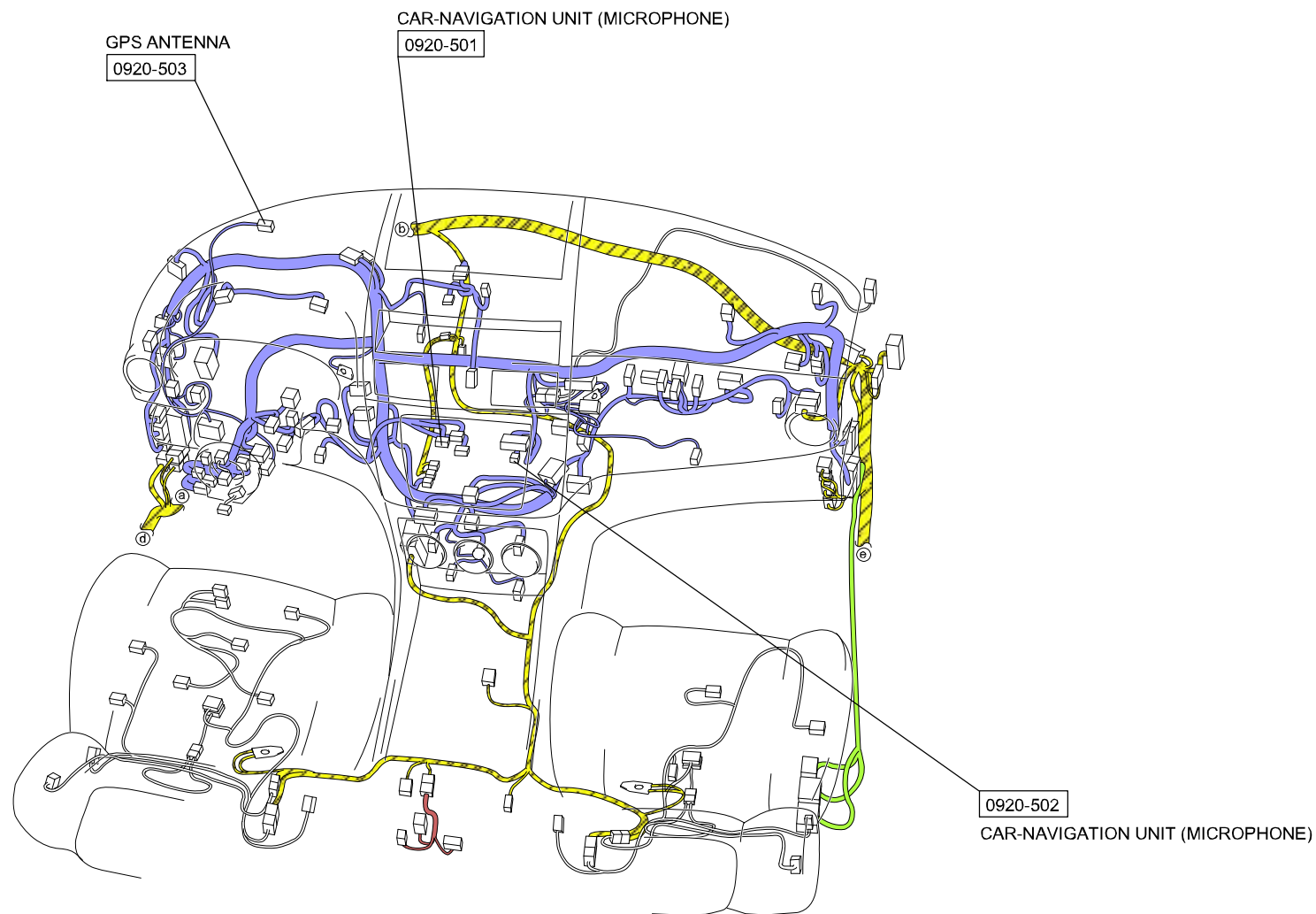
1

TERMINALS OF THIS CONNECTOR
ARE INDICATED BY NUMBERS.



-  : REAR HARNESS
-  : REAR NO.5 HARNESS
-  : INSTRUMENT PANEL HARNESS
-  : FLOOR HARNESS

POWER SYSTEM (WITHOUT ADVANCED KEYLESS SYSTEM)

0921-1a

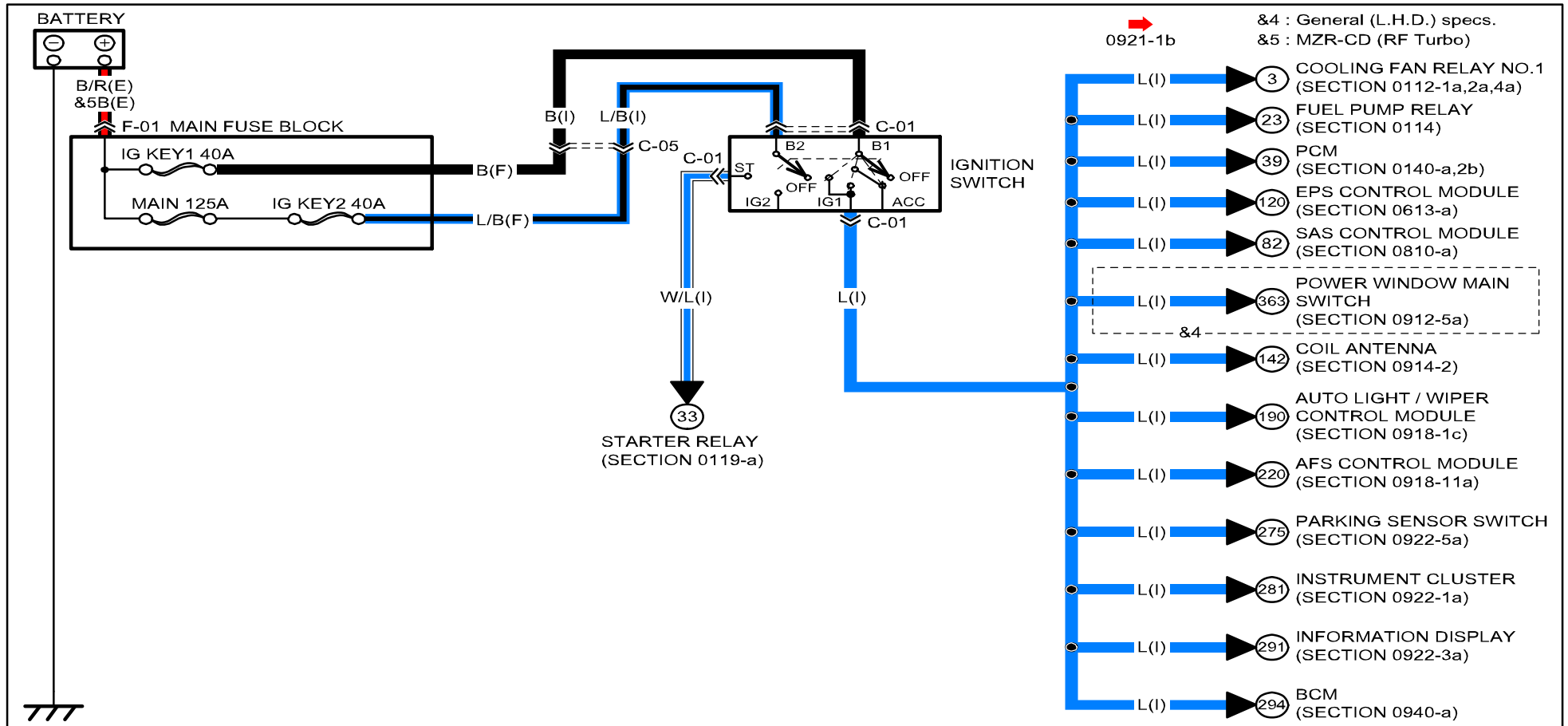

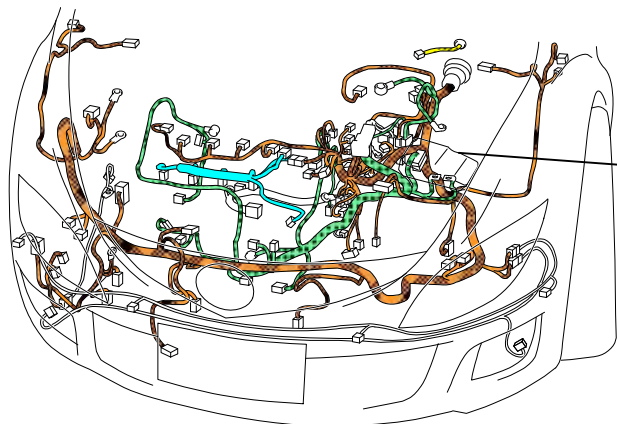

F-01
MAIN FUSE BLOCK
(REFER TO 00F SECTION)

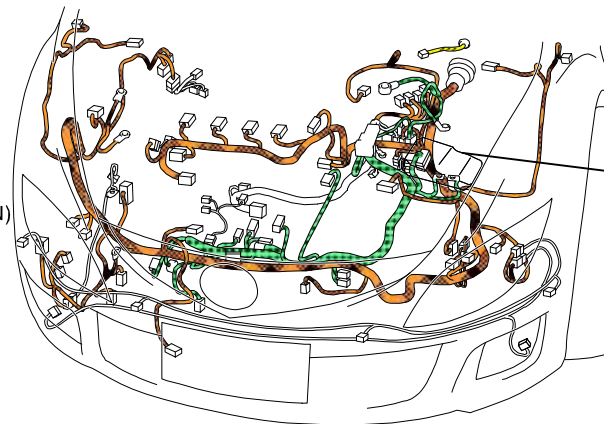

F-01
MAIN FUSE BLOCK
(REFER TO 00F SECTION)

[EXCEPT MZR-CD (RF Turbo)]

[MZR-CD (RF Turbo)]

IGNITION SWITCH
C-01

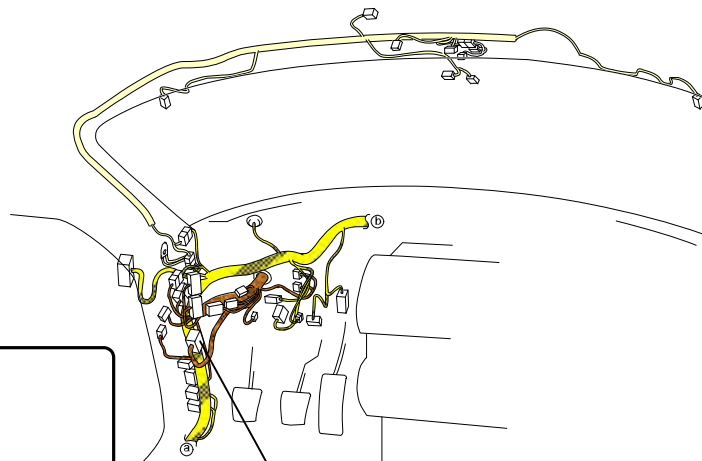

C-05
(F)-(I)
[BLUE]

[BLUE]
(F)-(I)
C-05

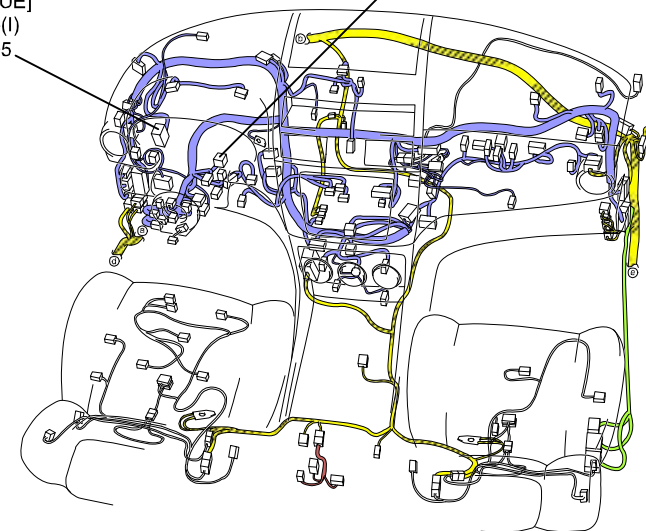

- : FRONT HARNESS
- : ENGINE HARNESS
- : INJECTION HARNESS
- : REAR HARNESS
- : REAR NO.5 HARNESS
- : INSTRUMENT PANEL HARNESS
- : FLOOR HARNESS
- : INTERIOR LIGHT NO.2 HARNESS

C-01
IGNITION SWITCH

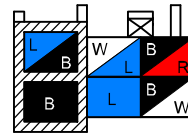

(WITHOUT ADVANCED KEYLESS SYSTEM)

C-05
FRONT HARNESS-INSTRUMENT PANEL HARNESS

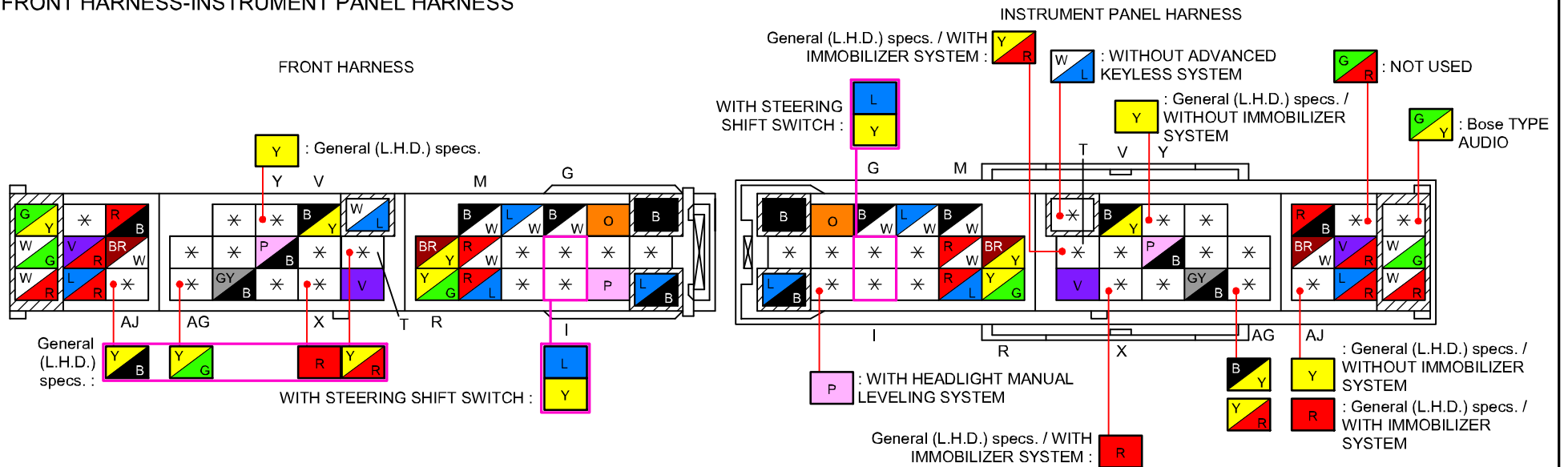

POWER SYSTEM (WITHOUT ADVANCED KEYLESS SYSTEM)

0921-1b

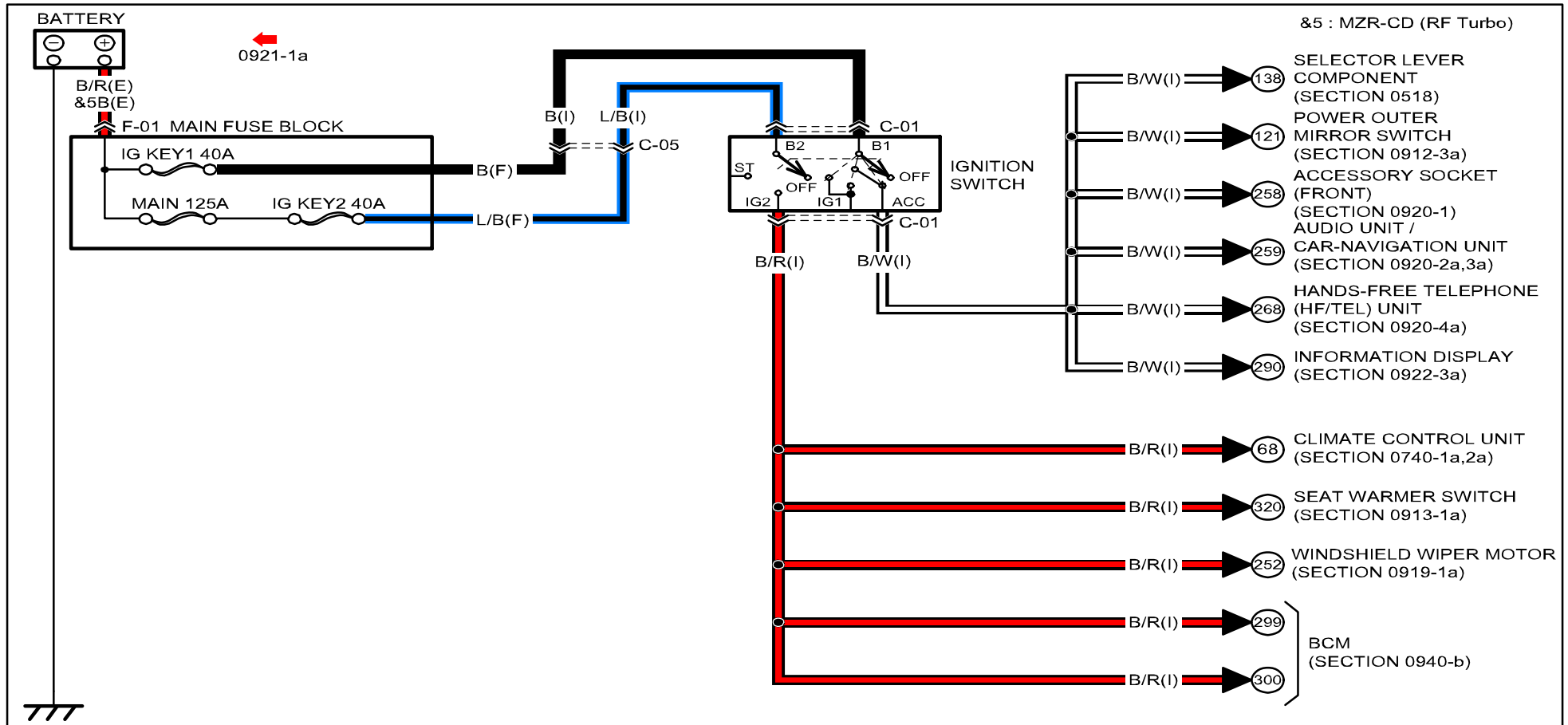

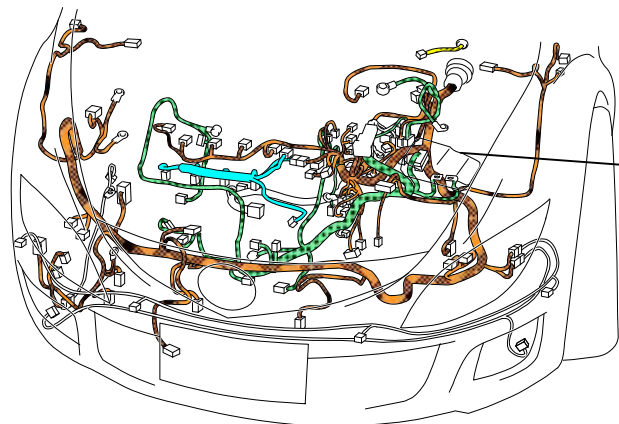

F-01
MAIN FUSE BLOCK
(REFER TO 00F SECTION)

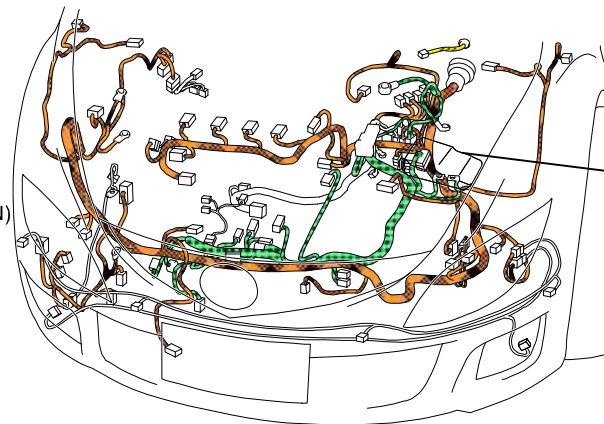

F-01
MAIN FUSE BLOCK
(REFER TO 00F SECTION)

[EXCEPT MZR-CD (RF Turbo)]

[MZR-CD (RF Turbo)]

IGNITION SWITCH
C-01

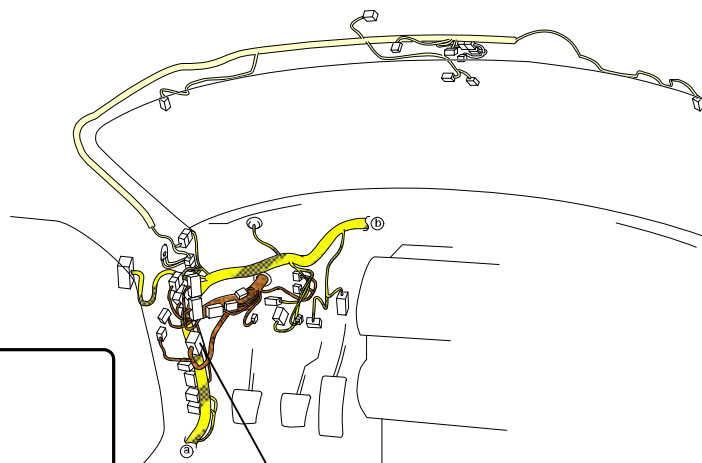

C-05
(F)-(I)
[BLUE]

[BLUE]
(F)-(I)
C-05

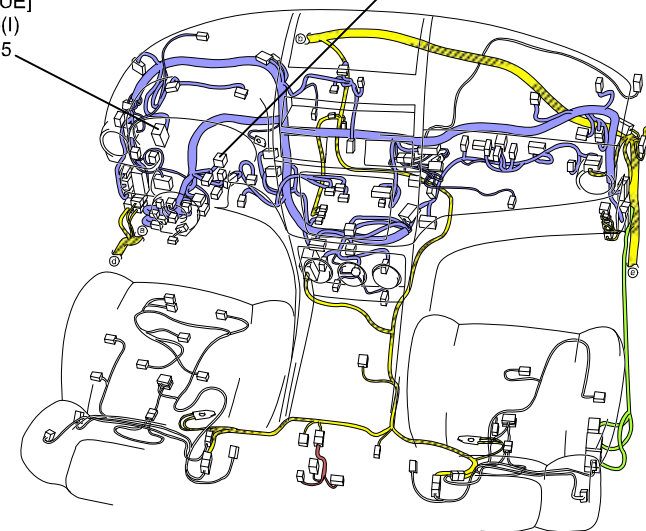

- : FRONT HARNESS
- : ENGINE HARNESS
- : INJECTION HARNESS
- : REAR HARNESS
- : REAR NO.5 HARNESS
- : INSTRUMENT PANEL HARNESS
- : FLOOR HARNESS
- : INTERIOR LIGHT NO.2 HARNESS

C-01
IGNITION SWITCH

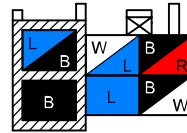

(WITHOUT ADVANCED KEYLESS SYSTEM)

C-05
FRONT HARNESS-INSTRUMENT PANEL HARNESS

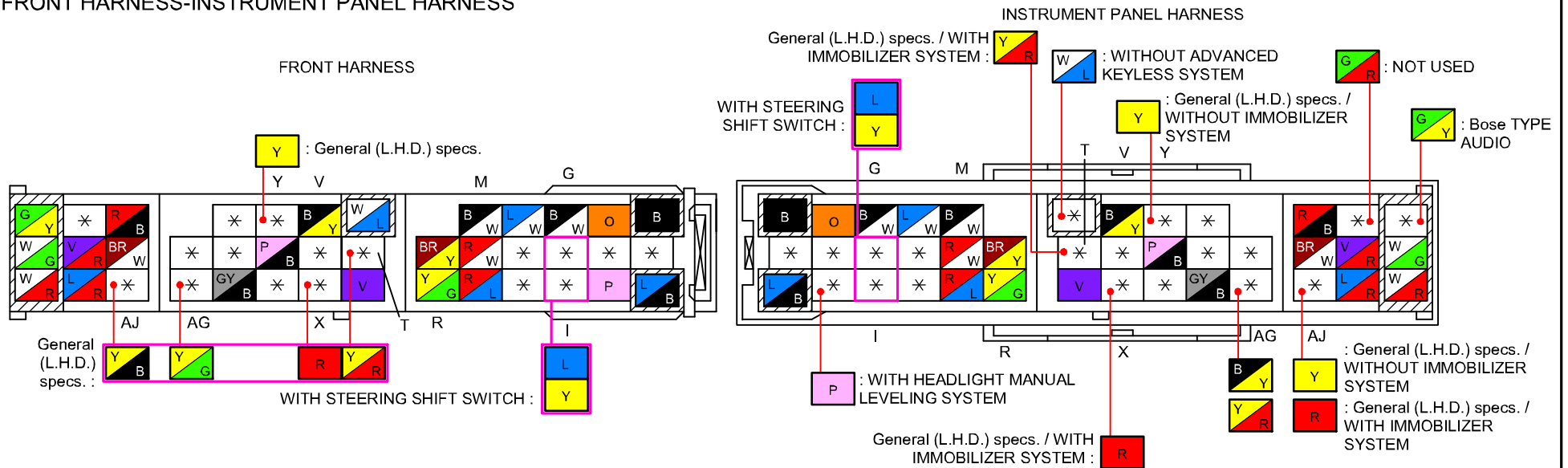

POWER SYSTEM (WITH ADVANCED KEYLESS SYSTEM)

0921-2a

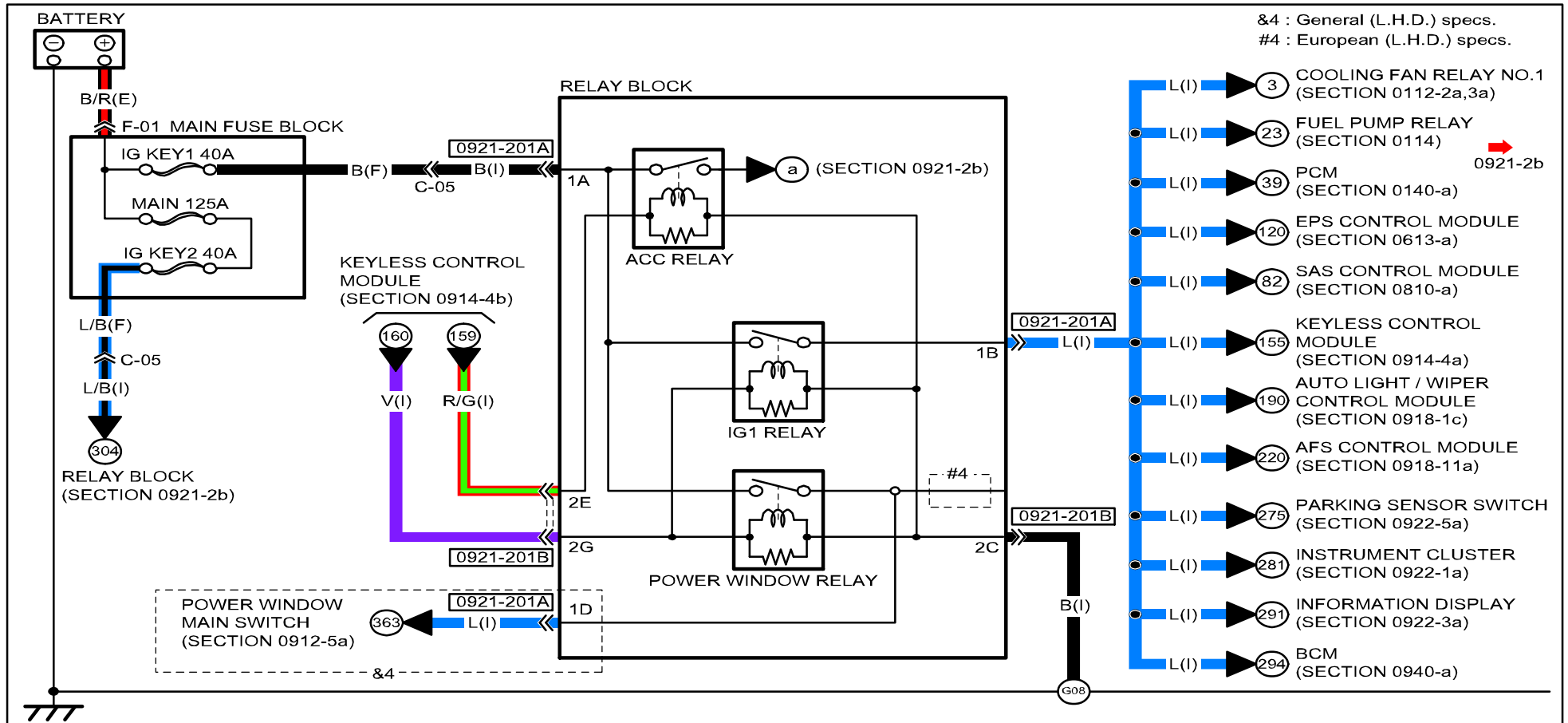

<p>0921-201A RELAY BLOCK</p> <p>1A 1C 1E B R L W D F 1B 1D 1F L : General (L.H.D.) specs.</p> <p>NOTE: SEEN FROM TERMINAL SIDE</p>	<p>0921-201B RELAY BLOCK</p> <p>2A 2C 2E 2G B W R G V 2B 2D 2F 2H * * *</p> <p>NOTE: SEEN FROM TERMINAL SIDE</p>			
---	---	--	--	--

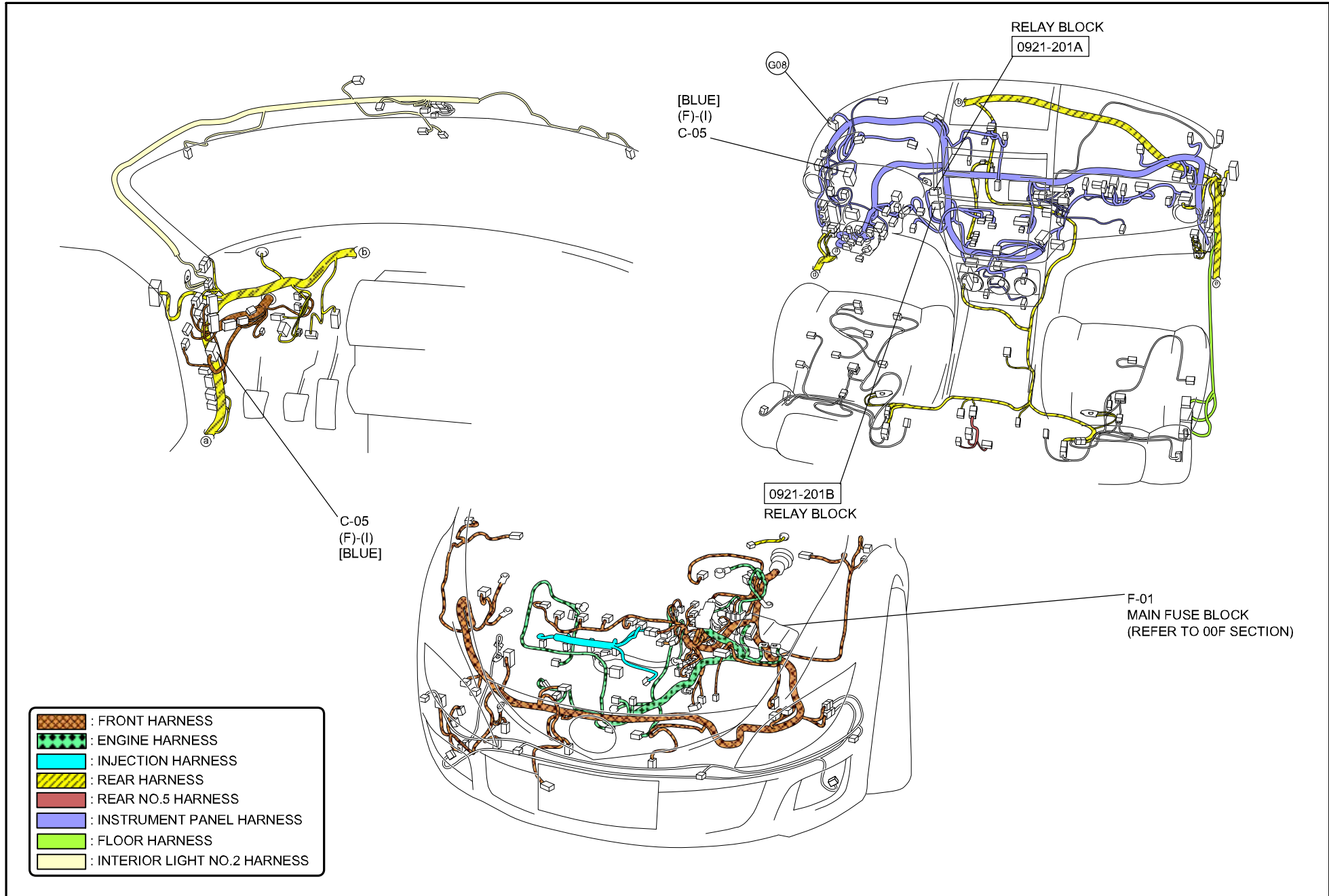

C-05

FRONT HARNESS-INSTRUMENT PANEL HARNESS

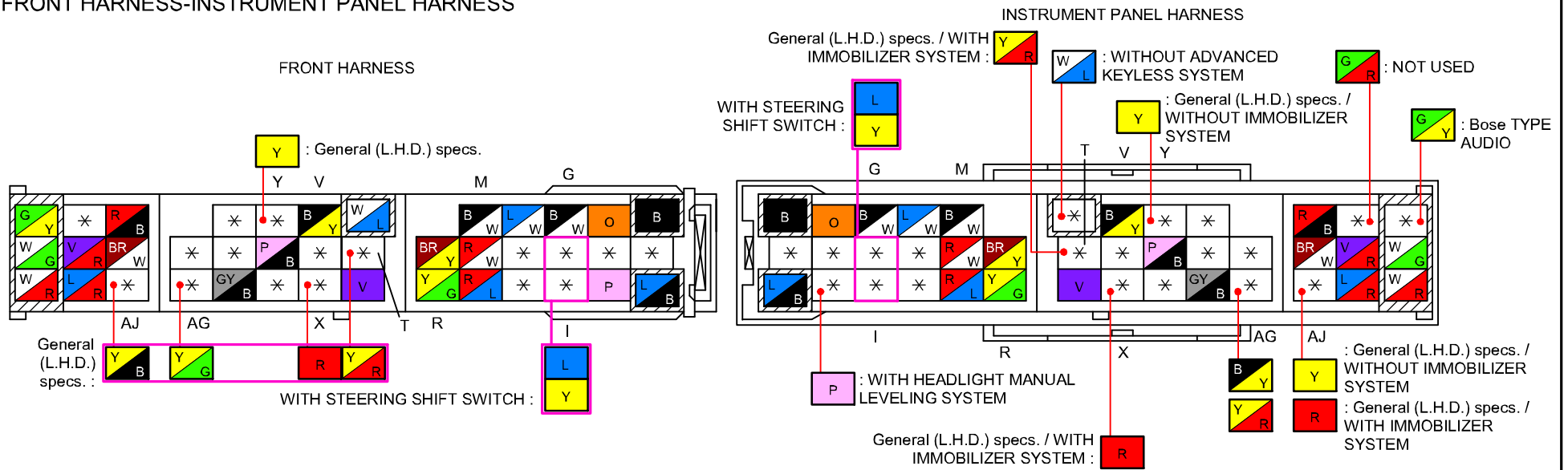

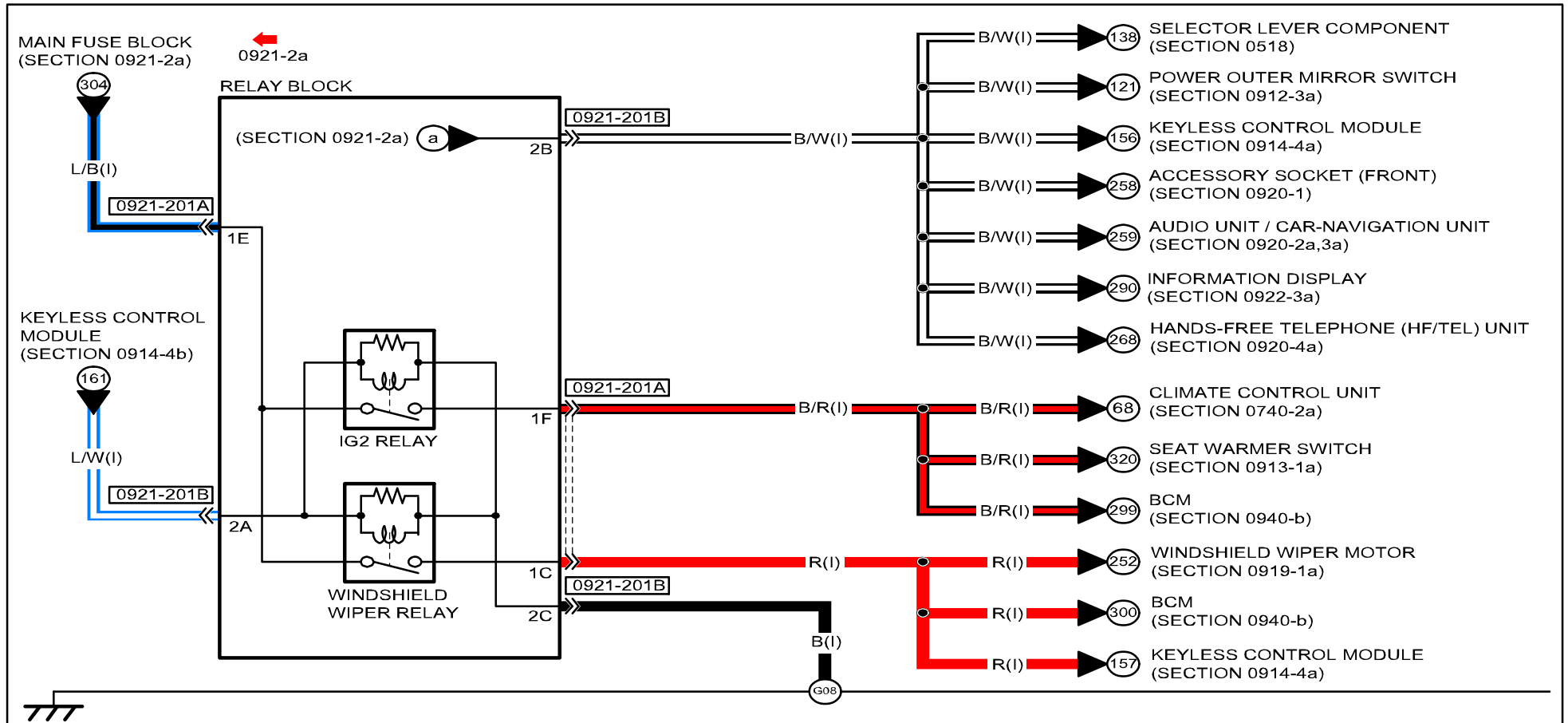

<p>0921-201A RELAY BLOCK</p> <p>1A 1C 1E B R L L W B R 1B 1D 1F L</p> <p>: General (L.H.D.) specs.</p> <p>NOTE:SEEN FROM TERMINAL SIDE</p>	<p>0921-201B RELAY BLOCK</p> <p>2A 2C 2E 2G B W B R G V B W * * * 2B 2D 2F 2H</p> <p>NOTE:SEEN FROM TERMINAL SIDE</p>			
--	---	--	--	--

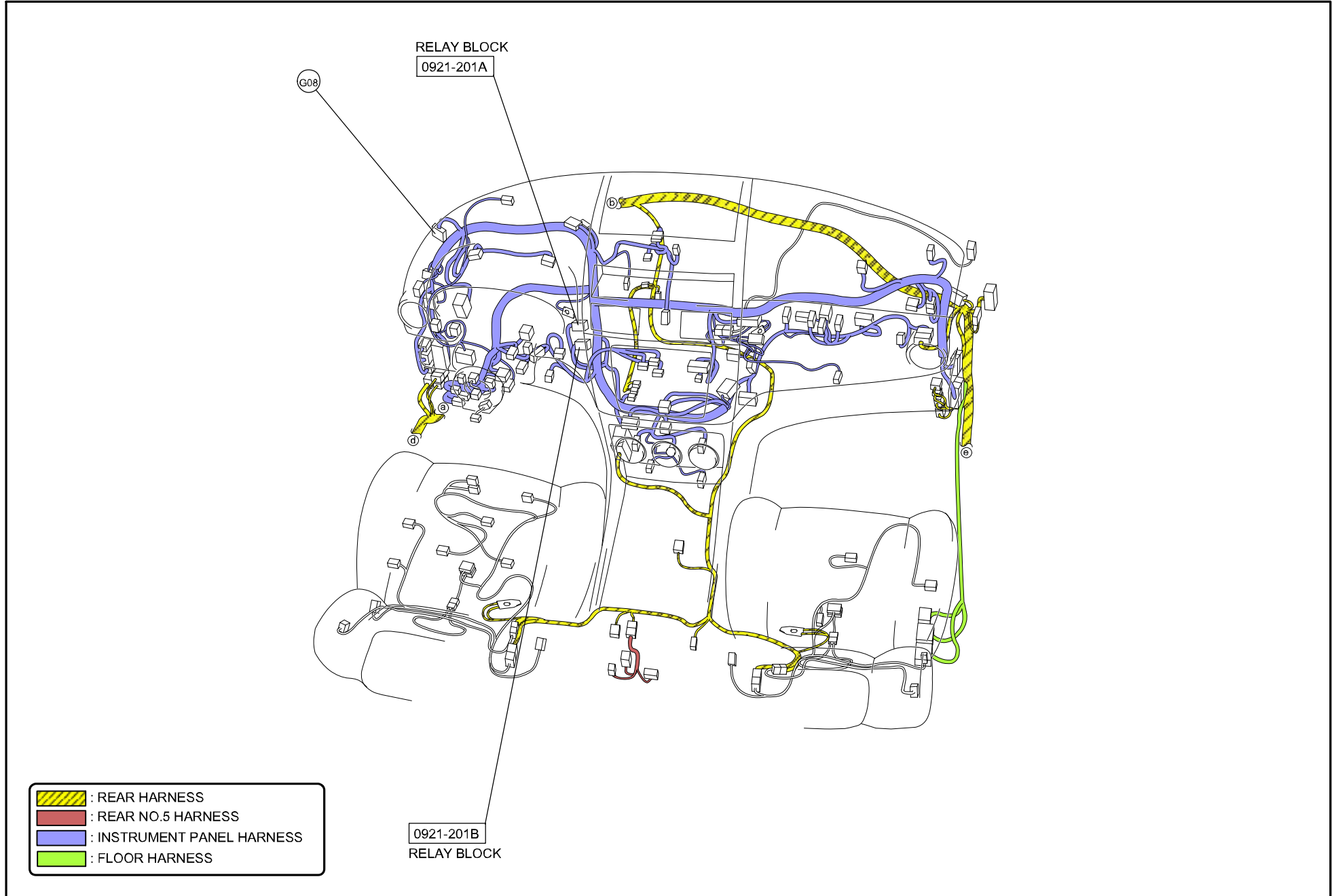

INSTRUMENT CLUSTER

0922-1a

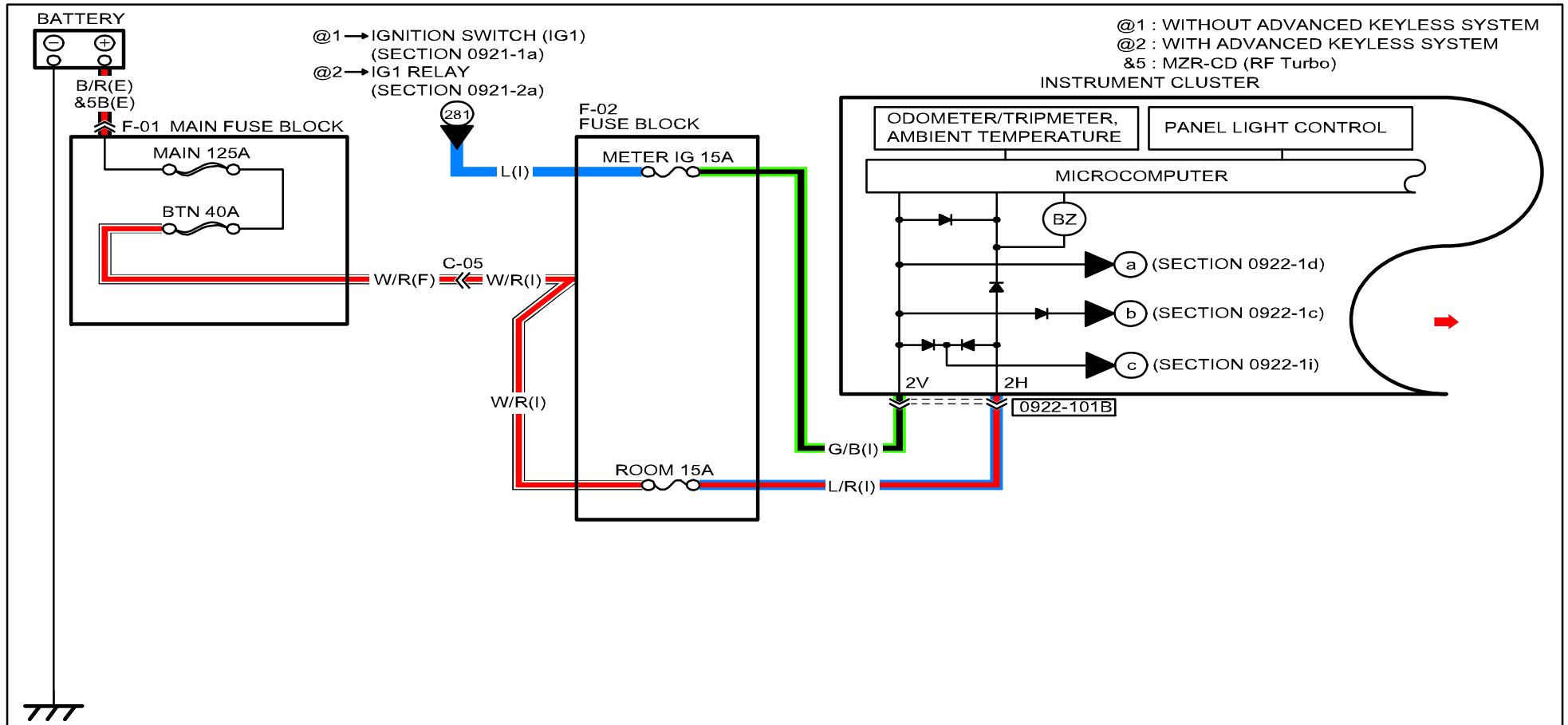

0922-101B
INSTRUMENT CLUSTER

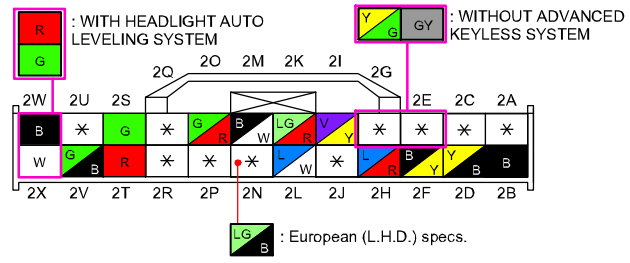

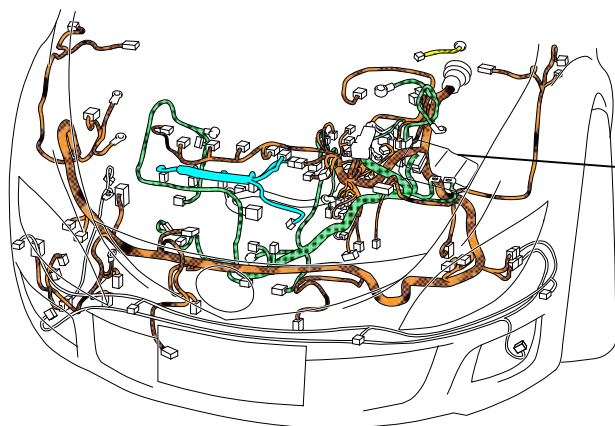

F-01
MAIN FUSE BLOCK
(REFER TO 00F SECTION)

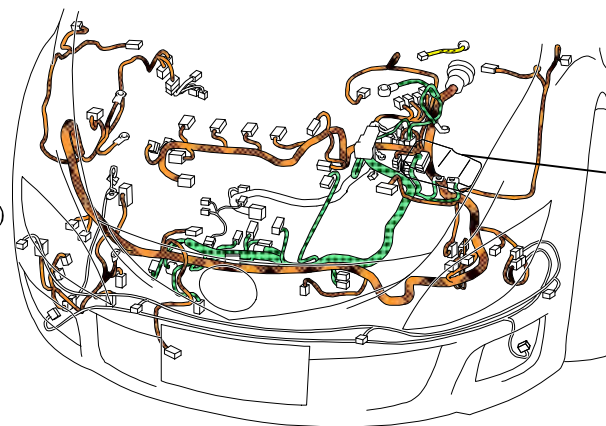

F-01
MAIN FUSE BLOCK
(REFER TO 00F SECTION)

[EXCEPT MZR-CD (RF Turbo)]

[MZR-CD (RF Turbo)]

INSTRUMENT CLUSTER
0922-101B

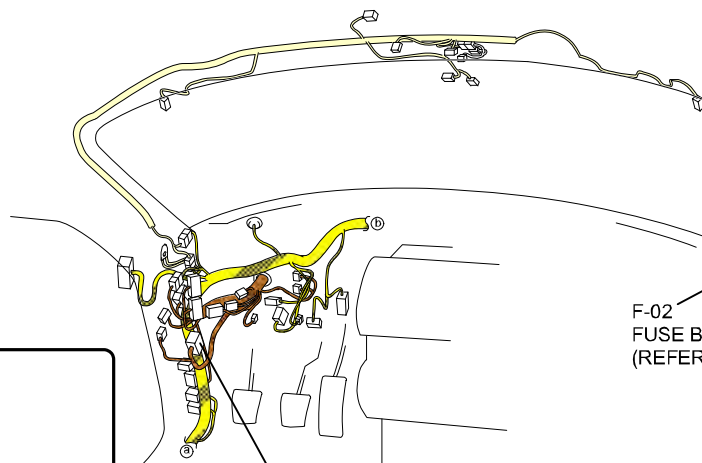







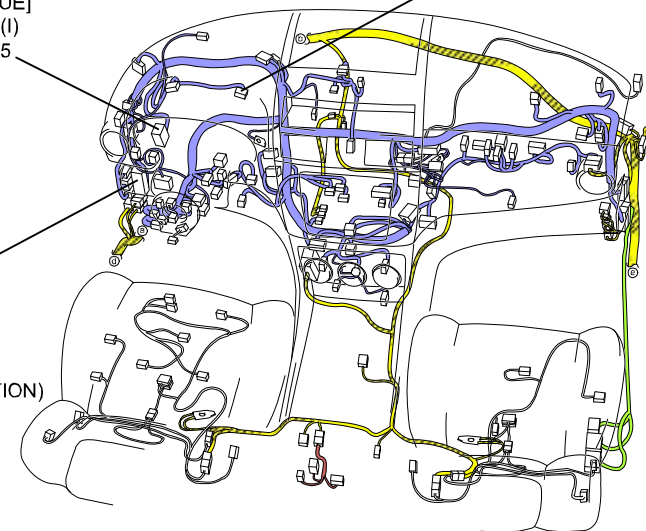

C-05
(F)-(I)
[BLUE]

[BLUE]
(F)-(I)
C-05

F-02
FUSE BLOCK
(REFER TO 00F SECTION)



-  : FRONT HARNESS
-  : ENGINE HARNESS
-  : INJECTION HARNESS
-  : REAR HARNESS
-  : REAR NO.5 HARNESS
-  : INSTRUMENT PANEL HARNESS
-  : FLOOR HARNESS
-  : INTERIOR LIGHT NO.2 HARNESS

INSTRUMENT CLUSTER

0922-1a

C-05

FRONT HARNESS-INSTRUMENT PANEL HARNESS

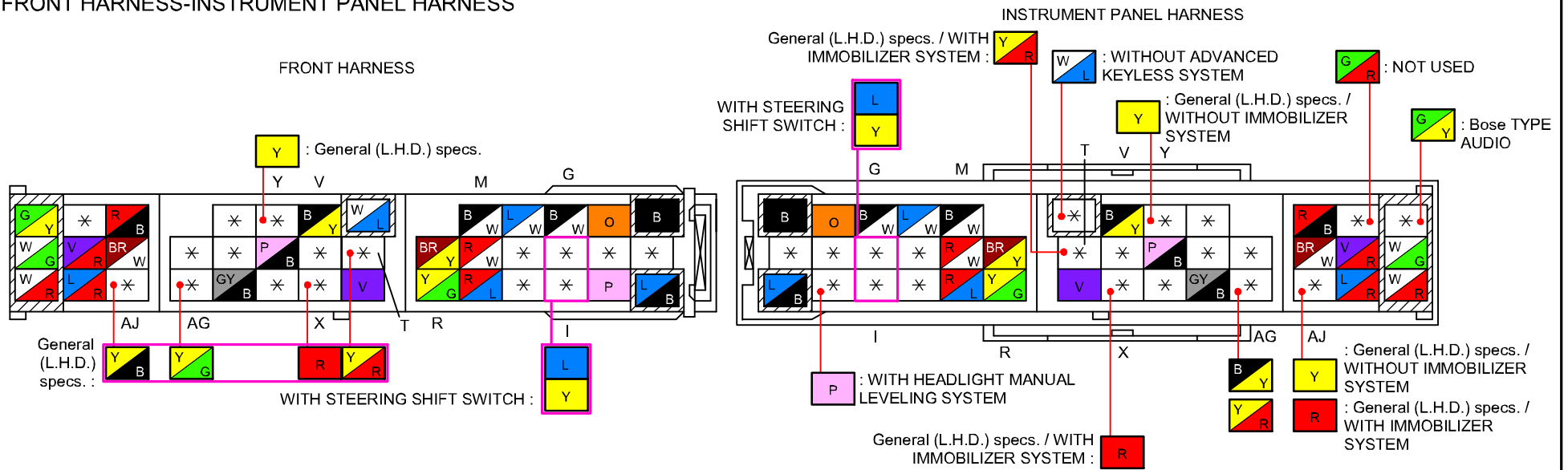

@1 : WITHOUT ADVANCED KEYLESS SYSTEM
 @5 : WITH HEADLIGHT AUTO LEVELING SYSTEM

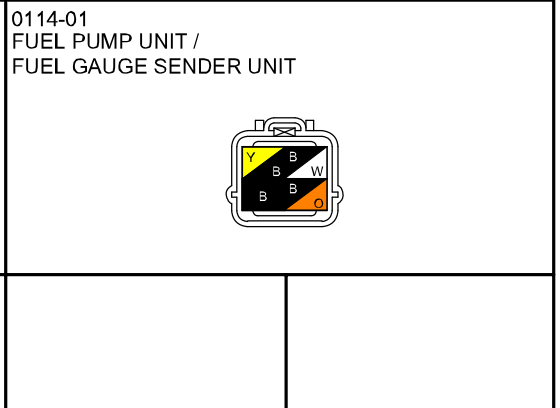
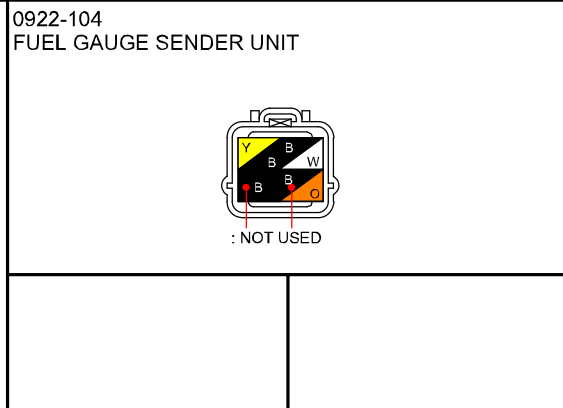
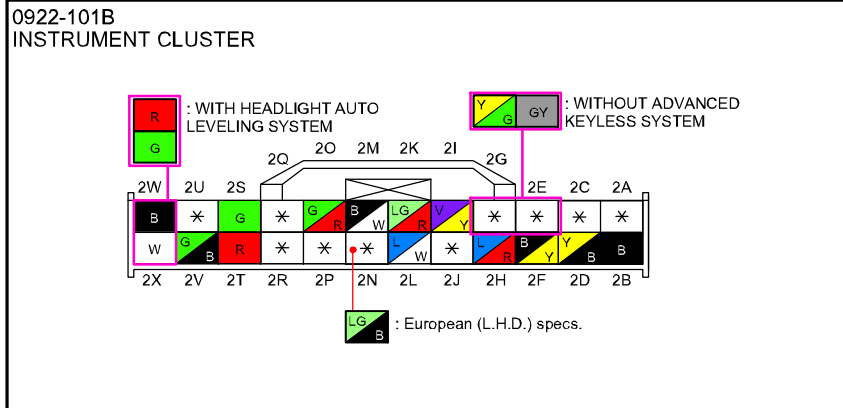
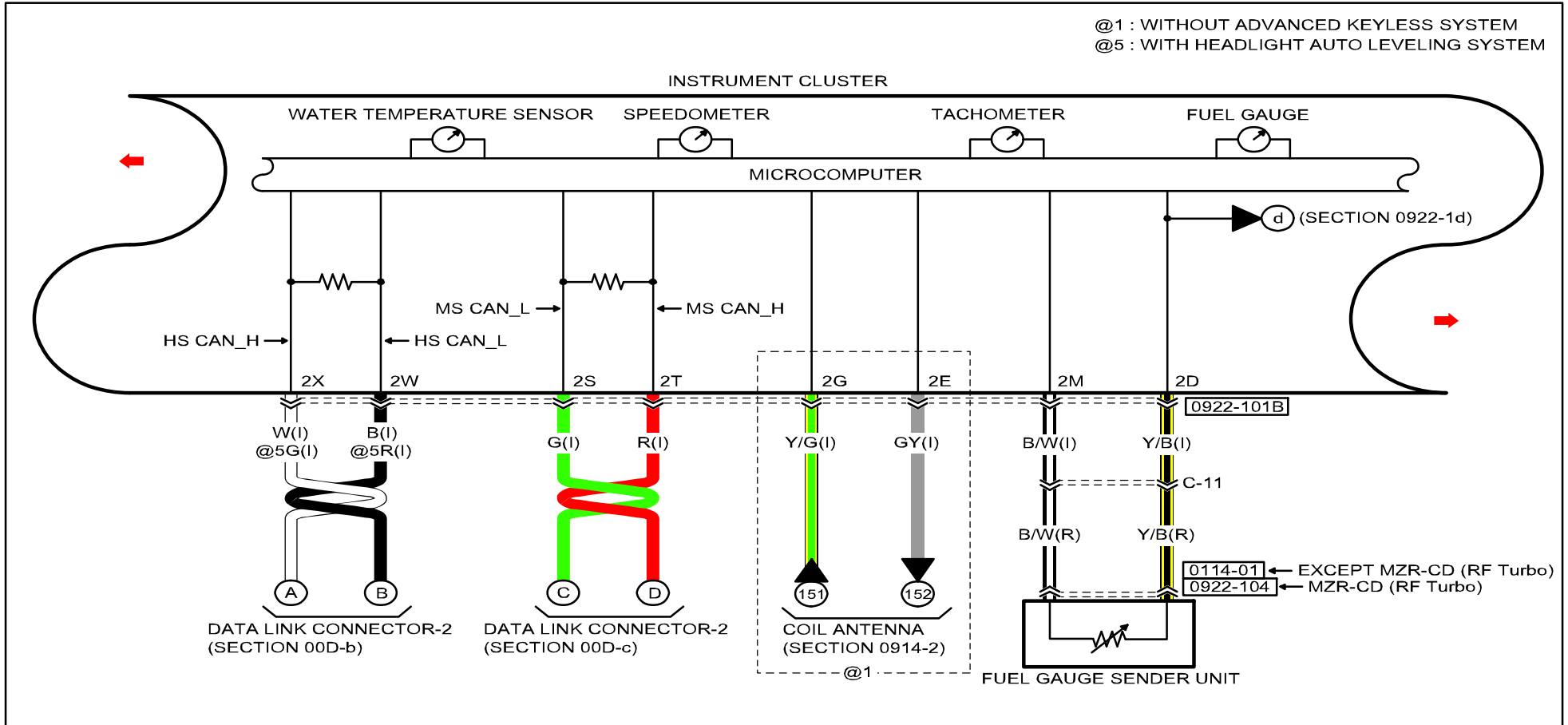

INSTRUMENT CLUSTER

0922-1b

- : INSTRUMENT PANEL HARNESS
- : REAR HARNESS
- : REAR NO.2 HARNESS
- : REAR NO.3 HARNESS
- : REAR NO.4 HARNESS
- : REAR NO.5 HARNESS
- : DOOR HARNESS
- : INTERIOR LIGHT HARNESS
- : FLOOR HARNESS

INSTRUMENT CLUSTER

0922-101B

C-11
(l)-(r)

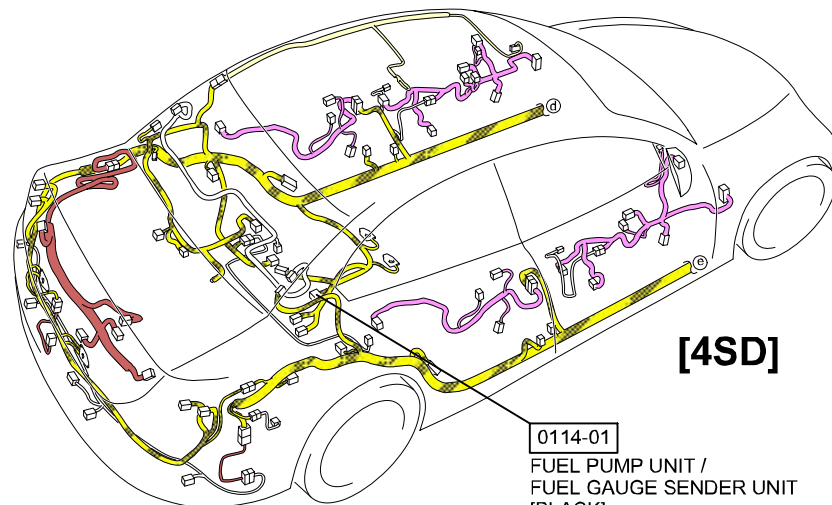
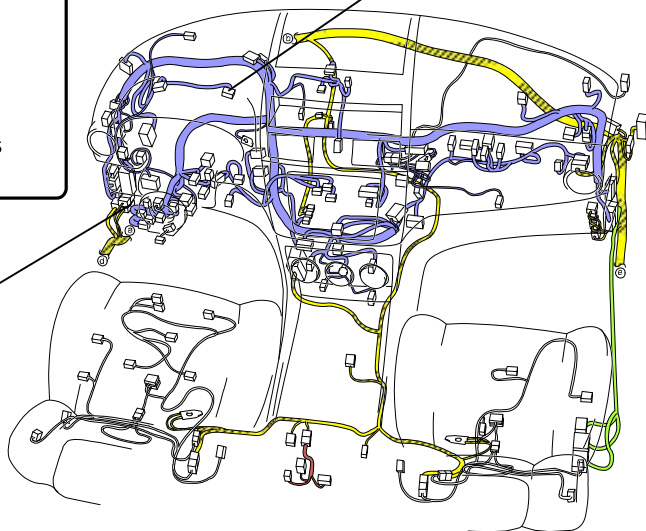

[4SD]

0114-01

FUEL PUMP UNIT /
FUEL GAUGE SENDER UNIT
[BLACK]

0922-104

FUEL GAUGE SENDER UNIT
[BLACK]

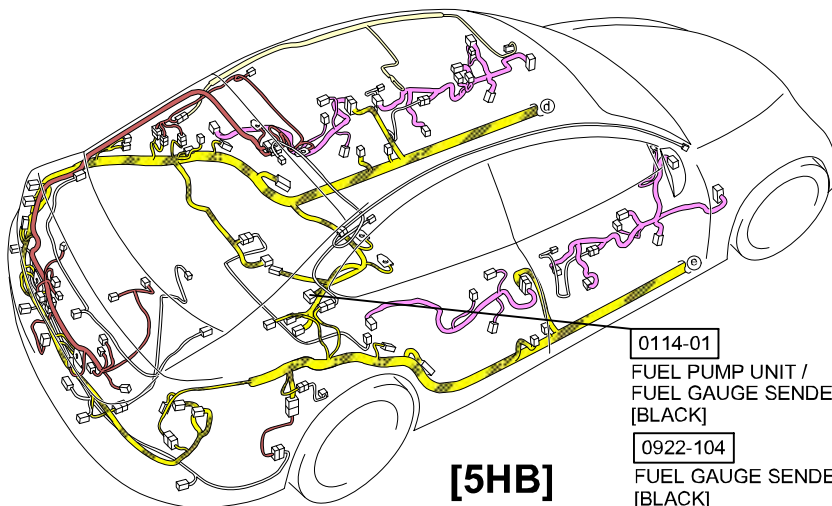

[5HB]

0114-01

FUEL PUMP UNIT /
FUEL GAUGE SENDER UNIT
[BLACK]

0922-104

FUEL GAUGE SENDER UNIT
[BLACK]

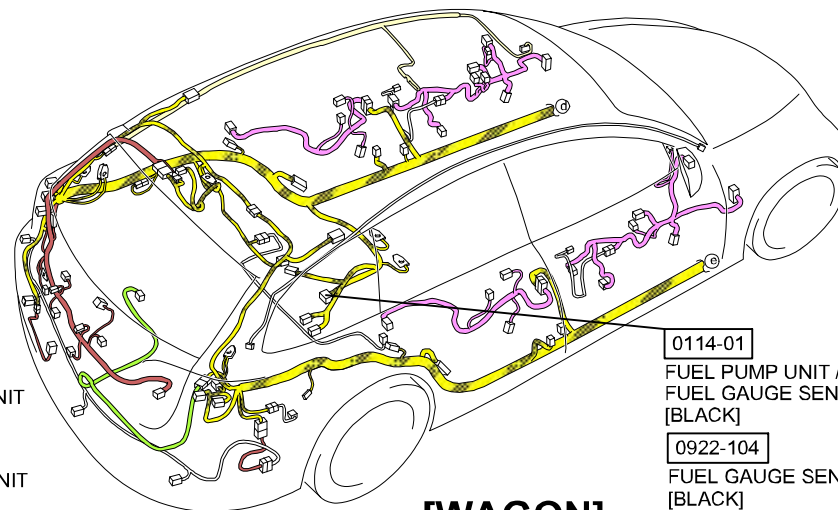

[WAGON]

0114-01

FUEL PUMP UNIT /
FUEL GAUGE SENDER UNIT
[BLACK]

0922-104

FUEL GAUGE SENDER UNIT
[BLACK]

C-11



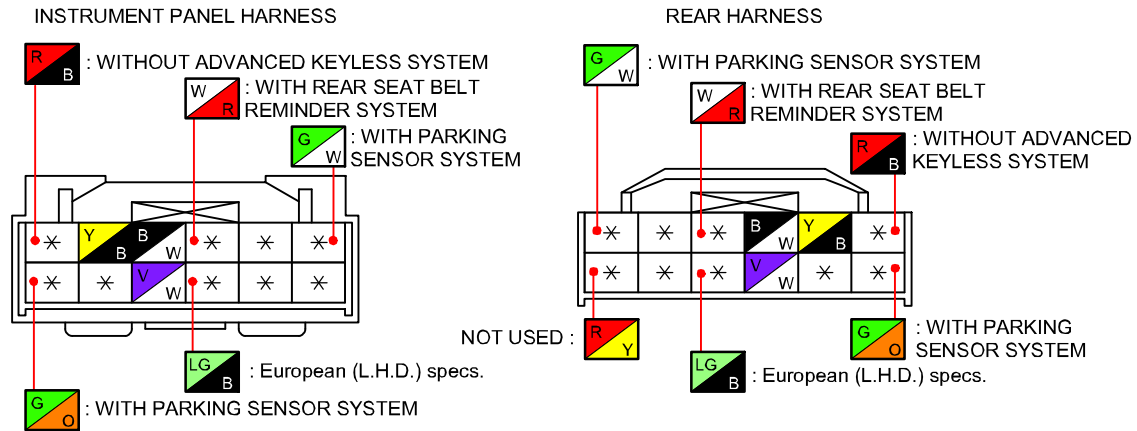

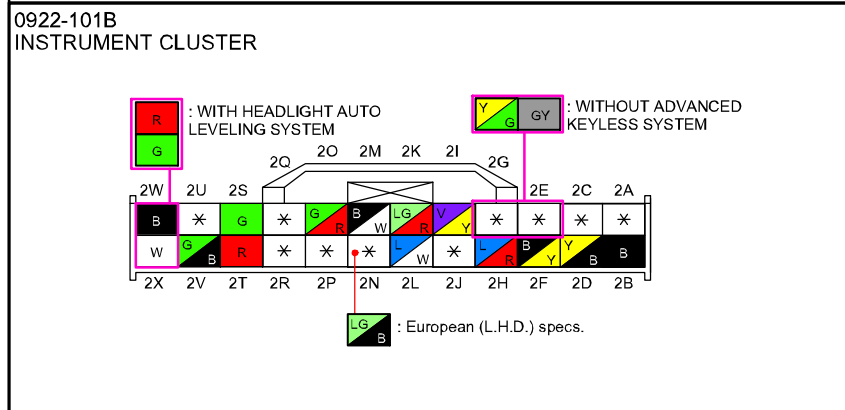
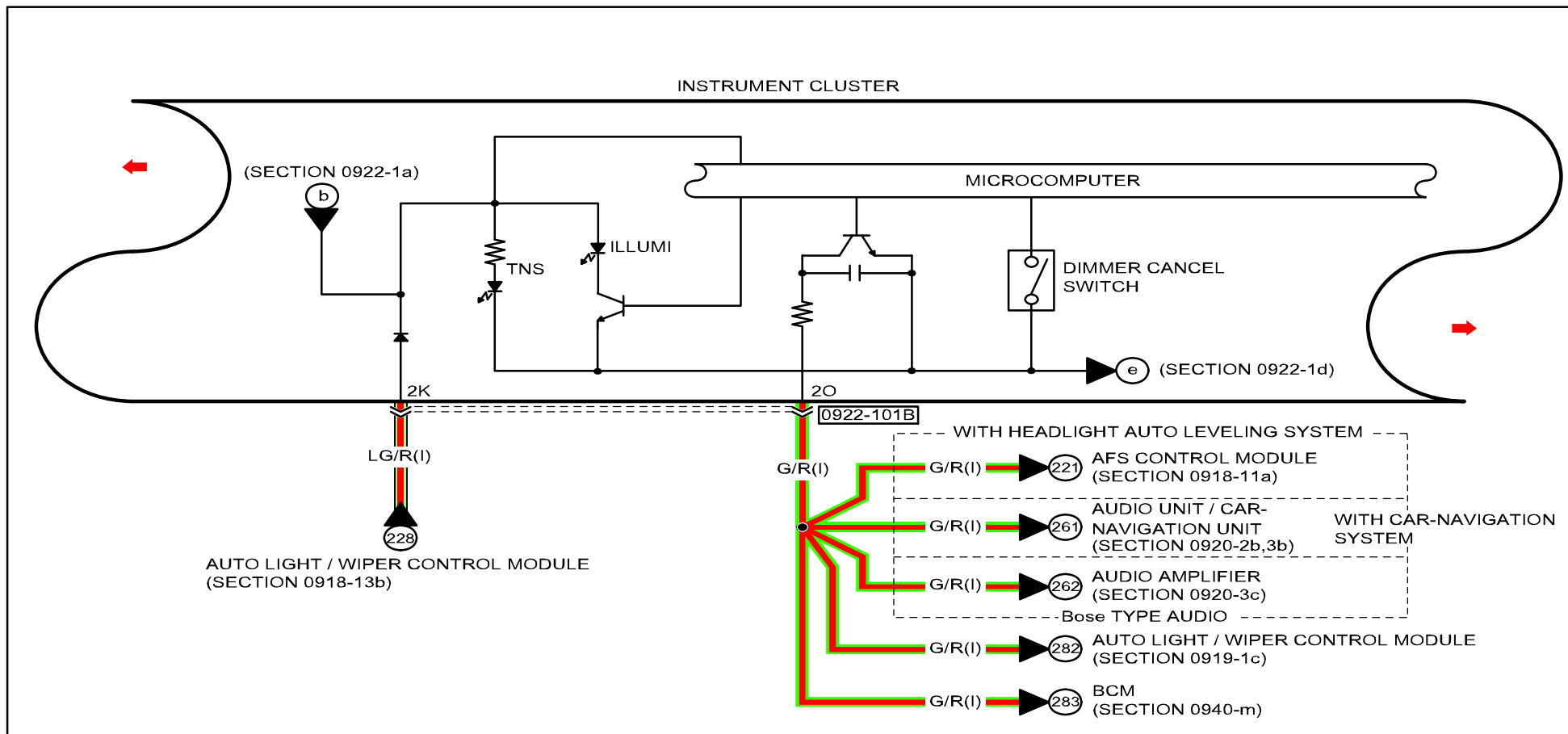
INSTRUMENT PANEL HARNESS-REAR HARNESS



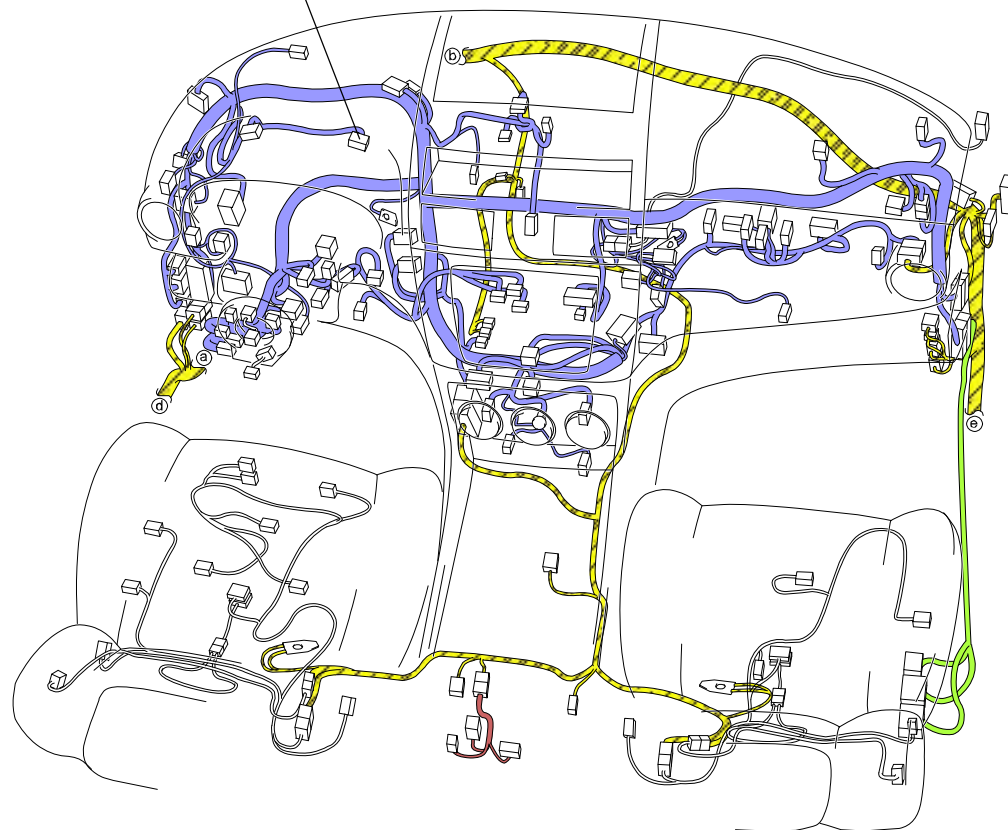





INSTRUMENT CLUSTER
0922-101B

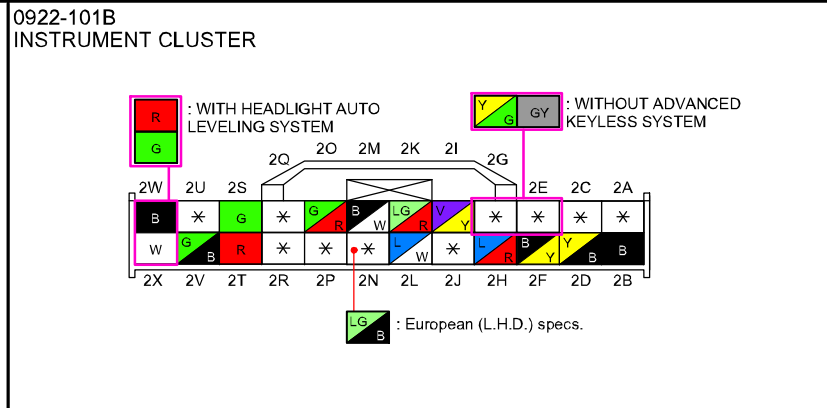
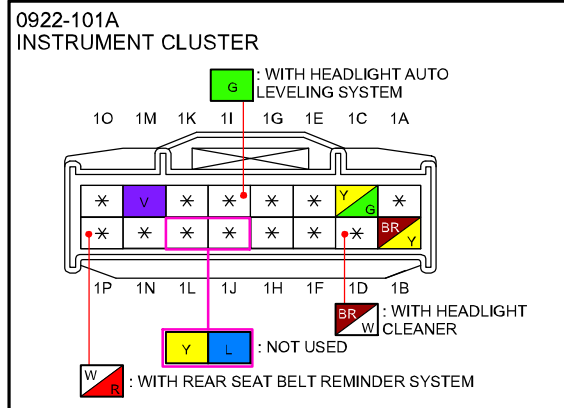
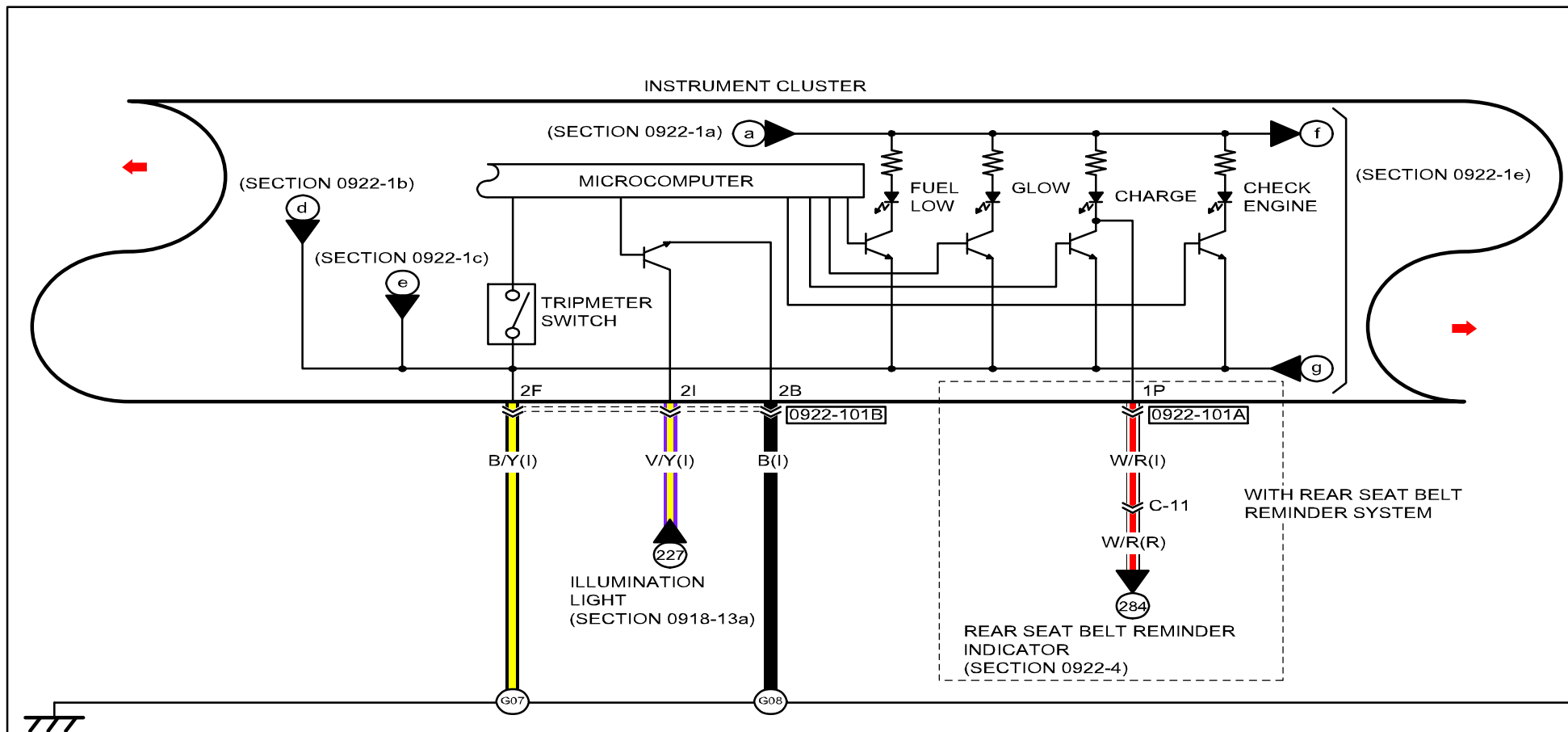

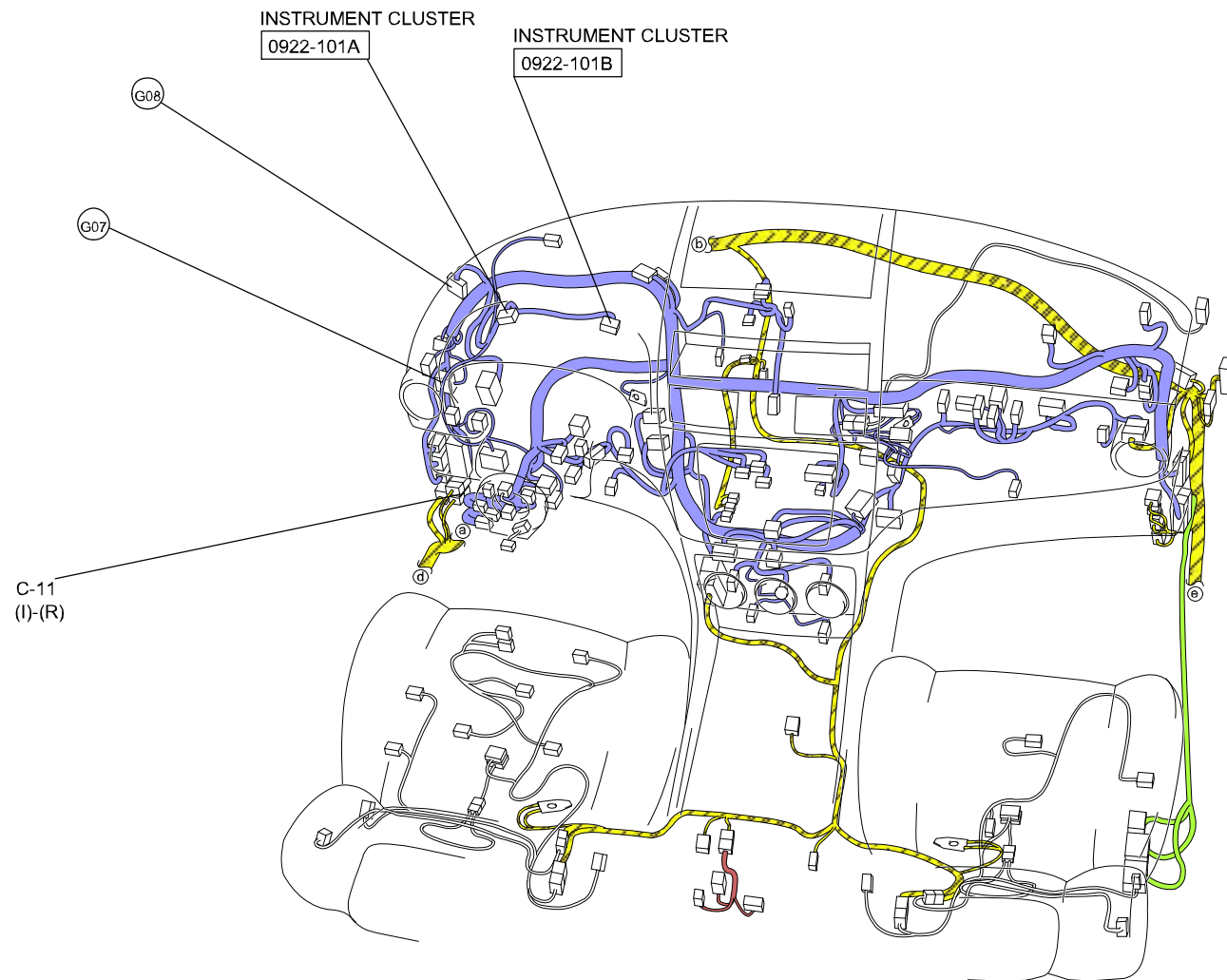
-  : REAR HARNESS
-  : REAR NO.5 HARNESS
-  : INSTRUMENT PANEL HARNESS
-  : FLOOR HARNESS





-  : REAR HARNESS
-  : REAR NO.5 HARNESS
-  : INSTRUMENT PANEL HARNESS
-  : FLOOR HARNESS

C-11

INSTRUMENT PANEL HARNESS-REAR HARNESS

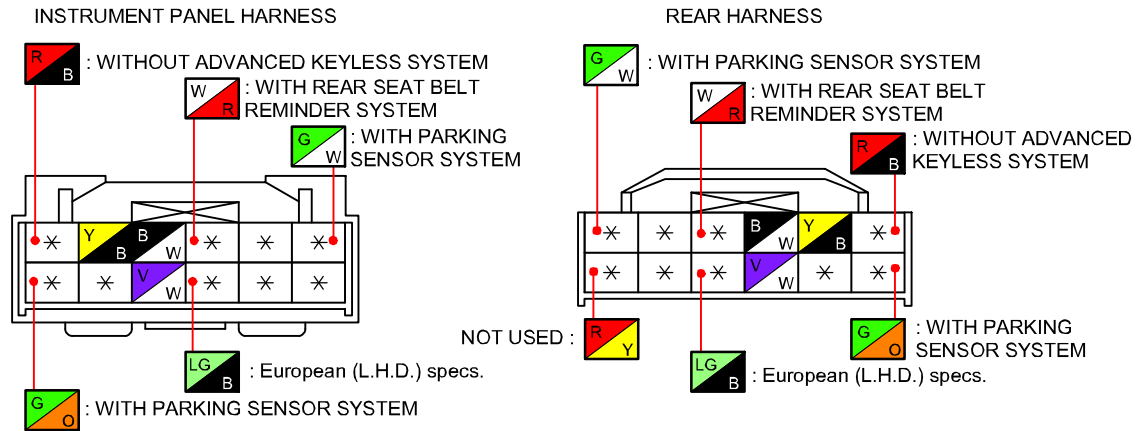

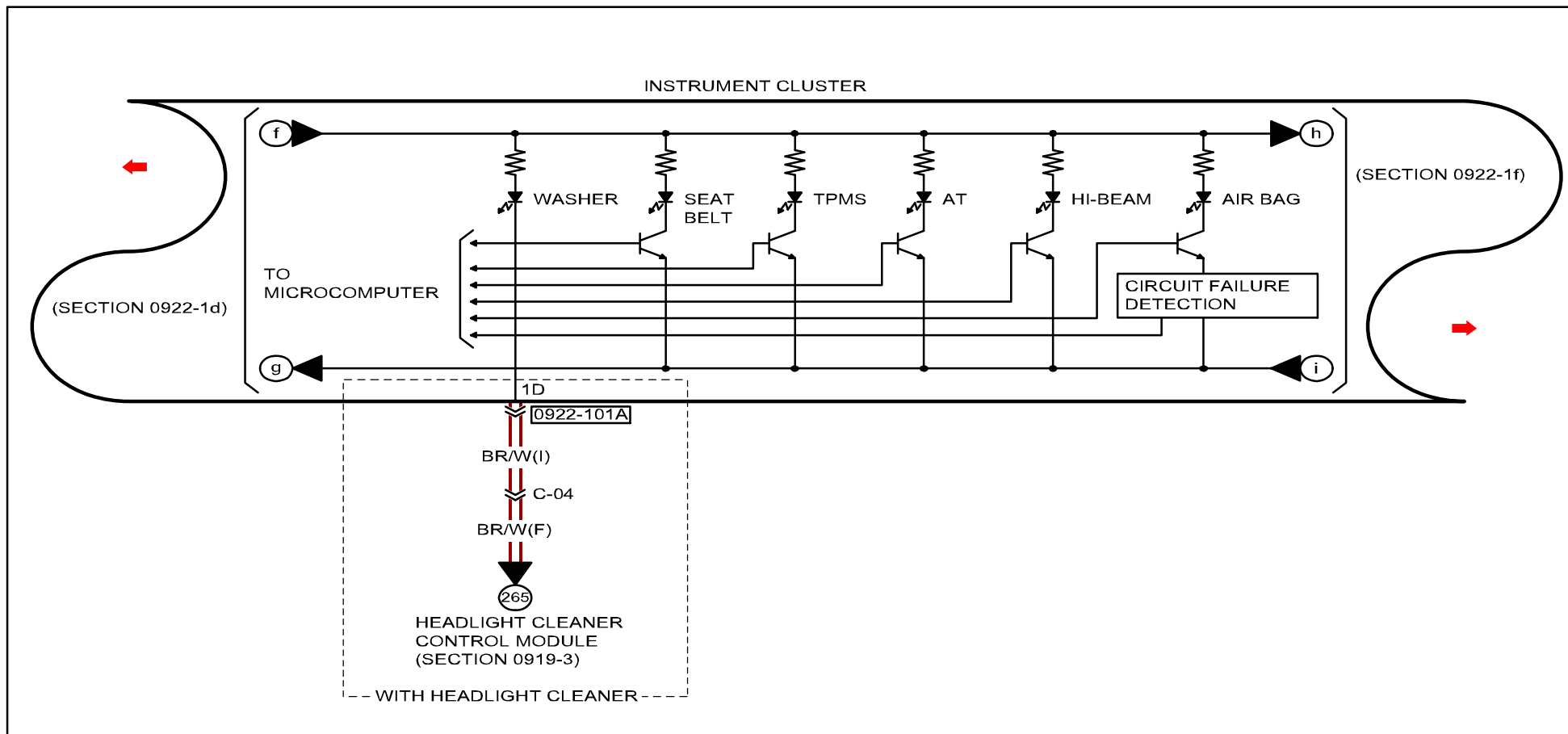

<p>0922-101A INSTRUMENT CLUSTER</p> <p>10 1M 1K 1I 1G 1E 1C 1A</p> <p>1P 1N 1L 1J 1H 1F 1D 1B</p> <p> G : WITH HEADLIGHT AUTO LEVELING SYSTEM Y L : NOT USED W R : WITH REAR SEAT BELT REMINDER SYSTEM BR W : WITH HEADLIGHT CLEANER </p>					
---	--	--	--	--	--

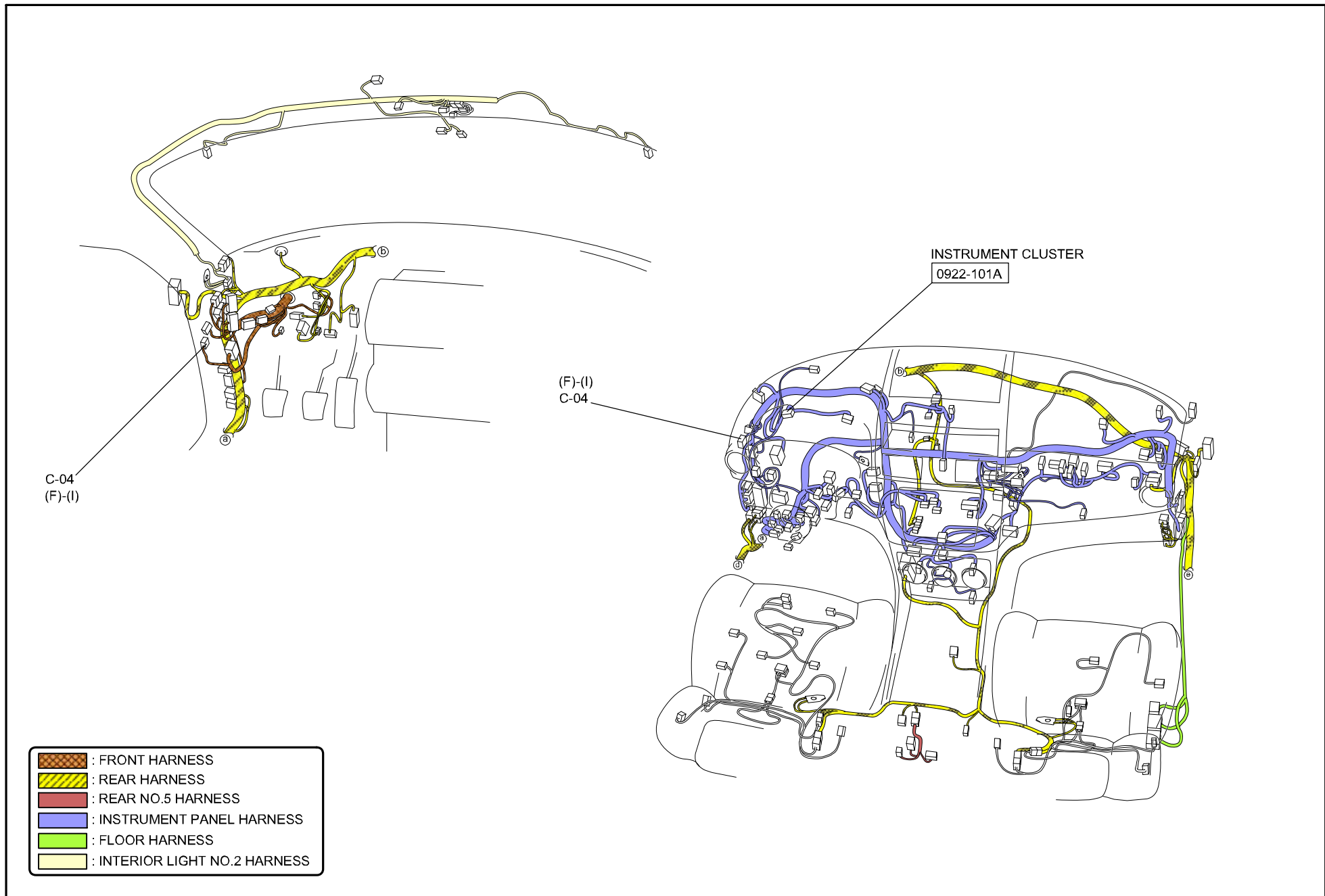

C-04

FRONT HARNESS-INSTRUMENT PANEL HARNESS

FRONT HARNESS

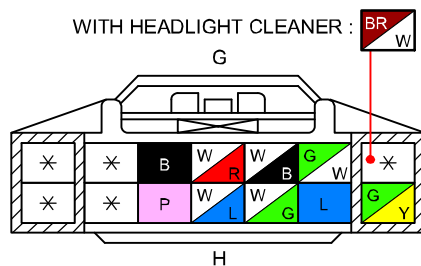

INSTRUMENT PANEL HARNESS

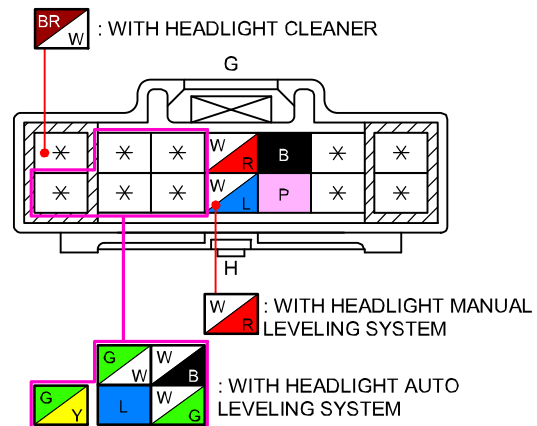

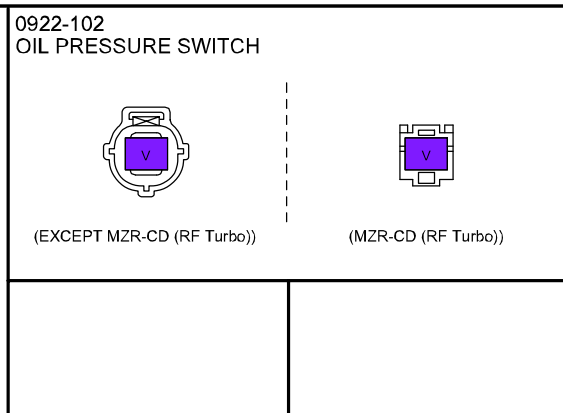
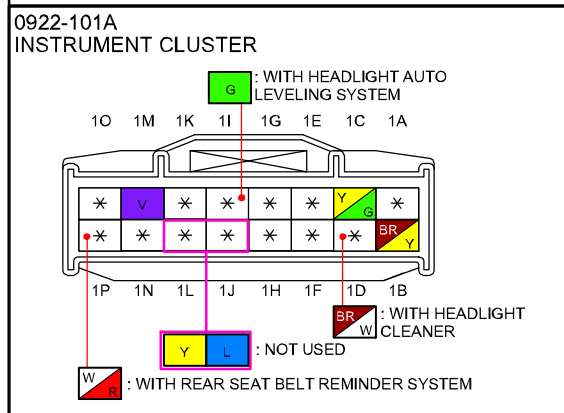
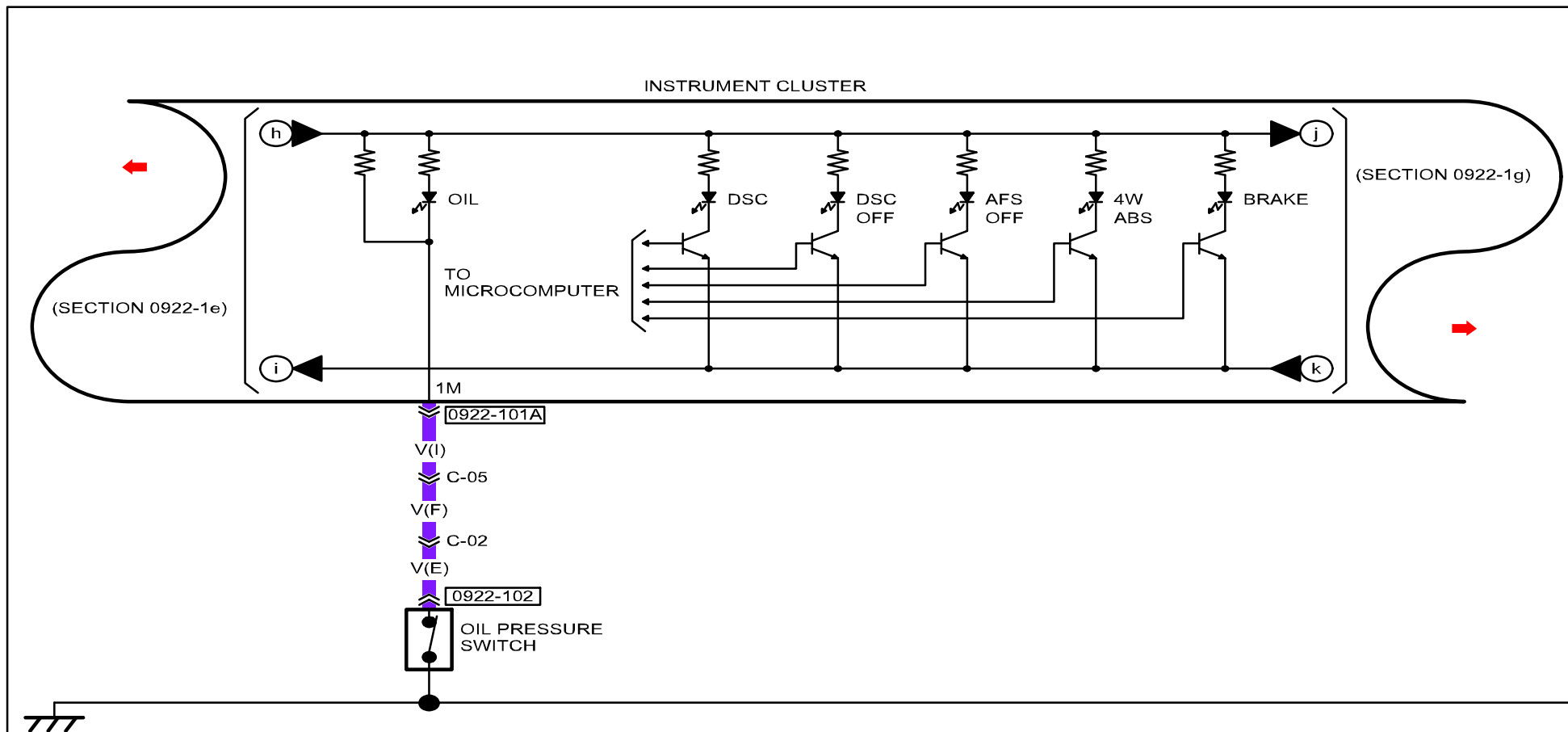

[EXCEPT MZR-CD (RF Turbo)]

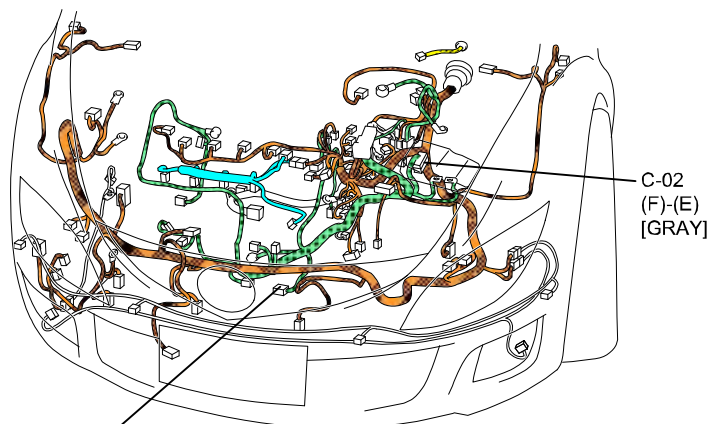

0922-102
OIL PRESSURE SWITCH
[BLACK]

[MZR-CD (RF Turbo)]

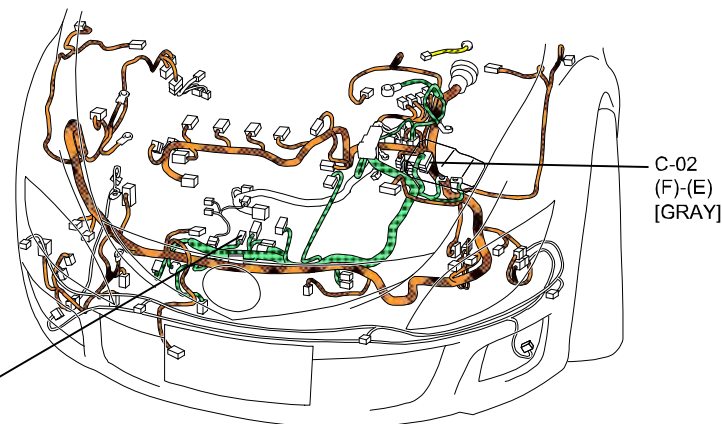

0922-102
OIL PRESSURE SWITCH
[BLACK]

INSTRUMENT CLUSTER
0922-101A

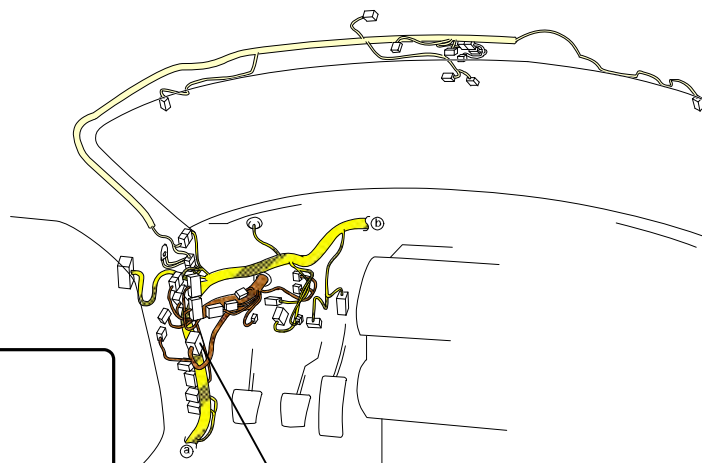

C-05
(F)-(I)
[BLUE]

[BLUE]
(F)-(I)
C-05

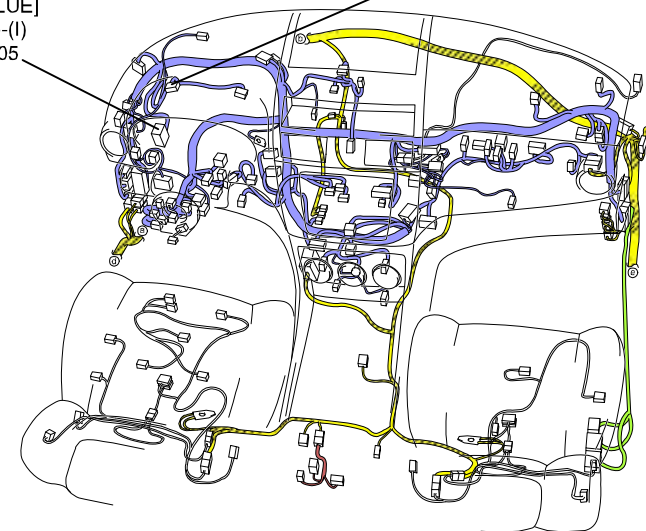

- : FRONT HARNESS
- : ENGINE HARNESS
- : INJECTION HARNESS
- : REAR HARNESS
- : REAR NO.5 HARNESS
- : INSTRUMENT PANEL HARNESS
- : FLOOR HARNESS
- : INTERIOR LIGHT NO.2 HARNESS

C-02
FRONT HARNESS-ENGINE HARNESS

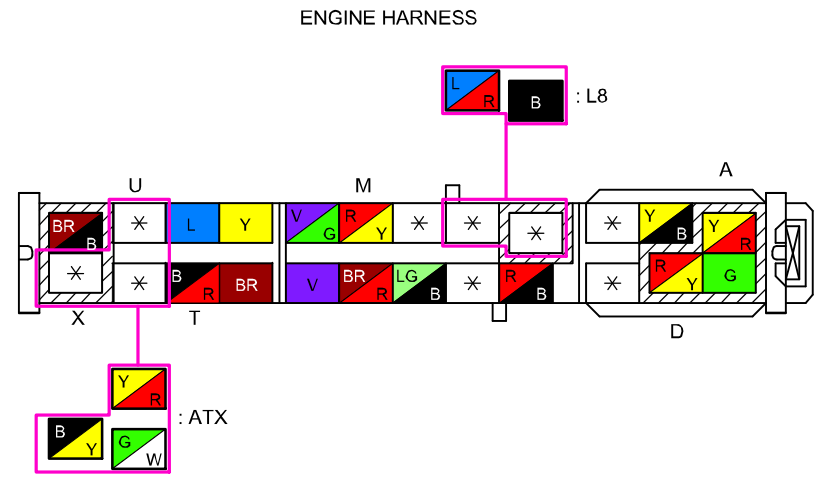
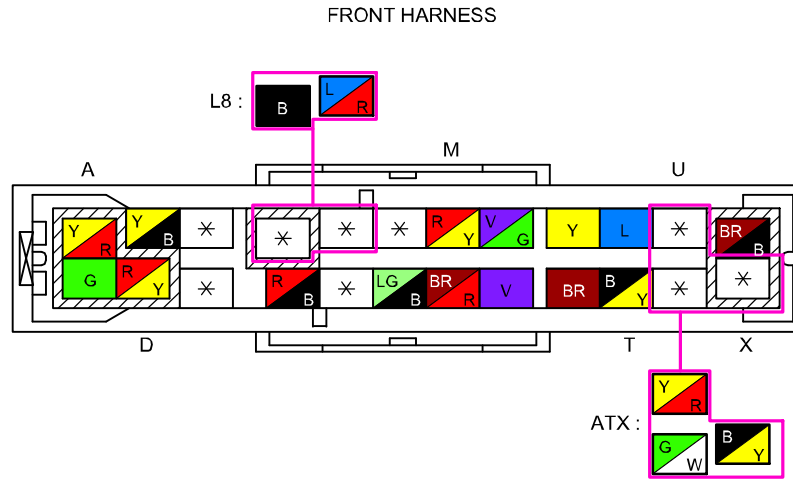

(EXCEPT MZR-CD (RF Turbo))

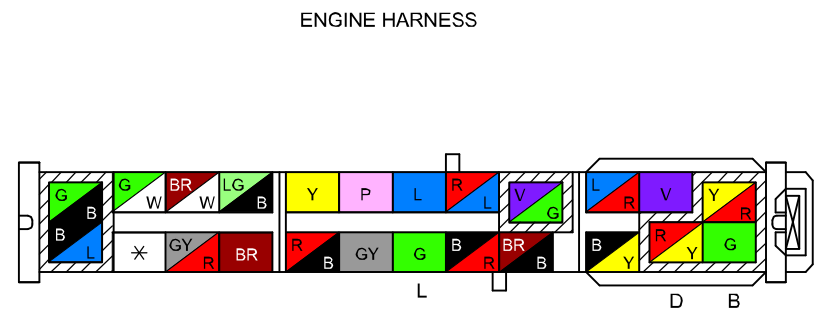
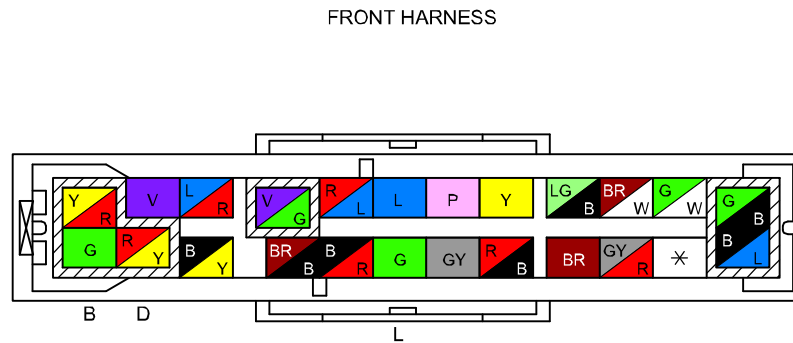

(MZR-CD (RF Turbo))

C-05



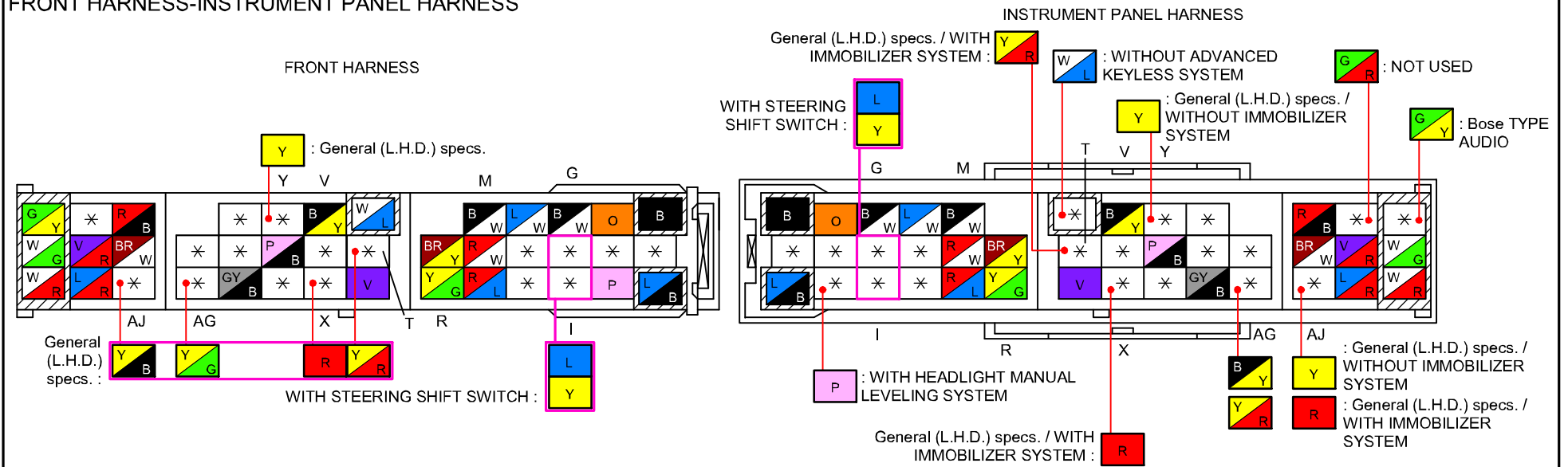

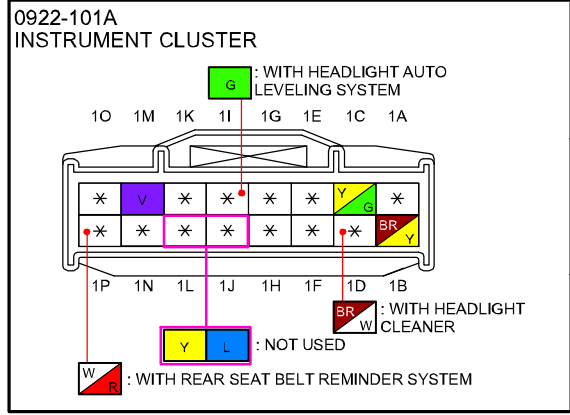
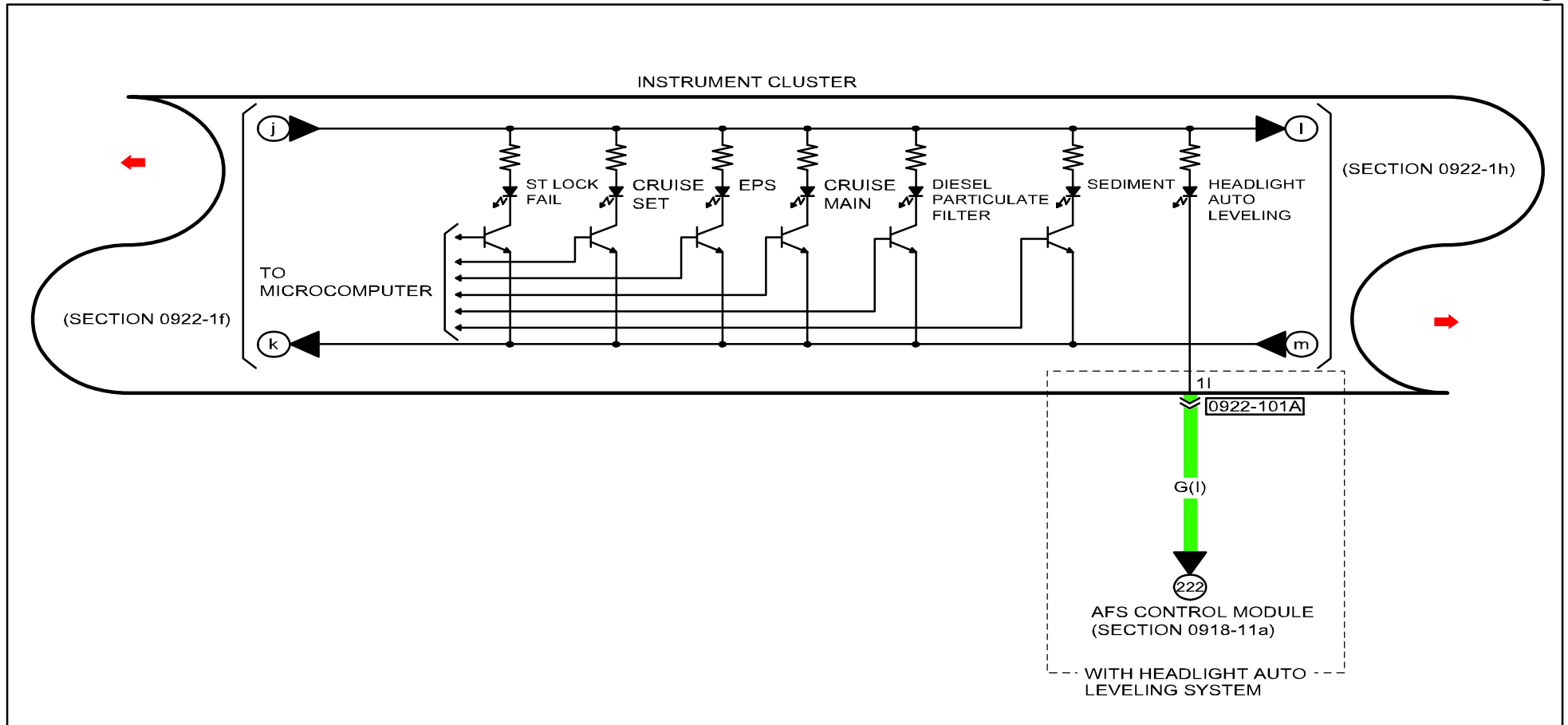
FRONT HARNESS-INSTRUMENT PANEL HARNESS



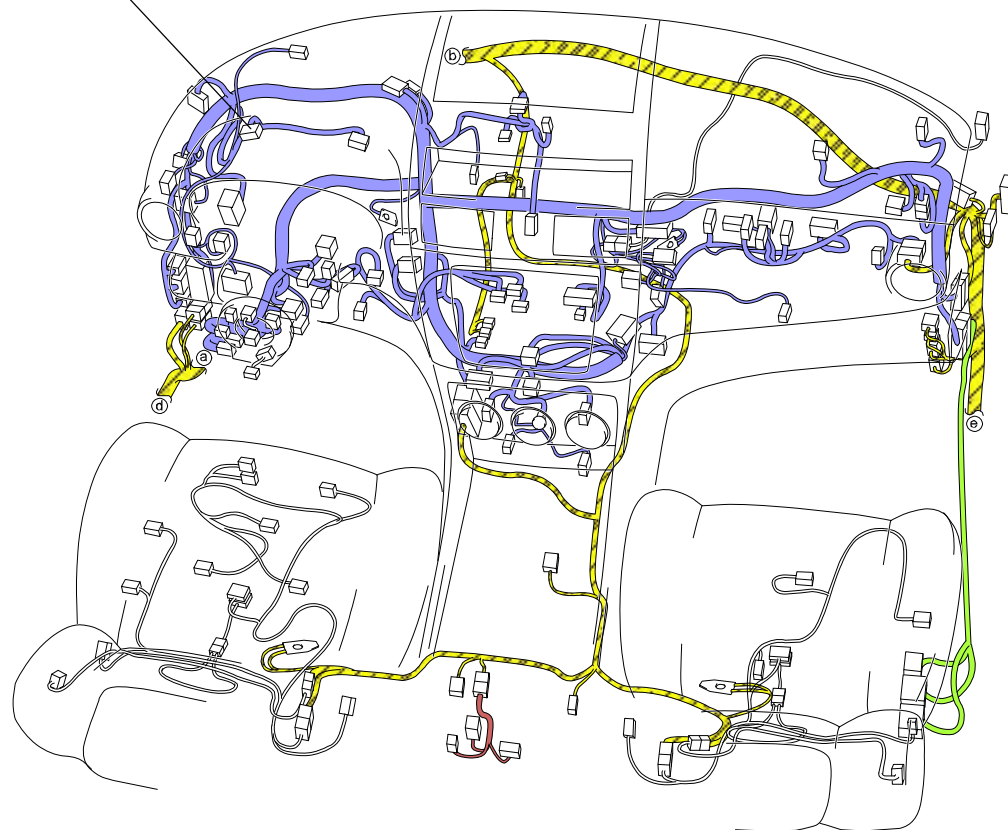

INSTRUMENT CLUSTER
0922-101A



-  : REAR HARNESS
-  : REAR NO.5 HARNESS
-  : INSTRUMENT PANEL HARNESS
-  : FLOOR HARNESS

#4 : European (L.H.D.) specs.

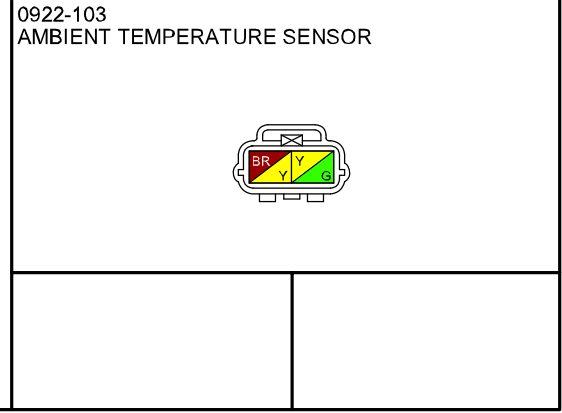
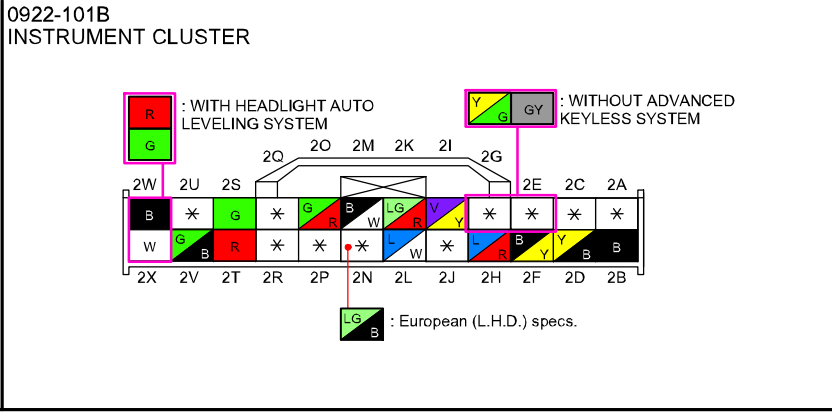
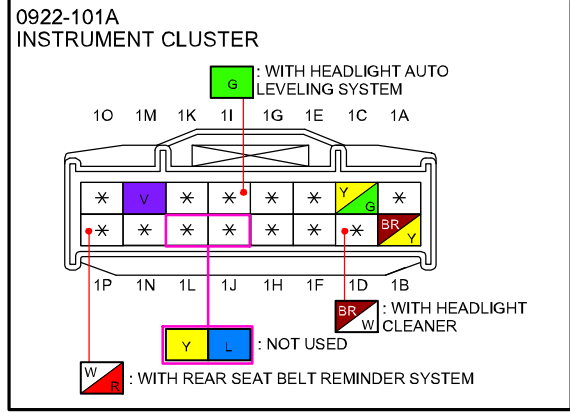
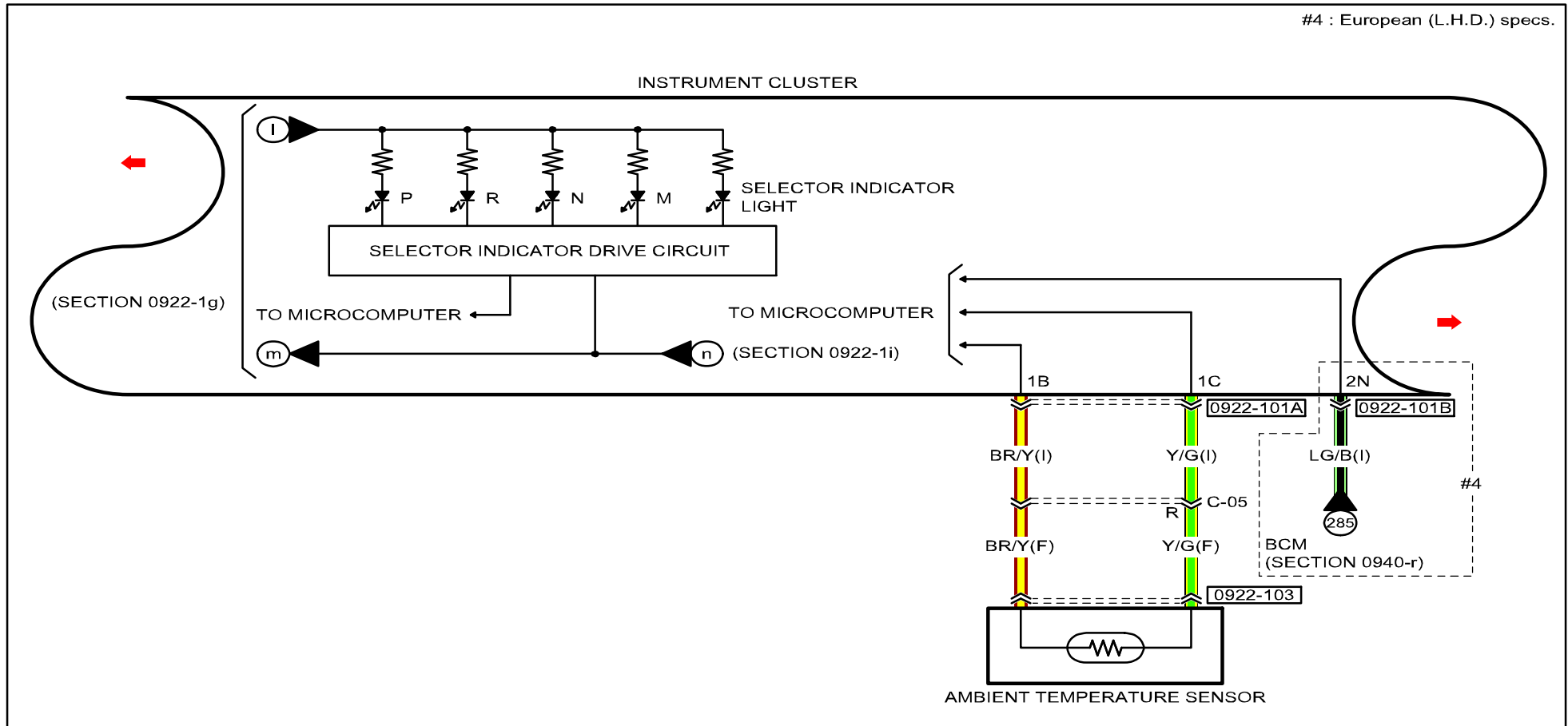

[EXCEPT MZR-CD (RF Turbo)]

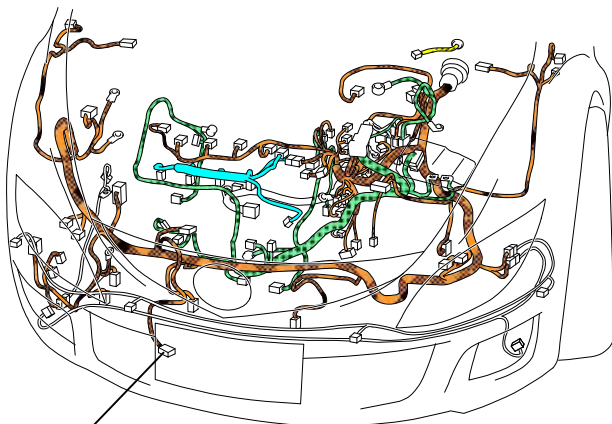

0922-103
 AMBIENT TEMPERATURE SENSOR
 [GRAY]

[MZR-CD (RF Turbo)]

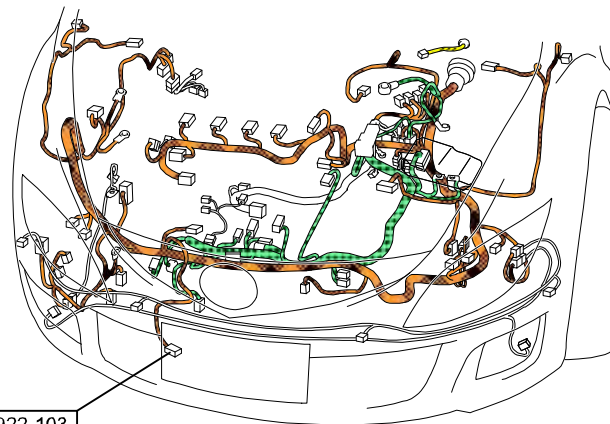

0922-103
 AMBIENT TEMPERATURE SENSOR
 [GRAY]

INSTRUMENT CLUSTER

0922-101A

INSTRUMENT CLUSTER





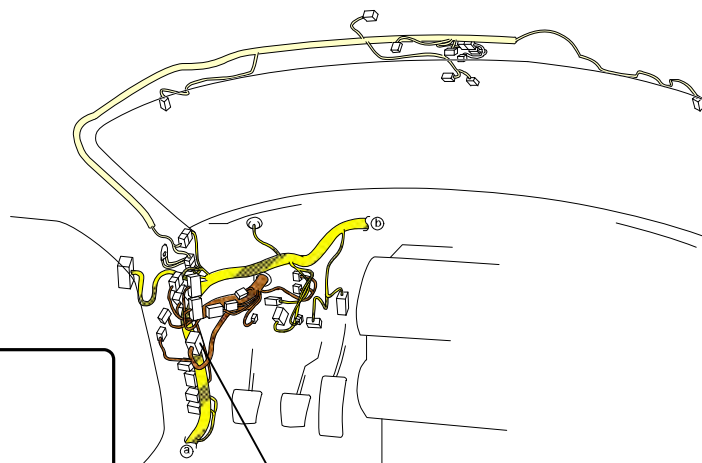

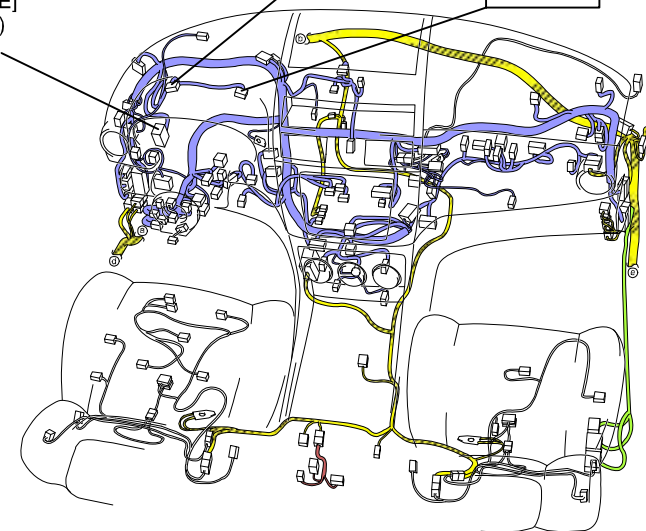

0922-101B

[BLUE]
 (F)-(I)
 C-05



C-05
 (F)-(I)
 [BLUE]



-  : FRONT HARNESS
-  : ENGINE HARNESS
-  : INJECTION HARNESS
-  : REAR HARNESS
-  : REAR NO.5 HARNESS
-  : INSTRUMENT PANEL HARNESS
-  : FLOOR HARNESS
-  : INTERIOR LIGHT NO.2 HARNESS

INSTRUMENT CLUSTER

0922-1h



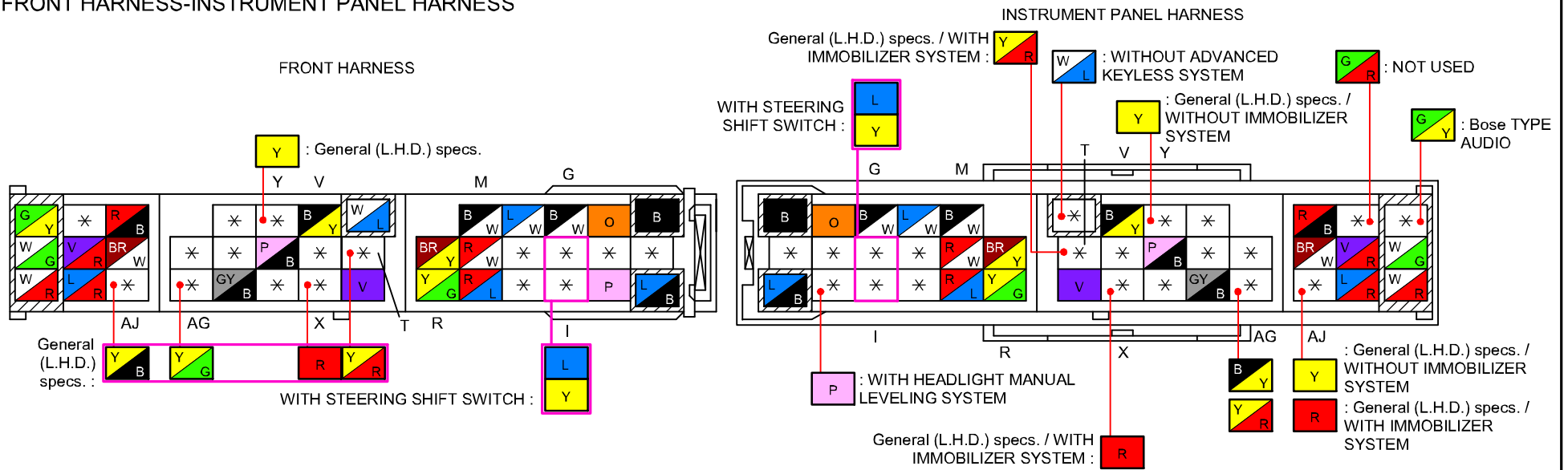

C-05

FRONT HARNESS-INSTRUMENT PANEL HARNESS

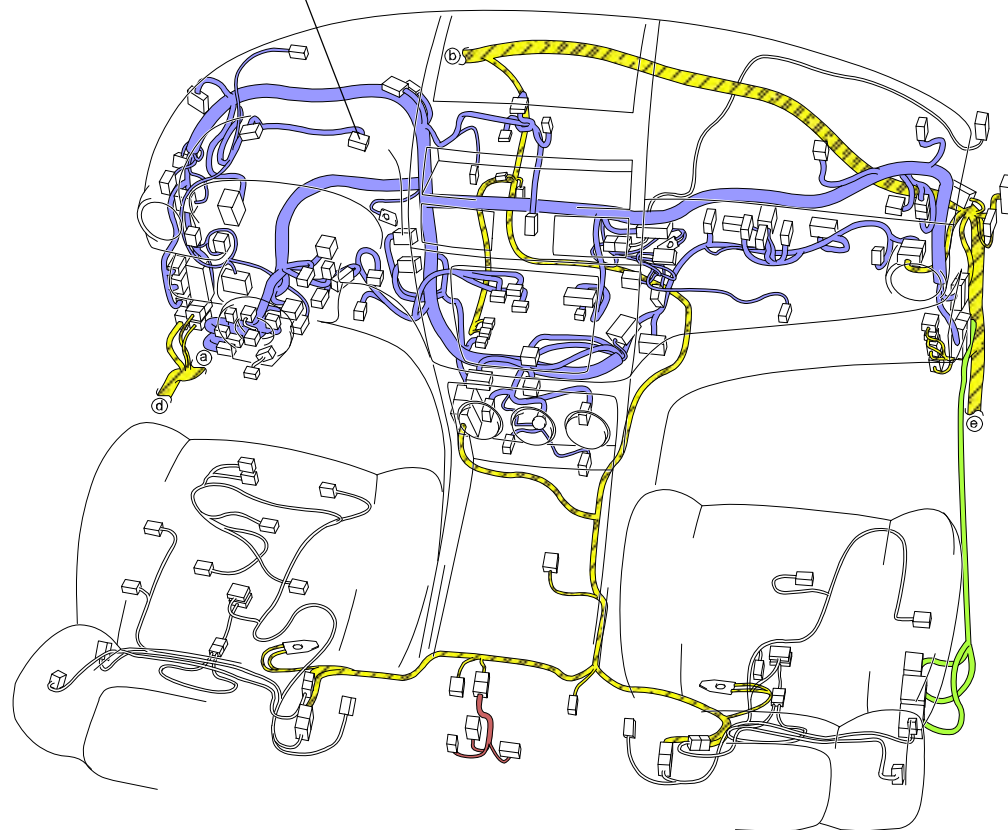

INSTRUMENT CLUSTER
0922-101B



-  : REAR HARNESS
-  : REAR NO.5 HARNESS
-  : INSTRUMENT PANEL HARNESS
-  : FLOOR HARNESS

[EXCEPT MZR-CD (RF Turbo)]

[MZR-CD (RF Turbo)]

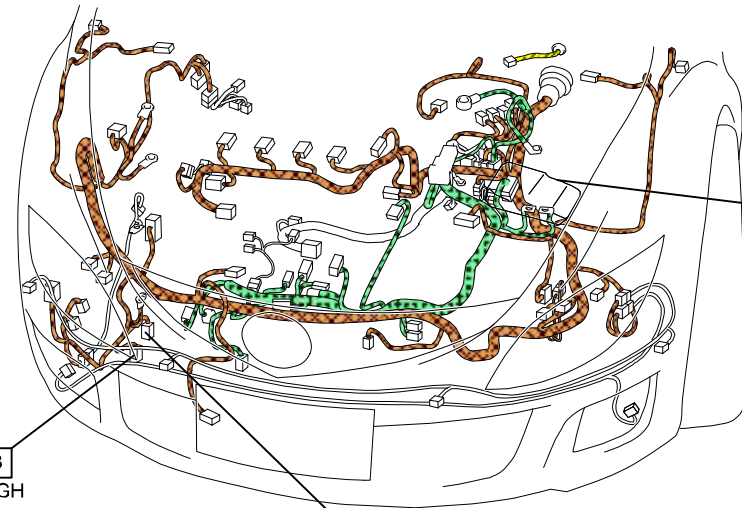
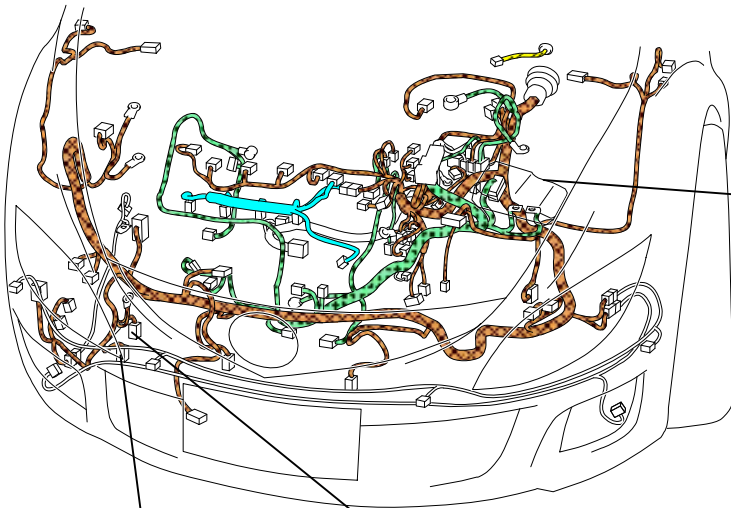

F-01
MAIN FUSE BLOCK
(REFER TO 00F
SECTION)

F-01
MAIN FUSE
BLOCK
(REFER TO
00F SECTION)

0922-203
HORN HIGH
[BLACK]

0922-204
HORN LOW
[BLACK]







0922-203
HORN HIGH
[BLACK]

0922-204
HORN LOW
[BLACK]

0922-201
CLOCK SPRING

0922-202
CRUISE CONTROL SWITCH /
UP SWITCH / DOWN SWITCH /
STEERING SWITCH ILLUMINATION /
UP SWITCH ILLUMINATION /
DOWN SWITCH ILLUMINATION /
CRUISE CONTROL SWITCH ILLUMINATION /
STEERING SWITCH /
CLOCK SPRING

0922-205
HORN SWITCH

-  : FRONT HARNESS
-  : ENGINE HARNESS
-  : INJECTION HARNESS
-  : REAR HARNESS
-  : REAR NO.5 HARNESS
-  : INSTRUMENT PANEL HARNESS
-  : FLOOR HARNESS

INFORMATION DISPLAY

0922-3a

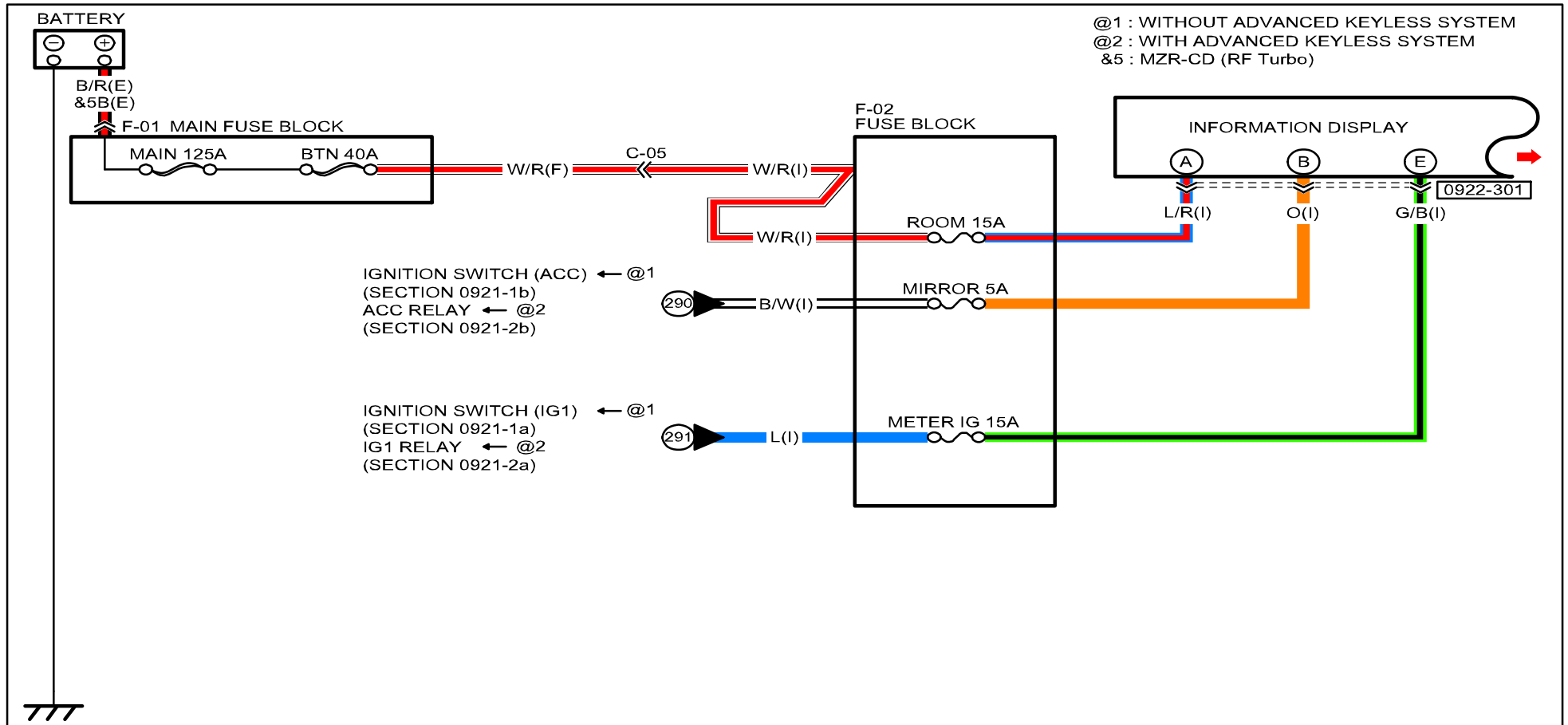

<p>0922-301 INFORMATION DISPLAY</p>					

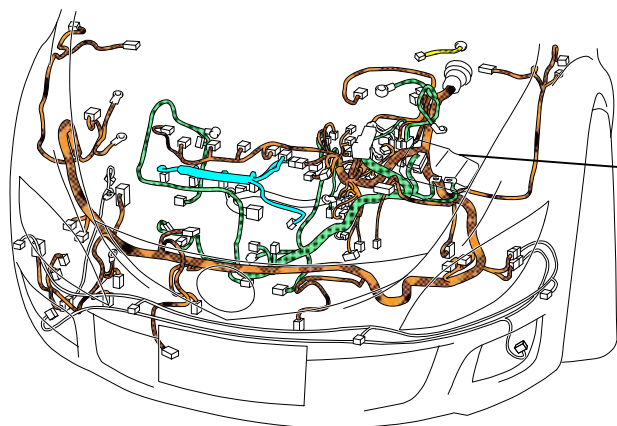

F-01
MAIN FUSE BLOCK
(REFER TO 00F SECTION)

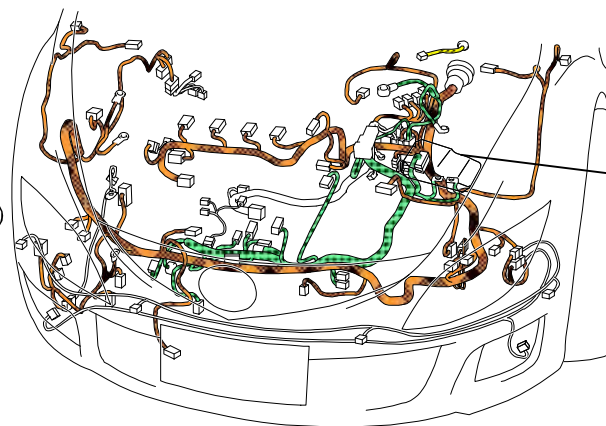

F-01
MAIN FUSE BLOCK
(REFER TO 00F SECTION)

[EXCEPT MZR-CD (RF Turbo)]

[MZR-CD (RF Turbo)]

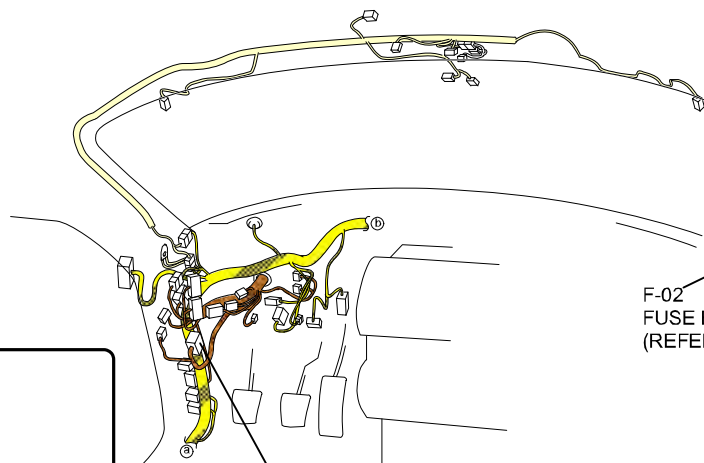





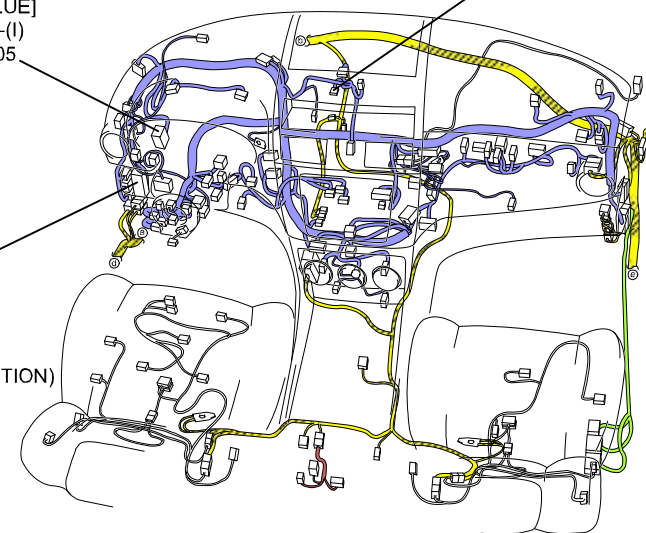



C-05
(F)-(I)
[BLUE]

[BLUE]
(F)-(I)
C-05



F-02
FUSE BLOCK
(REFER TO 00F SECTION)

INFORMATION DISPLAY
0922-301

-  : FRONT HARNESS
-  : ENGINE HARNESS
-  : INJECTION HARNESS
-  : REAR HARNESS
-  : REAR NO.5 HARNESS
-  : INSTRUMENT PANEL HARNESS
-  : FLOOR HARNESS
-  : INTERIOR LIGHT NO.2 HARNESS

C-05

FRONT HARNESS-INSTRUMENT PANEL HARNESS

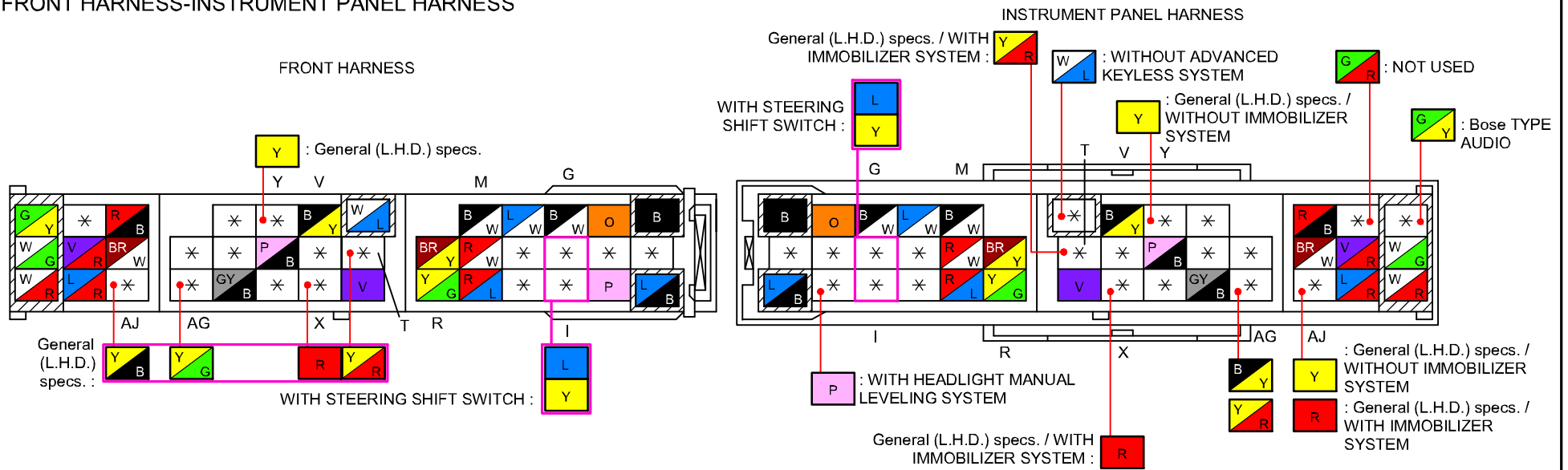

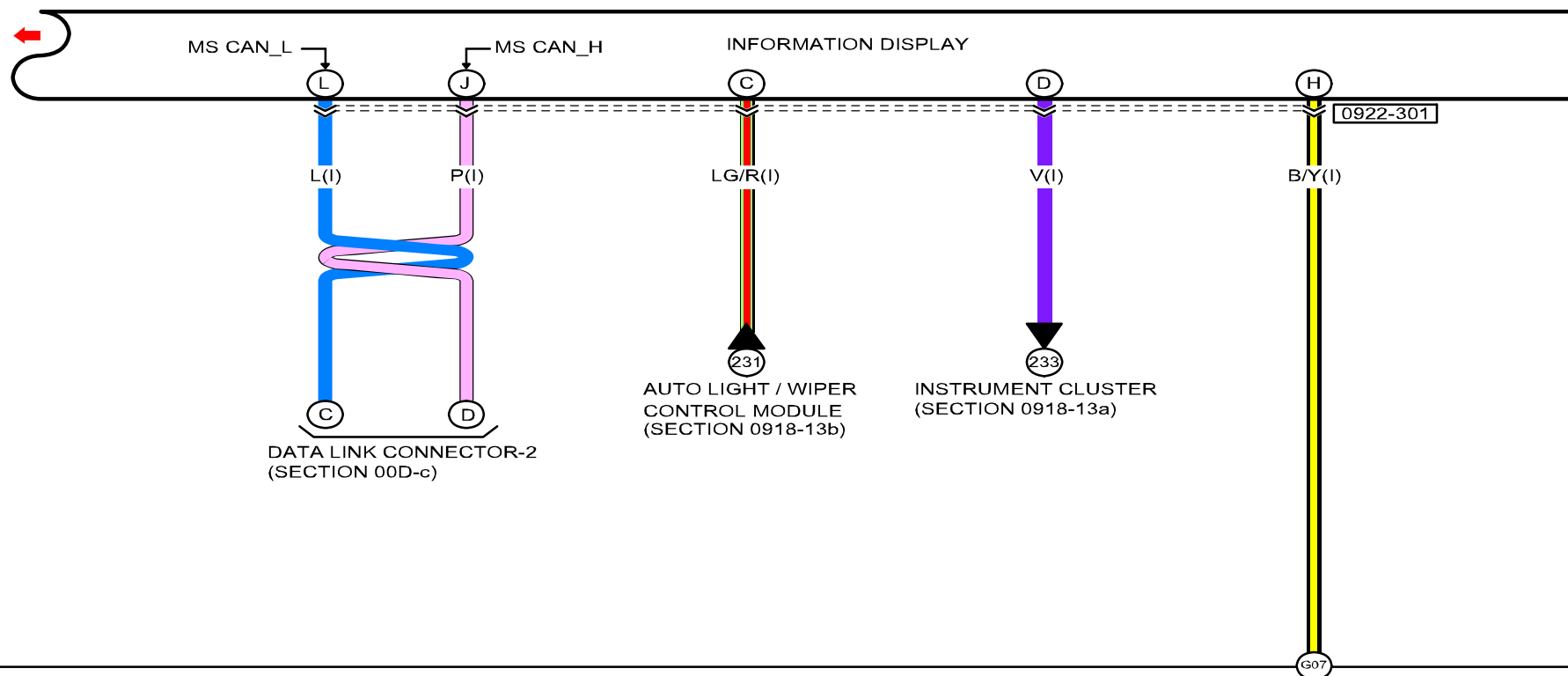



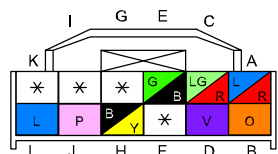

0922-301
INFORMATION DISPLAY

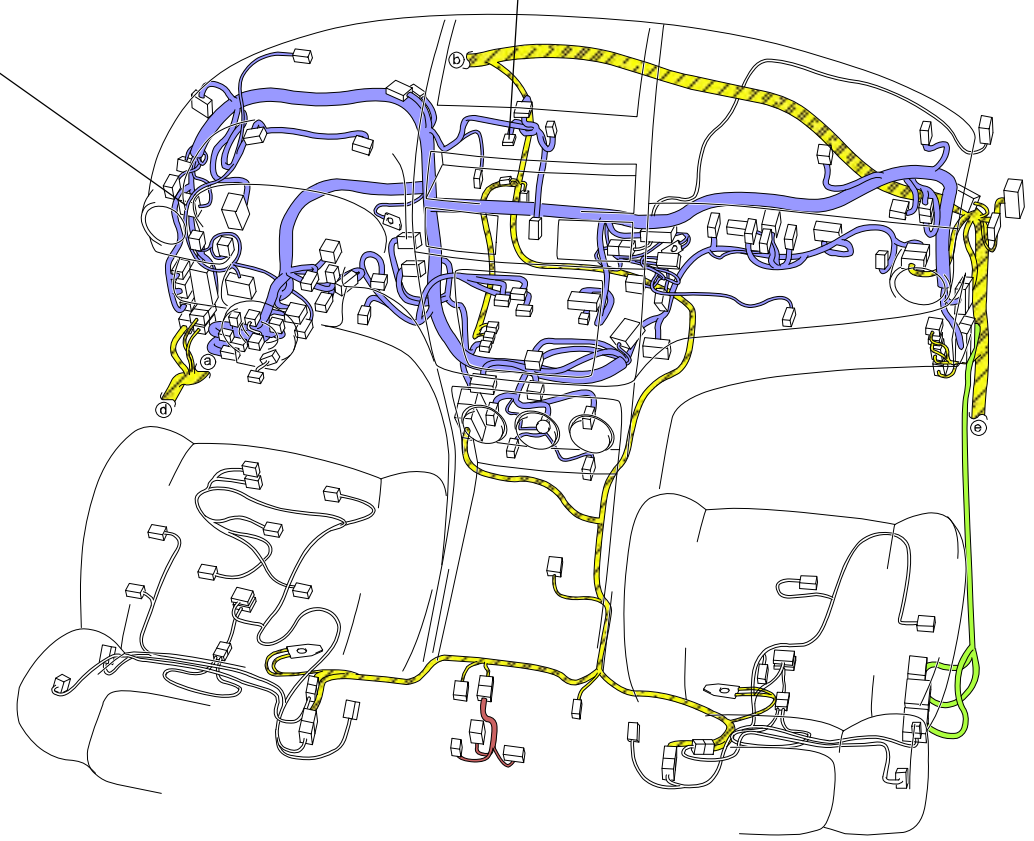

INFORMATION DISPLAY
0922-301

G07



-  : REAR HARNESS
-  : REAR NO.5 HARNESS
-  : INSTRUMENT PANEL HARNESS
-  : FLOOR HARNESS

&1 : WITHOUT THEFT-DETERRENT SYSTEM
 &2 : WITH THEFT-DETERRENT SYSTEM

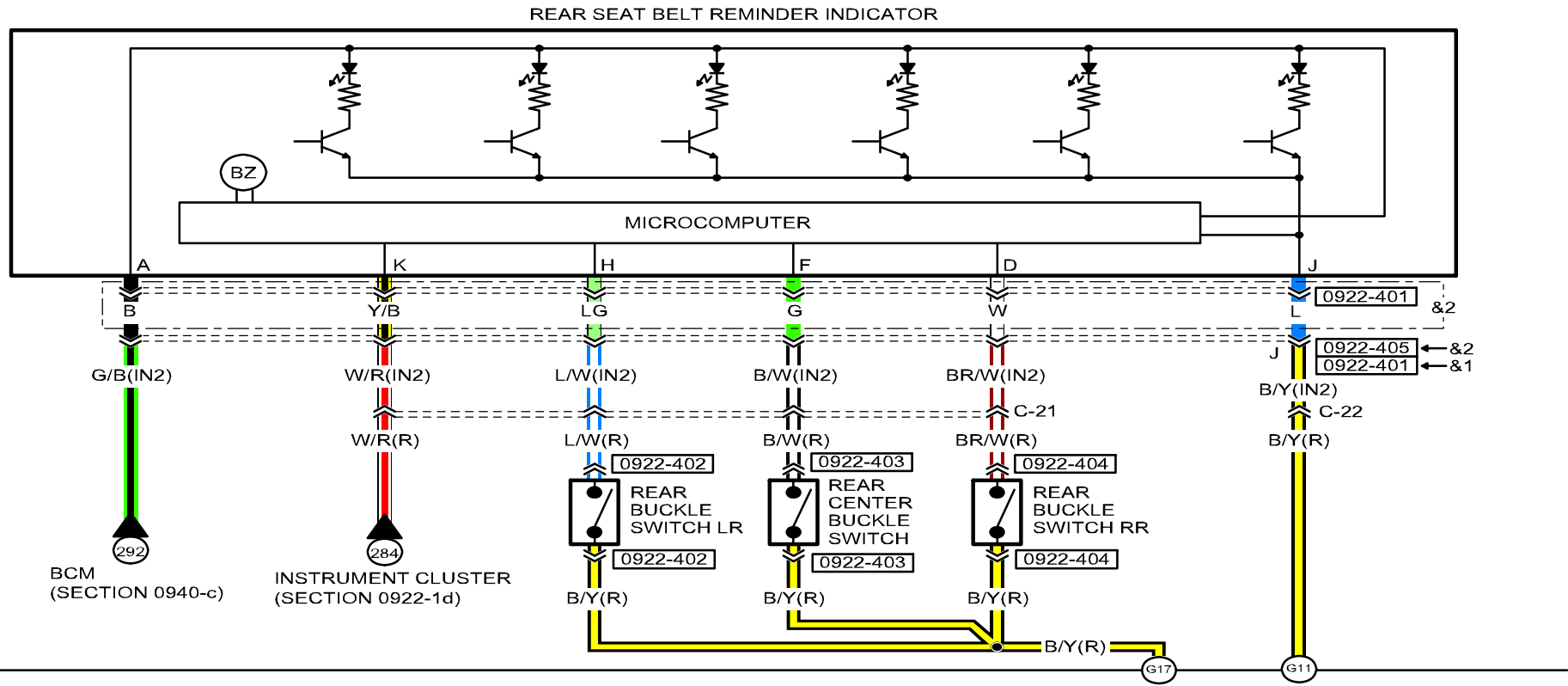

0922-401
 REAR SEAT BELT REMINDER INDICATOR

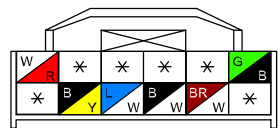

(WITHOUT THEFT-DETERRENT SYSTEM)

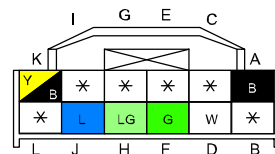

(WITH THEFT-DETERRENT SYSTEM)

0922-404
 REAR BUCKLE SWITCH RR

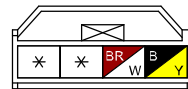

0922-405
 INTERIOR LIGHT NO.2 HARNESS-SHORT CORD

INTERIOR LIGHT NO.2 HARNESS

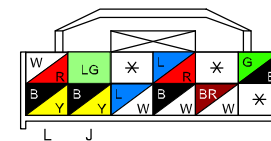

SHORT CORD

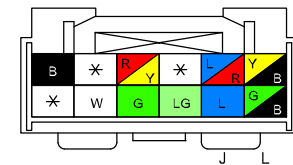

0922-402
 REAR BUCKLE SWITCH LR



0922-403
 REAR CENTER BUCKLE SWITCH

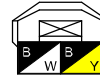

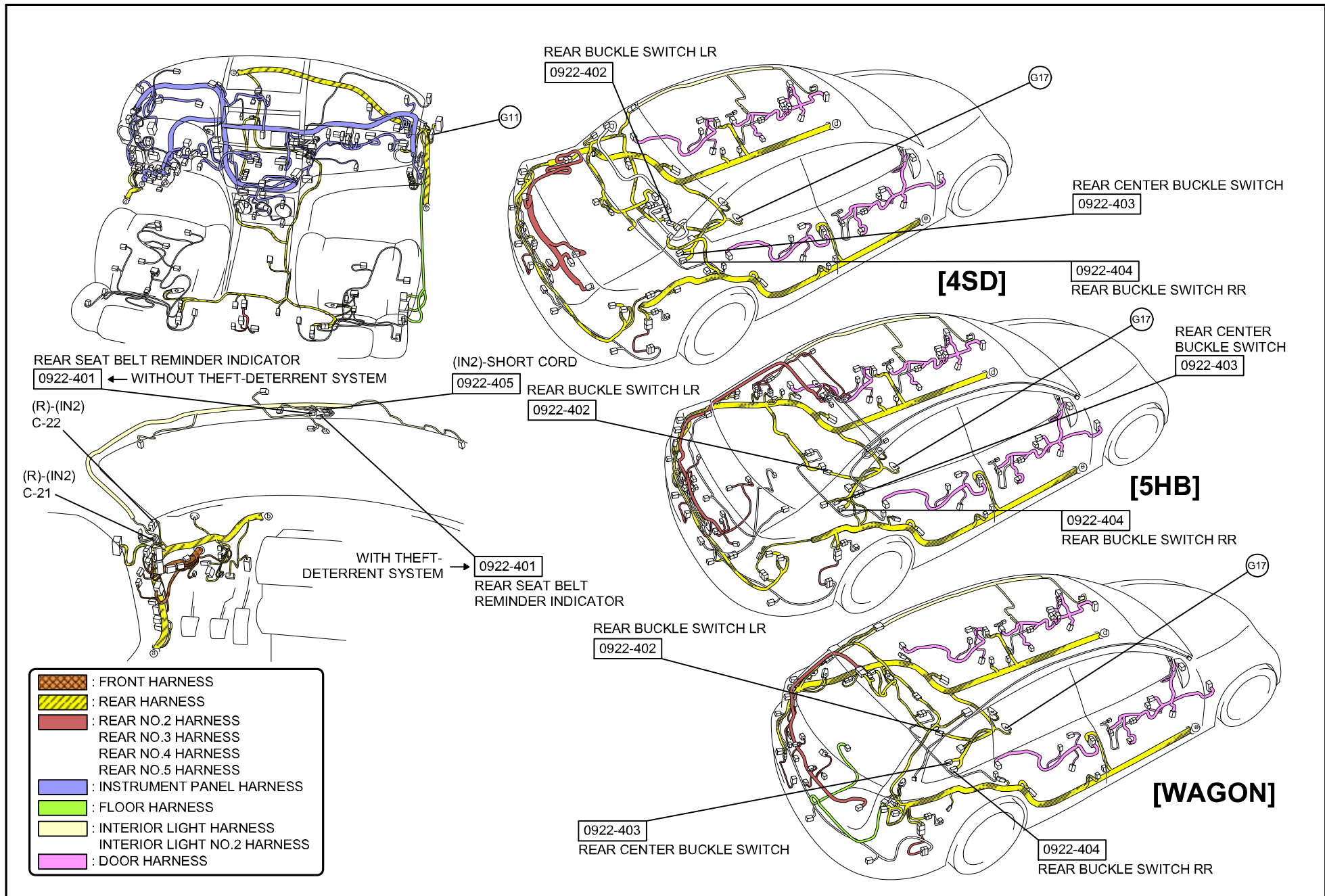

C-21

REAR HARNESS-INTERIOR LIGHT NO.2 HARNESS

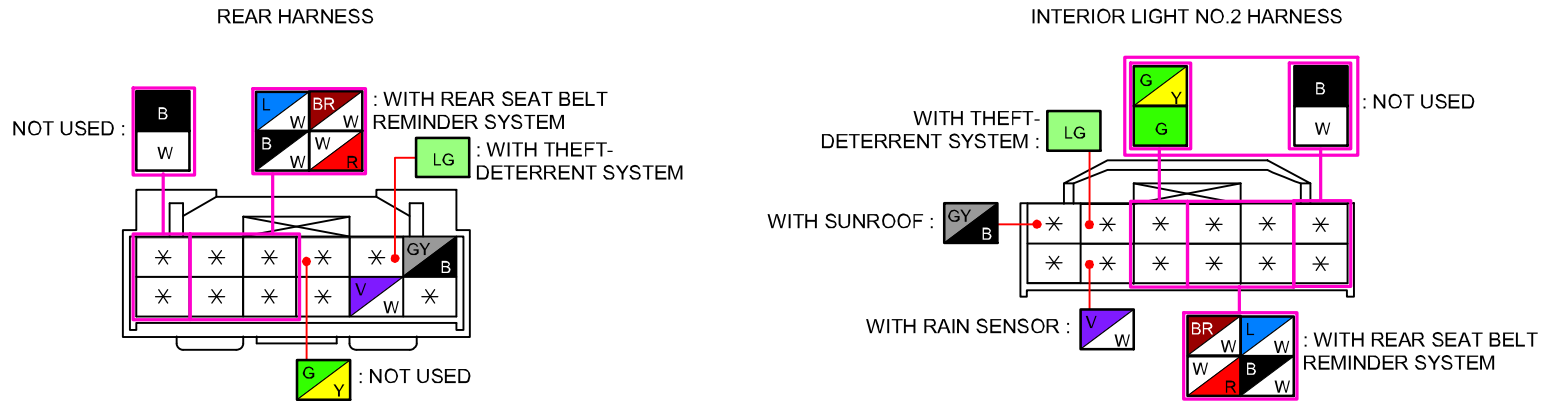

C-22

REAR HARNESS-INTERIOR LIGHT NO.2 HARNESS

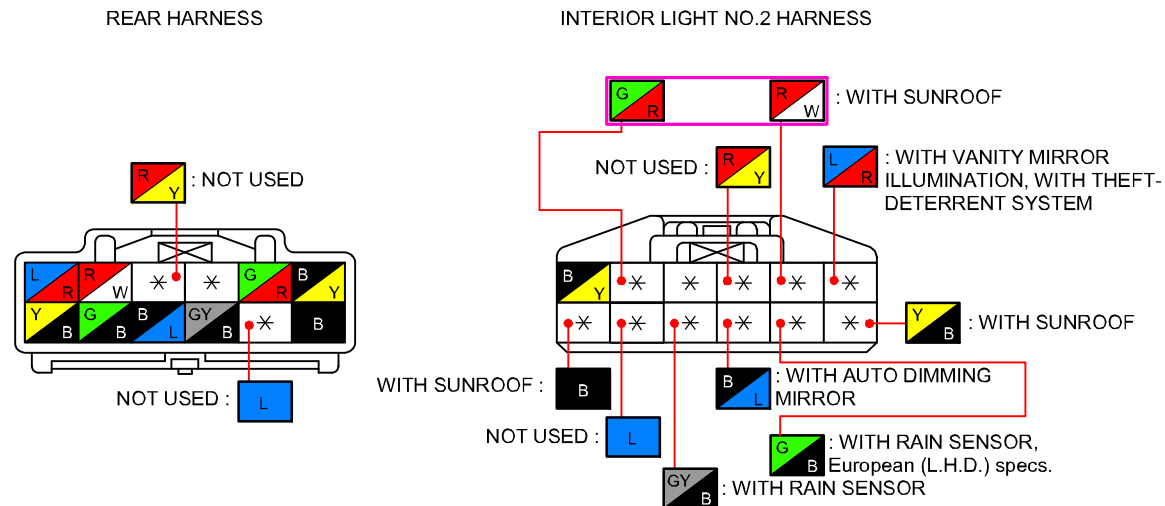

PARKING SENSOR SYSTEM

0922-5a

IGNITION SWITCH (IG1) ← @1
 (SECTION 0921-1a)
 IG1 RELAY ← @2
 (SECTION 0921-2a)

@1 : WITHOUT ADVANCED KEYLESS SYSTEM
 @2 : WITH ADVANCED KEYLESS SYSTEM

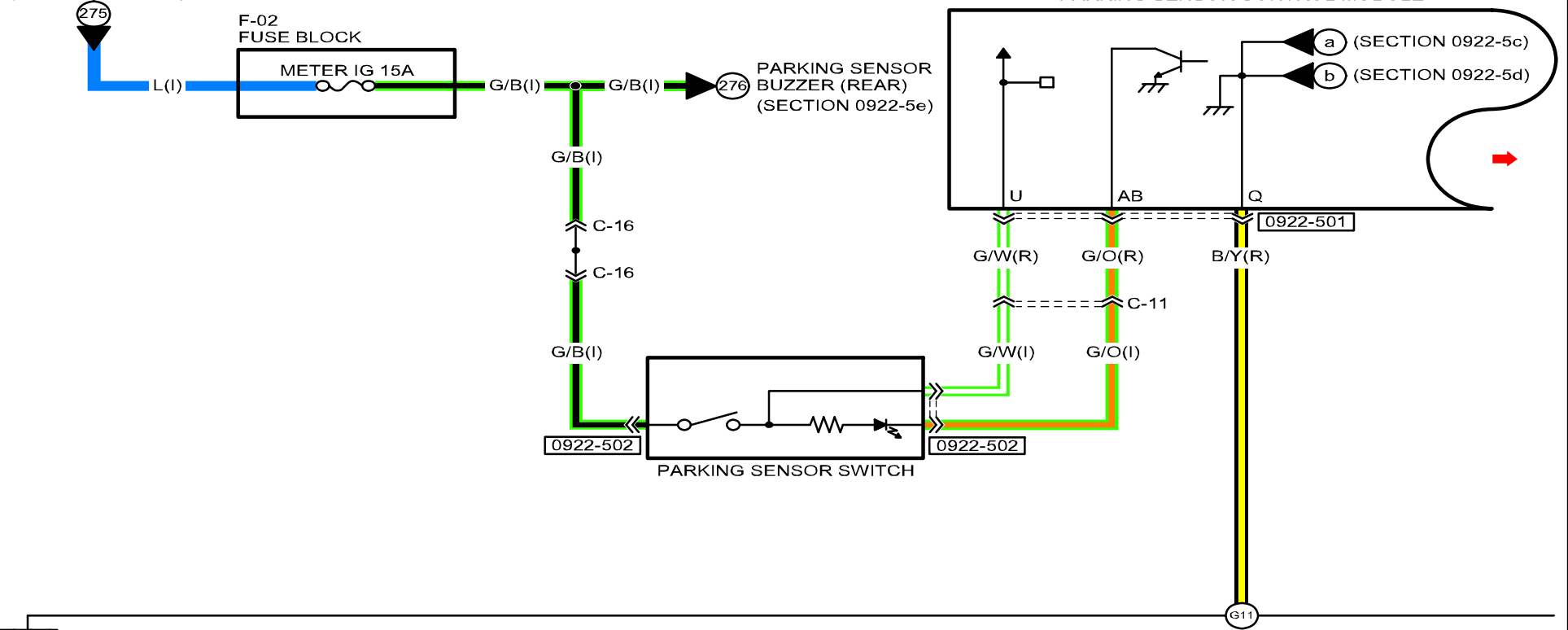

0922-501
 PARKING SENSOR CONTROL MODULE

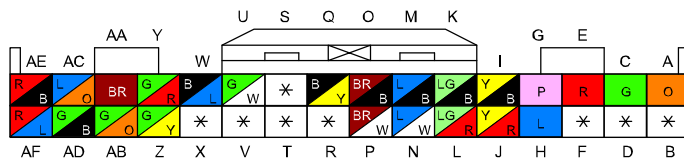

0922-502
 PARKING SENSOR SWITCH ILLUMINATION /
 PARKING SENSOR SWITCH

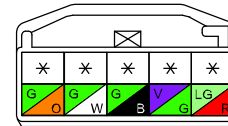

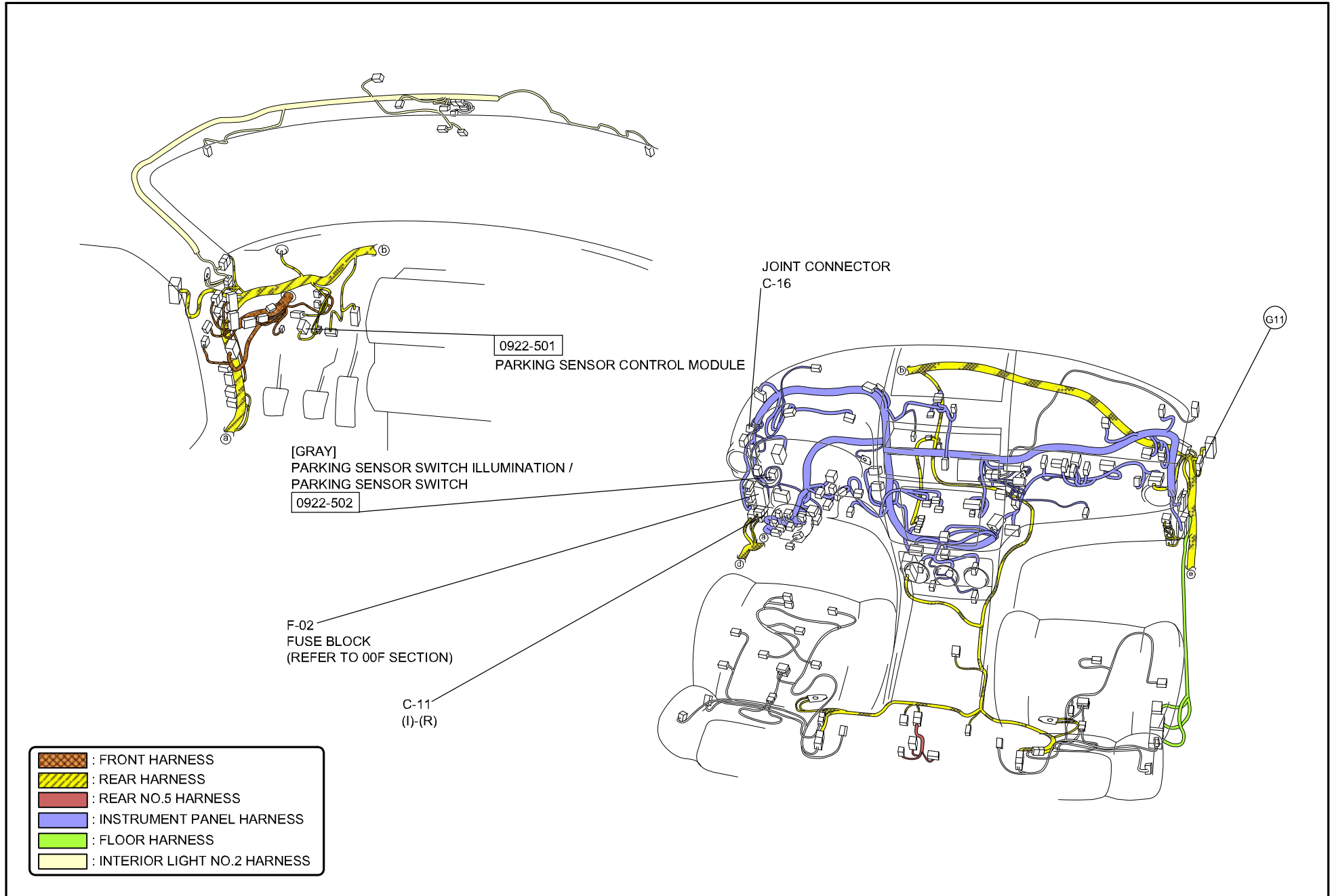

C-11
INSTRUMENT PANEL HARNESS-REAR HARNESS

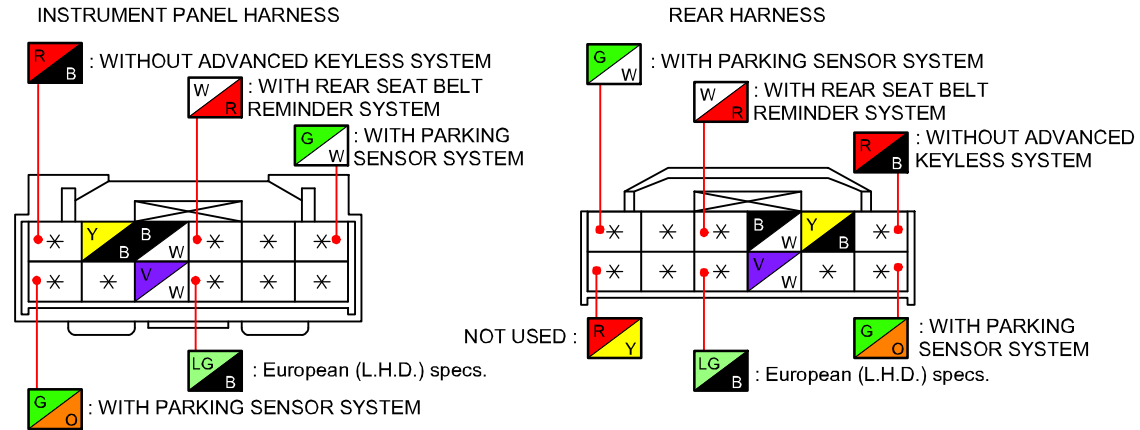

C-16
JOINT CONNECTOR

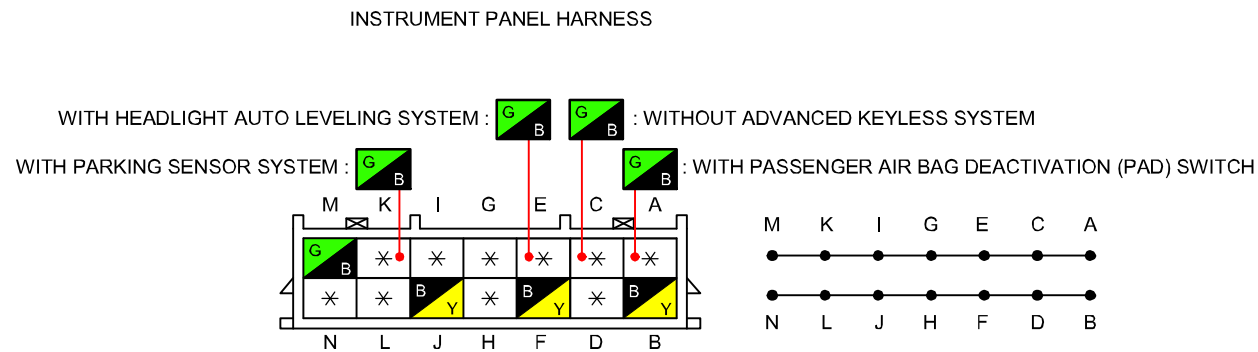

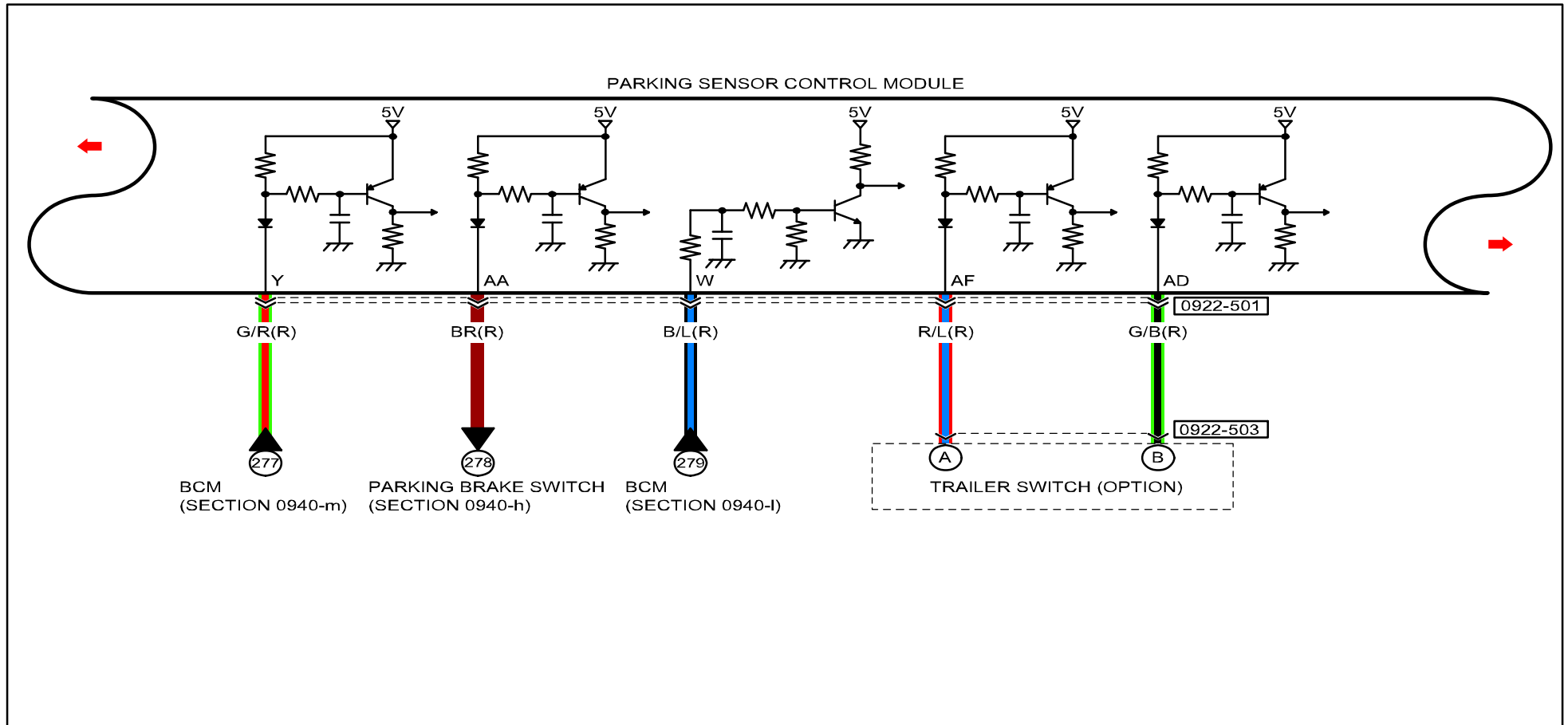









<p>0922-501 PARKING SENSOR CONTROL MODULE</p>	<p>0922-503 TRAILER SWITCH (OPTION)</p>					

PARKING SENSOR SYSTEM

0922-5b

-  : FRONT HARNESS
-  : REAR HARNESS
-  : REAR NO.2 HARNESS
-  : REAR NO.3 HARNESS
-  : REAR NO.4 HARNESS
-  : DOOR HARNESS
-  : INTERIOR LIGHT HARNESS
-  : INTERIOR LIGHT NO.2 HARNESS
-  : FLOOR HARNESS

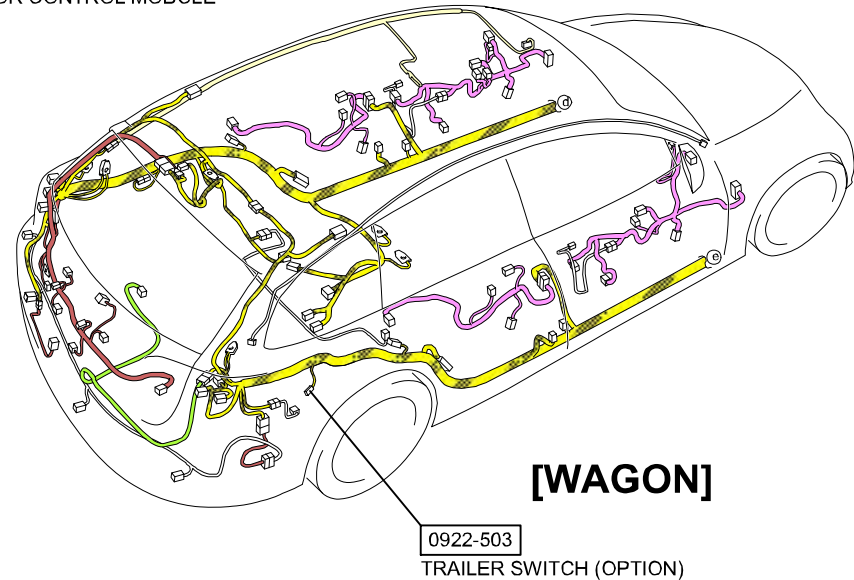
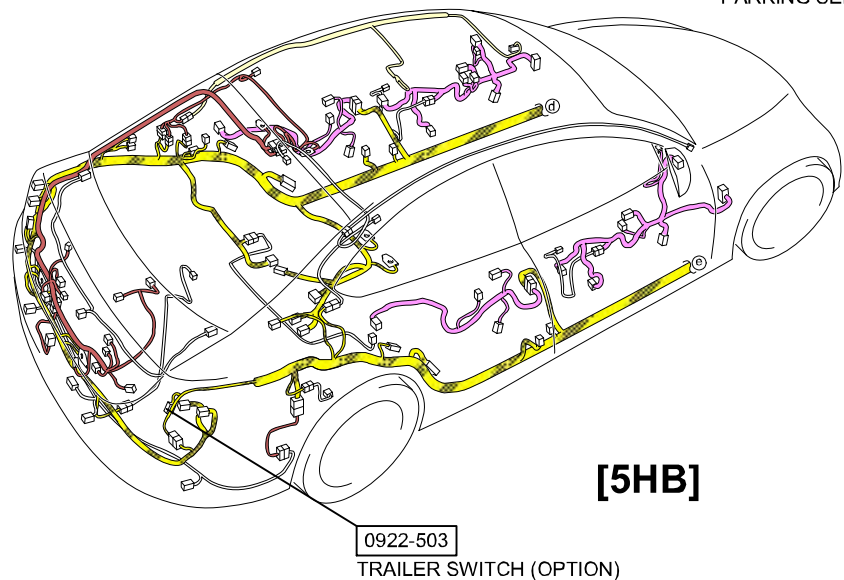
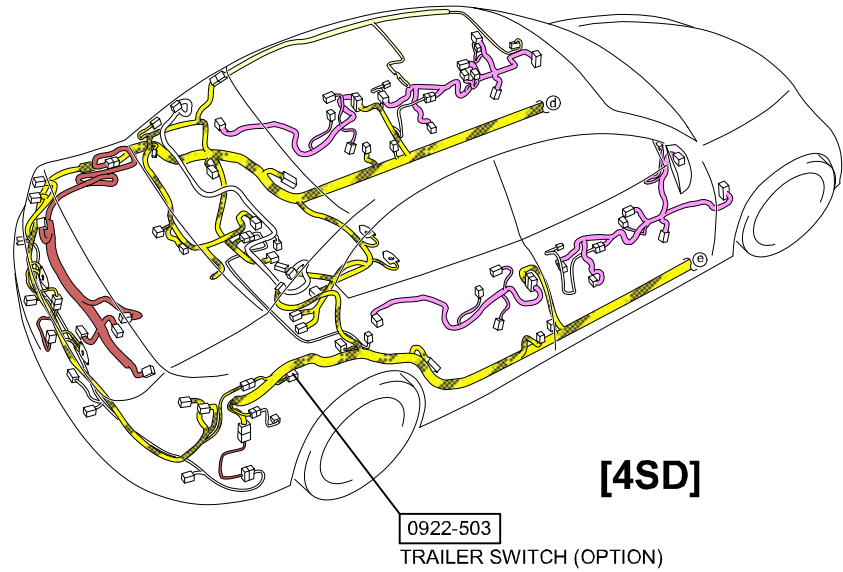
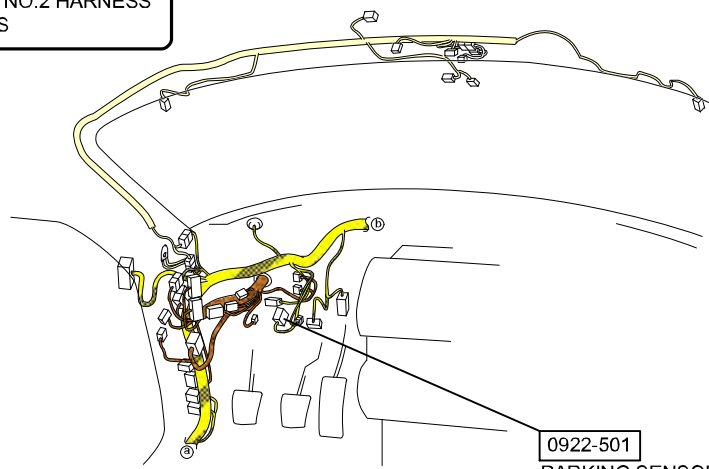

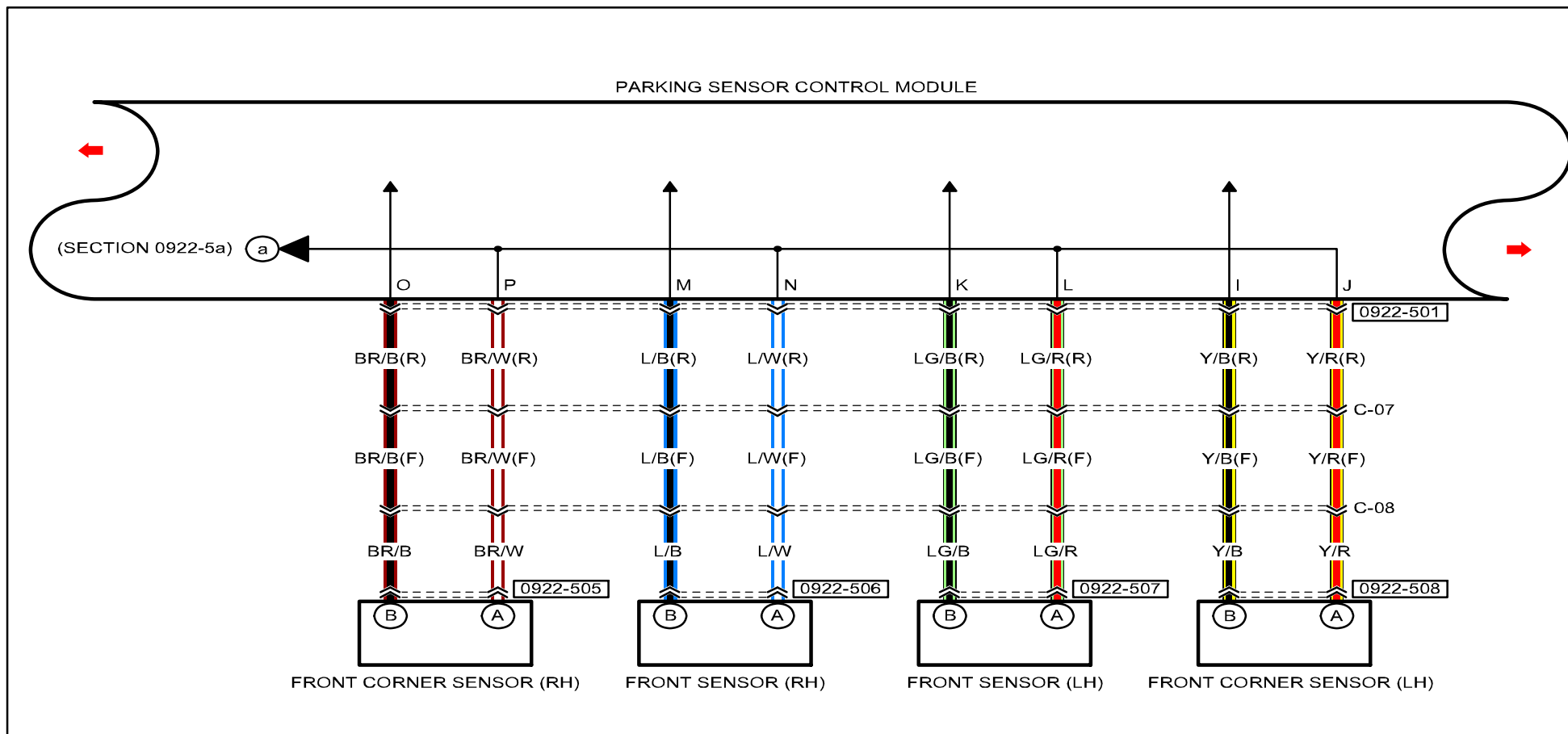

<p>0922-501 PARKING SENSOR CONTROL MODULE</p>	<p>0922-505 FRONT CORNER SENSOR (RH)</p>	<p>0922-506 FRONT SENSOR (RH)</p>	<p>0922-507 FRONT SENSOR (LH)</p>	<p>0922-508 FRONT CORNER SENSOR (LH)</p>
Empty space for additional notes or diagrams	Empty space for additional notes or diagrams	Empty space for additional notes or diagrams	Empty space for additional notes or diagrams	Empty space for additional notes or diagrams

[EXCEPT MZR-CD (RF Turbo)]

[MZR-CD (RF Turbo)]

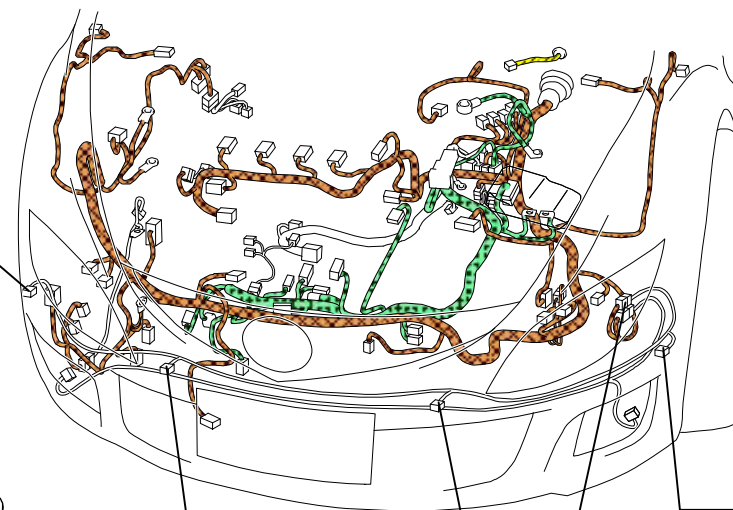
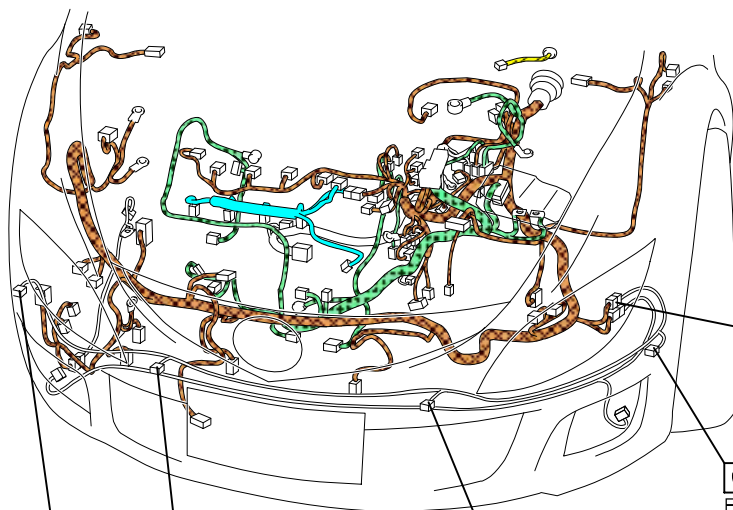

- [BLACK]
FRONT CORNER
SENSOR (RH)
0922-505
- C-08
(F)-SHORT CORD
[GRAY]
- 0922-508
FRONT CORNER SENSOR (LH)
[BLACK]
- 0922-506
FRONT SENSOR (RH)
[BLACK]
- 0922-507
FRONT SENSOR (LH)
[BLACK]
- 0922-505
FRONT CORNER SENSOR (RH)
[BLACK]
- 0922-506
FRONT SENSOR (RH)
[BLACK]
- 0922-508
FRONT
CORNER
SENSOR (LH)
[BLACK]
- C-08
(F)-SHORT CORD
[GRAY]
- 0922-507
FRONT SENSOR (LH)
[BLACK]

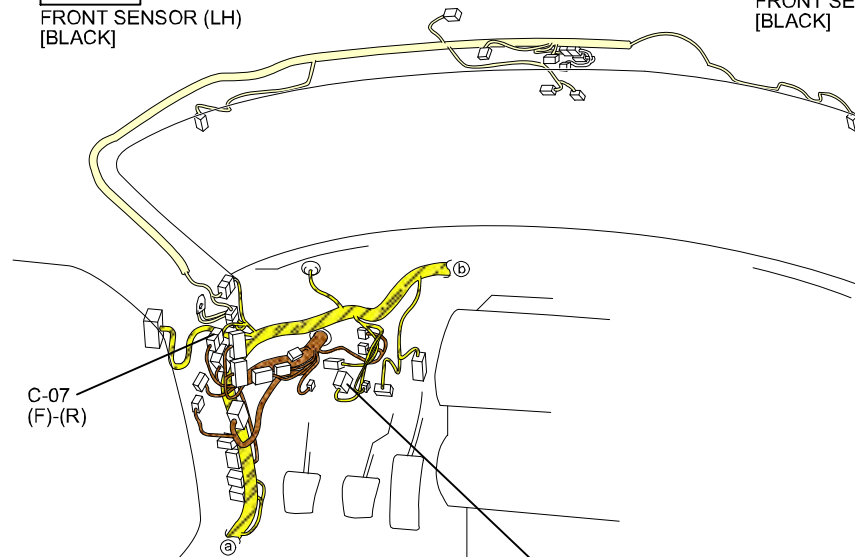

- C-07
(F)-(R)
- 0922-501
PARKING SENSOR CONTROL MODULE

	: FRONT HARNESS
	: ENGINE HARNESS
	: INJECTION HARNESS
	: REAR HARNESS
	: INTERIOR LIGHT NO.2 HARNESS

C-07
FRONT HARNESS-REAR HARNESS

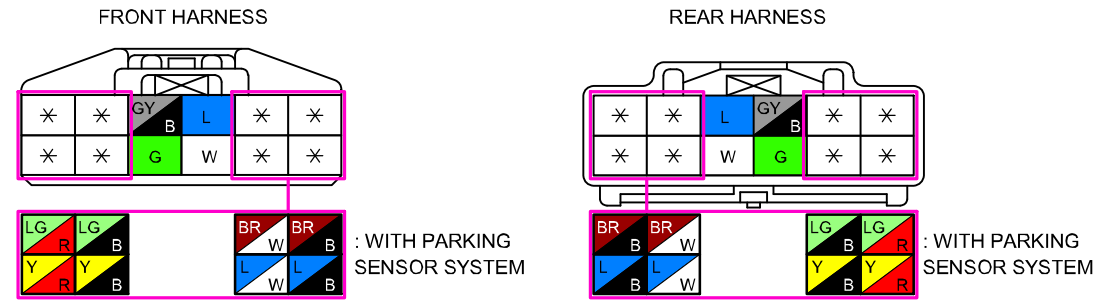

C-08
FRONT HARNESS-SHORT CORD

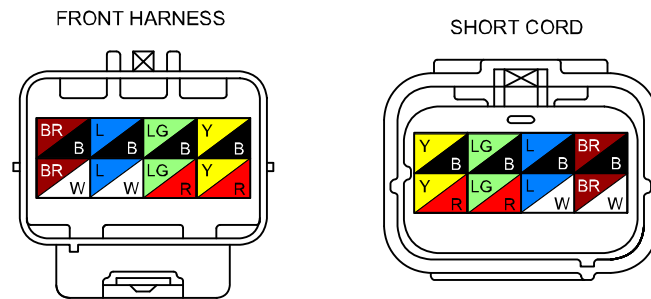



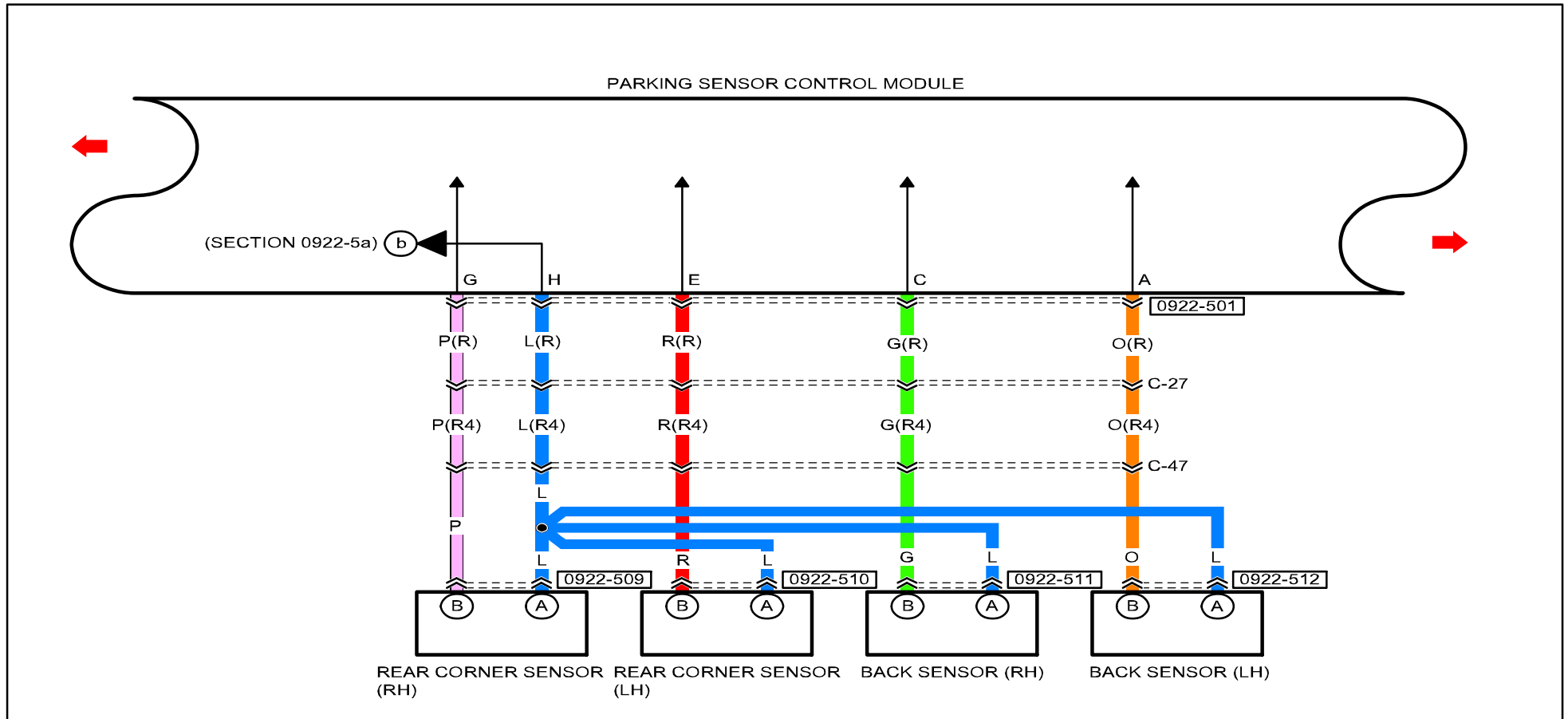





(WITH PARKING SENSOR SYSTEM)



<p>0922-501 PARKING SENSOR CONTROL MODULE</p>	<p>0922-509 REAR CORNER SENSOR (RH)</p>	<p>0922-510 REAR CORNER SENSOR (LH)</p>	<p>0922-511 BACK SENSOR (RH)</p>	<p>0922-512 BACK SENSOR (LH)</p>
Empty space for notes or additional diagrams	Empty space for notes or additional diagrams	Empty space for notes or additional diagrams	Empty space for notes or additional diagrams	Empty space for notes or additional diagrams

PARKING SENSOR SYSTEM

0922-5d

-  : FRONT HARNESS
-  : REAR HARNESS
-  : REAR NO.2 HARNESS
-  : REAR NO.3 HARNESS
-  : REAR NO.4 HARNESS
-  : DOOR HARNESS
-  : INTERIOR LIGHT HARNESS
-  : INTERIOR LIGHT NO.2 HARNESS
-  : FLOOR HARNESS

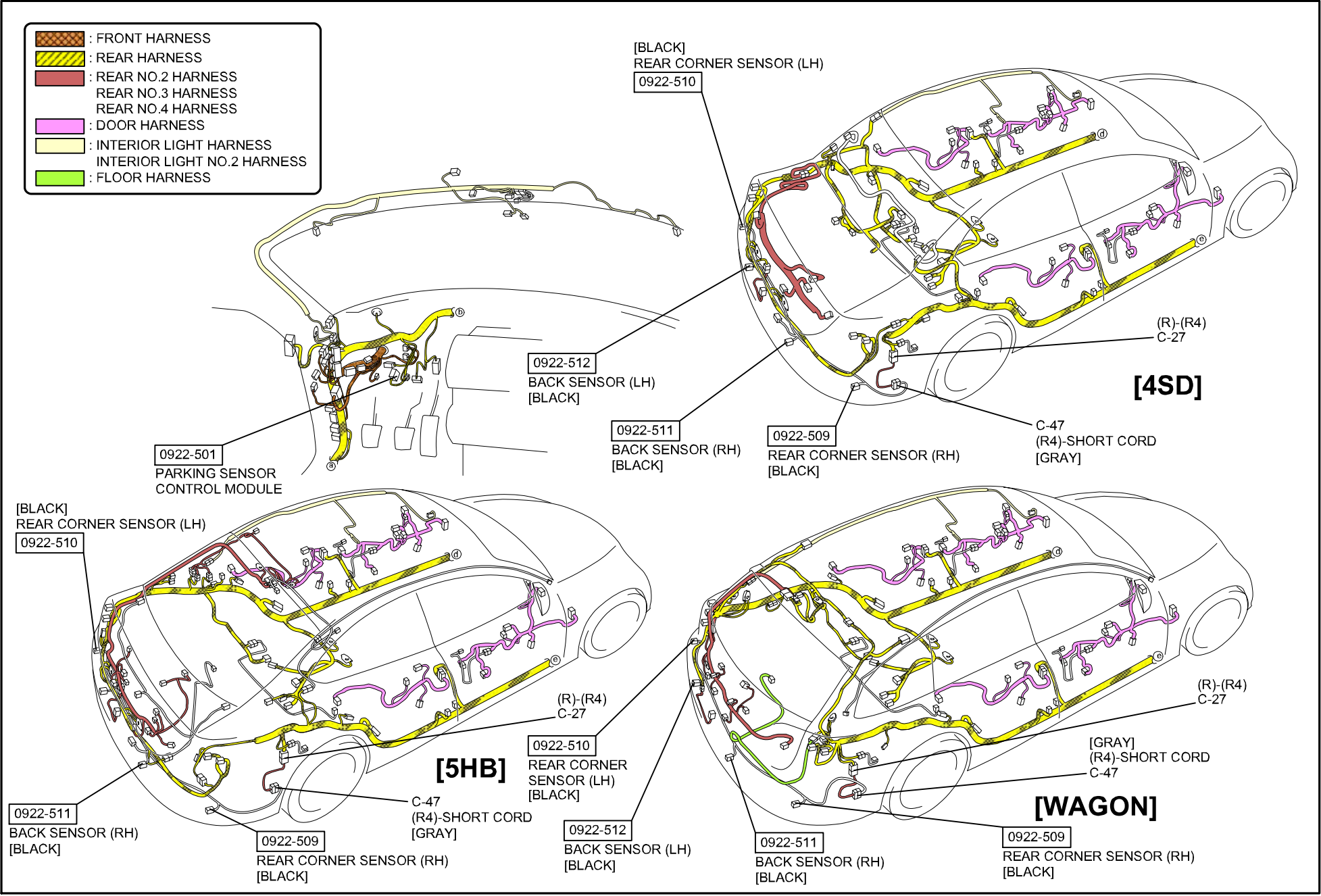

0922-501
PARKING SENSOR CONTROL MODULE

0922-512
BACK SENSOR (LH)
[BLACK]

0922-511
BACK SENSOR (RH)
[BLACK]

[BLACK]
REAR CORNER SENSOR (LH)
0922-510

0922-509
REAR CORNER SENSOR (RH)
[BLACK]

[4SD]

(R)-(R4)
C-27

C-47
(R4)-SHORT CORD
[GRAY]

[BLACK]
REAR CORNER SENSOR (LH)
0922-510

0922-511
BACK SENSOR (RH)
[BLACK]

0922-509
REAR CORNER SENSOR (RH)
[BLACK]

[5HB]

0922-510
REAR CORNER SENSOR (LH)
[BLACK]

0922-512
BACK SENSOR (LH)
[BLACK]

(R)-(R4)
C-27

C-47
(R4)-SHORT CORD
[GRAY]

[WAGON]

(R)-(R4)
C-27

[GRAY]
(R4)-SHORT CORD
C-47

0922-511
BACK SENSOR (RH)
[BLACK]

0922-509
REAR CORNER SENSOR (RH)
[BLACK]

PARKING SENSOR SYSTEM

0922-5d

C-27

REAR HARNESS-REAR NO.4 HARNESS

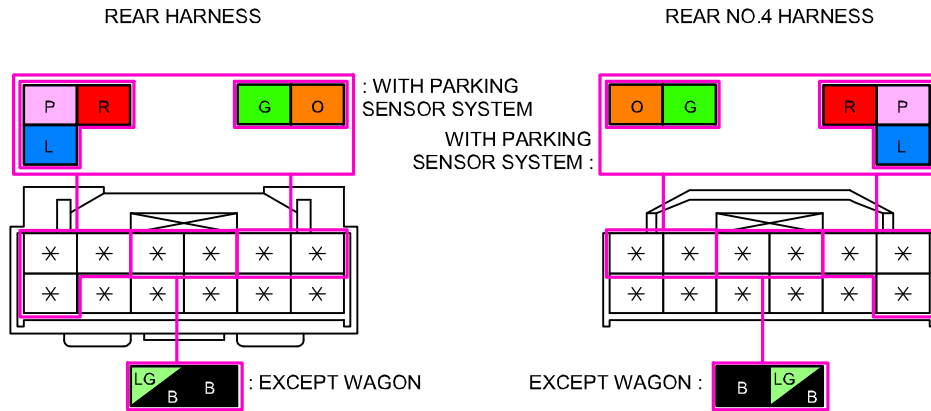

C-47

REAR NO.4 HARNESS-SHORT CORD

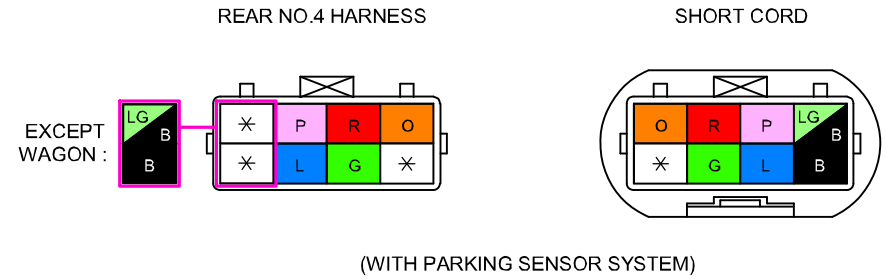

@1 : WITHOUT ADVANCED KEYLESS SYSTEM
 @2 : WITH ADVANCED KEYLESS SYSTEM
 @8 : 4SD

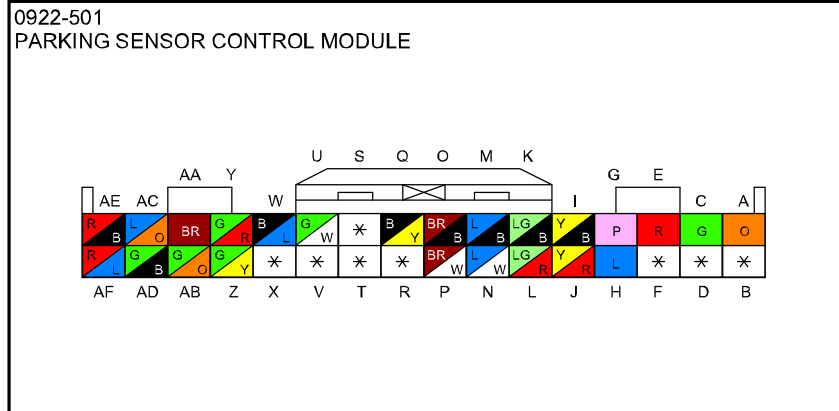
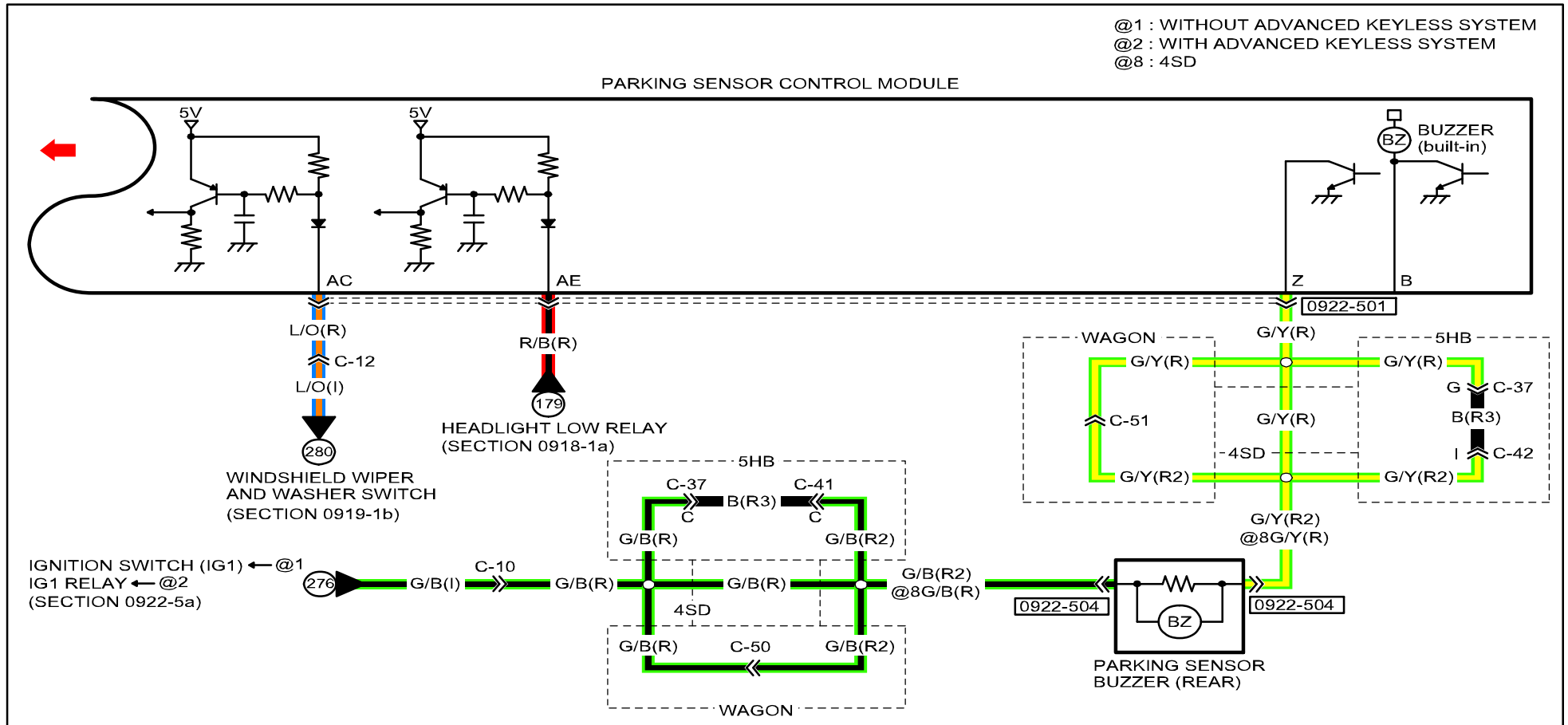

PARKING SENSOR SYSTEM

0922-5e

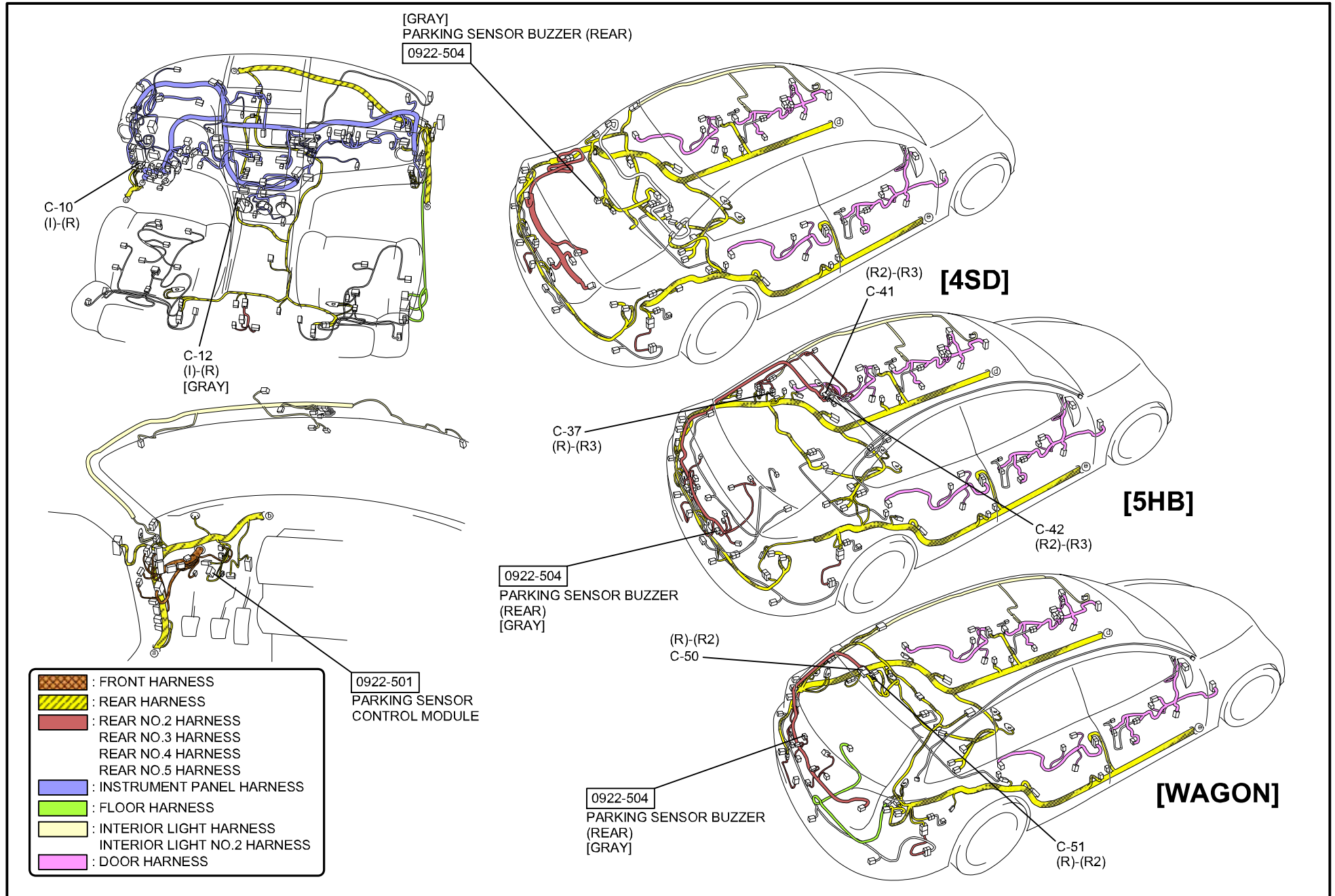

PARKING SENSOR SYSTEM

0922-5e

C-10 INSTRUMENT PANEL HARNESS-REAR HARNESS

INSTRUMENT PANEL HARNESS

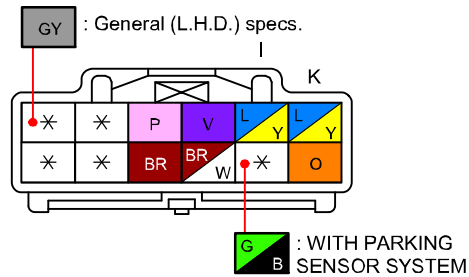

REAR HARNESS

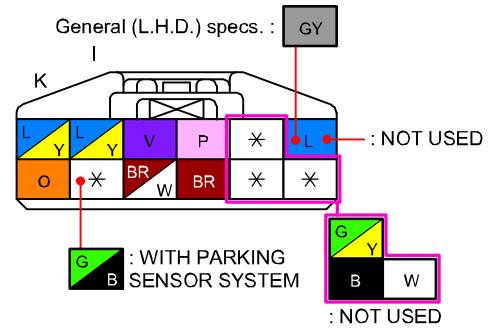

C-12 INSTRUMENT PANEL HARNESS-REAR HARNESS

INSTRUMENT PANEL HARNESS

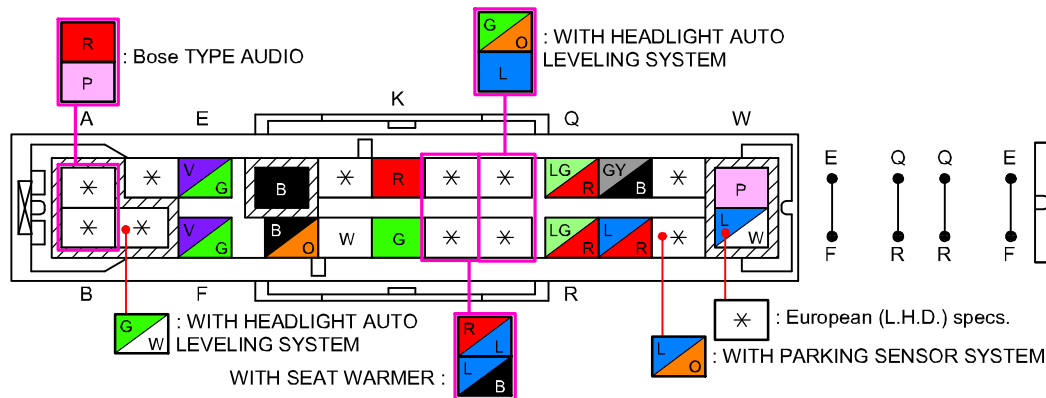

REAR HARNESS

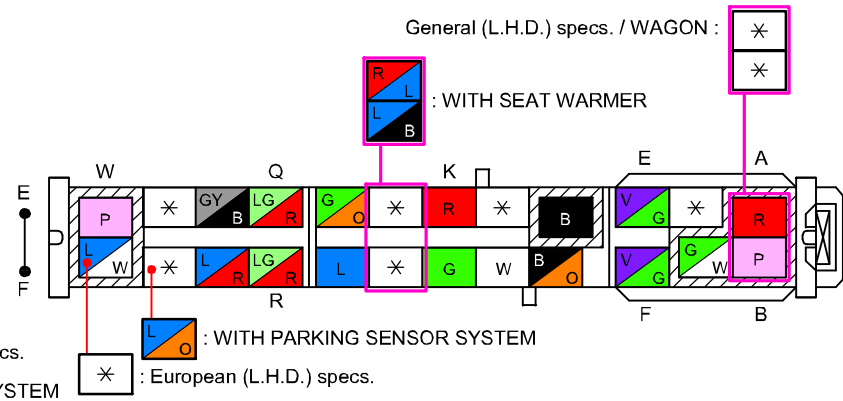

PARKING SENSOR SYSTEM

0922-5e

C-37
REAR HARNESS-REAR NO.3 HARNESS

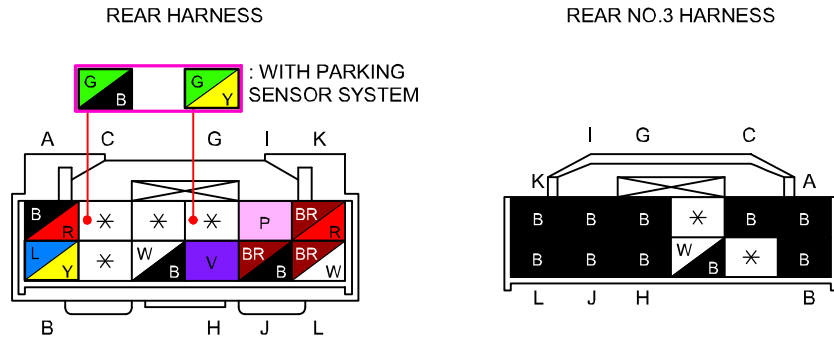

(5HB)

C-41
REAR NO.2 HARNESS-REAR NO.3 HARNESS

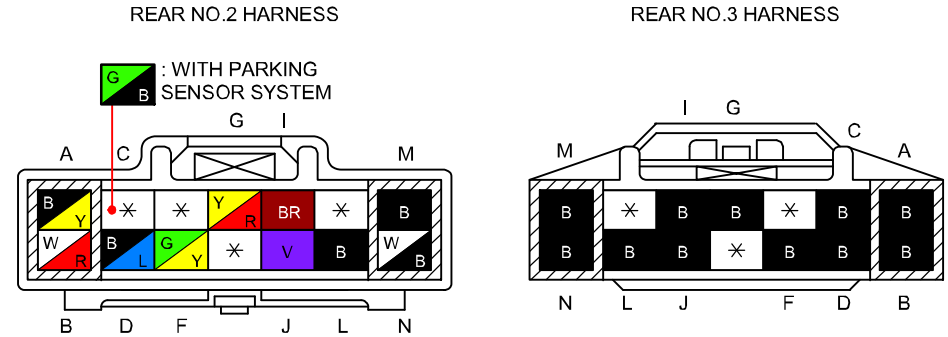

(5HB)

C-42
REAR NO.2 HARNESS-REAR NO.3 HARNESS

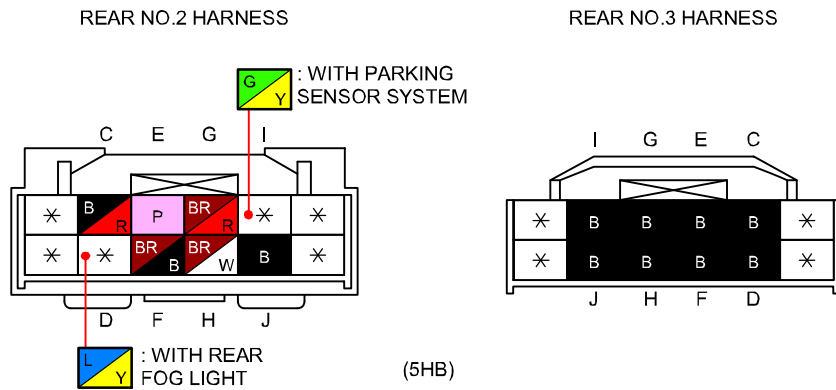

(5HB)

C-50
REAR HARNESS-REAR NO.2 HARNESS

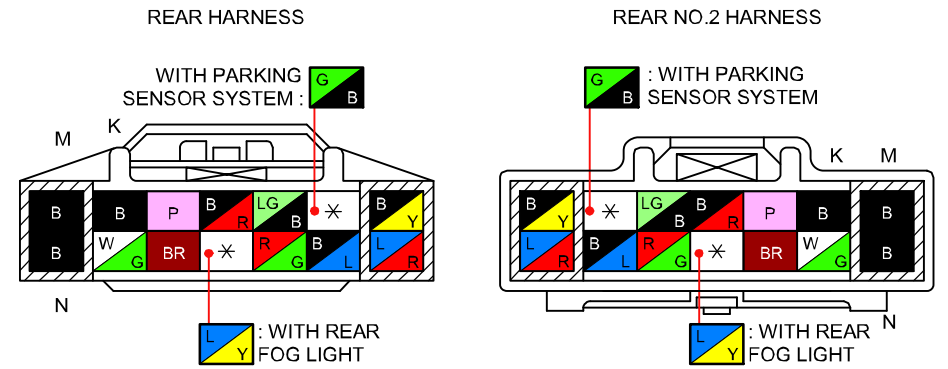

(WAGON)

PARKING SENSOR SYSTEM

0922-5e

C-51
REAR HARNESS-REAR NO.2 HARNESS

REAR HARNESS

WITH ADVANCED
KEYLESS SYSTEM :

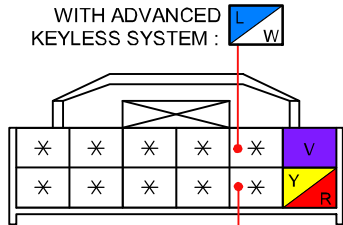

G Y : WITH PARKING
SENSOR SYSTEM

REAR NO.2 HARNESS

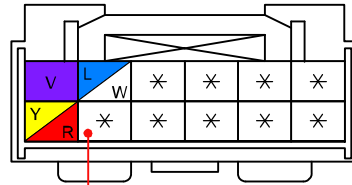

G Y : WITH PARKING
SENSOR SYSTEM

(WAGON)

BCM (BODY CONTROL MODULE)

0940-a

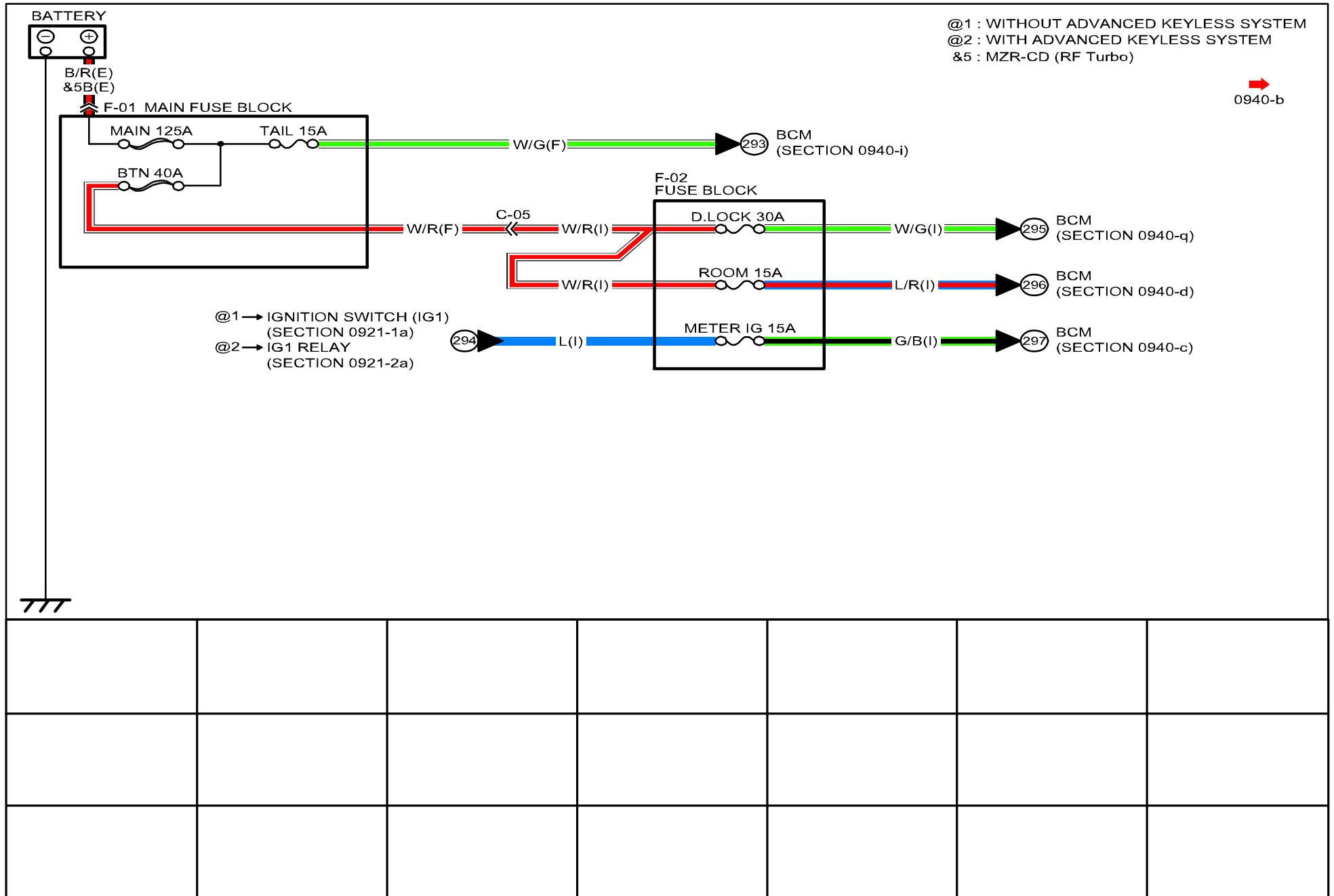

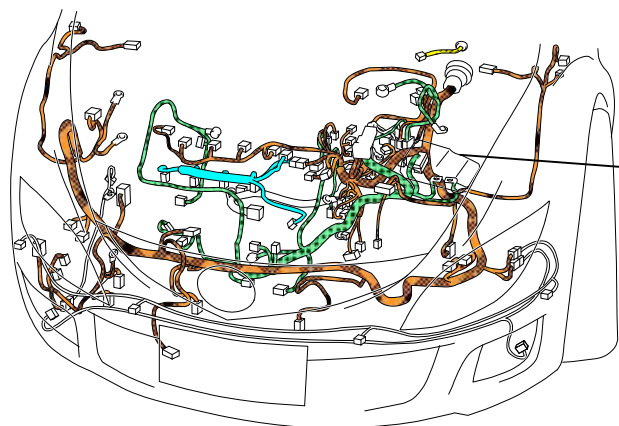

F-01
MAIN FUSE BLOCK
(REFER TO 00F SECTION)

[EXCEPT MZR-CD (RF Turbo)]

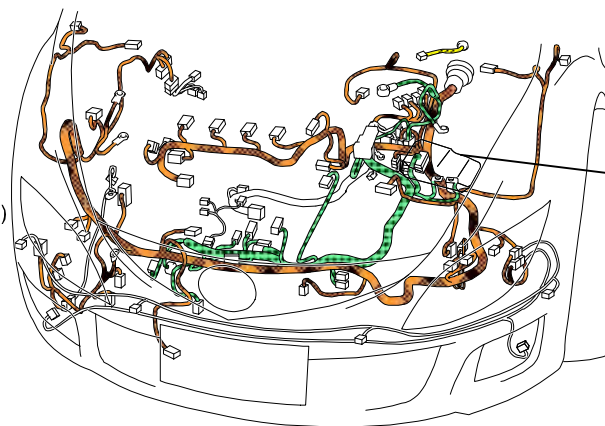

F-01
MAIN FUSE BLOCK
(REFER TO 00F SECTION)

[MZR-CD (RF Turbo)]

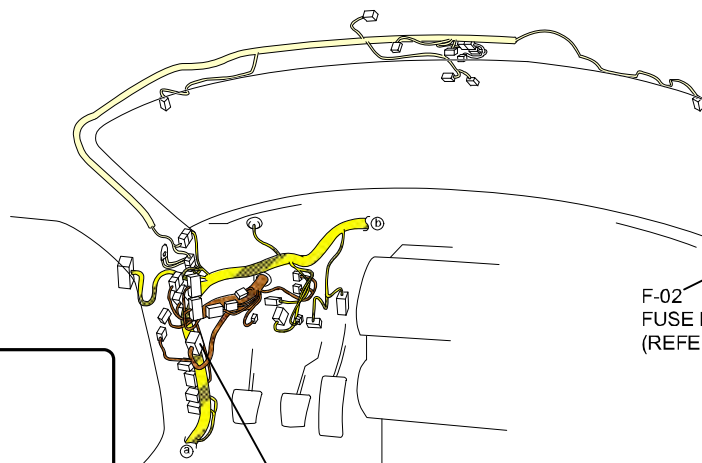

C-05
(F)-(I)
[BLUE]

[BLUE]
(F)-(I)
C-05

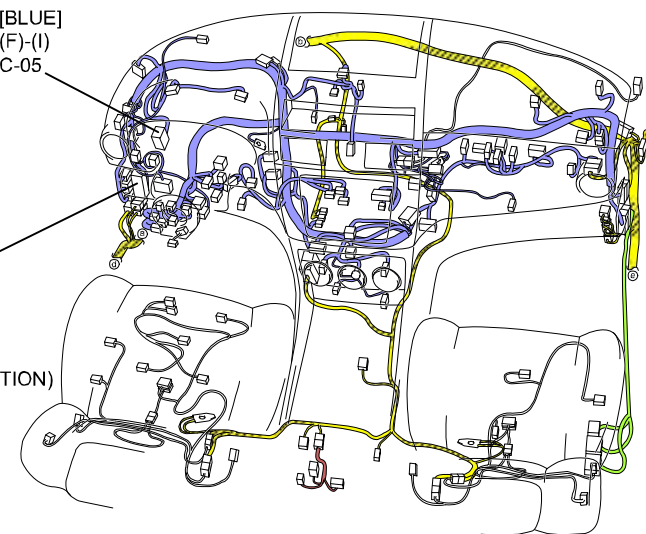

F-02
FUSE BLOCK
(REFER TO 00F SECTION)

- : FRONT HARNESS
- : ENGINE HARNESS
- : INJECTION HARNESS
- : REAR HARNESS
- : REAR NO.5 HARNESS
- : INSTRUMENT PANEL HARNESS
- : FLOOR HARNESS
- : INTERIOR LIGHT NO.2 HARNESS

C-05

FRONT HARNESS-INSTRUMENT PANEL HARNESS

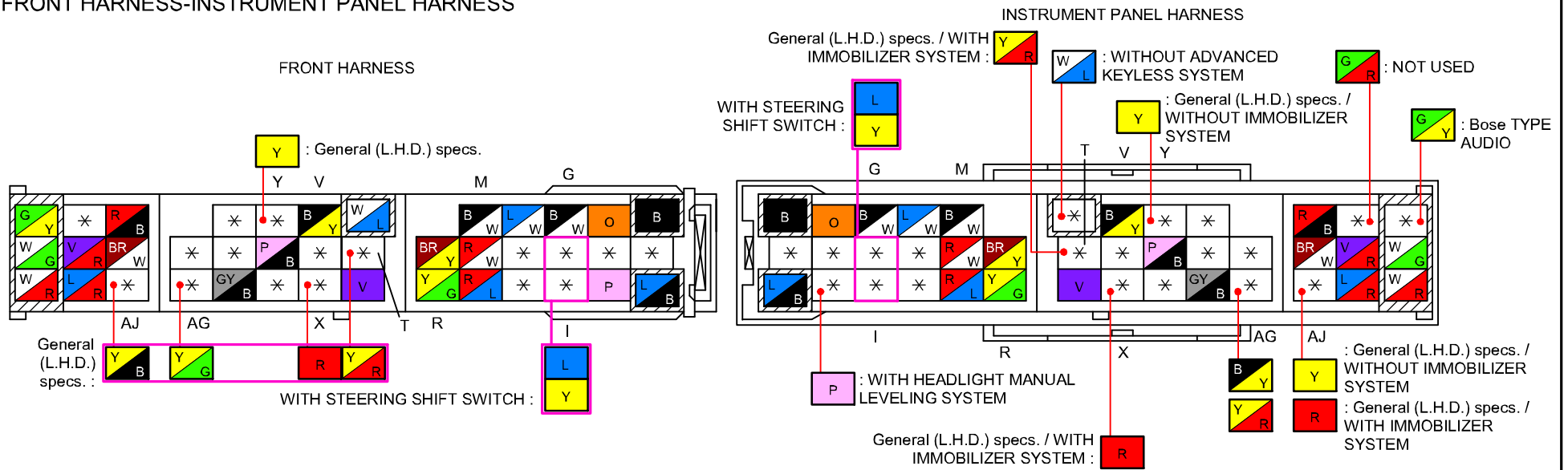

BCM (BODY CONTROL MODULE)

0940-b

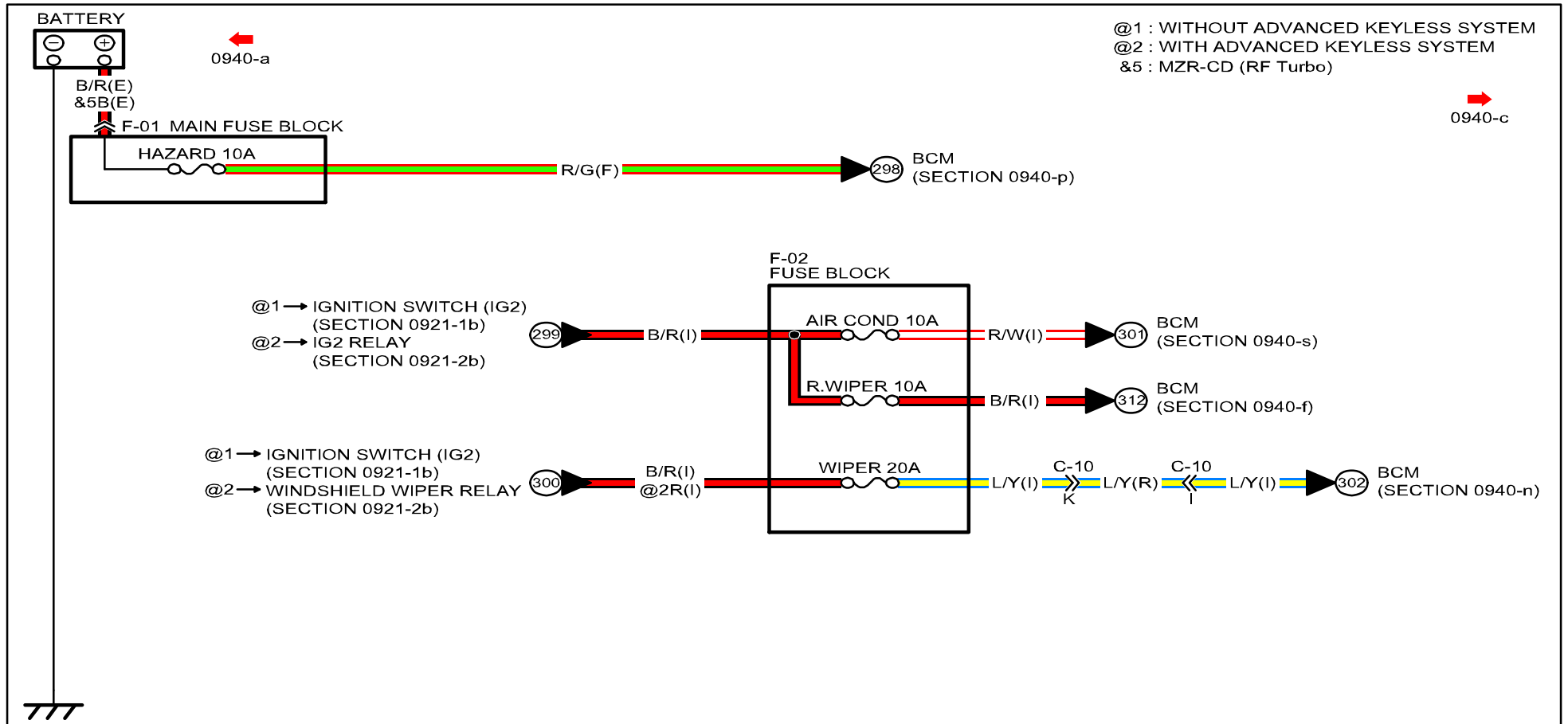

0940-c

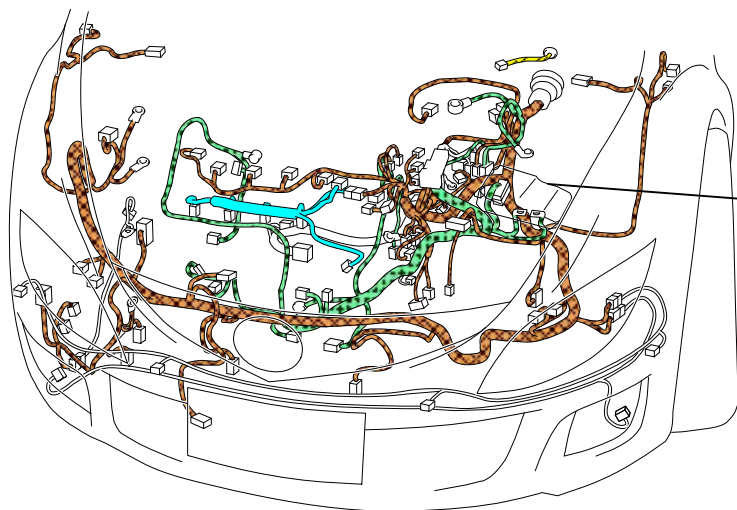

F-01
MAIN FUSE BLOCK
(REFER TO 00F
SECTION)

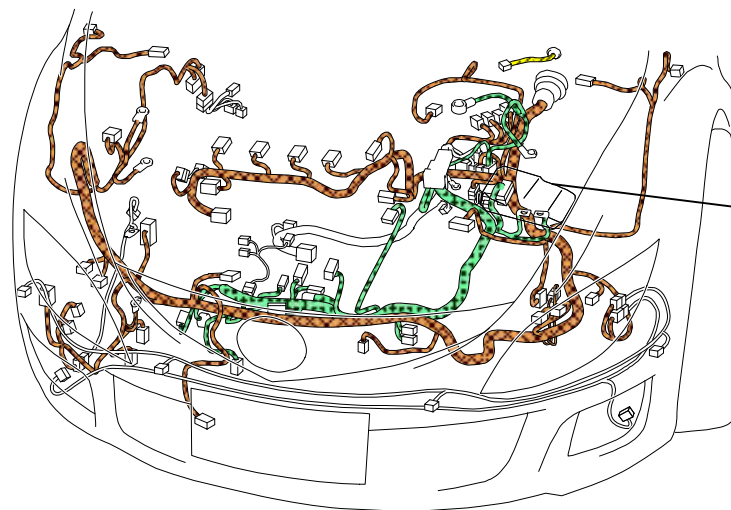

F-01
MAIN FUSE BLOCK
(REFER TO 00F
SECTION)





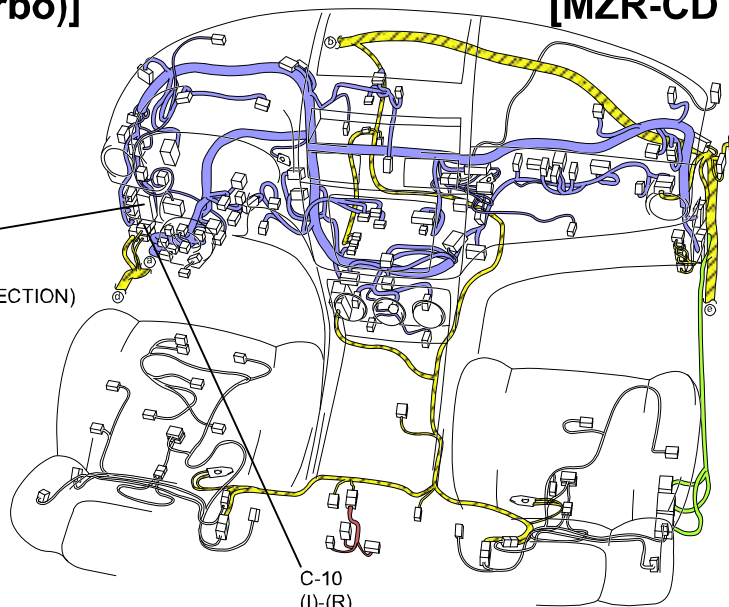

[EXCEPT MZR-CD (RF Turbo)]

[MZR-CD (RF Turbo)]



F-02
FUSE BLOCK
(REFER TO 00F SECTION)

C-10
(L)-(R)

-  : FRONT HARNESS
-  : ENGINE HARNESS
-  : INJECTION HARNESS
-  : REAR HARNESS
-  : REAR NO.5 HARNESS
-  : INSTRUMENT PANEL HARNESS
-  : FLOOR HARNESS

C-10

INSTRUMENT PANEL HARNESS-REAR HARNESS

INSTRUMENT PANEL HARNESS

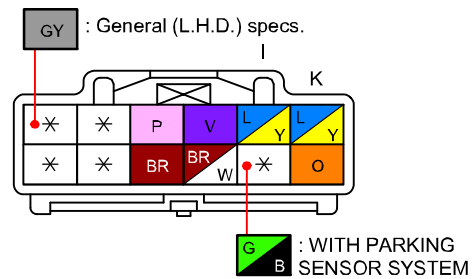

REAR HARNESS

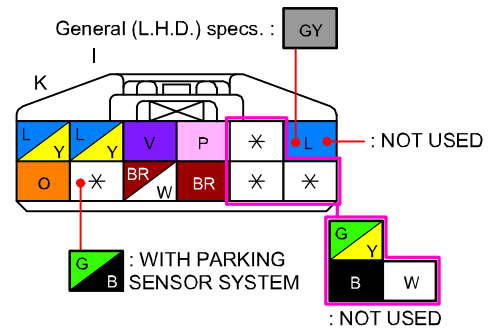

0940-b

@1 : WITHOUT ADVANCED KEYLESS SYSTEM
 @2 : WITH ADVANCED KEYLESS SYSTEM
 #4 : European (L.H.D.) specs.
 #5 : MZR-CD (RF Turbo)

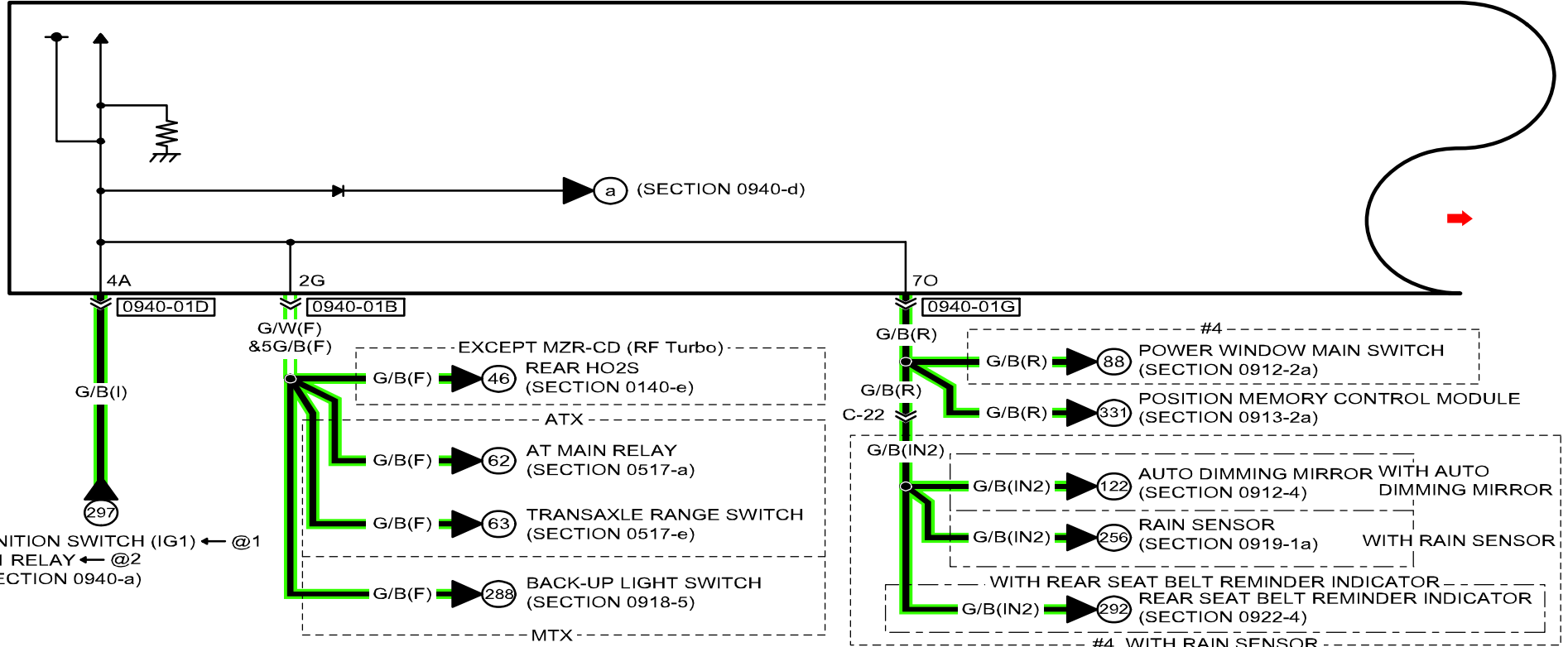

0940-01B
BCM

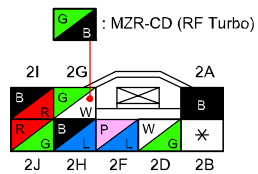

0940-01D
BCM

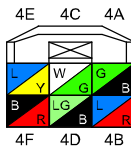

0940-01G
BCM

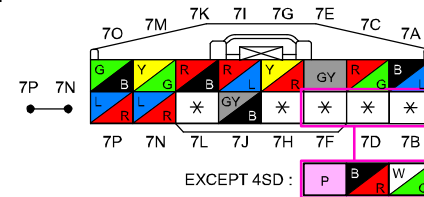

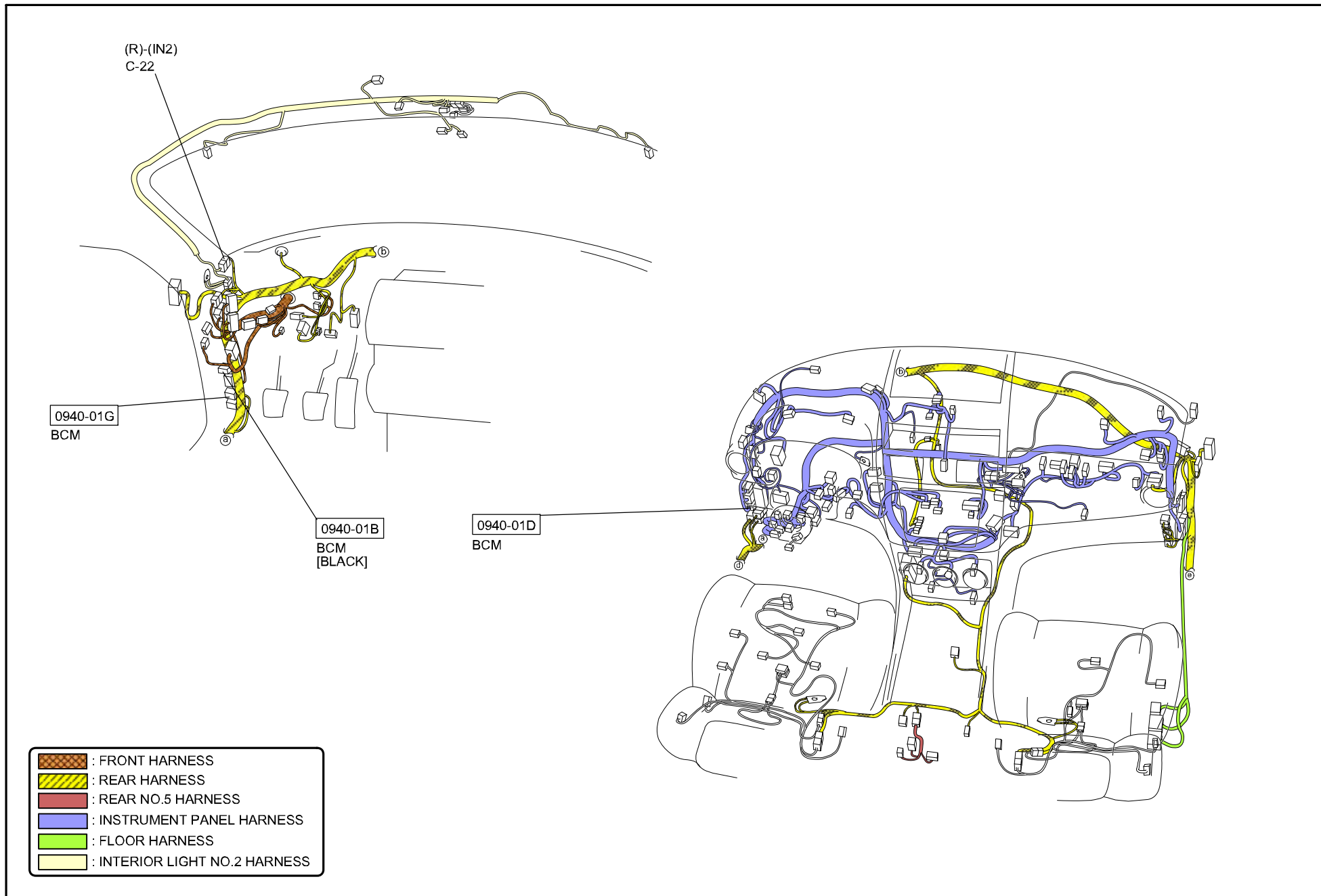

C-22

REAR HARNESS-INTERIOR LIGHT NO.2 HARNESS

REAR HARNESS

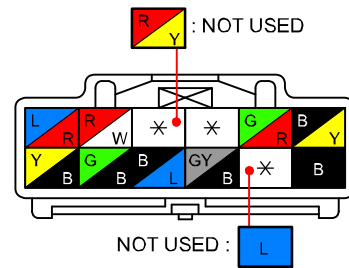

INTERIOR LIGHT NO.2 HARNESS

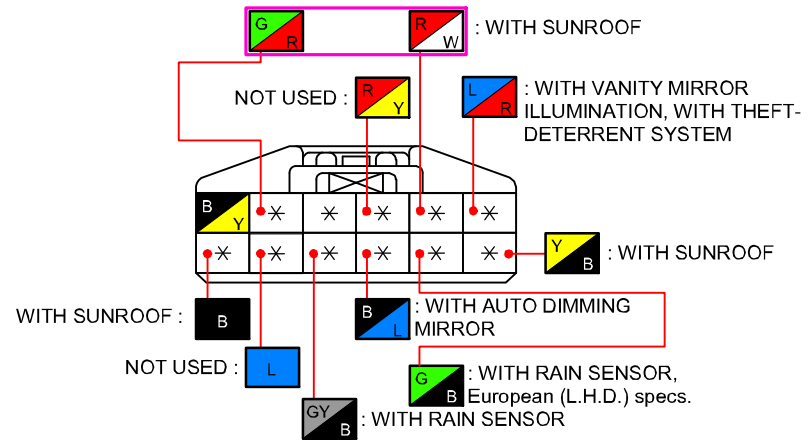

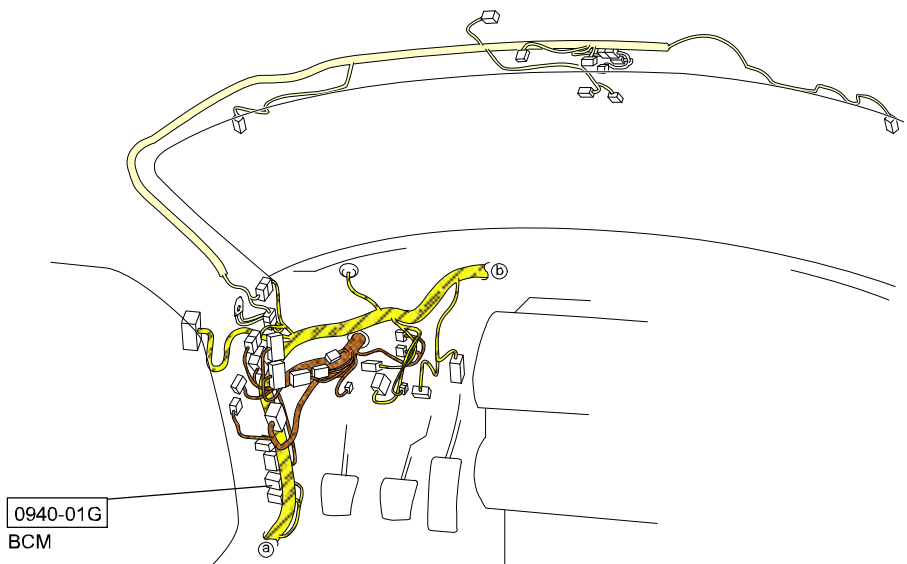





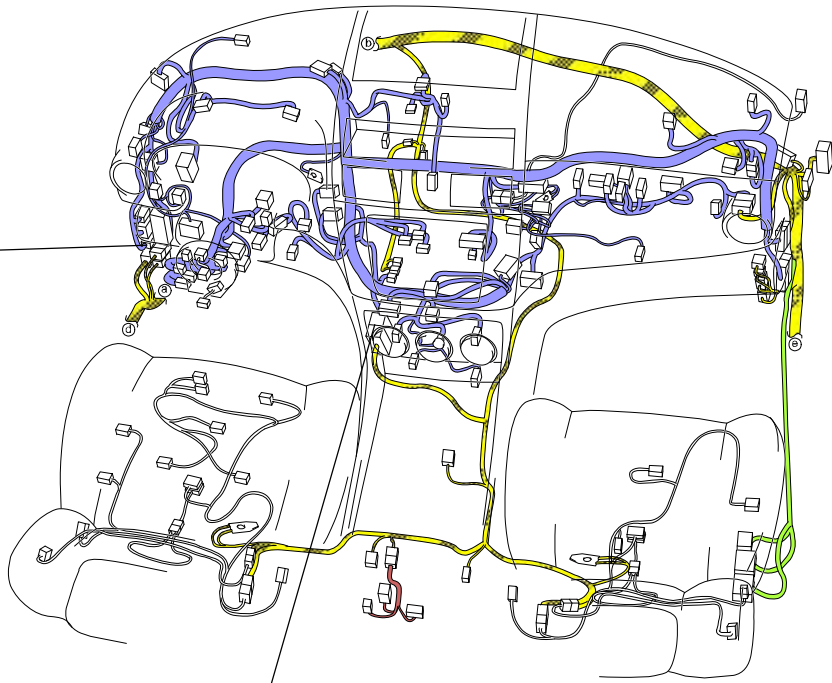

0940-01G
BCM

0940-01D
BCM



C-12
(I)-(R)
[GRAY]

-  : FRONT HARNESS
-  : REAR HARNESS
-  : REAR NO.5 HARNESS
-  : INSTRUMENT PANEL HARNESS
-  : FLOOR HARNESS
-  : INTERIOR LIGHT NO.2 HARNESS

@1 : WITHOUT ADVANCED KEYLESS SYSTEM
 @2 : WITH ADVANCED KEYLESS SYSTEM

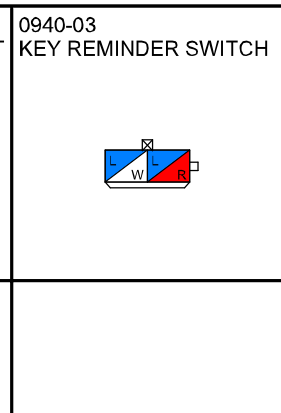
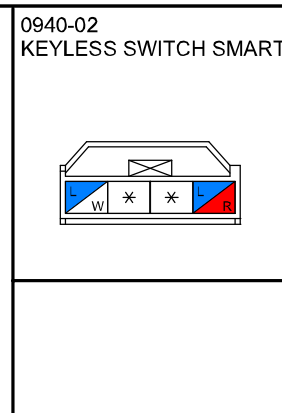
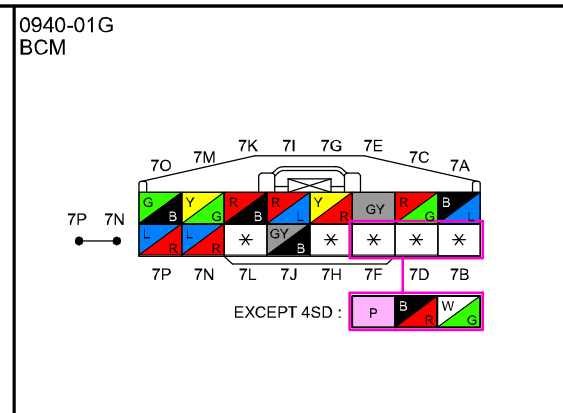
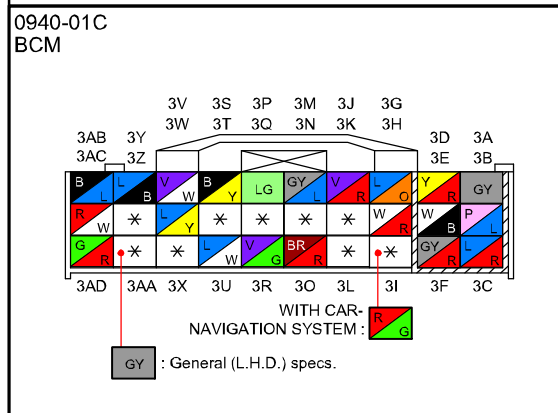
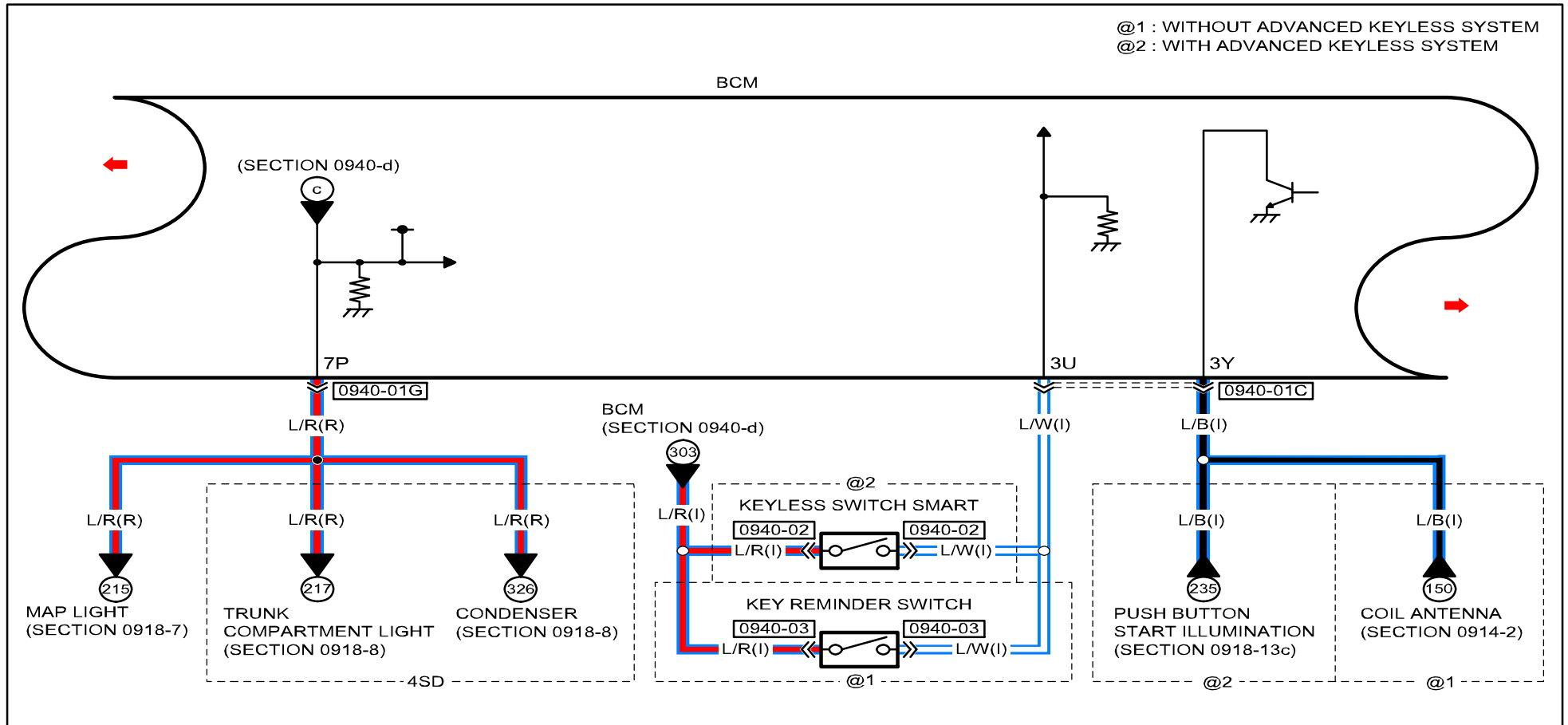

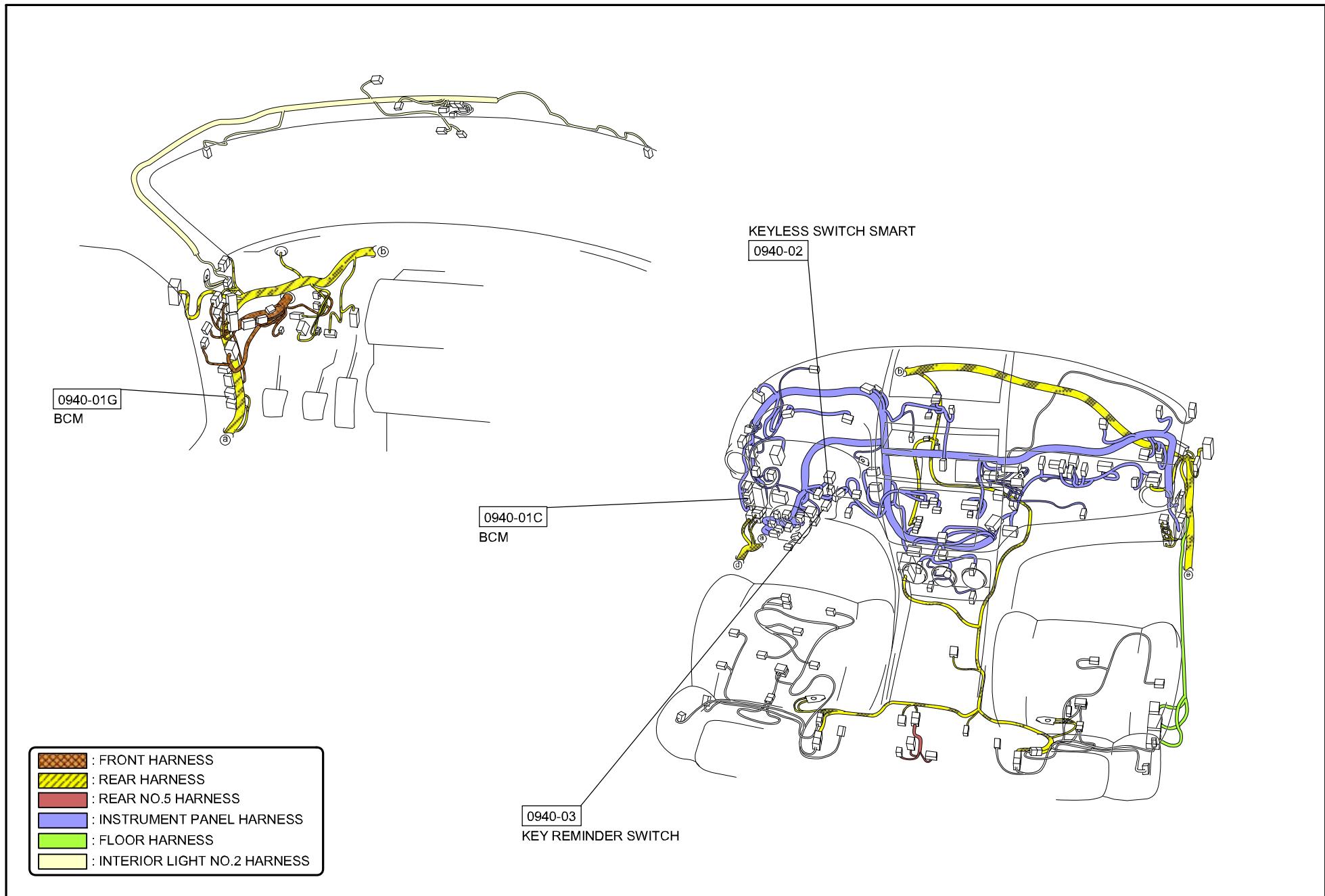

@1 : WITHOUT ADVANCED KEYLESS SYSTEM
 @2 : WITH ADVANCED KEYLESS SYSTEM

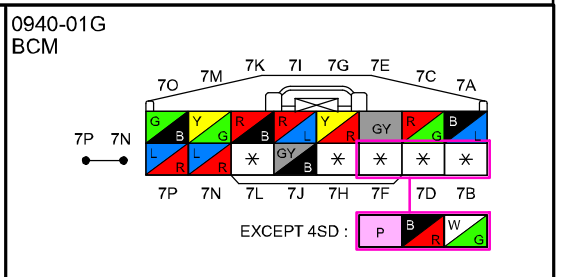
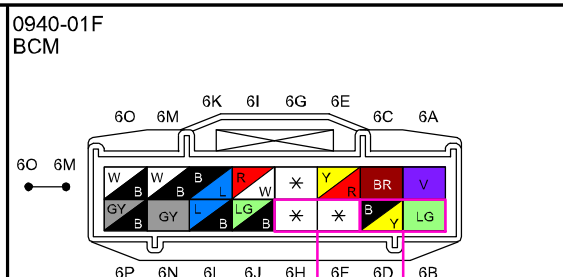
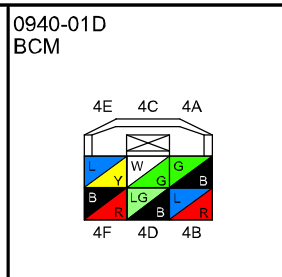
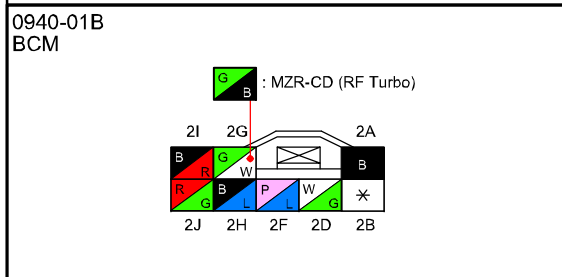
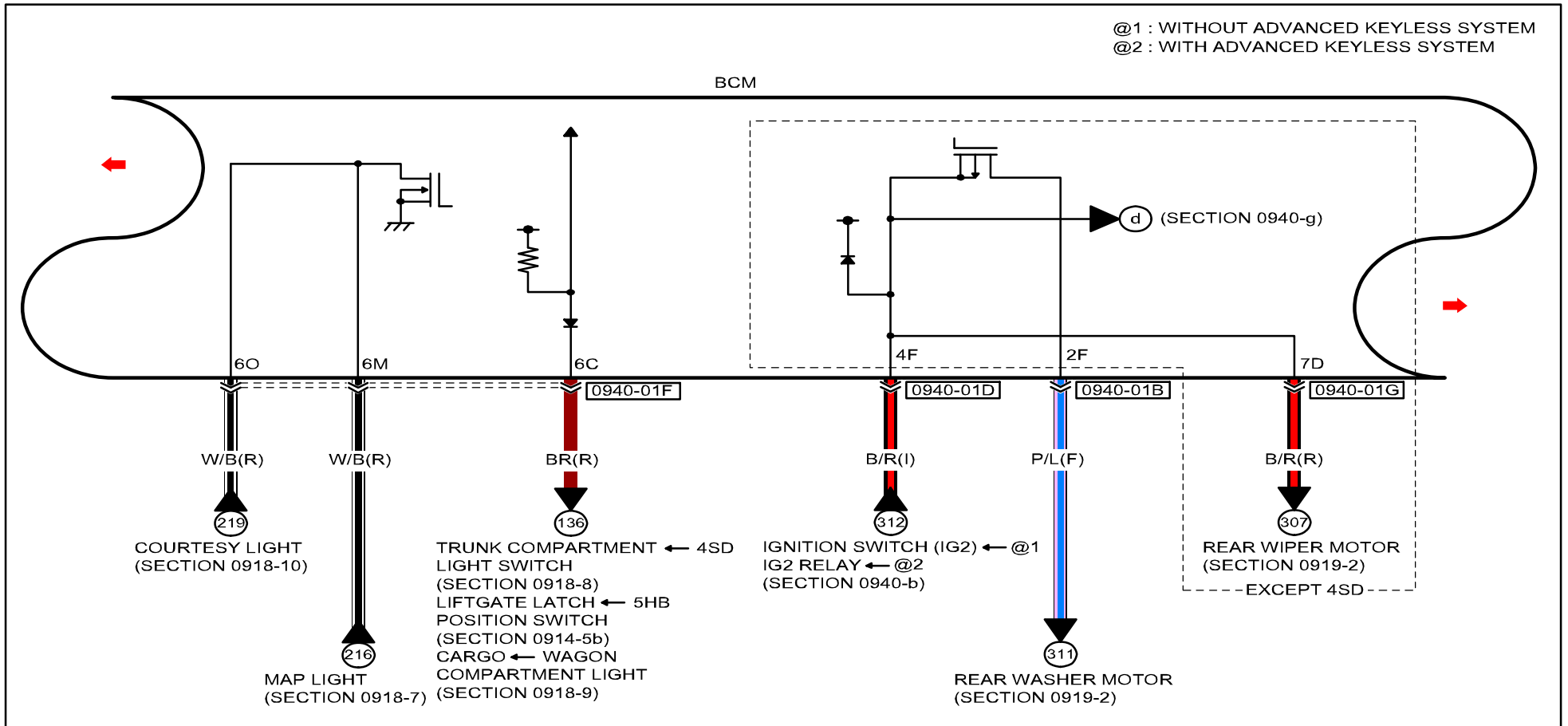





[BLACK]
BCM
0940-01B

0940-01G
BCM

0940-01D
BCM

0940-01F
BCM
[BLACK]

-  : FRONT HARNESS
-  : REAR HARNESS
-  : REAR NO.5 HARNESS
-  : INSTRUMENT PANEL HARNESS
-  : FLOOR HARNESS
-  : INTERIOR LIGHT NO.2 HARNESS

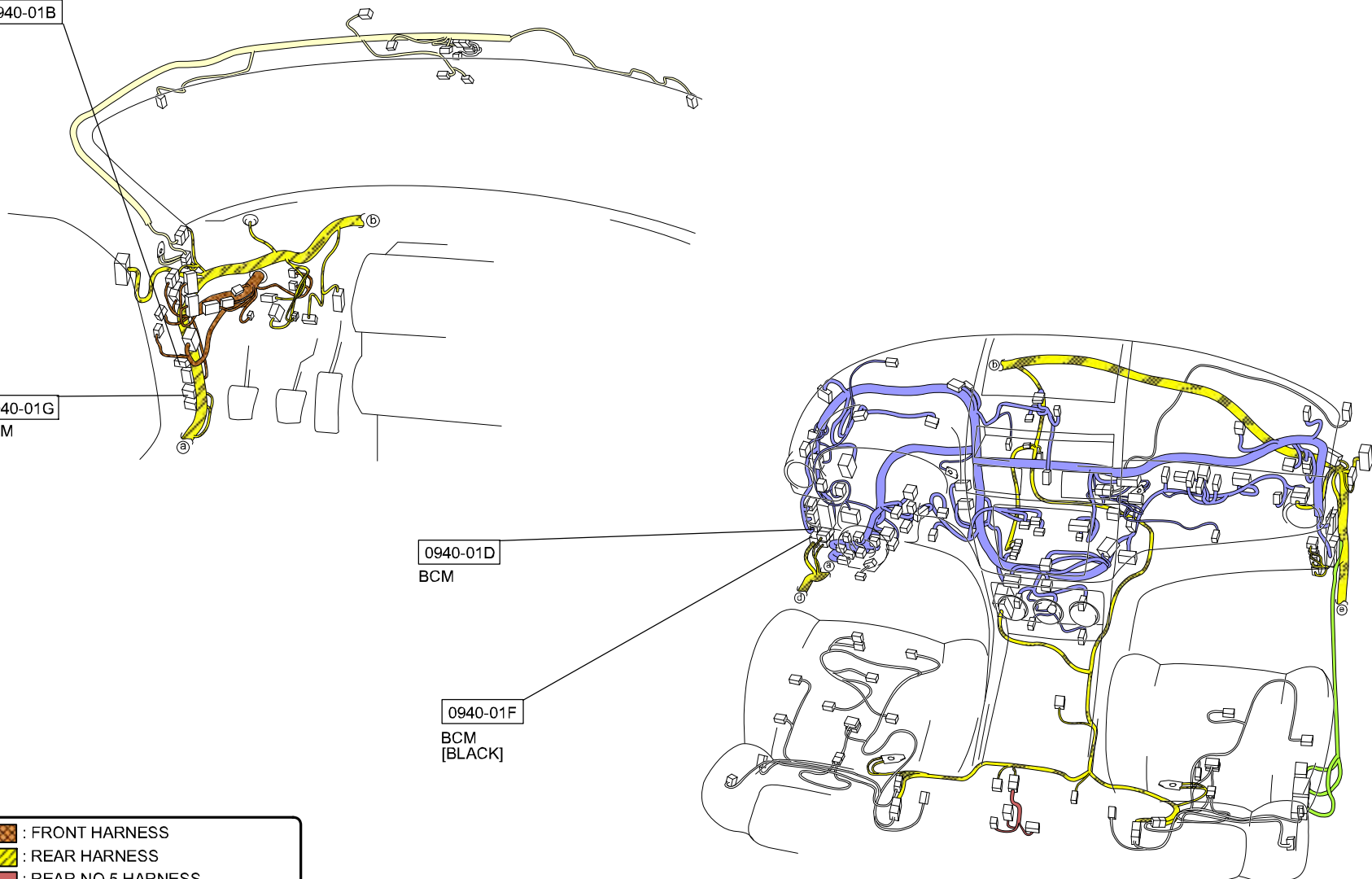

@2 : WITH ADVANCED KEYLESS SYSTEM

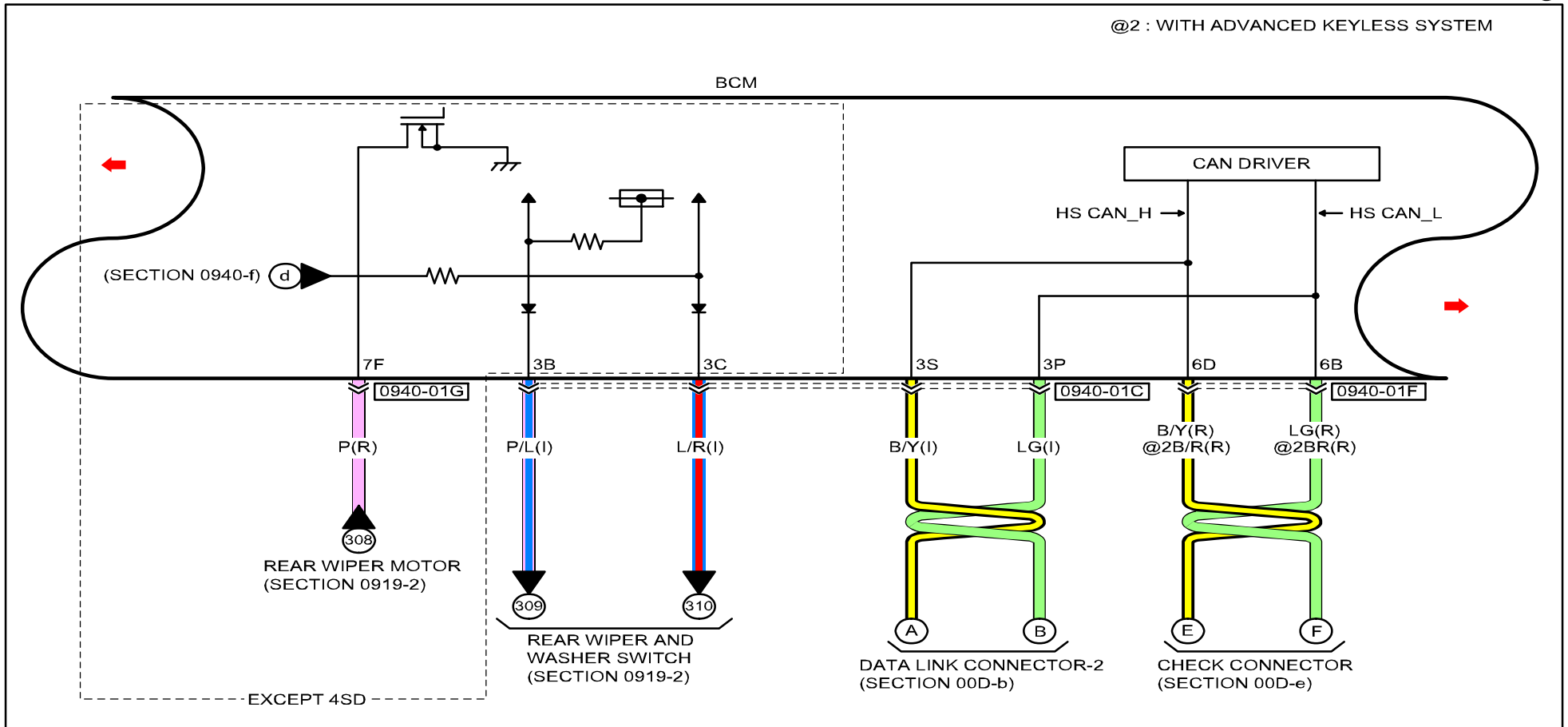

0940-01C
BCM

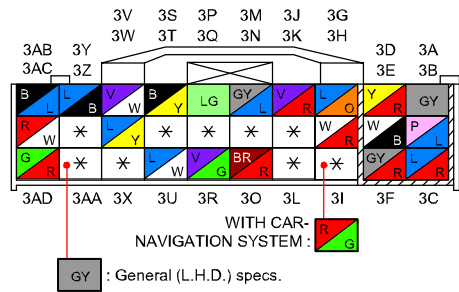



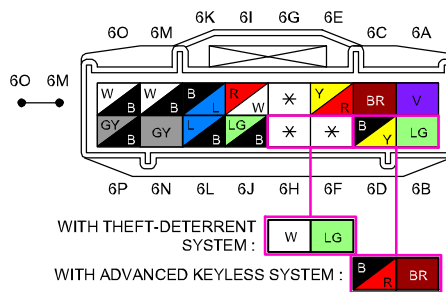

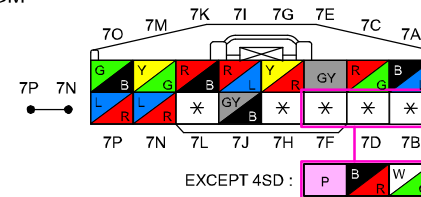

0940-01F
BCM

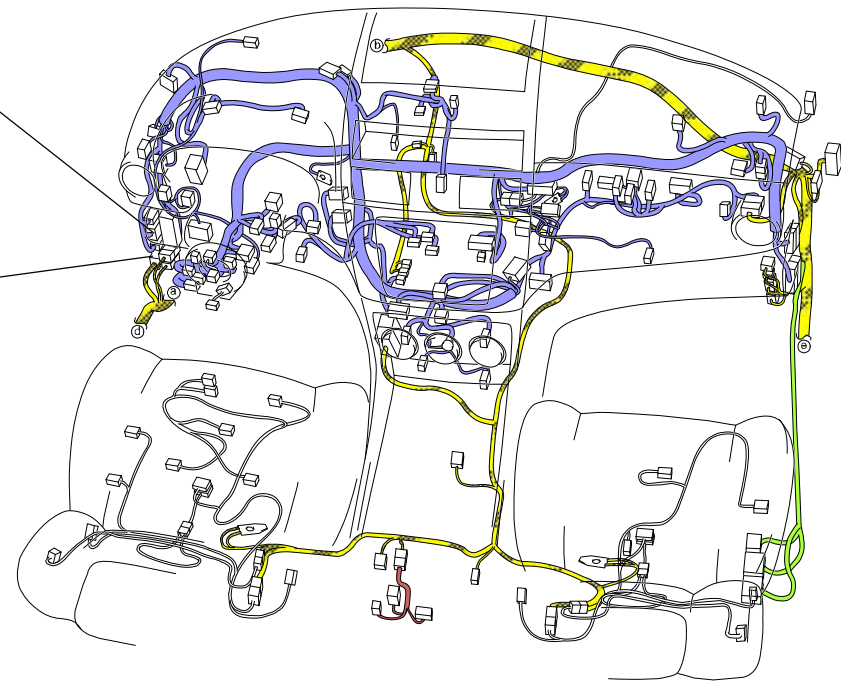
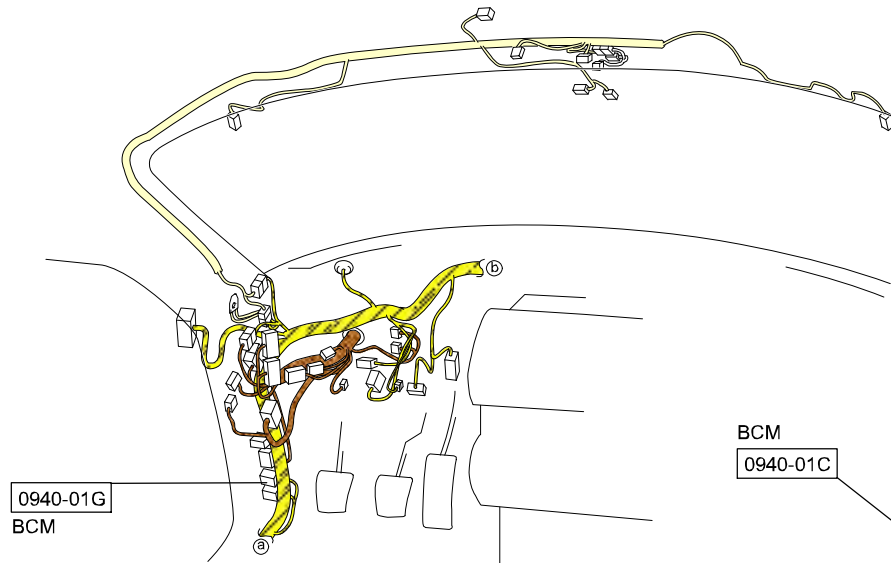

0940-01G
BCM





-  : FRONT HARNESS
-  : REAR HARNESS
-  : REAR NO.5 HARNESS
-  : INSTRUMENT PANEL HARNESS
-  : FLOOR HARNESS
-  : INTERIOR LIGHT NO.2 HARNESS

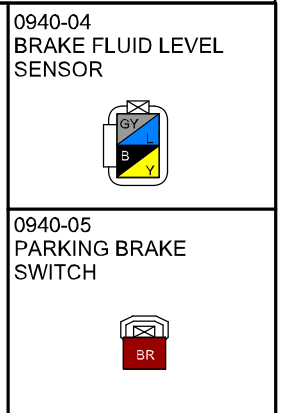
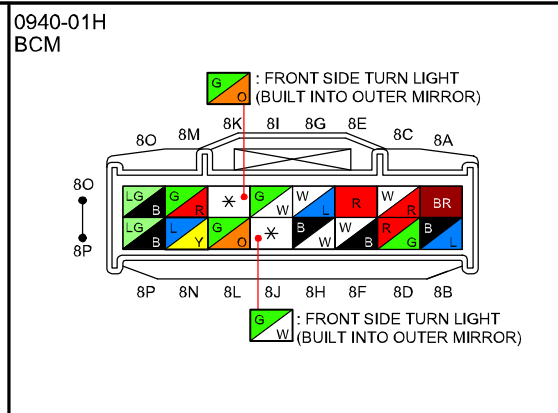
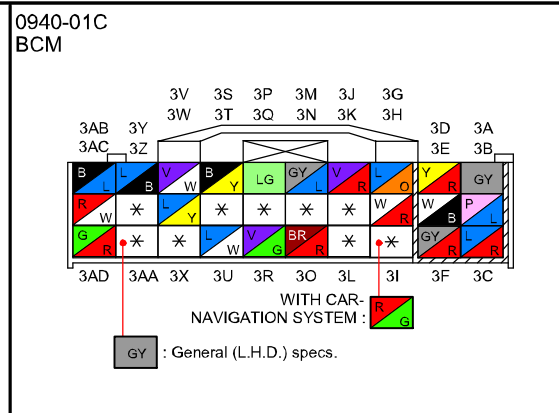
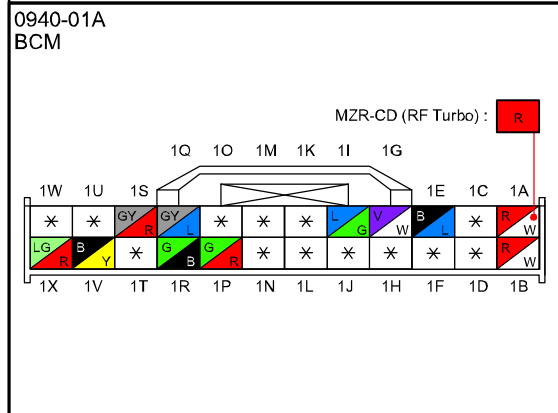
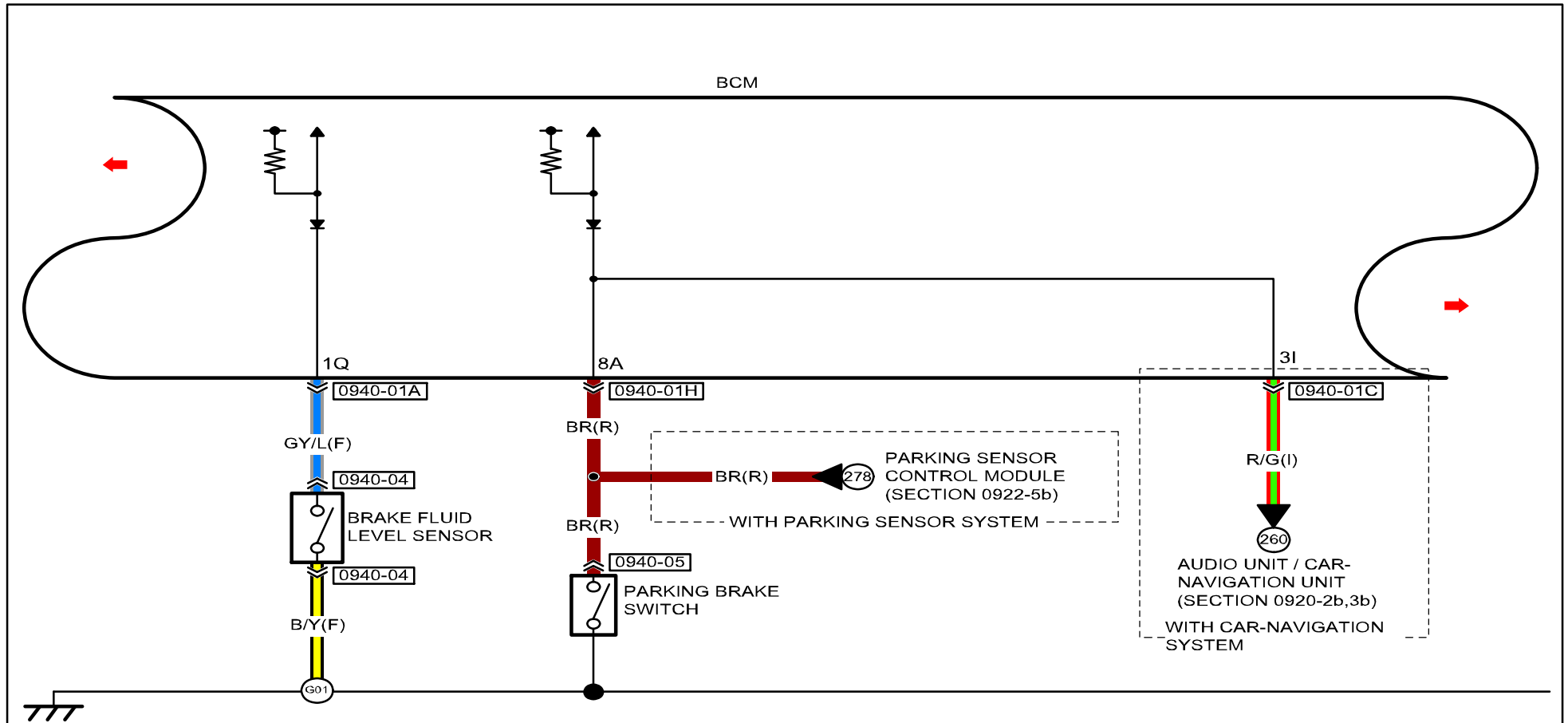

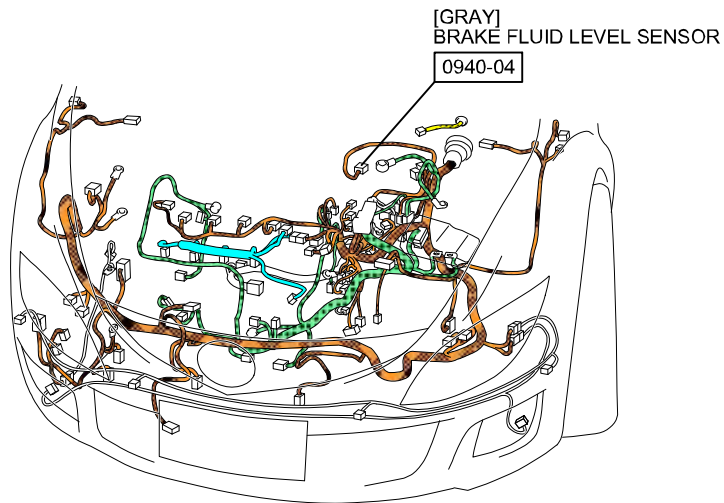



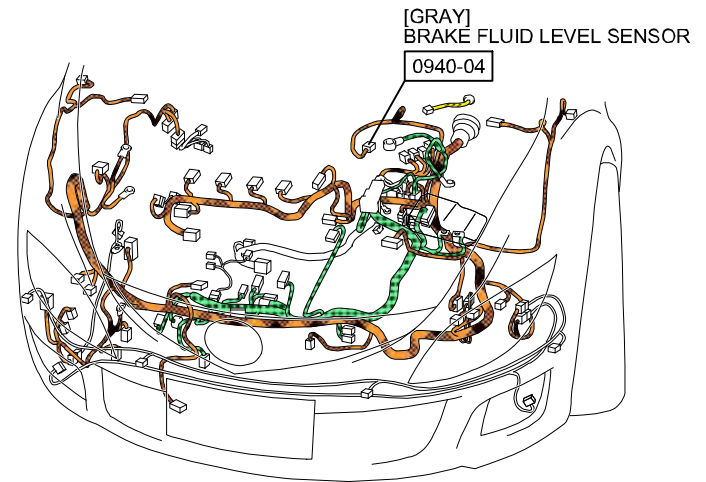



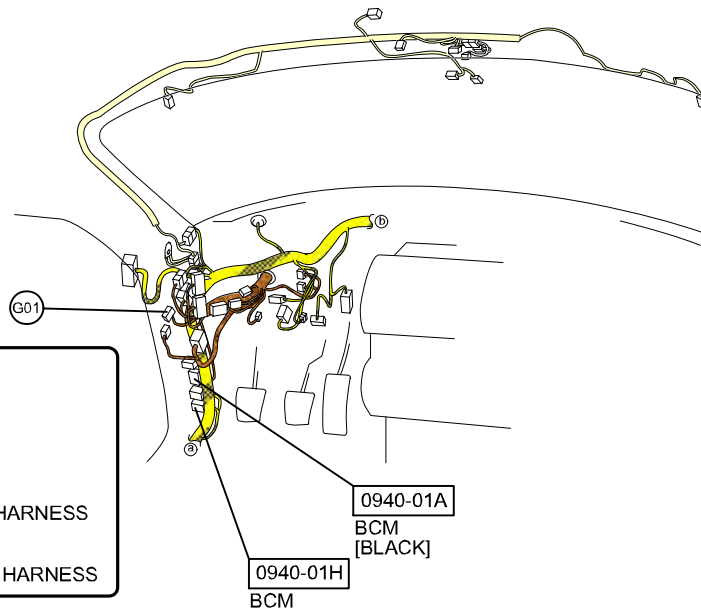

[EXCEPT MZR-CD (RF Turbo)]



[MZR-CD (RF Turbo)]



-  : FRONT HARNESS
-  : ENGINE HARNESS
-  : INJECTION HARNESS
-  : REAR HARNESS
-  : REAR NO.5 HARNESS
-  : INSTRUMENT PANEL HARNESS
-  : FLOOR HARNESS
-  : INTERIOR LIGHT NO.2 HARNESS

0940-01C
BCM

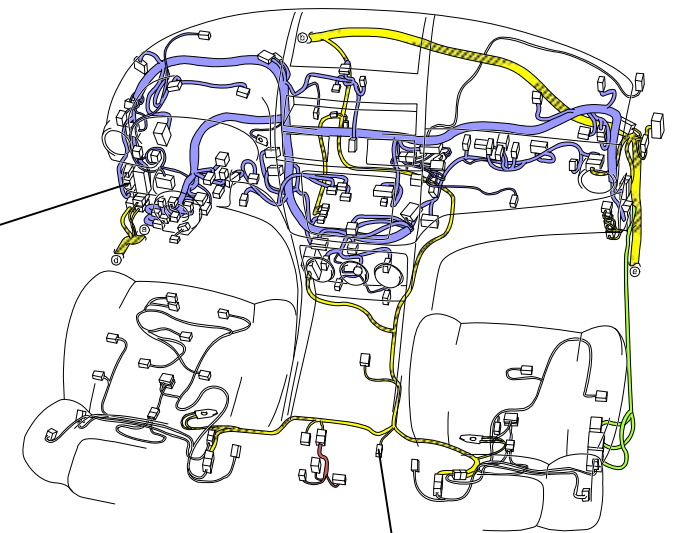

0940-05
PARKING BRAKE SWITCH

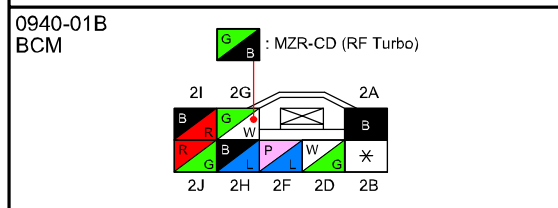
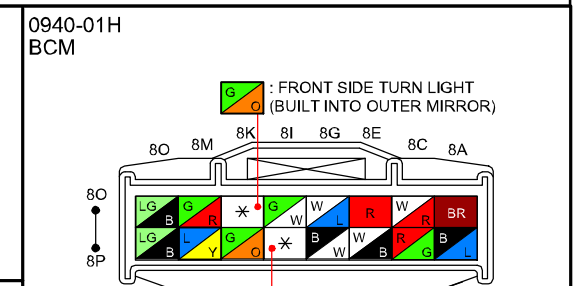
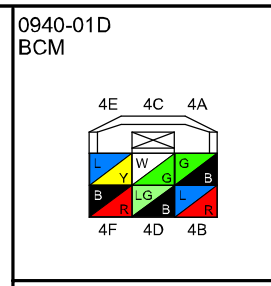
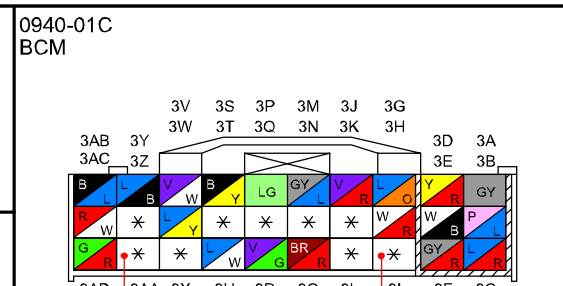
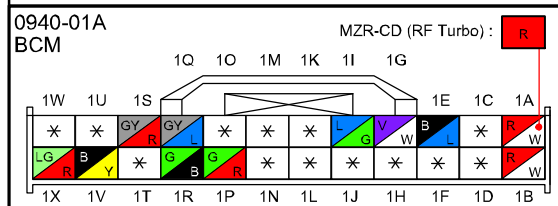
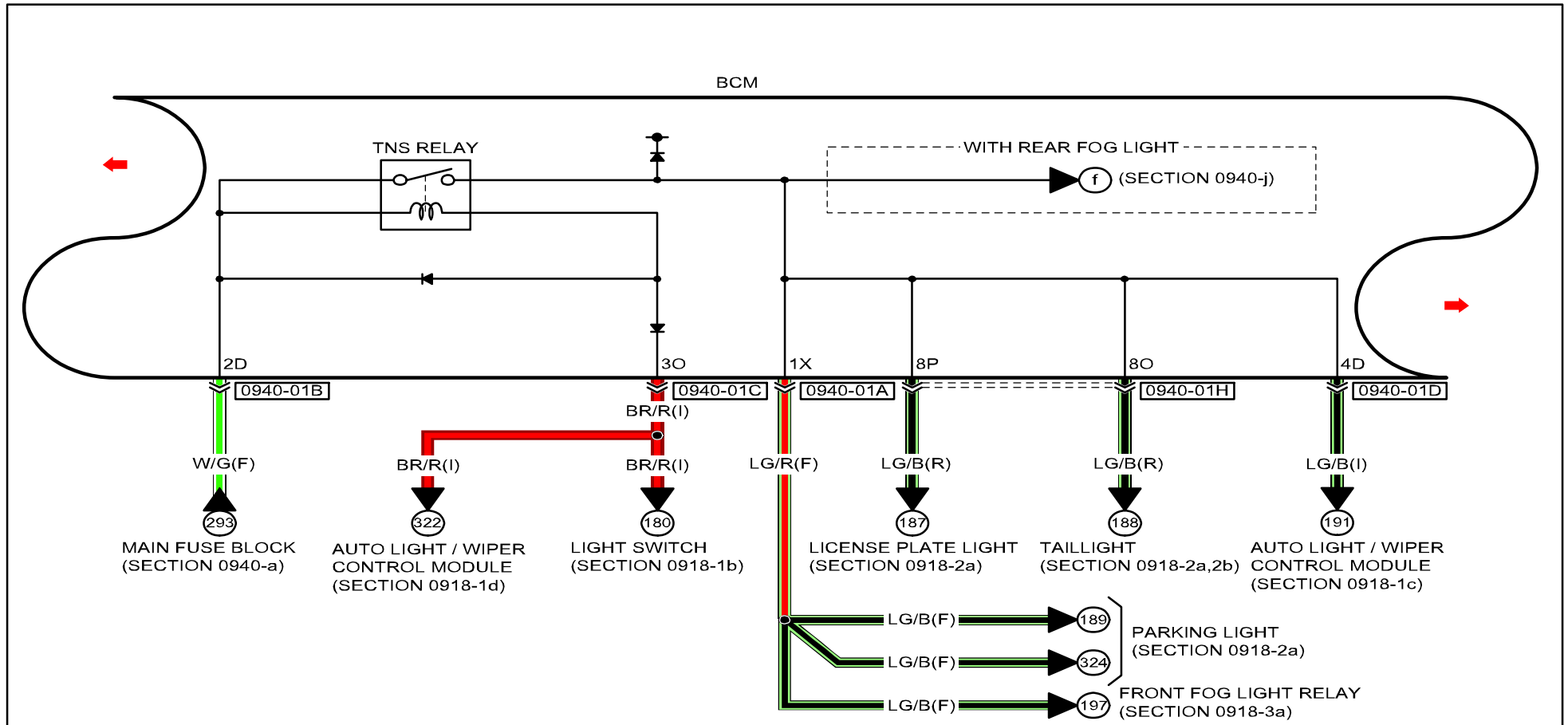

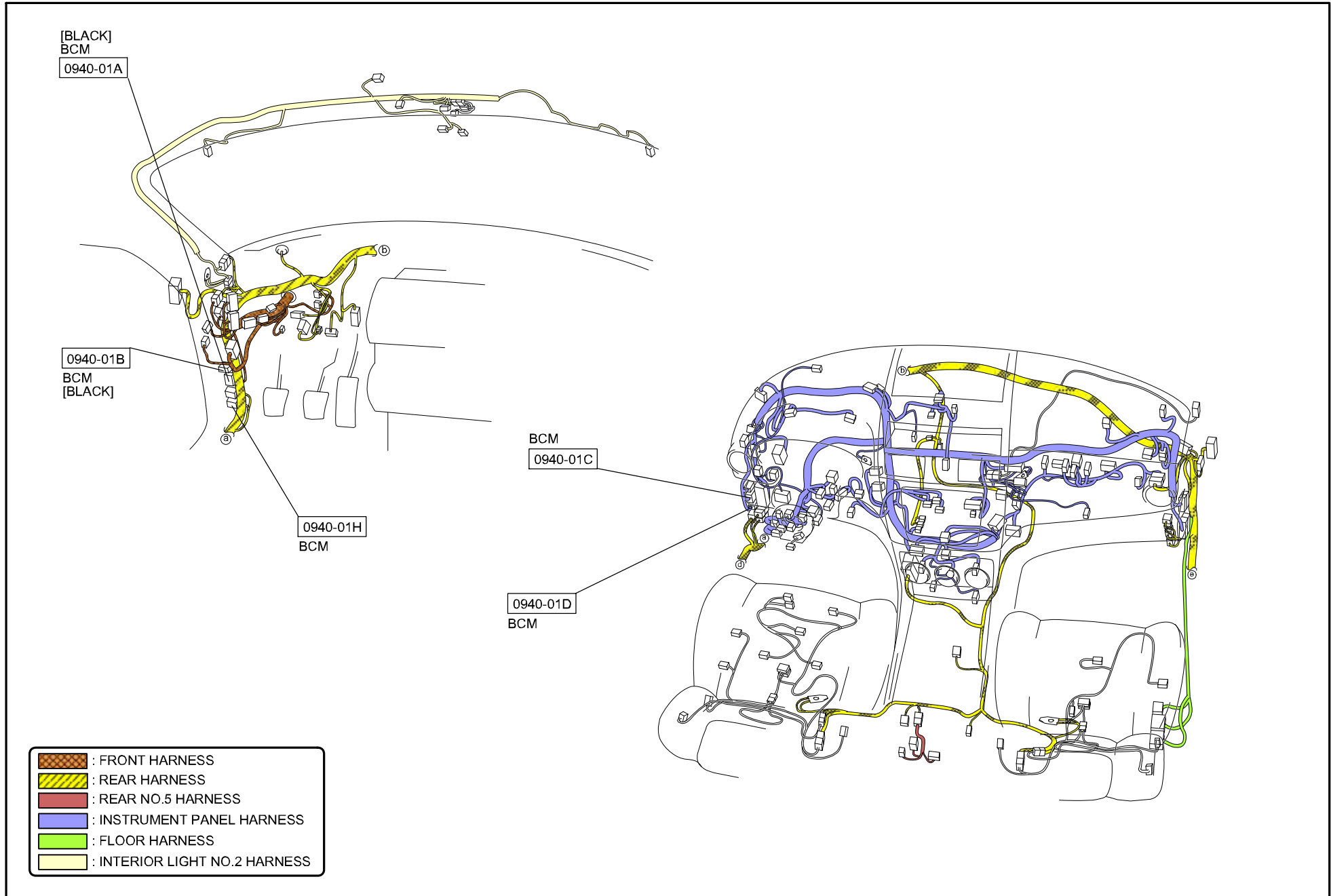

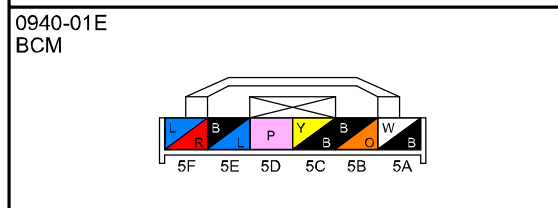
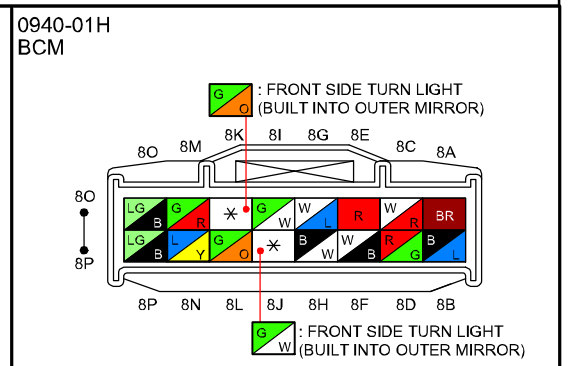
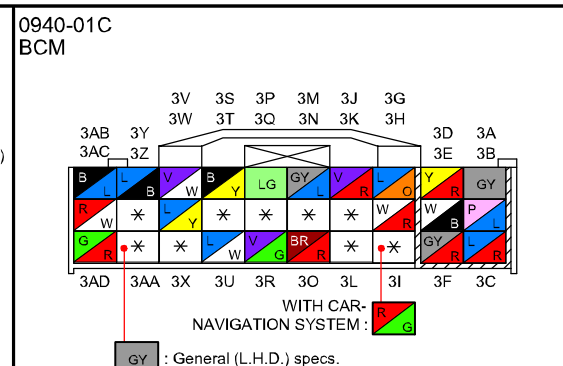
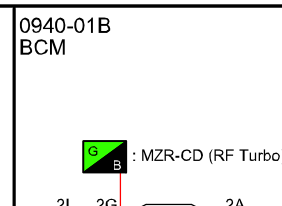
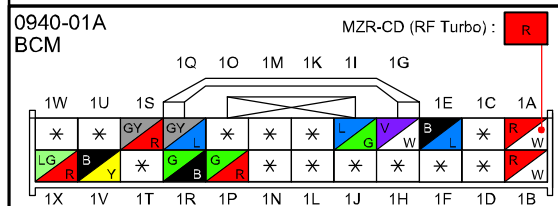
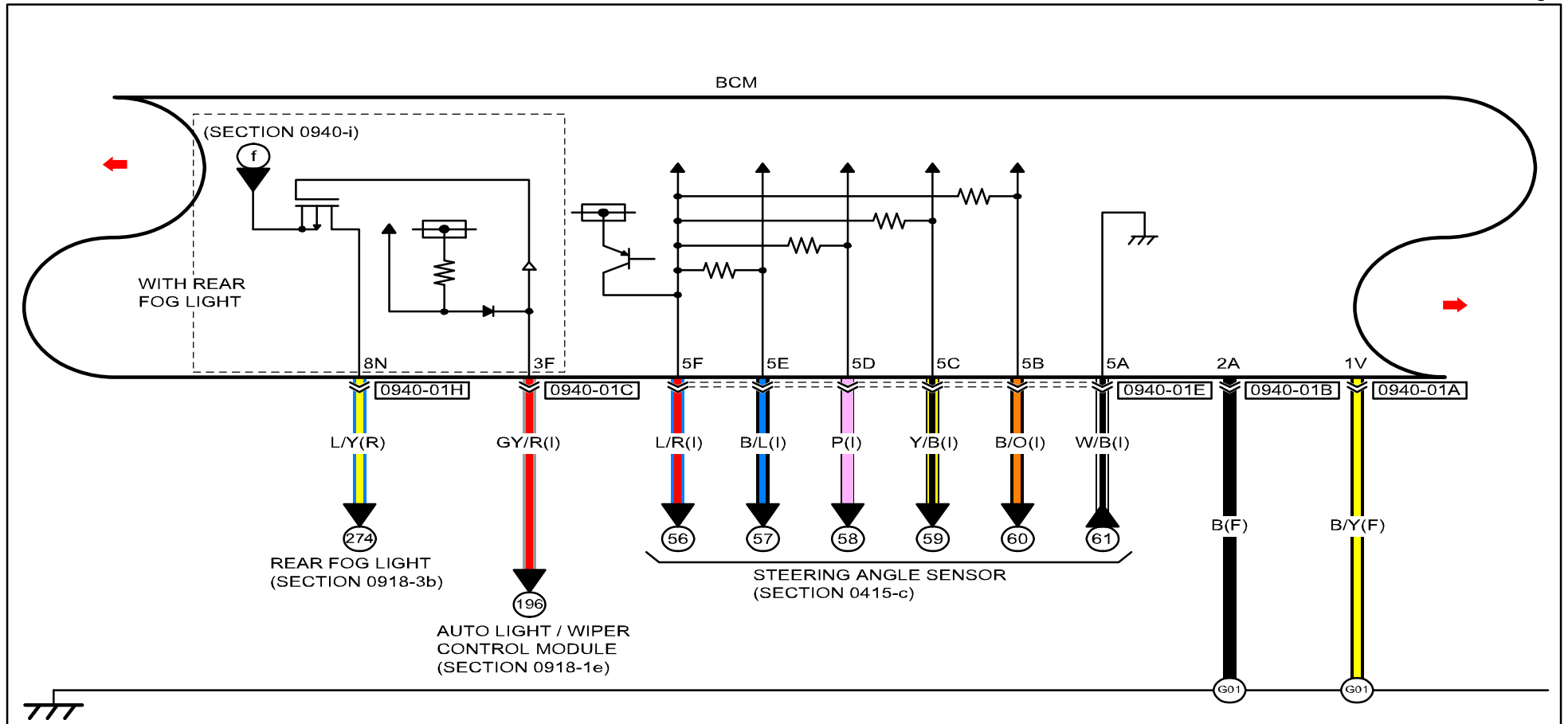

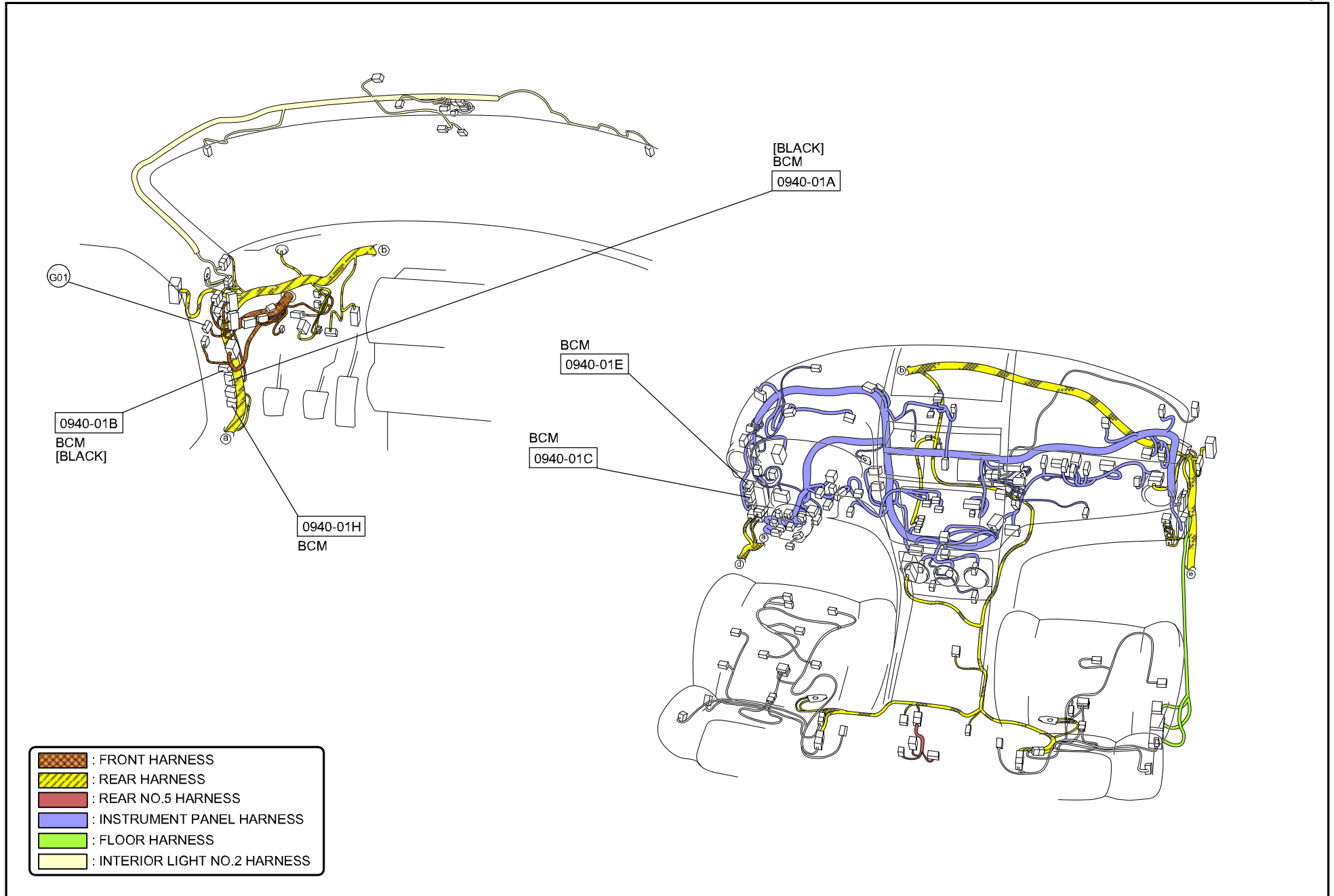

&2 : WITH THEFT-DETERRENT SYSTEM

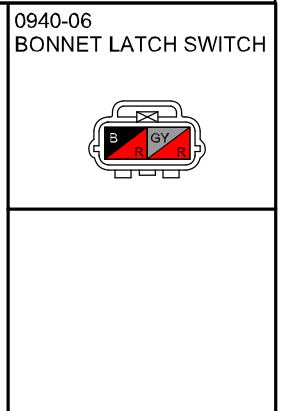
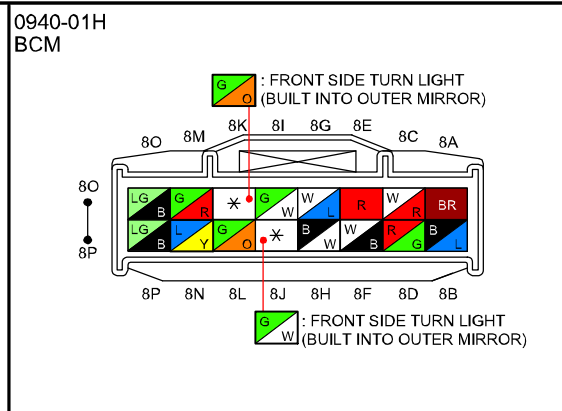
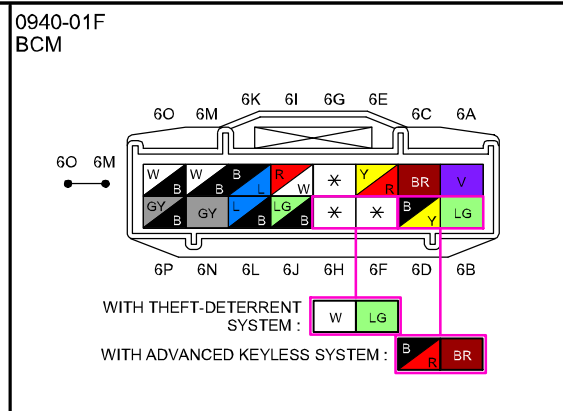
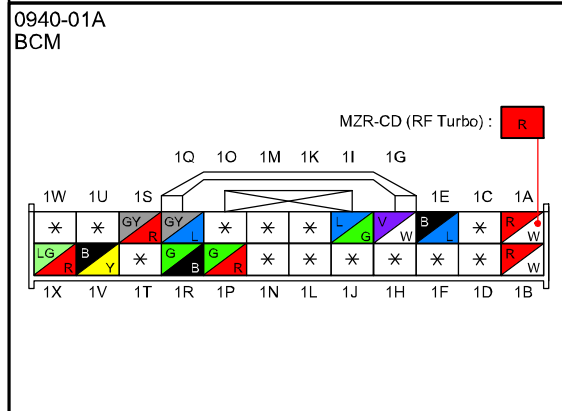
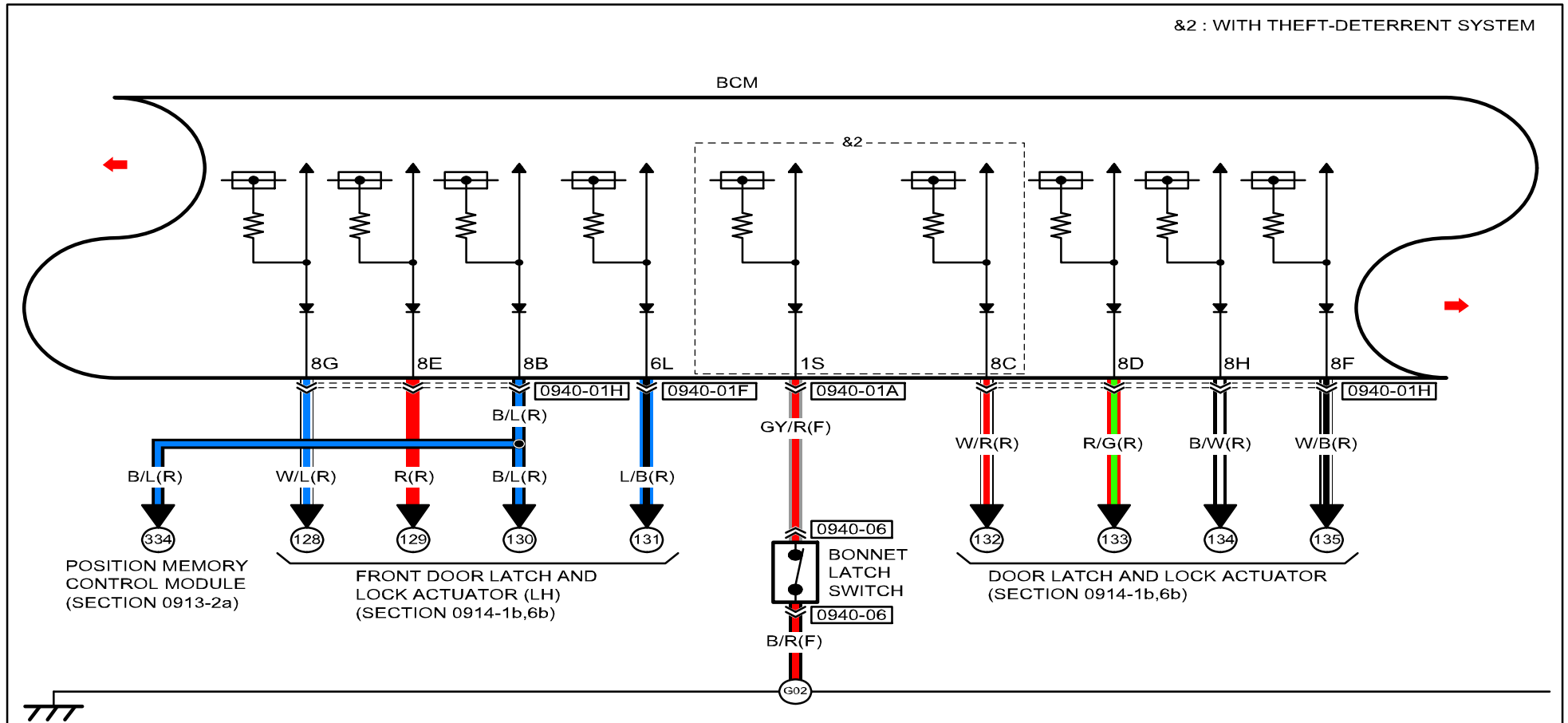

[EXCEPT MZR-CD (RF Turbo)]

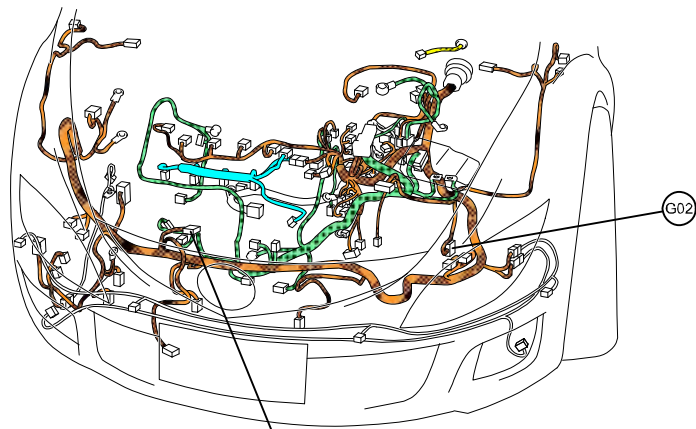

0940-06
BONNET LATCH SWITCH
[GRAY]

[MZR-CD (RF Turbo)]

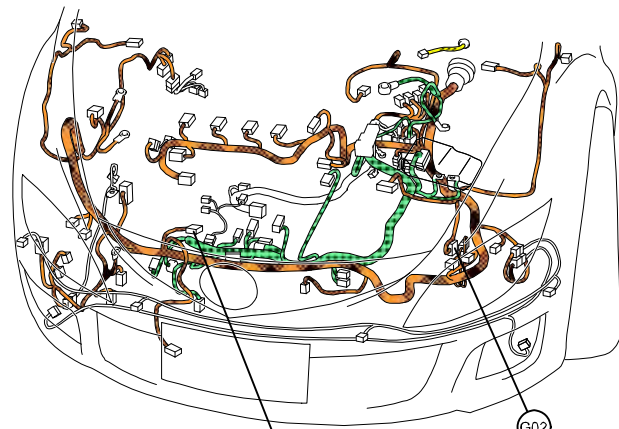



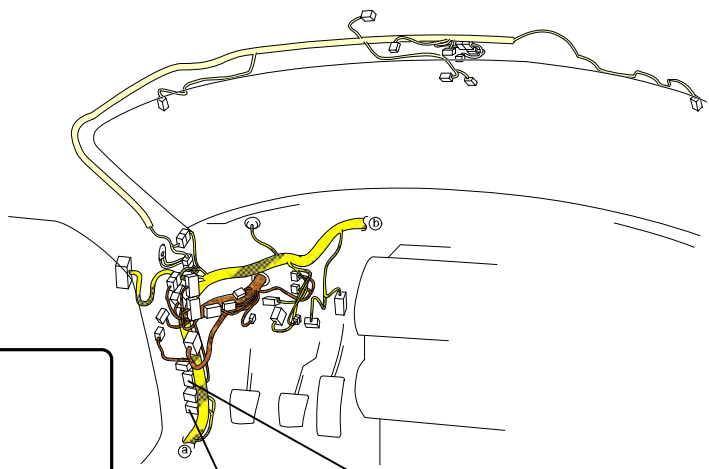



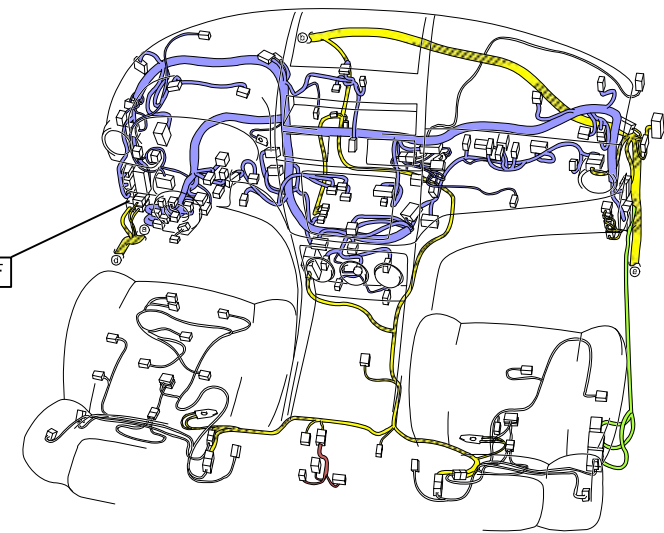

0940-06
BONNET LATCH SWITCH
[GRAY]



0940-01H
BCM



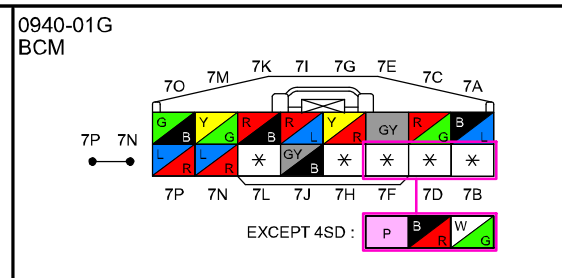
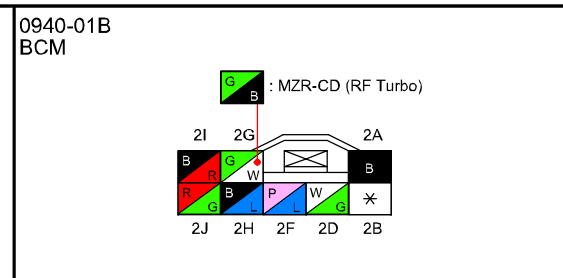
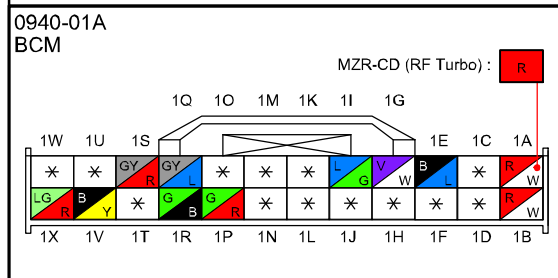
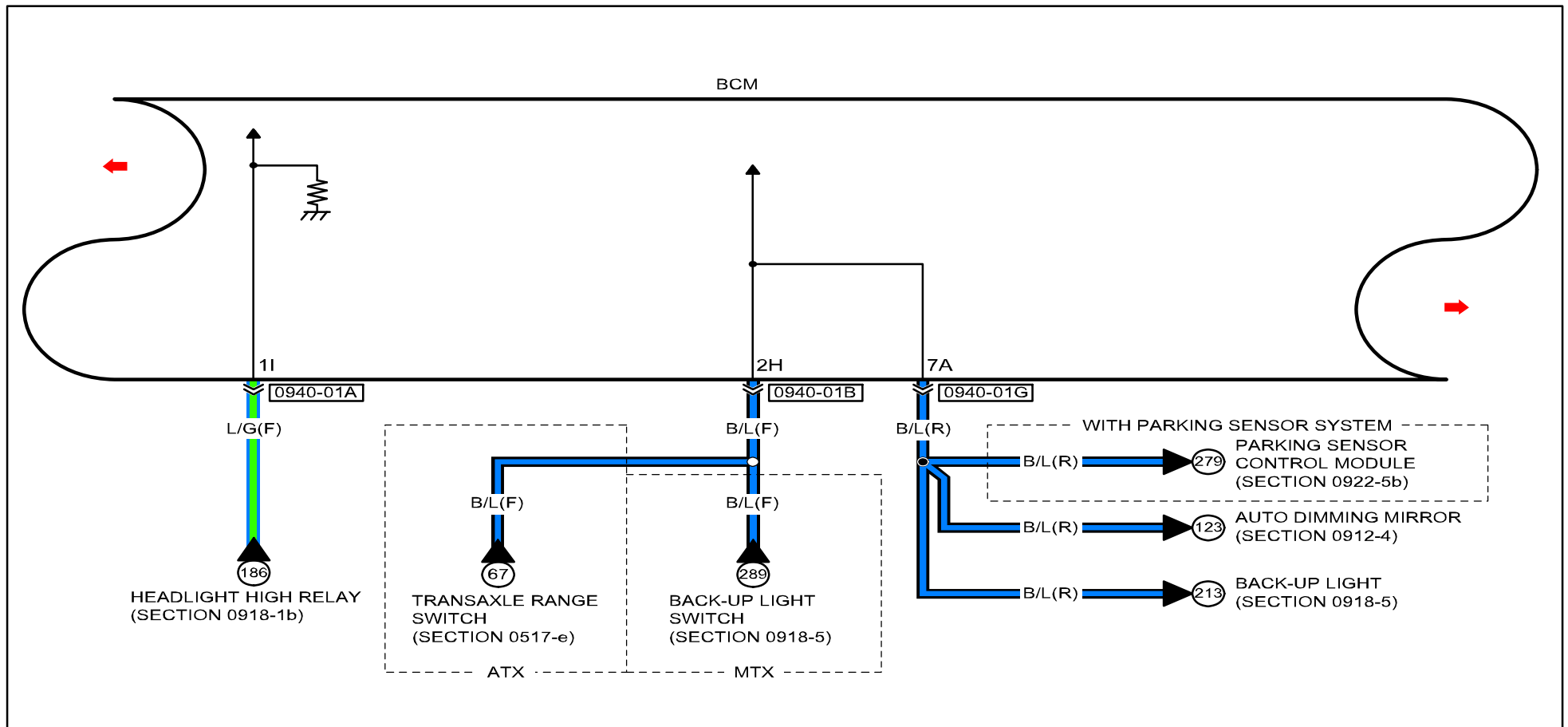

0940-01F
BCM
[BLACK]

-  : FRONT HARNESS
-  : ENGINE HARNESS
-  : INJECTION HARNESS
-  : REAR HARNESS
-  : REAR NO.5 HARNESS
-  : INSTRUMENT PANEL HARNESS
-  : FLOOR HARNESS
-  : INTERIOR LIGHT NO.2 HARNESS





-  : FRONT HARNESS
-  : REAR HARNESS
-  : INTERIOR LIGHT NO.2 HARNESS

@1 : WITHOUT ADVANCED KEYLESS SYSTEM
 @2 : WITH ADVANCED KEYLESS SYSTEM

@3 : WITHOUT DSC
 @4 : WITH DSC
 #4 : European (L.H.D.) specs.

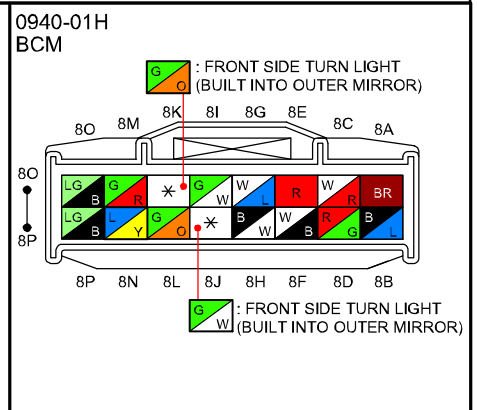
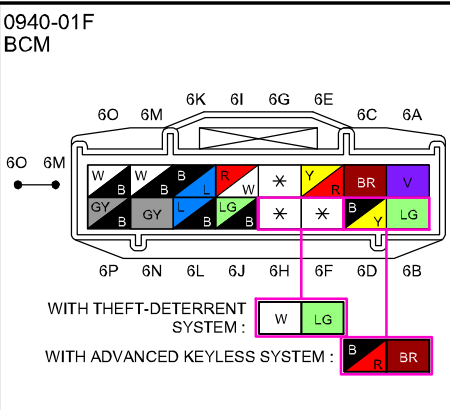
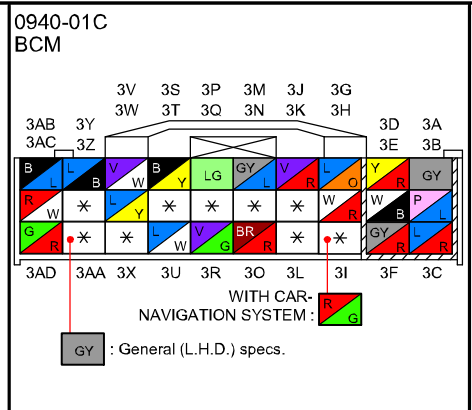
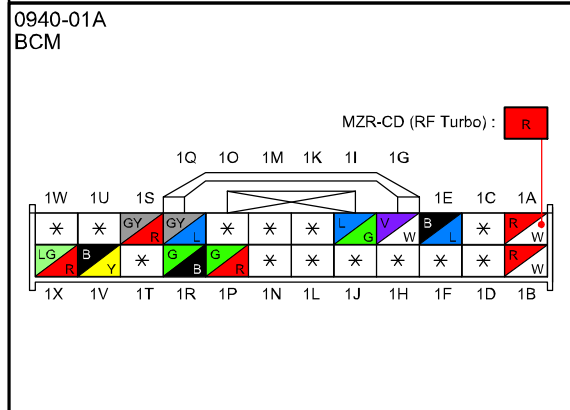
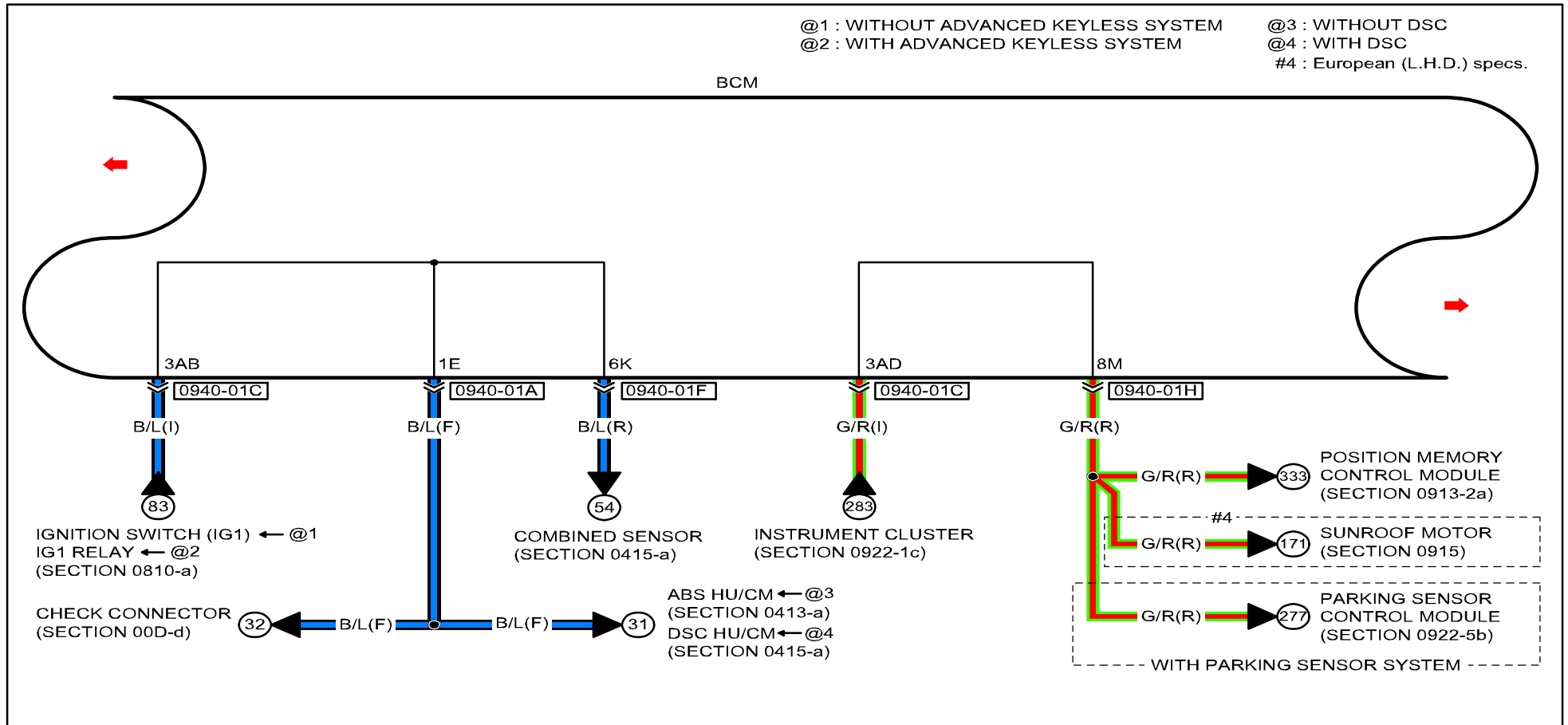

[BLACK]
BCM
0940-01A

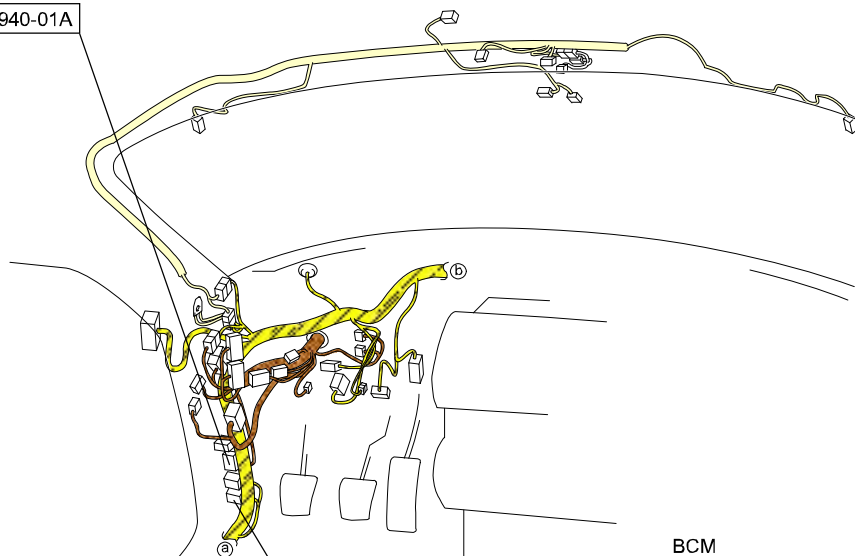

0940-01H
BCM

BCM
0940-01C

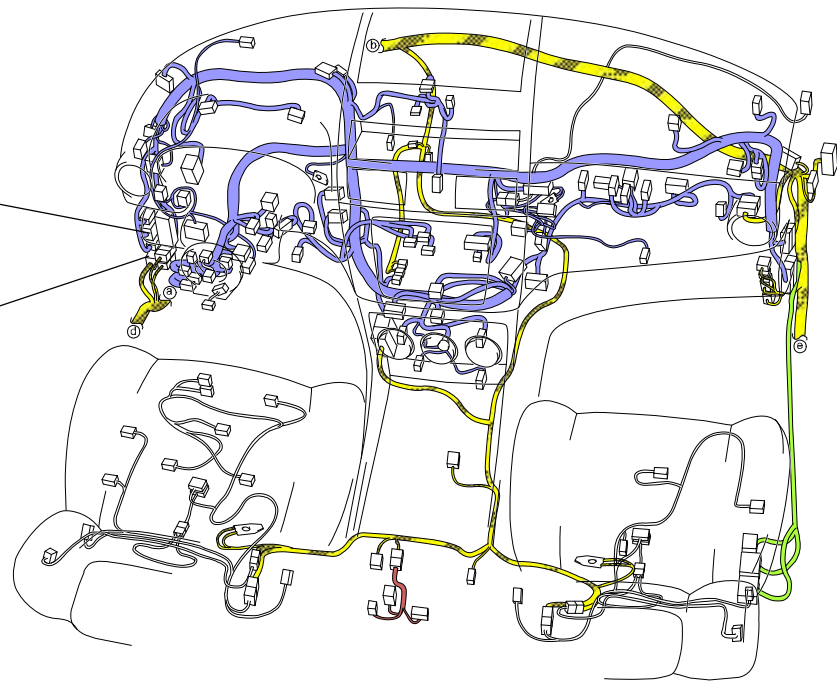

0940-01F
BCM
[BLACK]

- : FRONT HARNESS
- : REAR HARNESS
- : REAR NO.5 HARNESS
- : INSTRUMENT PANEL HARNESS
- : FLOOR HARNESS
- : INTERIOR LIGHT NO.2 HARNESS

@1 : WITHOUT ADVANCED KEYLESS SYSTEM
 @2 : WITH ADVANCED KEYLESS SYSTEM
 &4 : General (L.H.D.) specs.
 #4 : European (L.H.D.) specs.

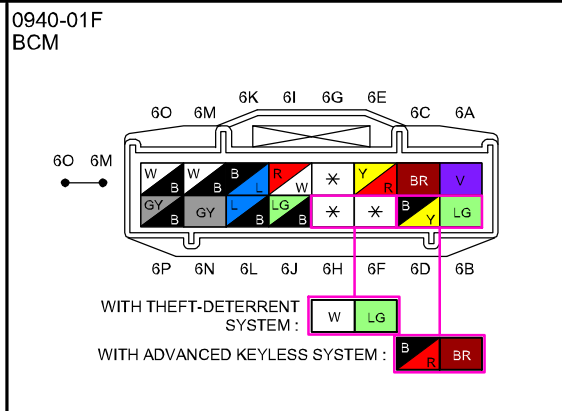
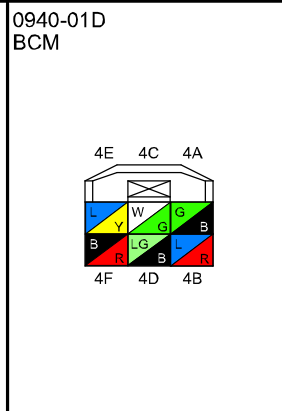
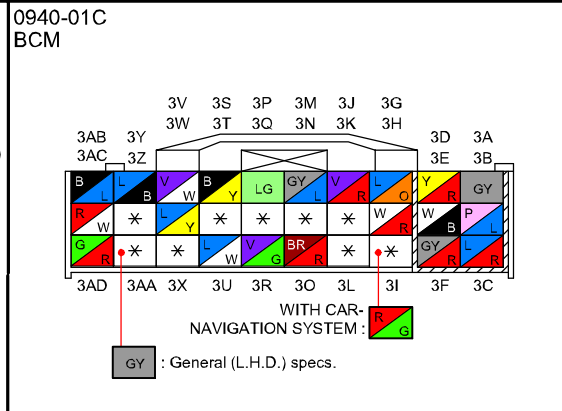
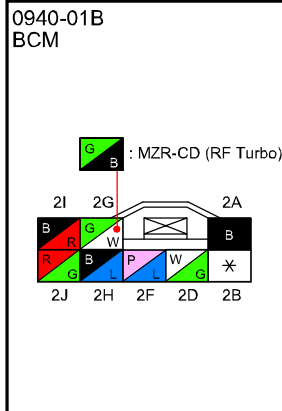
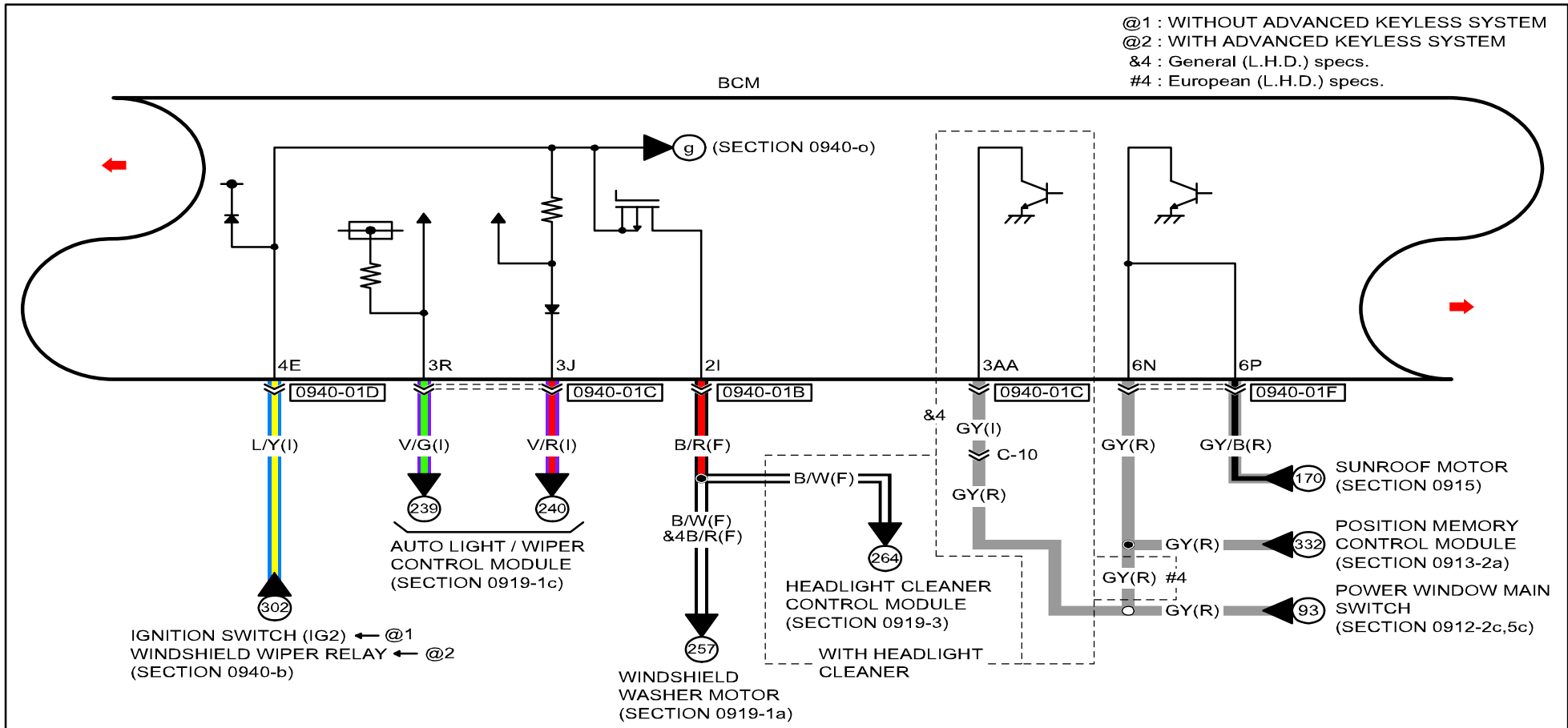

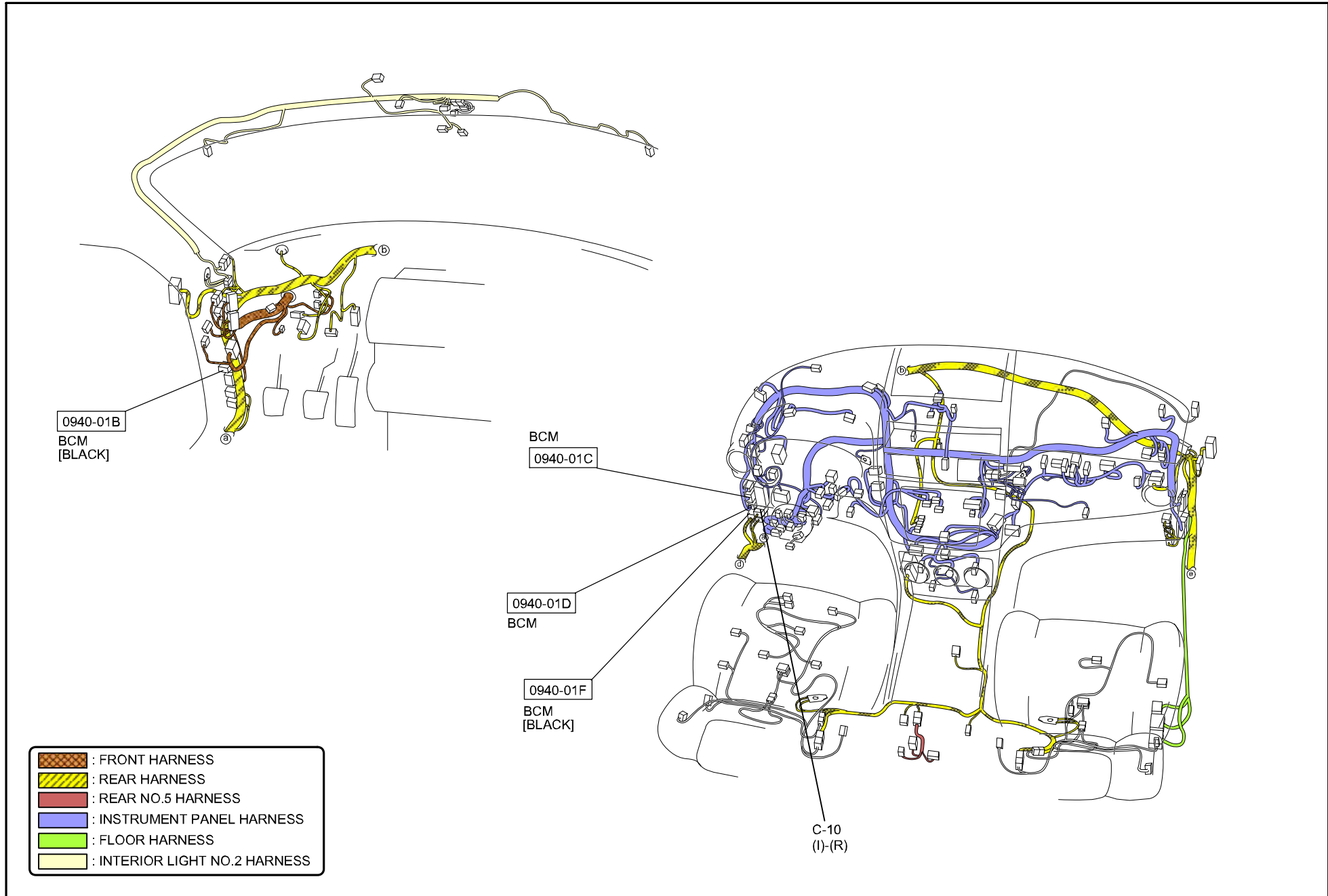

C-10

INSTRUMENT PANEL HARNESS-REAR HARNESS

INSTRUMENT PANEL HARNESS

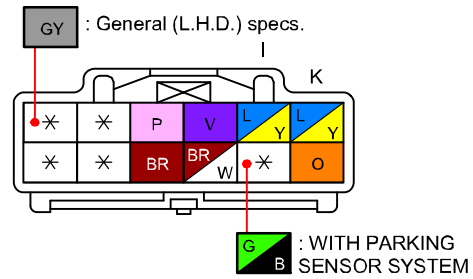

REAR HARNESS

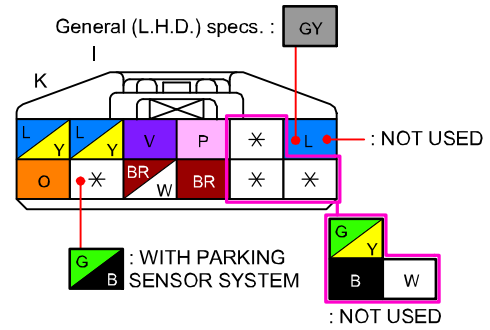

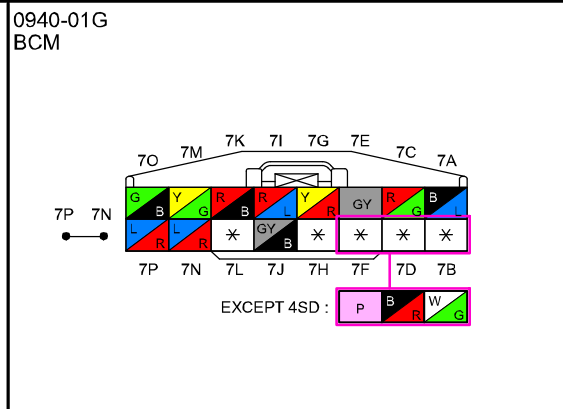
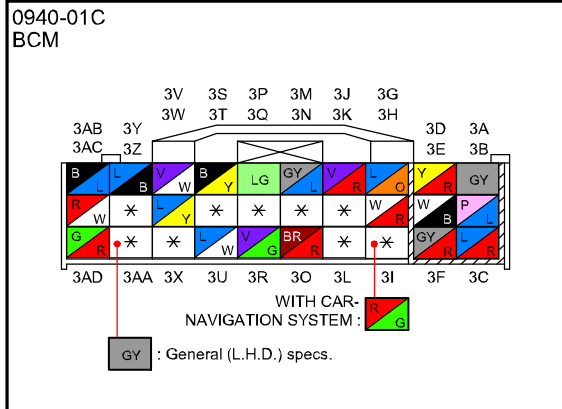
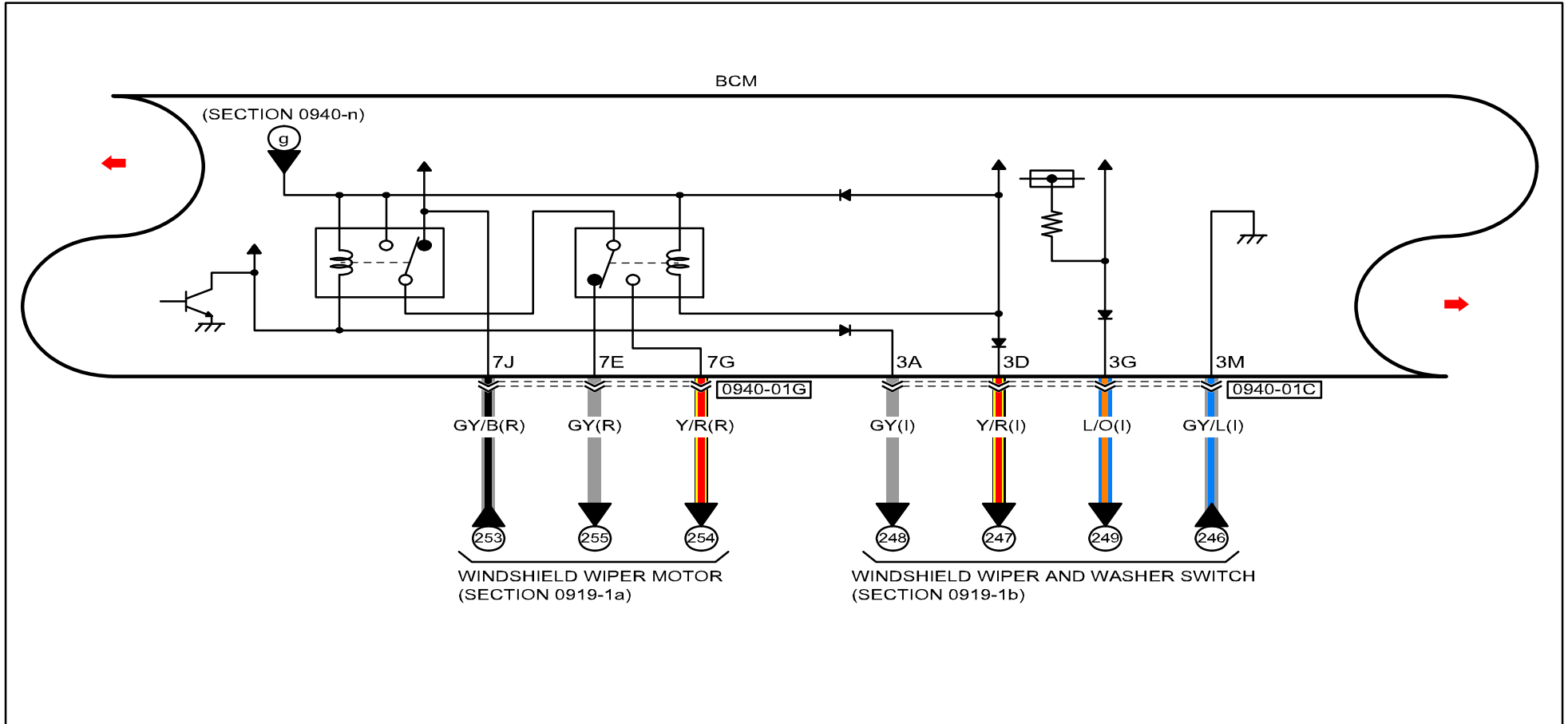





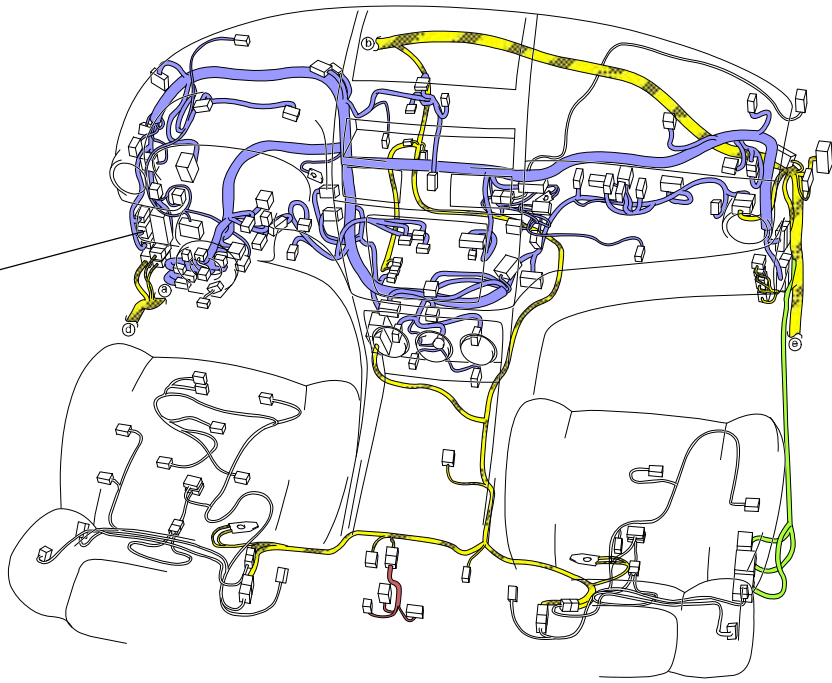

0940-01G
BCM



0940-01C
BCM

-  : FRONT HARNESS
-  : REAR HARNESS
-  : REAR NO.5 HARNESS
-  : INSTRUMENT PANEL HARNESS
-  : FLOOR HARNESS
-  : INTERIOR LIGHT NO.2 HARNESS

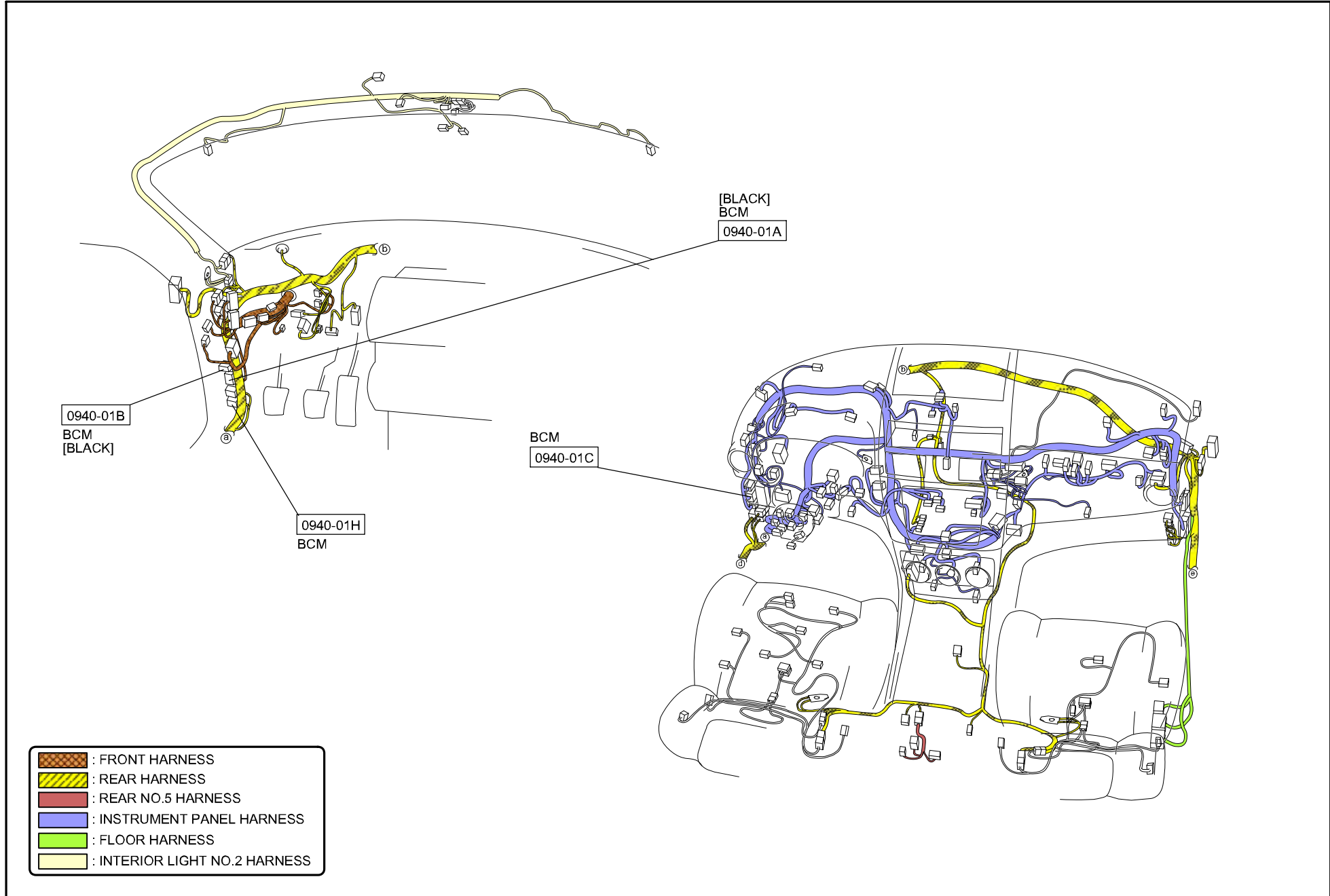

#9 : WITH DOUBLE LOCKING SYSTEM

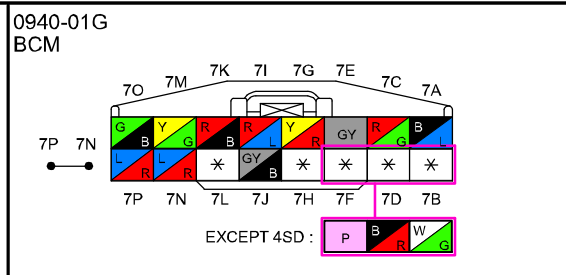
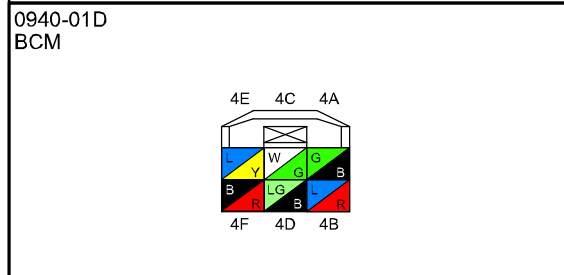
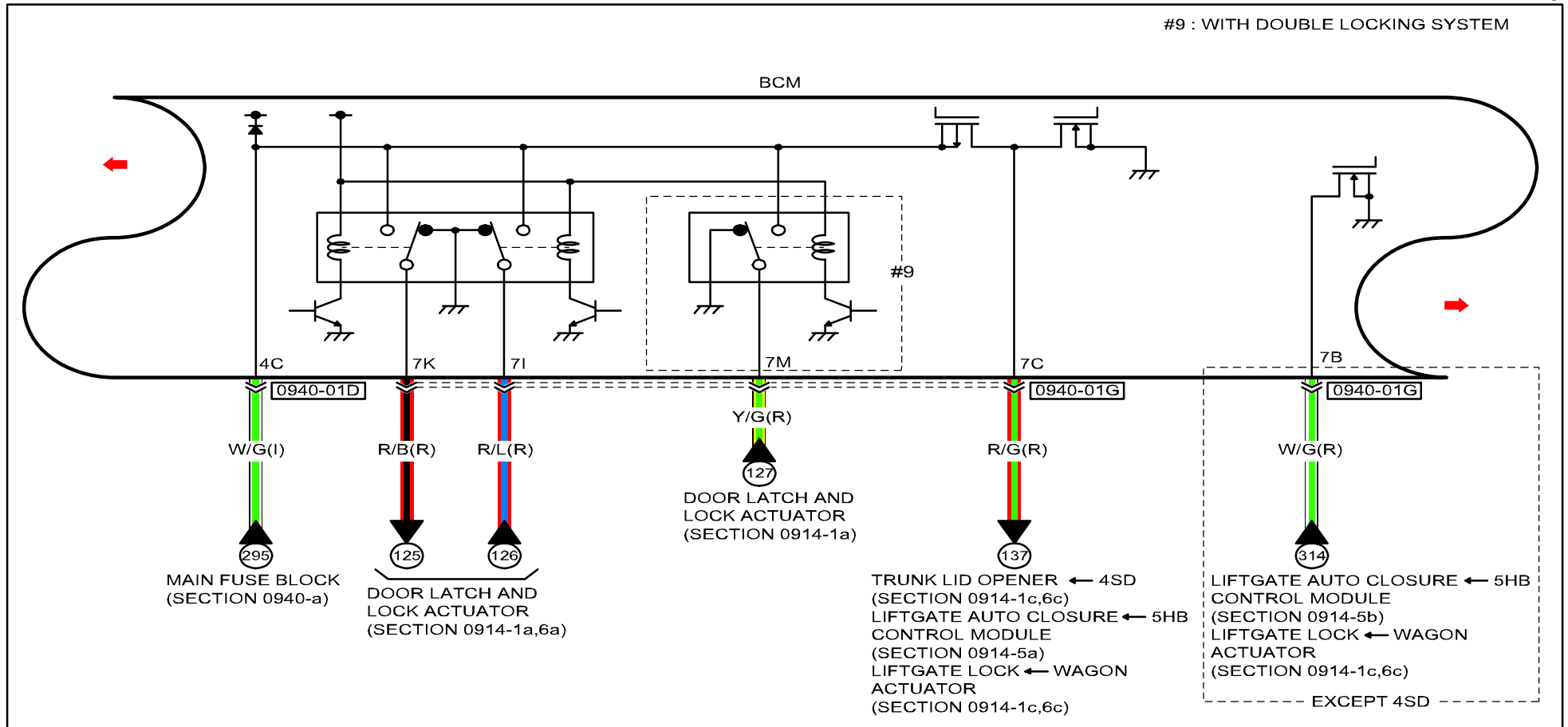

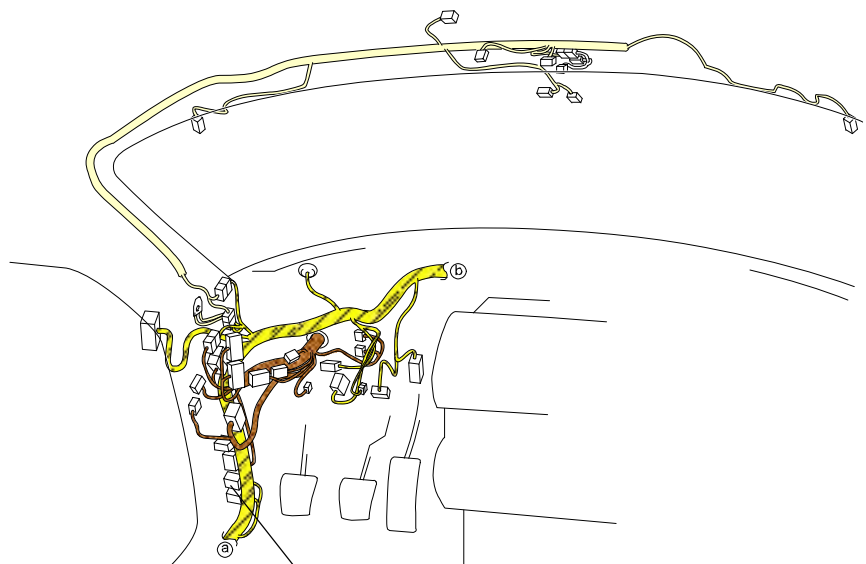





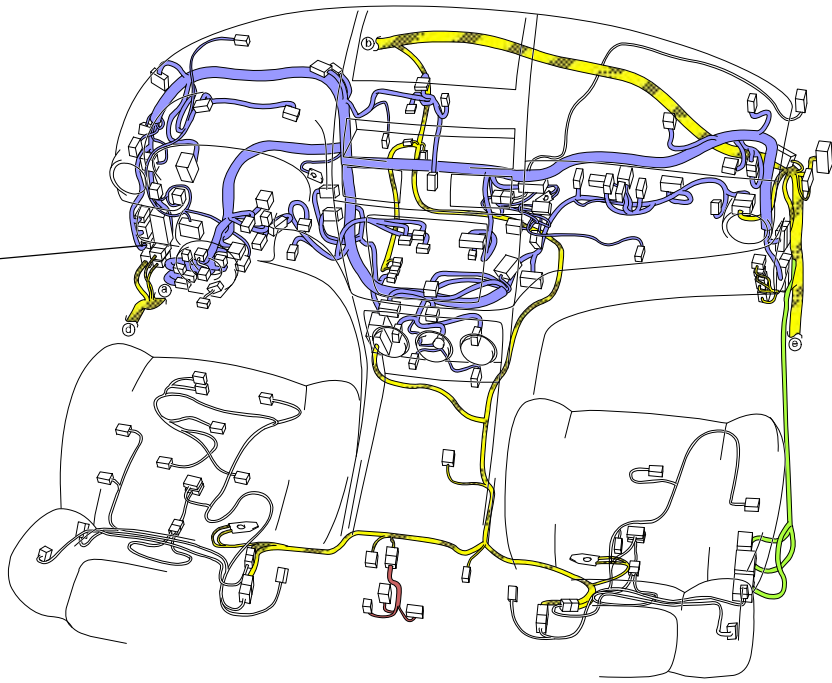

0940-01G
BCM

0940-01D
BCM



-  : FRONT HARNESS
-  : REAR HARNESS
-  : REAR NO.5 HARNESS
-  : INSTRUMENT PANEL HARNESS
-  : FLOOR HARNESS
-  : INTERIOR LIGHT NO.2 HARNESS

@1 : WITHOUT ADVANCED KEYLESS SYSTEM
 @2 : WITH ADVANCED KEYLESS SYSTEM
 #4 : European (L.H.D.) specs.

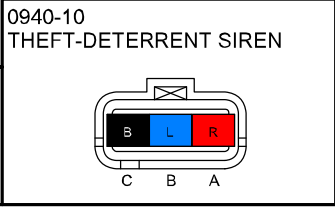
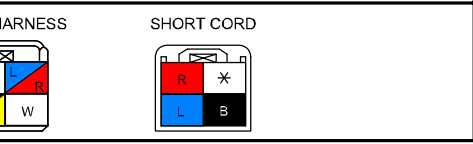
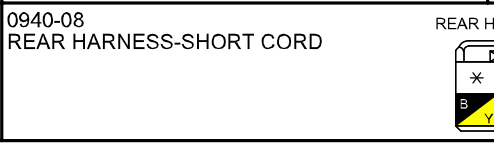
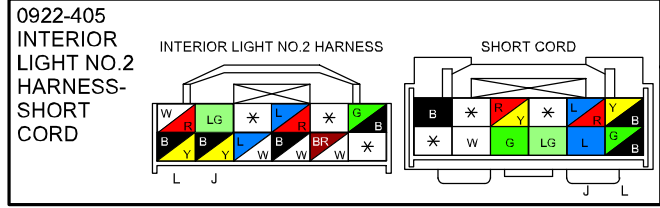
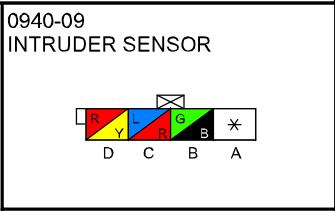
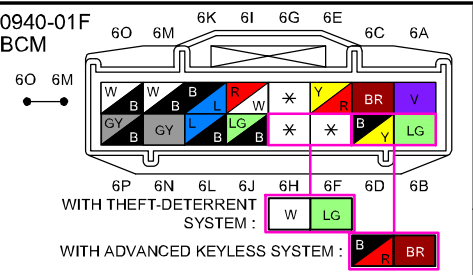
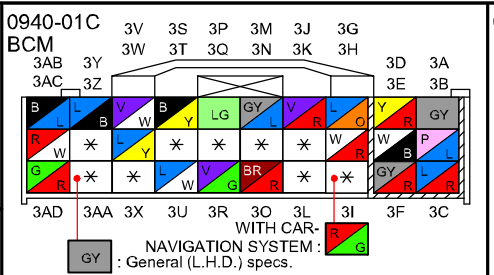
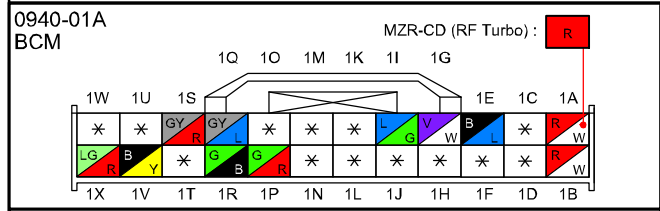
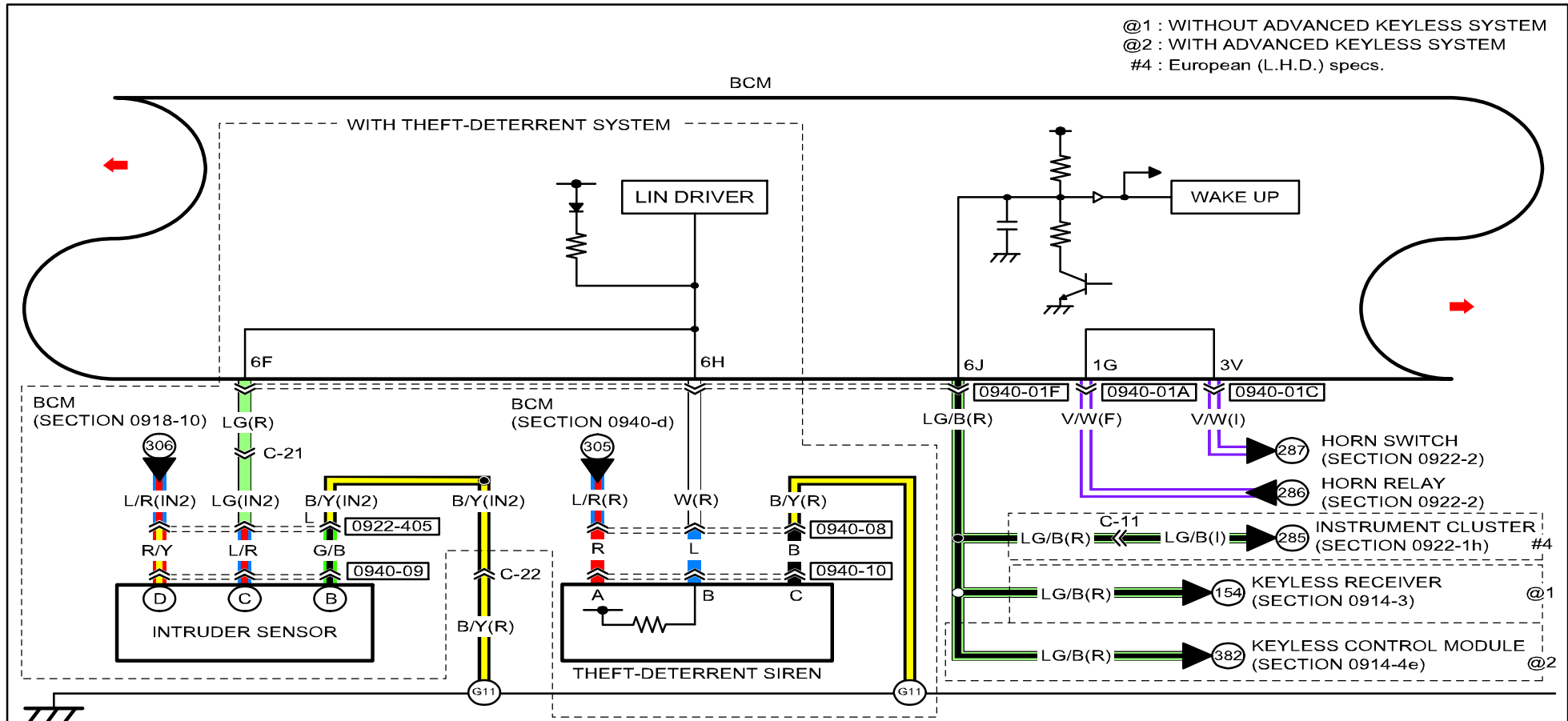

BCM (BODY CONTROL MODULE)

0940-r

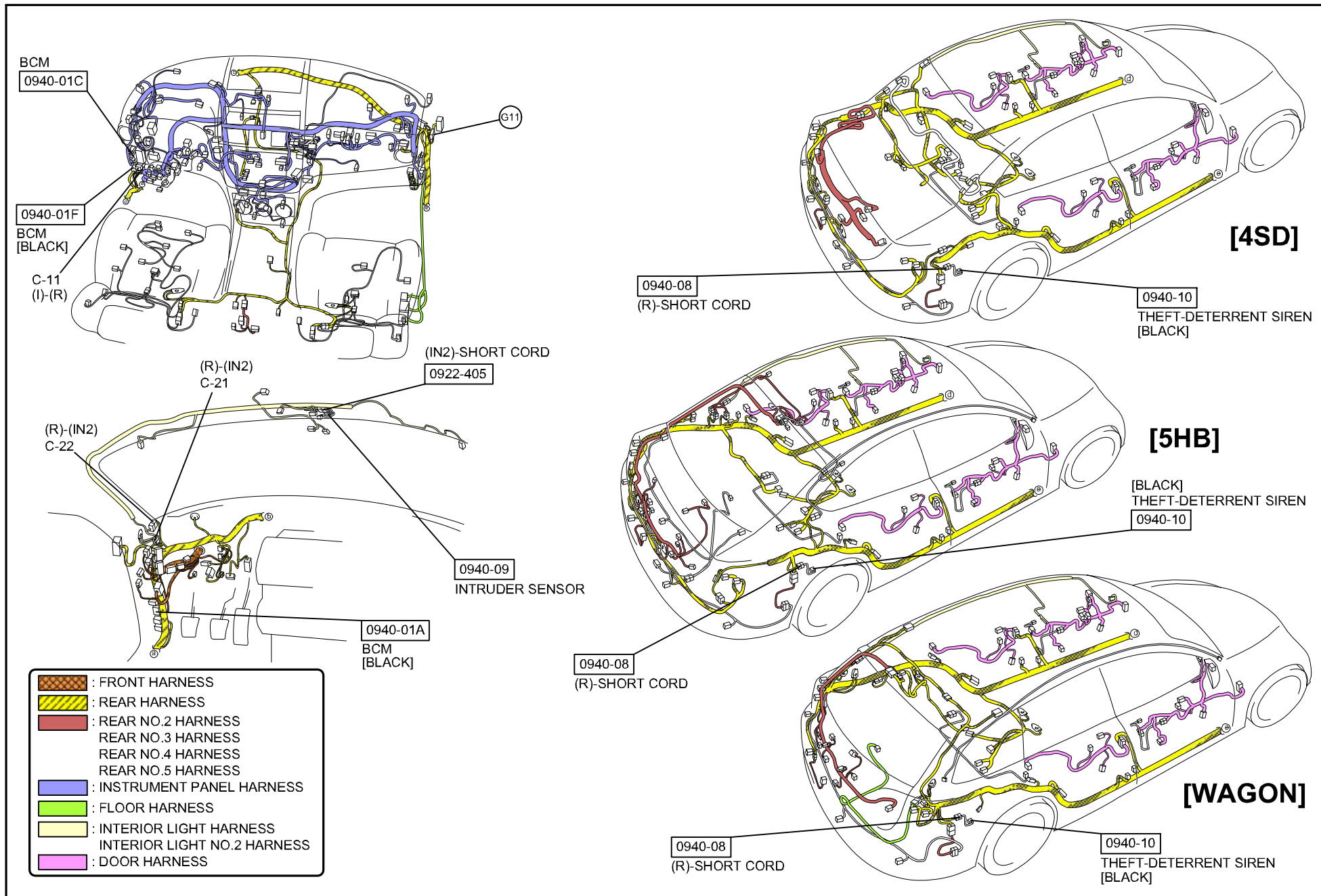

C-11
INSTRUMENT PANEL HARNESS-REAR HARNESS

INSTRUMENT PANEL HARNESS

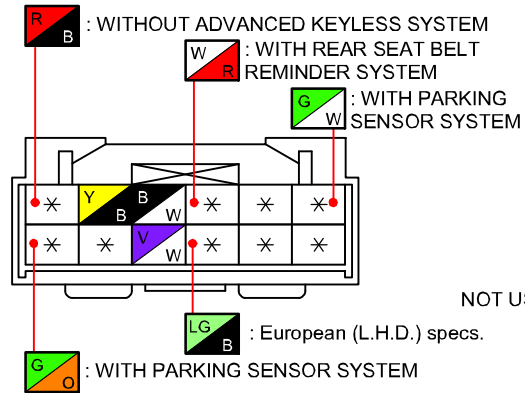

REAR HARNESS

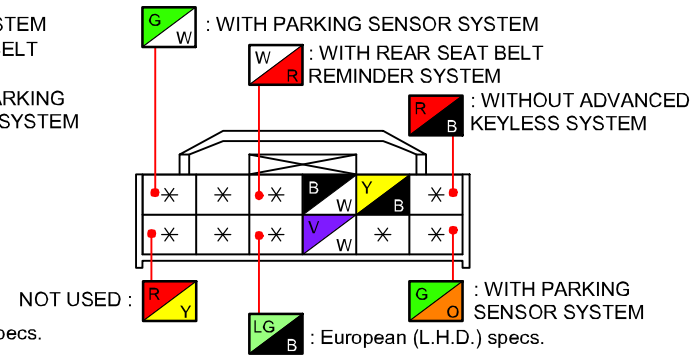

C-21
REAR HARNESS-INTERIOR LIGHT NO.2 HARNESS

REAR HARNESS

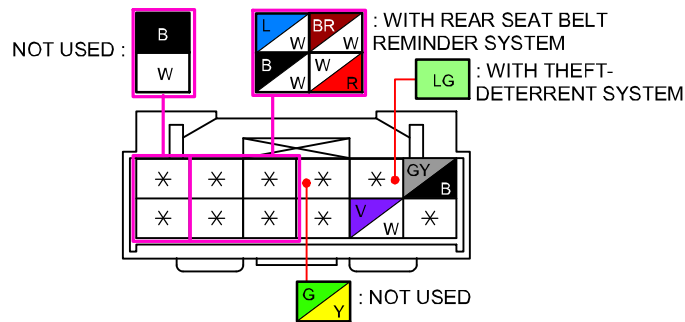

INTERIOR LIGHT NO.2 HARNESS

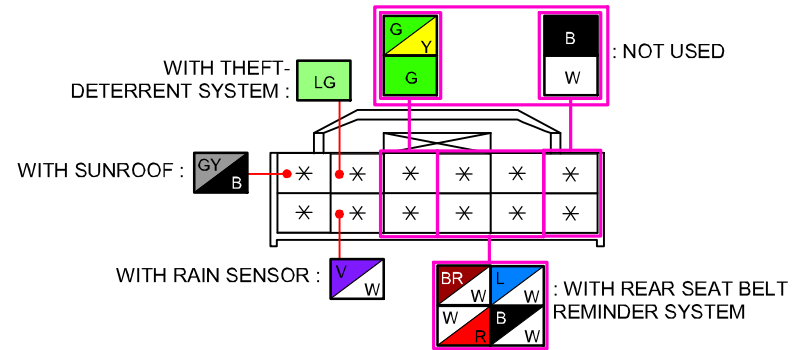

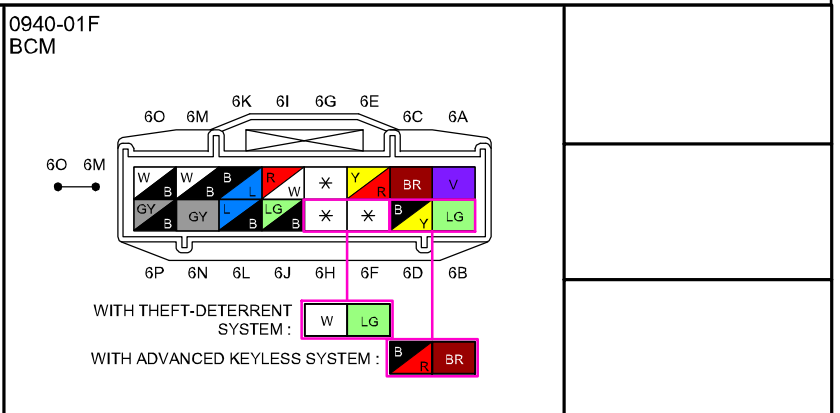
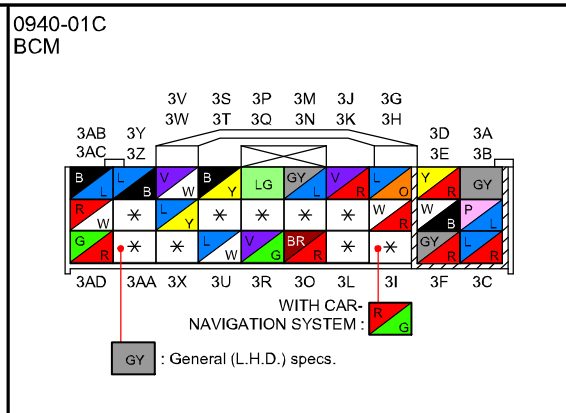
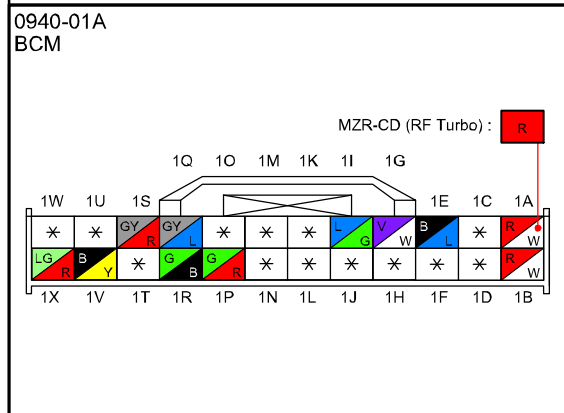
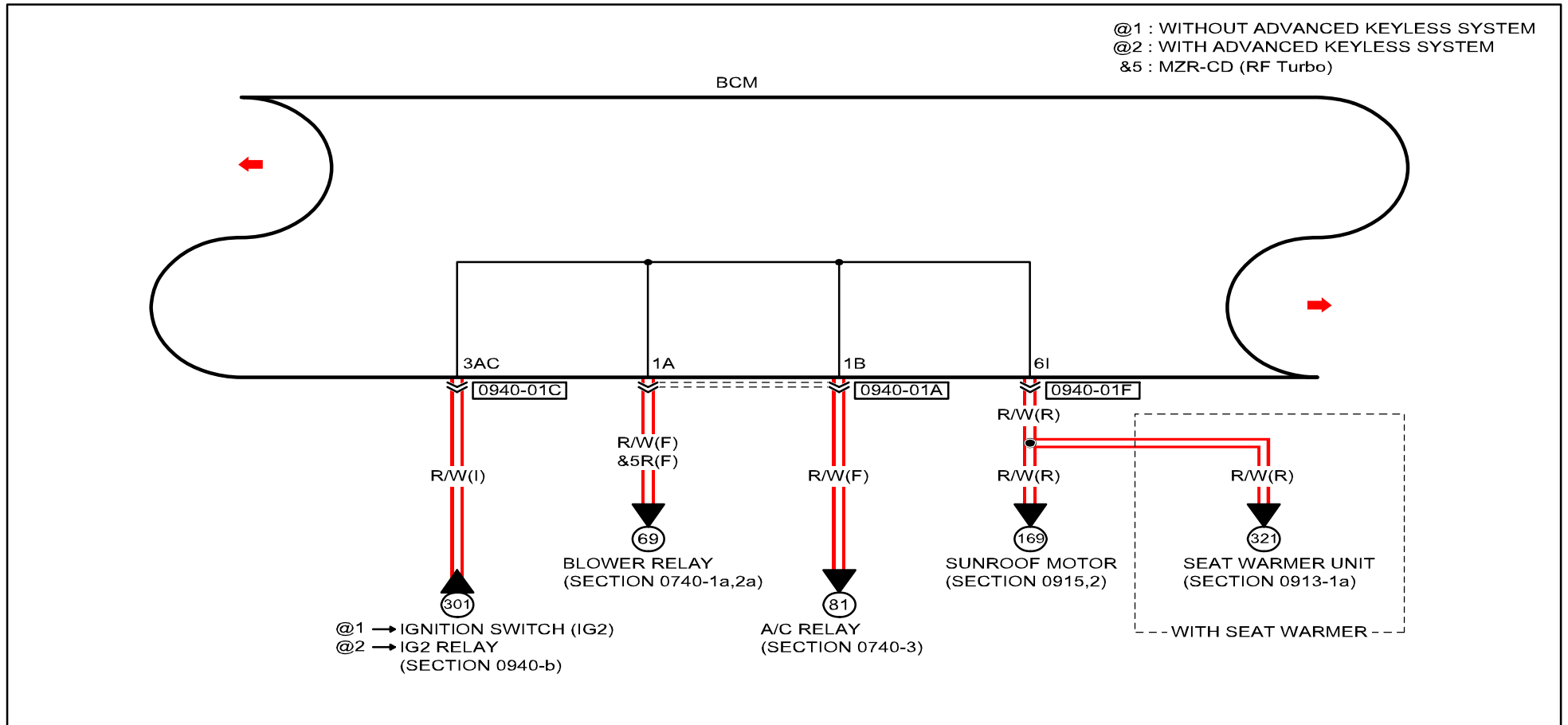



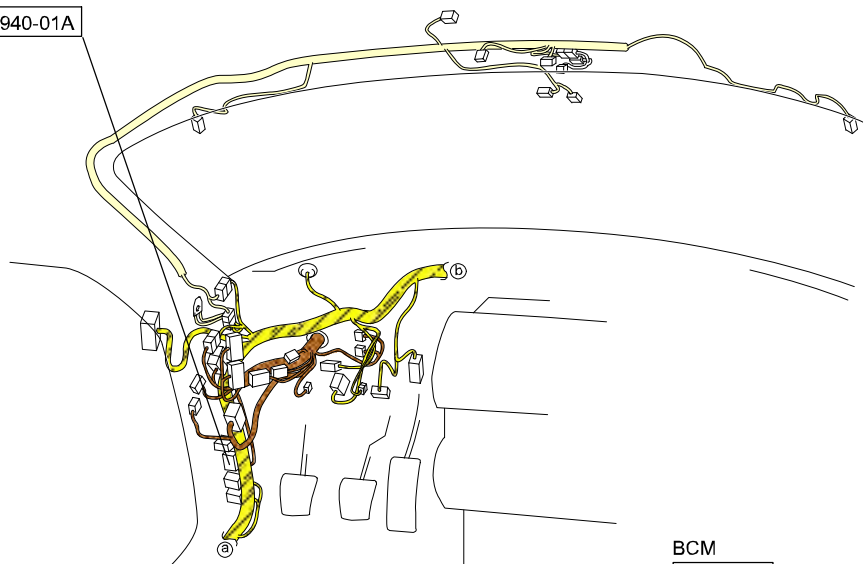



[BLACK]
BCM
0940-01A

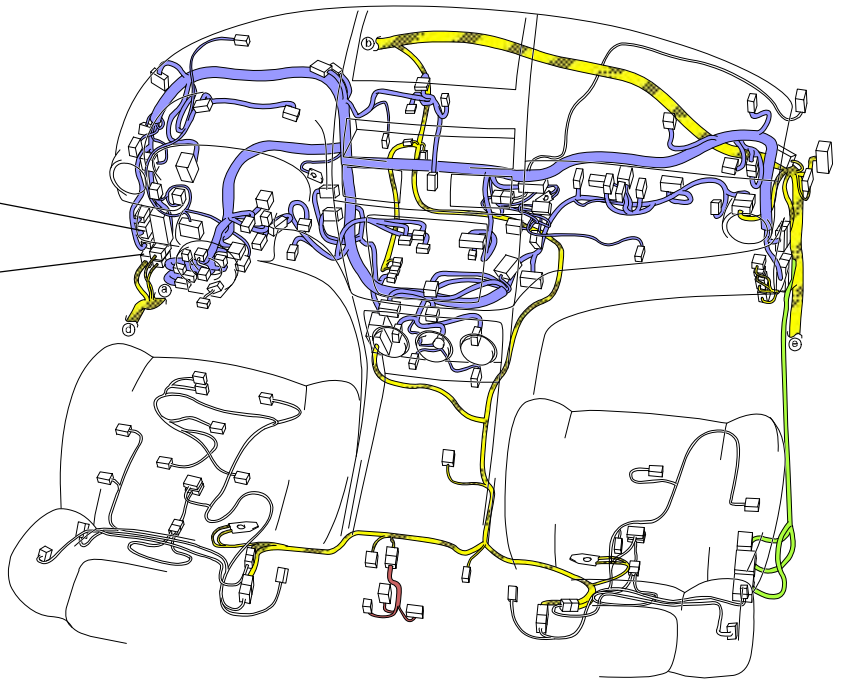

BCM
0940-01C

0940-01F
BCM
[BLACK]



-  : FRONT HARNESS
-  : REAR HARNESS
-  : REAR NO.5 HARNESS
-  : INSTRUMENT PANEL HARNESS
-  : FLOOR HARNESS
-  : INTERIOR LIGHT NO.2 HARNESS

<> : WAGON
 @2 : WITH ADVANCED KEYLESS SYSTEM

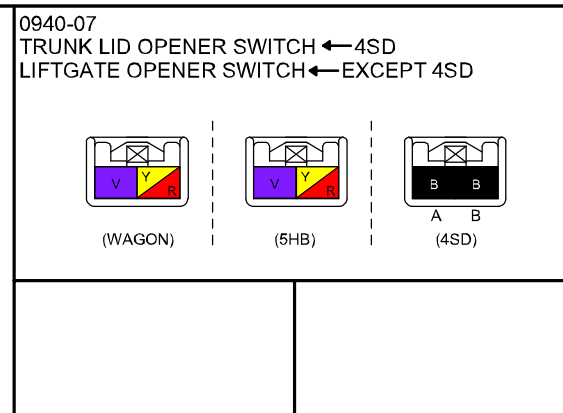
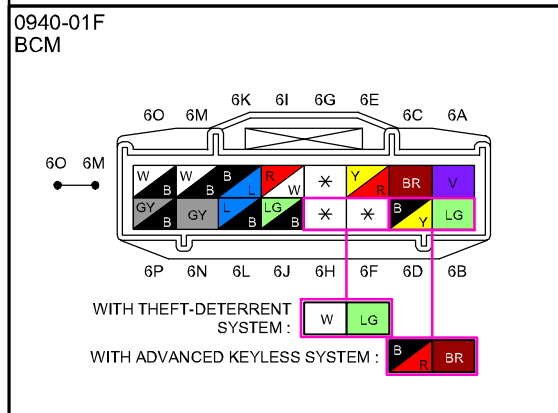
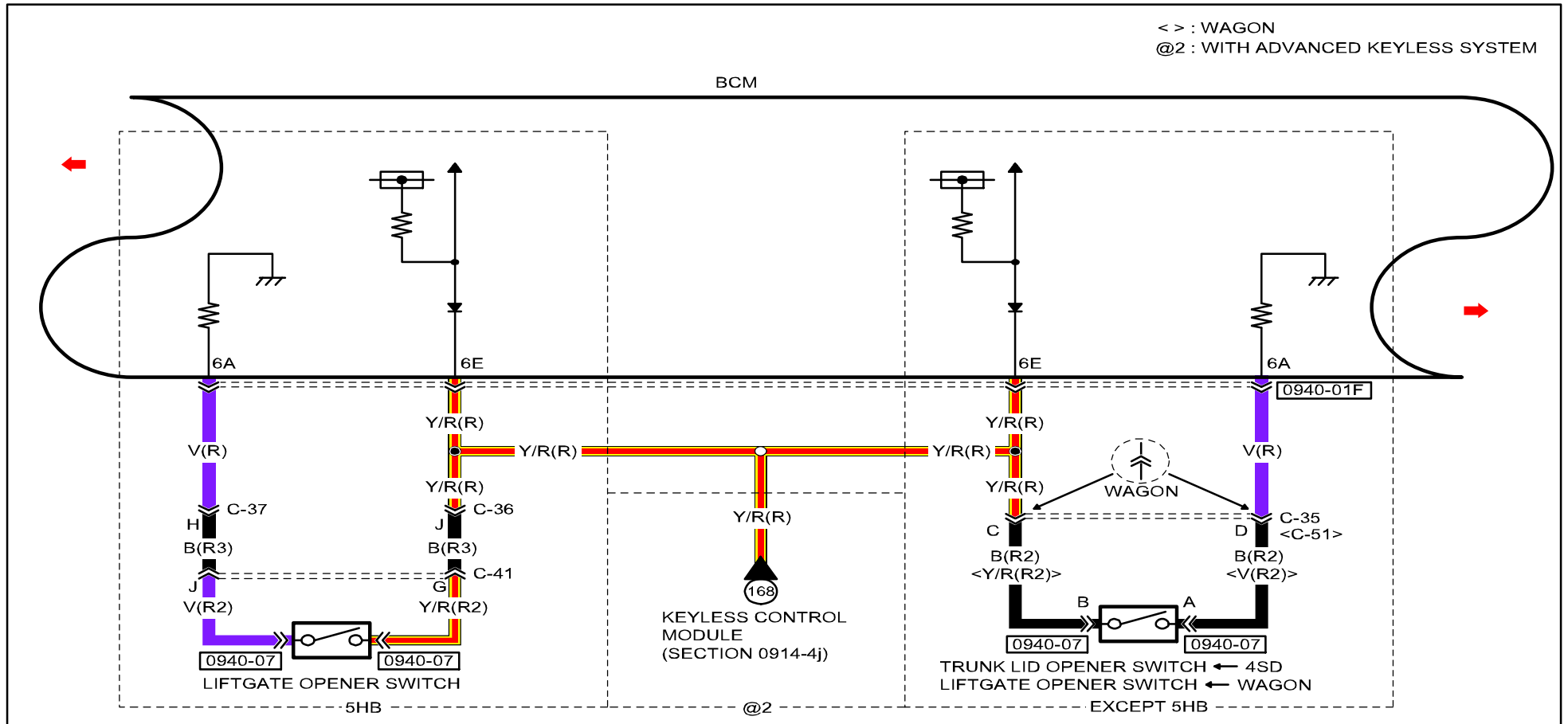

BCM (BODY CONTROL MODULE)

0940-t

- : INSTRUMENT PANEL HARNESS
- : REAR HARNESS
- : REAR NO.2 HARNESS
- : REAR NO.3 HARNESS
- : REAR NO.4 HARNESS
- : REAR NO.5 HARNESS
- : DOOR HARNESS
- : INTERIOR LIGHT HARNESS
- : FLOOR HARNESS

0940-01F
BCM
[BLACK]

(R)-(R2)
C-35

[4SD]

0940-07
TRUNK LID OPENER SWITCH

(R)-(R3)
C-37

(R2)-(R3)
C-41

(R)-(R3)
C-36

(R)-(R2)
C-51

[5HB]

[WAGON]

0940-07
LIFTGATE OPENER SWITCH

0940-07
LIFTGATE OPENER SWITCH

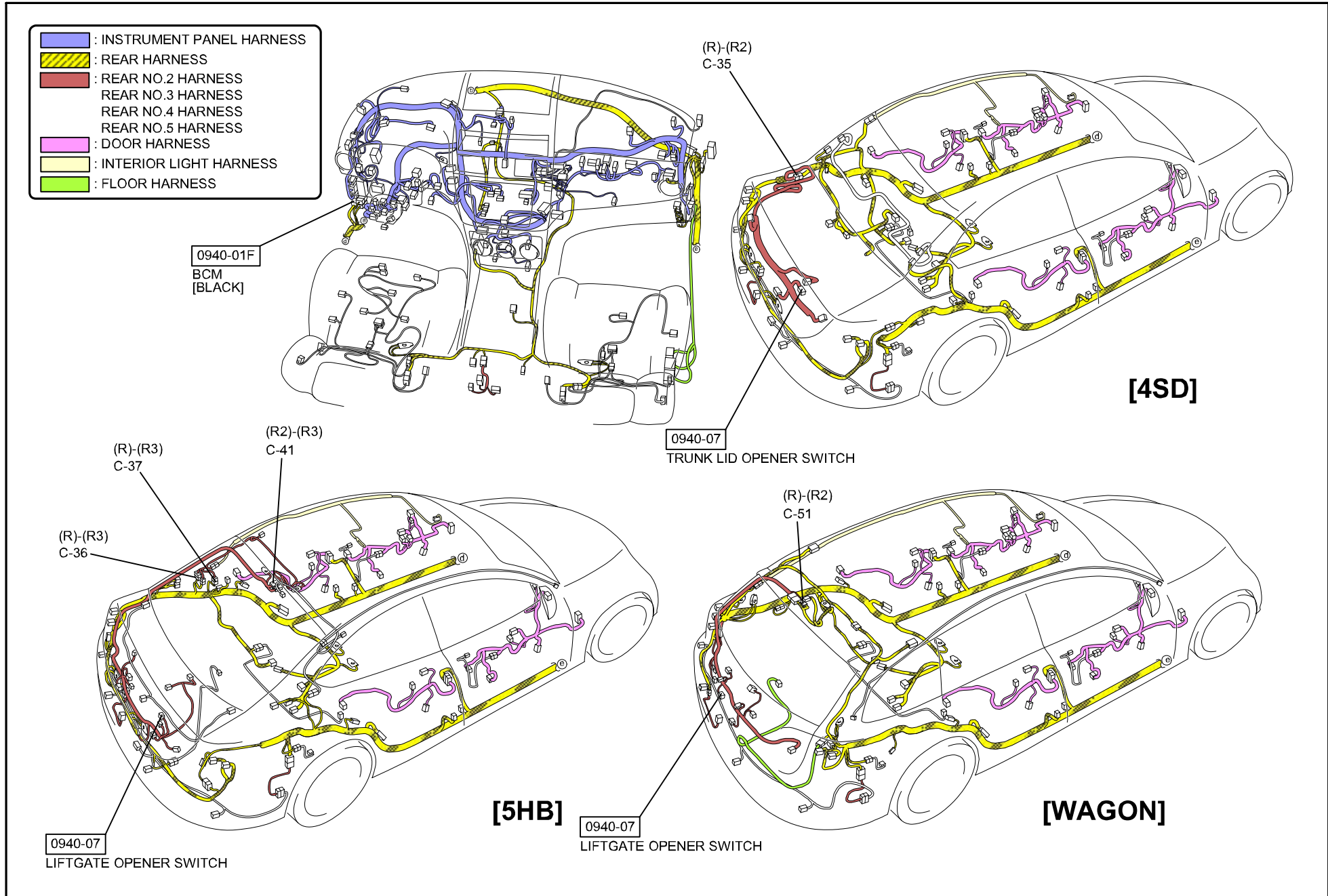

C-35
REAR HARNESS-REAR NO.2 HARNESS

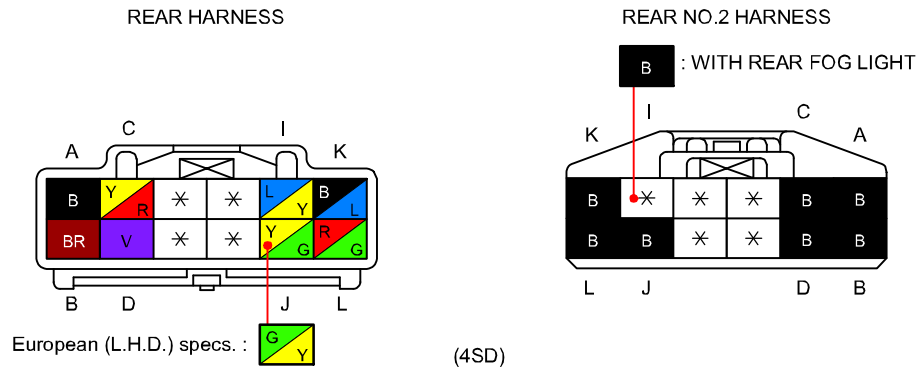

C-36
REAR HARNESS-REAR NO.3 HARNESS

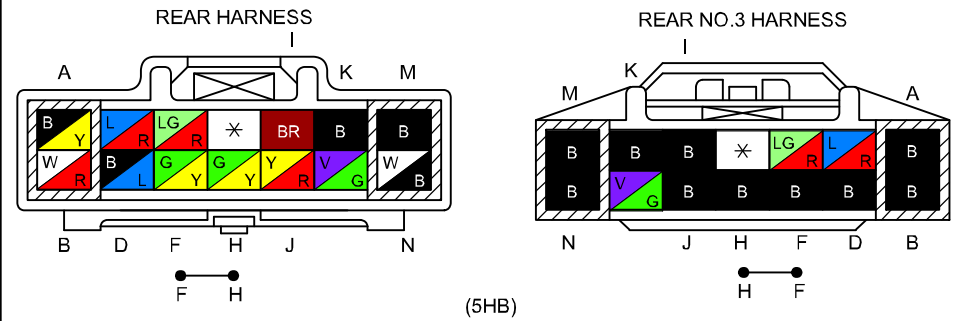

C-37
REAR HARNESS-REAR NO.3 HARNESS

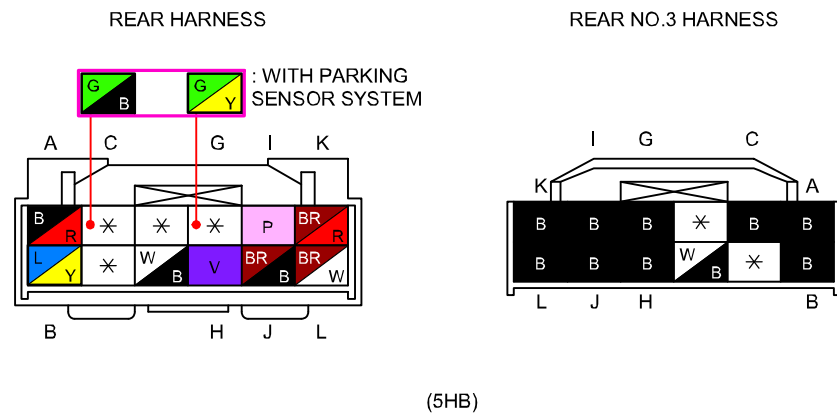

C-41
REAR NO.2 HARNESS-REAR NO.3 HARNESS

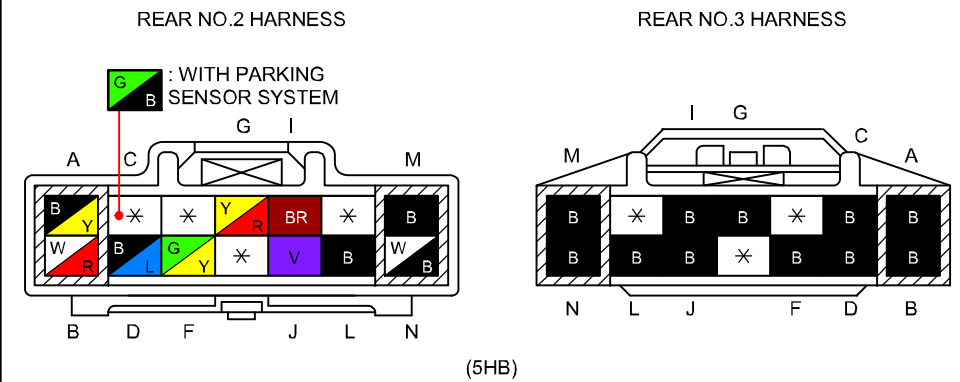

C-51
REAR HARNESS-REAR NO.2 HARNESS

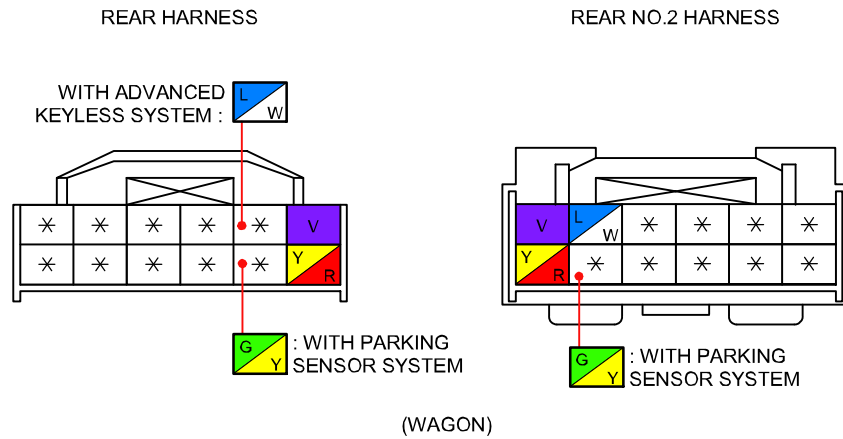

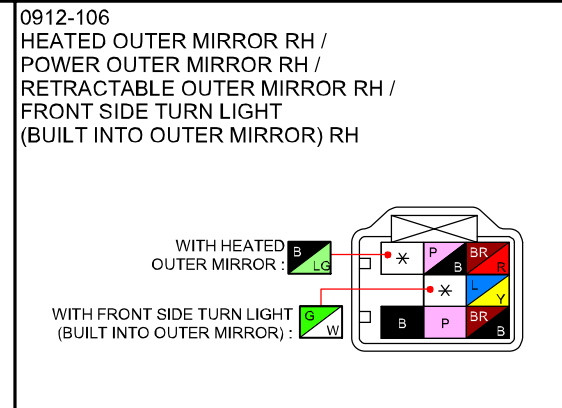
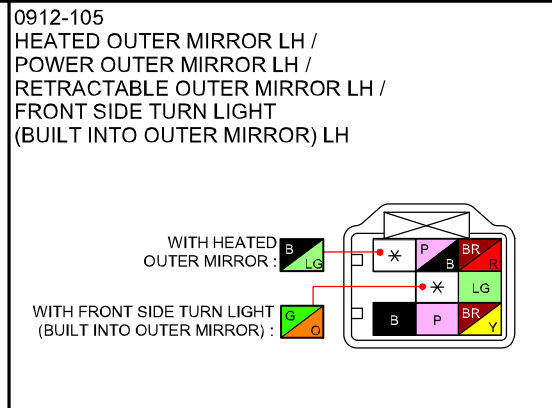
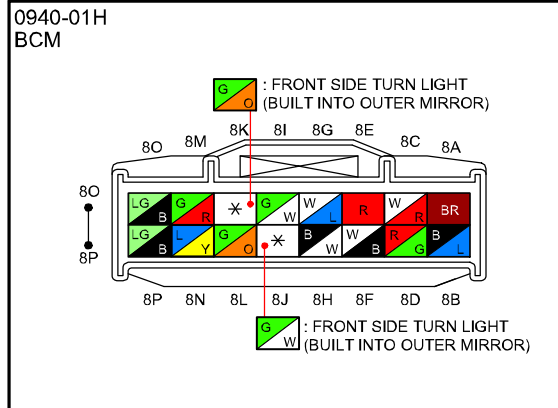
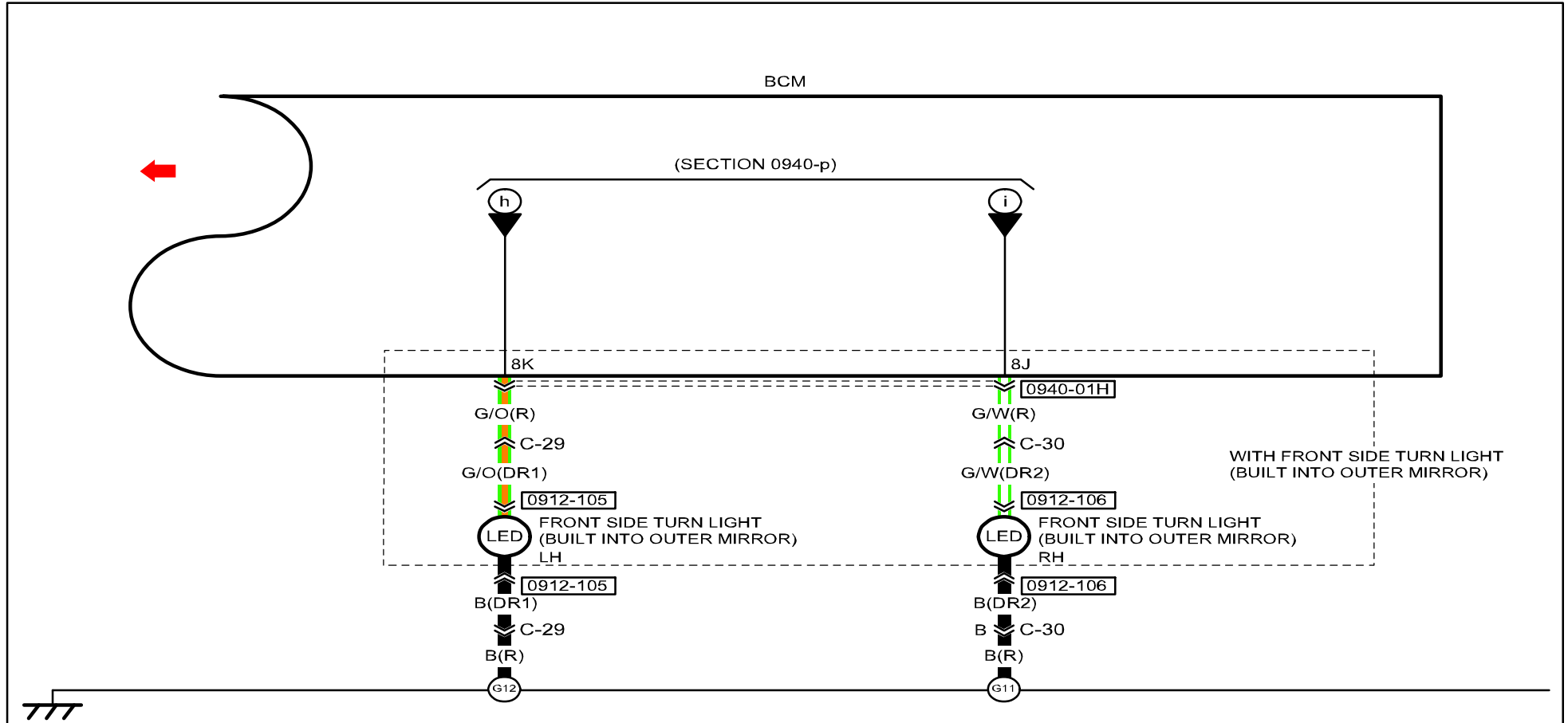

BCM (BODY CONTROL MODULE)

0940-u

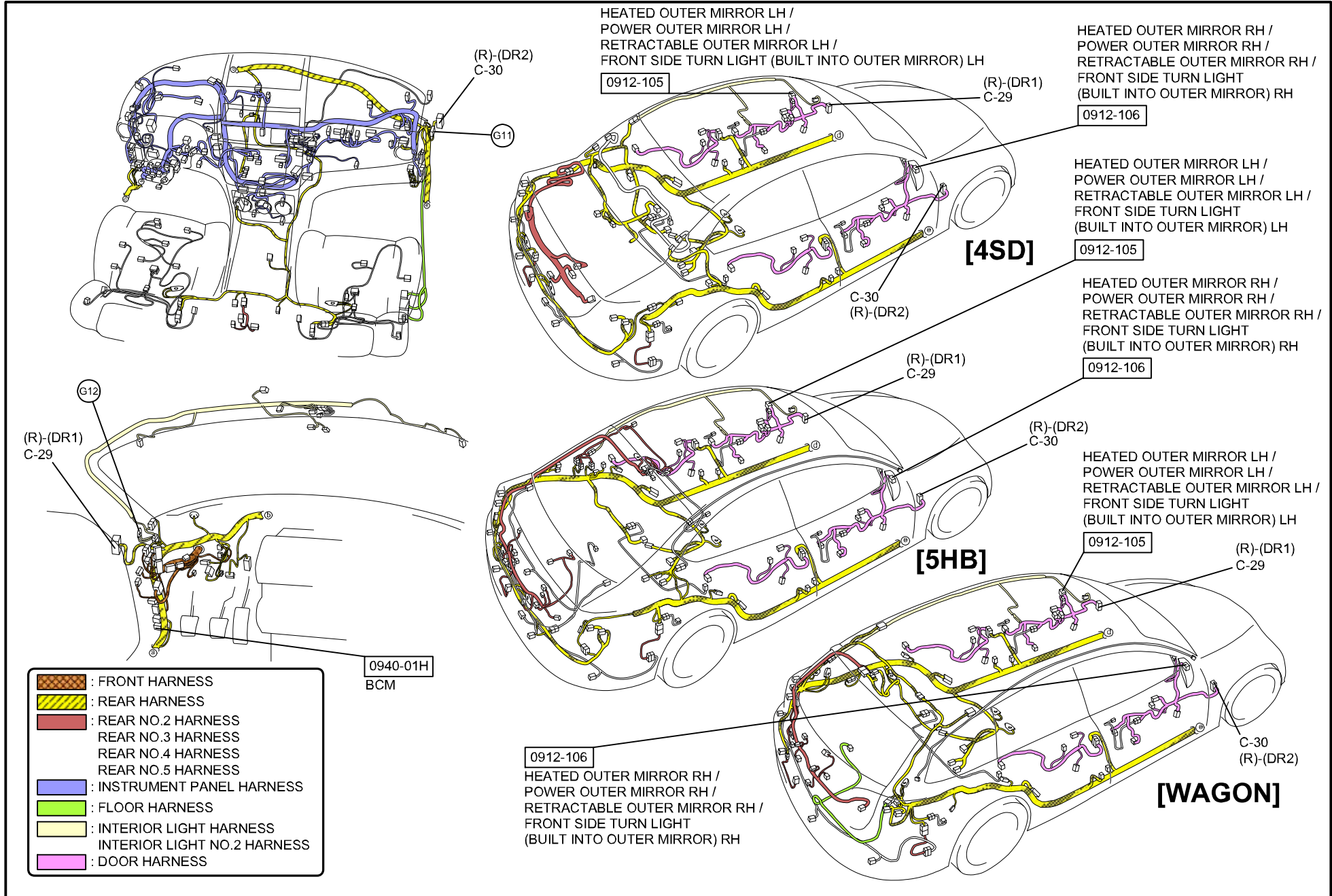

C-30

REAR HARNESS-DOOR NO.2 HARNESS

