

# 5

## In Case of Emergency

ROAD WARNING	5- 2
OVERHEATING	5- 2
EMERGENCY STARTING	5- 3
ELECTRICAL CIRCUIT PROTECTION	5- 5
TOWING	5-13
IF YOU HAVE A FLAT TYRE	5-16

### Hazard Warning Flashers

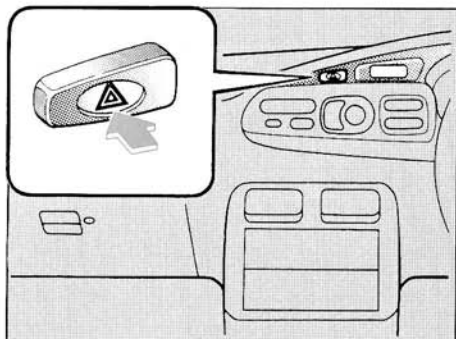

The hazard warning flashers serves as a warning to other drivers to exercise extreme caution when approaching, overtaking, or passing your vehicle. They should be used whenever emergency repairs are being made or when the vehicle is stopped near the edge of a roadway.

Press the flasher switch and all direction indicator lights will flash simultaneously.

#### NOTE

- The direction indicators do not work when the flashers are on.
- Local regulations may prohibit using the warning flashers while the vehicle is being towed.

### Overheating

If your temperature gauge indicates overheating, if you experience a loss of power, or if you hear a loud knocking or pinging noise, the engine has probably overheated. You should follow these procedures if you experience any of these signals.

1. Drive to the side of the road and stop your vehicle; set the automatic transaxle in P (Park), or shift the manual transaxle to neutral and apply the parking brake.
2. Make sure the air conditioner is off.
3. **If coolant or steam is boiling out of the radiator**, stop the engine. Then turn the ignition switch to the ON(II) position, but do not start the engine. The radiator cooling fans will automatically operate with the ignition switch in the ON(II) position. If the cooling fans do not operate, call an Authorized Xedos Dealer for assistance.

**If coolant is not boiling out**, allow the engine to idle and open the bonnet to permit the engine to cool gradually. If the temperature does not go down with the engine idling, stop the engine and allow sufficient time for it to cool.

### Jump-Starting

4. The coolant level should then be checked. If the level in the reservoir is low, look for leaks at the radiator hoses and connections, heater hoses and connections, radiator, and water pump. If you find a major leak or another problem that may have caused the engine to overheat, do not run the engine until it has been repaired. Call an Authorized Xedos Dealer for assistance. If you do not find a leak or other problem, carefully add coolant to the reservoir (page 7-14).

#### **WARNING!**

*Do not remove the radiator cap or coolant filler cap when the engine and radiator are hot. Scalding hot coolant and steam may blow out under pressure. This could cause serious injury.*

#### **CAUTION**

If the engine continues to overheat, have the cooling system checked.

Jump-starting can be dangerous if done incorrectly. Therefore, to avoid harm to yourself or damage to your vehicle or battery, follow jump-starting procedures on the next page. If in doubt, we strongly recommend that you have a competent mechanic or a road service business do any jump-starting of your vehicle.

#### **CAUTION**

**Use only a 12-volt jumper system. You can damage a 12-volt starting motor, ignition system, and other electrical parts beyond repair by use of a 24-volt power supply (two 12-volt batteries in series or a 24-volt motor generator set).**

#### **WARNING!**

- **Keep all flames away from the top of open battery cells, and avoid creating any sparks near the cells.**  
*Gas that can be exploded by a flame or a spark is produced during normal battery operation.*
- **Do not attempt a jump-start if the discharged battery is frozen or if the fluid level is low; the battery may rupture or explode.**

## EMERGENCY STARTING

### Push-Starting

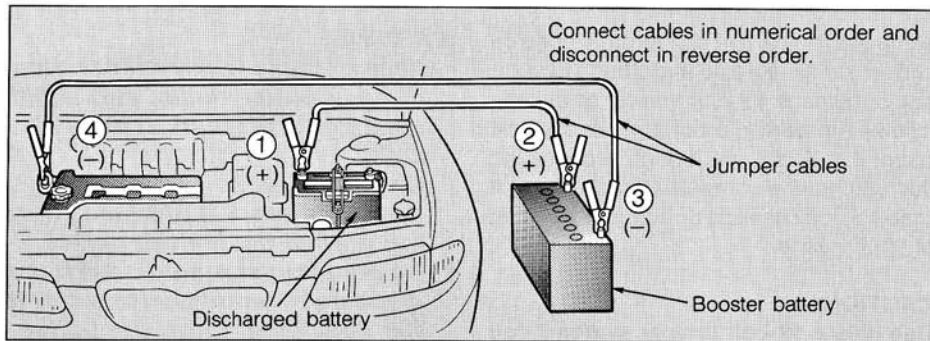

A vehicle with an automatic transaxle cannot be started by pushing. One with a manual transaxle should not be push-started because it could damage the emission control system. Follow the directions on the previous page for jump-starting.

### CAUTION

**Never tow a vehicle to start it because the sudden surge forward when the engine starts could cause a collision with the tow vehicle.**

### JUMP-STARTING PROCEDURE

1. Make sure the booster battery is 12-volt and that its negative terminal is grounded.
2. If the booster battery is in another vehicle, do not allow the vehicles to touch.
3. Turn off all unnecessary electrical loads.
4. Connect the jump leads in the exact sequence in the illustration. First connect one end of a jump lead to the positive terminal of the discharged battery, then the other end to the positive terminal on the booster battery. Next connect one end of the other jump lead to the negative terminal of the booster battery, then the other end to a solid, stationary metallic point (for example, the engine lifting bracket) away from the battery. Do not connect it to or near any part that moves when the engine is cranked and NOT TO THE BATTERY NEGATIVE (-) TERMINAL, being careful that the clamps from one cable do not touch the clamps on the other cable or any metal on either vehicle. Do not lean over the battery when making connections.
5. Start the engine of the vehicle with the booster battery and let it run a few minutes. Then start the engine of the vehicle with the discharged battery.
6. Carefully disconnect the leads in the exact reverse order described in step 4.

## Fuses

The electrical system is protected from overload damage by fuses.

Your vehicle might have more than two fuse panels—one under the driver's side of the instrument panel, the other in the engine compartment near the battery.

If any lights, accessories, or controls do not work, check the appropriate circuit protector. If a fuse has blown, the wire inside it will be melted.

Always replace a blown fuse with one of the same rating.

If the same fuse blows again, avoid using the system involved and immediately consult an Authorized Xedos Dealer.

### NOTE

Two kinds of fuses are used: standard for lower amperage rating and main for higher.

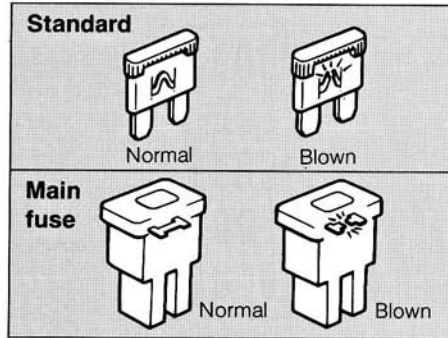

## FUSE REPLACEMENT

### CAUTION

- **Never replace a fuse with anything but another fuse of the same rating. A higher-capacity fuse could cause damage and even start a fire.**
- **Never install a wire instead of the proper fuse—even for a temporary repair. It may cause extensive wiring damage and possibly a fire.**
- **Do not use a screwdriver or any other metal object to remove fuses because it may cause a short circuit and damage the system.**

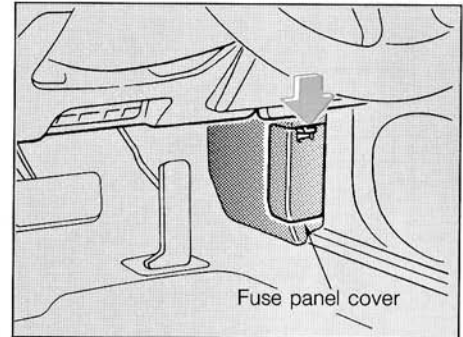

If the electrical system does not work, first inspect the fuses beneath the instrument panel. To do this:

1. Turn off the ignition switch and all other switches.
2. Open the fuse panel cover.

## ELECTRICAL CIRCUIT PROTECTION

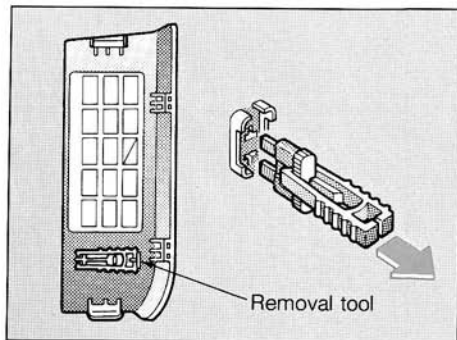

3. Pull out the fuse with the removal tool provided inside the fuse panel cover.
4. Check the fuse and replace it if it is blown.
5. Push in a new fuse of the same rating, and make sure it fits tightly in the clips. If it fits loosely, have an Authorized Xedos Dealer check it.

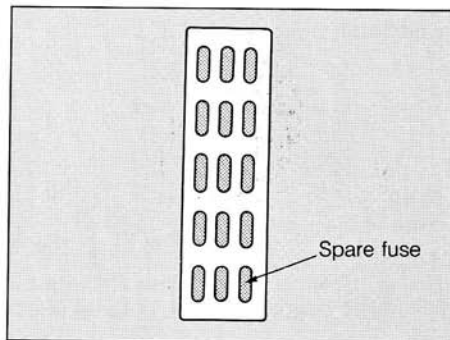

### NOTE

The spare fuse is located in the fuse panel. If you do not have a spare, use a fuse of the same rating from a circuit you may not need for operating the vehicle, such as the RADIO or ROOM.

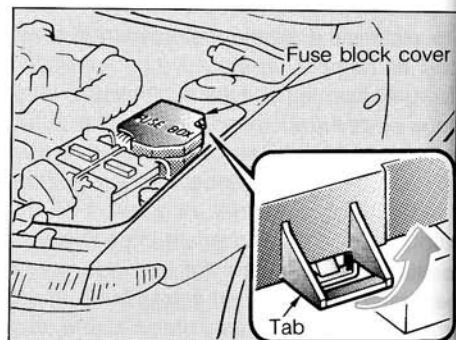

If the headlights or other electrical components do not work and the fuses are OK, check the fuse block in the engine compartment. If a fuse is blown, replace it.

1. Turn off the ignition switch and all other switches.
2. Open the fuse block cover by unhooking the tab and lifting up on the cover.
3. Check the fuses. If one is blown, replace it with a new one of the same rating.

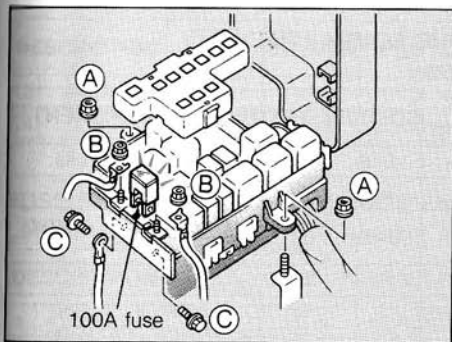

If the 100A fuse is blown, it must be removed as follows.

1. Disconnect the negative battery cable.
2. Remove nuts (A).
3. Remove nuts (B).
4. Lift the fuse block.
5. Remove bolts (C).
6. Replace the fuse with a new one of the same rating.
7. Install in the reverse order of removal.

# ELECTRICAL CIRCUIT PROTECTION

Fuse block

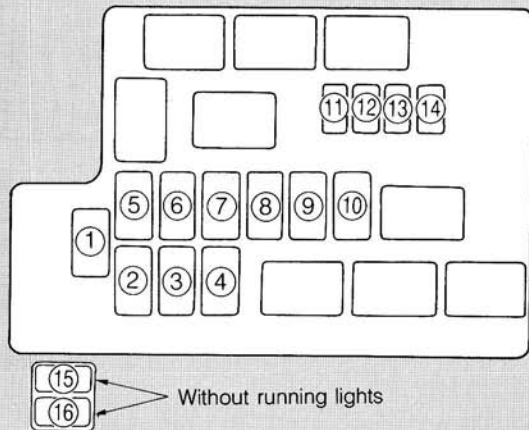

**FUSE BLOCK (ENGINE COMPARTMENT)**  
Right-hand drive model

DESCRIPTION	FUSE RATING	COLOUR	PROTECTED COMPONENT
1 MAIN	100A	Blue	For protection of all circuits
2 HEAD	40A	Green	Headlight high beams
3 DEFOG	40A	Green	Rear window defroster, Mirror defroster
4 EGI INJ	30A	Pink	Fuel injection system
5 IG KEY	40A	Green	RADIO, SUNROOF, TURN, METER, ENGINE, POWER WINDOW, HEADLIGHT CLEANER and WIPER fuses, Ignition system
6 BTN	60A	Yellow	STOP, ROOM, DOOR LOCK and POWER WINDOW fuses
7 ABS*	60A	Yellow	Antilock brake system
8 COOLING FAN	40A	Green	Cooling fan
9 HEATER	40A	Green	Heater, Air conditioner
10 AIR COND*	40A	Green	Air conditioner
11 TAIL	15A	Blue	Tail lights, Parking lights, Instrument panel illumination, License plate lights, Glove box light
12 FOG*	15A	Blue	Front fog lights



## ELECTRICAL CIRCUIT PROTECTION

DESCRIPTION	FUSE RATING	COLOUR	PROTECTED COMPONENT
13 AUDIO*	20A	Yellow	Audio system
14 FAN*	30A	Green	Cooling fan

### FUSE BLOCK (ENGINE COMPARTMENT) Left-hand drive model (With running lights)

DESCRIPTION	FUSE RATING	COLOUR	PROTECTED COMPONENT
1 MAIN	100A	Blue	For protection of all circuits
2 HEAD	40A	Green	Headlight high beams
3 DEFOG	40A	Green	Rear window defroster, Mirror defroster
4 EGI INJ	30A	Pink	Fuel injection system
5 IG KEY	40A	Green	RADIO, SUNROOF, TURN, METER, ENGINE, POWER WINDOW, HEADLIGHT CLEANER and WIPER fuses, Ignition system
6 BTN	60A	Yellow	STOP, ROOM, DOOR LOCK and POWER WINDOW fuses
7 ABS*	60A	Yellow	Antilock brake system
8 COOLING FAN	40A	Green	Cooling fan

DESCRIPTION	FUSE RATING	COLOUR	PROTECTED COMPONENT
9 HEATER	40A	Green	Heater, Air conditioner
10 AIR COND*	40A	Green	Air conditioner
11 TAIL	15A	Blue	Tail lights, Parking lights, Instrument panel illumination, License plate lights, Glove box light
12 FOG*	15A	Blue	Front fog lights
13 R.FOG	15A	Blue	Rear fog lights
14 —	—	—	—

# ELECTRICAL CIRCUIT PROTECTION

## FUSE BLOCK (ENGINE COMPARTMENT)

Left-hand drive model (Without running lights)

DESCRIPTION	FUSE RATING	COLOUR	PROTECTED COMPONENT
1 MAIN	100A	Blue	For protection of all circuits
2 HAZARD	30A	Pink	Hazard warning lights
3 DEFOG	40A	Green	Rear window defroster, Mirror defroster
4 EGI INJ	30A	Pink	Fuel injection system
5 STOP	30A	Pink	Brake lights
6 BTN	60A	Yellow	STOP, ROOM, DOOR LOCK and POWER WINDOW fuses
7 ABS*	60A	Yellow	Antilock brake system
8 COOLING FAN	40A	Green	Cooling fan
9 HEATER	40A	Green	Heater, Air conditioner
10 AIR COND*	40A	Green	Air conditioner
11 MAIN.LH	15A	Blue	Left-side high beam
12 MAIN.RH	15A	Blue	Right-side high beam

DESCRIPTION	FUSE RATING	COLOUR	PROTECTED COMPONENT
13 DIM.LH	15A	Blue	Left-side low beam
14 DIM.RH	15A	Blue	Right-side low beam
15 TAIL.RH	15A	Blue	Tail lights, Parking lights, Instrument panel illumination, License plate lights, Glove box light, Rear fog lights
16 TAIL.LH	15A	Blue	Tail lights, Fog lights

Fuse panel

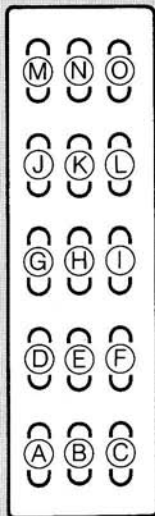

## FUSE PANEL

### Right-hand drive model

DESCRIPTION	FUSE RATING	COLOUR	PROTECTED COMPONENT
A STOP	20A	Yellow	Brake lights, horn
B ROOM	15A	Blue	Interior lights, boot light
C SPARE	15A	Blue	Spare fuse
D DOOR LOCK	30A	Green	Power door lock
E RADIO	15A	Blue	Audio system, clock, cigarette lighter, outside mirror, auto antenna
F SUNROOF*	15A	Blue	Sunroof
G —	—	—	—
H POWER WINDOW	30A	Green	Power window, lighter
I METER	15A	Blue	Gauges, back-up lights
J TURN	15A	Blue	Direction indicator lights
K ENGINE	15A	Blue	Engine control system
L —	—	—	—
M REAR FOG	15A	Blue	Rear fog light
N WIPER	20A	Yellow	Windshield wipers and washer
O —	—	—	—

\* Some models.

# ELECTRICAL CIRCUIT PROTECTION

## FUSE PANEL

### Left-hand drive model

DESCRIPTION	FUSE RATING	COLOUR	PROTECTED COMPONENT
A STOP	15A	Blue	Brake lights, horn
B ROOM	15A	Blue	Interior lights, boot light
C SPARE	15A	Blue	Spare fuse
D DOOR LOCK	30A	Green	Power door lock
E RADIO	15A	Blue	Audio system, clock, cigarette lighter, outside mirror, auto antenna
F SUNROOF*	15A	Blue	Sunroof
G —	—	—	—
H POWER WINDOW	30A	Green	Power window, lighter
I METER	15A	Blue	Gauges, back-up lights
J TURN	15A	Blue	Direction indicator lights
K ENGINE	15A	Blue	Engine control system
L HEAD CLEANER*	20A	Yellow	Headlight cleaner
M REAR FOG	15A	Blue	Rear fog light
N WIPER	20A	Yellow	Windshield wipers and washer
O SEAT WARMER*	15A	Blue	Seat warmer

## Towing

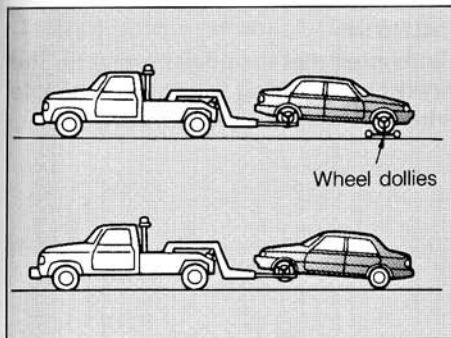

If towing is necessary, we recommend having it done by an Authorized Xedos Dealer or a commercial tow-truck service. Proper lifting and towing procedures are necessary to prevent damage to the vehicle. Governmental laws applicable to vehicles in tow must be followed.

As a general rule, towed vehicles should be towed with the front wheels off the ground or transported on a flat bed truck.

When towing with the rear wheels on the ground, release the parking brake.

If excessive damage or other conditions prevent towing the vehicle with the front wheels off the ground, use wheel dollies.

**CAUTION**

**Do not start or run the engine while vehicle is being towed.**

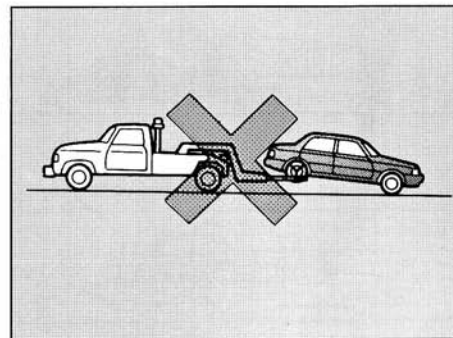
**CAUTION**

**Do not tow the vehicle backward with the front wheels on the ground. This may cause damage to the transaxle.**

## TOWING

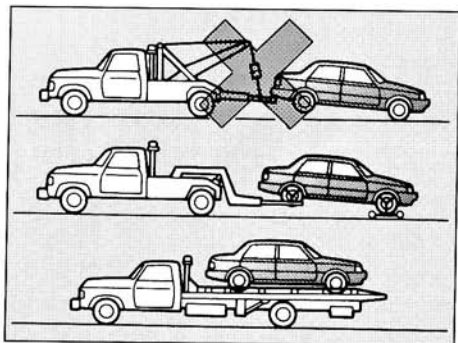

### CAUTION

**Do not tow with sling-type equipment.  
Use wheel lift or flat bed equipment.**

If it is necessary to tow the vehicle with all wheels on the ground, the vehicle may be towed only forward at LESS than 56 km/h (35 mph) and for a MAXIMUM distance of 80 km (50 miles). Failure to observe this rule could result in transaxle damage.

### NOTE

If towing speed must exceed 56 km/h (35 mph) or if the towing distance must exceed 80 km (50 miles), your vehicle must be towed with the driving wheels off the ground or transported by flat bed truck.

The following points are important when towing a vehicle with all wheels on the ground.

With either automatic or manual transaxle:

1. Set the ignition switch in the ACC(I) position;
2. Place the selector lever or shift lever in N (Neutral);
3. Release the parking brake.

### CAUTION

**Remember that the power assist for the brakes and steering will not be available when the engine is inoperative.**

Towing hook — Front

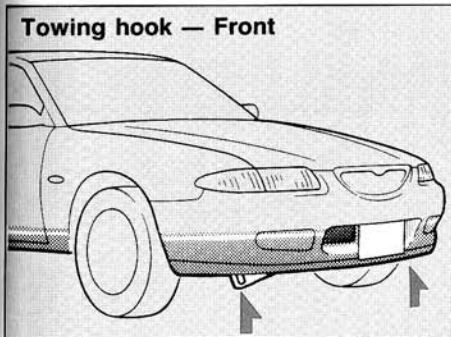

Towing hook — Rear

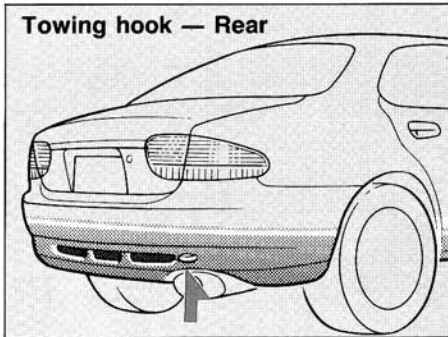
**Towing Hooks**

The towing hooks should be used only in an emergency (to get the vehicle out of a ditch or a snow bank, for example).

**CAUTION**

When using the towing hooks, always pull the cable or chain in a straight direction with respect to the hook. Apply no sideways force.

## IF YOU HAVE A FLAT TYRE

### Storing Tyre, Jack, and Tools

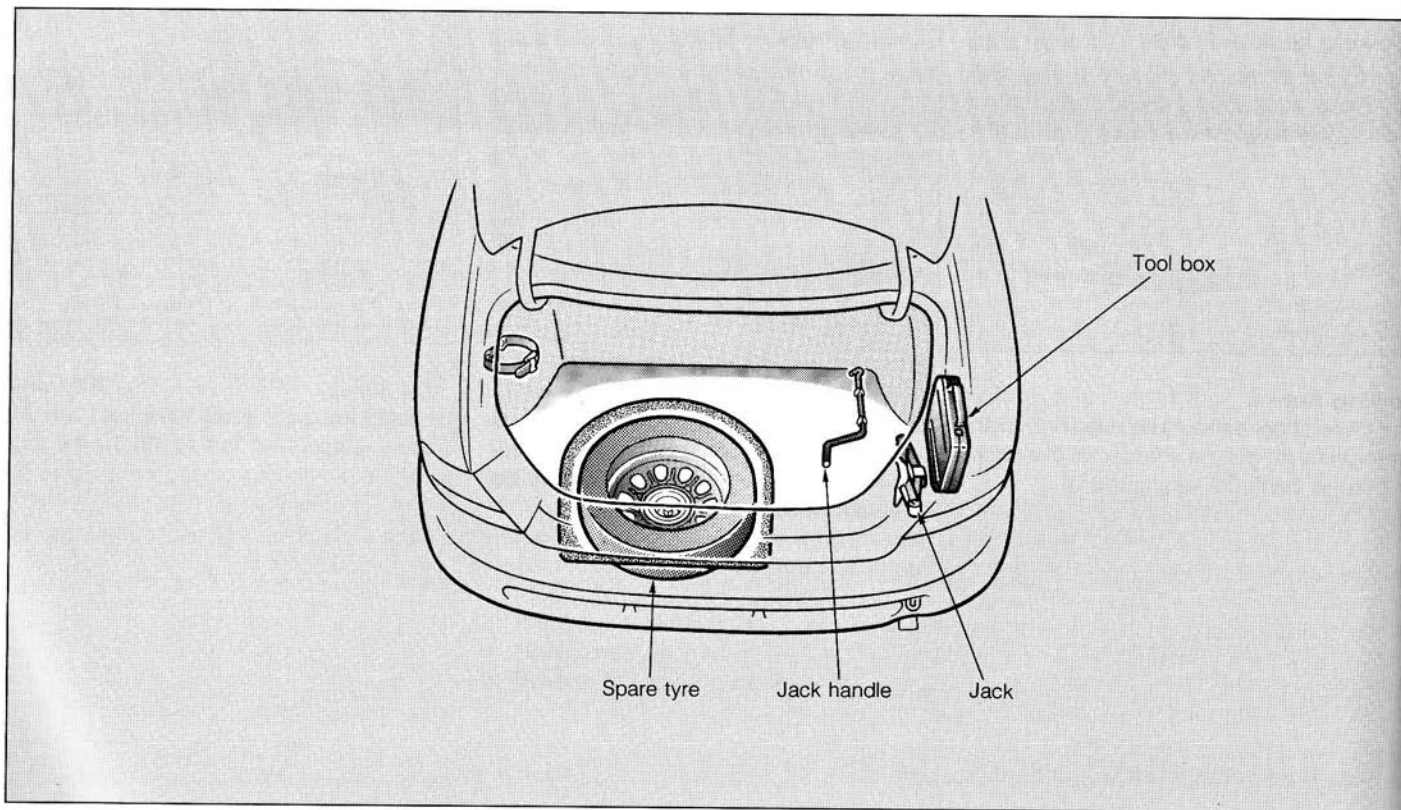



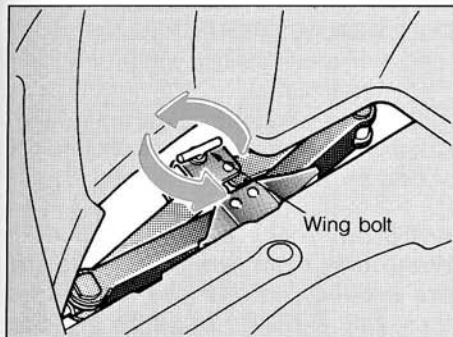

### To remove the jack:

Turn the wing bolt counterclockwise.

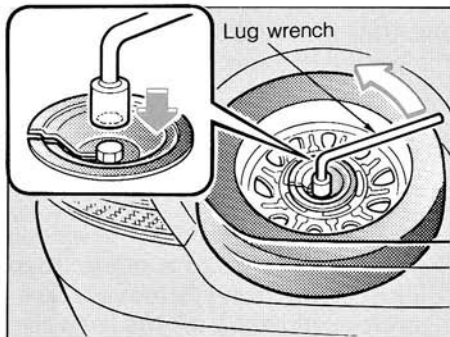

### To remove the spare tyre

1. Turn the tyre hold-down bolt counterclockwise with the lug wrench and remove it.
2. Remove the spare tyre.

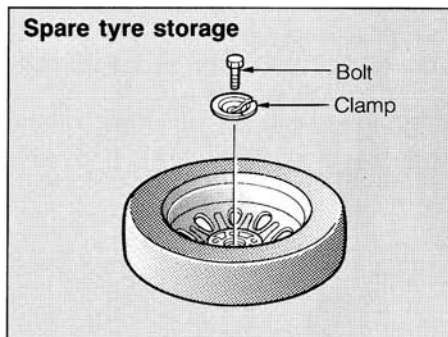

Store jack and tyre in the reverse order of removal.

### NOTE

To prevent the jack, jack handle, and toolbox from rattling while the vehicle is in motion, store them properly.

### Spare Tyre

This is the same type and size of tyre that is mounted on your vehicle as original equipment. It may be used as a spare or as one of the tyres used for the normal tyre rotation.

### Changing Tyres

#### JACKING INSTRUCTIONS

The jack is provided for emergency tyre changing only.

Follow jacking instructions to reduce the possibility of personal injury.

#### WARNING!

- **Never attempt vehicle repairs in the traffic lanes of a public road or highway. Always move the vehicle completely off the road and onto the shoulder before trying to change a tyre. If you cannot find a firm, level place off the road, call a road service company for assistance.**
- **Do not exceed the jack's maximum permissible load: 800 kg (1,760 lbs).**
- **Be sure to use the correct front and rear jacking positions on the vehicle; never use the bumpers or any other part of the vehicle for jack support.**
- **Never get beneath the vehicle while using the jack.**
- **Do not start or run the engine while the vehicle is on the jack.**

#### TYRE REPLACEMENT

1. Park on a level surface and set the parking brake firmly.
2. Set the automatic transaxle in P (Park), or shift the manual transaxle into R (Reverse).

#### WARNING!

**When one front wheel is lifted off the ground, neither the automatic transaxle P (Park) position nor the manual transaxle R (Reverse) position will prevent the vehicle from moving and possibly slipping off the jack, even if these positions are properly engaged. To prevent vehicle movement while changing a tyre, always set the parking brake fully, and always block the wheel diagonally opposite the wheel being changed.**

3. Activate the hazard warning flasher.
4. Remove the lug wrench, jack, jack handle, and spare tyre from the vehicle.

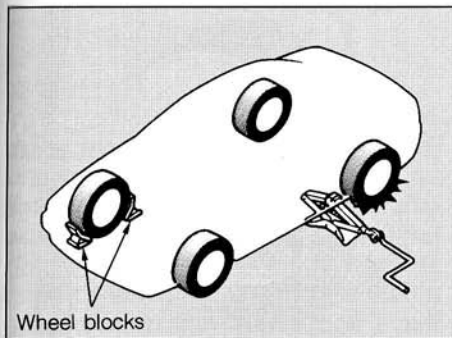

5. Block both the front and rear of the wheel that is diagonally opposite the jack position.

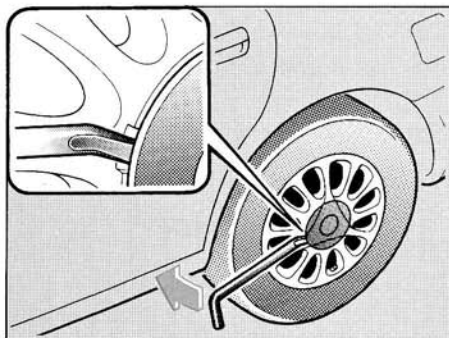

6. If the vehicle has wheel covers or centre caps, pry them off with the bevelled end of the removal tool found in the tool kit.

### NOTE

To prevent scratching the wheel when removing the cover, put a piece of cloth or heavy paper between the tool and the wheel.

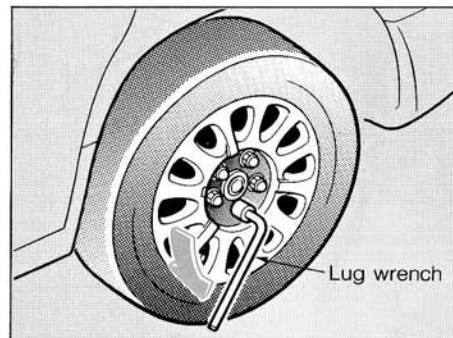

7. Loosen the lug nuts counterclockwise one turn each, but do not remove any nut until the tyre has been raised off the ground.

## IF YOU HAVE A FLAT TYRE

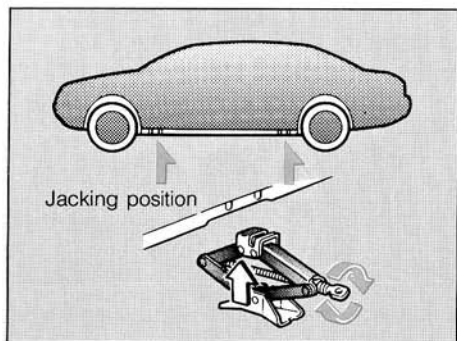

8. Place the jack at the front or rear jacking position closest to the tyre you are changing. Place the jack under the side sill.

### **WARNING!**

**To reduce the possibility of injury, be sure to use only the jack provided with the vehicle and the correct jack position; never use any other part of the vehicle for jack support.**

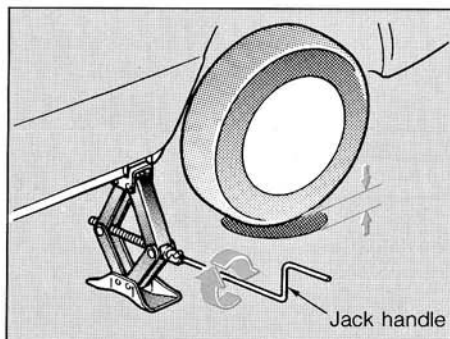

9. Insert the jack handle into the jack and turn it clockwise until the tyre just clears the ground, less than 30mm (1.2 inch). Before removing the lug nuts, make sure the vehicle is stable and that there is no chance for it to slip or move.
10. Remove the lug nuts by turning them counterclockwise, and then remove the wheel.
11. Mount the spare tyre.
12. Install the lug nuts with the beveled edge inward; then tighten them by hand.

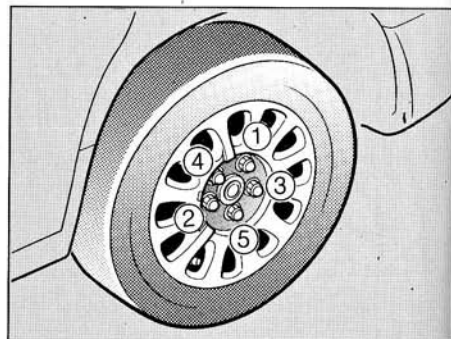

13. Turn the jack handle and lower the vehicle to the ground. Tighten the lug nuts firmly in order as illustrated.

If you are unsure of the tightness of the lug nuts, have them checked at the nearest service station. The specified tightening torque is 88 to 118 N-m (9.0 to 12.0 kgf-m, 65 to 87 lb-ft).

14. Store the removed tyre.

### **WARNING!**

***Your vehicle has metric threads on the wheel studs and nuts. Make certain during wheel removal that the same nuts removed are reinstalled or, if replaced, that nuts with metric threads and the same chamfer configuration are used. Installation of a nonmetric thread nut on a metric stud or vice versa will not properly secure the wheel to the hub and will damage the stud so that it must be replaced. Be sure to use extreme care in checking for thread style before installing aftermarket lug nuts or wheels. If in doubt, consult an Authorized Xedos Dealer. Damaged studs may result in wheel loss and personal injury.***

### **CAUTION**

Check the inflation pressure as soon as possible after installing the spare tyre. Adjust it to the specified pressure (section 9), if necessary.

### **NOTE**

To prevent the jack, jack handle, tool box, and spare tyre from rattling while the vehicle is in motion, store them properly.