

MAZDA RX-7 COMPETITION PREPARATION AND SERVICE MANUAL

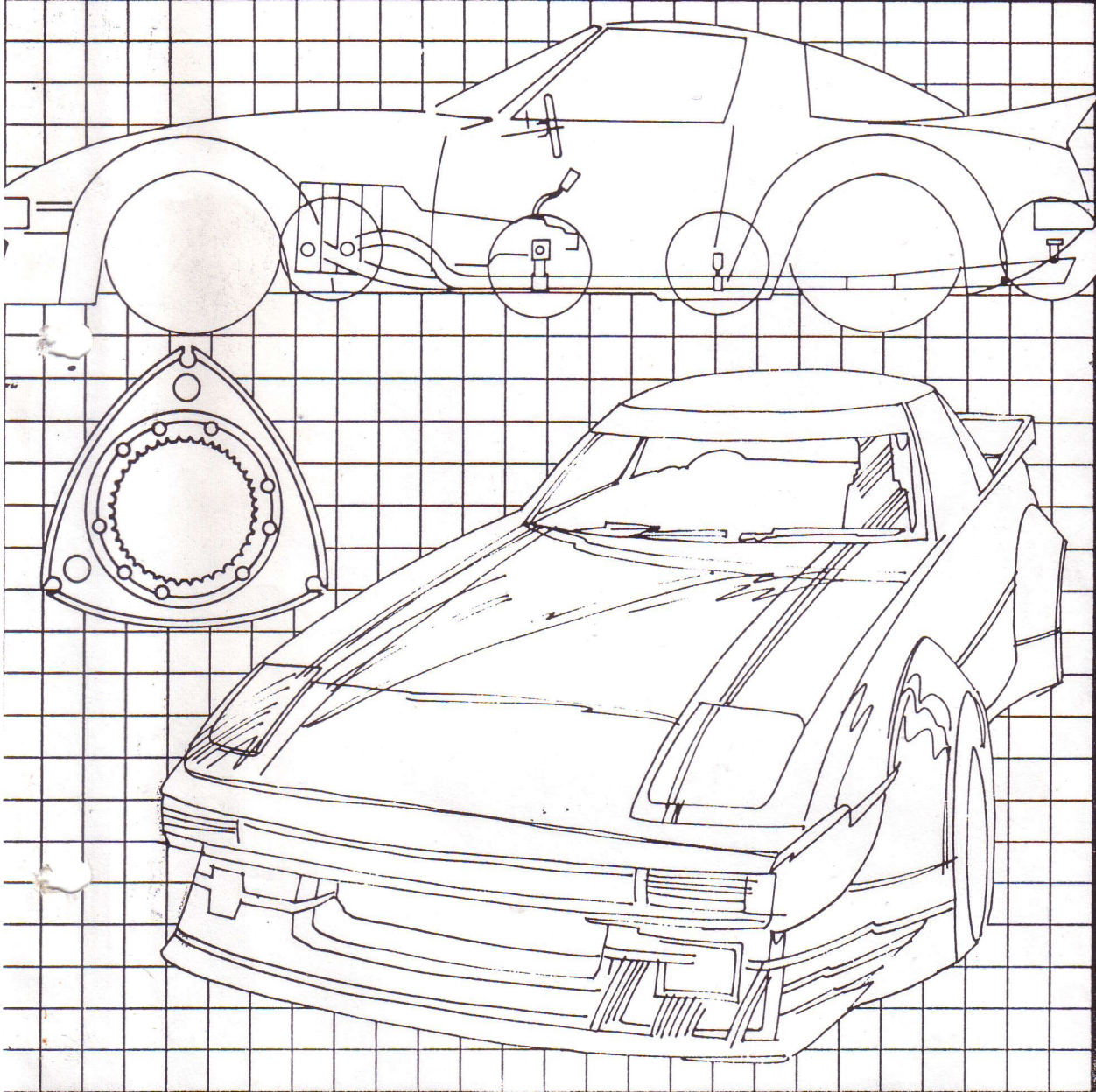

mazda

**MAZDA RX-7
COMPETITION PREPARATION
AND SERVICE MANUAL**

© Copyright 1980 by Toyo Kogyo Co., Ltd.

ENGINE

Basic Specifications

I. Explanation and Description of Competition Parts	5
II. Additional Required Parts	8
III. Machining and Fabrication Operations and Procedures	8
IV. Checks and Measurements	13
V. Assembly Operations	21
VI. Checks and Adjustments	21
VII. Operating Procedures	24

CHASSIS

DRIVELINE

I. Explanation and Description of Competition Parts	27
II. Notes on Machining and Assembly	28
III. Checks, Adjustments and Practices	31

BRAKE SYSTEM

Specifications

I. Explanation and Description of Competition Parts	35
II. Machining Operations	36
III. Checks, Adjustments and Maintenance	37

STEERING AND SUSPENSION

Specifications

I. Explanation and Description of Competition Parts	39
II. Machining and Installation Operations	40
III. Checks, Adjustments and Maintenance	44

APPENDIX

Comparison of Specifications, RX-7 and RX-3	47
---	----

PREFACE

Toyo Kogyo Co., Ltd., wishes to extend appreciation for your interest in and efforts with the Mazda RX-7 in automobile competition. This Manual reflects the knowledge gained by Mazda competitors and Toyo Kogyo engineers through much research, development and actual competition, and is to be considered recommended practice. It is intended for use only by those seriously engaged in the construction and maintenance of the RX-7 in competition; the parts, procedures and specifications outlined within the Manual are for racing and competition use only, and specifically have no relation to or application or other purpose for street and highway-driven automobiles. If the information contained in this Manual is applied to a street or highway-driven RX-7, the results may include voided warranties, reduced reliability, and losses in performance, economy and emissions, all or some of which may be illegal in certain areas and which are definitely not approved by Toyo Kogyo Co., Ltd.

With the parts, procedures and specifications in the Manual the competitor can assemble and maintain the engine, drivetrain and chassis components and the various appropriate subsystems involved in a competition Mazda RX-7. The individual competitor should be aware that many of the parts and procedures outlined in this Manual may not be allowed under the rules and regulations of certain competition organizations, and it is the responsibility of the competitor, racer, mechanic or other person associated with racing a Mazda to have a full understanding of the pertinent rules and regulations of his competition governing body. For instance, the reader will notice there is no section in this Manual on the design and construction of a roll cage structure, as these details and requirements vary with different sanctioning organizations.

In competition there is a high degree of experimentation, and the reader is assumed to understand that such experimentation is on an individual basis, is not covered by this Manual, and from the position of Toyo Kogyo Co., Ltd., and its affiliates, is therefore categorized as non-recommended practice. Toyo Kogyo Co., Ltd. is interested in the results of any competition experimentation or experience, but specifically cannot recommend a new procedure until it has undergone a thorough analysis by appropriate company engineering staff.

In any form of automobile competition the individual is also considered to assume responsibility for his or her actions, and to realize and accept that automobile competition is, by its very nature, a hazardous activity with a high degree of risk of damage to equipment and/or personal injury. By the application of this Manual it is assumed the individual will be operating a competition automobile at or near the outer limits of its performance envelope, and the closer to those limits the greater the risk. Neither Toyo Kogyo Co., Ltd., nor any of their affiliates or employees assume any responsibility in any manner for any losses, either to equipment or persons, resulting from the use of any Mazda automobiles in competition or the application of any parts, procedures or specifications outlined in this Manual.

Finally, automobile competition is a constantly changing area of endeavor, subject to new technology, and this Manual is the current best recommended practice but is subject to change, without notice, at any time.

Again, thank you for your interest in the Mazda RX-7 in automobile competition, and we extend you good luck and best wishes in your efforts.

ENGINE
Basic Specifications

Type	12A Rotary
Displacement, per rotor	573 cc
Displacement, total	1146 cc
Compression ratio	9.4:1
Intake porting	Peripheral
Exhaust porting	Peripheral
Carburetion	Twin throat, down draft Weber
Lubrication	Wet sump
Cooling	Liquid
Ignition	Transistorized, capacitive discharge (CDI)
Maximum allowable engine speed	9,000 RPM

I. Explanation and Description of Competition Parts.

A. Housing group.

1. Rotor housing, 4352 10 100
It has the following differences from the stock housing:
 - (1) The intake porting is peripheral.
 - (2) It is sand cast from lower volume patterns.
 - (3) The coolant passages are different.
 - (4) The trochoid surface is directly chrome plated onto the casting instead of being a sheet metal insert.

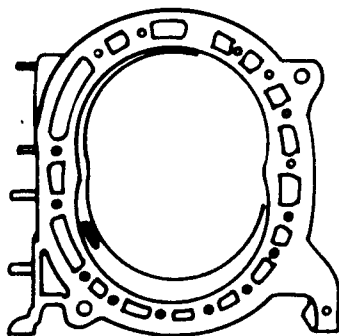

The intake and exhaust timing is as follows:

Intake Opens 86° BTDC Closes 75° ABDC
Exhaust Opens 73° BBDC Closes 65° ATDC

2. Side housings,
front: 4352 10 200
intermediate: 4352 10 400
rear: 4801 10 300

They differ from the stock housings in these ways:

- (1) The intake ports are filled in solid.
- (2) The intermediate housing has an oil separator tank.
- (3) The passages for the oil pump on the front housing are larger passages.

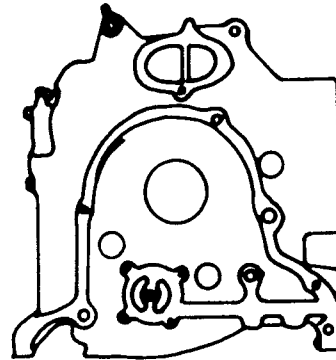

3. Tension bolts, 4352 10 451A
These are the stock bolts with rubber bonded to them which dampens out vibrations at certain frequencies and prolongs bolt life.

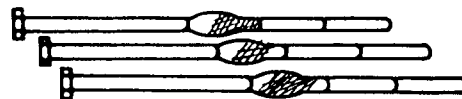

4. Stationary gears,
front: 4352 10 500
rear: 4352 10 550
Compared to the stock gears, these have the following differences:
 - (1) For strength, the material and heat treatment is different.
 - (2) A machined groove around the bearing; this feature enhances bearing life.

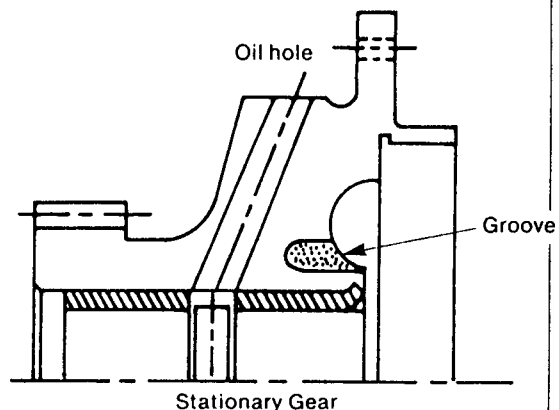

5. Oil pan, 4352 10 700

This is an increased capacity pan to maintain pressure under racing conditions, particularly while cornering.

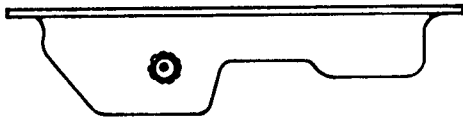

6. Baffle plate, 4352 10 709

This baffle plate will maintain an adequate oil supply around the oil pump pickup while cornering or braking.

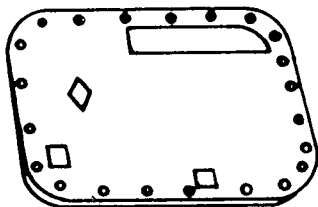

B. Rotating group.

1. Balancer assembly, 4352 11 010

These pieces differ from stock by being balanced to a closer tolerance.



2. Rotor, 4352 11 100

The competition rotor has the following features:

- (1) The combustion chamber is the Medium Deep Recess (MDR) type.
- (2) It has a snap ring to retain the internal gear in place.
- (3) The apex seal groove is chrome plated to reduce wear.

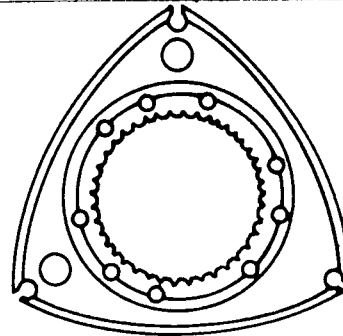

**3. Rotor bearing, standard: 1011 11 111
oversize: 1058 78 135**

The oversize bearing is available to provide the correct oil clearance, and is larger in diameter by 30μ

4. Apex seal, 4352 11 301

The apex seal is made of carbon and is 3.0 mm thick.

5. Apex seal spring, 4352 11 304

This spring is designed specifically for the 3.0 mm carbon apex seal.

6. Side seal, 4801 11 311

Compared to the stock seal, this side seal is molybdenum treated for increased wear resistance.

7. Corner seal, 1881 78 146

The corner seal has a sprayed molybdenum coating for self lubrication properties.

**8. Outer oil seal spring, front: 4352 11 353
rear: 4352 11 363**

The increased pressure of this spring, different from original, 13 kg/cm^2 as compared to 8 kg/cm^2 for the standard oil seal spring, prohibits combustion gas blowby. For the inner oil seal, the stock spring is satisfactory.

9. Eccentric shaft, 4352 11 400

The material and configuration of this shaft are identical to stock, but to reduce the likelihood of bearing seizure, the rear half of the rear main journal is machined 20μ smaller in diameter, as shown in the illustration. ($\Delta D = A - B$)

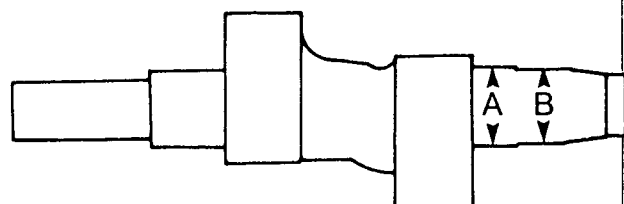

10. Drive pulley, 4352 11 601

This pulley has the following differences from the stock version:

- (1) The material is aluminum alloy to reduce weight and rotating inertia.
- (2) The oil seal lip's contact area has been treated for wear resistance.
- (3) The diameter is 90 mm.

11. Flywheel, 4352 11 755

This flywheel is fabricated from steel but is significantly lighter than stock to reduce rotating inertia.

12. Needle bearing, 0822 78 184

The needle bearing has a higher load capacity to withstand severe clutch engagements.

C. Intake and exhaust group.**1. Intake manifold, 4352 13 100**

This manifold has the following features:

- (1) It is cast from aluminum alloy.
- (2) It has been designed to accept and work with the DDW 48IDA carburetor, and to match an engine installation angle of 4°40'.
- (3) The length of the intake passages has been determined for optimum tuning and efficiency at the designed engine speeds.

**2. Gaskets, rotor housing to intake manifold: 0862 78 205
intake manifold to carburetor: 0862 78 206****3. Carburetor support, 0862 78 240**
This support reduces the transfer of engine vibrations to the carburetor and thereby prevents fuel surging and bubbling.**4. Exhaust header and pipe, header: 4352 78 250
pipe: 4352 78 260**

Some of the main features of this exhaust system are:

- (1) Both the header and pipe are fabricated from stainless steel.
- (2) The header is a tubular design, and the pipe terminates in a megaphone.
- (3) The header and pipe are joined by a sliding connection to allow for engine vibration and

movement.

5. Exhaust system support brackets.
See page 10 for details.**D. Lubrication group.****1. Oil pump, 1058 78 220A**

The shaft and rotors in the competition oil pump are more resistant to wear and seizing.

2. Oil pressure regulator assembly, 4352 14 250

This regulator will maintain oil pressure at 6.5 ± 0.5 kg/cm².

3. Engine oil cooler, 1058 78 180

This larger-than-stock cooler will increase cooling capacity by 50 percent over stock.

E. Cooling group.**1. Water pump, 4801 15 010**

The competition water pump is aluminum alloy.

2. Water pump pulley, 4801 15 151

To reduce weight this pulley is made from aluminum alloy, and its larger-than-stock 130 mm diameter will enhance V-belt life and reduce the speed of the water pump.

3. Radiator, 1058 78 190

The aluminum alloy competition radiator's larger core will increase engine cooling capacity by 60 percent over stock.

4. V-belt, 1058 78 154

This notched V-belt is more resistant to heat, stretch and vibration.

F. Electrical system.**1. Ignition coil, 4801 18 100**

This higher output coil is exclusively designed for use with the Mazda competition capacitive discharge ignition (CDI).

**2. High tension wires, coil-to-distributor: 4352 18 110
distributor-to-spark plugs: 4801 18 150**

These high tension wires have a metal wire core to reduce voltage drop.

3. Distributor, 4801 18 200

These are the main features of the distributor:

- (1) It is breakerless, having a magnetic trigger.
- (2) There is no advance mechanism.

ENGINE

4. Ignitor and lead wiring,
ignitor: 4801 18 800
lead wiring: 4801 18 870
This fully transistorized ignition will provide a stable secondary voltage at high engine speeds. The lead wiring harness is specifically intended for this ignition.
5. Alternator and alternator strap,
alternator: 3997 18 300
strap: 4801 18 361
Alternator pulley part number:
0833-78-153A

The alternator output is 35 amps, and its pulley diameter is 75 mm.

6. Starter stay, 4352 18 401
spacer, 1281 17 383
The starter stay reduces vibration and prevents possible breakage of the transmission case.
Note: When installing the stay, the spacer must be inserted between the stay and the starter motor.

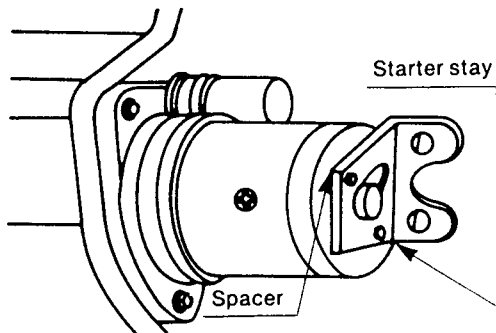

7. Spark plug, 4352 18 600
The heat range of this plug is 11.5, which is colder than stock.
8. Fuel pump, 4352 18 250
This fuel pump has an output of 100 liters/hour. Two of them are needed to satisfy the racing engine's minimum fuel flow requirement of 180 liters/hour.

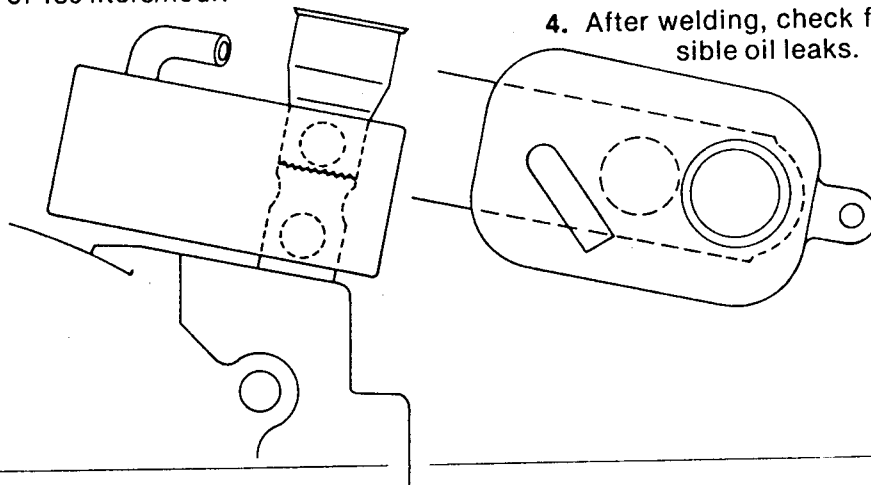

II. Additional Required Parts.

These parts must be acquired from outside sources.

1. Carburetor.
This engine uses a Weber 48IDA of the following specifications:

Bore x Venturi (mm)	48 x 43
Emulsion tube	F-8
Main jet	#230
Main air corrector jet	#130
Idle jet	#80
Idle air corrector jet	#120
Accelerator nozzle	#50
Needle & seat	#300
Float level	21-23 mm from the upper surface of the float chamber.

2. Tachometer.
We recommend using a mechanical tachometer.
3. Temperature gauges.
Minimum requirements include water and oil temperature gauges.
4. Oil pressure gauge.
We recommend a mechanical gauge of the Belden tube type.

III. Machining and Fabrication Operations and Procedures

A. Fabrication of oil separator tank.

1. Use the stock oil filler pipe.
2. The original filler pipe is too long and must have a 40 mm section removed from the middle. Cut it, reweld and drill holes as shown in the illustration.
3. Fabricate the tank as shown, and weld it to the filler pipe.
4. After welding, check for any possible oil leaks.

B. EGR port block-off plate.

1. If your intermediate housing has an EGR port, it must be blocked off with a plate. We recommend aluminum approximately 3.0 mm thick.
2. When installing the block-off plate, use a gasket or some silicone sealant.

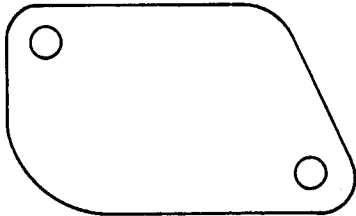
**C. Metering pump hole cover.**

1. If the metering pump shaft is not used as a mechanical tachometer drive, the hole must be covered with a plate. Make the plate of aluminum approximately 3.0 mm thick.
2. A gasket must be used with the hole cover plate.

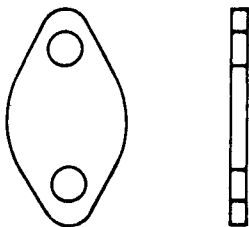
**D. Weber carburetor float bowl extension.**

For courses with very tight or long corners, this float bowl extension will help prevent fuel starvation.

The float bowl extension fabrication procedure is as follows:

- (1) Cut an appropriate hole on the side of the float chamber.
- (2) Fabricate the bowl extension from sheet aluminum as shown in the illustration.
- (3) Weld the bowl extension to the float chamber at four points only; if you weld all around the carburetor may distort.
- (4) After welding, seal the bowl extension to the float chamber with Three Loy. The Three Loy may be held in place with clay or something similar until it hardens.

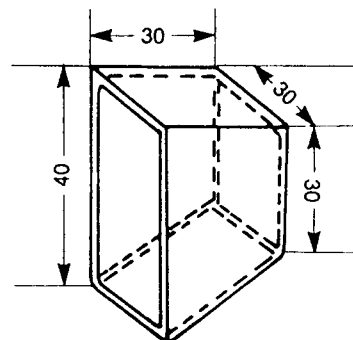
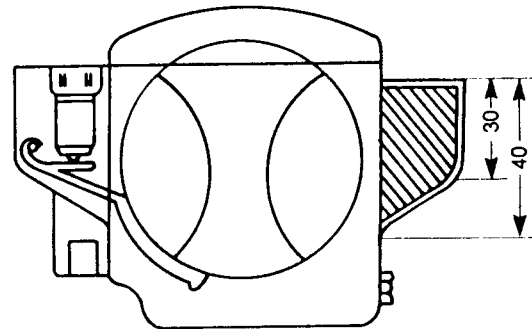

E. Exhaust System Mounting
Exhaust pipe

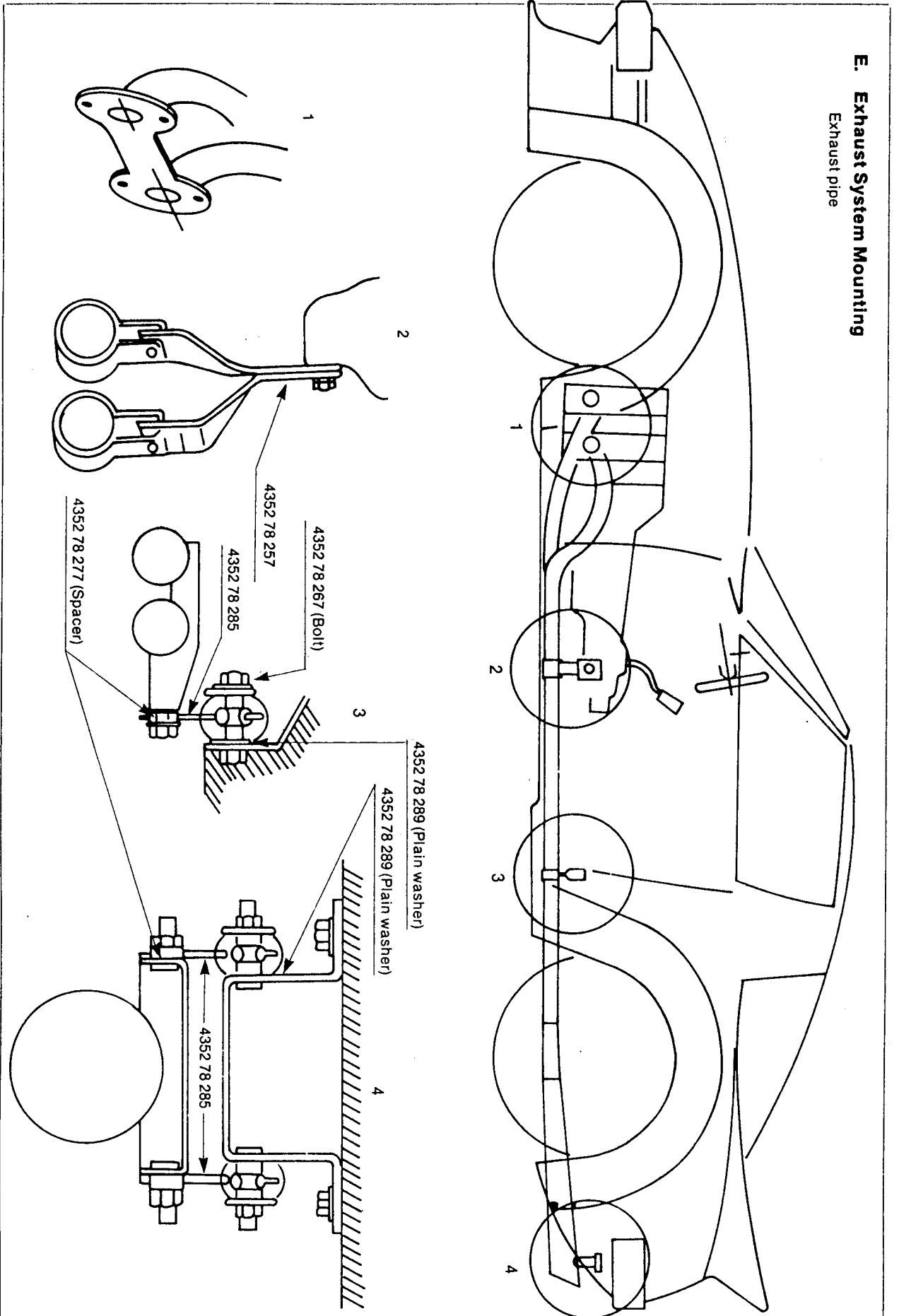

F. Cold air induction box.

This is one of the best ways we have found to utilize the high pressure area at the front of the car for intake air, but its size, location and design are important to maximum performance. The important points of its design are outlined below.

5. Fabricate the intake section to the dimensions shown, and attach to right side panel as shown in the illustration.

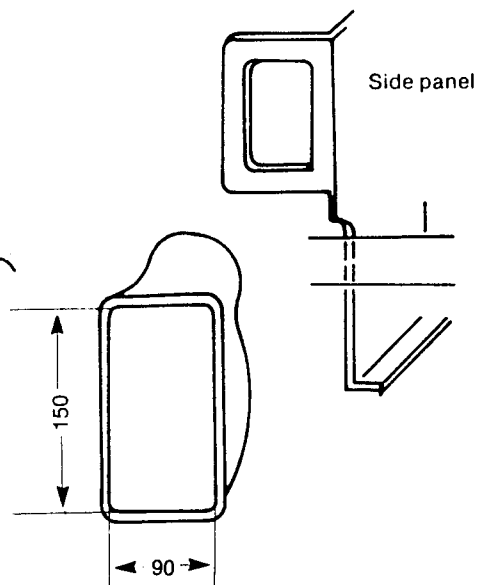
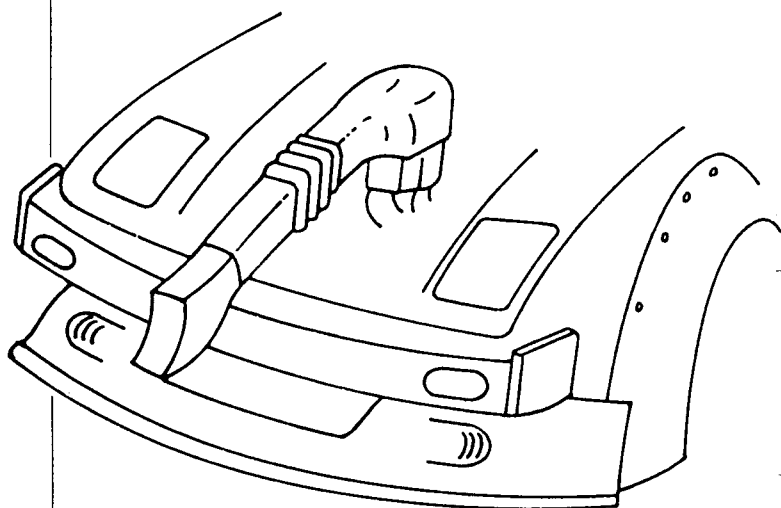

1. The air intake section should be located in the right hand side of the radiator opening.
2. We recommend fabricating the air intake and carburetor cold air box from fiberglass.
3. The design of the carburetor cold air box is shown below:

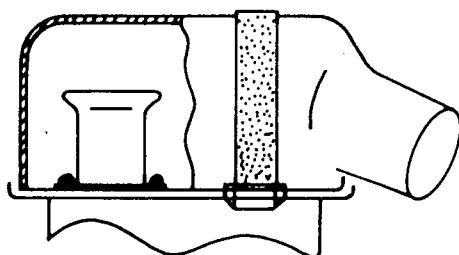

6. An air filter element is absolutely necessary. If dirt gets into the engine through the intake, compression is lost from wear on the internal gas seals. For a filter element material, Filtron has worked very well. Locate the element at the entrance to the carburetor cold air box. The intake system should be sealed very tight to completely prohibit any dirt or dust from entering the engine, so check for air leaks, holes or other openings.

4. The connecting duct can be any type of flexible hose with a minimum diameter of 110-120 mm.

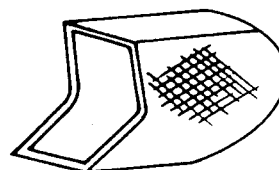
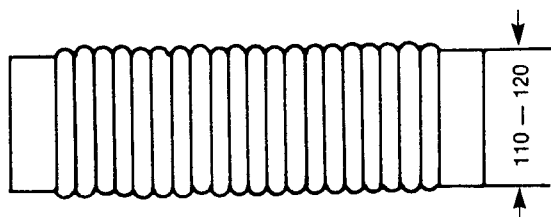

G. Competition radiator installation.

1. Fabricate the left and right side panels as shown in the illustrations below. All dimensions are given in millimeters. The hole in the right side panel is for the intake system.

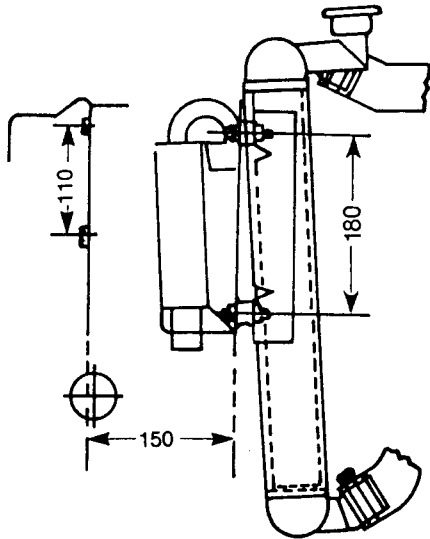

2. Install the side panels in the same location and manner as the stock versions.

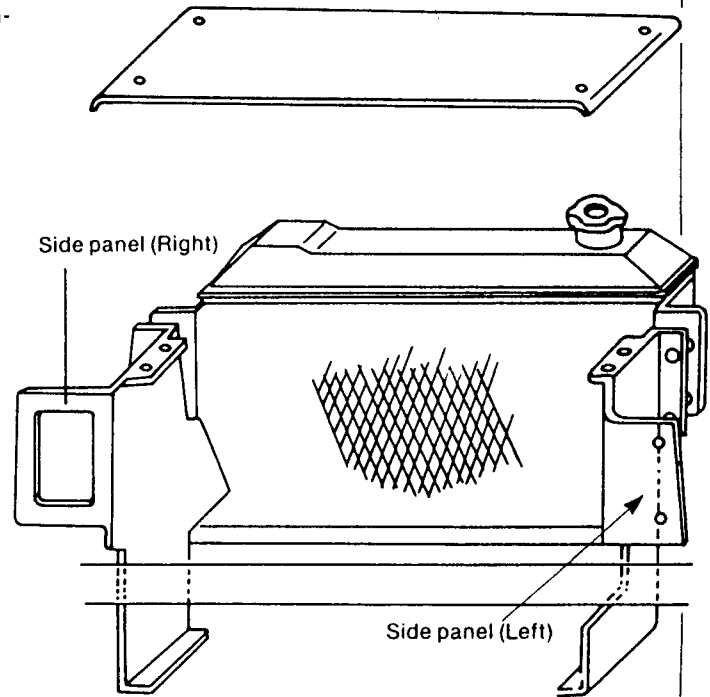

H. Competition oil cooler installation.

There are two possible locations for the oil cooler as shown in the illustrations below. In both cases, the competition oil cooler hoses can be used, in either the vertical-type or horizontal-type mounting.

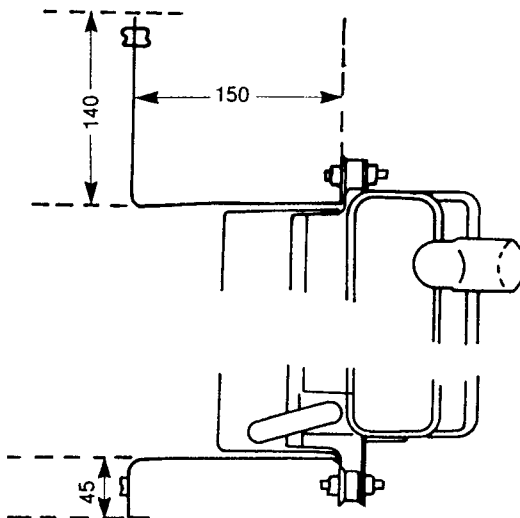

Vertical type

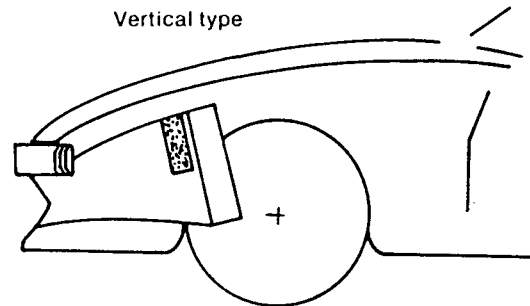

Horizontal type

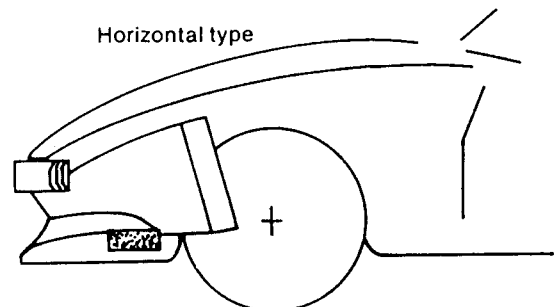

1. The first location is referred to as the vertical-type, with the oil cooler mounted in front of the radiator and attached to the radiator support brackets with rubber mounts.
2. The second location is referred to as the horizontal-type and is superior to the vertical-type, as it effectively lowers the oil temperature by approximately 18° F (10° C).
 - (1) The installation of the oil cooler in the horizontal location requires fabrication of mounting brackets as shown in the illustration.
 - (2) Install the brackets by utilizing the bumper bracket bolts, as shown in the illustration.

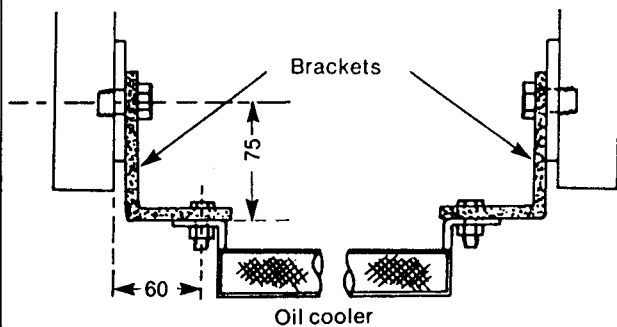
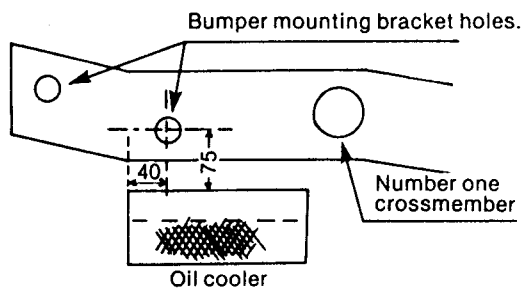

Note: All dimensions are in mm.

IV. Checks and Measurements.

A. Side housing.

1. Checks (to be done before cleaning).
 - (1) In the area where the side housing contacts and mates with the rotor housing, check all around the coolant passages for signs of coolant or gas leakage or surface abrasion.
 - (2) On the rubbing surface, check for excessive wear or scuffing on or in the paths traced by the rotor seals.
2. Cleaning.
Clean off any surface deposits with MEK or paint thinner. If the

deposits are resistant to cleaning with either of these solvents, use #400-#600 sandpaper wetted with oil.

3. Measurements.

- (1) Surface flatness (side housing distortion).
 - a) To check surface flatness use an accurate straight edge and a set of feeler gauges.
 - b) Check the surface in the four locations shown in Figure 1. The limit for distortion is 0.04 mm, and if this limit is exceeded at any point, the side housing must be replaced.

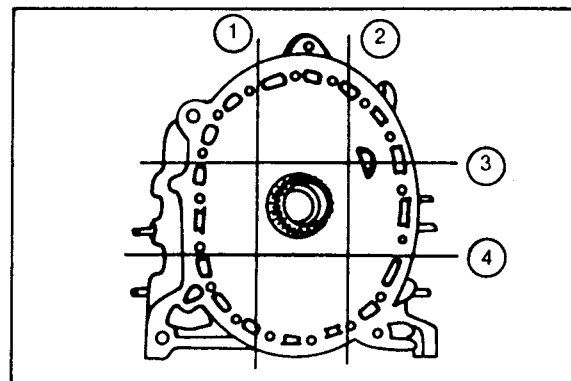

Figure 1

- (2) Stepped wear from side seal.
 - a) To check the side seal wear, use a dial indicator with a sharp tip and a suitable dial indicator stand, and check as shown in Figure 2.

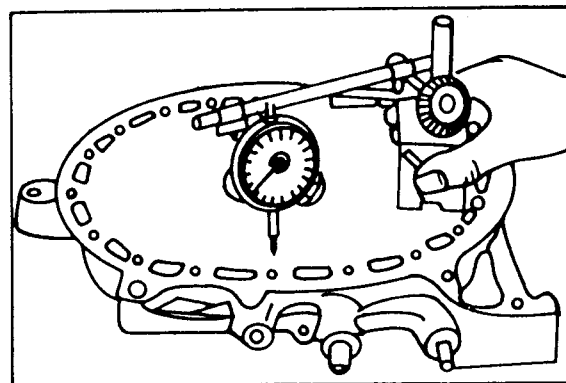

Figure 2

- b) The allowable limit for wear is 0.1 mm, and if this limit is exceeded, the side housing must be replaced.

Note:

- a) Pay particular attention to the spark plug side of the side housing; this is the combustion area and is usually the location of the greatest wear.
- b) If excessive wear rates are measured over a relatively short period of time, for instance 0.1 mm after 2000 miles or less, it may be an indication of dirt or other contaminants in the engine and the intake air filtering system should be checked.

B. Stationary gears (front and rear).

1. Checks.

Visually, check for any indications of damage or cracking on the teeth.

2. Measurements.

(1) Inside diameter of bearing.

- a) With an inside micrometer, measure the four points as shown in Figures 3 and 4.

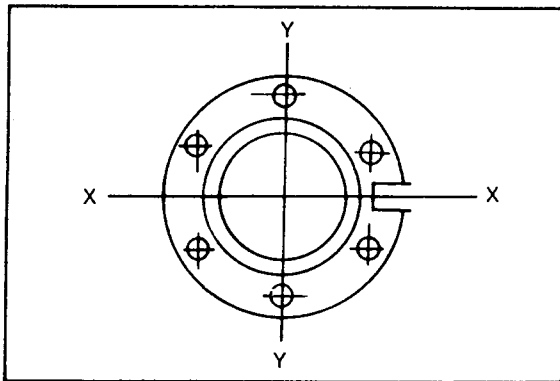

Figure 3

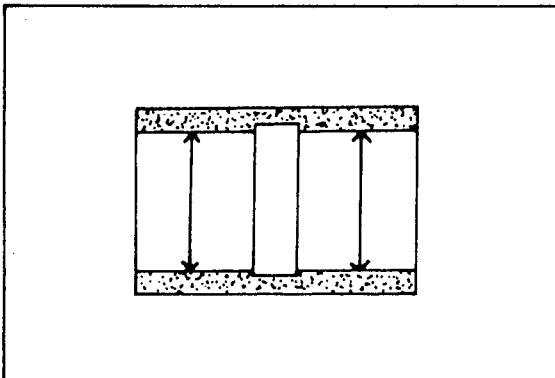

Figure 4

If the oil clearance is incorrect or the surface is flaking, the bearing must be replaced.

(2) Oil clearance calculation.

Determine the oil clearance by the following formula:

$$A = (\text{Min. inside dia.}) - (\text{Max. dia. of journal})$$

$$B = (\text{Max. inside dia.}) - (\text{Min. dia. of journal})$$

Both the A and B dimensions must be in the range of 0.05-0.08 mm.

3. Bearing replacement.

(1) Bearing removal.

To remove the bearing, use a press and the bearing puller, part number 49 0813 235. Remove the adaptor ring from the puller, and press from the gear side as shown in Figure 5.

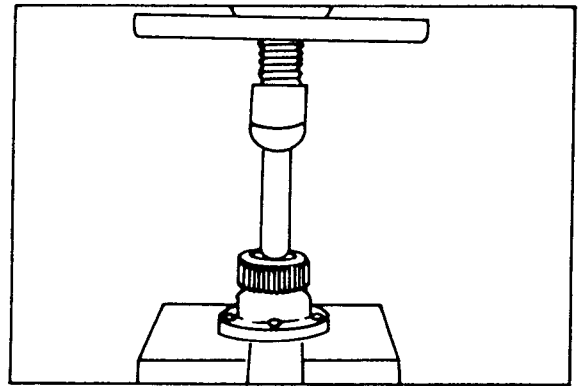

Figure 5

(2) Bearing installation.

Pay particularly close attention to the positioning of the clinch lock section of the bearing.

Install the bearing with this procedure.

- a) Attach the adaptor ring to the press tool.
- b) Make certain the clinch lock is in the proper position.
- c) Press the bearing all the way down until the adaptor ring contacts the gear flange, as shown in Figure 6.

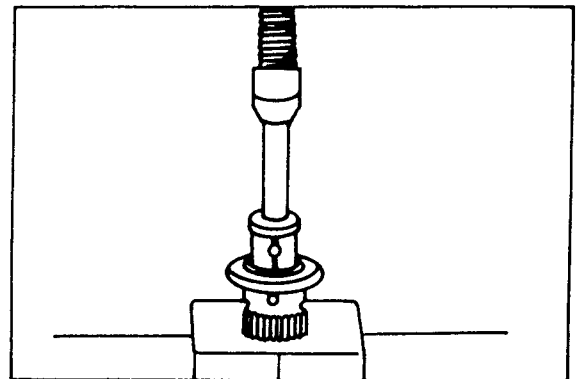

Figure 6

C. Measurement of ΔF (ΔF is the smallest clearance between the rotor and the rotor housing surface).

- (1) Install outer oil seals and springs in one side of the rotor. This will prevent the rotor contacting and thus scuffing the side housing as you rotate it for measurement.
- (2) Invert the rotor and insert it in the rotor housing. The springs will hold the oil seals in place.
- (3) Measure ΔF with a feeler gauge, as shown in Figure 7. There are four measuring points, two on each side, at 25 mm above and below the horizontal centerline, as shown in Figure 8.

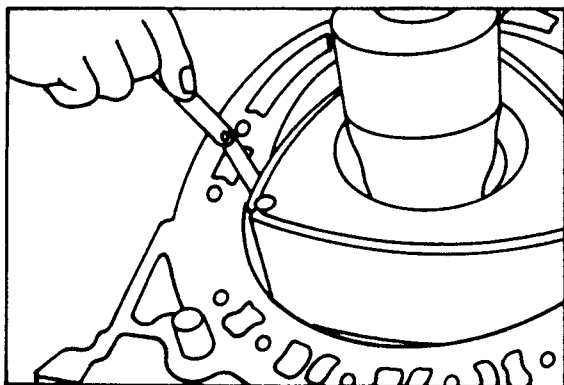

Figure 7

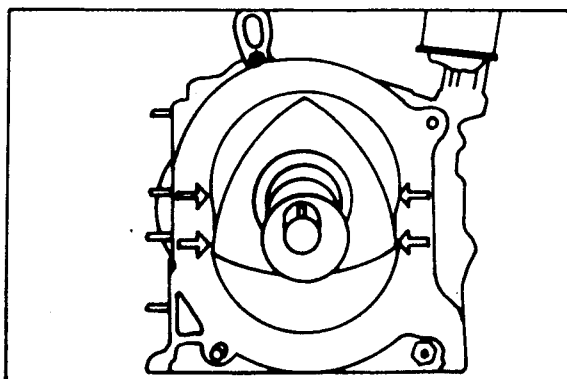

Figure 8

The allowable clearance range for ΔF is 0.40-0.70 mm.

Notes:

- a) If ΔF is less than 0.40 mm, the rotor may contact the housing at high speed.
- b) Mark F or R, for front or rear, on the rotors after measuring for ΔF .
- c) Use care not to damage the interior surface of the rotor housing with the feeler gauge.

D. Rotor housing (front and rear).

1. Checks (to be done before cleaning).

- (1) Trochoid surface.
 - a) Check the surface for flaking of the chrome plate or dents, scratches or other imperfections.
 - b) Check for gas leakage or deposits.
 - c) Check the trailing spark plug hole for cracks, as shown in Figure 9.

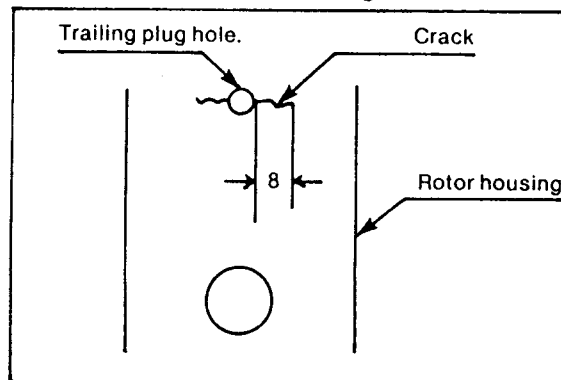

Figure 9

The maximum allowance for cracks is 8 mm; if longer than that, replace the housing.

(2) Rotor housing sides, front and rear.

Check for any indications of gas or coolant leakage, or for any abnormal abrasions. If any of these conditions exist, determine the cause before proceeding.

2. Cleaning.

- (1) Clean carbon or any other deposits with MEK or paint thinner.
- (2) Remove all scale and rust from the coolant passages and water jackets.

3. Measurement of width.

- a) This measurement requires a 50-75 mm micrometer.
- b) Measure the width, or thickness, of the housing at points A, B, C and D as shown in Figure 10. Points C and D are each 20 mm steps, individually beginning at point B. Compare the dimension at point A with the smallest of the other three, whichever it is. If the difference is more than 0.06 mm, the housing must be replaced.

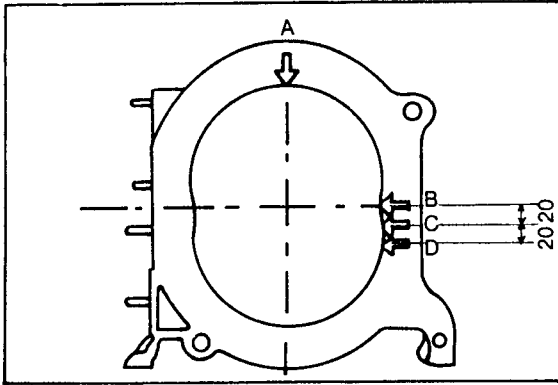

Figure 10

Note: The measuring point for the micrometer is on the inner side of the rubber seal groove. After measuring, mark the housing F or R to denote the front and rear sides.

E. Rotor.

1. Checks (to be done before cleaning).

- (1) Rotor condition.
Check for gas leakage, any damage to the rotor, and the state of combustion. Finally, check for any marks that would indicate the rotor had been contacting the side of the housing; these marks may be found, in particular, in the area of the tip of the rotor.
- (2) Internal gear.
Check carefully for cracks, extreme abrasions, dents, nicks and scratches and other damage to the gear and teeth. (Cracks will sometimes appear around the spring pin hole and in the spring pin itself.)

2. Cleaning.

When cleaning the rotor, do not use a stone, sandpaper, any tool or abrasives to remove carbon from the apex seal groove. This

Figure 11

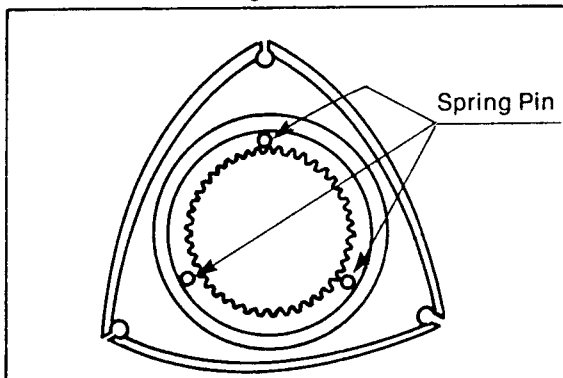

groove should be cleaned only with a brush and kerosene or MEK.

3. Measurements.

- (1) Using a 50-75 mm micrometer, measure the rotor at the three points shown in Figure 11.
- (2) Calculate ΔR by the following formula:

$$\Delta R = (\text{Rotor housing width at point A}) - (\text{Max. rotor width at any point measured in this step})$$

The allowable range of ΔR is 0.13-0.17 mm.

- (3) Measurement of ΔH .
This measurement requires a straightedge and a set of feeler gauges. Check it as shown in Figure 12. The allowable range of ΔH is 0.15-0.20 mm.

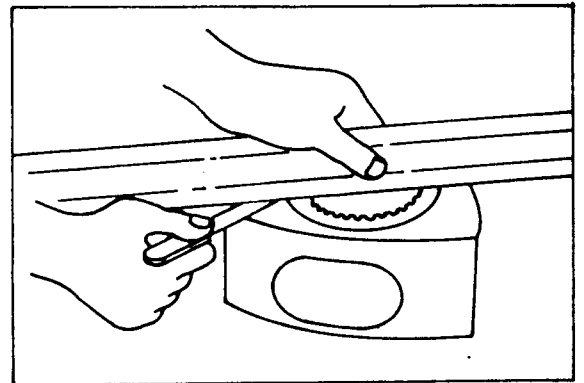

Figure 12

F. Rotor bearing.

1. Checks.

Look for abnormal abrasions or any signs of flaking or seizing.

2. Measurements.

- (1) Measure the bearing with the following procedure:
 - a) Use an inside micrometer and measure the bearing at the six (6) positions shown in Figures 13 and 14.

Figure 13

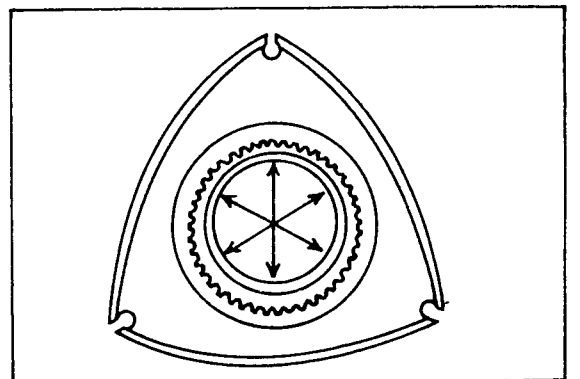

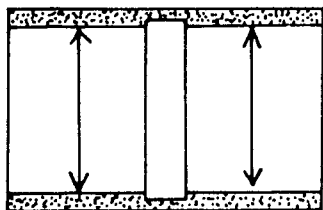

Figure 14

b) The bearing must be replaced if flaking is evident over one-half of its total area or if the oil clearances are incorrect.

(2) Calculate the oil clearance by the following formula:

Oil clearance A = (Min. inside dia.) - (Max. journal dia.)

Oil clearance B = (Max. inside dia. - (Min. journal dia.)

The allowable range of clearances is 0.07-0.10 mm.

Note: There is an oversize bearing available, part number 1058 78 135, if the standard size will not give the proper clearances.

3. Bearing replacement.

(1) Bearing removal.

- Drill out the locking screw with a 7 mm drill.
- Use the special tool, 49 0813 240, to press out the bearing.

Notes:

- Before pressing out the bearing, remove the adaptor ring.
- Press from the side opposite the gear, as shown in Figure 15.

Figure 15

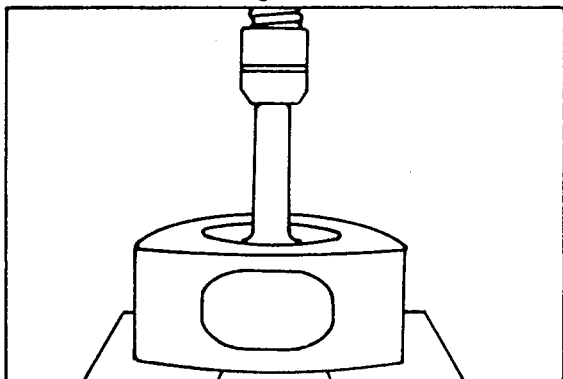

- After removing the bearing, clean the mating surface of the rotor.
- (2) Bearing installation.
- First, install the adaptor ring on the press tool.
 - Press from the internal gear side.
 - Make certain the clinch lock is properly positioned.
 - Press all the way down until the adaptor ring contacts the bearing boss, as shown in Figure 16.

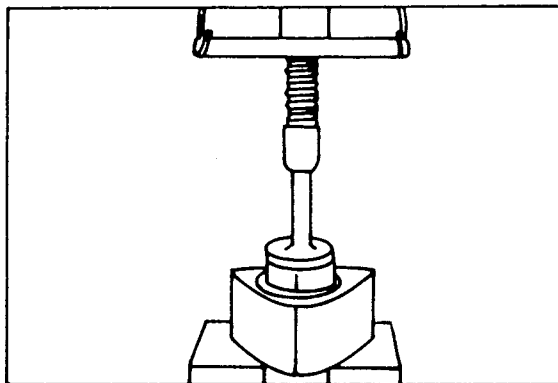

Figure 16

(3) Locking screw installation.

- The bearing should be locked firmly in place by one locking screw opposite the clinch, as shown in Figure 17. This requires drilling and tapping.

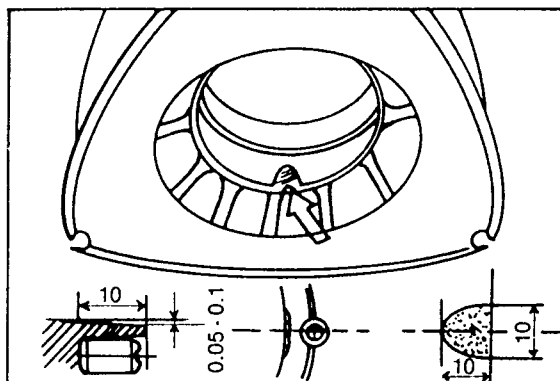

Figure 17

- Before drilling, use the special expander tool to prevent the bearing from deforming.
- Drill a 3.5 mm hole to a depth of 8 mm.
- Cut the thread with an M4-0.7 tap and blow the hole clean with compressed air.
- Insert and tighten the screw and clinch.

- f) Slightly scrape and smooth the surface over the screw.
- g) Clean the rotor thoroughly with kerosene and blow clean and dry with air.

G. Apex seal.

1. Checks.

Basically, the seal should be visually checked for wear, chipping in the groove, cracks, and any other irregularities.

2. Cleaning.

Remove the carbon with MEK or paint thinner.

3. Measurements.

- (1) Measure height, length and width as shown in Figure 18. This will require two micrometers, a 0-25 mm and a 50-75 mm. Mark each apex seal to denote its position and location on the rotor. Measure as follows:
 - a) Height A at both ends.
 - b) Length B at one point.
 - c) Width C at both ends.

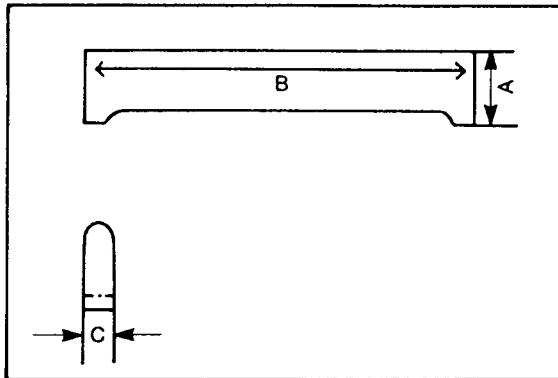

Figure 18

- (2) Measurement of ΔS , the clearance between the apex seal and the side housing.

- a) This measurement requires a 50-75 mm micrometer.
- b) Calculate ΔS by the following formula:

$$\Delta S = (\text{Rotor housing width at point A}) - (\text{Apex seal length})$$

The allowable range of ΔS is 0.10 ± 0.01 mm.

Note: The rebuildable limit of ΔS is 0.15 mm.

- (3) Adjusting ΔS .

If ΔS is less than the lower limit of the allowance, it can be adjusted by sanding the end of the apex seal with #400-#600 sandpaper, as shown in Figure 19.

Note: Be careful not to remove too much material from the apex seal, thereby increasing the clearance over limits which would necessitate replacing the seal.

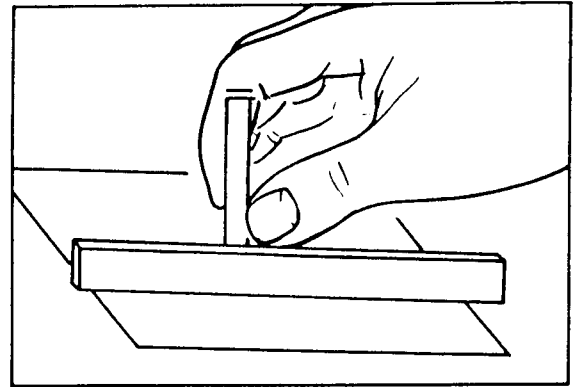

Figure 19

- (4) Measurement of ΔG , the gap between the apex seal and the apex seal groove.

This measurement requires a feeler gauge, and is done as shown in Figure 20.

The allowable limit of ΔG is 0.065 ± 0.005 mm.

Note: If ΔG is in the range of 0.06-0.07 mm, the 0.06 gauge will easily fit into the groove; the 0.07 gauge will be very tight.

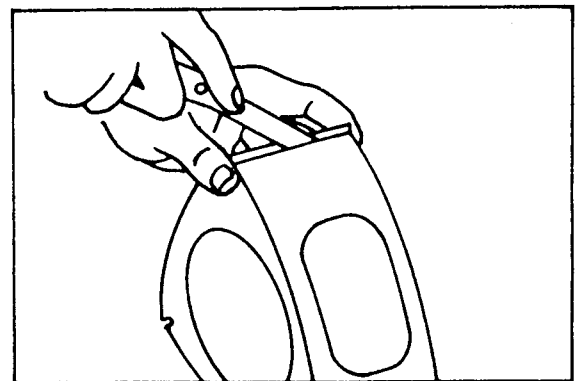

Figure 20

(5) Adjusting ΔG .

If the clearance is less than the allowable range, sand off the apex seal using #400-#600 sandpaper on a known flat, smooth surface as shown in Figure 21. While doing this, the seal should be measured often to prevent removing too much material.

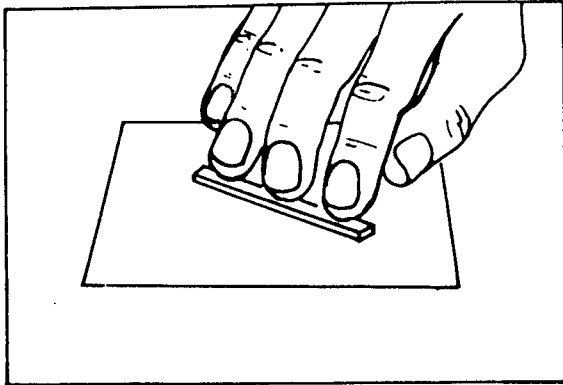

Figure 21

H. Corner seal.**1. Inspection.**

The corner seal should be inspected for cracks or any signs of excessive wear.

2. Cleaning.

Use MEK or paint thinner to remove all carbon deposits, then wipe clean with a cloth dipped in the same solution.

Note: Do not use sandpaper.

3. Measurement.

(1) Measure the height and diameter of the corner seal as shown in Figure 22.

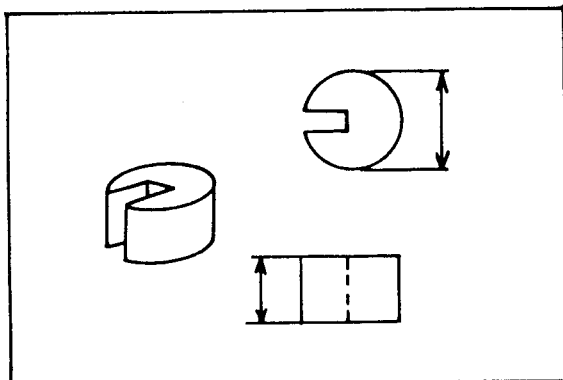

Figure 22

(2) Using an inside micrometer, measure the inside of the corner seal groove as shown in Figure 23.

(3) Calculation of ΔC (the clearance between the corner seal and the groove).

$$\Delta C = (\text{Inside dia. of groove}) - (\text{Corner seal dia.})$$

The allowable range of ΔC is 0.02-0.048 mm.

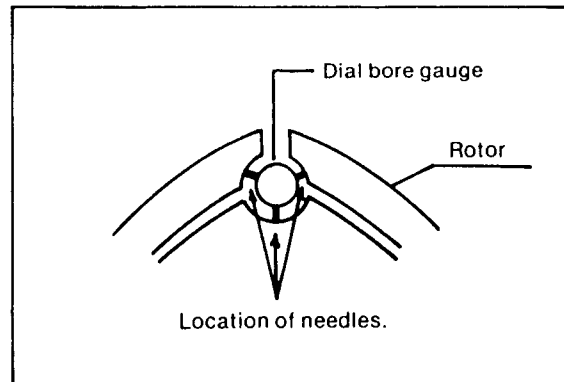

Figure 23

I. Side Seal.**1. Inspection.**

Check the side seal for wear and damage.

2. Cleaning.

Remove all carbon deposits using MEK or paint thinner, then wipe clean with a cloth soaked in the same solution.

3. Measurement.

(1) Measurement of ΔE (clearance between a corner seal and a side seal).

Measure ΔE with a feeler gauge as shown in Figure 24. The allowable range of ΔE is 0.05-0.15 mm, but there is a maximum upper limit for rebuilds of 0.20 mm.

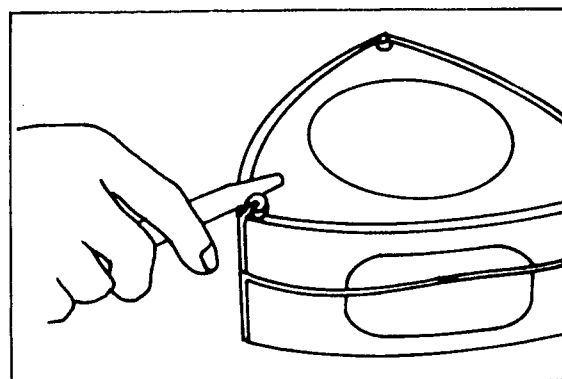

Figure 24

(2) Adjusting ΔE .

ΔE is adjusted by removing metal from the ends of the side seal. The ideal method is to use a rotary grinder, with the stone the same diameter as the corner seal. However, an acceptable and more common method is as described below and shown in Figure 25.

- a) Use a flat file.
- b) File the end of the side seal so its end will fit the corner seal; this angle should be identical to the original angle on the side seal.

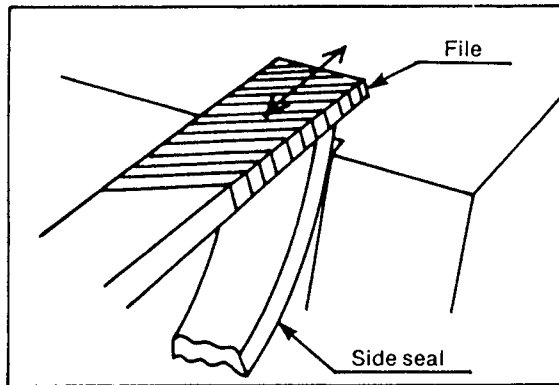

Figure 25

(3) Points to remember:

- a) Use care not to bend or otherwise alter the curve in the side seal; the curve should match that of the groove.
- b) If quite a bit of material needs to be removed, you should first cut the seal, then file to its final shape, to avoid bending or otherwise damaging the seal.
- c) After finishing fitting each side seal, mark it to correspond to its particular groove on the rotor for later assembly.

J. Checking the seal stroke.

The seal stroke is defined as the available travel of a seal spring in its groove, and is a function of the seal spring.

1. To measure the free height of the apex seal spring, place the spring on a level surface and measure it with a scale or vernier caliper as shown in Figure 26.

The lower limit is 3.5 mm.

Note: For these purposes, the seal stroke is the same as the free

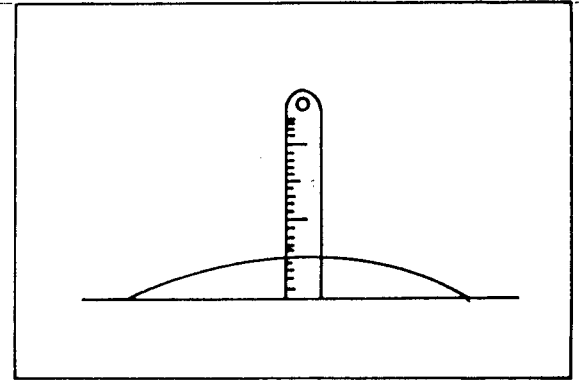

Figure 26

height of the spring.

2. To check the seal stroke of the side, corner and oil seals, use a vernier caliper. Each seal should have a minimum seal stroke of 0.5 mm.

Note: Check each seal to confirm that it will move up and down smoothly in its groove with finger pressure.

K. Eccentric shaft.

1. Inspection.

- (1) Journal. Make a visual inspection for scratches, nicks, scuffing or any other abnormal signs of damage.
- (2) Oil gallery. Check the oil gallery for metal chips, particles or any other contaminants, and blow it clear with air.
- (3) Blind plug. Check to make sure it is tight, as a loose plug will allow oil leakage.
- (4) Needle bearing. Check the needle bearing by inserting its matching transmission input shaft and noting the fit. Look for any damage to the oil seal.

2. Measurement.

- (1) Measurement of the eccentric shaft journal diameter.

On each journal, measure across it in two directions, X and Y, as shown in Figure 27. Measure each journal in this way at four points along its axis. Judge the shaft's condition by any signs of abnormal wear or excessive oil clearance.

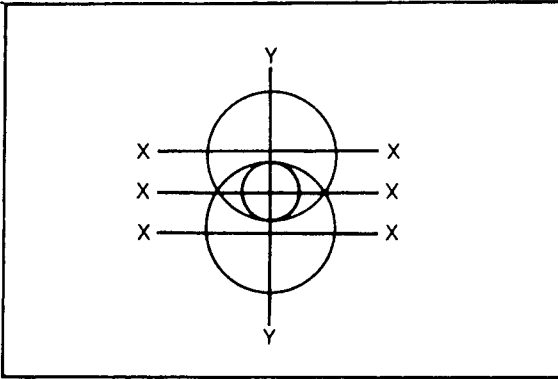

Figure 27

(2) Measuring run-out.

This measurement will require V-blocks, a dial indicator and stand and a flat surface. Measure as shown in Figure 28.

The allowable limit for run-out is 0.1 mm. If that limit is exceeded, the shaft must be replaced.

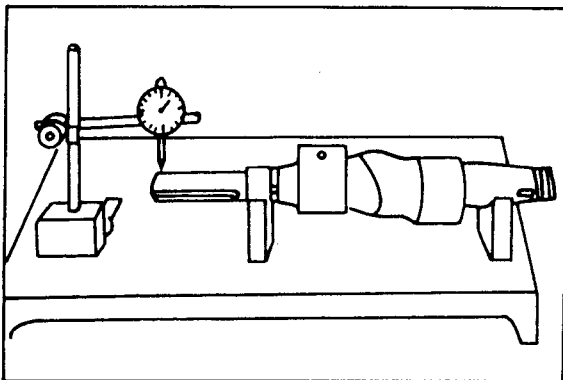

Figure 28

V. Assembly Operations.

A. Engine assembly.

The assembly procedure for the race engine is, for all practical purposes, the same as for the stock engine. However, remember to be aware of any unique procedures required as a result of different parts than the stock version.

B. Points to remember:

- (1) Use engine oil on all moving parts and surfaces during assembly to avoid metal-to-metal contact.
- (2) Use new gaskets, O-rings and lock washers with each rebuild.
- (3) Use two oil pan gaskets. One goes on the upper side of the baffle plate, the other on the lower side.

C. Tightening torques, in kg-m.

ITEM	TORQUE
Tension bolts	3.5
Drive pulley	10-12
Locknut (centerweight)	40-50
Flywheel	3.7-5.5
Front cover	1.6-2.3
Stationary gear	1.6-2.3
Oil pan	0.7-1.0
Water pump	1.6-2.3
Water pump pulley	0.7-1.0
Pressure regulator	3-4
Spark plug	1.2-1.8
Intake manifold	1.6-2.3
Exhaust manifold	4.4-5.9
Pressure plate	1.8-2.7

VI. Checks and Adjustments

A. Fuel system.

1. Carburetor specifications.

- (1) Due to its effect on engine performance, the fuel level should be checked regularly.
- (2) Adjustment procedure.
The fuel level should be checked while the engine is idling. Attach a section of clear neoprene tubing to the drain plug hole, and read the level with a scale as shown in Figure 29.

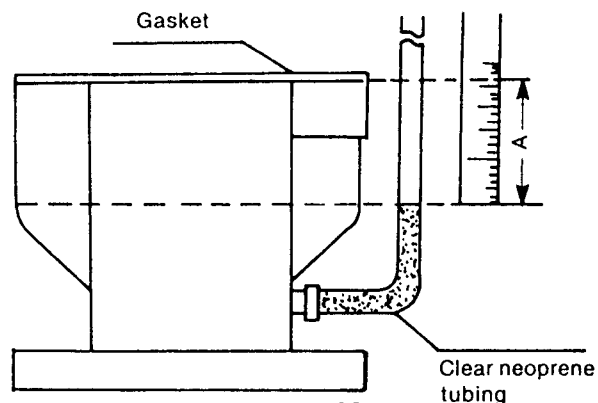



Figure 29

The allowable range for the "A" dimension is 21-23 mm.

If adjustment is required, either bend the float lever arm or change the number of shims on the needle valve nipple.

ENGINE

Check List Of Clearances And Tolerances

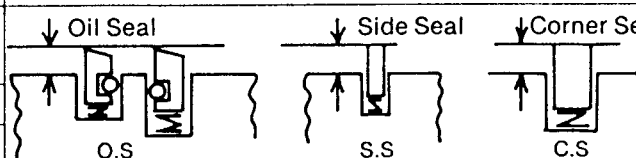
	ITEM	DESCRIPTION	VALUE (mm)
Rotors and seals	ΔF	Minimum clearance, rotor to rotor housing	0.40-0.70
	ΔR	Rotor housing width – rotor width	0.13-0.17
	ΔH	Height of rotor land	0.15-0.20
	ΔG	Clearance between apex seal and groove	0.065 ± 0.005
	ΔS	Rotor housing width – apex seal length	0.10 ± 0.01
	ΔC	Clearance between corner seal and groove	0.02-0.048
	ΔE	Clearance between corner seal and side seal	0.10 ± 0.05
Seal springs	Apex seal		More than 3.5
	Corner seal		Stroke more than 0.5
	Side seal		
	Oil seal		
Bearings	Rotor bearing oil clearance	A = (Bearing min. dia.) – (Journal max. dia.) B = (Bearing max. dia.) – (Journal min. dia.)	
	Main bearing oil clearance	A = (Bearing min. dia.) – (Journal max. dia.) B = (Bearing max. dia.) – (Journal min. dia.)	0.05-0.08
	End play		0.04-0.07
Housings	Rotor housing	Shrinkage (between dimension A and B, C, or D)	0.06
	Side housing	Surface distortion	0.04
		Side seal stepped wear	0.10
Engine tune	Timing	At idle speed	T = 20° (BTDC) L = 20° (BTDC)
	Idle RPM		1000-1500 RPM
	V-belt tension	Deflection equidistant between water pump and alternator	10 ± 1
Oil pump	Tip clearance		0.07-0.10

2. Fuel pump.

Both the fuel pump and relay should be mounted in rubber to minimize vibrations, and the fuel pump must be installed upright, in a vertical position, to function properly. The fuel line should be 7-8 mm inside diameter, arranged to be as short as possible and routed to avoid any high temperature areas; if rubber hose is used for lines, use only mineral-proof rubber. Finally, do not operate the pump without fuel in the tank as it may shorten the pump life.

Note: The fuel flow should be 1.5 liters per 30 seconds, measured

at the carburetor connection.

3. Fuel filter.

Use care to install it for the correct flow direction.

4. Idle speed.

The idle speed should be set as low as possible to avoid back firing.

5. Fuel requirement.

The minimum octane requirement is 90. To provide sufficient lubrication for internal parts, the fuel must be mixed with the correct engine oil in a ratio, oil-to-fuel, of 1:100-1:150, measured by volume.

B. Lubrication system.

1. Engine oil.
A low ash content, mineral oil is recommended, with a viscosity of either 40 wt or 10w-40. The oil level should be $F \pm 5$ mm.
2. Oil cooler.
The oil cooler is easily clogged with debris thrown up from the track such as chunks of tire rubber or small stones. To maintain proper cooling performance, the core must be cleaned periodically.

C. Cooling system.

1. Like the oil cooler, the radiator core is easily clogged with debris such as chunks of tire rubber or small stones. To maintain cooling performance, it should be cleaned regularly.
2. Radiator hose and clamps.
There is no specific competition hose and clamp, but to avoid problems use high quality parts and maintain them in good condition.
3. Coolant.
We do not recommend using anti-freeze. For racing engines, we have found clean water to be the most suitable coolant.
The coolant should be changed regularly and drained in the winter to avoid freezing.
4. V-belt tension.
The V-belt tension should be adjusted for a deflection of 9-11 mm, measured equi-distant between the water pump and alternator.

D. Electrical system.

1. Distributor.
The distributor lead may be connected to either terminal on the ignitor. There is no advance mechanism with this distributor.
2. Ignitor.
The ignitor should be mounted in an area protected from heat, water and vibration. All wiring connections should be secure, and all wiring must be separated from high voltage wires by at least 100 mm.

3. High tension wires.
Pay particular attention to the connections and terminals on the high tension wires.
4. Spark plugs.
The recommended spark plug is NGK V-type, 11.5 heat range.
Note: The correct spark plug gap is 0.7 ± 0.1 mm.

Ignition Wiring

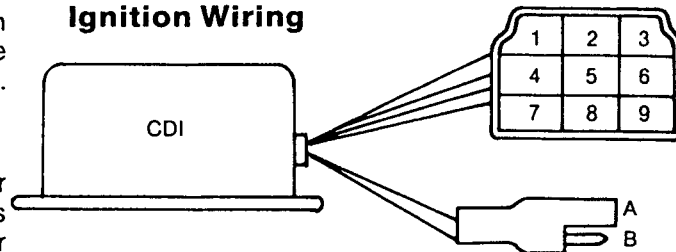

Connector number	Wire color	Tracer
1	black/white	Ignition switch
2	black/yellow	Starter solenoid terminal
3	black/red	Ignition coil positive terminal
4	black	Grounded
5	blue	Not used
6	yellow	Not used
7	yellow/green	Not used
8	red/white	Not used
9	white	Not used
A		Distributor signaling
B		Distributor signaling

5. Ignition timing.
The timing is set with the drive pulley notch and the indicator pin on the front cover; the notches are denoted as shown in the illustration below:

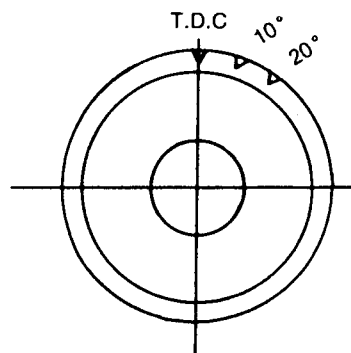

The trailing and leading plugs should both be set to fire at 20° BTDC.

VII. Operating Procedures.

A. Due to the high noise of the rotary engine, we recommend using a muffler around the garage or pit area.

B. An air cleaner is an absolute necessity at all times to avoid loss of compression from dirt entering the engine.

C. Starting and warming up the engine.
Before starting the engine, always check the engine oil and coolant and the V-belt tension. And look for any loose parts or fasteners.

1. Starting procedure.

Depress the throttle pedal a couple of times to squirt some fuel into the intake, then crank the engine while holding the throttle about two-thirds down.

Note: On cold days, circulate the engine oil for a short time before starting.

2. Warm-up procedure.

(1) First remove the radiator cap, then start the engine. Immediately after starting, check the oil pressure and release all air bubbles by both squeezing the water hose by hand and racing the engine a couple of times, then re-tighten the cap securely.

(2) The engine should be warmed at an idle speed of 2000-2500 RPM, until the oil temperature reaches 70° C or 160° F.

(3) During warm-up, watch for coolant and oil leaks, and be careful not to foul a spark plug.

D. Driving practices.

1. The maximum allowable engine speed is 9000 RPM.

2. Temperature and pressure recommendations are as follows:

	Normal	Limit
Coolant temperature (outlet side)	70-90° C (160-195° F)	95° C (205° F)
Oil temperature (oil pan)	90-110° C (195-230° F)	120° C (250° F)
Oil pressure (filter inlet)	5.5-7.5 kg/cm ²	5.0 kg/cm ²

When the oil or coolant temperatures exceed the limits, watch carefully and check the system to determine the cause. If the oil pressure falls below the lower limit, stop the engine immediately and determine the cause before proceeding.

E. Engine treatment after being run.

1. Pour a small amount of engine oil through the carburetor to prevent internal rust.

2. During the winter, drain the coolant completely.

F. Overhaul schedule.

Starting with a fresh engine, the overhaul schedules are based on engine rev limits used during racing, as follows:

With a rev limit of:	Rebuild after:
9000 RPM	2000-3000 km. (1300-1900 mi.)
8500 RPM	4000 km. (2500 mi.)

G. Compression check procedure.

Use the rotary engine compression tester, part number 49 0820 280K. A normal compression tester will not give a reading on the condition of each individual working chamber.

1. Prior to measurement:

- (1) Warm up the engine.
- (2) Remove the trailing spark plug.
- (3) Screw the compression tester fitting into the spark plug hole.
- (4) Disconnect the ignition at the ignitor.

2. Measurement procedure.

- (1) The compression tester operates on 12 volts.
- (2) To properly warm up the tracing needle the compression tester must be turned on five (5) seconds prior to operation.
- (3) Crank the engine with the throttle wide open for 10 seconds.
- (4) Turn off the power to the compression tester.
- (5) Record the compression readings.

CHASSIS/DRIVELINE

I. Explanation and Description of Competition Parts.

A. Clutch components.

1. Clutch cover, 4352 16 410
To eliminate clutch slippage, this clutch has a boss-type drive instead of the straight-type drive, and the working pressure has been increased from 380 kg to 630 kg. Additionally, it has a chrome-plated release collar bearing.
2. Clutch disc, 4352 16 460
This clutch has a solid center section without any shock absorbing springs. The friction material is V-782-J, specially selected for fade resistance, and the boss spline is chrome plated.
3. Clutch master cylinder.
This is the same as the stock part, but due to the size of the vacuum assist diaphragm for the brakes, the clutch master cylinder must be relocated for clearance.
4. Clutch release cylinder, 4352 41 920
This is an adjustable release cylinder with a piston diameter of 11/16".

B. Transmission.

These are the gear ratios of the stock five-speed transmission compared to the competition version:

	1st	2nd	3rd	4th	5th	Rev.
Competition	2.350	1.608	1.240	1.000	0.881 0.839	2.26
Stock	3.674	2.217	1.432	1.000	0.825	3.54

Competition trans:
4352-03-000 (0.839)
8570-03-000 (0.881)

1. Transmission case, 4352 17 100A
This case is cast aluminum with sections 1.4 mm thicker than stock (up from 4.6 mm to 6.0 mm), for increased strength, and it has a starter motor bracket to support the starter on both the front and rear ends.
2. Extension housing, 4352 17 331
As with the transmission case, the extension housing is also thicker through the sections. The speedometer gear and back-up lamp provisions have been elim-

inated, and the end bearing is a needle roller instead of the stock brushing.

3. Transmission mount, 4352-39-340
Compared to the stock version, this mount is made of harder rubber.
4. Main drive gear, 4352 17 201
The competition main drive gear has a chrome plated spline for increased wear resistance.
5. Synchronizer ring, 4352 17 245
To increase rigidity, the synchro cone diameter has been changed for 1st, 2nd, 3rd and 4th gears, from the 63 mm of the stock version to 62 mm, as shown in the illustration.

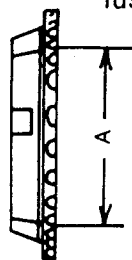

Cone diameter	(dimension A)
Competition	62 mm
Stock	63 mm

6. Synchronizer key and key spring, key: 4352 17 243
spring: 4352 17 244
The increased working preload of these parts improves the synchro action. These parts are applicable to 1st-2nd and 3rd-4th gears only. For 5th-reverse, the key and spring are the same as stock. The key dimensions are given in the illustration below:

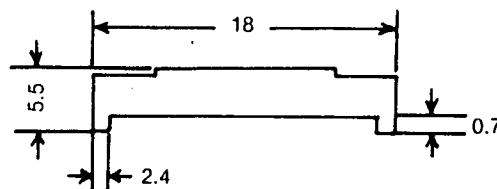

Groove depth
Comp. parts: 0.7 mm
Stock parts: 1.5 mm

7. Gear bearings.
Needle roller bearings are used on 1st, 2nd, 3rd and 5th gears.
8. Shifting forks,
1st-2nd: 4352 17 402
3rd-4th: 4352 17 404
5th-Rev: 4352 17 406

The 1st-2nd and 3rd-4th shifting forks are heavier and heat treated for strength and improved shifting action. The 5th-reverse fork is heat treated only.

9. Shift lever assembly, 4352 17 510
This is a one- instead of a two-piece lever, with a larger diameter than the standard version.

C. Driveshaft.

1. Driveshaft assembly, 4352 25 100
This is a special two-piece driveshaft with a center universal joint and support bearing. It has been designed to move the resonant frequency out of the working range of driveshaft speed. Its specifications and configuration are shown in the illustration.

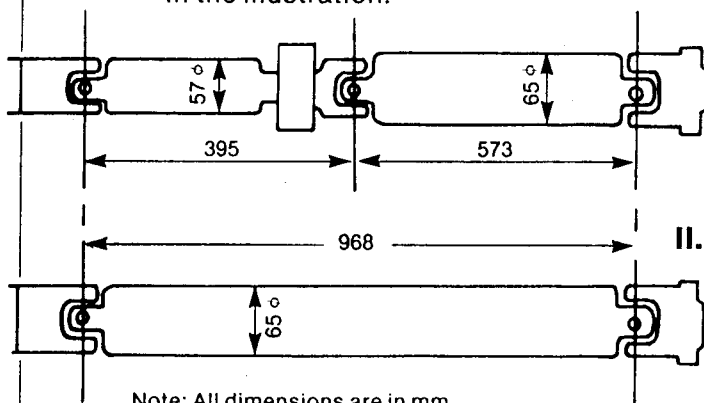

D. Differential.

1. Differential gears are available in the following ratios:

Ratio	Teeth (ring/pinion)	Part Number
4.111	37/9	1013-27-110
4.375	35/8	0839-79-950
4.444	40/9	1393-27-110A
4.625	37/8	0881-79-720
4.875	39/8	1312-27-110A

2. Limited slip differential, 0820 79 960B
The limited slip is a friction clutch type for simplicity and efficiency.
3. Differential carrier assembly, 4352 27 150
This carrier assembly is designed exclusively to work with the increased load capacity bearing also available as a competition part.
4. Rear bearing, 0540 27 141

This higher capacity bearing will accept the increased drive and torque loads of competition, but must be used with the differential carrier assembly mentioned above.

E. Rear axle.

1. Axle housing assembly, 4352 26 020

This axle housing has been designed to work with the factory rear disc brakes, and has a baffle plate to retain oil around the gears when cornering.

2. Axle shaft assembly, 4352 26 110

This axle shaft is designed to be used with the rear disc brake arrangement, and it includes a larger capacity bearing. It is fully compatible with the competition limited slip unit, but if used with the limited slip which is available to fit the stock version of the axle housing, the axle must be cut off by 5 mm on the splined end to avoid interference.

II. Notes on Machining and Assembly.

A. Clutch.

1. A stop block to limit clutch pedal travel must be fabricated and installed on the floorboard as shown in the illustration. Without the stop block, excessive clutch pedal travel will push the clutch diaphragm spring over center, resulting in the clutch hanging up and not re-engaging with high speed gear changes. Additionally, this excessive pedal travel will cause distortion of the diaphragm spring.

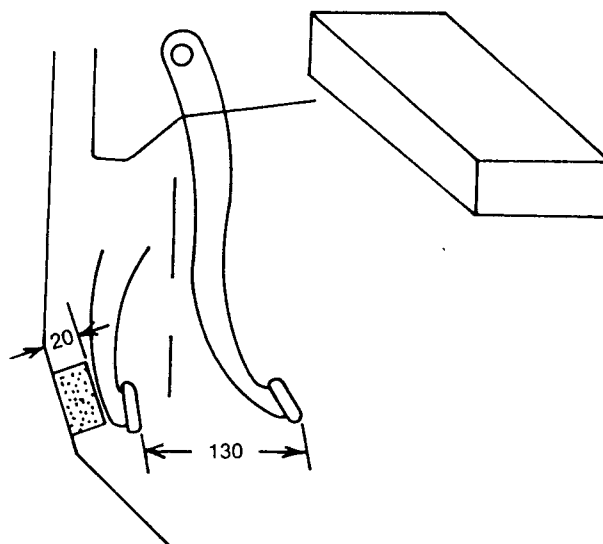

2. The illustration depicts lubrication points in the clutch mechanism assembly.

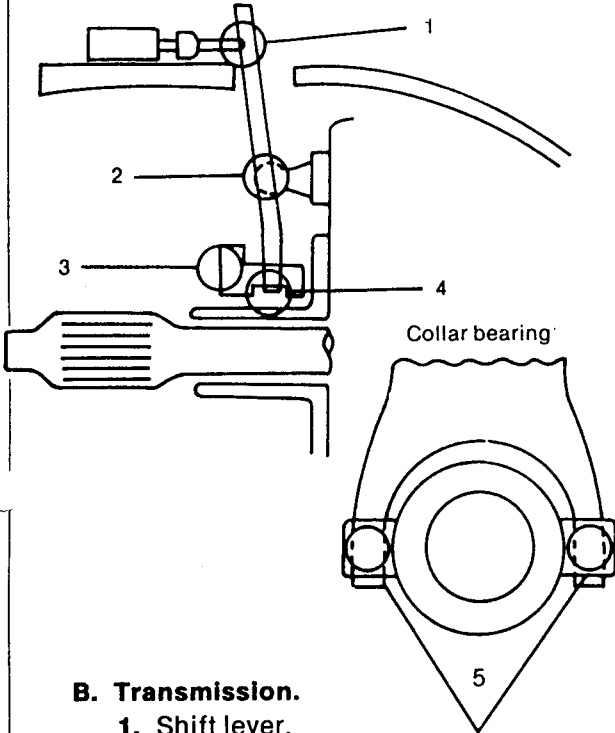

B. Transmission.

1. Shift lever.

The shift lever can be heated and bent to suit the driver's preference. Generally, we have found it should be inclined toward the driver by about 20° as shown in the illustration.

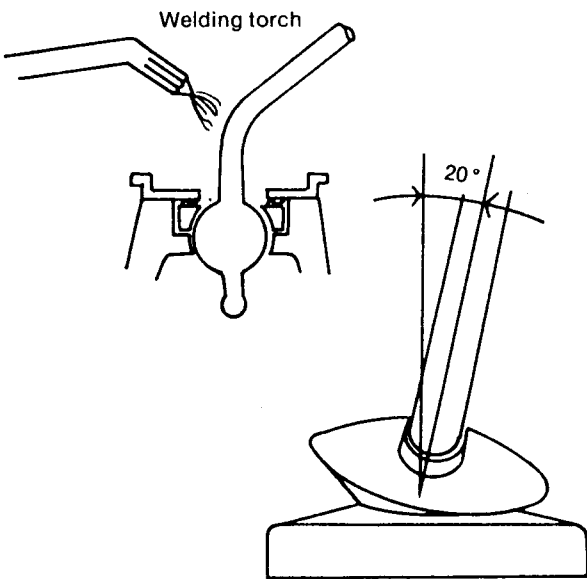

2. The rubber shift lever boot should be tied tight around the lever with wire to prevent oil leakage into the cockpit, as shown in the illustration.

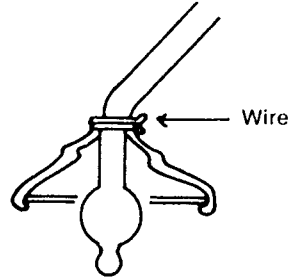

3. The end of the synchronizer key spring should be ground off so as to eliminate any chance of contact with the clutch hub, as shown in the illustration.

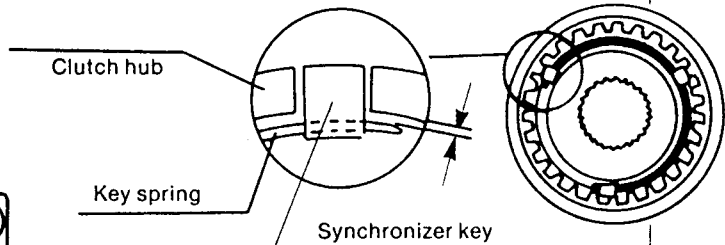

4. The shifting fork bolts should be secured with both Loctite and safety wire to thoroughly prevent any chance of loosening, as shown in the illustration.

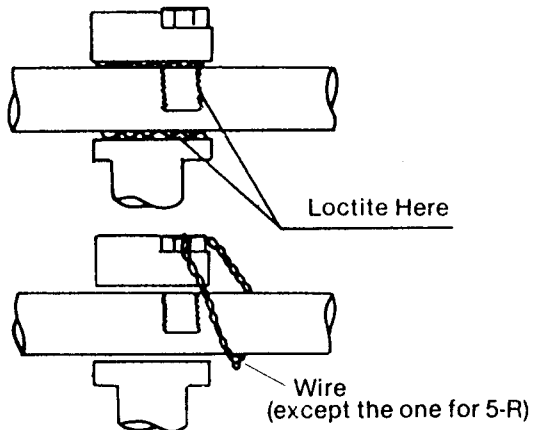

5. The configurations for the bushings for 1st, 5th and reverse gears are shown below. Use care to assemble them properly, with the correct gears.

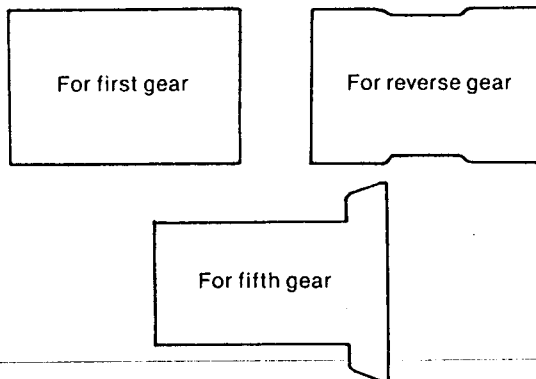

CHASSIS/DRIVELINE

6. The rubber transmission mounting block must be assembled in the direction shown in the illustration.

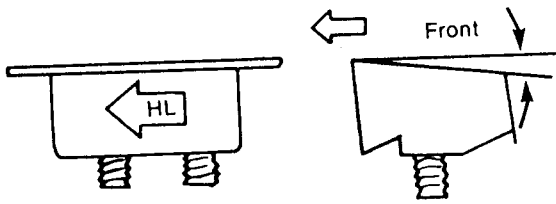

C. Differential.

1. The threaded portion of the breather is too long, so to prevent interference it must either be assembled with a 6 mm spacer nut, as shown, or cut by 5 mm.

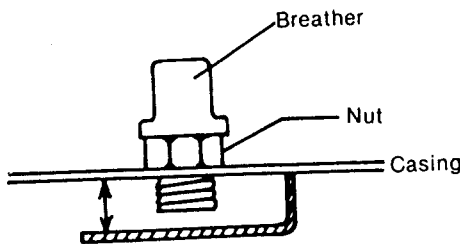

D. Driveshaft.

1. Center bearing support brackets.

(1) The following procedure is for the left side bracket.

- a) Fabricate the left bracket for the center bearing support according to the illustration. The material is steel plate, 1.4 mm thick, and the bolt is M10, P 1.25.

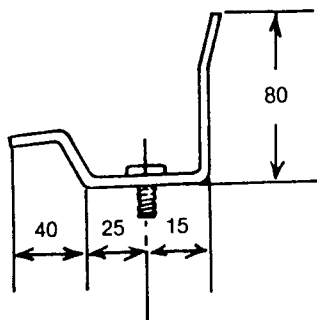
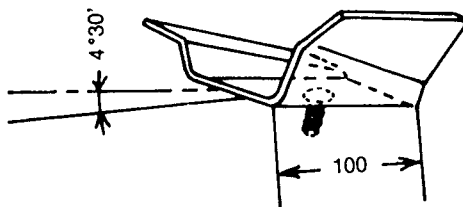

- b) The bracket should be welded to the underside of the floor pan as shown in the illustration below.

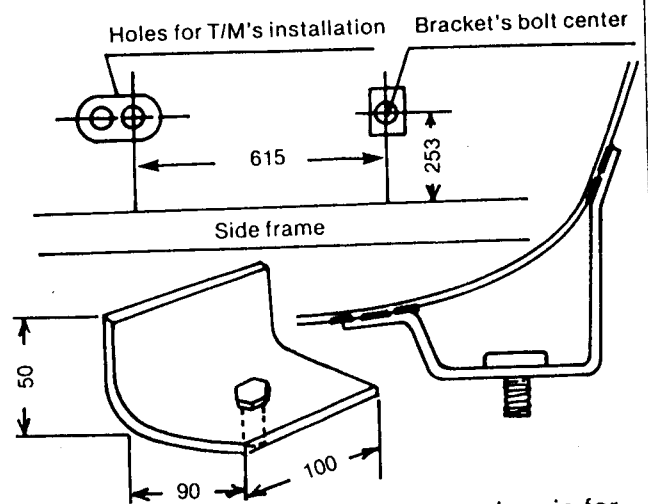

- (2) The following procedure is for the right side bracket.

- a) Fabricate the right bracket for the center bearing support as shown in the illustration. The material is steel plate, 1.4 mm thick, and the bolt is M10 P 1.25.

- b) Weld the bracket to the underside of the floor pan according to these instructions and the illustration.

- * The engine, transmission and rear axle must be mounted, and the left side bearing support bracket must be welded in place.
- * Assemble the center bearing support to the driveshaft, and then mount the driveshaft to the car, attaching the bearing support to the left side bracket.
- * With everything bolted up in place, mark the location on the floor pan for the right side bracket bolt relief hole.
- * Cut a 30 mm diameter hole on this location. With the bracket in place, there will be a clearance around the bolt head, and so the hole should be exactly on center.
- * Weld the bracket to the floor pan.

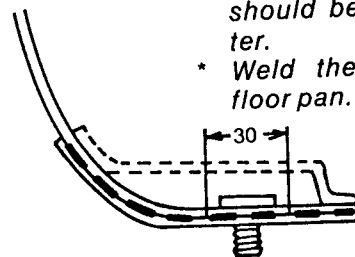

Note: After attaching the center support bearing, check and make certain the driveshaft is straight and true. It is recommended to check for driveshaft straightness before final welding on the brackets. One suggested method to check for straightness is to tie weighted strings to the transmission extension housing, center bearing and differential companion flange, then visually note the alignment from the rear; make certain all the strings hang from the exact centers of the three locations.

- The floor pan of the car must be pounded out as shown in the illustration for relief around the center bearing support.

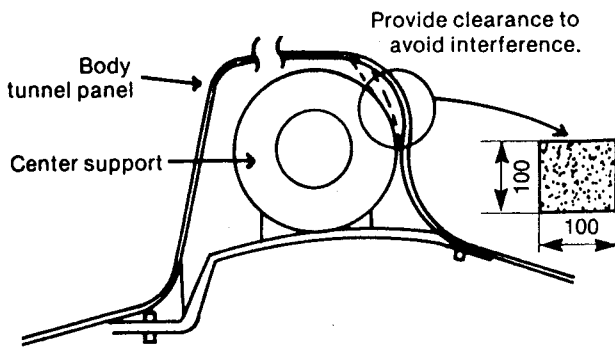

E. Rear axle.

- The rear axle should be mounted with the length of the lower control links set to 495 mm from center-to-center of the rod ends, so the nose of the differential is inclined upwards by 2°, as shown in the illustration.

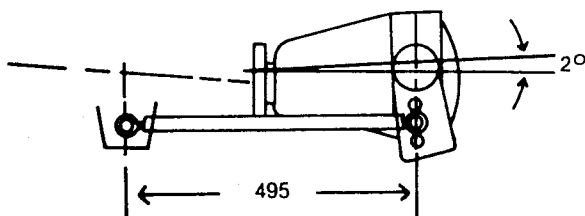

III. Checks, Adjustments and Practices.

A. Clutch.

- Pedal stroke.**
The pedal stroke should be set at 130 ± 5 mm, by adjusting the pedal stroke stop block and the pedal return stop.

- Free play.**
The free play settings are:
Between master cylinder and pushrod: 0.5 ± 0.25 mm.
Between release cylinder and pushrod: 1.5 ± 0.5 mm.
- When assembling the clutch disc, use either the transmission input shaft or a clutch alignment tool to align the disc properly.
- The clutch release fork return spring should be mounted inside a rubber tube to prevent the occurrence of resonant vibrations.

B. Transmission.

- Gear oil.**
Generally, 90 wt gear oil is recommended for most conditions. However, if the ambient temperature is over 85° F, a heavier lubricant should be used.
- Transmission break-in.**
While breaking in a new transmission, pay particular attention to any leaks, abnormal sounds or unusual vibrations. The break-in schedule is as shown in the table.

Engine rev limits	Mileage
6000	15
7000	15
8000	15
TOTAL	45

C. Driveshaft.

- The competition driveshaft has already been balanced as a complete assembly. If disassembling, use care to re-assemble it in the correct order to maintain its balance. Finally, the forward section should not be disassembled, as an unbalance on that end could lead to metal fatigue and cracking of the transmission extension housing.
- Make certain there is a balance weight on the driveshaft before using it.
- Check the universal joints according to the following directions and the illustration below.
 - The correct torque should be 3-8 kg-cm (with a new joint).
 - To check the forward universal joint, attach the sliding scale to the yoke.

CHASSIS/DRIVELINE

- (3) To check the rear universal joint, attach the sliding scale to the flange bolt hole.
- (4) To check the center universal joint, hang the driveshaft vertically from the forward end and attach the sliding scale with a wire around the drive-shaft, 100 mm from the center of the joint, as shown in the illustration.

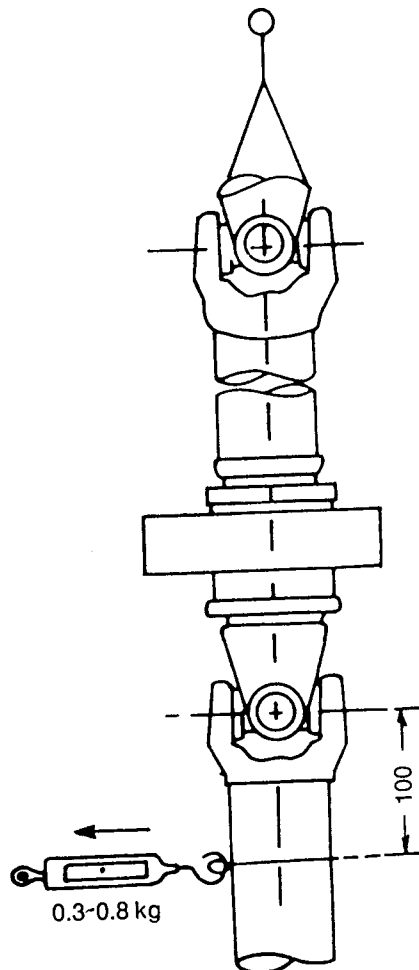
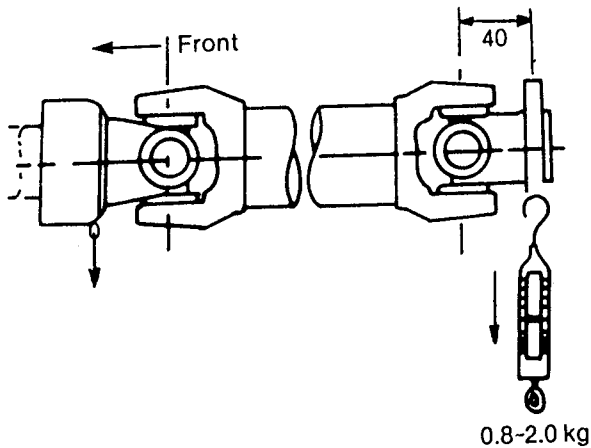

D. Differential.

1. Break-in.

A new differential must be broken in before using in competition. This can be done in a standard passenger car, and the procedure is as follows:

Operate at or below this speed:	For this number of kilometers:
60 km/h (40 mi/h)	100 km (60 mi)
80 km/h (50 mi/h)	100 km (60 mi)
100 km/h (60 mi/h)	200 km (120 mi)
Total:	400 km (240 mi)

Due to the initial preload on the pinion gear, lack of a proper break-in will result in an excessively high oil temperature and scoring of the gear teeth.

2. Lubricant.

The proper lubricant is 90 wt hypoid gear oil. The amount required for sufficient lubrication is 2.0 liters. When the ambient temperature is above 85 ° F, use a higher viscosity lubrication than the normally-recommended 90 wt.

3. Preload.

- (1) With a new pinion bearing the preload should be 9-14 kg-cm. After break-in, the proper preload is 2.3-3.5 kg-cm.
- (2) If using a used bearing, the preload should be the same as it was before disassembling the differential. If it is not possible to achieve that, replace the distance piece.

4. When exchanging the ring and pinion, use Loctite on the back of the ring gear and bolts. The tightening torque is 6.5-7.5 kg-m.

5. Breather.

According to the layout of the particular race course, there are three positions for the rear axle breather, as shown in the illustration. For example:

- (1) On a course with predominantly left hand turns, use positions 1 and 2 and block off 3.
- (2) On a course with predominantly right hand turns, use positions 2 and 3 and block off 1.

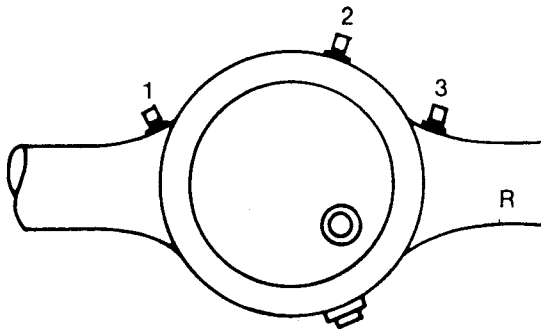

E. Rear axle.

Check the axle bearing and the bearing collar. If the clearance between the bearing and the collar is more than 1.0 mm, replace the axle shaft.

Check List For Driveline Components

1. Clutch.

ITEM	APPROPRIATE VALUE
Clutch pedal free play (until pushrod contacts piston)	1-3 mm
Clutch pedal free play (until release fork begins to move)	5-13 mm
Usable clutch disc thickness (depth at rivet hole)	0.3 mm
Reservoir fluid level	fill to max. level
Release fork free play (between fork and push rod)	1-2 mm

Tightening torques.

ITEM	TORQUE
Clutch cover	1.8-2.7 kg-m
Clutch housing	3.8-5.3 kg-m

2. Transmission.

ITEM	APPROPRIATE VALUE
Main shaft runout	0.03 mm
Clearance between synchronizer ring and gear	0.8 mm
Lubricant quantity required	2.0 liters
Lubricant type	SAE 90 wt. hypoid gear oil

Tightening torques.

ITEM	TORQUE
Main shaft lock nut	13.0-21.0 kg-m
Countershaft lock nut	12.0-16.0 kg-m
Shifting fork (1-2, 3-4)	1.2-1.7 kg-m
Shifting fork (5-R)	1.2-1.6 kg-m
Case	1.2-1.4 kg-m
Lock ball cap	1.0-1.5 kg-m

CHASSIS/DRIVELINE

3. Driveshaft.

ITEM	APPROPRIATE VALUE
Driveshaft runout	less than 0.4 mm
Universal joint resistance to movement torque	3-8 kg-cm

Tightening torques

ITEM	TORQUE
Companion flange	3.5-3.8 kg-m
Center support	3.7-5.5 kg-m

4. Differential.

ITEM	APPROPRIATE VALUE
Pinion bearing preload (new)	9-14 kg-cm
Side bearing preload (new)	6-21 kg-cm
Bearing cap pilot measurement	+ 0 185.5 - 0.075 mm
Ring and pinion backlash	0.17-0.19 mm
Backlash, maximum allowable variation	0.07 mm
Lubricant quantity required	2.0 liters
Recommended lubricant, viscosity & type	SAE 90 wt. hypoid
Ring gear runout	0.05 mm
Spacer (for adjusting pinion gear position)	14 spacer shims are available, in increments of 0.03 mm, from 3.08-3.47 mm thick

Tightening torques.

ITEM	TORQUE
Drive pinion nut	13.0-18.0 kg-m
Ring gear (use Loctite on back of ring gear)	12T 6.5-7.5 kg-m 12T flange, 7.5-8.5 kg-m
Side bearing cap	3.8-5.3 kg-m

CHASSIS/BRAKE SYSTEM

Specifications

Category	Item	Comp. spec.	Stock spec.	
Foot brake	Pedal ratio	4.77	4.77	
control parts	Power assist diaphragm diameter	7.5"	6.0"	
	Master cylinder diameter	15/16" & 1"	13/16"	
Front brake	Type	ventilated disc	solid disc.	
	Rotor thickness	25mm	18mm	
	Caliper	type	opposed	floating
		cyl. dia.	2-1/8"	2.0"
	Effective radius	102 mm	90 mm	
	Friction pad	material	SS-100, SS-123	F-50
thickness		9.7	9.0	
Rear brake	Type	solid disc	drum	
	Rotor thickness	10mm	N/A	
	Cylinder diameter	1-3/8"	11/16"	
	Effective radius	93 mm	100 mm	
	Friction pad	material	SS-100, SS-123	J-6020-C
		thickness	9.0	4.0
	Proportioning valve line pressure range	30-100 kg/cm ²	—	

I. Explanation and Description of Competition Parts.

A. Foot brake control system.

Compared to the stock unit, the competition assembly has greater efficiency through a larger servo assist vacuum diaphragm and a larger master cylinder diameter.

1. Power assist, for right-hand drive: 4352 49 800
for left-hand drive: 4352 43 800

As a result of increasing the assist vacuum diaphragm from 6.0" to 7.5" in diameter, the clutch master cylinder must be moved 25 mm to the left.

2. Master cylinders,
1": 4352 49 400
15/16": 4352 43 400

Two master cylinders are available to suit individual preferences and driving styles.

3. Master cylinder bracket, 4352 43 160

This bracket is used to facilitate remounting the clutch master cyl-

inder due to the increased size of the power assist vacuum diaphragm.

B. Front brake.

1. Rotor, 4352 33 251

This rotor is 25 mm thick, compared to the stock thickness of 19 mm, and has a larger effective radius, 102 mm instead of 90 mm.

2. Wheel hub, 4352 33 061

This wheel hub has a larger bearing capacity and special rotor attachment bolts.

3. Caliper,
R: 4352 33 610
L: 4352 33 710

Compared to the stock unit, this caliper has opposed pistons, larger cylinders and is assembled to the steering knuckle by two bolts.

4. Air duct,
R: 4352 33 260
L: 4352 33 270

This duct provides cooling air for the brakes.

CHASSIS/BRAKE SYSTEM

5. Friction pad,
SS-100: 4352 33 625
SS-123: 4352 33 725
The SS-100 is a harder compound for endurance racing; the SS-123 is intended for sprint races.

C. Rear brakes.

1. Rotor, 4352 26 251
This is a solid rotor, with an outer diameter of 254 mm (10 in), and is 10 mm thick.
2. Caliper,
R: 4352 26 980
L: 4352 26 990
These are sliding pin type calipers and include provision for a parking brake. They attach to the axle housing with a mounting adaptor, and the cylinder diameter is 1-3/8".
3. Mounting adaptor,
R: 4352 26 921
L: 4352 26 931
These adaptors are required to mount the rear brake assemblies to the axle housing.
4. Rear dust plate,
R: 4352 26 260
L: 4352 26 270
5. Friction pad, SS-100;
inner: 4352 49 625
outer: 4352 49 725
SS-123;
inner: 4352 26 625
outer: 4352 26 725
As with the front pads, the SS-100 is for endurance races; the SS-123 is for sprint races.
6. Variable proportioning valve,
3863 43 900

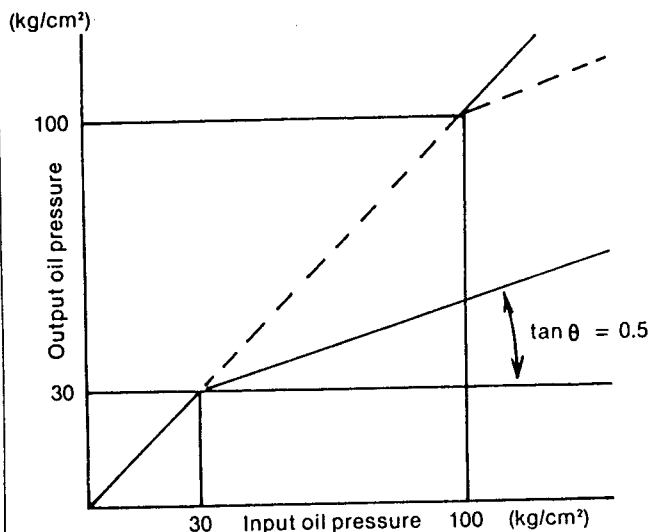

This valve will limit the line pressure to the rear brakes. The variable range is 30-100 kg/cm². With each clockwise turn of the adjustment, the line pressure will increase by 10 kg/cm².

7. Variable proportioning valve holder, 8871 43 750
Use the strut tightening nut to attach this holder to the structure of the car.

II. Machining Operations.

A. Changing the position of the clutch master cylinder.

Due to the larger power assist vacuum diaphragm, the clutch master cylinder must be moved to the left.

1. The procedure for moving the clutch master cylinder is as follows:
 - (1) As shown in the illustration below, locate and mark the new mounting holes on the firewall, 25 mm to the left of the standard ones.
 - (2) Block off the original holes with a suitable steel plate.
 - (3) Cut and drill the new holes.
 - (4) After completing the installation, cover and seal any holes that would allow water into the interior of the car.

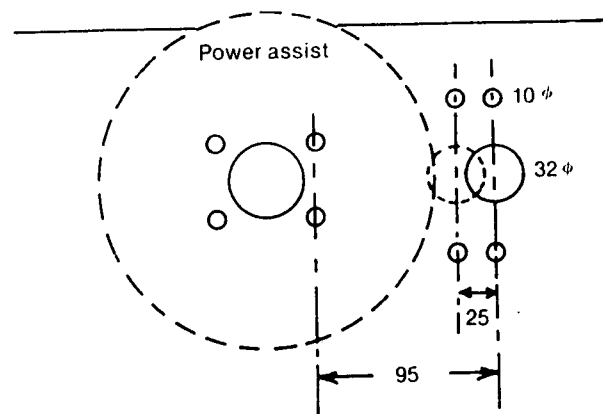

2. Modification to clutch pedal pushrod.

With the change of the master cylinder's location in the preceding operation, the pushrod's position will have to be changed as shown in the illustration.

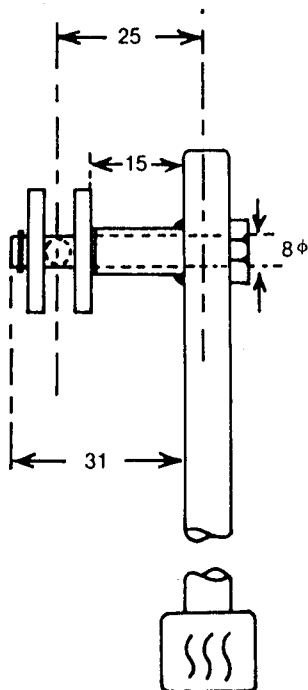

III. Checks, Adjustments and Maintenance.

A. Brake control parts.

1. Adjust the stroke at the brake pedal with a power assist valve operating rod, by turning this rod until the valve plunger has 5-7 mm of travel left before contacting the valve plunger stopper.
2. The effective stroke at the brake pedal should be more than 143 mm. If less than that, the brakes will not retract adequately and they could fade from the constant heat.
3. The brakes should be bled before each race, even if the system has been recently overhauled.
4. Do not mix brake fluids, and use only fluids with a high boiling point.
5. Avoid any water in the system. Even 2-3 percent water in the fluid will lower the boiling point sufficiently to cause a significant drop in efficiency. Additionally, it is strongly recommended to change the fluid before each race meeting.
6. Two master cylinders are available as competition parts; the 15/16" diameter version is standard. For a harder pedal feel or shorter stroke, the 1.0" cylinder is an alternative.

B. Front brakes.

1. Under normal racing use the competition rotors will last for about 3,500 miles. The rotors should be kept free of rust or any of the black corrosion which reduces friction between the rotor and the pads.
2. Whenever replacing the rotor, also replace the bolts which secure it to the hub.
3. Under normal racing use the wheel bearings should last for about 3,500 miles. Use molybdenum disulfide grease, and change it before every race.
4. The competition calipers are considered to be a semi-permanent item with an indefinite lifespan. However, they must be replaced if overheating has deteriorated their piston seals, resulting in improper or incomplete retraction of the pistons into the caliper.
5. Shims are used to achieve the required equalized clearance, side-to-side, between the rotor and the caliper. These shims fit between the caliper and knuckle, and are available in three thicknesses: 0.2, 0.6 and 0.8 mm. The shims can be used singly or in combinations to obtain a clearance on each side, measured between the rotor and the pads, or 1.5-2.2 mm.

The part numbers are:

0.2 mm	0813 33 617
0.6mm	0813 33 618
0.8 mm	0813 33 619

6. Whenever removing the hub from the knuckle, replace the hub caps to prevent damage to the wheel bearing that could result from the cap coming off.
7. The competition brake pad can be used until it is down to 1 mm thickness. Generally, these are the racing mileages to be expected from the pads:

SS-100	more than 1,000 km (600 mi)
SS-123	less than 1,000 km (600 mi)
8. It is always highly recommended to break in new pads for a few laps before a race.

CHASSIS/BRAKE SYSTEM

C. Rear brakes.

1. The competition brake rotor can be used until it is worn down to 9.0 mm thick.
2. The brake caliper includes an internal parking brake. There is a notch on the piston which should be matched exactly to the friction pad. The parking brake cable is positioned close to the rotor, so take care to route or support it to avoid contact and possible damage.
3. The recommendations for service and life of the front brake pads also apply to the rear pads.
4. The variable proportioning valve can be adjusted to suit individual preferences. However, as a starting point, use the following recommendations:

Dry conditions	80 kg/cm ²
Wet conditions	50-60 kg/cm ²

D. Plumbing and lines.

1. The tightening torque on the pipe nuts is 1.3-2.2 kg-m.
2. For protection, it is recommended the brake hose be wound with coils, but be careful not to damage the brake line with the wire.

Make certain the brake lines are the correct length; too short could cause breakage and ultimate failure of the system, too long loses efficiency, causes a softer feeling in the pedal, and could also result in the line rubbing against some rotating part or wearing against a rough edge.

Check List for Brake System

Item	Specification
Brake pedal free play	5-7 mm
Front rotor	254 mm (10 in) dia. x 25 mm thick
Friction pad thickness	9.7 mm (effective amount 8.7 mm)
Rear rotor	254 mm (10 in) dia. x 10 mm thick
Friction pad thickness	9.0 mm (effective amount 8.0 mm)
Amount of brake fluid	Fill to upper line

Tightening Torques

Item	Torque, kg-m
Front rotor and hub	1.0-1.3
Front caliper	8-10
Rear rotor	6.8-8.3
Rear caliper	4-4.8
Mounting adaptor	4-4.8
Brake lines	1.3-2.2

CHASSIS/STEERING AND SUSPENSION

CHASSIS/STEERING AND SUSPENSION Specifications

Category	Item	Comp. spec.	Stock spec.	Remarks
Steering	Steering wheel	same as stock		380 mm dia.
	Steering gear	14.5:1	17-20:1	
	Linkage	same as stock		
Front suspension	Coil spring rate	3.4 kg/mm	1.9 kg/mm	free length, comp: 252 mm stock: 338 mm
	Anti-roll bar	25 mm dia.	23 mm dia.	comp. location: 1 = 2.92; 2 = 2.79; 3 = 2.65; 4 = 2.53
	Shock absorber	adjustable piston rod, 22 mm dia.	non-adjust. piston rod, 20 mm dia.	max. length/travel, comp: 540/145 stock: 596/177
	Bump stop	30 mm ht.	40 mm ht.	
	Knuckle arm	reinforced		
Rear suspension	Coil spring rate	3.2 kg/mm	2.0 kg/mm	free length, comp: 278; stock: 315
	Shock absorber	adjustable	non-adjustable	max. length/travel, comp: 522/168 stock: 548/190
	Anti-roll bar	19 mm dia. 1.5 kg/mm	18 mm dia. 1.2 kg/mm	
	Bump stop	37.5 mm ht.	52.5 mm ht.	

I. Description and Explanation of Competition Parts

A. Steering.

1. Steering gearbox.

for right-hand drive: 4352 86 030

for left-hand drive: 4352 32 920

This gearbox has a quicker ratio of 14.5:1.

B. Front suspension.

1. Coil spring, 4352 34 011

To lower the car, reduce roll when cornering and pitch when braking, this is a shorter, stiffer spring. The design details are as follows:

	Competition	Stock
Wire diameter (mm)	12	12
Free length (mm)	252	338
Spring rate (kg/mm)	3.4	1.9

2. Strut assembly,

R: 4352 34 910

L: 4352 34 920

(1) The dampening characteristics of these shocks have been selected for racing purposes.

(2) Compared to the stock unit, they have less travel.

(3) They are adjustable to allow for chassis tuning.

(4) The knuckle spindle is stronger for increased durability and safety.

3. Bump stops, 4352 34 111

To retain sufficient suspension travel with the lowered ride height of the shorter springs, the bump stops are shorter than stock by 10 mm.

4. Anti-roll bar, 4352 34 151

The details of this larger bar are as follows:

	Competition	Stock
Diameter (mm)	25	23
Rate (kg/mm)	2.75	2.0

Additionally, this bar has four positions for the connecting link, providing several combinations of stiffness and allowing ease of chassis tuning.

5. Lower arm assembly,

R: 4352 34 300

L: 4352 34 350

CHASSIS/STEERING AND SUSPENSION

Knuckle arm:
R: 4352 32 301
L: 4352 32 311

The linkage utilizes a spherical rod end instead of rubber bushings. And the knuckle arm is stronger and has been redesigned for clearance around the wheel and tire.

6. Tension rod, 4352 34 130
Bracket, R: 4352 34 850
L: 4352 34 860

To eliminate longitudinal compliance of the lower control arm the forward end of the tension rod has a spherical rod end joint.

7. Crossmember, 4352 34 800
This is the same configuration as stock, but is stronger.
8. Alignment settings for front suspension:

	Competition	Stock
Camber	-1° 30'	+1°
Caster	3°	4°
King pin inclination	14° 42'	10° 55'
Toe-in (mm)	O-out 0.5	3 ± 3
Camber offset (mm)	84.2	38
Caster trail (mm)	14	19

C. Rear suspension.

1. Coil spring, 4352 28 011

This spring is shorter and stiffer than stock; these are the design details:

	Competition	Stock
Wire diameter (mm)	middle, 11.2 both ends, 9.0	10.2
Free length (mm)	278	315
Spring rate (kg/mm)	3.2	2.0

2. Rear shock absorber, 4352 28 700
 - (1) The dampening characteristics have been selected for racing purposes.
 - (2) Compared to the stock unit, it has less travel.
 - (3) It is adjustable to allow chassis tuning.

3. Rear anti-roll bar, 4352 28 151
These are the design details:

	Competition	Stock
Diameter (mm)	19	18
Rate (kg/mm)	1.5	1.2

4. Rear axle control arms,
upper: 4352 28 300
lower: 4352 28 200

The lower arm has spherical rod ends instead of rubber bushings. The upper arm has rubber bushings to prevent interference when cornering and is longer than stock.

	Competition	Stock
Length of upper link (mm)	413	247
Length of lower link (mm)	495	500

5. Watt link assembly,
lateral arms: 4352 28 200
4352 28 400
center link: 4352 28 450

The connections are spherical rod ends instead of rubber bushings. To allow changing the roll center, the center link has two mounting positions.

Link length	Competition	Stock
Right (mm)	395	323
Left (mm)	500	430

6. Bump stop rubber, 4352 28 320
To retain suspension travel despite the lowered ride height, this bump rubber is shorter than the stock version.

II. Machining and Installation Operations.

A. Steering linkage.

1. Reinforcement of side frame rail (gear-box attachment point).
Fabricate a steel plate and weld to the side frame rail as shown in the illustration. This will increase the rigidity of the steering linkage.

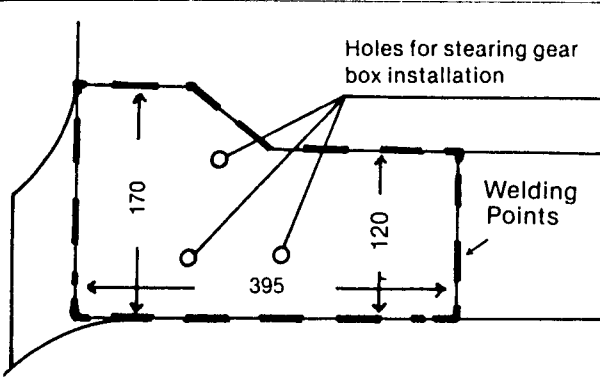

2. Steering post position.

Fabricate and install a spacer between the dash panel and steering post mounting bracket as shown in the illustration.

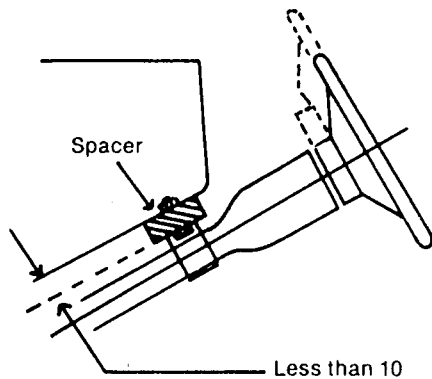

B. Front suspension.

1. Enlarge inside diameter of thrust bearing.

To accept the larger diameter of the competition shock absorber, the inside diameter of the thrust bearing must be enlarged from 20 to 22 mm as shown in the illustration.

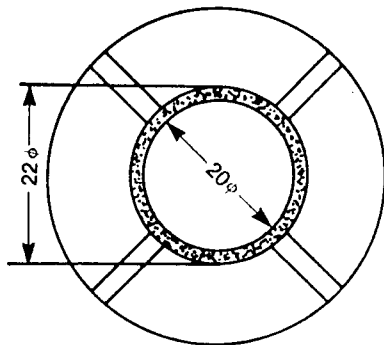

2. Mounting strut assembly.

When mounting the competition strut assembly, the position of the mark should be towards the outside rear as shown in the illustration.

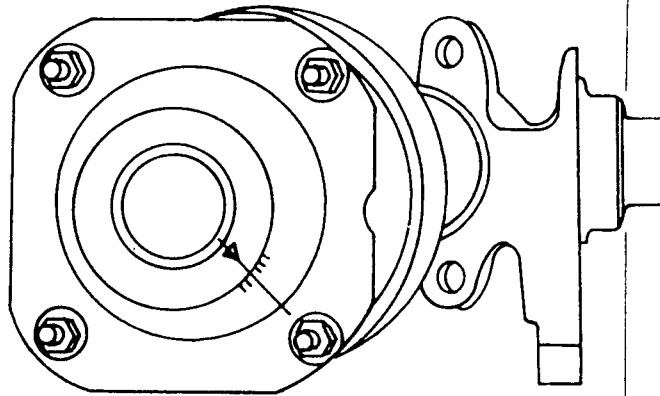

3. Removal of bump stop brackets on the lower control arm.

Since the knuckle arm contacts the bump stop bracket, 10 mm must be cut off the upper side, as shown in the illustration.

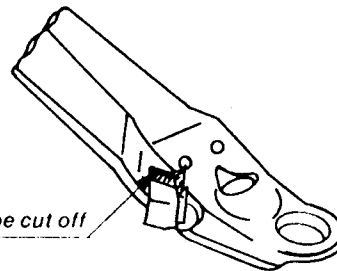

4. Installation of anti-roll bar.

The anti-roll bar should be mounted with the holes downward, as shown. There are four positions, but hole #2 is the standard setting and should be the starting point for chassis adjustment before trying any of the others.

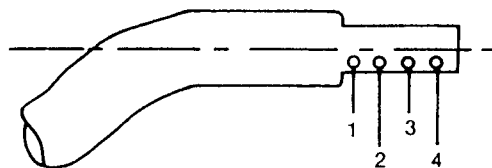

CHASSIS/STEERING AND SUSPENSION

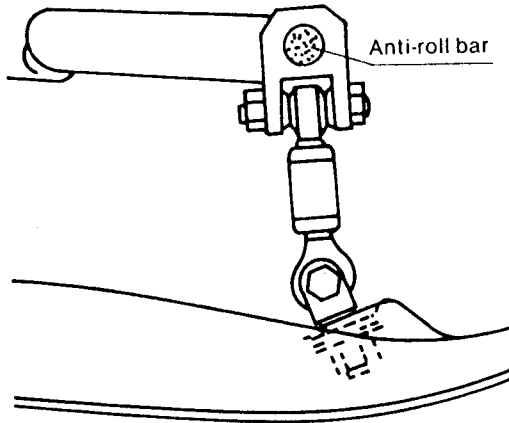

5. Tension rod.

Though there are two mounting holes, try the upper one first as it is the standard setting.

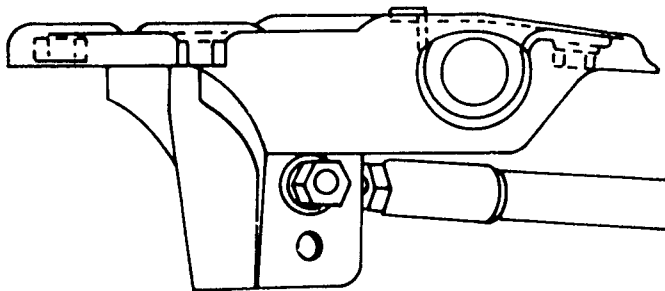

C. Rear suspension.

1. Lower link installation.

(1) Chassis pick-up points.

Fabricate 5 mm thick reinforcements and weld them in place as shown below.

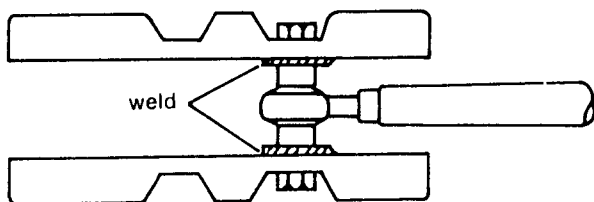

(2) Axle housing mounts.

The standard position is the #2 hole; try it first. The distance between spherical joints on a lower link is 495 mm.

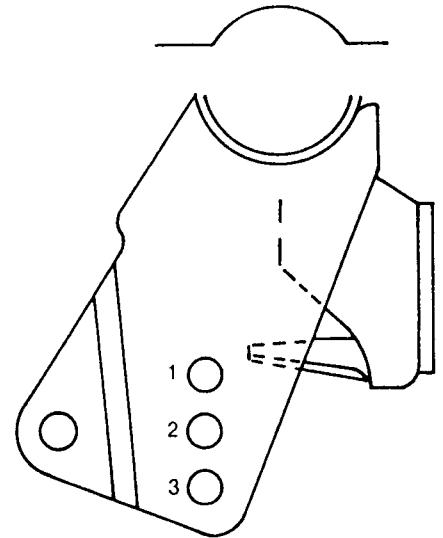

2. Upper link installation.

(1) Axle housing mounts.

In this case, hole #1 is the standard setting and should be tried first. The distance between spherical joints on the upper link is 413 mm.

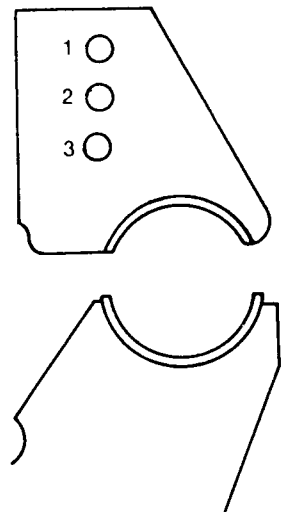

3. Fabricate and weld the brackets for the Watt link as shown below.

Bracket (Right)

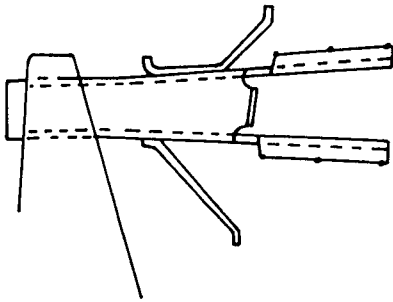

Bracket (Left)

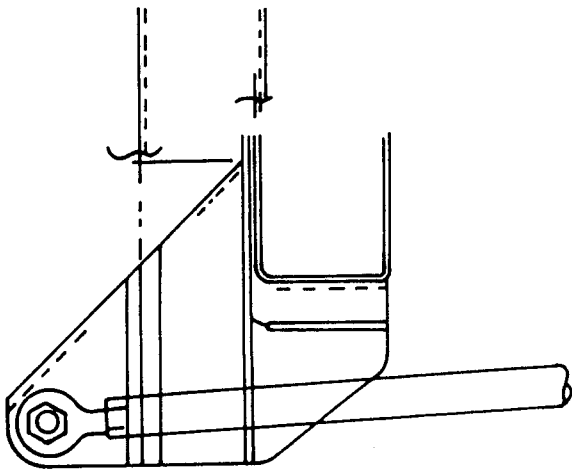
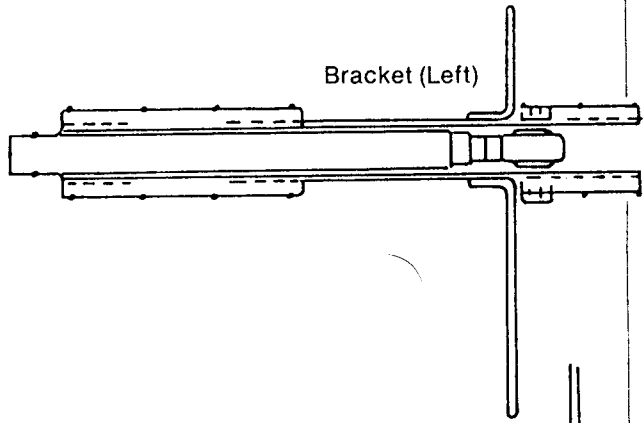

4. Mounting of center link.
There are two mounting positions, but #1 is the standard setting and should be tried first.

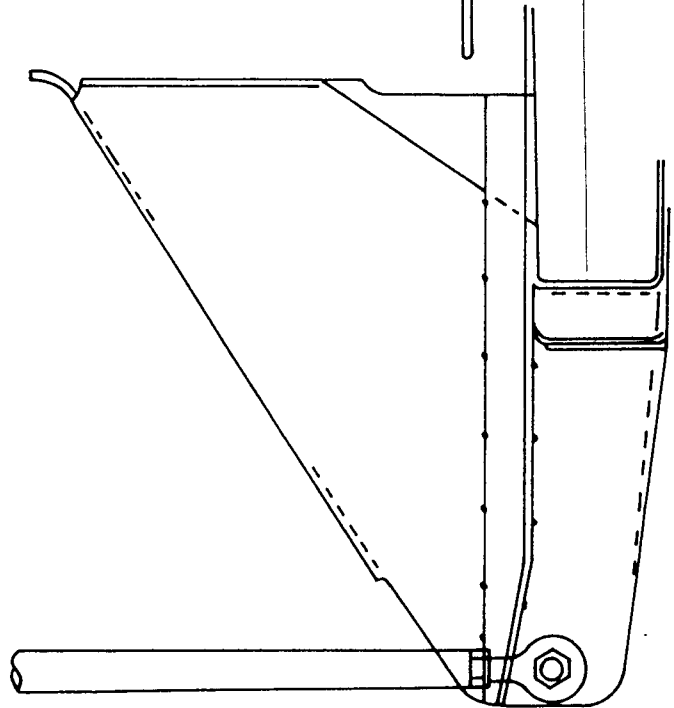
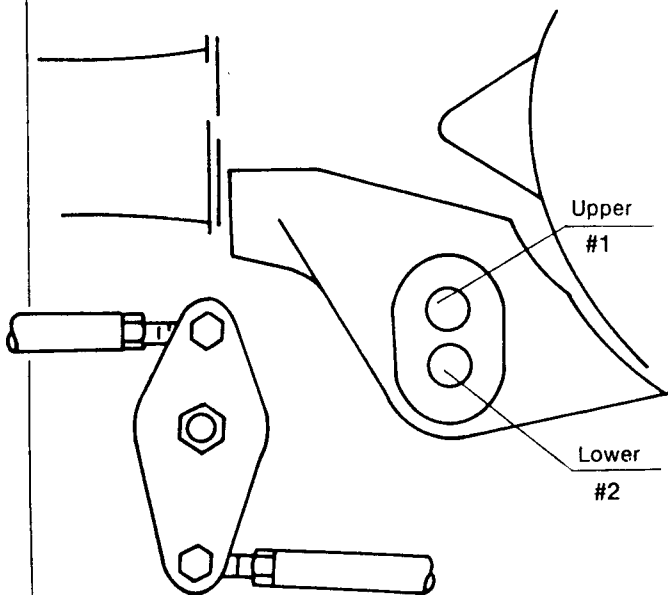

Scale: 1/4

5. Mounting of rear anti-roll bar.

The mounting location on the chassis is identical to the stock position. The correct center-to-center distance for the rod end connecting link is 100 mm.

CHASSIS/STEERING AND SUSPENSION

6. Mounting of front anti-roll bar.

As a result of the larger diameter of the bar, the side frame rails must be relieved by cutting as shown in the illustration.

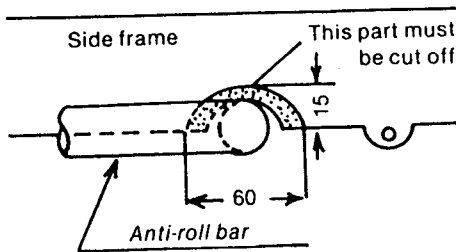

7. Side frame modification.

With the reinforced crossmember, the side frame rail flanges must be cut as shown. After cutting, it must be rewelded.

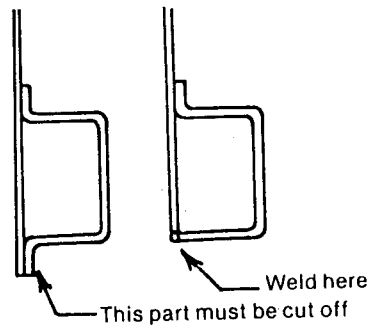
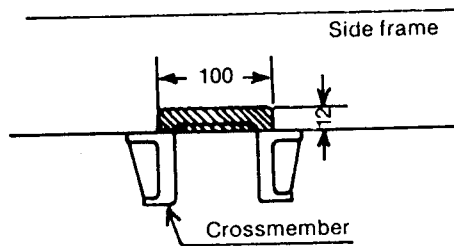

III. Checks, Adjustments and Maintenance.

A. Steering.

1. Steering gear.

- (1) The lubricant requirement is SAE 90 wt and the capacity is 170 cc.
- (2) The free play is 10-15 mm measured at the steering wheel rim.

- (3) Any noises from the internals of the gearbox indicate the complete steering gearbox should be replaced.

2. Center link, tie rod and knuckle arm.

When replacing these parts, exercise care not to damage the rubber bushings.

3. Maximum steering angle.

The maximum steering angle is $1\frac{1}{4}$ turn off center of the steering wheel in each direction. It should be adjusted by the stopper on the knuckle arm.

B. Suspension.

1. Rod end alignment.

- (1) All rod ends should be adjusted with the car on the ground, and proper alignment is shown below.

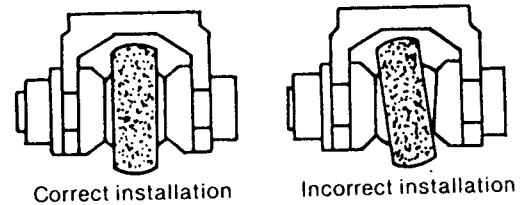

- (2) Note the correct position of the spacers as shown in the illustration.
- (3) Check the rod ends for wear or cracking on the threaded portion.

C. Front suspension.

1. Alignment.

- (1) The front end alignment can be adjusted with the rod end joints.

Note: When checking any chassis alignment, the car should be filled with 15 gallons of fuel and have a person in the driver's seat to simulate the racing weight.

(2) Camber.

The camber is adjustable within a range of -1.0° to -3.0° . One turn of the lower arm rod end joint alters the camber by approximately $7'$.

(3) Toe-in.

One turn of the tie rod will change the toe-in by approximately 5 mm.

2. Shock absorber.

The shock absorber has an eight-position adjustment; the higher the number, the more stiffness and control. The shock absorber should be adjusted to suit individual preferences.

(2) Checking the shock absorbers.

Set both right and left sides to the same position. Compare stiffness, both on bounce and rebound. Also, check for bent piston rods.

3. Front anti-roll bar.

There are four holes in the ends of the anti-roll bar to allow chassis tuning to suit preferences or course characteristics.

Spring rates (kg/mm)			
No. 1	No. 2	No. 3	No. 4
2.92	2.79	2.65	2.53

Hole #2 is the standard setting and should be used as the baseline for chassis adjustment and tuning.

4. Check the rod end joints throughout the front suspension for wear or cracking on the threaded portions.

5. Lubrication.

Molybdenum disulfide (MoS_2) is recommended for chassis lubrication on any appropriate joints.

D. Rear suspension.

1. Shock absorber.

- (1) Attaching the adjusting dial.
 - a) Turn the adjusting shaft counterclockwise all the way to the end of its travel.
 - b) On the adjusting dial, turn the pointer to position No. 1.

- c) Set the adjusting dial on the shock absorber and rotate it, stopping when it makes a click-like sound. Then lock the adjusting dial in place with the locknut.

These steps are shown in the illustration.

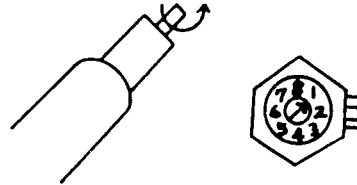

- (2) There are eight adjustments on the shock absorbers. The higher the number, the firmer the shock absorber will be. The shocks should be adjusted to suit individual preferences and characteristics of the course.

(3) Checking the shock absorbers.

Set both left and right sides to the same setting, then compare stiffness on both bounce and rebound. Finally, be sure there are no bent piston rods.

2. Upper link.

Tighten the upper link with the car on the ground for proper alignment and loading.

E. Break-in procedure.

1. New front hub bearings should be broken-in for at least 50 km (30 mi).
2. After initial break-in, check the preload on the hub bearing. It is important that it be 0.6-1.2 kg at the wheel clip bolt.
3. If the entire suspension has been rebuilt with new parts, the system must be broken-in for a total of 200 km (120 mi) as follows:
 - 100 km (60 mi) at 30 percent full load, then:
 - 100 km (60 mi) at 80 percent full load.
 After break-in, retighten the entire suspension system.

CHASSIS/STEERING AND SUSPENSION

Tightening Torques For Suspension Components

	Torque, kg-m
Steering	
Gearbox to frame rail	4.4-5.5
Pitman arm to sector shaft	13.0-17.0
Steering wheel to shaft	3.0-4.0
Tie rod spherical rod ends	3.0-4.5
Tie rod lock nuts	7.0-8.0
Idler arm to frame rail	4.4-5.5
Front suspension	
Shock absorber to knuckle arm	8.0-9.5
Shock absorber piston rod to mounting block	6.5-8.2
Lower arm to crossmember	7.6-9.5
Crossmember to side frame rail	3.8-4.7
Tension rod to frame mounting point	7.6-9.5
Tension rod to lower arm	5.5-6.9
Rear suspension	
Upper link attachment bolts, both ends	7.6-9.5
Lower link attachment bolts, both ends	7.6-9.5
Watt link attachment bolts, both ends	7.6-9.5

Note: Bolts should be tightened to the upper limit.

COMPARISON OF SPECIFICATIONS RX-7 and RX-3 (Engine and Driveline)

Engine

Basic performance specifications.

	RX-7	RX-3	Remark
Maximum power	270 PS at 9000 RPM	250 PS at 9000	
Maximum torque	23 kg-m at 8000 RPM	21 kg-m at 8000	
Maximum RPM	9000	←	

Basic mechanical specifications.

Displacement	573 × 2 (1146 cc)	←	
Layout	two rotors	←	
Compression ratio	9.4:1	←	
Intake system	peripheral port	←	
Exhaust system	peripheral port	←	
Carburetion	down draft Weber	←	
Lubrication	wet sump	←	
Cooling system	water circulation	←	
Ignition system	full transistor CDI	point distrib.	

Major parts specifications.

Rotor housing.

Trochoid spec.	R x a = 102 x 3	R x a = 101 x 4	due to apex seal
	improvement for cooling		
Intake timing	I.O./I.C. = 86°/75°	←	
Port shape	"D" Port	Round Port	
Exhaust timing	E.O./E.C. = 73°/65°	←	
Port shape	Elliptical Port	←	
Spark plug location and hole diameter	T/L = 30/18 T/L = 4.2/12	←	

Side housing.

Material/surface treatment	special cast iron/gas nitrogen	special cast iron	
Intake port	plugged	requires plugging	
Ventilation	0.5 liter oil separator tank	requires making separator tank	

Oil pan.

Configuration	large capacity with baffle plate	stock	baffle prevents loss of oil pressure
Gasket	2 pcs (both sides of baffle plate)	1 pc.	

APPENDIX

Tension bolts.			
	RX-7	RX-3	
Configuration	rubber bonded to center	stock	to remove resonant vibration
Front cover.			
	stock	←	
Stationary gear.			
Treatment	nitrogen	stock	
	has grooves to relieve stress	grooves must be machined	
Main bearing.			
	stock	←	
Oil clearance	50μ - 80μ	50μ - 70μ	
Rotor.			
Material/treatment	special cast iron/chrome-plated apex seal groove	←	
Combusion chamber	M.D.R. (Medium Deep Recess)	←	
Apex seal groove width	3 mm	6 mm	
Side seal groove	1	2	
Internal gear	held in place by snap ring	←	
Rotor bearing.			
	stock	←	oversize is available
Securing method	clinch lock and locking screw	clinch lock	
Oil clearance	70μ - 100μ	70μ - 90μ	
Eccentric shaft.			
Δ D	20μ - 30μ	stock	
Flywheel.			
	two-piece	one-piece	
Balance and counterweight.			
	combination	with flywheel	

Apex seal.

	RX-7	RX-3
Material/thickness	TMC-15T/3 mm	TMC-15T TR230/6mm
Configuration	one-piece without taper cut	one-piece with taper cut

Apex seal spring.

Load	1.5 kg	2.9 kg
------	--------	--------

Corner seal.

Groove for apex seal	3 mm	6 mm
Treatment	Molybdenum sprayed surface	←
Configuration	solid	←

Side seal.

	one-piece	two-piece
Material	molybdenum sprayed surface	stock

Side seal spring.

	stock	←
--	-------	---

Oil seal.

Material	stock ('79 model)	←
----------	-------------------	---

Oil seal spring.

Load	in. 15 kg (stock) out. 13 kg	in. 15 kg (stock) out. 8 kg (stock)
------	---------------------------------	--

Seal clearance.

Δ G	0.06-0.07	0.05-0.06
Δ S	0.09-0.11	0.09-0.12
Δ C	0.020-0.048	←
Δ E	0.05-0.15	←
Δ H	0.15-0.20	0.10-0.15
Δ R	0.13-0.17	←
Δ F	0.4-0.7	←

Intake manifold.

Total length	420	400
Manifold length	front 155, rear 165 (mm)	front 135, rear 145 (mm)
Mounting angle	4° 40'	5° 05'

APPENDIX

Lubrication system.

	RX-7	RX-3	
Pressure regulator	7.0 kg/cm ²	6.5 kg/cm ²	
Safety valve	11.0 kg/cm ²	←	

Oil pump.

	shaft: heat treat. rotor: gas nitrogen	←	
--	---	---	--

Water pump.

Material	aluminum	cast iron	
Pulley diameter	130 mm	←	

Ignition system.

Type	full transistor (CDI)	breaker point distributor	
Timing	20° BTDC (T/L)	15° BTDC (T/L)	
Advance mechanism	none	←	

Spark plug.

Type & gap	V-type 0.7 mm	EPD type 0.5 mm	
	Different drive ratio forged for strength		

High tension wires.

	wire core	carbon core	
--	-----------	-------------	--

Alternator.

Capacity	35 A	←	
----------	------	---	--

Starter.

Type	direct type	indirect type	more capacity for RX-7
Mounting	below bellhousing	above rearhousing	
Bracket	with	without	

Drive pulley.

Material	aluminum	cast iron	
Pulley diameter	90 mm	←	

Fuel pump.

Type	electronic, two required	←	
Output	2.0 liters per min	←	
Operation pressure	0.3 kg/cm ²	←	

Exhaust system.

	RX-7	RX-3	Remarks
Material	SUS304, 42 mm dia. x 1.5 mm thick	←	
Length	dual pipes: 230 cm collector: 100 cm	←	
Configuration	split type (F & R) sliding connection	one-piece	for performance
	sliding connector	bolted flange connector	for durability

Oil cooler.

Type/material	air/aluminum	←	
Dimensions	500 x 164 x 49	←	

Radiator.

Type/material	air/aluminum	←	
Dimensions	560 x 400 x 49	←	

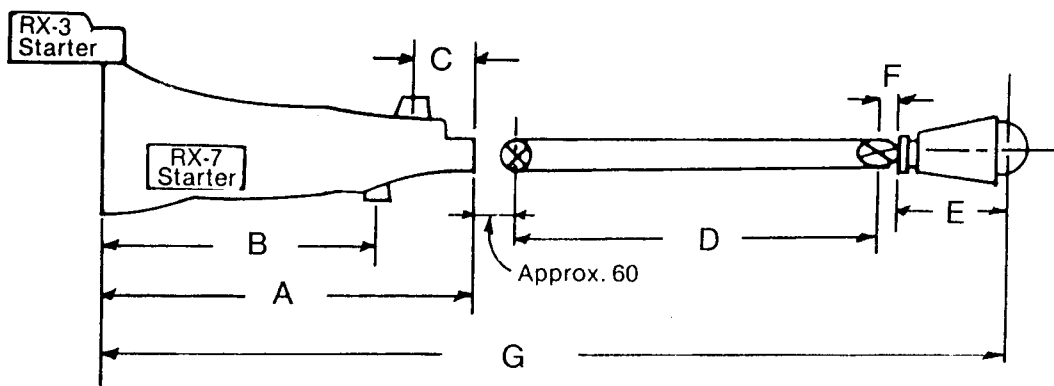

Spec.	A	B	C	D	E	F	G
RX-7 Comp.	806.0	546.0	112.0	968 (φ57) 2 pcs. (065)	243.0	40.0	2117
RX-3 Comp.	860.0	550.0	205.0	983 (φ75) 1 pc.	303.0	40.0	2246
RX-7 Stock	806.0	546.0	110.0	968 (φ65) 1 pc.	243.0	40.0	2117

All dimensions are given in millimeters.

APPENDIX

Transmission

RX-7 Comp.

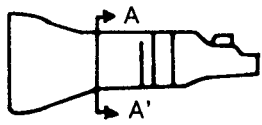

Weight: approx. 36 kg

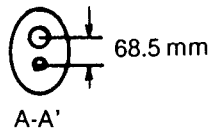

RX-3 Comp.

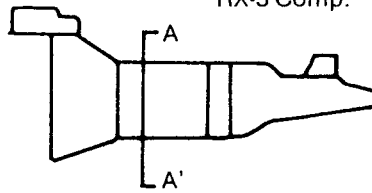

Weight: approx. 40 kg

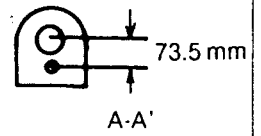

Differential

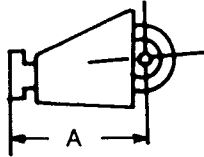

A: RX-7 243.0 mm
(comp. and stock)
RX-3 303.0 mm
(comp. and early model stock)

Differential carrier and rear bearing for RX-7 competition are heavy duty while RX-3 uses stock parts.

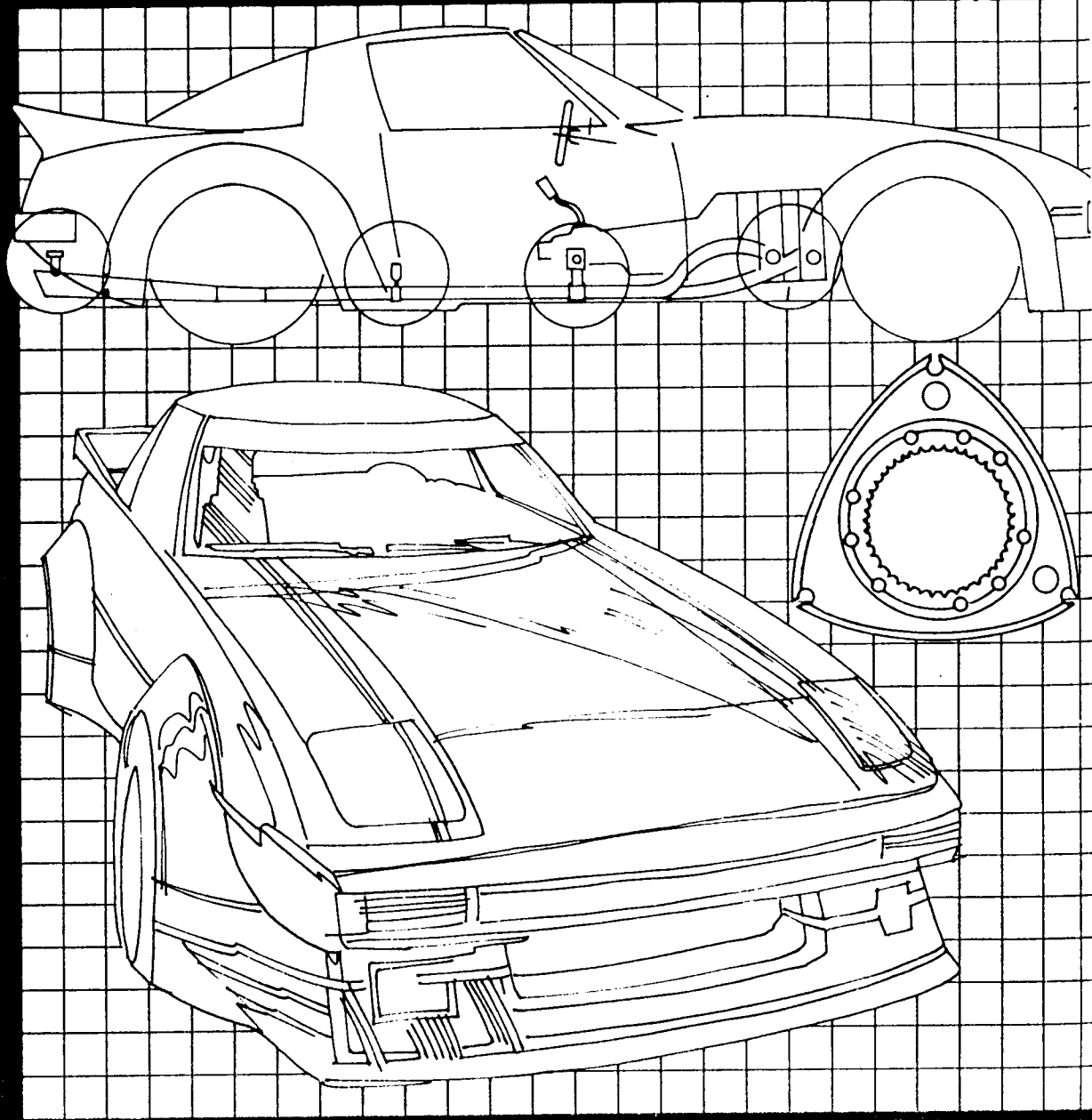

mazda